



Valued Quality. Delivered.

TEST REPORT

Report No.: 16031540HKG-001

Toy State International Limited

Application
For
Certification
(Original Grant)
(FCC ID: V9Q-94130R24)

Transceiver

Prepared and Checked by:

Approved by:

Signed On File
Leung Sung Tak, Andy
Assistant Engineer

Wong Kwok Yeung, Kenneth
Senior Lead Engineer
Date: May 20, 2016

- Intertek's standard Terms and Conditions can be obtained at our website <http://www.intertek.com/terms/>.
- The test report only allows to be revised within the retention period unless further standard or the requirement was noticed.
- This report is for the exclusive use of Intertek's Client and is provided pursuant to the agreement between Intertek and its Client. Intertek's responsibility and liability are limited to the terms and conditions of the agreement. Intertek assumes no liability to any party, other than to the Client in accordance with the agreement, for any loss, expense or damage occasioned by the use of this report. Only the Client is authorized to permit copying or distribution of this report and then only in its entirety. Any use of the Intertek name or one of its marks for the sale or advertisement of the tested material, product or service must first be approved in writing by Intertek. The observations and test results in this report are relevant only to the sample tested. This report by itself does not imply that the material, product, or service is or has ever been under an Intertek certification program.
- © 2016 Intertek

Intertek Testing Services Hong Kong Ltd.

2/F., Garment Centre, 576 Castle Peak Road, Kowloon, Hong Kong.

Tel: (852) 2173 8888 Fax: (852) 2785 5487 Website: www.hk.intertek-ettsemko.com

INTERTEK TESTING SERVICES

GENERAL INFORMATION

Grantee:	Toy State International Limited
Grantee Address:	Unit 905, 9/F., West Wing, Tsim Sha Tsui Centre, 66 Mody Road, Tsim Sha Tsui East, Kowloon, Hong Kong.
Contact Person:	Cheung Yiuchung
Tel:	0755-3680 6243
Fax:	0755-2870 0487
e-mail:	N/A
Manufacturer:	Toy State International Limited
Manufacturer Address:	Unit 905, 9/F., West Wing, Tsim Sha Tsui Centre, 66 Mody Road, Tsim Sha Tsui East, Kowloon, Hong Kong.
Brand Name:	Nikko
Model:	94131
Additional Model:	94411, 94386, 96005, 94133, 94413, 94192, 96007, 94134, 94414, 94395, 96008, 94135, 94415, 94398, 96009, 94137, 94416, 94451, 96010, 94138, 94412, 94389, 96006, 94115, 94453, 94457, 96011, 94116, 94459, 94466, 96012, 94117, 94468, 94470, 96013, 94118, 94471, 94491, 96030, 94176, 94225, 94251, 96000, 94177, 94427, 94255, 96001, 94178, 94428, 96302, 96023, 94179, 94429, 94258, 96002, 94182, 95005, 96303, 96024, 20092, 20093, 20094, 20095, 20096, 20098, 20124, 20125, 20126, 20128
Asst. No.:	94130
Type of EUT:	Transceiver
Description of EUT:	Ref. to P.ii of test report
Serial Number:	N/A
FCC ID:	V9Q-94130R24
Date of Sample Submitted:	March 30, 2016
Date of Test:	March 30, 2016 to April 26, 2016
Report No.:	16031540HKG-001
Report Date:	May 20, 2016
Environmental Conditions:	Temperature: +10 to 40°C Humidity: 10 to 90%

INTERTEK TESTING SERVICES

GENERAL INFORMATION

(Cont'd)

Description of EUT:	1:16 Scale Assortment - Cars - 1:16 Scale Assortment - Ford Fiesta RS WRC (94131,94411,94386,96005), 1:16 Scale Assortment - 2014 Audi R8 Ultra (94133,94413,94192,96007), 1:16 Scale Assortment - Volkswagen Polo WRC (94134,94414,94395,96008), 1:16 Scale Assortment - MINI Countryman WRC-JCW (94135,94415,94398,96009), 1:16 Scale Assortment - Citroen C-Elysee WTCC (94137,94416, 94451,96010), 1:16 Scale Assortment - Porsche 911 GT3 Cup (94138,94412,94389,96006), 1:16 Scale Nascar - No. 7 Nikko RC / Toy State Chevrolet (94115,94453,94457,96011), 1:16 Scale Nascar - 2016 Dale Earnhardt Jr. Nationwide Chevrolet (94116,94459,94466,96012), 1:16 Scale Nascar - 2016 Jimmie Johnson Lowes Chevrolet (94117,94468,94470,96013), 1:16 Scale Nascar - 2016 Chase Elliot Chevrolet (94118,94471,94491,96030), 1:16 Scale Assortment - Dodge Viper (2014) (94176,94225,94251,96000), 1:16 Scale Assortment - Nissan GT-R (94177,94427,94255,96001), 1:16 Scale Assortment - Porsche 911 GT3RS 4.0 (94178,94428,96302,96023), 1:16 Scale Assortment - 2015 Subaru WRX STI (94179,94429, 94258,96002), 1:16 Scale Assortment - 2015 Subaru WRX STI (94182,95005,96303,96024), Mini Countryman WRC (Germany) - Polizei (20092), Mini Countryman WRC (Turkey) - Polis (20093), Mini Countryman WRC (UK) - Ambulance (20094), Mini Countryman WRC (UK) - Fire Brigade (20095), Mini Countryman WRC (UK) - Police (20096), Porsche 911 (Germany) - Police (20097), Porsche 911 (Netherlands) - Politie (20098), Porsche 911 (Finland) - Politie (20124), Porsche 911 (Danish) - Politie (20125), Porsche 911 (Swedish) - Politie (20126), Porsche 911 (Norwegian) - Politie (20128)
---------------------	--

INTERTEK TESTING SERVICES

SUMMARY OF TEST RESULT

TEST SPECIFICATION	REFERENCE	RESULTS
Radiated Emission Radiated Emission on the Bandedge	15.249, 15.209	Pass
Radiated Emission in Restricted Bands	15.205	Pass

The equipment under test is found to be complying with the following standards:
FCC Part 15, October 1, 2014 Edition

- Note: 1. The EUT uses a permanently attached antenna which, in accordance to section 15.203, is considered sufficient to comply with the pervisions of this section.
2. Pursuant to FCC part 15 Section 15.215(c), the 20 dB bandwidth of the emission was contained within the frequency band designated (mentioned as above) which the EUT operated. The effects, if any, from frequency sweeping, frequency hopping, other modulation techniques and frequency stability over excepted variations in temperature and supply voltage were considered.

INTERTEK TESTING SERVICES

Table of Contents

1.0	<u>General Description</u>	1
1.1	Product Description	1
1.2	Related Submittal(s) Grants.....	1
1.3	Test Methodology	1
1.4	Test Facility	2
2.0	<u>System Test Configuration</u>	3
2.1	Justification.....	3
2.2	EUT Exercising Software.....	3
2.3	Special Accessories	3
2.4	Measurement Uncertainty.....	3
2.5	Support Equipment List and Description.....	3
3.0	<u>Emission Results</u>	4
3.1	Field Strength Calculation.....	4
3.2	Radiated Emission Configuration Photograph	5
3.3	Radiated Emission Data	5
4.0	<u>Equipment Photographs</u>	10
5.0	<u>Product Labelling</u>	10
6.0	<u>Technical Specifications</u>	10
7.0	<u>Instruction Manual</u>	10
8.0	<u>Miscellaneous Information</u>	11
8.1	Measured Bandwidth / Radiated Emission on the Bandedge	11
8.2	Discussion of Pulse Desensitization	12
8.3	Calculation of Average Factor.....	12
8.4	Emissions Test Procedures	14
9.0	<u>Equipment List</u>	17

INTERTEK TESTING SERVICES

1.0 General Description

1.1 Product Description

The Equipment Under Test (EUT) is a portable 2.4GHz Transceiver (Car Unit) for a RC Controller from 2410-2475MHz with 1MHz channel spacing. The EUT is powered by 4 X 1.5V AA batteries. After switch on the EUT and paired with car, the car can be controlled to move forward, backward, turning left/right direction by the controller.

The Model: 94411, 94386, 96005, 94133, 94413, 94192, 96007, 94134, 94414, 94395, 96008, 94135, 94415, 94398, 96009, 94137, 94416, 94451, 96010, 94138, 94412, 94389, 96006, 94115, 94453, 94457, 96011, 94116, 94459, 94466, 96012, 94117, 94468, 94470, 96013, 94118, 94471, 94491, 96030, 94176, 94225, 94251, 96000, 94177, 94427, 94255, 96001, 94178, 94428, 96302, 96023, 94179, 94429, 94258, 96002, 94182, 95005, 96303, 96024, 20092, 20093, 20094, 20095, 20096, 20098, 20124, 20125, 20126 and 20128 are the same as the Model: 94131 in hardware aspect. The models are different in outer casing and package only.

Antenna Type: Internal, Integral

For electronic filing, the brief circuit description is saved with filename: descri.pdf.

1.2 Related Submittal(s) Grants

This is a single application for certification of a transceiver.

The Certification procedure of transceiver (i.e. Controller) for this transceiver (with FCC ID: V9Q-94370T24) is being processed as the same time of this application.

1.3 Test Methodology

Radiated emission measurements was performed according to the procedures in ANSI C63.10 (2013). All radiated measurements were performed in an 3m Chamber. Preliminary scans were performed in the 3m Chamber only to determine worst case modes. All radiated tests were performed at an antenna to EUT distance of 3 meters, unless stated otherwise in the “**Justification Section**” of this Application.

INTERTEK TESTING SERVICES

1.4 Test Facility

The 3m Chamber facility used to collect the radiated data is located at Workshop No. 3, G/F., World-Wide Industrial Centre, 43-47 Shan Mei Street, Fo Tan, Sha Tin, N.T., Hong Kong. This test facility and site measurement data have been placed on file with the FCC.

INTERTEK TESTING SERVICES

2.0 **System Test Configuration**

2.1 Justification

The system was configured for testing in a typical fashion (as a customer would normally use it), and in the confines as outlined in ANSI C63.10 (2013).

The device was powered by new 4 X 1.5V AA batteries.

For maximizing emissions, the EUT was rotated through 360°, the antenna height was varied from 1 meter to 4 meters above the ground plane, and the antenna polarization was changed. This step by step procedure for maximizing emissions led to the data reported in Exhibit 3.0.

The unit was operated standalone and placed in the center of the turntable.

The equipment under test (EUT) was configured for testing in a typical fashion (as a customer would normally use it). The EUT was mounted to a plastic stand if necessary and placed on the wooden turntable, which enabled the engineer to maximize emissions through its placement in the three orthogonal axes.

2.2 EUT Exercising Software

There was no special software to exercise the device. Once the unit is powered up, it transmits the RF signal continuously.

2.3 Special Accessories

There are no special accessories necessary for compliance of this product.

2.4 Measurement Uncertainty

When determining of the test conclusion, the Measurement Uncertainty of test has been considered.

2.5 Support Equipment List and Description

N/A.

INTERTEK TESTING SERVICES

3.0 Emission Results

Data is included of the worst case configuration (the configuration which resulted in the highest emission levels). A sample calculation, configuration photographs and data tables of the emissions are included.

3.1 Field Strength Calculation

The field strength is calculated by adding the Antenna Factor and Cable Factor, and subtracting the Amplifier Gain (if any), Average Factor (optional) from the measured reading. The basic equation with a sample calculation is as follows:

$$FS = RA + AF + CF - AG - AV$$

where

- FS = Field Strength in dB μ V/m
- RA = Receiver Amplitude (including preamplifier) in dB μ V
- CF = Cable Attenuation Factor in dB
- AF = Antenna Factor in dB
- AG = Amplifier Gain in dB
- AV = Average Factor in dB

In the following table(s), the reading shown on the data table reflects the preamplifier gain. An example for the calculations in the following table is as follows:

$$FS = RR + LF$$

where

- FS = Field Strength in dB μ V/m
- RR = RA - AG - AV in dB μ V
- LF = CF + AF in dB

Assume a receiver reading of 52.0 dB μ V is obtained. The antenna factor of 7.4 dB and cable factor of 1.6 dB are added. The amplifier gain of 29 dB and average factor of 5 dB are subtracted, giving a field strength of 27 dB μ V/m. This value in dB μ V/m was converted to its corresponding level in μ V/m.

$$\begin{aligned} RA &= 52.0 \text{ dB}\mu\text{V/m} \\ AF &= 7.4 \text{ dB} & RR &= 18.0 \text{ dB}\mu\text{V} \\ CF &= 1.6 \text{ dB} & LF &= 9.0 \text{ dB} \\ AG &= 29.0 \text{ dB} \\ AV &= 5.0 \text{ dB} \\ FS &= RR + LF \\ FS &= 18 + 9 = 27 \text{ dB}\mu\text{V/m} \end{aligned}$$

$$\text{Level in } \mu\text{V/m} = \text{Common Antilogarithm } [(27 \text{ dB}\mu\text{V/m})/20] = 22.4 \mu\text{V/m}$$

INTERTEK TESTING SERVICES

3.2 Radiated Emission Configuration Photograph

The worst case in radiated emission was found at 2400 MHz

For electronic filing, the worst case radiated emission configuration photographs are saved with filename: radiated photos.pdf.

3.3 Radiated Emission Data

The data on the following page lists the significant emission frequencies, the limit and the margin of compliance. Numbers with a minus sign are below the limit.

Judgment: Passed by 13.6 dB

INTERTEK TESTING SERVICES

Applicant: Toy State International Limited
 Model: 94131
 Worst-Case Operating Mode: Transmitting

Date of Test: April 26, 2016

Table 1
Radiated Emissions
 Pursuant to FCC Part 15 Section 15.249 Requirement

Lowest Channel

Polari- zation	Frequency (MHz)	Reading (dB μ V)	Pre-Amp Gain (dB)	Antenna Factor (dB)	Net at 3m - Peak (dB μ V/m)	Average Factor (dB)	Calculated at 3m (dB μ V/m)	Average Limit at 3m (dB μ V/m)	Margin (dB)
H	2410.000	72.3	33	29.4	68.7	22.3	46.4	94.0	-47.6
H	2400.000	64.0	33	29.4	60.4	22.3	38.1	54.0	-15.9
H	4820.000	38.1	33	34.9	40.0	22.3	17.7	54.0	-36.3
H	7230.000	37.7	33	37.9	42.6	22.3	20.3	54.0	-33.7
H	9640.000	38.4	33	40.4	45.8	22.3	23.5	54.0	-30.5
H	12050.000	41.6	33	40.5	49.1	22.3	26.8	54.0	-27.2
H	14460.000	43.6	33	40.0	50.6	22.3	28.3	54.0	-25.7

Polari- zation	Frequency (MHz)	Reading (dB μ V)	Pre-Amp Gain (dB)	Antenna Factor (dB)	Net at 3m - Peak (dB μ V/m)	Peak Limit at 3m (dB μ V/m)	Margin (dB)
H	2410.000	72.3	33	29.4	68.7	114.0	-45.3
H	2400.000	64.0	33	29.4	60.4	74.0	-13.6
H	4820.000	38.1	33	34.9	40.0	74.0	-34.0
H	7230.000	37.7	33	37.9	42.6	74.0	-31.4
H	9640.000	38.4	33	40.4	45.8	74.0	-28.2
H	12050.000	41.6	33	40.5	49.1	74.0	-24.9
H	14460.000	43.6	33	40.0	50.6	74.0	-23.4

- NOTES: 1. Peak Detector Data unless otherwise stated.
2. All measurements were made at 3 meters. Harmonic emissions not detected at the 3-meter distances were measured at 0.3-meter and an inverse proportional extrapolation was performed to compare the signal level to the 3-meter limit. No other harmonic emissions than those reported were detected at a test distance of 0.3-meter.
3. Negative sign in the column shows value below limit.
4. Horn antenna is used for the emission over 1000MHz.
5. Emission (the row indicated by **bold italic**) within the restricted band meets the requirement of FCC Part 15 Section 15.205.
6. Measurement Uncertainty is ± 5.3 dB at a level of confidence of 95%.

INTERTEK TESTING SERVICES

Applicant: Toy State International Limited
 Model: 94131
 Worst-Case Operating Mode: Transmitting

Date of Test: April 26, 2016

Table 2
Radiated Emissions
 Pursuant to FCC Part 15 Section 15.249 Requirement

Middle Channel

Polarization	Frequency (MHz)	Reading (dB μ V)	Pre-Amp Gain (dB)	Antenna Factor (dB)	Net at 3m - Peak (dB μ V/m)	Average Factor (dB)	Calculated at 3m (dB μ V/m)	Average Limit at 3m (dB μ V/m)	Margin (dB)
H	2440.000	73.9	33	29.4	70.3	22.3	48.0	94.0	-46.0
H	4880.000	37.1	33	34.9	39.0	22.3	16.7	54.0	-37.3
H	7320.000	38.0	33	37.9	42.9	22.3	20.6	54.0	-33.4
H	9760.000	38.3	33	40.4	45.7	22.3	23.4	54.0	-30.6
H	12200.000	41.9	33	40.5	49.4	22.3	27.1	54.0	-26.9
H	14640.000	45.5	33	38.4	50.9	22.3	28.6	54.0	-25.4

Polarization	Frequency (MHz)	Reading (dB μ V)	Pre-Amp Gain (dB)	Antenna Factor (dB)	Net at 3m - Peak (dB μ V/m)	Peak Limit at 3m (dB μ V/m)	Margin (dB)
H	2440.000	73.9	33	29.4	70.3	114.0	-43.7
H	4880.000	37.1	33	34.9	39.0	74.0	-35.0
H	7320.000	38.0	33	37.9	42.9	74.0	-31.1
H	9760.000	38.3	33	40.4	45.7	74.0	-28.3
H	12200.000	41.9	33	40.5	49.4	74.0	-24.6
H	14640.000	45.5	33	38.4	50.9	74.0	-23.1

- NOTES: 1. Peak Detector Data unless otherwise stated.
2. All measurements were made at 3 meters. Harmonic emissions not detected at the 3-meter distances were measured at 0.3-meter and an inverse proportional extrapolation was performed to compare the signal level to the 3-meter limit. No other harmonic emissions than those reported were detected at a test distance of 0.3-meter.
3. Negative sign in the column shows value below limit.
4. Horn antenna is used for the emission over 1000MHz.
5. Emission (the row indicated by **bold italic**) within the restricted band meets the requirement of FCC Part 15 Section 15.205.
6. Measurement Uncertainty is ± 5.3 dB at a level of confidence of 95%.

INTERTEK TESTING SERVICES

Applicant: Toy State International Limited
 Model: 94131
 Worst-Case Operating Mode: Transmitting

Date of Test: April 26, 2016

Table 3
Radiated Emissions
 Pursuant to FCC Part 15 Section 15.249 Requirement

Highest Channel

Polarization	Frequency (MHz)	Reading (dB μ V)	Pre-Amp Gain (dB)	Antenna Factor (dB)	Net at 3m - Peak (dB μ V/m)	Average Factor (dB)	Calculated at 3m (dB μ V/m)	Average Limit at 3m (dB μ V/m)	Margin (dB)
H	2475.000	71.6	33	29.4	68.0	22.3	45.7	94.0	-48.3
H	2483.500	63.5	33	29.4	59.9	22.3	37.6	54.0	-16.4
H	4950.000	40.2	33	34.9	42.1	22.3	19.8	54.0	-34.2
H	7425.000	38.6	33	37.9	43.5	22.3	21.2	54.0	-32.8
H	9900.000	39.0	33	40.4	46.4	22.3	24.1	54.0	-29.9
H	12375.000	41.8	33	40.5	49.3	22.3	27.0	54.0	-27.0
H	14850.000	45.6	33	38.4	51.0	22.3	28.7	54.0	-25.3

Polarization	Frequency (MHz)	Reading (dB μ V)	Pre-Amp Gain (dB)	Antenna Factor (dB)	Net at 3m - Peak (dB μ V/m)	Peak Limit at 3m (dB μ V/m)	Margin (dB)
H	2475.000	71.6	33	29.4	68.0	114.0	-46.0
H	2483.500	63.5	33	29.4	59.9	74.0	-14.1
H	4950.000	40.2	33	34.9	42.1	74.0	-31.9
H	7425.000	38.6	33	37.9	43.5	74.0	-30.5
H	9900.000	39.0	33	40.4	46.4	74.0	-27.6
H	12375.000	41.8	33	40.5	49.3	74.0	-24.7
H	14850.000	45.6	33	38.4	51.0	74.0	-23.0

- NOTES: 1. Peak Detector Data unless otherwise stated.
2. All measurements were made at 3 meters. Harmonic emissions not detected at the 3-meter distances were measured at 0.3-meter and an inverse proportional extrapolation was performed to compare the signal level to the 3-meter limit. No other harmonic emissions than those reported were detected at a test distance of 0.3-meter.
3. Negative sign in the column shows value below limit.
4. Horn antenna is used for the emission over 1000MHz.
5. Emission (the row indicated by **bold italic**) within the restricted band meets the requirement of FCC Part 15 Section 15.205.
6. Measurement Uncertainty is ± 5.3 dB at a level of confidence of 95%.

INTERTEK TESTING SERVICES

Applicant: Toy State International Limited
Model: 94131
Worst-Case Operating Mode: Transmitting

Date of Test: April 26, 2016

Table 4
Radiated Emissions
Pursuant to FCC Part 15 Section 15.209 Requirement

Polarization	Frequency (MHz)	Reading (dB μ V)	Pre-amp (dB)	Antenna Factor (dB)	Net at 3m (dB μ V/m)	Limit at 3m (dB μ V/m)	Margin (dB)
H	31.865	19.8	16	10.0	13.8	40.0	-26.2
H	112.970	19.7	16	14.0	17.7	43.5	-25.8
H	119.125	22.9	16	14.0	20.9	43.5	-22.6
H	175.292	9.0	16	19.0	12.0	43.5	-31.5
H	530.941	7.6	16	27.0	18.6	46.0	-27.4
H	803.163	7.4	16	31.0	22.4	46.0	-23.6

- NOTES: 1. Peak Detector Data unless otherwise stated.
2. All measurements were made at 3 meters. Harmonic emissions not detected at the 3-meter distances were measured at 0.3-meter and an inverse proportional extrapolation was performed to compare the signal level to the 3-meter limit. No other harmonic emissions than those reported were detected at a test distance of 0.3-meter.
3. Negative sign in the column shows value below limit.
4. Horn antenna is used for the emission over 1000MHz.
5. Emission (the row indicated by **bold italic**) within the restricted band meets the requirement of FCC Part 15 Section 15.205.
6. Measurement Uncertainty is ± 5.3 dB at a level of confidence of 95%.

INTERTEK TESTING SERVICES

4.0 **Equipment Photographs**

For electronic filing, the photographs are saved with filename: external photos.pdf and internal photos.pdf.

5.0 **Product Labelling**

For electronics filing, the FCC ID label artwork and the label location are saved with filename: label.pdf.

6.0 **Technical Specifications**

For electronic filing, the block diagram and schematic of the tested EUT are saved with filename: block.pdf and circuit.pdf respectively.

7.0 **Instruction Manual**

For electronic filing, a preliminary copy of the Instruction Manual is saved with filename: manual.pdf.

This manual will be provided to the end-user with each unit sold/leased in the United States.

INTERTEK TESTING SERVICES

8.0 Miscellaneous Information

The miscellaneous information includes details of the test procedure and measured bandwidth / calculation of factor such as pulse desensitization and averaging factor (calculation and timing diagram).

8.1 Radiated Emission on the Bandedge

The test data of bandedge emissions were shown on the above radiated emissions table 1 and table 3 respectively.

Emissions radiated outside of the specified frequency bands, except harmonics, are attenuated by 50dB below the level of the fundamental or to the general radiated emissions limits in Section 15.209, whichever is the lesser attenuation, which meet the requirement of part 15.249(d).

The resultant field strength meets the general radiated emission limit in section 15.209, which does not exceed 74 dB μ V/m (Peak Limit) but exceeded 54 dB μ V/m (Average Limit).

INTERTEK TESTING SERVICES

8.2 Discussion of Pulse Desensitization

Pulse desensitivity is not applicable for this device. The effective period (Teff) is approximately 2.56ms for a digital "1" bit which illustrated on technical specification, with a resolution bandwidth (3dB) of 1MHz, so the pulse desensitivity factor is 0dB.

8.3 Calculation of Average Factor

The duty cycle is simply the on-time divided by the period:

The duration of one cycle = 100ms

Effective period of the cycle = $2.56 \times 3 = 7.68\text{ms}$

DC = $7.68/100 = 0.0768$

Therefore, the averaging factor is found by $20\log 0.0768 = -22.3\text{dB}$.

INTERTEK TESTING SERVICES

Average Factor

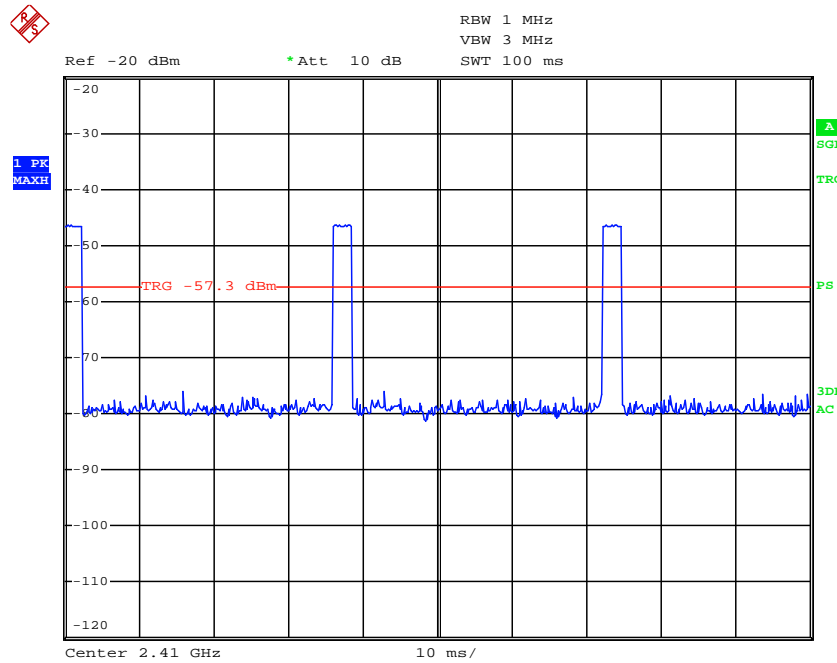
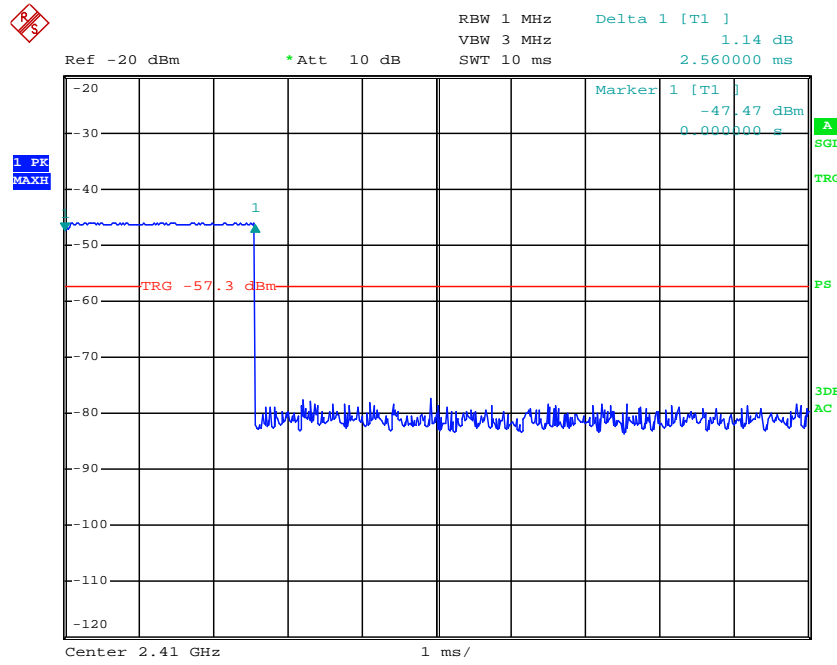

INTERTEK TESTING SERVICES

8.4 Emissions Test Procedures

The following is a description of the test procedure used by Intertek Testing Services Hong Kong Ltd. in the measurements of transmitter operating under the Part 15, Subpart C rules.

The transmitting equipment under test (EUT) is placed on a wooden turntable which is four feet in diameter and approximately 0.8m in height above the ground plane for emission measurement at or below 1GHz and 1.5m in height above the ground plane for emission measurement above 1GHz. During the radiated emissions test, the turntable is rotated and any cables leaving the EUT are manipulated to find the configuration resulting in maximum emissions. The EUT is adjusted through all three orthogonal axis to obtain maximum emission levels. The antenna height and polarization are also varied during the testing to search for maximum signal levels. The height of the antenna is varied from one to four meters.

Detector function for radiated emissions is in peak mode. Average readings, when required, are taken by measuring the duty cycle of the equipment under test and subtracting the corresponding amount in dB from the measured peak readings. A detailed description for the calculation of the average factor can be found in Exhibit 8.3.

The frequency range scanned is from the lowest radio frequency signal generated in the device which is greater than 9 kHz to the tenth harmonic of the highest fundamental frequency or 40 GHz, whichever is lower.

INTERTEK TESTING SERVICES

8.4 Emissions Test Procedures (cont'd)

The EUT is warmed up for 15 minutes prior to the test.

AC power to the unit is varied from 85% to 115% nominal and variation in the fundamental emission field strength is recorded. If battery powered, a new, fully charged battery is used.

Conducted measurements were made as described in ANSI C63.10 (2013).

The IF bandwidth used for measurement of radiated signal strength was 100 kHz or greater when frequency is below 1000 MHz. Where pulsed transmissions of short enough pulse duration warrant, a greater bandwidth is selected according to the recommendations of Hewlett Packard Application Note 150-2. A discussion of whether pulse desensitivity is applicable to this unit is included in this report (See Exhibit 8.1). Above 1000 MHz, a resolution bandwidth of 3 MHz is used.

Transmitter measurements are normally conducted at a measurement distance of three meters. However, to assure low enough noise floor in the forbidden bands and above 1 GHz, signals are acquired at a distance of one meter or less. All measurements are extrapolated to three meters using inverse scaling, unless otherwise reported. Measurements taken at a closer distance are so marked.

INTERTEK TESTING SERVICES

8.4.1 Radiated Emission Test Setup

The figure below shows the test setup, which is utilized to make these measurements.

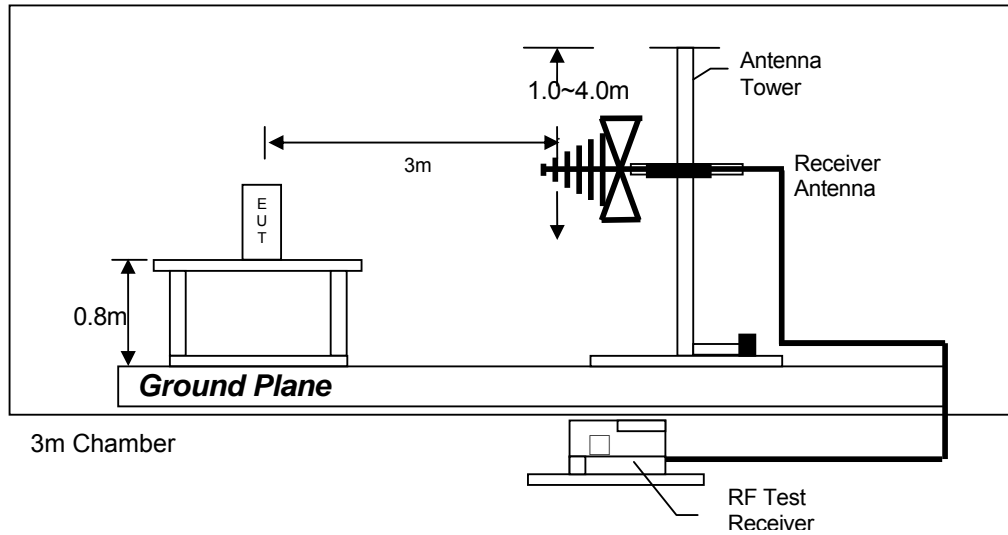

Test setup of radiated emissions up to 1GHz

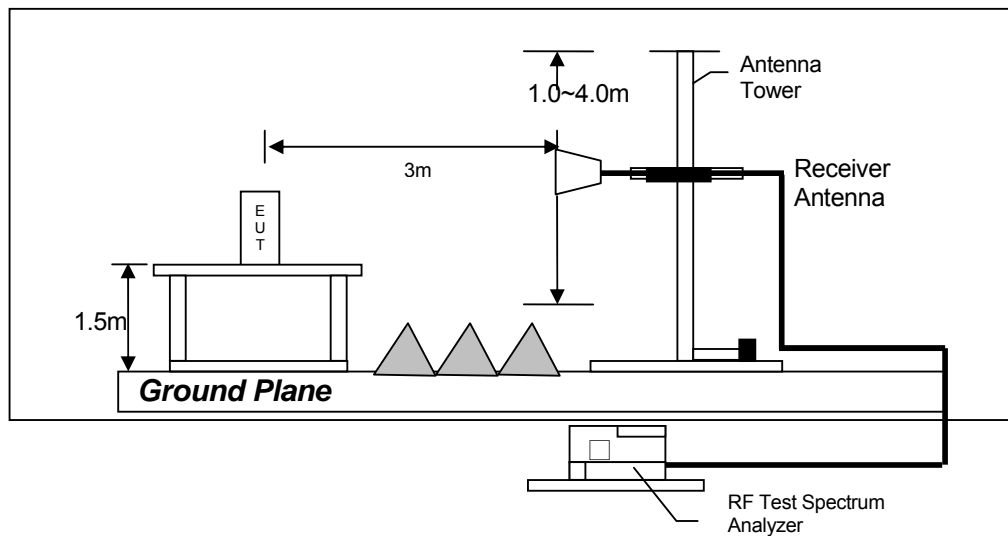

Test setup of radiated emissions above 1GHz

INTERTEK TESTING SERVICES

9.0 Equipment List

1) Radiated Emissions Test

Equipment	EMI Test Receiver	Spectrum Analyzer	BiConiLog Antenna
Registration No.	EW-3156	EW-2253	EW-3061
Manufacturer	R&S	R&S	EMCO
Model No.	ESR26	FSP40	3412E
Calibration Date	Nov. 03, 2015	May 27, 2015	Jul. 22, 2015
Calibration Due Date	Nov. 03, 2016	May 27, 2016	Jul. 22, 2016

Equipment	Double Ridged Guide Antenna
Registration No.	EW-0194
Manufacturer	EMCO
Model No.	3115
Calibration Date	Jan. 29, 2015
Calibration Due Date	Jul. 29, 2016

2) Average Factor Measurement

Equipment	Spectrum Analyzer
Registration No.	EW-2329
Manufacturer	R&S
Model No.	FSP3
Calibration Date	Jun. 17, 2015
Calibration Due Date	Jun. 17, 2016

END OF TEST REPORT