



Shenzhen CTL Electromagnetic Technology Co., Ltd.
Tel: +86-755-89486194 Fax: +86-755-89486187

FCC PART 15 SUBPART C TEST REPORT

FCC Part 15.227

Report Reference No......: **CTL11058262-S-WF**

Compiled by

(position+printed name+signature)...: File administrators Andy Zhang

Andy Zhang

Name of the organization performing the tests

Test Engineer Kendy Wang

Kendy Wang

(position+printed name+signature)...

Approved by

(position+printed name+signature)...: Manager Tracy Qi

Tracy Qi

Date of issue.....: May 17, 2011

Representative Laboratory Name : **Shenzhen CTL Electromagnetic Technology Co., Ltd.**

Address.....: Zone B, 4/F, Block 20, Guangqian Industrial Park, Longzhu Road, Nanshan, Shenzhen 518055 China.

Test Firm.....: **Bontek Compliance Testing Laboratory Ltd**

Address.....: 1/F, Block East H-3, OCT Eastern Ind. Zone, Qiaocheng East Road, Nanshan, Shenzhen, China

Applicant's name.....: **Toy State International Ltd.**

Address.....: 19/F, One Peking, No1 Peking Road Tsimshatsui, Kowloon, Hong Kong

Test specification:

Standard: **FCC Part 15.227: Operation within the band 26.96–27.28 MHz.**

TRF Originator.....: Shenzhen CTL Electromagnetic Technology Co., Ltd.

Master TRF.....: Dated 2011-01

Shenzhen CTL Electromagnetic Technology Co., Ltd. All rights reserved.

This publication may be reproduced in whole or in part for non-commercial purposes as long as the Shenzhen CTL Electromagnetic Technology Co., Ltd. is acknowledged as copyright owner and source of the material. Shenzhen CTL Electromagnetic Technology Co., Ltd. takes no responsibility for and will not assume liability for damages resulting from the reader's interpretation of the reproduced material due to its placement and context.

Test item description : Heavy Duty

Trade Mark: /

Model/Type reference.....: 36665

Modulation: AM

Work Frequency.....: 27.145 MHz

Antenna Type.....: Undetachable

Power Supply.....: DC 4.5V from battery

FCC ID: V9Q-36665F27

Result.....: **Positive**

TEST REPORT

Test Report No. :	CTL11058262S-WF	May 17, 2011
		Date of issue

Equipment under Test : Heavy Duty

Model /Type : 36665

Applicant : **Toy State International Ltd.**

Address : 19/F, One Peking, No1 Peking Road Tsimshatsui,
Kowloon, Hong Kong

Manufacturer **Shen Zhen Nan Ling Toys Products Co, Ltd**

Address 132 Busha Road, Nanling Village, Buji Town Longgang
Shenzhen, Canton, China

Test Result according to the
standards on page 4:

Positive

The test report merely corresponds to the test sample.
It is not permitted to copy extracts of these test result without the written permission of the test
laboratory.

Contents

1.	<u>TEST STANDARDS</u>	<u>4</u>
2.	<u>SUMMARY</u>	<u>5</u>
2.1.	General Remarks	5
2.2.	Equipment Under Test	5
2.3.	Short description of the Equipment under Test (EUT)	5
2.4.	EUT operation mode	5
2.5.	EUT configuration	5
2.6.	Related Submittal(s) / Grant (s)	6
2.7.	Modifications	6
3.	<u>TEST ENVIRONMENT</u>	<u>7</u>
3.1.	Address of the test laboratory	7
3.2.	Test Facility	7
3.3.	Environmental conditions	7
3.4.	Configuration of Tested System	7
3.5.	Statement of the measurement uncertainty	8
3.6.	Equipments Used during the Test	8
4.	<u>TEST CONDITIONS AND RESULTS</u>	<u>9</u>
4.1.	Conducted Emissions Test	9
4.2.	Radiated Emission Test	10
4.3.	Occupied Bandwidth	13
4.4.	Antenna Requirement	14
5.	<u>TEST SETUP PHOTOS OF THE EUT</u>	<u>15</u>
6.	<u>EXTERNAL AND INTERNAL PHOTOS OF THE EUT</u>	<u>16</u>

1. TEST STANDARDS

The tests were performed according to following standards:

[FCC Rules Part 15.227](#): Operation within the band 26.96–27.28 MHz.

[ANSI C63.4-2003](#)



2. SUMMARY

2.1. General Remarks

Date of receipt of test sample : May 8, 2011

Testing commenced on : May 9, 2011

Testing concluded on : May 12, 2011

2.2. Equipment Under Test

Power supply system utilised

Power supply voltage : 120V / 60 Hz 115V / 60Hz
 12 V DC 24 V DC
 Other (specified in blank below)

DC 4.5V from battery

2.3. Short description of the Equipment under Test (EUT)

Wireless toy controller work at 27.145 MHz.

For more details, refer to the user's manual of the EUT.

Serial number: Prototype

2.4. EUT operation mode

The EUT has been tested under typical operating condition.

2.5. EUT configuration

The following peripheral devices and interface cables were connected during the measurement:

- supplied by the manufacturer

- supplied by the lab

Length (m) : /

Shield : /

Detachable : /

Manufacturer :

Model No. :

2.6. Related Submittal(s) / Grant (s)

This submittal(s) (test report) is intended for FCC ID: **V9Q-36665F27** filing to comply with Section 15.227 of the FCC Part 15, Subpart C Rules.

2.7. Modifications

No modifications were implemented to meet testing criteria.



3. TEST ENVIRONMENT

3.1. Address of the test laboratory

Bontek Compliance Testing Laboratory Ltd
 1/F, Block East H-3, OCT Eastern Ind. Zone, Qiaocheng East Road, Nanshan, Shenzhen, China

The sites are constructed in conformance with the requirements of ANSI C63.7, ANSI C63.4 (2003) and CISPR Publication 22.

3.2. Test Facility

The test facility is recognized, certified, or accredited by the following organizations:

IC Registration No.: 7631A

The 3m alternate test site of Bontek Compliance Testing Laboratory Ltd EMC Laboratory has been registered by Certification and Engineer Bureau of Industry Canada for the performance of with Registration NO.: 7631A on March, 2008.

FCC-Registration No.: 338263

Bontek Compliance Testing Laboratory Ltd EMC Laboratory has been registered and fully described in a report filed with the (FCC) Federal Communications Commission. The acceptance letter from the FCC is maintained in our files. Registration 338263, March 24, 2008.

3.3. Environmental conditions

During the measurement the environmental conditions were within the listed ranges:

Temperature: 15-35 ° C

Humidity: 30-60 %

Atmospheric pressure: 950-1050mbar

3.4. Configuration of Tested System

Fig. 2-1 Configuration of Tested System

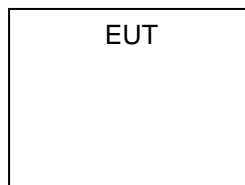

Table 2-1 Equipment Used in Tested System

No.	Product	Manufacturer	Model No.	Serial No.	FCC ID

3.5. Statement of the measurement uncertainty

The data and results referenced in this document are true and accurate. The reader is cautioned that there may be errors within the calibration limits of the equipment and facilities. The measurement uncertainty was calculated for all measurements listed in this test report acc. to CISPR 16 - 4 „Specification for radio disturbance and immunity measuring apparatus and methods – Part 4: Uncertainty in EMC Measurements“ and is documented in the Bontek Compliance Testing Laboratory Ltd quality system acc. to DIN EN ISO/IEC 17025. Furthermore, component and process variability of devices similar to that tested may result in additional deviation. The manufacturer has the sole responsibility of continued compliance of the device.

Hereafter the best measurement capability for Bontek laboratory is reported:

Test	Range	Measurement Uncertainty	Notes
Radiated Emission	30~1000MHz	4.10dB	(1)
Radiated Emission	1~12.75GHz	4.32dB	(1)
Conducted Disturbance	0.15~30MHz	3.20dB	(1)

(1) This uncertainty represents an expanded uncertainty expressed at approximately the 95% confidence level using a coverage factor of k=2.

(2)

3.6. Equipments Used during the Test

For Radiated Spurious Emission (30~25GHz) test:

Radiated Emission						
Item	Test Equipment	Manufacturer	Model No.	Serial No.	Last Cal.	Due. Date
1	LOG ANTENNA	ELECTRO-METRICS	EM-6950	25415	2011/04/14	2012/04/13
2	EMI TEST RECEIVER	ROHDE & SCHWARZ	ESCI	100259	2011/04/14	2012/04/13
3	RF TEST PANEL	ROHDE & SCHWARZ	TS / RSP	335015/0017	2011/04/14	2012/04/13
4	TURNTABLE	ETS	2088	2149	2011/04/14	2012/04/13
5	ANTENNA MAST	ETS	2075	2346	2011/04/14	2012/04/13
6	EMI TEST SOFTWARE	ROHDE & SCHWARZ	ESK1	N/A	2011/04/14	2012/04/13
7	Loop Antenna	ROHDE & SCHWARZ	HFH2-Z2	8335211/0035	2011/04/14	2012/04/13

4. TEST CONDITIONS AND RESULTS

4.1. Conducted Emissions Test

TEST CONFIGURATION

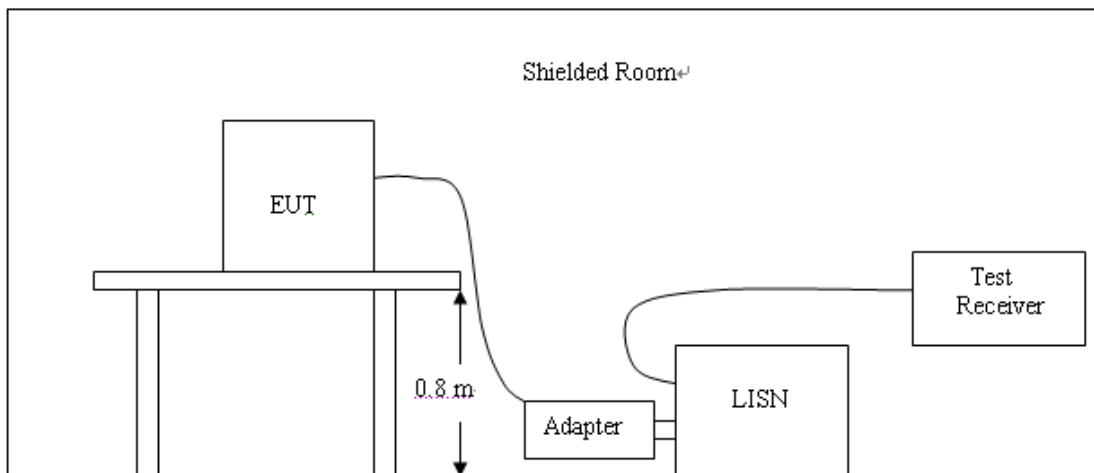

TEST PROCEDURE

- 1 The equipment was set up as per the test configuration to simulate typical actual usage per the user's manual. The EUT is a tabletop system, a wooden table with a height of 0.8 meters is used and is placed on the ground plane as per ANSI C63.4.
- 2 Support equipment, if needed, was placed as per ANSI C63.4.
- 3 All I/O cables were positioned to simulate typical actual usage as per ANSI C63.4.
- 4 If a EUT received DC power from the adapter, the adapter received AC120V/60Hz power through a Line Impedance Stabilization Network (LISN) which supplied power source and was grounded to the ground plane.
- 5 All support equipments received AC power from a second LISN, if any.
- 6 The EUT test program was started. Emissions were measured on each current carrying line of the EUT using a spectrum Analyzer / Receiver connected to the LISN powering the EUT. The LISN has two monitoring points: Line 1 (Hot Side) and Line 2 (Neutral Side). Two scans were taken: one with Line 1 connected to Analyzer / Receiver and Line 2 connected to a 50 ohm load; the second scan had Line 1 connected to a 50 ohm load and Line 2 connected to the Analyzer / Receiver.
- 7 Analyzer / Receiver scanned from 150 KHz to 30MHz for emissions in each of the test modes.
- 8 During the above scans, the emissions were maximized by cable manipulation.

Conducted Power Line Emission Limit

For unintentional device, according to § 15.107(a) Line Conducted Emission Limits is as following :

Frequency (MHz)	Maximum RF Line Voltage (dB μ V)			
	CLASS A		CLASS B	
	Q.P.	Ave.	Q.P.	Ave.
0.15 - 0.50	79	66	66-56*	56-46*
0.50 - 5.00	73	60	56	46
5.00 - 30.0	73	60	60	50

* Decreasing linearly with the logarithm of the frequency

For intentional device, according to §15.207(a) Line Conducted Emission Limit is same as above table.

TEST RESULTS

Owing to the DC operation of EUT, this test item is not performed.

4.2. Radiated Emission Test

TEST CONFIGURATION

(A) Radiated Emission Test Set-Up, Frequency Below 30MHz

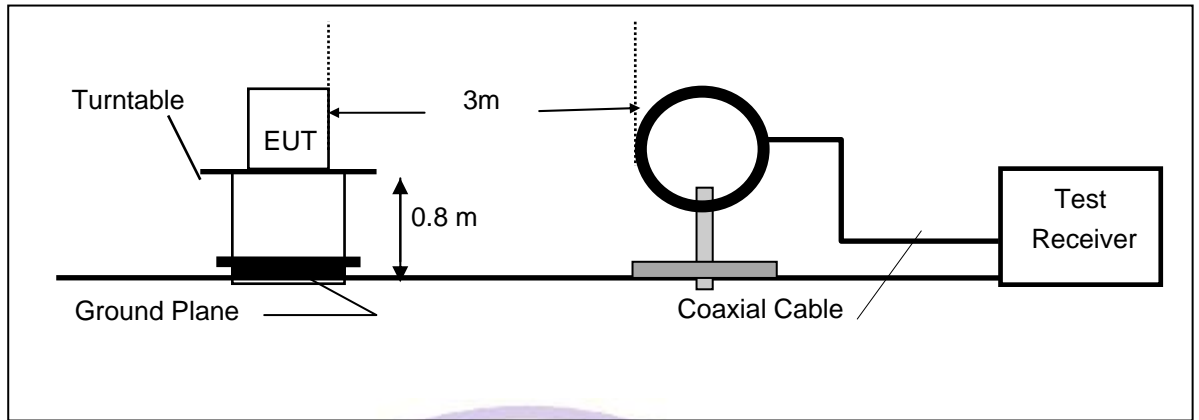

(B) Radiated Emission Test Set-Up, Frequency below 1000MHz

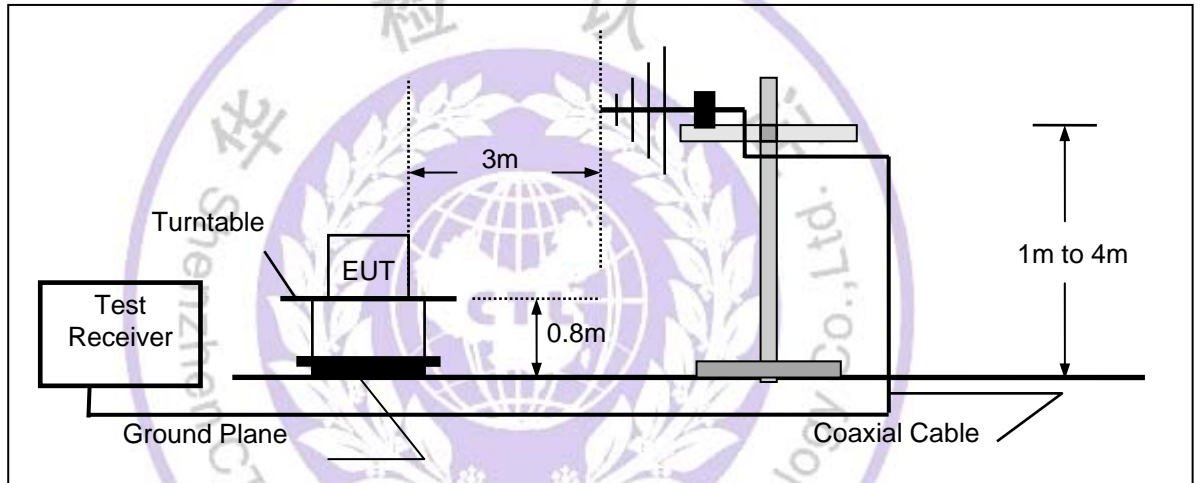

(C) Radiated Emission Test Set-Up, Frequency above 1000MHz

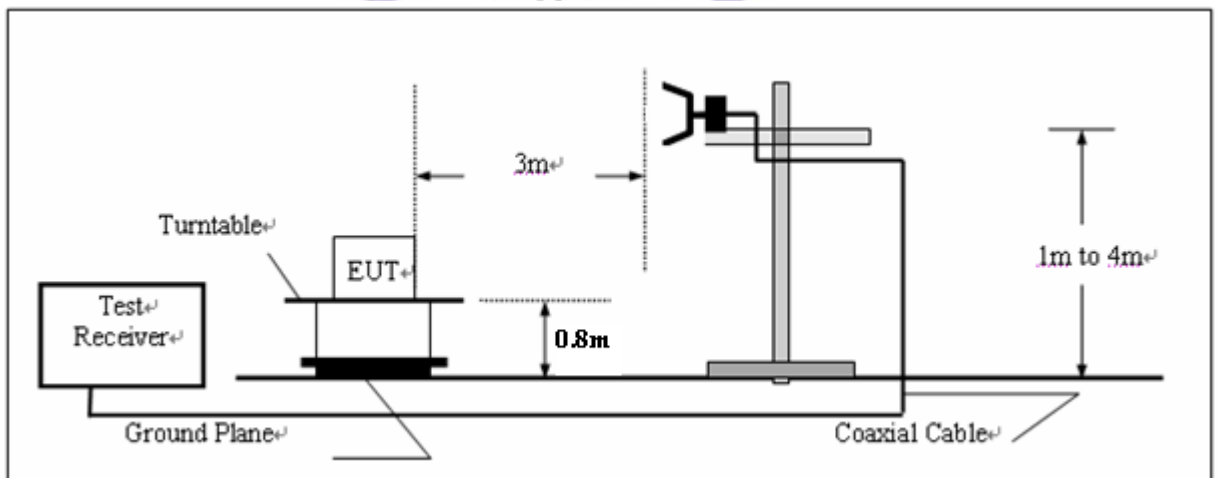

Field Strength Calculation

The field strength is calculated by adding the Antenna Factor and Cable Factor and subtracting the Amplifier Gain and Duty Cycle Correction Factor(if any) from the measured reading. The basic equation with a sample calculation is as follows:

$$FS = RA + AF + CL - AG$$

Where FS = Field Strength	CL = Cable Attenuation Factor (Cable Loss)
RA = Reading Amplitude	AG = Amplifier Gain
AF = Antenna Factor	

Radiation Limit

For unintentional device, according to § 15.109(a), except for Class A digital devices, the field strength of radiated emissions from unintentional radiators at a distance of 3 meters shall not exceed the following values:

Frequency (MHz)	Distance (Meters)	Radiated (dBµV/m)	Radiated (µV/m)
30-88	3	40.0	100
88-216	3	43.5	150
216-960	3	46.0	200
Above 960	3	54.0	500

For intentional device, according to § 15.209(a), the general requirement of field strength of radiated emissions from intentional radiators at a distance of 3 meters shall not exceed the above table.

Test Procedure

1. The EUT is placed on a turntable, which is 0.8m above ground plane.
2. The turntable shall be rotated for 360 degrees to determine the position of maximum emission level.
3. EUT is set 3m away from the receiving antenna, which is varied from 1m to 4m to find out the highest emissions.
4. Maximum procedure was performed on the six highest emissions to ensure EUT compliance.
5. And also, each emission was to be maximized by changing the polarization of receiving antenna both horizontal and vertical.
6. Repeat above procedures until the measurements for all frequencies are complete.

Note:

Three axes are chosen for pretest, the Z axis is the worst mode for final test.

For battery operated equipment, the equipment tests shall be performed using a new battery.

TEST RESULTS

Freq. (MHz)	Ant.Pol. H/V	DetectorMode (PK/AV)	Reading (dBuV)	Ant./CL/ Amp. CF(dB)	Actual FS (dBuV/m)	Limit3m (dBuV/m)	Safe Margin (dB)	Note
27.145	Loop	Peak	45.40	21.20	66.60	80.00	-13.40	F
54.290	V	Peak	21.80	8.30	30.10	40.00	-9.90	H
81.435	V	Peak	10.90	11.40	22.30	40.00	-17.70	H
108.580	V	Peak	11.47	11.63	23.10	43.50	-20.40	H
135.725	V	Peak	10.36	10.14	20.50	43.50	-23.00	H
162.870	V	Peak	9.90	10.70	20.60	43.50	-22.90	H
190.015	V	Peak	18.60	10.70	29.30	43.50	-14.20	H
217.160	V	Peak	20.50	11.10	31.60	46.00	-14.40	H
Others			-					

Freq. (MHz)	Ant.Pol. H/V	DetectorMode (PK/AV)	Reading (dBuV)	Ant./CL/ Amp. CF(dB)	Actual FS (dBuV/m)	Limit3m (dBuV/m)	Safe Margin (dB)	Note
27.145	Loop	Peak	45.40	21.20	66.60	80.00	-13.40	F
54.290	H	Peak	18.40	8.30	26.70	40.00	-13.30	H
81.435	H	Peak	8.70	11.40	20.10	40.00	-19.90	H
108.580	H	Peak	17.07	11.63	28.70	43.50	-14.80	H
135.725	H	Peak	10.66	10.14	20.80	43.50	-22.70	H
162.870	H	Peak	9.90	10.70	20.60	43.50	-22.90	H
190.015	H	Peak	12.50	10.70	23.20	43.50	-20.30	H
217.160	H	Peak	9.60	11.10	20.70	46.00	-25.30	H
Others			-					

Remark:

- (1) Measuring frequencies from 25 MHz to the 1GHz.
- (2) "F" denotes fundamental frequency; "H" denotes spurious frequency. "E" denotes band edge frequency.
- (3) * denotes emission frequency which appearing within the Restricted Bands specified in provision of 15.205, then the general radiated emission limits in 15.209 apply.
- (4) Datas of measurement within this frequency range shown "-" in the table above means the reading of emissions are attenuated more than 20dB below the permissible limits or the field strength is too small to be measured.
- (5) The IF bandwidth of EMI Test Receiver between 25MHz to 1GHz was 120KHz.

4.3. Occupied Bandwidth

TEST CONFIGURATION

Same as Section 4.2

TEST PROCEDURE

1. The EUT was placed on a turn table which is 0.8m above ground plane.
2. Set EUT as normal operation
3. Based on FCC Part15 C Section 15.227: Operation within the band 26.96 – 27.28 MHz, RBW= 10KHz, VBW= 30KHz.
4. The useful radiated emission from the EUT was detected by the spectrum analyser with peak detector.

LIMIT

The field strength of any emissions which appear outside of the band shall not exceed the general radiated emission limits in section 15.209.

TEST RESULTS

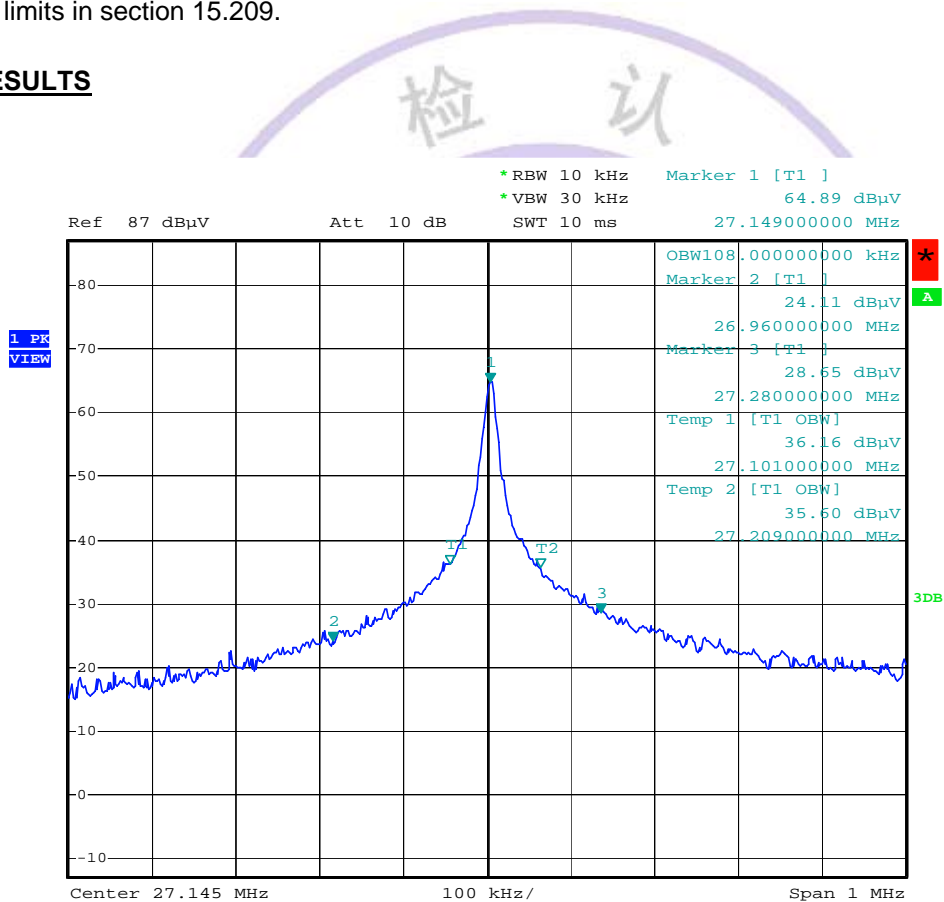

Date: 12.MAY.2011 15:56:24

4.4. Antenna Requirement

STANDARD APPLICABLE

For intentional device, according to FCC 47 CFR Section 15.203, an intentional radiator shall be designed to ensure that no antenna other than that furnished by the responsible party shall be used with the device.

And according to FCC 47 CFR Section 15.247 (c), if transmitting antennas of directional gain greater than 6dBi are used, the power shall be reduced by the amount in dB that the directional gain of the antenna exceeds 6dBi.

Refer to statement below for compliance.

The manufacturer may design the unit so that the user can replace a broken antenna, but the use of a standard antenna jack or electrical connector is prohibited. Further, this requirement does not apply to intentional radiators that must be professionally installed.

ANTENNA CONNECTED CONSTRUCTION

The antenna connector is designed with permanent attachment and no consideration of replacement. Please see EUT photo for details.



5. Test Setup Photos of the EUT



6. External and Internal Photos of the EUT

External Photos



Internal Photos

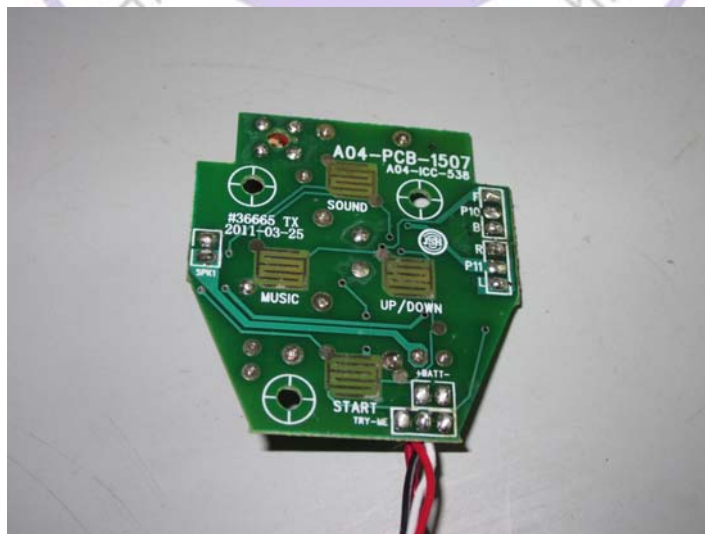

.....End of Report.....