

APPENDIX A: SAR TEST DATA

PCTEST ENGINEERING LABORATORY, INC.

DUT: V8YFWA1FU38000W; Type:USB Dongle; Serial: AWB 1

Communication System: WIMAX - 5 MHz; Frequency: 3652.5 MHz;Duty Cycle: 1:2.7

Medium: 3700 Body Medium parameters used (interpolated):

$f = 3652.5$ MHz; $\sigma = 3.575$ mho/m; $\epsilon_r = 53.239$; $\rho = 1000$ kg/m³

Phantom section: Flat Section; Space: 0.5 cm

Test Date: 06-13-2012; Ambient Temp: 23.0°C; Tissue Temp: 21.4°C

Probe: EX3DV4 - SN3645; ConvF(6.15, 6.15, 6.15); Calibrated: 10/26/2011;

Sensor-Surface: 2mm (Mechanical Surface Detection)

Electronics: DAE4 Sn1333; Calibrated: 4/12/2012

Phantom: SAM 5.0 front; Type: QD000P40CD; Serial: TP:-1648

Measurement SW: DASY52, Version 52.8 (0);SEMCAD X Version 14.6.5 (6469)

**Mode: WIMAX, Low channel, QPSK, 5 MHz Bandwidth, PUSC
Horizontal Up, Antenna 0**

Area Scan (6x11x1): Measurement grid: dx=12mm, dy=12mm

Zoom Scan (7x7x8)/Cube 0: Measurement grid: dx=5mm, dy=5mm, dz=4mm

Reference Value = 11.778 V/m; Power Drift = -0.147 dB

Peak SAR (extrapolated) = 1.397 mW/g

SAR(1 g) = 0.554 mW/g; SAR(10 g) = 0.243 mW/g

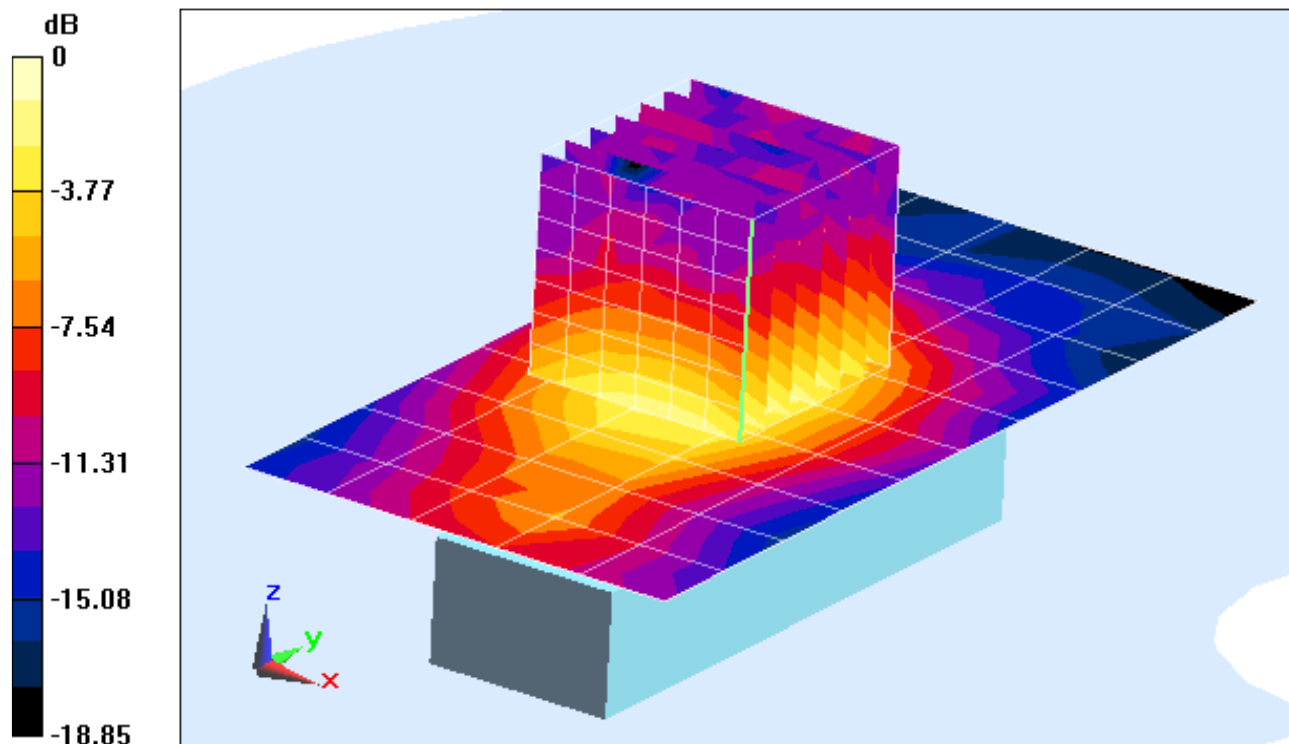

0 dB = 0.866 mW/g = -1.24 dB mW/g

PCTEST ENGINEERING LABORATORY, INC.

DUT: V8YFWA1FU38000W; Type:USB Dongle; Serial: AWB 1

Communication System: WIMAX 3.7 -10 MHz; Frequency: 3662.5 MHz;Duty Cycle: 1:3.2

Medium: 3700 Body Medium parameters used (interpolated):

$f = 3662.5 \text{ MHz}$; $\sigma = 3.591 \text{ mho/m}$; $\epsilon_r = 53.224$; $\rho = 1000 \text{ kg/m}^3$

Phantom section: Flat Section; Space: 0.5 cm

Test Date: 06-13-2012; Ambient Temp: 23.0°C; Tissue Temp: 21.4°C

Probe: EX3DV4 - SN3645; ConvF(6.15, 6.15, 6.15); Calibrated: 10/26/2011;

Sensor-Surface: 2mm (Mechanical Surface Detection)

Electronics: DAE4 Sn1333; Calibrated: 4/12/2012

Phantom: SAM 5.0 front; Type: QD000P40CD; Serial: TP:-1648

Measurement SW: DASY52, Version 52.8 (0);SEMCAD X Version 14.6.5 (6469)

**Mode: WIMAX, Mid. Ch., QPSK, 10 MHz Bandwidth, PUSC
Horizontal Up, Antenna 0**

Area Scan (6x11x1): Measurement grid: dx=12mm, dy=12mm

Zoom Scan (7x7x8)/Cube 0: Measurement grid: dx=5mm, dy=5mm, dz=4mm

Reference Value = 10.684 V/m; Power Drift = -0.16 dB

Peak SAR (extrapolated) = 1.272 mW/g

SAR(1 g) = 0.496 mW/g; SAR(10 g) = 0.214 mW/g

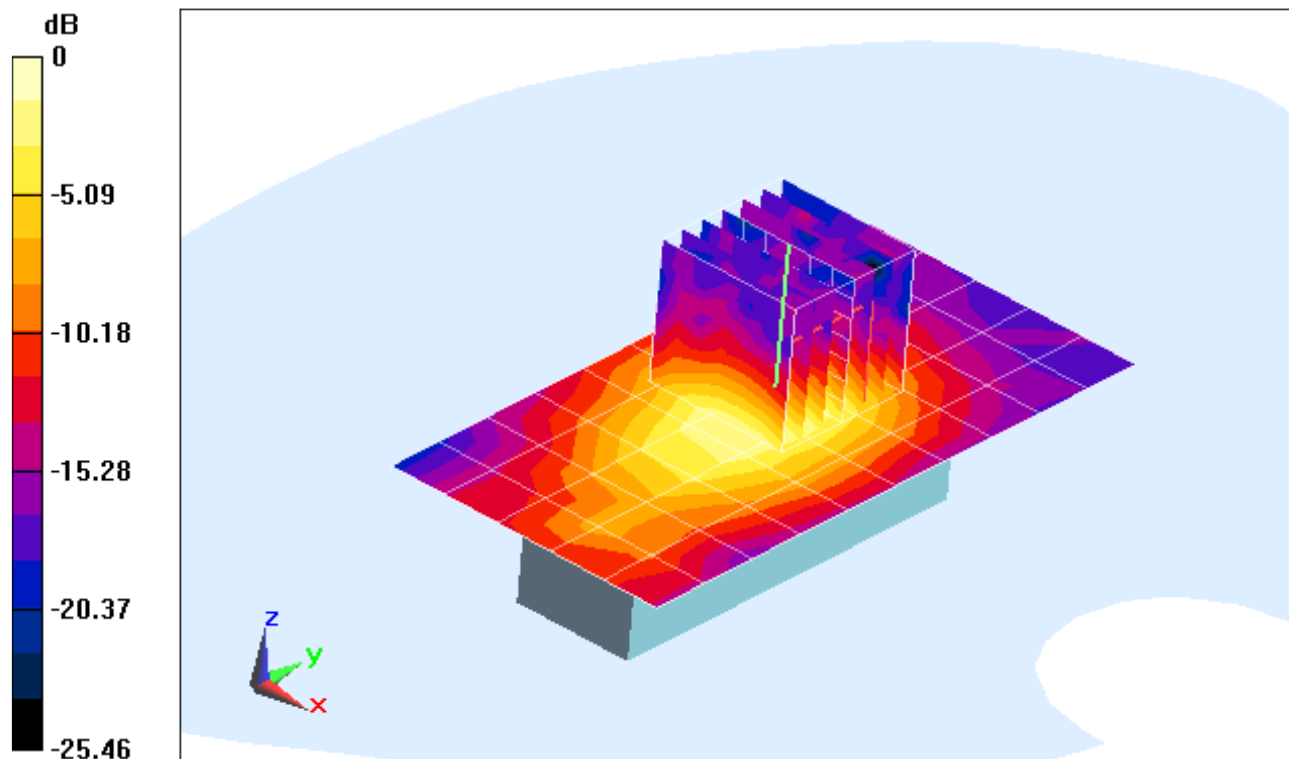

0 dB = 0.834 mW/g = -1.58 dB mW/g

PCTEST ENGINEERING LABORATORY, INC.

DUT: V8YFWA1FU38000W; Type:USB Dongle; Serial: AWB 1

Communication System: WIMAX - 5 MHz; Frequency: 3652.5 MHz;Duty Cycle: 1:2.7

Medium: 3700 Body Medium parameters used (interpolated):

$f = 3652.5 \text{ MHz}$; $\sigma = 3.575 \text{ mho/m}$; $\epsilon_r = 53.239$; $\rho = 1000 \text{ kg/m}^3$

Phantom section: Flat Section; Space: 0.5 cm

Test Date: 06-13-2012; Ambient Temp: 23.0°C; Tissue Temp: 21.4°C

Probe: EX3DV4 - SN3645; ConvF(6.15, 6.15, 6.15); Calibrated: 10/26/2011;

Sensor-Surface: 2mm (Mechanical Surface Detection)

Electronics: DAE4 Sn1333; Calibrated: 4/12/2012

Phantom: SAM 5.0 front; Type: QD000P40CD; Serial: TP:-1648

Measurement SW: DASY52, Version 52.8 (0);SEMCAD X Version 14.6.5 (6469)

**Mode: WIMAX, Low channel, QPSK, 5 MHz Bandwidth, PUSC
Horizontal Down, Antenna 0**

Area Scan (6x11x1): Measurement grid: dx=12mm, dy=12mm

Zoom Scan (7x7x8)/Cube 0: Measurement grid: dx=5mm, dy=5mm, dz=4mm

Reference Value = 12.197 V/m; Power Drift = -0.10 dB

Peak SAR (extrapolated) = 1.833 mW/g

SAR(1 g) = 0.723 mW/g; SAR(10 g) = 0.307 mW/g

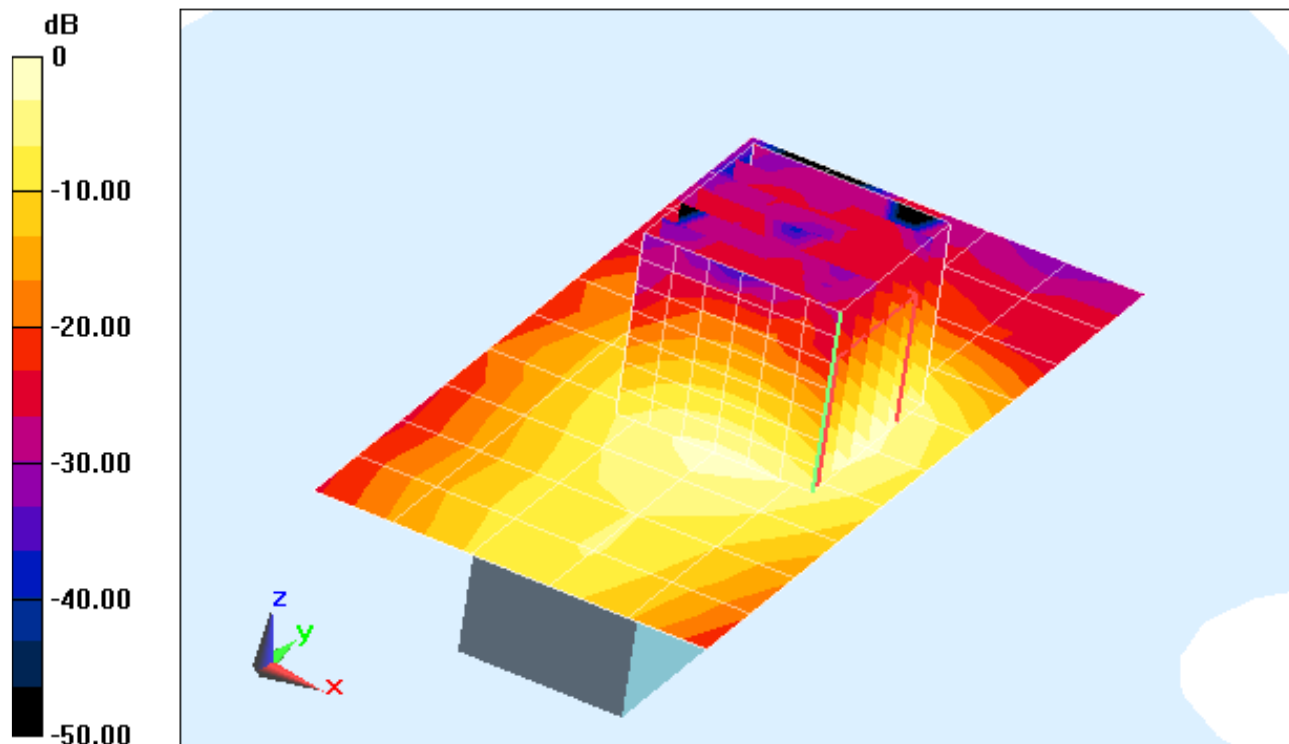

0 dB = 1.08 mW/g = 0.63 dB mW/g

PCTEST ENGINEERING LABORATORY, INC.

DUT: V8YFWA1FU38000W; Type:USB Dongle; Serial: AWB 1

Communication System: WIMAX - 10 MHz; Frequency: 3662.5 MHz; Duty Cycle: 1:3.2

Medium: 3700 Body Medium parameters used (interpolated):

$f = 3662.5$ MHz; $\sigma = 3.591$ mho/m; $\epsilon_r = 53.224$; $\rho = 1000$ kg/m³

Phantom section: Flat Section; Space: 0.5 cm

Test Date: 06-13-2012; Ambient Temp: 23.0°C; Tissue Temp: 21.4°C

Probe: EX3DV4 - SN3645; ConvF(6.15, 6.15, 6.15); Calibrated: 10/26/2011;
Sensor-Surface: 2mm (Mechanical Surface Detection)

Electronics: DAE4 Sn1333; Calibrated: 4/12/2012

Phantom: SAM 5.0 front; Type: QD000P40CD; Serial: TP:-1648

Measurement SW: DASY52, Version 52.8 (0); SEMCAD X Version 14.6.5 (6469)

**Mode: WIMAX, Mid. Ch., QPSK, 10 MHz Bandwidth, PUSC
Horizontal Down, Antenna 0**

Area Scan (6x11x1): Measurement grid: dx=12mm, dy=12mm

Zoom Scan (7x7x8)/Cube 0: Measurement grid: dx=5mm, dy=5mm, dz=4mm

Reference Value = 10.948 V/m; Power Drift = -0.17 dB

Peak SAR (extrapolated) = 1.565 mW/g

SAR(1 g) = 0.596 mW/g; SAR(10 g) = 0.250 mW/g

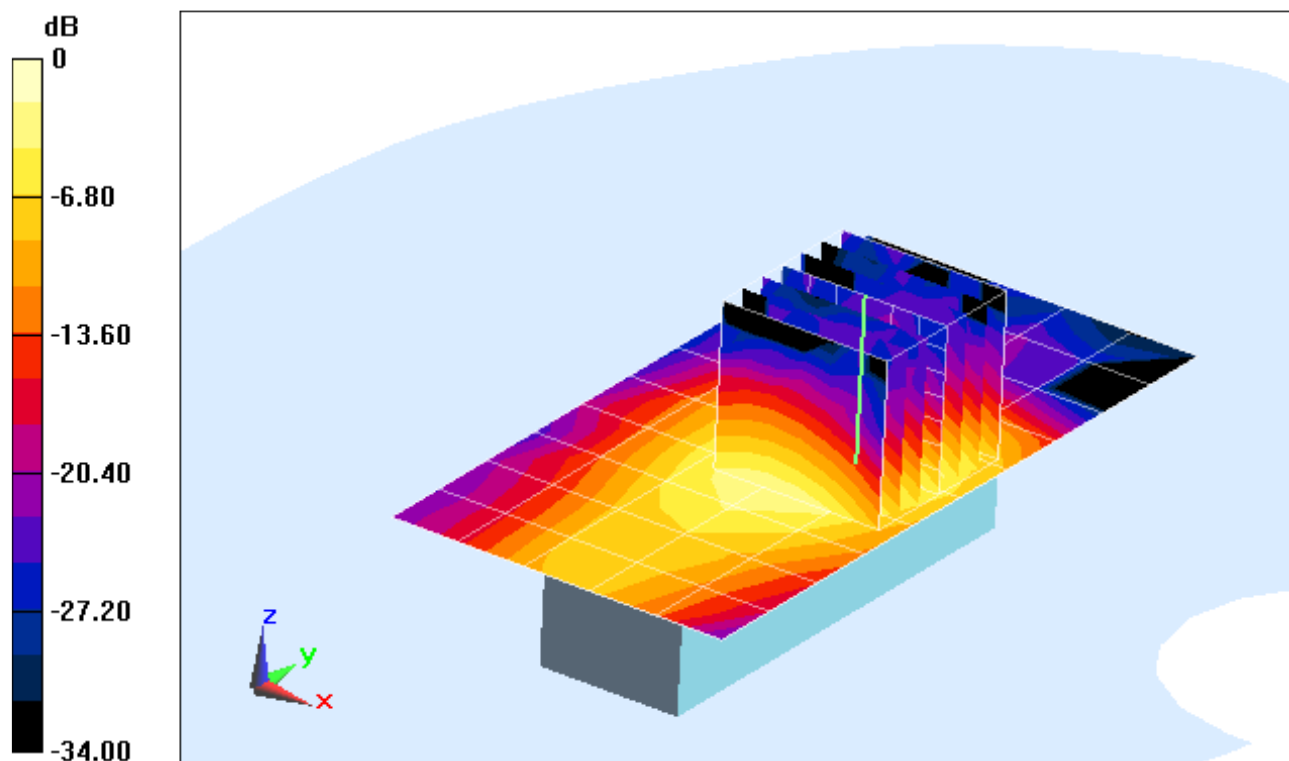

0 dB = 0.991 mW/g = -0.08 dB mW/g

PCTEST ENGINEERING LABORATORY, INC.

DUT: V8YFWA1FU38000W; Type: USB Dongle; Serial: AWB 1

Communication System: WIMAX - 5 MHz; Frequency: 3652.5 MHz; Duty Cycle: 1:2.7

Medium: 3700 Body Medium parameters used (interpolated):

$f = 3652.5 \text{ MHz}$; $\sigma = 3.575 \text{ mho/m}$; $\epsilon_r = 53.239$; $\rho = 1000 \text{ kg/m}^3$

Phantom section: Flat Section; Space: 0.5 cm

Test Date: 06-13-2012; Ambient Temp: 23.0°C; Tissue Temp: 21.4°C

Probe: EX3DV4 - SN3645; ConvF(6.15, 6.15, 6.15); Calibrated: 10/26/2011;

Sensor-Surface: 2mm (Mechanical Surface Detection)

Electronics: DAE4 Sn1333; Calibrated: 4/12/2012

Phantom: SAM 5.0 front; Type: QD000P40CD; Serial: TP:-1648

Measurement SW: DASY52, Version 52.8 (0); SEMCAD X Version 14.6.5 (6469)

**Mode: WIMAX, Low channel, QPSK, 5 MHz Bandwidth, PUSC
Tip, Antenna 0**

Area Scan (6x6x1): Measurement grid: dx=12mm, dy=12mm

Zoom Scan (7x7x8)/Cube 0: Measurement grid: dx=5mm, dy=5mm, dz=4mm

Reference Value = 8.564 V/m; Power Drift = -0.19 dB

Peak SAR (extrapolated) = 0.610 mW/g

SAR(1 g) = 0.230 mW/g; SAR(10 g) = 0.097 mW/g

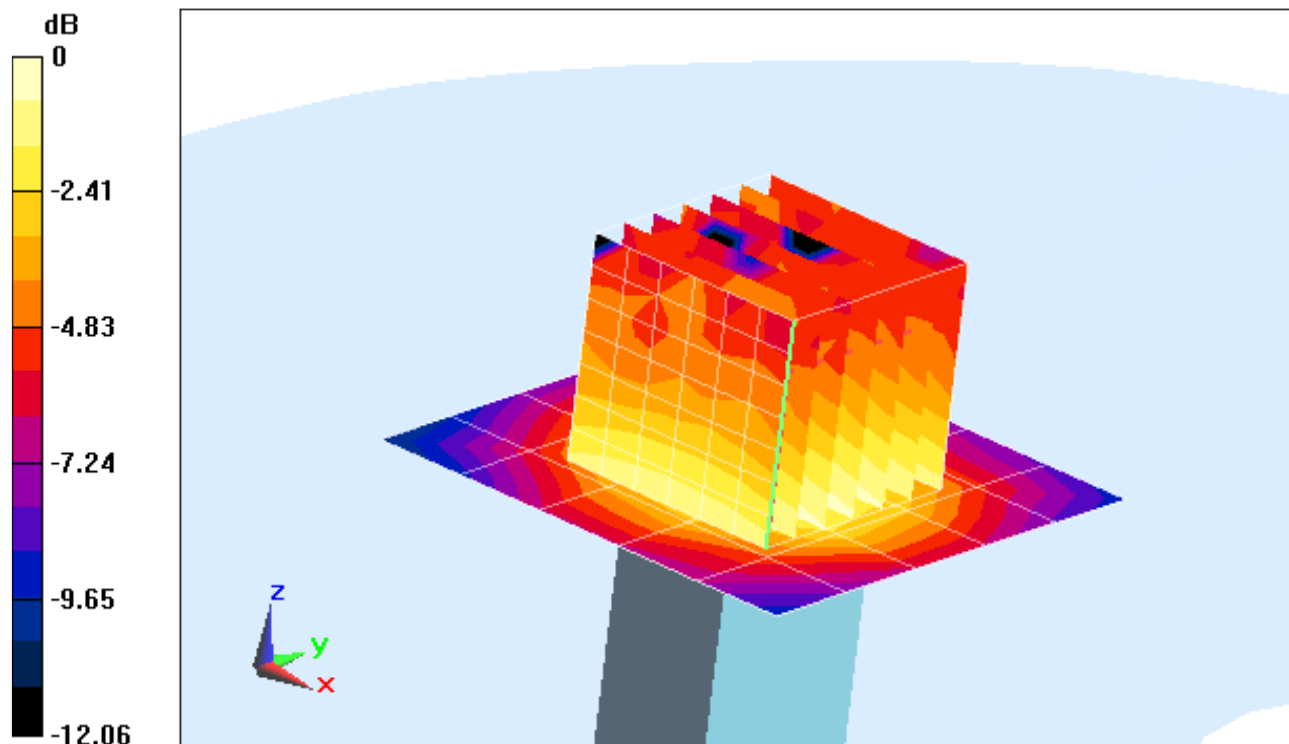

0 dB = 0.335 mW/g = -9.51 dB mW/g

PCTEST ENGINEERING LABORATORY, INC.

DUT: V8YFWA1FU38000W; Type: USB Dongle; Serial: AWB 1

Communication System: WIMAX - 10 MHz; Frequency: 3662.5 MHz; Duty Cycle: 1:3.2

Medium: 3700 Body Medium parameters used (interpolated):

$f = 3662.5$ MHz; $\sigma = 3.591$ mho/m; $\epsilon_r = 53.224$; $\rho = 1000$ kg/m³

Phantom section: Flat Section; Space: 0.5 cm

Test Date: 06-13-2012; Ambient Temp: 23.0°C; Tissue Temp: 21.4°C

Probe: EX3DV4 - SN3645; ConvF(6.15, 6.15, 6.15); Calibrated: 10/26/2011;

Sensor-Surface: 2mm (Mechanical Surface Detection)

Electronics: DAE4 Sn1333; Calibrated: 4/12/2012

Phantom: SAM 5.0 front; Type: QD000P40CD; Serial: TP:-1648

Measurement SW: DASY52, Version 52.8 (0); SEMCAD X Version 14.6.5 (6469)

**Mode: WIMAX, Mid Ch., QPSK, 10 MHz Bandwidth, PUSC
Tip, Antenna 0**

Area Scan (6x6x1): Measurement grid: dx=12mm, dy=12mm

Zoom Scan (7x7x8)/Cube 0: Measurement grid: dx=5mm, dy=5mm, dz=4mm

Reference Value = 6.938 V/m; Power Drift = -0.141 dB

Peak SAR (extrapolated) = 0.431 mW/g

SAR(1 g) = 0.162 mW/g; SAR(10 g) = 0.070 mW/g

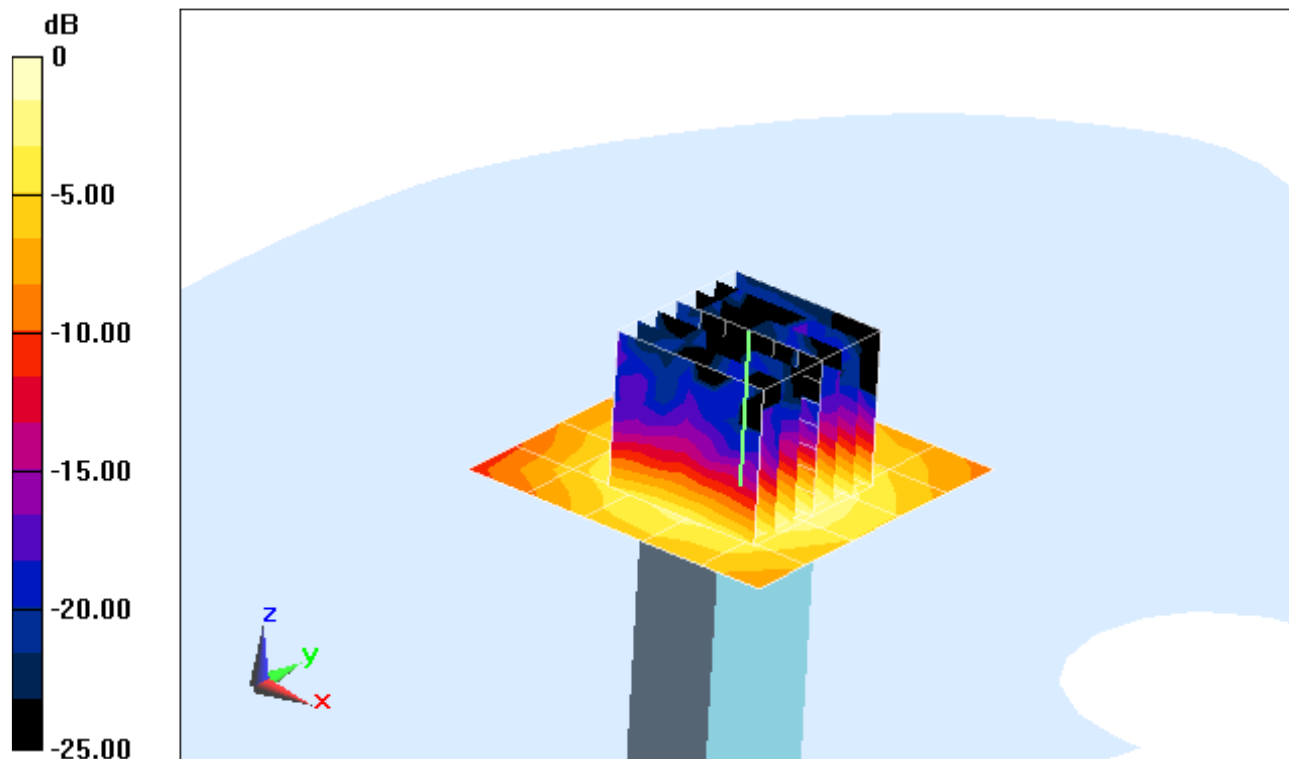

0 dB = 0.271 mW/g = -11.34 dB mW/g

PCTEST ENGINEERING LABORATORY, INC.

DUT: V8YFWA1FU38000W; Type: USB Dongle; Serial: AWB 1

Communication System: WIMAX - 5 MHz; Frequency: 3652.5 MHz; Duty Cycle: 1:2.7

Medium: 3700 Body Medium parameters used (interpolated):

$f = 3652.5$ MHz; $\sigma = 3.575$ mho/m; $\epsilon_r = 53.239$; $\rho = 1000$ kg/m³

Phantom section: Flat Section: Space: 0.5 cm

Test Date: 06-13-2012; Ambient Temp: 23.0°C; Tissue Temp: 21.4°C

Probe: EX3DV4 - SN3645; ConvF(6.15, 6.15, 6.15); Calibrated: 10/26/2011;

Sensor-Surface: 2mm (Mechanical Surface Detection)

Electronics: DAE4 Sn1333; Calibrated: 4/12/2012

Phantom: SAM 5.0 front; Type: QD000P40CD; Serial: TP:-1648

Measurement SW: DASY52, Version 52.8 (0); SEMCAD X Version 14.6.5 (6469)

**Mode: WIMAX, Low channel, QPSK, 5 MHz Bandwidth, PUSC
Vertical Front, Antenna 0**

Area Scan (6x11x1): Measurement grid: dx=12mm, dy=12mm

Zoom Scan (7x7x8)/Cube 0: Measurement grid: dx=5mm, dy=5mm, dz=4mm

Reference Value = 7.412 V/m; Power Drift = -0.04 dB

Peak SAR (extrapolated) = 0.528 mW/g

SAR(1 g) = 0.208 mW/g; SAR(10 g) = 0.094 mW/g

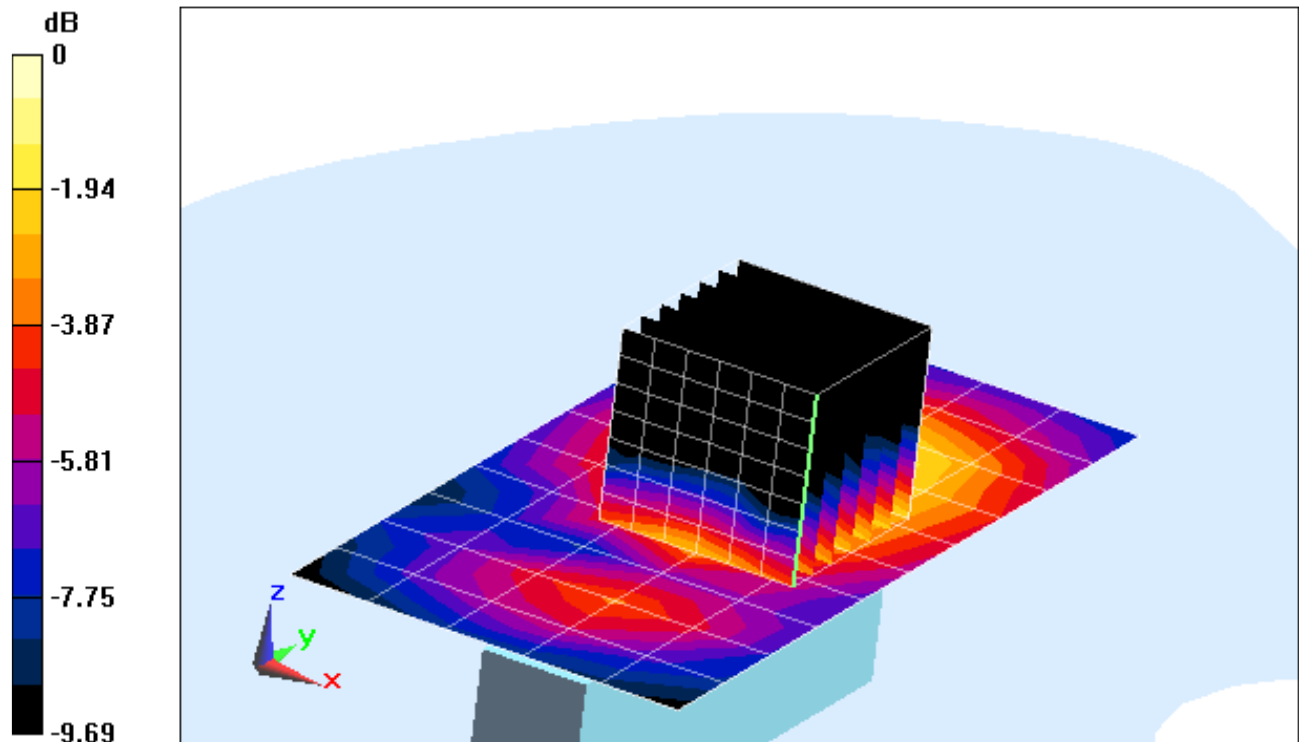

0 dB = 0.349 mW/g = -9.14 dB mW/g

PCTEST ENGINEERING LABORATORY, INC.

DUT: V8YFWA1FU38000W; Type: USB Dongle; Serial: AWB 1

Communication System: WIMAX 3.7 -10 MHz; Frequency: 3662.5 MHz; Duty Cycle: 1:3.2

Medium: 3700 Body Medium parameters used (interpolated):

$f = 3662.5 \text{ MHz}$; $\sigma = 3.591 \text{ mho/m}$; $\epsilon_r = 53.224$; $\rho = 1000 \text{ kg/m}^3$

Phantom section: Flat Section; Space: 0.5 cm

Test Date: 06-13-2012; Ambient Temp: 23.0°C; Tissue Temp: 21.4°C

Probe: EX3DV4 - SN3645; ConvF(6.15, 6.15, 6.15); Calibrated: 10/26/2011;

Sensor-Surface: 2mm (Mechanical Surface Detection)

Electronics: DAE4 Sn1333; Calibrated: 4/12/2012

Phantom: SAM 5.0 front; Type: QD000P40CD; Serial: TP:-1648

Measurement SW: DASY52, Version 52.8 (0); SEMCAD X Version 14.6.5 (6469)

**Mode: WIMAX, Mid Ch., QPSK, 10 MHz Bandwidth, PUSC
Vertical Front, Antenna 0**

Area Scan (6x11x1): Measurement grid: dx=12mm, dy=12mm

Zoom Scan (7x7x8)/Cube 0: Measurement grid: dx=5mm, dy=5mm, dz=4mm

Reference Value = 6.437 V/m; Power Drift = -0.01 dB

Peak SAR (extrapolated) = 0.384 mW/g

SAR(1 g) = 0.151 mW/g; SAR(10 g) = 0.072 mW/g

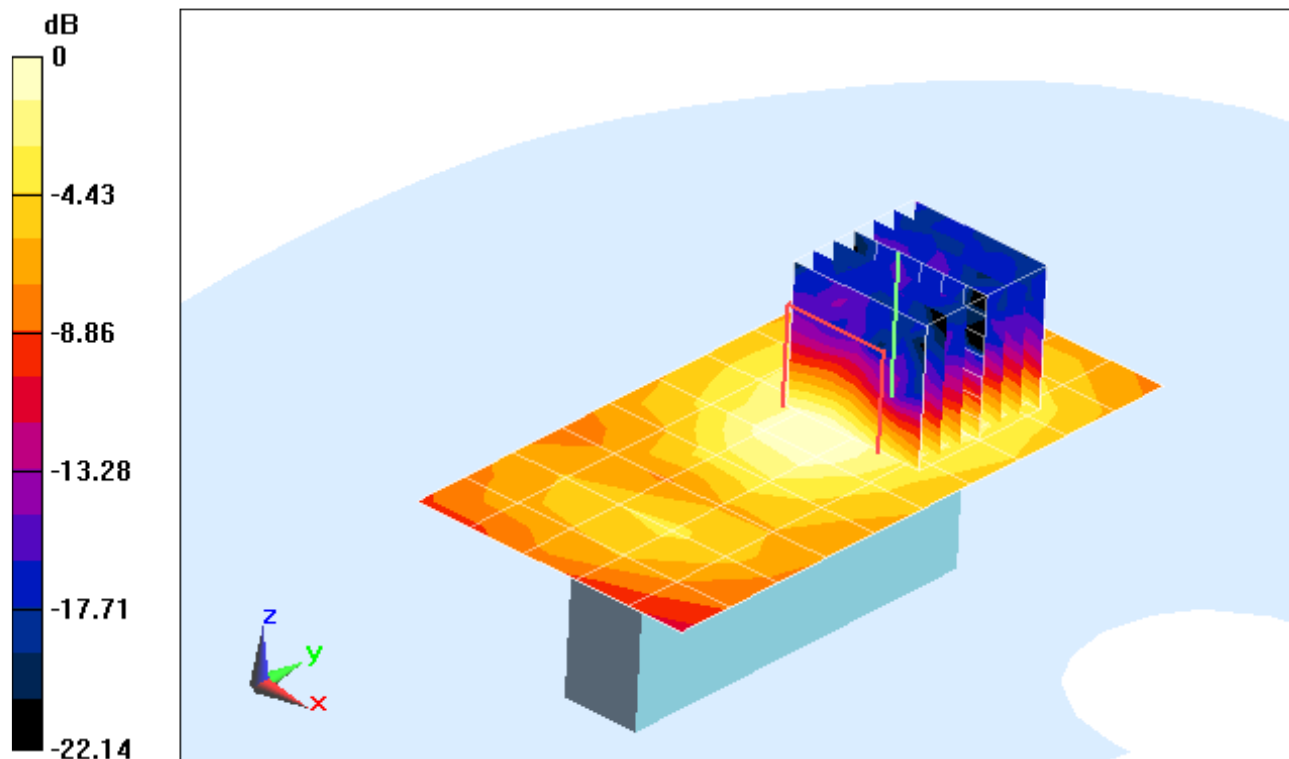

0 dB = 0.249 mW/g = -12.08 dB mW/g

PCTEST ENGINEERING LABORATORY, INC.

DUT: V8YFWA1FU38000W; Type: USB Dongle; Serial: AWB 1

Communication System: WIMAX - 5 MHz; Frequency: 3652.5 MHz; Duty Cycle: 1:2.7

Medium: 3700 Body Medium parameters used (interpolated):

$f = 3652.5$ MHz; $\sigma = 3.575$ mho/m; $\epsilon_r = 53.239$; $\rho = 1000$ kg/m³

Phantom section: Flat Section; Space: 0.5 cm

Test Date: 06-13-2012; Ambient Temp: 23.0°C; Tissue Temp: 21.4°C

Probe: EX3DV4 - SN3645; ConvF(6.15, 6.15, 6.15); Calibrated: 10/26/2011;

Sensor-Surface: 2mm (Mechanical Surface Detection)

Electronics: DAE4 Sn1333; Calibrated: 4/12/2012

Phantom: SAM 5.0 front; Type: QD000P40CD; Serial: TP:-1648

Measurement SW: DASY52, Version 52.8 (0); SEMCAD X Version 14.6.5 (6469)

**Mode: WIMAX, Low channel, QPSK, 5 MHz Bandwidth, PUSC
Vertical Back, Antenna 0**

Area Scan (6x11x1): Measurement grid: dx=12mm, dy=12mm

Zoom Scan (7x7x8)/Cube 0: Measurement grid: dx=5mm, dy=5mm, dz=4mm

Reference Value = 13.061 V/m; Power Drift = -0.05 dB

Peak SAR (extrapolated) = 1.598 mW/g

SAR(1 g) = 0.594 mW/g; SAR(10 g) = 0.245 mW/g

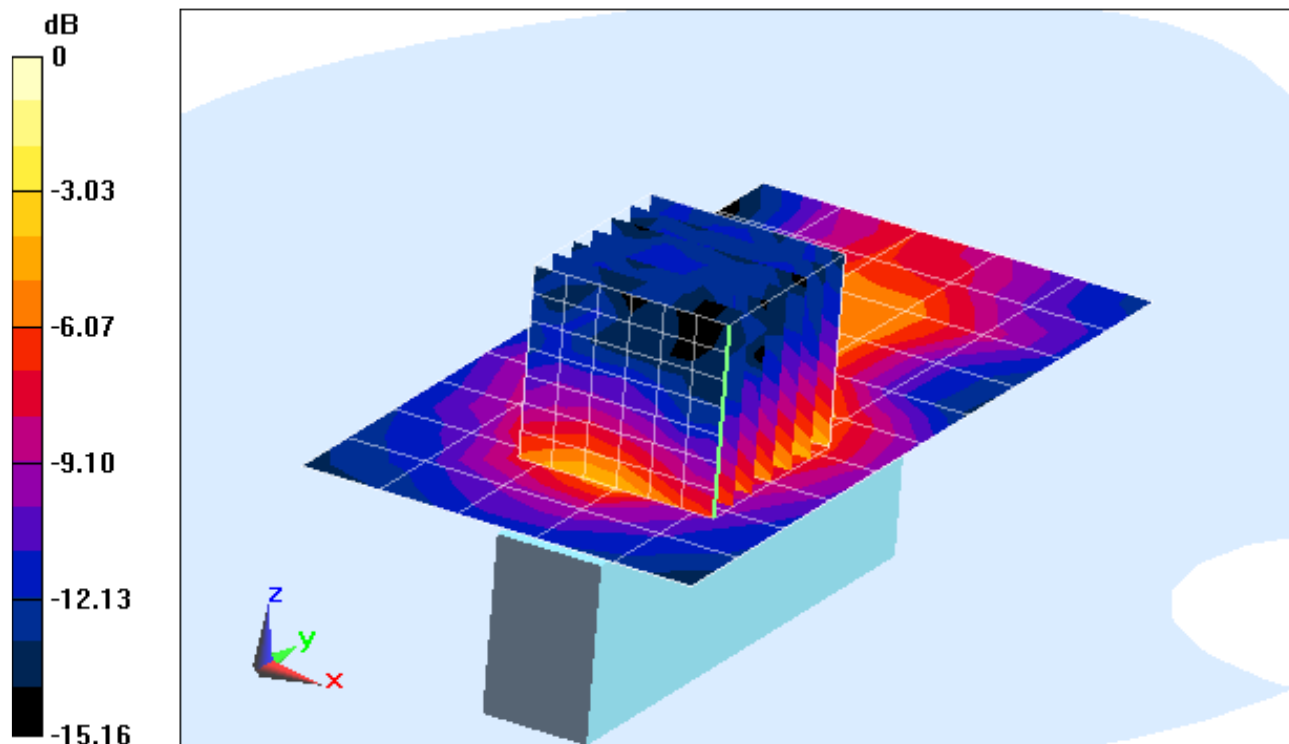

0 dB = 0.890 mW/g = -1.01 dB mW/g

PCTEST ENGINEERING LABORATORY, INC.

DUT: V8YFWA1FU38000W; Type: USB Dongle; Serial: AWB 1

Communication System: WIMAX 3.7 -10 MHz; Frequency: 3662.5 MHz; Duty Cycle: 1:3.2

Medium: 3700 Body Medium parameters used (interpolated):

$f = 3662.5 \text{ MHz}$; $\sigma = 3.591 \text{ mho/m}$; $\epsilon_r = 53.224$; $\rho = 1000 \text{ kg/m}^3$

Phantom section: Flat Section; Space: 0.5 cm

Test Date: 06-13-2012; Ambient Temp: 23.0°C; Tissue Temp: 21.4°C

Probe: EX3DV4 - SN3645; ConvF(6.15, 6.15, 6.15); Calibrated: 10/26/2011;

Sensor-Surface: 2mm (Mechanical Surface Detection)

Electronics: DAE4 Sn1333; Calibrated: 4/12/2012

Phantom: SAM 5.0 front; Type: QD000P40CD; Serial: TP:-1648

Measurement SW: DASY52, Version 52.8 (0); SEMCAD X Version 14.6.5 (6469)

**Mode: WIMAX, Mid Ch., QPSK, 10 MHz Bandwidth, PUSC
Vertical Back, Antenna 0**

Area Scan (6x11x1): Measurement grid: dx=12mm, dy=12mm

Zoom Scan (7x7x8)/Cube 0: Measurement grid: dx=5mm, dy=5mm, dz=4mm

Reference Value = 11.021 V/m; Power Drift = -0.05 dB

Peak SAR (extrapolated) = 1.327 mW/g

SAR(1 g) = 0.475 mW/g; SAR(10 g) = 0.197 mW/g

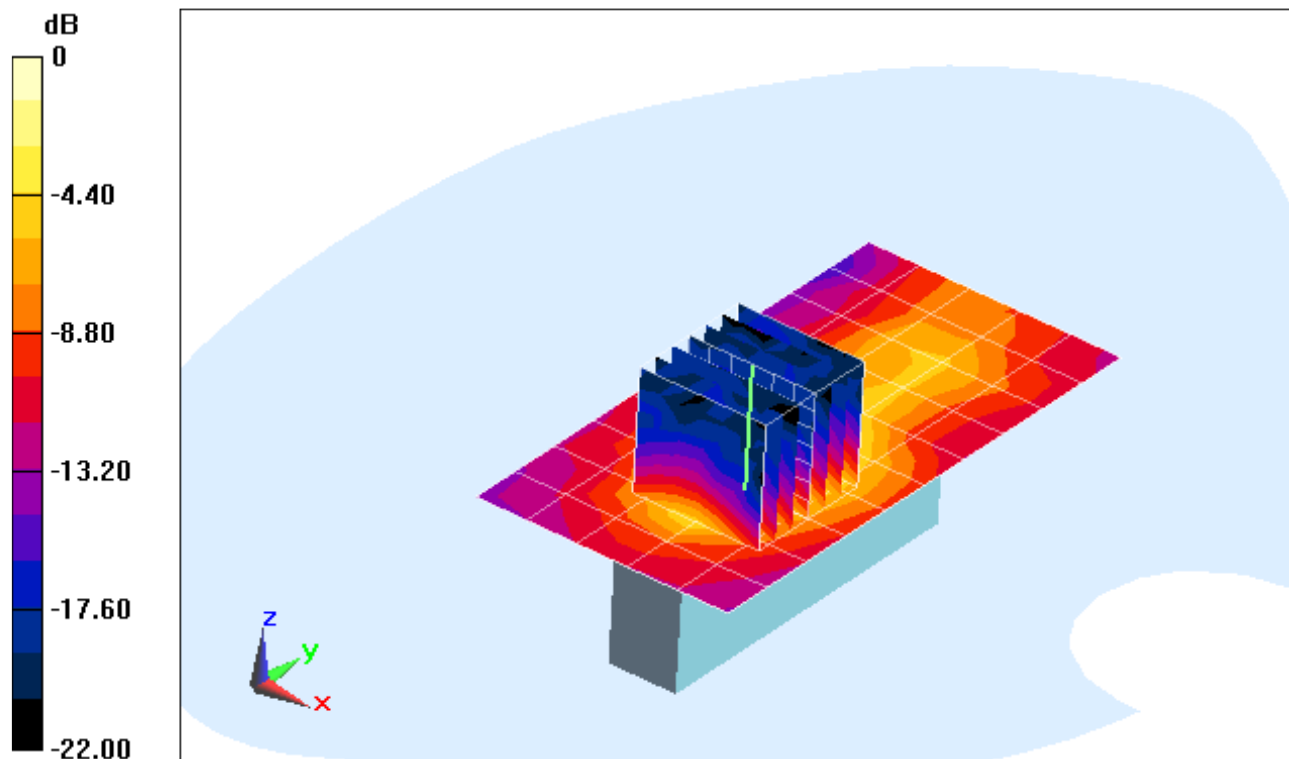

0 dB = 0.794 mW/g = -2.00 dB mW/g

PCTEST ENGINEERING LABORATORY, INC.

DUT: V8YFWA1FU38000W; Type:USB Dongle; Serial: AWB 1

Communication System: WIMAX - 5 MHz; Frequency: 3652.5 MHz;Duty Cycle: 1:2.7

Medium: 3700 Body Medium parameters used (interpolated):

$f = 3652.5$ MHz; $\sigma = 3.575$ mho/m; $\epsilon_r = 53.239$; $\rho = 1000$ kg/m³

Phantom section: Flat Section; Space: 0.5 cm

Test Date: 06-13-2012; Ambient Temp: 23.0°C; Tissue Temp: 21.4°C

Probe: EX3DV4 - SN3645; ConvF(6.15, 6.15, 6.15); Calibrated: 10/26/2011;

Sensor-Surface: 2mm (Mechanical Surface Detection)

Electronics: DAE4 Sn1333; Calibrated: 4/12/2012

Phantom: SAM 5.0 front; Type: QD000P40CD; Serial: TP:-1648

Measurement SW: DASY52, Version 52.8 (1);SEMCAD X Version 14.6.5 (6469)

**Mode: WIMAX, Low channel, QPSK, 5 MHz Bandwidth, PUSC
Horizontal Up, Antenna 1**

Area Scan (6x11x1): Measurement grid: dx=12mm, dy=12mm

Zoom Scan (7x7x8)/Cube 0: Measurement grid: dx=5mm, dy=5mm, dz=4mm

Reference Value = 11.153 V/m; Power Drift = -0.08 dB

Peak SAR (extrapolated) = 1.057 mW/g

SAR(1 g) = 0.409 mW/g; SAR(10 g) = 0.182 mW/g

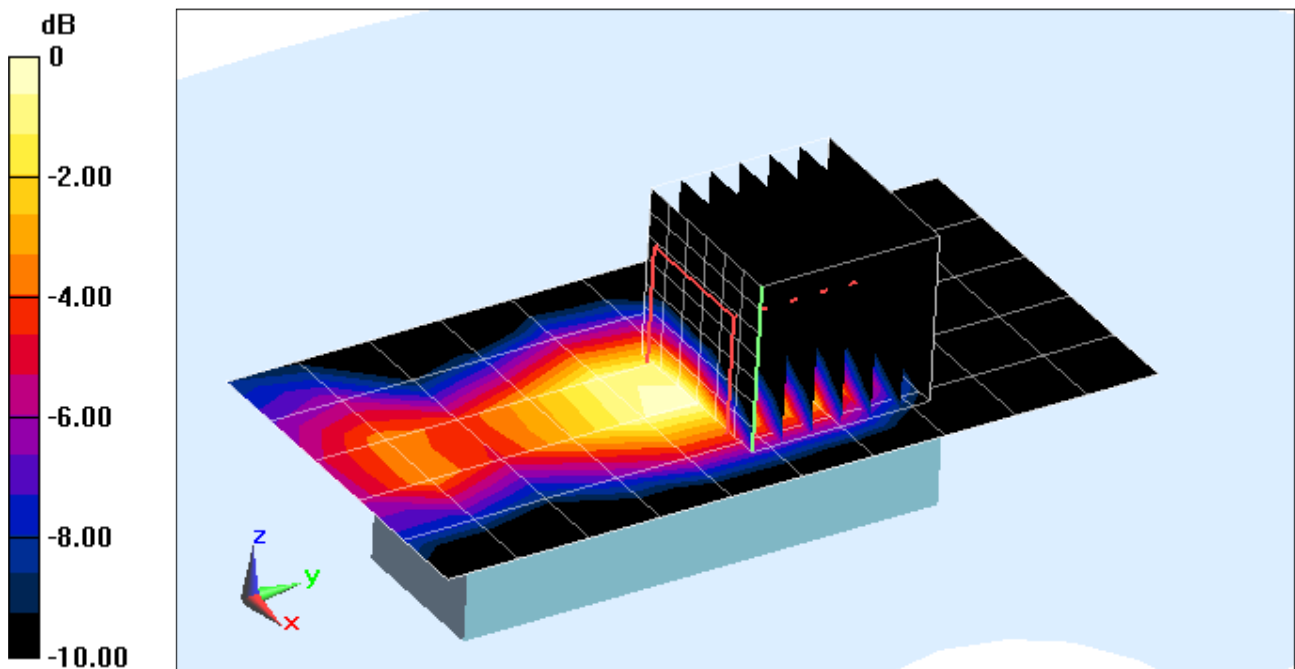

0 dB = 0.665 mW/g = -3.54 dB mW/g

PCTEST ENGINEERING LABORATORY, INC.

DUT: V8YFWA1FU38000W; Type: USB Dongle; Serial: AWB 1

Communication System: WIMAX 3.7 -10 MHz; Frequency: 3662.5 MHz; Duty Cycle: 1:3.2

Medium: 3700 Body Medium parameters used (interpolated):

$f = 3662.5$ MHz; $\sigma = 3.591$ mho/m; $\epsilon_r = 53.224$; $\rho = 1000$ kg/m³

Phantom section: Flat Section; Space: 0.5 cm

Test Date: 06-13-2012; Ambient Temp: 23.0°C; Tissue Temp: 21.4°C

Probe: EX3DV4 - SN3645; ConvF(6.15, 6.15, 6.15); Calibrated: 10/26/2011;

Sensor-Surface: 2mm (Mechanical Surface Detection)

Electronics: DAE4 Sn1333; Calibrated: 4/12/2012

Phantom: SAM 5.0 front; Type: QD000P40CD; Serial: TP:-1648

Measurement SW: DASY52, Version 52.8 (1); SEMCAD X Version 14.6.5 (6469)

**Mode: WIMAX, Low channel, QPSK, 10 MHz Bandwidth, PUSC
Horizontal Up, Antenna 1**

Area Scan (6x11x1): Measurement grid: dx=12mm, dy=12mm

Zoom Scan (7x7x8)/Cube 0: Measurement grid: dx=5mm, dy=5mm, dz=4mm

Reference Value = 9.793 V/m; Power Drift = -0.023 dB

Peak SAR (extrapolated) = 0.995 mW/g

SAR(1 g) = 0.379 mW/g; SAR(10 g) = 0.167 mW/g

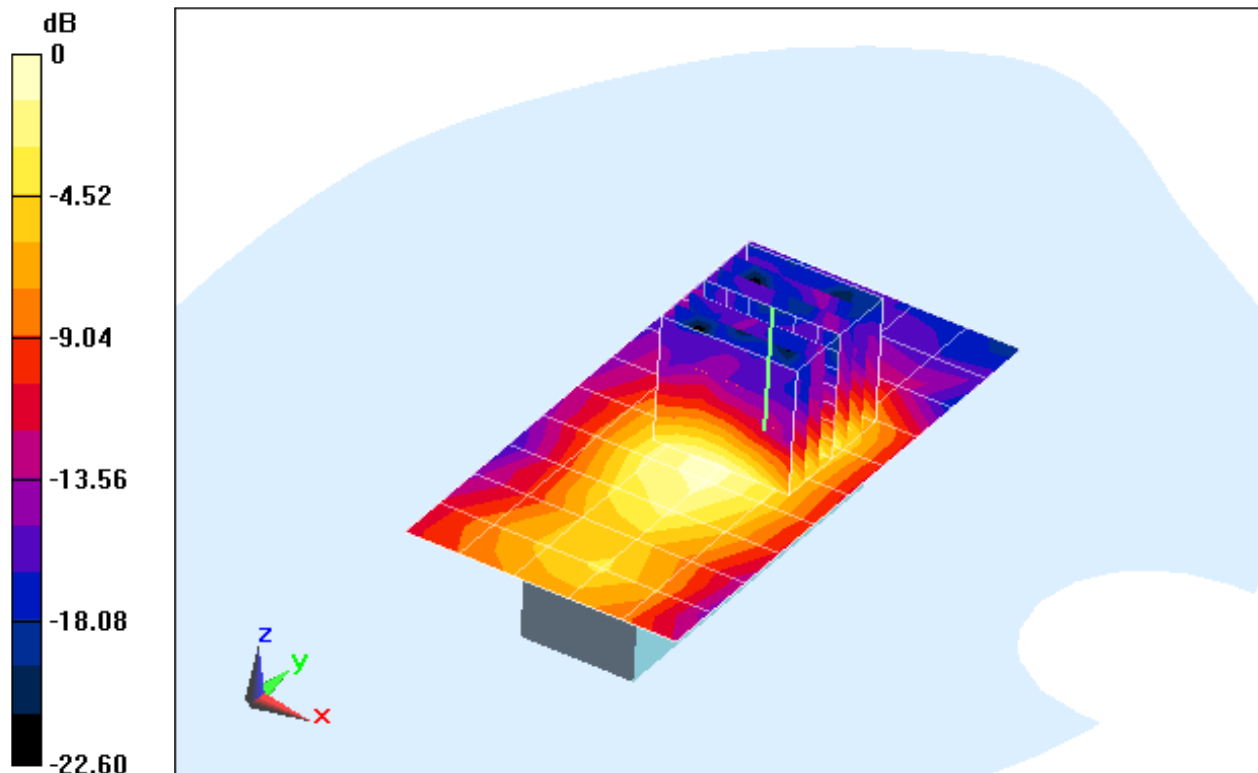

0 dB = 0.610 mW/g = -4.29 dB mW/g

PCTEST ENGINEERING LABORATORY, INC.

DUT: V8YFWA1FU38000W; Type: USB Dongle; Serial: AWB 1

Communication System: WIMAX - 5 MHz; Frequency: 3652.5 MHz; Duty Cycle: 1:2.7

Medium: 3700 Body Medium parameters used (interpolated):

$f = 3652.5$ MHz; $\sigma = 3.575$ mho/m; $\epsilon_r = 53.239$; $\rho = 1000$ kg/m³

Phantom section: Flat Section; Space: 0.5 cm

Test Date: 06-13-2012; Ambient Temp: 23.0°C; Tissue Temp: 21.4°C

Probe: EX3DV4 - SN3645; ConvF(6.15, 6.15, 6.15); Calibrated: 10/26/2011;

Sensor-Surface: 2mm (Mechanical Surface Detection)

Electronics: DAE4 Sn1333; Calibrated: 4/12/2012

Phantom: SAM 5.0 front; Type: QD000P40CD; Serial: TP:-1648

Measurement SW: DASY52, Version 52.8 (1); SEMCAD X Version 14.6.5 (6469)

**Mode: WIMAX, Low channel, QPSK, 5 MHz Bandwidth, PUSC
Horizontal Down, Antenna 1**

Scan (6x11x1): Measurement grid: dx=12mm, dy=12mm

Zoom Scan (7x7x8)/Cube 0: Measurement grid: dx=5mm, dy=5mm, dz=4mm

Reference Value = 13.723 V/m; Power Drift = 0.00 dB

Peak SAR (extrapolated) = 1.650 mW/g

SAR(1 g) = 0.643 mW/g; SAR(10 g) = 0.268 mW/g

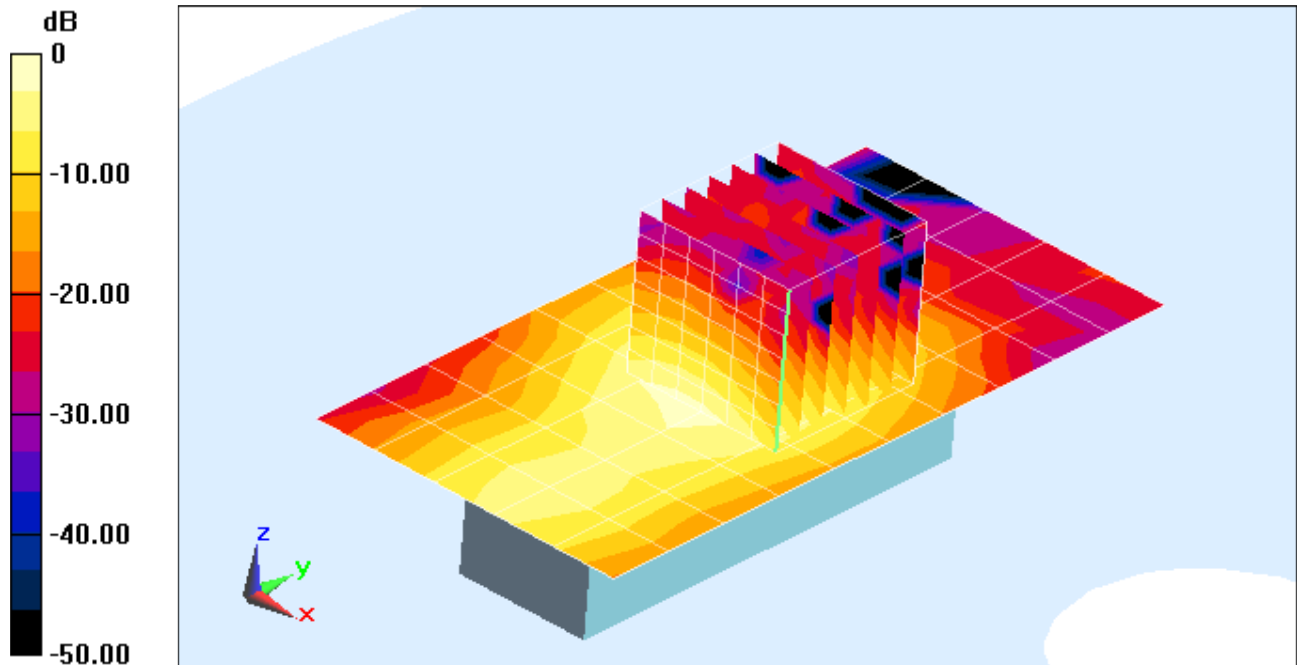

0 dB = 0.944 mW/g = -0.50 dB mW/g

PCTEST ENGINEERING LABORATORY, INC.

DUT: V8YFWA1FU38000W; Type: USB Dongle; Serial: AWB 1

Communication System: WIMAX 3.7 -10 MHz; Frequency: 3662.5 MHz; Duty Cycle: 1:3.2

Medium: 3700 Body Medium parameters used (interpolated):

$f = 3662.5$ MHz; $\sigma = 3.591$ mho/m; $\epsilon_r = 53.224$; $\rho = 1000$ kg/m³

Phantom section: Flat Section; Space: 0.5 cm

Test Date: 06-13-2012; Ambient Temp: 23.0°C; Tissue Temp: 21.4°C

Probe: EX3DV4 - SN3645; ConvF(6.15, 6.15, 6.15); Calibrated: 10/26/2011;

Sensor-Surface: 2mm (Mechanical Surface Detection)

Electronics: DAE4 Sn1333; Calibrated: 4/12/2012

Phantom: SAM 5.0 front; Type: QD000P40CD; Serial: TP:-1648

Measurement SW: DASY52, Version 52.8 (1); SEMCAD X Version 14.6.5 (6469)

**Mode: WIMAX, Low channel, QPSK, 10 MHz Bandwidth, PUSC
Horizontal Down, Antenna 1**

Area Scan (6x11x1): Measurement grid: dx=12mm, dy=12mm

Zoom Scan (7x7x8)/Cube 0: Measurement grid: dx=5mm, dy=5mm, dz=4mm

Reference Value = 12.427 V/m; Power Drift = -0.02 dB

Peak SAR (extrapolated) = 1.380 mW/g

SAR(1 g) = 0.536 mW/g; SAR(10 g) = 0.223 mW/g

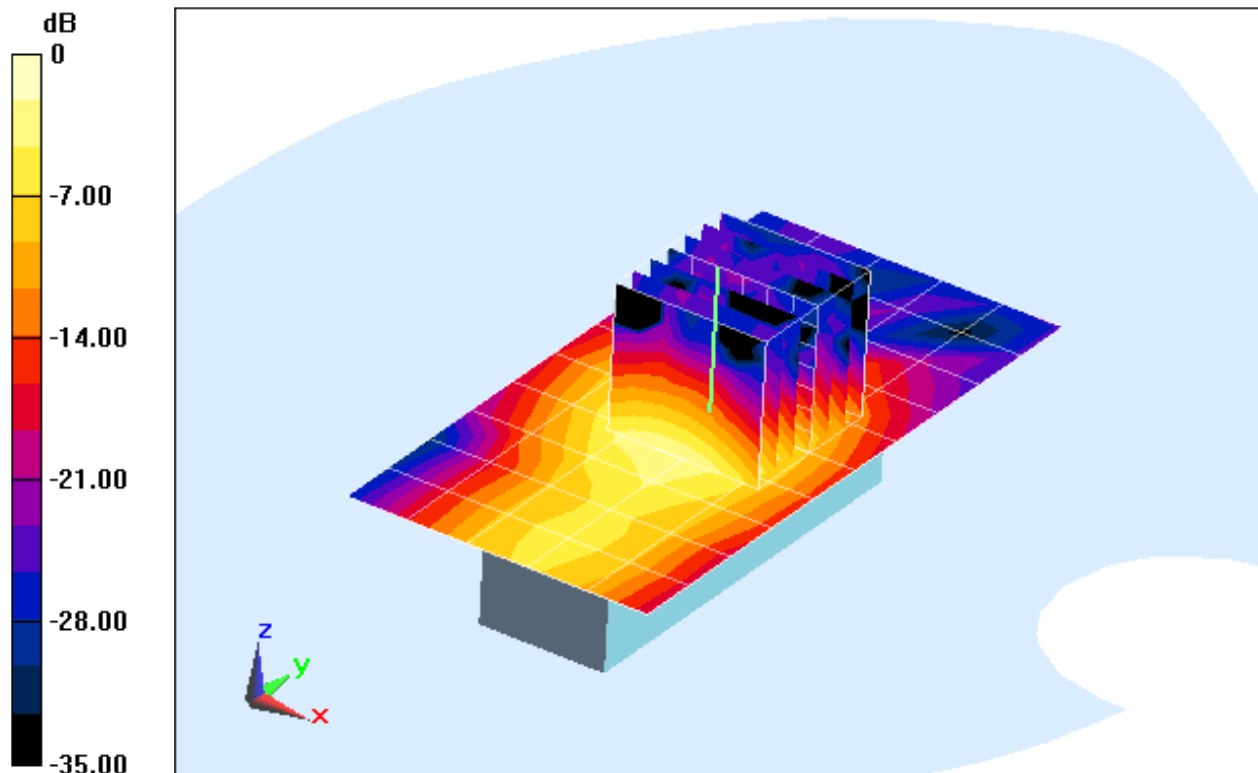

0 dB = 0.903 mW/g = -0.89 dB mW/g

PCTEST ENGINEERING LABORATORY, INC.

DUT: V8YFWA1FU38000W; Type: USB Dongle; Serial: AWB 1

Communication System: WIMAX - 5 MHz; Frequency: 3652.5 MHz; Duty Cycle: 1:2.7

Medium: 3700 Body Medium parameters used (interpolated):

$f = 3652.5 \text{ MHz}$; $\sigma = 3.575 \text{ mho/m}$; $\epsilon_r = 53.239$; $\rho = 1000 \text{ kg/m}^3$

Phantom section: Flat Section; Space: 0.5 cm

Test Date: 06-13-2012; Ambient Temp: 23.0°C; Tissue Temp: 21.4°C

Probe: EX3DV4 - SN3645; ConvF(6.15, 6.15, 6.15); Calibrated: 10/26/2011;

Sensor-Surface: 2mm (Mechanical Surface Detection)

Electronics: DAE4 Sn1333; Calibrated: 4/12/2012

Phantom: SAM 5.0 front; Type: QD000P40CD; Serial: TP:-1648

Measurement SW: DASY52, Version 52.8 (1); SEMCAD X Version 14.6.5 (6469)

**Mode: WIMAX, Low channel, QPSK, 5 MHz Bandwidth, PUSC
Tip, Antenna 1**

Area Scan (6x6x1): Measurement grid: dx=12mm, dy=12mm

Zoom Scan (7x7x8)/Cube 0: Measurement grid: dx=5mm, dy=5mm, dz=4mm

Reference Value = 5.462 V/m; Power Drift = 0.12 dB

Peak SAR (extrapolated) = 0.330 mW/g

SAR(1 g) = 0.122 mW/g; SAR(10 g) = 0.052 mW/g

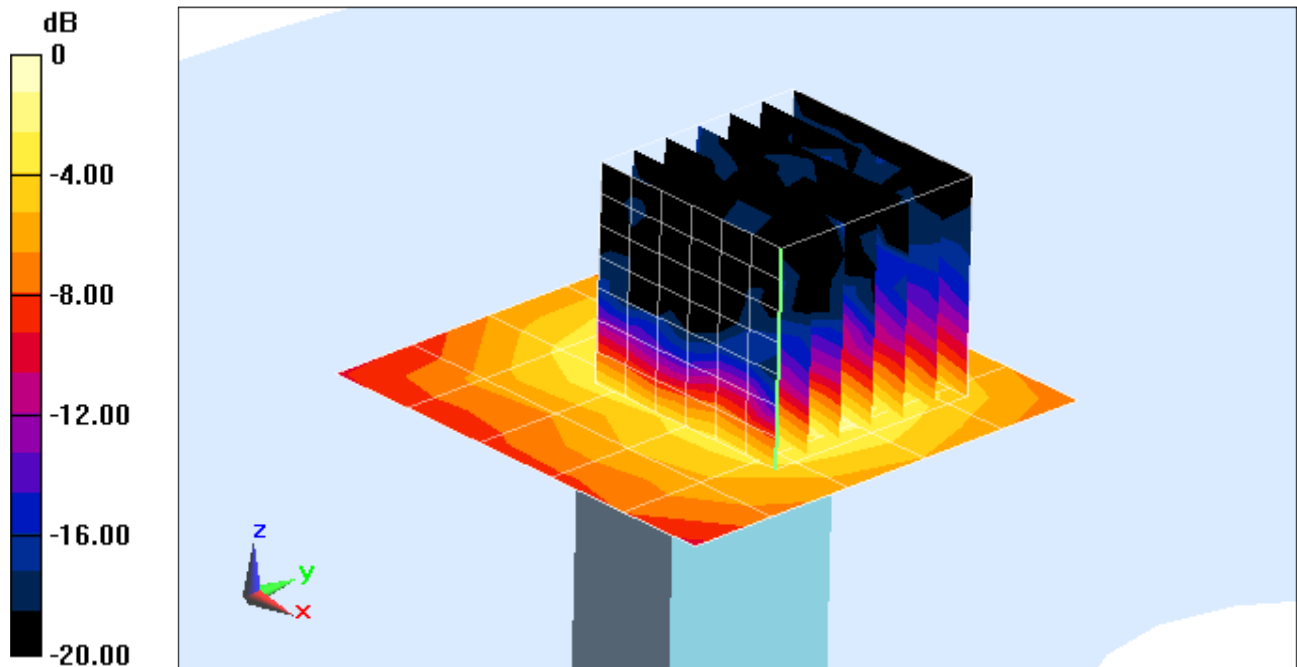

0 dB = 0.206 mW/g = -13.72 dB mW/g

PCTEST ENGINEERING LABORATORY, INC.

DUT: V8YFWA1FU38000W; Type: USB Dongle; Serial: AWB 1

Communication System: WIMAX 3.7 -10 MHz; Frequency: 3662.5 MHz; Duty Cycle: 1:3.2

Medium: 3700 Body Medium parameters used (interpolated):

$f = 3662.5$ MHz; $\sigma = 3.591$ mho/m; $\epsilon_r = 53.224$; $\rho = 1000$ kg/m³

Phantom section: Flat Section; Space: 0.5 cm

Test Date: 06-13-2012; Ambient Temp: 23.0°C; Tissue Temp: 21.4°C

Probe: EX3DV4 - SN3645; ConvF(6.15, 6.15, 6.15); Calibrated: 10/26/2011;

Sensor-Surface: 2mm (Mechanical Surface Detection)

Electronics: DAE4 Sn1333; Calibrated: 4/12/2012

Phantom: SAM 5.0 front; Type: QD000P40CD; Serial: TP:-1648

Measurement SW: DASY52, Version 52.8 (1); SEMCAD X Version 14.6.5 (6469)

**Mode: WIMAX, Mid channel, QPSK, 10 MHz Bandwidth, PUSC
Tip, Antenna 1**

Area Scan (6x6x1): Measurement grid: dx=12mm, dy=12mm

Zoom Scan (7x7x8)/Cube 0: Measurement grid: dx=5mm, dy=5mm, dz=4mm

Reference Value = 4.772 V/m; Power Drift = 0.04 dB

Peak SAR (extrapolated) = 0.242 mW/g

SAR(1 g) = 0.089 mW/g; SAR(10 g) = 0.037 mW/g

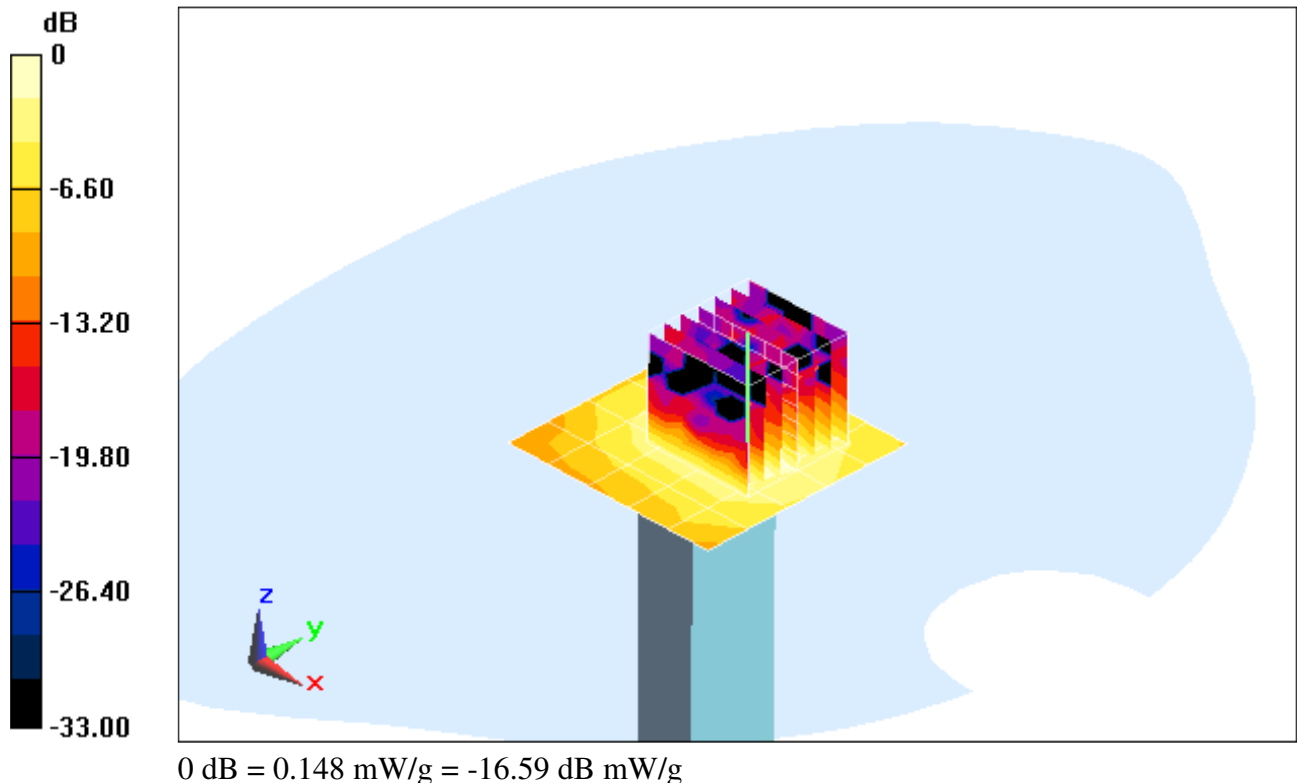

PCTEST ENGINEERING LABORATORY, INC.

DUT: V8YFWA1FU38000W; Type:USB Dongle; Serial: AWB 1

Communication System: WIMAX - 5 MHz; Frequency: 3652.5 MHz;Duty Cycle: 1:2.7

Medium: 3700 Body Medium parameters used (interpolated):

$f = 3652.5 \text{ MHz}$; $\sigma = 3.575 \text{ mho/m}$; $\epsilon_r = 53.239$; $\rho = 1000 \text{ kg/m}^3$

Phantom section: Flat Section; Space: 0.5 cm

Test Date: 06-13-2012; Ambient Temp: 23.0°C; Tissue Temp: 21.4°C

Probe: EX3DV4 - SN3645; ConvF(6.15, 6.15, 6.15); Calibrated: 10/26/2011;

Sensor-Surface: 2mm (Mechanical Surface Detection)

Electronics: DAE4 Sn1333; Calibrated: 4/12/2012

Phantom: SAM 5.0 front; Type: QD000P40CD; Serial: TP:-1648

Measurement SW: DASY52, Version 52.8 (1);SEMCAD X Version 14.6.5 (6469)

**Mode: WIMAX, Low channel, QPSK, 5 MHz Bandwidth, PUSC
Vertical Front, Antenna 1**

Area Scan (6x11x1): Measurement grid: dx=12mm, dy=12mm

Zoom Scan (7x7x8)/Cube 0: Measurement grid: dx=5mm, dy=5mm, dz=4mm

Reference Value = 14.321 V/m; Power Drift = -0.04 dB

Peak SAR (extrapolated) = 1.729 mW/g

SAR(1 g) = 0.670 mW/g; SAR(10 g) = 0.267 mW/g

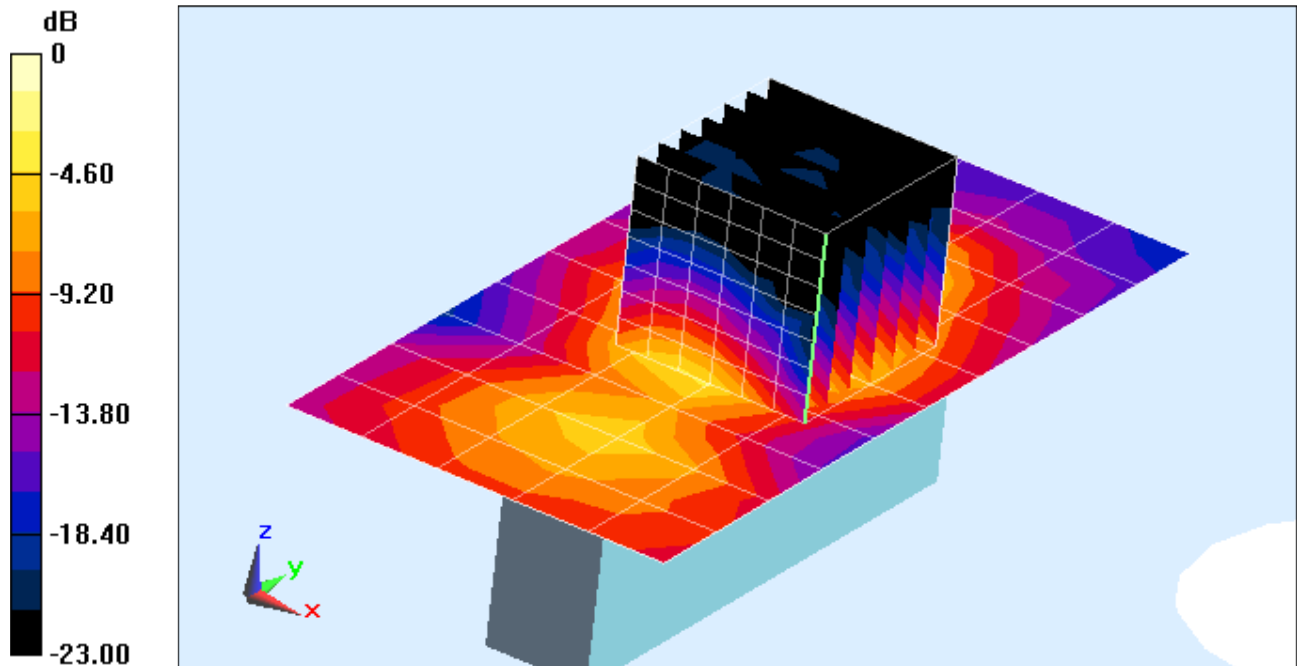

0 dB = 1.11 mW/g = 0.91 dB mW/g

PCTEST ENGINEERING LABORATORY, INC.

DUT: V8YFWA1FU38000W; Type: USB Dongle; Serial: AWB 1

Communication System: WIMAX 3.7 -10 MHz; Frequency: 3662.5 MHz; Duty Cycle: 1:3.2

Medium: 3700 Body Medium parameters used (interpolated):

$f = 3662.5$ MHz; $\sigma = 3.591$ mho/m; $\epsilon_r = 53.224$; $\rho = 1000$ kg/m³

Phantom section: Flat Section; Space: 0.5 cm

Test Date: 06-13-2012; Ambient Temp: 23.0°C; Tissue Temp: 21.4°C

Probe: EX3DV4 - SN3645; ConvF(6.15, 6.15, 6.15); Calibrated: 10/26/2011;

Sensor-Surface: 2mm (Mechanical Surface Detection)

Electronics: DAE4 Sn1333; Calibrated: 4/12/2012

Phantom: SAM 5.0 front; Type: QD000P40CD; Serial: TP:-1648

Measurement SW: DASY52, Version 52.8 (1); SEMCAD X Version 14.6.5 (6469)

**Mode: WIMAX, Mid. Channel, QPSK 10 MHz Bandwidth, PUSC
Vertical Front, Antenna 1**

Area Scan (6x11x1): Measurement grid: dx=12mm, dy=12mm

Zoom Scan (7x7x8)/Cube 0: Measurement grid: dx=5mm, dy=5mm, dz=4mm

Reference Value = 10.271 V/m; Power Drift = 0.08 dB

Peak SAR (extrapolated) = 0.882 mW/g

SAR(1 g) = 0.333 mW/g; SAR(10 g) = 0.132 mW/g

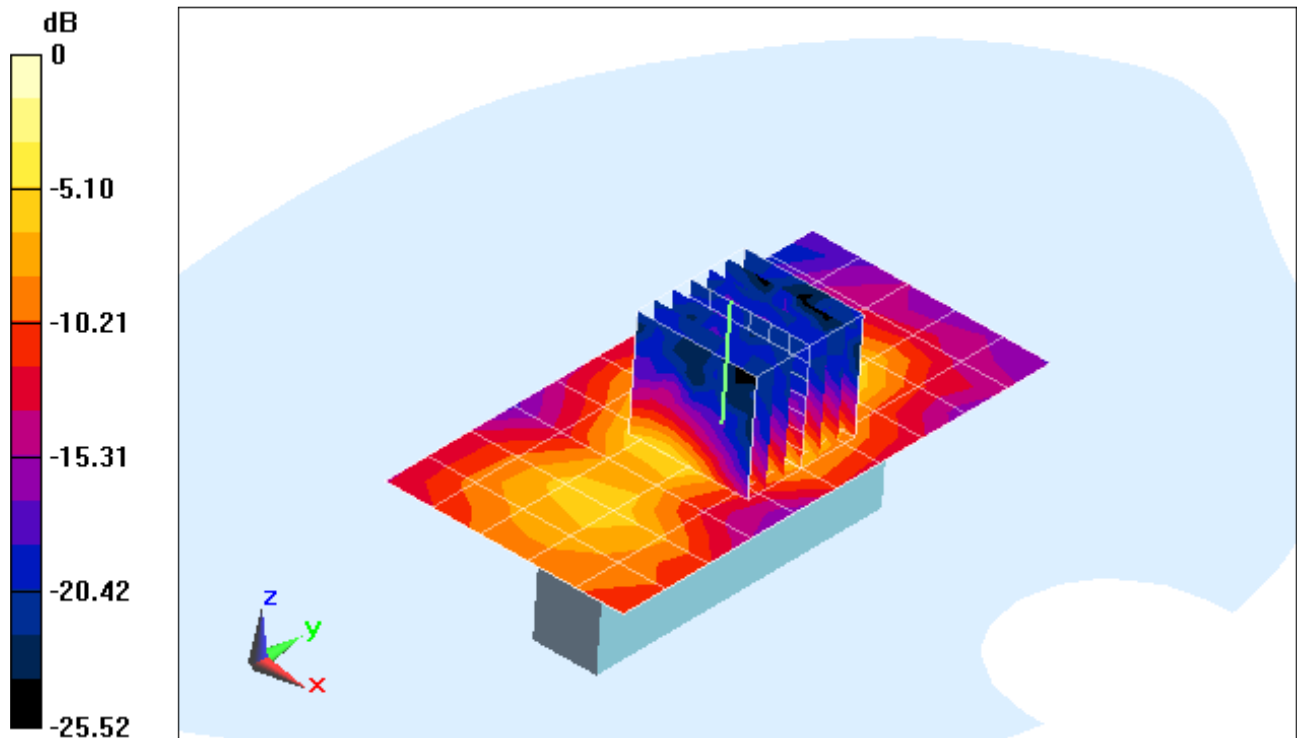

0 dB = 0.570 mW/g = -4.88 dB mW/g

PCTEST ENGINEERING LABORATORY, INC.

DUT: V8YFWA1FU38000W; Type: USB Dongle; Serial: AWB 1

Communication System: wimax 3.7- 5 mhz; Frequency: 3652.5 MHz;Duty Cycle: 1:2.7

Medium: 3700 Body Medium parameters used (interpolated):

$f = 3652.5$ MHz; $\sigma = 3.575$ mho/m; $\epsilon_r = 53.239$; $\rho = 1000$ kg/m³

Phantom section: Flat Section; Space: 0.5 cm

Test Date: 06-13-2012; Ambient Temp: 23.0°C; Tissue Temp: 21.4°C

Probe: EX3DV4 - SN3645; ConvF(6.15, 6.15, 6.15); Calibrated: 10/26/2011;

Sensor-Surface: 2mm (Mechanical Surface Detection)

Electronics: DAE4 Sn1333; Calibrated: 4/12/2012

Phantom: SAM 5.0 front; Type: QD000P40CD; Serial: TP:-1648

Measurement SW: DASY52, Version 52.8 (1);SEMCAD X Version 14.6.5 (6469)

**Mode: WIMAX, Low channel, QPSK, 5 MHz Bandwidth, PUSC
Vertical Back, Antenna 1**

Area Scan (6x11x1): Measurement grid: dx=12mm, dy=12mm

Zoom Scan (7x7x8)/Cube 0: Measurement grid: dx=5mm, dy=5mm, dz=4mm

Reference Value = 6.785 V/m; Power Drift = -0.05 dB

Peak SAR (extrapolated) = 0.375 mW/g

SAR(1 g) = 0.148 mW/g; SAR(10 g) = 0.070 mW/g

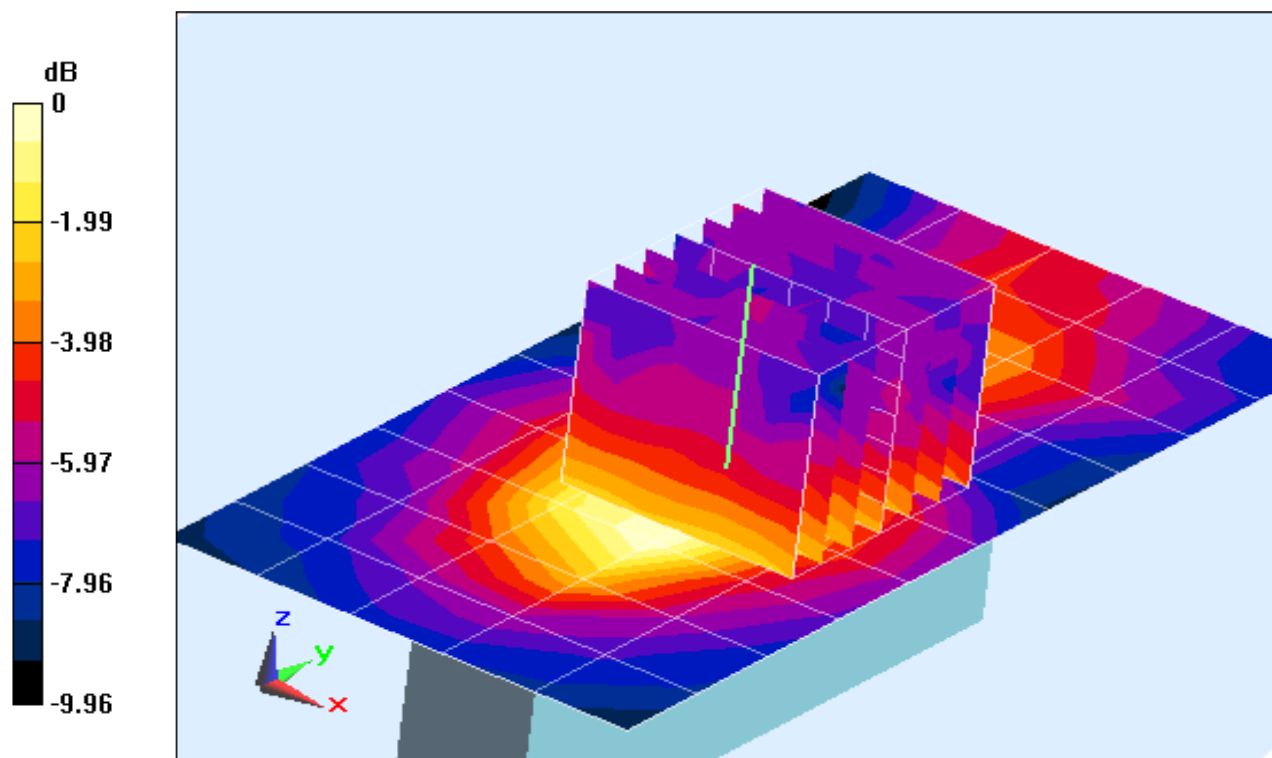

0 dB = 0.232 mW/g = -12.67 dB mW/g

PCTEST ENGINEERING LABORATORY, INC.

DUT: V8YFWA1FU38000W; Type: USB Dongle; Serial: AWB 1

Communication System: WIMAX 3.7 -10 MHz; Frequency: 3662.5 MHz; Duty Cycle: 1:3.2

Medium: 3700 Body Medium parameters used (interpolated):

$f = 3662.5$ MHz; $\sigma = 3.591$ mho/m; $\epsilon_r = 53.224$; $\rho = 1000$ kg/m³

Phantom section: Flat Section; Space: 0.5 cm

Test Date: 06-13-2012; Ambient Temp: 23.0°C; Tissue Temp: 21.4°C

Probe: EX3DV4 - SN3645; ConvF(6.15, 6.15, 6.15); Calibrated: 10/26/2011;

Sensor-Surface: 2mm (Mechanical Surface Detection)

Electronics: DAE4 Sn1333; Calibrated: 4/12/2012

Phantom: SAM 5.0 front; Type: QD000P40CD; Serial: TP:-1648

Measurement SW: DASY52, Version 52.8 (1); SEMCAD X Version 14.6.5 (6469)

**Mode: WIMAX, Mid. Channel, QPSK, 10 MHz Bandwidth, PUSC
Vertical Back, Antenna 1**

Area Scan (6x11x1): Measurement grid: dx=12mm, dy=12mm

Zoom Scan (7x7x8)/Cube 0: Measurement grid: dx=5mm, dy=5mm, dz=4mm

Reference Value = 6.527 V/m; Power Drift = 0.03 dB

Peak SAR (extrapolated) = 0.357 mW/g

SAR(1 g) = 0.140 mW/g; SAR(10 g) = 0.064 mW/g

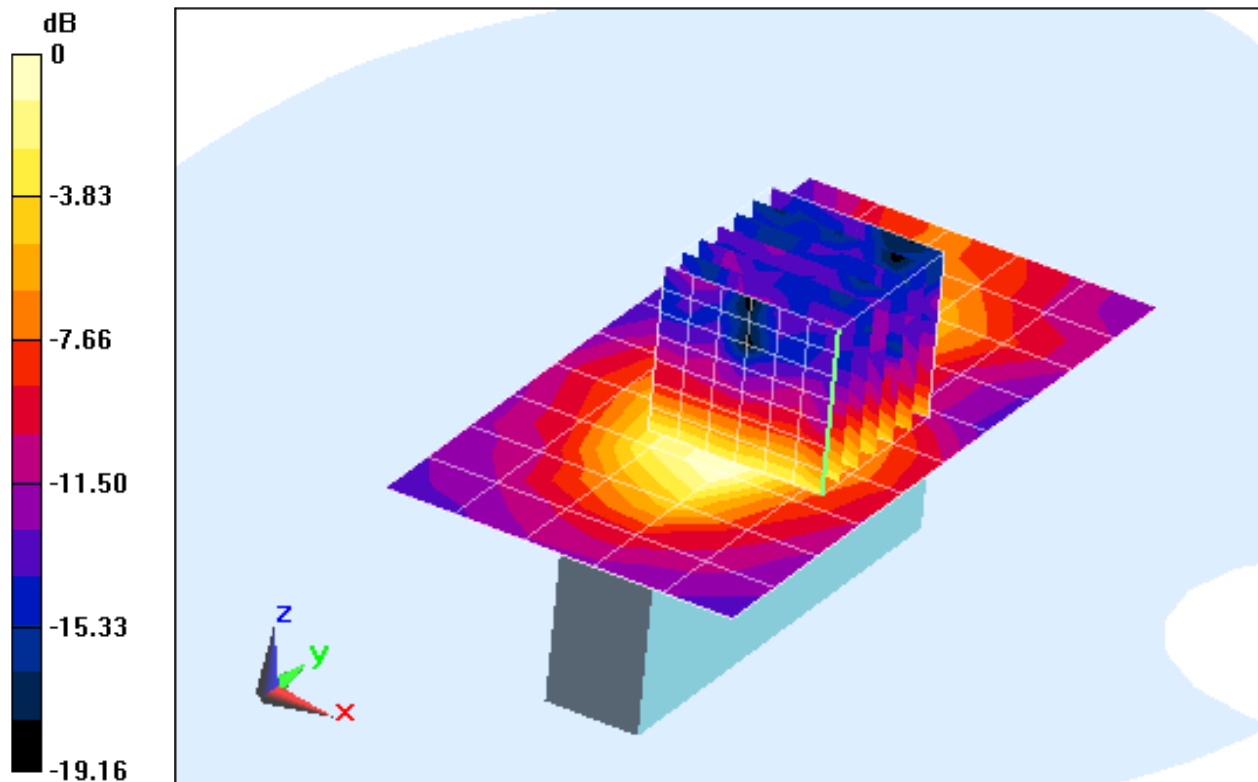

0 dB = 0.890 mW/g = -1.01 dB mW/g

APPENDIX B: DIPOLE VALIDATION

PCTEST ENGINEERING LABORATORY, INC.

DUT: Dipole 3700 MHz; Type: D3700V2; Serial: 1002

Communication System: CW; Frequency: 3700 MHz; Duty Cycle: 1:1

Medium: 3700 Body Medium parameters used (interpolated):

$f = 3700$ MHz; $\sigma = 3.646$ mho/m; $\epsilon_r = 53.183$; $\rho = 1000$ kg/m³

Phantom section: Flat Section; Space: 1.0 cm

Test Date: 06-13-2012; Ambient Temp: 23.0°C; Tissue Temp: 21.4°C

Probe: EX3DV4 - SN3645; ConvF(6.15, 6.15, 6.15); Calibrated: 10/26/2011

Sensor-Surface: 2mm (Mechanical Surface Detection)

Electronics: DAE4 Sn1333; Calibrated: 4/12/2012

Phantom: SAM 5.0 front; Type: QD000P40CD; Serial: TP:-1648

Measurement SW: DASY52, Version 52.8 (0); SEMCAD X Version 14.6.5 (6469)

3700 MHz System Verification

Area Scan (6x6x1): Measurement grid: dx=12mm, dy=12mm

Zoom Scan (7x7x8)/Cube 0: Measurement grid: dx=5mm, dy=5mm, dz=4mm

Input Power = 20.0 dBm (100mW)

SAR(1 g) = 6.41 mW/g; SAR(10 g) = 2.29 mW/g

Deviation = 4.40 %

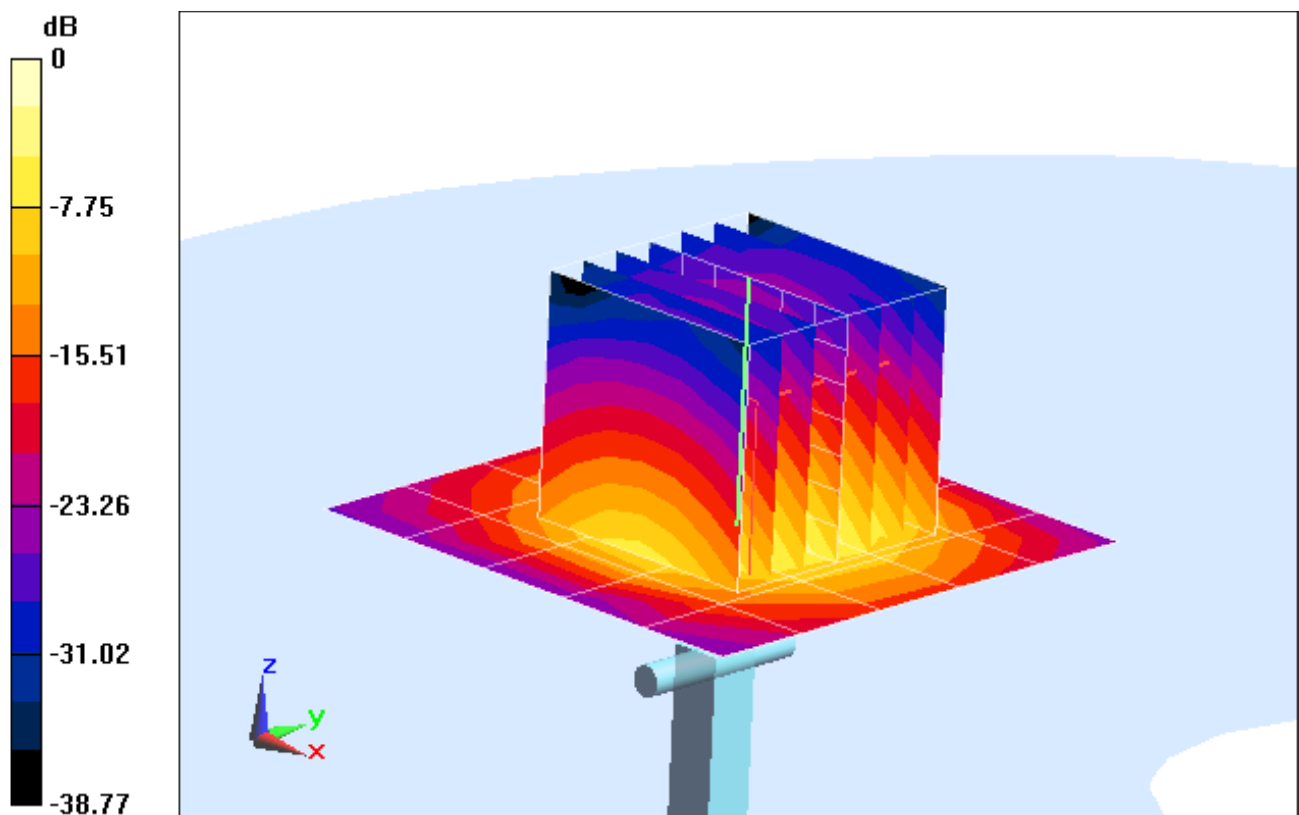

0 dB = 11.320mW/g = 21.08 dB mW/g

PCTEST ENGINEERING LABORATORY, INC.

DUT: Dipole 3700 MHz; Type: D3700V2; Serial: 1002

Communication System: CW; Frequency: 3700 MHz; Duty Cycle: 1:1

Medium: 3700 Body Medium parameters used (interpolated):

$f = 3700 \text{ MHz}$; $\sigma = 3.646 \text{ mho/m}$; $\epsilon_r = 53.183$; $\rho = 1000 \text{ kg/m}^3$

Phantom section: Flat Section; Space: 1.0 cm

Test Date: 06-13-2012; Ambient Temp: 23.0°C; Tissue Temp: 21.4°C

Probe: EX3DV4 - SN3645; ConvF(6.15, 6.15, 6.15); Calibrated: 10/26/2011

Sensor-Surface: 2mm (Mechanical Surface Detection)

Electronics: DAE4 Sn1333; Calibrated: 4/12/2012

Phantom: SAM 5.0 front; Type: QD000P40CD; Serial: TP:-1648

Measurement SW: DASY52, Version 52.8 (0); SEMCAD X Version 14.6.5 (6469)

3700 MHz System Verification

Area Scan (6x6x1): Measurement grid: dx=12mm, dy=12mm

Zoom Scan (7x7x8)/Cube 0: Measurement grid: dx=5mm, dy=5mm, dz=4mm

Input Power = 20.0 dBm (100mW)

SAR(1 g) = 6.41 mW/g; SAR(10 g) = 2.29 mW/g

Deviation = 4.40 %

