



A D T

FCC SUPPLEMENTARY TEST REPORT

REPORT NO.: RF980519H05C

MODEL NO.: WG6205-1U

RECEIVED: July 29, 2009

TESTED: Aug. 21, 2009

ISSUED: Nov. 25, 2009

APPLICANT: Accton Wireless Broadband Corp.

ADDRESS: 3F, No. 1 Creation Rd. III, Science-based Industrial
Park Hsinchu 30077, Taiwan, R.O.C.

ISSUED BY: Bureau Veritas Consumer Products Services (H.K.)
Ltd., Taoyuan Branch Hsin Chu Laboratory

ADDRESS: No. 81-1, Lu Liao Keng, 9th Ling, Wu Lung Tsuen,
Chiung Lin Hsiang, Hsin Chu Hsien 307, Taiwan

This test report consists of 32 pages in total. It may be duplicated completely for legal use with the approval of the applicant. It should not be reproduced except in full, without the written approval of our laboratory. The client should not use it to claim product endorsement by TAF or any government agencies. The test results in the report only apply to the tested sample.





TABLE OF CONTENTS

1.	CERTIFICATION.....	3
2.	SUMMARY OF TEST RESULTS	4
2.1	MEASUREMENT UNCERTAINTY	4
3.	GENERAL INFORMATION.....	5
3.1	GENERAL DESCRIPTION OF EUT	5
3.2	DESCRIPTION OF TEST MODES	8
3.2.1	TEST MODE APPLICABILITY AND TESTED CHANNEL DETAIL.....	9
3.3	GENERAL DESCRIPTION OF APPLIED STANDARDS.....	10
3.4	DESCRIPTION OF SUPPORT UNITS.....	11
3.5	CONFIGURATION OF SYSTEM UNDER TEST.....	12
4.	TEST TYPES AND RESULTS	13
4.1	CONDUCTED EMISSION MEASUREMENT.....	13
4.1.1	LIMITS OF CONDUCTED EMISSION MEASUREMENT	13
4.1.2	TEST INSTRUMENTS.....	13
4.1.3	TEST PROCEDURES	14
4.1.4	DEVIATION FROM TEST STANDARD	14
4.1.5	TEST SETUP.....	14
4.1.6	EUT OPERATING CONDITIONS.....	15
4.1.7	TEST RESULTS	16
4.2	RADIATED EMISSION MEASUREMENT.....	18
4.2.1	LIMITS OF RADIATED EMISSION MEASUREMENT	18
4.2.2	TEST INSTRUMENTS.....	19
4.2.3	TEST PROCEDURES	21
4.2.4	DEVIATION FROM TEST STANDARD	21
4.2.5	TEST SETUP	22
4.2.6	EUT OPERATING CONDITIONS.....	22
4.2.7	TEST RESULTS	23
5.	INFORMATION ON THE TESTING LABORATORIES.....	31
6.	APPENDIX - A MODIFICATIONS RECORDERS FOR ENGINEERING CHANGES TO THE EUT BY THE LAB.....	32



A D T

1. CERTIFICATION

PRODUCT : Draft 11n Wireless 3G Broadband Router
BRAND : AWB
MODEL NO.: WG6205-1U
APPLICANT : Accton Wireless Broadband Corp.
TESTED : Aug. 21, 2009
TEST SAMPLE : R&D SAMPLE
STANDARDS : FCC Part 15, Subpart C (Section 15.247),
ANSI C63.4-2003

The above equipment (Model: WG6205-1U) has been tested by **Bureau Veritas Consumer Products Services (H.K.) Ltd., Taoyuan Branch**, and found compliance with the requirement of the above standards. The test record, data evaluation & Equipment Under Test (EUT) configurations represented herein are true and accurate accounts of the measurements of the sample's EMC characteristics under the conditions specified in this report.

PREPARED BY :  , **DATE:** Nov. 25, 2009
(Sunny Wen, Specialist)

TECHNICAL ACCEPTANCE :  , **DATE:** Nov. 25, 2009
Responsible for RF (Hank Chung, Deputy Manager)

APPROVED BY :  , **DATE:** Nov. 25, 2009
(May Chen, Deputy Manager)



2. SUMMARY OF TEST RESULTS

The EUT has been tested according to the following specifications:

APPLIED STANDARD: FCC Part 15, Subpart C			
STANDARD SECTION	TEST TYPE AND LIMIT	RESULT	REMARK
15.207	AC Power Conducted Emission	PASS	Meet the requirement of limit. Minimum passing margin is -0.45dB at 0.462MHz
15.247(d)	Transmitter Radiated Emissions Limit: Table 15.209	PASS	Meet the requirement of limit. Minimum passing margin is -0.6dB at 2483.5MHz.

NOTE:

1. This report is prepared for FCC class II permissive change. Only conducted emission and radiated emission were presented in this test report.

2.1 MEASUREMENT UNCERTAINTY

Where relevant, the following measurement uncertainty levels have been estimated for tests performed on the EUT as specified in CISPR 16-4-2:

This uncertainty represents an expanded uncertainty expressed at approximately the 95% confidence level using a coverage factor of k=2.

Measurement	Value
Conducted emissions	2.45 dB
Radiated emissions (30MHz-1GHz)	3.83 dB
Radiated emissions (1GHz -18GHz)	2.49 dB
Radiated emissions (18GHz -40GHz)	2.70 dB



3. GENERAL INFORMATION

3.1 GENERAL DESCRIPTION OF EUT

PRODUCT	Draft 11n Wireless 3G Broadband Router
MODEL NO.	WG6205-1U
FCC ID	V8YFIU176205000W
POWER SUPPLY	DC 5V from switching adapter
MODULATION TYPE	CCK, DQPSK, DBPSK for DSSS 64QAM, 16QAM, QPSK, BPSK for OFDM
MODULATION TECHNOLOGY	DSSS, OFDM
TRANSFER RATE	802.11b: 11/ 5.5/ 2/ 1Mbps 802.11g: 54/ 48/ 36/ 24/ 18/ 12/ 9/ 6Mbps Draft 802.11n (20MHz, 400ns GI): 144.4 / 130 / 115.6 / 86.7 / 72.2 / 65 / 57.8 / 43.3 / 28.9 / 21.7 / 14.4 / 7.2Mbps Draft 802.11n (40MHz, 400ns GI): 300 / 270 / 240 / 180 / 150 / 135 / 120 / 90 / 60 / 45 / 30 / 15Mbps
FREQUENCY RANGE	2412MHz ~ 2462MHz
NUMBER OF CHANNEL	11 for 802.11b, 802.11g, draft 802.11n (20MHz) 7 for draft 802.11n (40MHz)
MAXIMUM OUTPUT POWER	802.11b: 74.1mW 802.11g: 323.6mW draft 802.11n (20MHz): 399.2mW draft 802.11n (40MHz): 447.9mW
ANTENNA TYPE	Please see note 1
DATA CABLE	USB cable (shielded, 1.3m) for 3G dongle
I/O PORT	WAN port x 1, Ethernet port x 4, USB port for 3G card x 1
ASSOCIATED DEVICES	Adapter x 1



NOTE:

1. This report is prepared for FCC class II permissive change. The difference compared with the Report No.: RF980519H05A design is as the following:

- u Add one USB port for 3G card.
- u Add the product name and model names as below :

Product Name	Draft 11n Wireless 3G Broadband Router	
Brand	Model No.	Difference
AWB	WG6205-1U	1. WAN port x 1, Ethernet port x 4, USB port for 3G card x 1

- u Original Integral antenna change to detachable antenna ,the antenna connector types as below :

No.	Brand	Model	Gain (dBi)	Antenna Type	Connector Type	Frequency range (MHz to MHz)	Diversity Function
1	AWB	120300000013W	2	Omni	Reverse SMA	2400~2500	Yes
2	AWB	120300000013W	2	Omni	Reverse SMA	2400~2500	Yes

2. The EUT could be applied with one 3G card and following three different models could be chosen; therefore emission tests are added for simultaneously transmit between wireless LAN and 3G function. The emission tests have been performed at the worst channel of both WLAN and 3G, and recorded in other report.

Interface	Brand	Model No.	FCC ID
USB port	HUAWEI	E220	QISE220
	Novatel	MCD3000	PKRNVWMCD3000
	Novatel	MC727	PKRNVWMC727

From the above 3G cards, Model No.: **MC727** was the worst case for testing.



3. The EUT must be supplied with a power adapter and as following:

Brand:	N.A.
Model No.:	PSA15-1U
Input power :	AC100-240V, 0.5A, 50-60Hz
Output power :	DC 5V, 2A DC output cable (Unshielded, 1.6m)

4. The EUT was pre-tested in chamber under the following modes:

Test Mode	Description
Mode A	Level-set (Put on tabletop)
Mode B	Tower-set (Wall-mounted)

From the above modes, the radiated emission worse case was found in **Mode A**.

Therefore only the test data of the mode was recorded in this report.

5. The EUT incorporates a MIMO function with draft 802.11n. Physically, the EUT provides two completed transmit and two completed receivers.
6. The EUT is 2 * 2 spatial MIMO without beam forming function. The antenna configuration is two transmitter antenna and two receiver antenna, as there are 2 Omni antennas. Spatial multiplexing modes for simultaneous transmission using 2 antennas, and for simultaneous receiver using 2 antennas. The 11b/g legacy mode is limited to single transmitter only.
7. When the EUT operating in draft 802.11n, the software operation, which is defined by manufacturer, MCS (Modulation and Coding Schemes) from 0 to 15.
8. The EUT complies with draft 802.11n standards and backwards compatible with 802.11b, 802.11g products.
9. The above EUT information was declared by manufacturer and for more detailed features description, please refer to the manufacturer's specifications or user's manual.



3.2 DESCRIPTION OF TEST MODES

Eleven channels are provided for 802.11b, 802.11g, draft 802.11n (20MHz):

CHANNEL	FREQUENCY	CHANNEL	FREQUENCY
1	2412MHz	7	2442MHz
2	2417MHz	8	2447MHz
3	2422MHz	9	2452MHz
4	2427MHz	10	2457MHz
5	2432MHz	11	2462MHz
6	2437MHz		

Seven channels are provided for draft 802.11n (40MHz):

CHANNEL	FREQUENCY	CHANNEL	FREQUENCY
1	2422MHz	5	2442MHz
2	2427MHz	6	2447MHz
3	2432MHz	7	2452MHz
4	2437MHz		



A D T

3.2.1 TEST MODE APPLICABILITY AND TESTED CHANNEL DETAIL

EUT CONFIGURE MODE	APPLICABLE TO				DESCRIPTION
	PLC	RE < 1G	RE ³ 1G	APCM	
-	√	√	√	-	-

Where **PLC:** Power Line Conducted Emission

RE < 1G: Radiated Emission below 1GHz

RE ³ 1G: Radiated Emission above 1GHz

APCM: Antenna Port Conducted Measurement

ANTENNA COMBINATION MODE:

COMBINATION MODE	OPERATION MODE	TX CHAIN(0)	TX CHAIN(1)
A	802.11b	√	
B	802.11b		√
C	802.11g	√	
D	802.11g		√
E	DRAFT 802.11n(20MHz) for MCS 0~7	√	√
F	DRAFT 802.11n(20MHz) for MCS 8~15	√	√
G	DRAFT 802.11n(40MHz) for MCS 0~7	√	√
H	DRAFT 802.11n(40MHz) for MCS 8~15	√	√

Note:

1. The above information was declared by manufacturer and for more detailed features description, please refer to the manufacturer's specifications or user's manual.
2. Antenna 1~2 are Omni antennas.
3. Mode A, E the worst modes, were selected as representative mode for the report.

POWER LINE CONDUCTED EMISSION TEST:

- Pre-Scan has been conducted to determine the worst-case mode from all possible combinations between available modulations, data rates and antenna ports (if EUT with antenna diversity architecture).
- Following channel(s) was (were) selected for the final test as listed below.

MODE	AVAILABLE CHANNEL	TESTED CHANNEL	MODULATION TECHNOLOGY	MODULATION TYPE	DATA RATE (Mbps)	COMBINATION MODE
802.11b	1 to 11	1	DSSS	DBPSK	1	A



RADIATED EMISSION TEST (BELOW 1 GHZ):

Pre-Scan has been conducted to determine the worst-case mode from all possible combinations between available modulations, data rates and antenna ports (if EUT with antenna diversity architecture).

Following channel(s) was (were) selected for the final test as listed below.

MODE	AVAILABLE CHANNEL	TESTED CHANNEL	MODULATION TECHNOLOGY	MODULATION TYPE	DATA RATE (Mbps)	COMBINATION MODE
802.11b	1 to 11	1	DSSS	DBPSK	1	A

RADIATED EMISSION TEST (ABOVE 1 GHZ):

Pre-Scan has been conducted to determine the worst-case mode from all possible combinations between available modulations, data rates and antenna ports (if EUT with antenna diversity architecture).

Following channel(s) was (were) selected for the final test as listed below.

MODE	AVAILABLE CHANNEL	TESTED CHANNEL	MODULATION TECHNOLOGY	MODULATION TYPE	DATA RATE (Mbps)	EUT CONFIGURE MODE
Draft 802.11n (20MHz)	1 to 11	1, 6, 11	OFDM	BPSK	7.2	E

3.3 GENERAL DESCRIPTION OF APPLIED STANDARDS

The EUT is an RF product. According to the specifications of the manufacturer, it must comply with the requirements of the following standards:

FCC Part 15, Subpart C. (15.247)

ANSI C63.4-2003

All test items have been performed and recorded as per the above standards.

NOTE: The EUT is also considered as a kind of computer peripheral, because the connection to computer is necessary for typical use. It has been verified to comply with the requirements of FCC Part 15, Subpart B, Class B (DoC). The test report has been issued separately.



3.4 DESCRIPTION OF SUPPORT UNITS

The EUT has been tested as an independent unit together with other necessary accessories or support units. The following support units or accessories were used to form a representative test configuration during the tests.

NO.	PRODUCT	BRAND	MODEL NO.	SERIAL NO.	FCC ID
1	NOTEBOOK COMPUTER	DELL	PP18L	12252644560	DoC
2	NOTEBOOK COMPUTER	HP	HSTNN-S19C	JP96X-4Y88K-BXXY 8-K27B3-M86FT	DoC
3	USB727 MODEM	Novatel	MC727	NA	PKRNVWMC7 27

NO.	SIGNAL CABLE DESCRIPTION OF THE ABOVE SUPPORT UNITS
1	10m, UTP cable.
2	10m, UTP cable.
3	NA

NOTE: All power cords of the above support units are non shielded (1.8m).

3.5 CONFIGURATION OF SYSTEM UNDER TEST

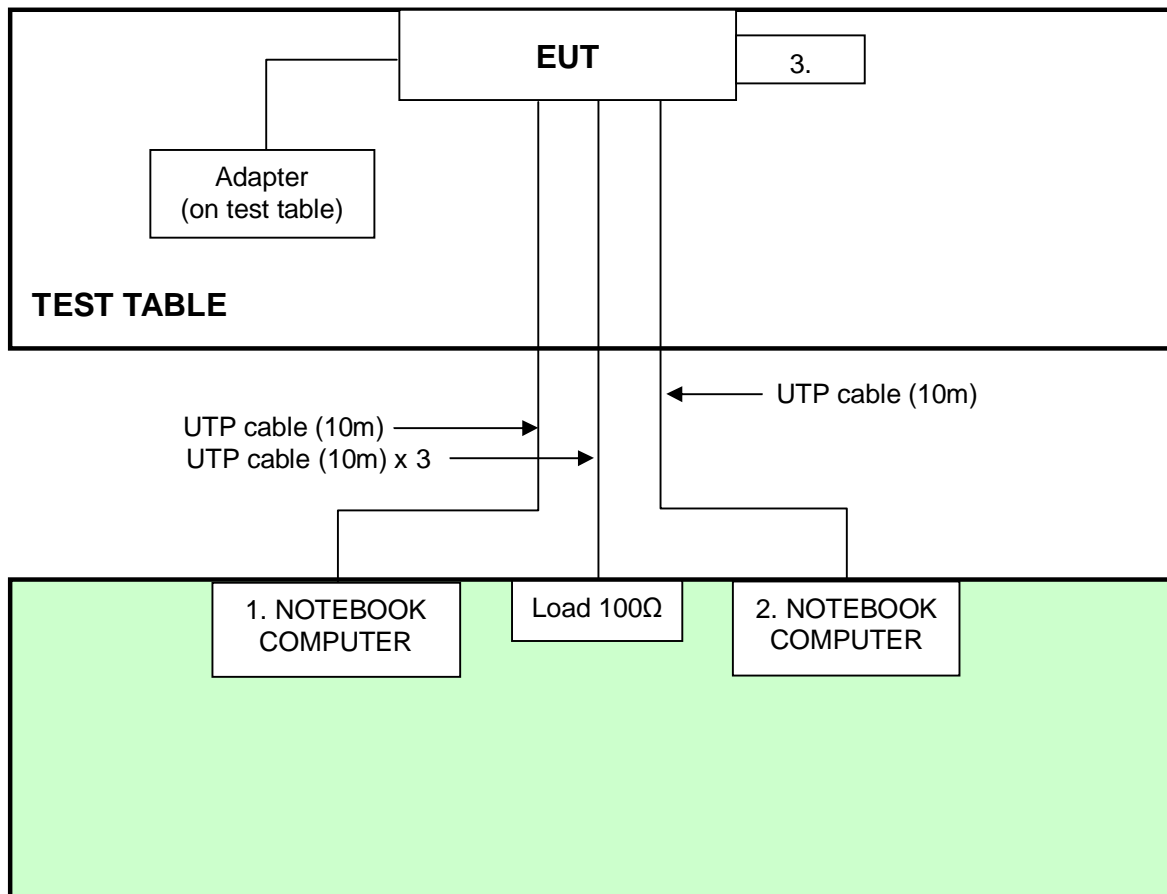



4. TEST TYPES AND RESULTS

4.1 CONDUCTED EMISSION MEASUREMENT

4.1.1 LIMITS OF CONDUCTED EMISSION MEASUREMENT

FREQUENCY OF EMISSION (MHz)	CONDUCTED LIMIT (dB μ V)	
	Quasi-peak	Average
0.15-0.5	66 to 56	56 to 46
0.5-5	56	46
5-30	60	50

- NOTE:**
1. The lower limit shall apply at the transition frequencies.
 2. The limit decreases in line with the logarithm of the frequency in the range of 0.15 to 0.50 MHz.
 3. All emanations from a class A/B digital device or system, including any network of conductors and apparatus connected thereto, shall not exceed the level of field strengths specified above.

4.1.2 TEST INSTRUMENTS

DESCRIPTION & MANUFACTURER	MODEL NO.	SERIAL NO.	CALIBRATED DATE	CALIBRATED UNTIL
ROHDE & SCHWARZ Test Receiver	ESCS 30	100287	Mar. 05, 2009	Mar. 04, 2010
Line-Impedance Stabilization Network (for EUT)	KNW-407	8-1395-12	May 04, 2009	May 03, 2010
Line-Impedance Stabilization Network (for Peripheral)	ENV-216	100072	June 08, 2009	June 07, 2010
RF Cable (JYEBAO)	5DFB	COACAB-001	Dec 15, 2008	Dec 14, 2009
50 ohms Terminator	50	3	Nov. 05, 2008	Nov. 04, 2009
Software	BV ADT_Cond_V7.3.7	NA	NA	NA

Note:

1. The calibration interval of the above test instruments is 12 months and the calibrations are traceable to NML/ROC and NIST/USA.
2. The test was performed in Shielded Room No. A.
3. The VCCI Con A Registration No. is C-817.

4.1.3 TEST PROCEDURES

- a. The EUT was placed 0.4 meters from the conducting wall of the shielded room with EUT being connected to the power mains through a line impedance stabilization network (LISN). Other support units were connected to the power mains through another LISN. The two LISNs provide 50 ohm/ 50uH of coupling impedance for the measuring instrument.
- b. Both lines of the power mains connected to the EUT were checked for maximum conducted interference.
- c. The frequency range from 150kHz to 30MHz was searched. Emission levels under (Limit - 20dB) were not recorded.

4.1.4 DEVIATION FROM TEST STANDARD

No deviation

4.1.5 TEST SETUP

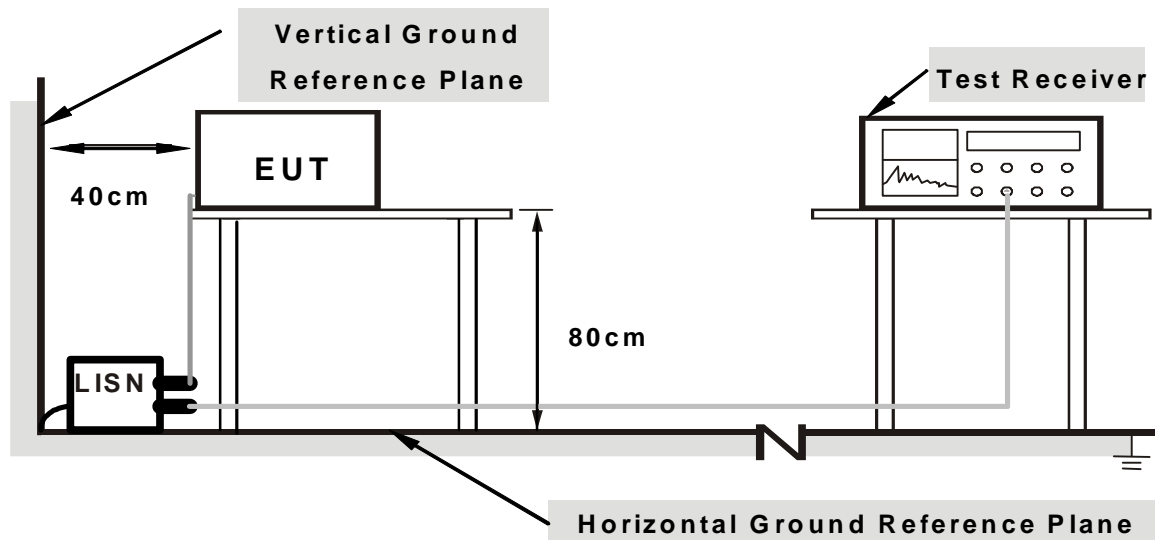

- Note: 1.Support units were connected to second LISN.**
2.Both of LISNs (AMN) are 80 cm from EUT and at least 80 from other units and other metal planes

For the actual test configuration, please refer to the related item – Photographs of the Test Configuration.

4.1.6 EUT OPERATING CONDITIONS

1. Placed the EUT on testing table.
2. Prepared other computer systems (support units 1 ~ 2) to act as communication partners and placed them outside of testing area.
3. The communication partners run test program “RT3052QA.exe” to enable EUT under transmission/receiving condition continuously at specific channel frequency.



A D T

4.1.7 TEST RESULTS

DRAFT 802.11b DSSS MODULATION

EUT TEST CONDITION		MEASUREMENT DETAIL	
CHANNEL	Channel 1	PHASE	Line (L)
INPUT POWER	120Vac, 60 Hz	6DB BANDWIDTH	9 kHz
ENVIRONMENTAL CONDITIONS	26 deg. C, 58 % RH, 965 hPa	TESTED BY	Leo Peng

No	Freq. [MHz]	Corr. Factor (dB)	Reading Value [dB (uV)]		Emission Level [dB (uV)]		Limit [dB (uV)]		Margin (dB)	
			Q.P.	AV.	Q.P.	AV.	Q.P.	AV.	Q.P.	AV.
	1	0.423	0.08	48.10	35.43	48.18	35.51	57.38	47.38	-9.20
2	0.459	0.08	51.32	44.41	51.40	44.49	56.72	46.72	-5.32	-2.23
3	0.509	0.08	44.77	-	44.85	-	56.00	46.00	-11.15	-
4	0.603	0.07	38.76	-	38.83	-	56.00	46.00	-17.17	-
5	0.775	0.07	42.37	-	42.44	-	56.00	46.00	-13.56	-
6	0.965	0.06	42.35	-	42.41	-	56.00	46.00	-13.59	-

- REMARKS:**
1. Q.P. and AV. are abbreviations of quasi-peak and average individually.
 2. "-": The Quasi-peak reading value also meets average limit and measurement with the average detector is unnecessary.
 3. The emission levels of other frequencies were very low against the limit.
 4. Margin value = Emission level - Limit value
 5. Correction factor = Insertion loss + Cable loss
 6. Emission Level = Correction Factor + Reading Value.

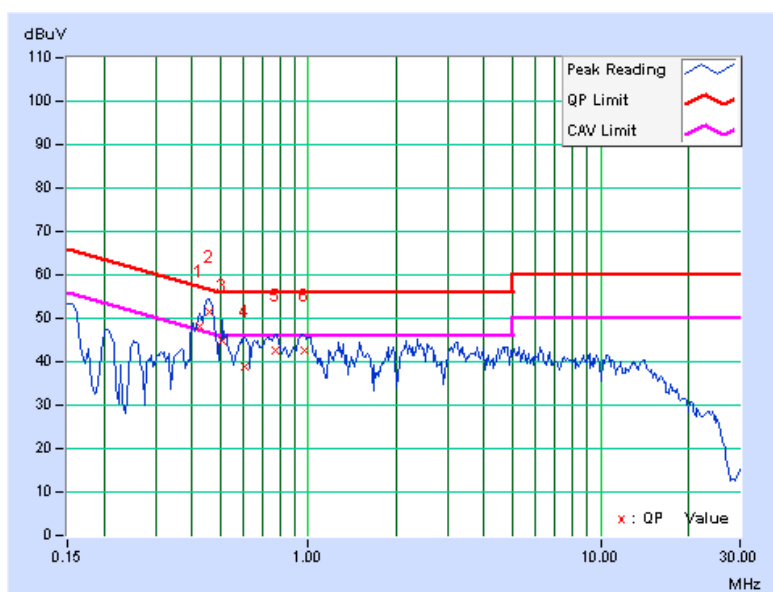



A D T

EUT TEST CONDITION		MEASUREMENT DETAIL	
CHANNEL	Channel 1	PHASE	Neutral (N)
INPUT POWER	120Vac, 60 Hz	6dB BANDWIDTH	9 kHz
ENVIRONMENTAL CONDITIONS	26 deg. C, 58 % RH, 965 hPa	TESTED BY	Leo Peng

No	Freq. [MHz]	Corr. Factor [dB]	Reading Value [dB (uV)]		Emission Level [dB (uV)]		Limit [dB (uV)]		Margin (dB)	
			Q.P.	AV.	Q.P.	AV.	Q.P.	AV.	Q.P.	AV.
			1	0.418	0.09	46.26	-	46.35	-	57.49
2	0.462	0.09	51.16	46.11	51.25	46.20	56.65	46.65	-5.40	-0.45
3	0.615	0.09	39.85	-	39.94	-	56.00	46.00	-16.06	-
4	0.775	0.08	41.70	-	41.78	-	56.00	46.00	-14.22	-
5	0.959	0.08	42.27	-	42.35	-	56.00	46.00	-13.65	-
6	1.887	0.10	38.39	-	38.49	-	56.00	46.00	-17.51	-
7	2.188	0.11	41.95	-	42.06	-	56.00	46.00	-13.94	-

- REMARKS:**
1. Q.P. and AV. are abbreviations of quasi-peak and average individually.
 2. "-": The Quasi-peak reading value also meets average limit and measurement with the average detector is unnecessary.
 3. The emission levels of other frequencies were very low against the limit.
 4. Margin value = Emission level - Limit value
 5. Correction factor = Insertion loss + Cable loss
 6. Emission Level = Correction Factor + Reading Value.

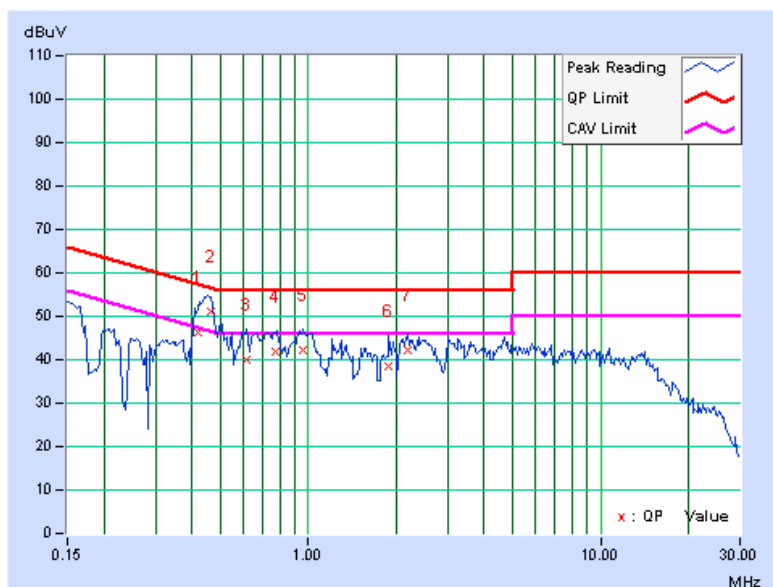



4.2 RADIATED EMISSION MEASUREMENT

4.2.1 LIMITS OF RADIATED EMISSION MEASUREMENT

Emissions radiated outside of the specified bands, shall be according to the general radiated limits in 15.209 as following:

FREQUENCIES (MHz)	FIELD STRENGTH (microvolts/meter)	MEASUREMENT DISTANCE (meters)
0.009 ~ 0.490	2400 / F(kHz)	300
0.490 ~ 1.705	24000 / F(kHz)	30
1.705 ~ 30.0	30	30
30 ~ 88	100	3
88 ~ 216	150	3
216 ~ 960	200	3
Above 960	500	3

NOTE:

1. The lower limit shall apply at the transition frequencies.
2. Emission level (dBuV/m) = 20 log Emission level (uV/m).
3. As shown in 15.35(b), for frequencies above 1000MHz, the field strength limits are based on average detector, however, the peak field strength of any emission shall not exceed the maximum permitted average limits, specified above by more than 20dB under any condition of modulation.



4.2.2 TEST INSTRUMENTS

For below 1GHz test:

DESCRIPTION & MANUFACTURER	MODEL NO.	SERIAL NO.	CALIBRATED DATE	CALIBRATED UNTIL
ADVANTEST Spectrum Analyzer	U3751	17010023	July. 31, 2009	July. 30, 2010
ADVANTEST Spectrum Analyzer	U3772	160100280	July 26, 2009	July 25, 2010
HP Pre_Amplifier	8449B	3008A01922	Sep. 25, 2008	Sep. 24, 2009
ROHDE & SCHWARZ Test Receiver	ESVS 30	841977/002	Nov. 03, 2008	Nov. 02, 2009
SCHAFFNER(CHAS E) Broadband Antenna	CBL6112B	2798	April 29, 2009	April 28, 2010
Schwarzbeck Horn_Antenna	BBHA9120-D 1	D123	Sep. 30, 2008	Sep. 29, 2009
Schwarzbeck Horn_Antenna	BBHA 9170	BBHA917015 3	Jan. 23, 2009	Jan. 22, 2010
RF Switches	MP59B	6100175593	Sep. 02, 2008	Sep. 01, 2009
RF Cable	8DFB	STBCAB-30M -1GHz	Sep. 02, 2008	Sep. 01, 2009
Software	ADT_Radiate d_V7.6.15.9.2	NA	NA	NA
CT Antenna Tower & Turn Table	NA	NA	NA	NA
CORCOM AC Filter	MRI2030	024/019	NA	NA

Note: 1. The calibration interval of the above test instruments is 12 months and the calibrations are traceable to NML/ROC and NIST/USA.

2. The horn antenna, HP preamplifier (model: 8449B) and Spectrum Analyzer (model: U3772) are used only for the measurement of emission frequency above 1GHz if tested.
3. The test was performed in Open Site No. B.
4. The VCCI Site Registration No. is R-847.
5. The FCC Site Registration No. is 92753.
6. The CANADA Site Registration No. is IC 7450G-2.



A D T

For above 1GHz test:

DESCRIPTION & MANUFACTURER	MODEL NO.	SERIAL NO.	CALIBRATED DATE	CALIBRATED UNTIL
ROHDE & SCHWARZ Spectrum Analyzer	FSP40	100036	Dec. 09, 2008	Dec. 08, 2009
Agilent PSA Spectrum Analyzer	E4446A	MY46180622	Apr. 24 , 2009	Apr. 23 , 2010
HP Pre_Amplifier	8449B	3008A01923	Nov. 10, 2008	Nov. 09, 2009
ROHDE & SCHWARZ Test Receiver	ESCS30	847124/029	Sep. 09, 2008	Sep. 08, 2009
SCHWARZBECK TRILOG Broadband Antenna	VULB 9168	138	April 29, 2009	April 28, 2010
Schwarzbeck Horn_Antenna	BBHA9120	D124	Dec. 09, 2008	Dec. 08, 2009
Schwarzbeck Horn_Antenna	BBHA 9170	BBHA9170153	Jan. 22, 2009	Jan. 21, 2010
RF Switches	EMH-011	08009	Oct. 07, 2008	Oct. 06, 2009
RF CABLE (Chaintek)	Sucoflex 106	28077	Aug. 15, 2009	Aug. 14, 2010
RF Cable	8DFB	STCCAB-30M-1GHz	Oct. 07, 2008	Oct. 06, 2009
Software	ADT_Radiated_V7.6.15.9.2	NA	NA	NA
CT Antenna Tower & Turn Table	NA	NA	NA	NA

Note: 1. The calibration interval of the above test instruments is 12 months and the calibrations are traceable to NML/ROC and NIST/USA.

2. The horn antenna, HP preamplifier (model: 8449B) and Spectrum Analyzer (model: FSP40) are used only for the measurement of emission frequency above 1GHz if tested.

3. The test was performed in Open Site No. C.

4. The FCC Site Registration No. is 656396.

5. The VCCI Site Registration No. is R-1626.

6. The CANADA Site Registration No. is IC 7450G-3.

4.2.3 TEST PROCEDURES

- a. The EUT was placed on the top of a rotating table 0.8 meters above the ground at a 10 meter open area test site. The table was rotated 360 degrees to determine the position of the highest radiation.
- b. The EUT was set 3 meters away from the interference-receiving antenna, which was mounted on the top of a variable-height antenna tower.
- c. The antenna is a broadband antenna, and its height is varied from one meter to four meters above the ground to determine the maximum value of the field strength. Both horizontal and vertical polarizations of the antenna are set to make the measurement.
- d. For each suspected emission, the EUT was arranged to its worst case and then the antenna was tuned to heights from 1 meter to 4 meters and the rotatable table was turned from 0 degrees to 360 degrees to find the maximum reading.
- e. The test-receiver system was set to Peak Detect Function and Specified Bandwidth with Maximum Hold Mode.
- f. If the emission level of the EUT in peak mode was lower than the limit specified, then testing could be stopped and the peak values of the EUT would be reported. Otherwise the emissions would be re-tested one by one using peak, quasi-peak or average method as specified and then reported in a data sheet.

NOTE:

1. The resolution bandwidth and video bandwidth of test receiver/spectrum analyzer is 120kHz for Peak detection (PK) and Quasi-peak detection (QP) at frequency below 1GHz.
2. The resolution bandwidth is 1MHz and video bandwidth of test receiver/spectrum analyzer is 3MHz for Peak detection at frequency above 1GHz.
3. The resolution bandwidth of test receiver/spectrum analyzer is 1MHz and the video bandwidth is 10Hz for Average detection (AV) at frequency above 1GHz.

4.2.4 DEVIATION FROM TEST STANDARD

No deviation

4.2.5 TEST SETUP

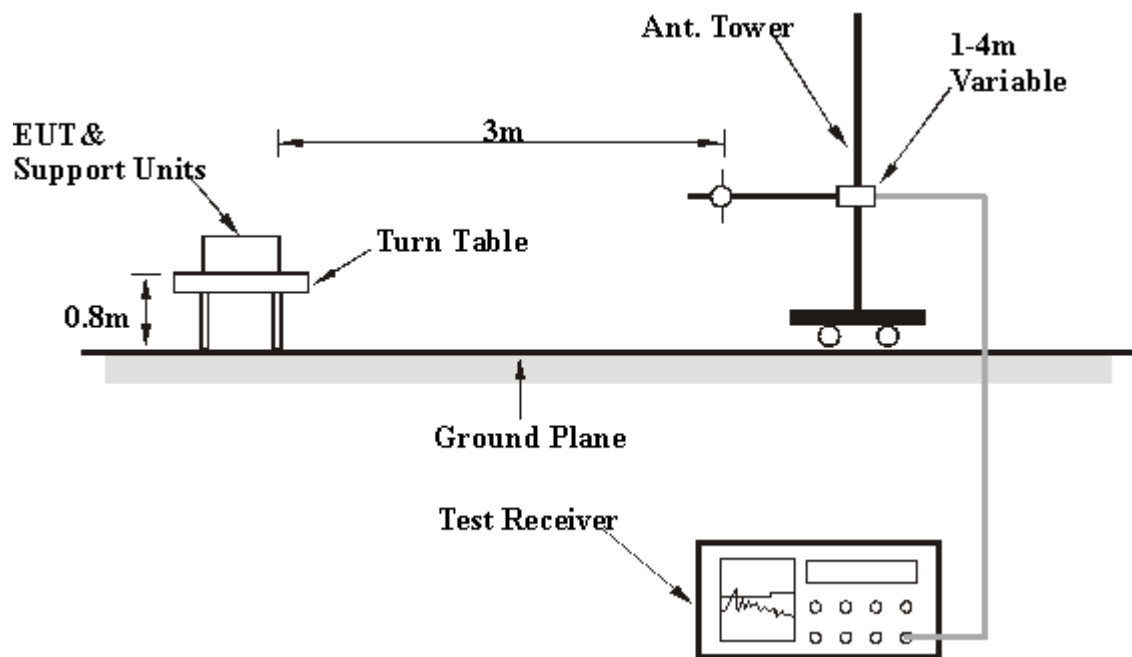

For the actual test configuration, please refer to the related item – Photographs of the Test Configuration.

4.2.6 EUT OPERATING CONDITIONS

Same as 4.1.6



A D T

4.2.7 TEST RESULTS

BELOW 1GHz WORST-CASE DATA : 802.11b DSSS MODULATION

EUT TEST CONDITION		MEASUREMENT DETAIL	
CHANNEL	Channel 1	FREQUENCY RANGE	Below 1000MHz
INPUT POWER	120Vac, 60 Hz	DETECTOR FUNCTION	Quasi-Peak
ENVIRONMENTAL CONDITIONS	29.0deg. C, 67%RH 965hPa	TESTED BY	Eagle Chen

ANTENNA POLARITY & TEST DISTANCE: HORIZONTAL AT 3 M								
NO.	FREQ. (MHz)	EMISSION LEVEL (dBuV/m)	LIMIT (dBuV/m)	MARGIN (dB)	ANTENNA HEIGHT (m)	TABLE ANGLE (Degree)	RAW VALUE (dBuV)	CORRECTION FACTOR (dB/m)
1	125.00	29.3 QP	43.5	-14.2	4.00 H	304	16.06	13.23
2	250.00	33.3 QP	46.0	-12.7	4.00 H	80	19.21	14.12
3	375.01	36.2 QP	46.0	-9.8	3.43 H	310	19.20	16.99
4	500.01	35.3 QP	46.0	-10.7	3.02 H	76	15.80	19.49
5	625.01	34.8 QP	46.0	-11.2	3.22 H	326	14.19	20.61
6	875.00	32.8 QP	46.0	-13.2	1.00 H	82	10.06	22.71
7	1000.00	38.9 QP	54.0	-15.1	1.00 H	321	15.50	23.43

ANTENNA POLARITY & TEST DISTANCE: VERTICAL AT 3 M								
NO.	FREQ. (MHz)	EMISSION LEVEL (dBuV/m)	LIMIT (dBuV/m)	MARGIN (dB)	ANTENNA HEIGHT (m)	TABLE ANGLE (Degree)	RAW VALUE (dBuV)	CORRECTION FACTOR (dB/m)
1	125.00	32.1 QP	43.5	-11.4	1.00 V	253	18.91	13.23
2	250.00	37.1 QP	46.0	-8.9	1.00 V	338	23.00	14.12
3	375.00	36.6 QP	46.0	-9.4	1.00 V	76	19.60	16.99
4	500.01	36.0 QP	46.0	-10.0	1.00 V	104	16.50	19.49
5	625.01	37.2 QP	46.0	-8.8	2.61 V	137	16.63	20.61
6	875.01	33.9 QP	46.0	-12.1	1.93 V	134	11.23	22.71
7	1000.00	40.2 QP	54.0	-13.9	1.98 V	72	16.75	23.43

- REMARKS:** 1. Emission level (dBuV/m) = Raw Value (dBuV) + Correction Factor (dB/m).
2. Correction Factor (dB/m) = Antenna Factor (dB/m) + Cable Factor (dB).
3. The other emission levels were very low against the limit.
4. Margin value = Emission level – Limit value.

**DRAFT 802.11n (20MHz) OFDM MODULATION**

EUT TEST CONDITION		MEASUREMENT DETAIL	
CHANNEL	Channel 1	FREQUENCY RANGE	1 ~ 25GHz
INPUT POWER (SYSTEM)	120Vac, 60 Hz	DETECTOR FUNCTION	Peak (PK) Average (AV)
ENVIRONMENTAL CONDITIONS	28deg. C, 56%RH 965 hPa	TESTED BY	Eric Lee

ANTENNA POLARITY & TEST DISTANCE: HORIZONTAL AT 3 M								
NO.	FREQ. (MHz)	EMISSION LEVEL (dBuV/m)	LIMIT (dBuV/m)	MARGIN (dB)	ANTENNA HEIGHT (m)	TABLE ANGLE (Degree)	RAW VALUE (dBuV)	CORRECTION FACTOR (dB/m)
1	2390.00	65.3 PK	74.0	-8.7	1.49 H	310	35.28	30.06
2	2390.00	46.3 AV	54.0	-7.7	1.49 H	310	16.28	30.06
3	*2412.00	102.1 PK			1.60 H	324	71.93	30.15
4	*2412.00	96.8 AV			1.60 H	324	66.62	30.15
5	4824.00	47.3 PK	74.0	-26.7	1.46 H	5	11.82	35.46
6	4824.00	34.7 AV	54.0	-19.3	1.46 H	5	-0.79	35.46
ANTENNA POLARITY & TEST DISTANCE: VERTICAL AT 3 M								
NO.	FREQ. (MHz)	EMISSION LEVEL (dBuV/m)	LIMIT (dBuV/m)	MARGIN (dB)	ANTENNA HEIGHT (m)	TABLE ANGLE (Degree)	RAW VALUE (dBuV)	CORRECTION FACTOR (dB/m)
1	2360.13	50.0 AV	54.0	-4.0	1.29 V	145	20.04	29.94
2	2388.93	72.3 PK	74.0	-1.7	1.29 V	145	42.26	30.06
3	*2412.00	107.1 PK			1.26 V	144	76.95	30.15
4	*2412.00	91.7 AV			1.26 V	144	61.52	30.15
5	4824.00	49.4 PK	74.0	-24.6	1.46 V	5	13.90	35.46
6	4824.00	38.1 AV	54.0	-15.9	1.46 V	5	2.65	35.46

- REMARKS:**
1. Emission level (dBuV/m) = Raw Value (dBuV) + Correction Factor (dB/m).
 2. Correction Factor (dB/m) = Antenna Factor (dB/m) + Cable Factor (dB).
 3. The other emission levels were very low against the limit.
 4. Margin value = Emission level – Limit value.
 5. “ * “: Fundamental frequency.



A D T

EUT TEST CONDITION		MEASUREMENT DETAIL	
CHANNEL	Channel 6	FREQUENCY RANGE	1 ~ 25GHz
INPUT POWER (SYSTEM)	120Vac, 60 Hz	DETECTOR FUNCTION	Peak (PK) Average (AV)
ENVIRONMENTAL CONDITIONS	28deg. C, 56%RH 965 hPa	TESTED BY	Eric Lee

ANTENNA POLARITY & TEST DISTANCE: HORIZONTAL AT 3 M								
NO.	FREQ. (MHz)	EMISSION LEVEL (dBuV/m)	LIMIT (dBuV/m)	MARGIN (dB)	ANTENNA HEIGHT (m)	TABLE ANGLE (Degree)	RAW VALUE (dBuV)	CORRECTION FACTOR (dB/m)
1	*2437.00	99.7 PK			1.30 H	68	69.44	30.24
2	*2437.00	94.5 AV			1.30 H	68	64.28	30.24
3	4874.00	47.7 PK	74.0	-27.0	1.22 H	146	11.51	35.55
4	4874.00	34.3 AV	54.0	-19.7	1.22 H	146	-1.26	35.55
5	7311.00	54.1 PK	74.0	-19.9	1.72 H	190	12.07	42.04
6	7311.00	37.3 AV	54.0	-16.8	1.72 H	190	-4.79	42.04
ANTENNA POLARITY & TEST DISTANCE: VERTICAL AT 3 M								
NO.	FREQ. (MHz)	EMISSION LEVEL (dBuV/m)	LIMIT (dBuV/m)	MARGIN (dB)	ANTENNA HEIGHT (m)	TABLE ANGLE (Degree)	RAW VALUE (dBuV)	CORRECTION FACTOR (dB/m)
1	2388.00	64.8 PK	74.0	-9.2	1.11 V	20	34.78	30.05
2	2388.00	48.7 AV	54.0	-5.3	1.11 V	20	18.64	30.05
3	*2437.00	105.8 PK			1.24 V	50	75.56	30.24
4	*2437.00	90.9 AV			1.24 V	50	60.66	30.24
5	2483.50	73.4 PK	74.0	-0.6	1.23 V	39	42.97	30.43
6	2483.50	49.3 AV	54.0	-4.7	1.23 V	39	18.90	30.43
7	4874.00	49.9 PK	74.0	-24.1	1.43 V	304	14.31	35.55
8	4874.00	38.5 AV	54.0	-15.5	1.43 V	304	2.97	35.55
9	7311.00	58.0 PK	74.0	-16.0	1.50 V	286	15.95	42.04
10	7311.00	43.6 AV	54.0	-10.4	1.50 V	286	1.60	42.04

- REMARKS:**
1. Emission level (dBuV/m) = Raw Value (dBuV) + Correction Factor (dB/m).
 2. Correction Factor (dB/m) = Antenna Factor (dB/m) + Cable Factor (dB).
 3. The other emission levels were very low against the limit.
 4. Margin value = Emission level – Limit value.
 5. “ * “: Fundamental frequency.



A D T

EUT TEST CONDITION		MEASUREMENT DETAIL	
CHANNEL	Channel 11	FREQUENCY RANGE	1 ~ 25GHz
INPUT POWER (SYSTEM)	120Vac, 60 Hz	DETECTOR FUNCTION	Peak (PK) Average (AV)
ENVIRONMENTAL CONDITIONS	28deg. C, 56%RH 965 hPa	TESTED BY	Eric Lee

ANTENNA POLARITY & TEST DISTANCE: HORIZONTAL AT 3 M								
NO.	FREQ. (MHz)	EMISSION LEVEL (dBuV/m)	LIMIT (dBuV/m)	MARGIN (dB)	ANTENNA HEIGHT (m)	TABLE ANGLE (Degree)	RAW VALUE (dBuV)	CORRECTION FACTOR (dB/m)
1	*2462.00	102.7 PK			1.28 H	340	72.36	30.34
2	*2462.00	87.3 AV			1.28 H	340	56.95	30.34
3	2483.50	64.3 PK	74.0	-9.7	1.30 H	351	33.86	30.43
4	2483.50	42.5 AV	54.0	-11.5	1.30 H	351	12.07	30.43
5	4924.00	45.7 PK	74.0	-28.4	1.22 H	248	10.02	35.63
6	4924.00	34.2 AV	54.0	-19.8	1.22 H	248	-1.46	35.63
7	7386.00	53.7 PK	74.0	-20.3	1.23 H	354	11.44	42.23
8	7386.00	40.8 AV	54.0	-13.2	1.23 H	354	-1.43	42.23
ANTENNA POLARITY & TEST DISTANCE: VERTICAL AT 3 M								
NO.	FREQ. (MHz)	EMISSION LEVEL (dBuV/m)	LIMIT (dBuV/m)	MARGIN (dB)	ANTENNA HEIGHT (m)	TABLE ANGLE (Degree)	RAW VALUE (dBuV)	CORRECTION FACTOR (dB/m)
1	*2462.00	109.0 PK			1.19 V	350	78.65	30.34
2	*2462.00	92.9 AV			1.19 V	350	62.53	30.34
3	2483.50	71.7 PK	74.0	-2.3	1.13 V	245	41.27	30.43
4	2483.50	45.2 AV	54.0	-8.8	1.13 V	245	14.80	30.43
5	4924.00	46.8 PK	74.0	-27.2	1.57 V	111	11.17	35.63
6	4924.00	35.1 AV	54.0	-18.9	1.57 V	111	-0.57	35.63
7	7386.00	54.3 PK	74.0	-19.7	1.26 V	222	12.05	42.23
8	7386.00	41.2 AV	54.0	-12.9	1.26 V	222	-1.11	42.23

- REMARKS:**
1. Emission level (dBuV/m) = Raw Value (dBuV) + Correction Factor (dB/m).
 2. Correction Factor (dB/m) = Antenna Factor (dB/m) + Cable Factor (dB).
 3. The other emission levels were very low against the limit.
 4. Margin value = Emission level – Limit value.
 5. “ * “: Fundamental frequency.



A D T

RESTRICTED BANDEDGE (DRAFT 802.11n (20MHz) MODE, CH1, HORIZONTAL)

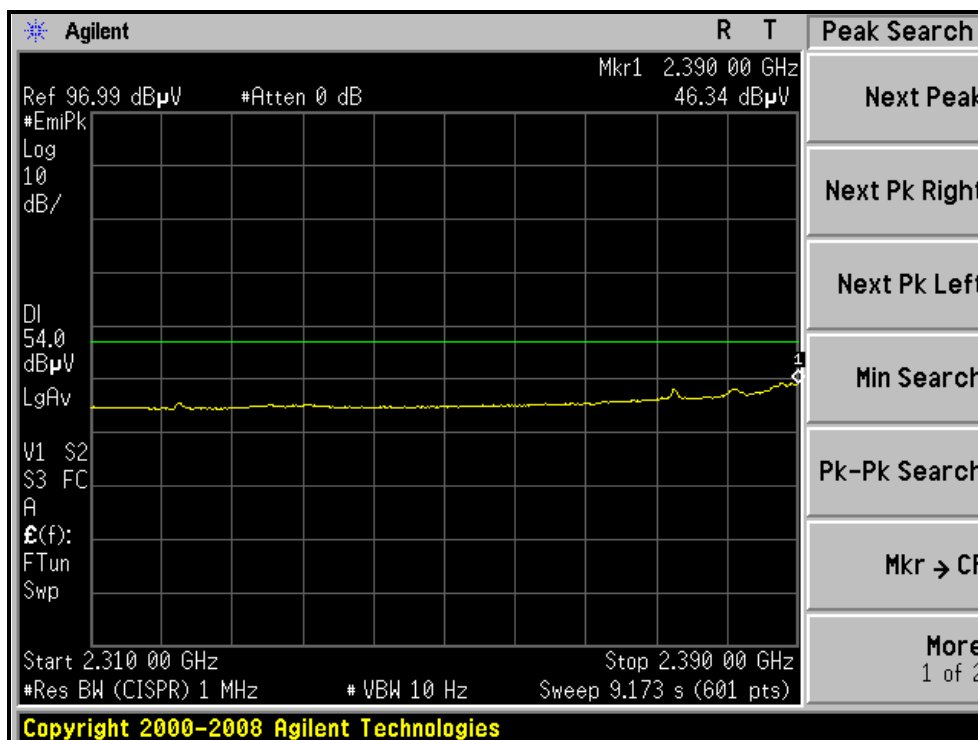
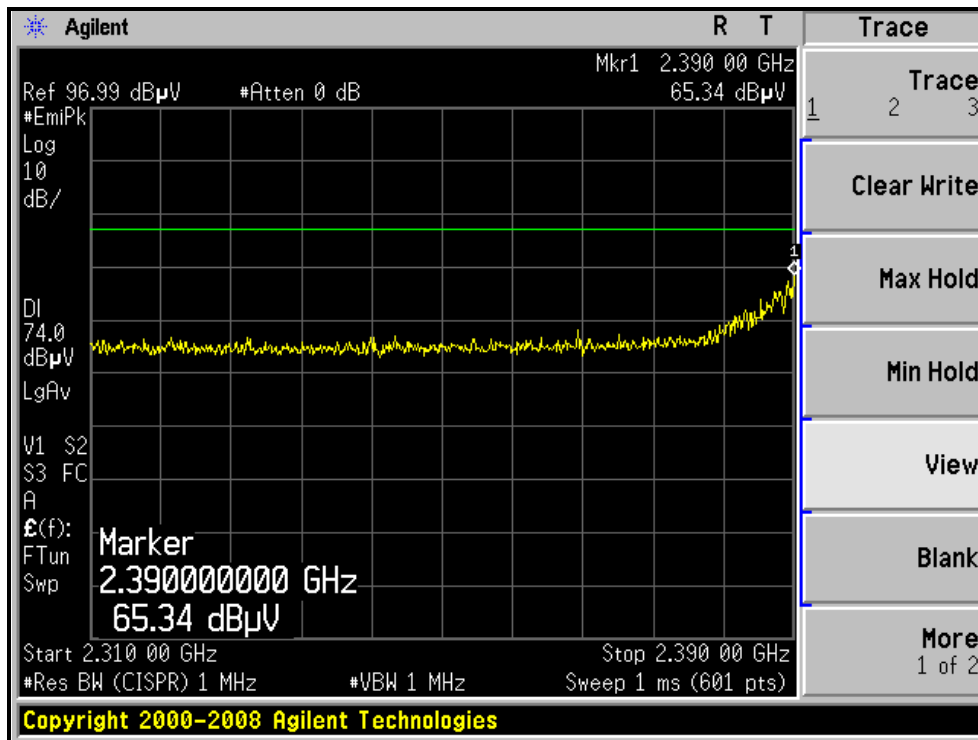



A D T

RESTRICTED BANDEDGE (DRAFT 802.11n (20MHz) MODE,CH1, VERTICAL)

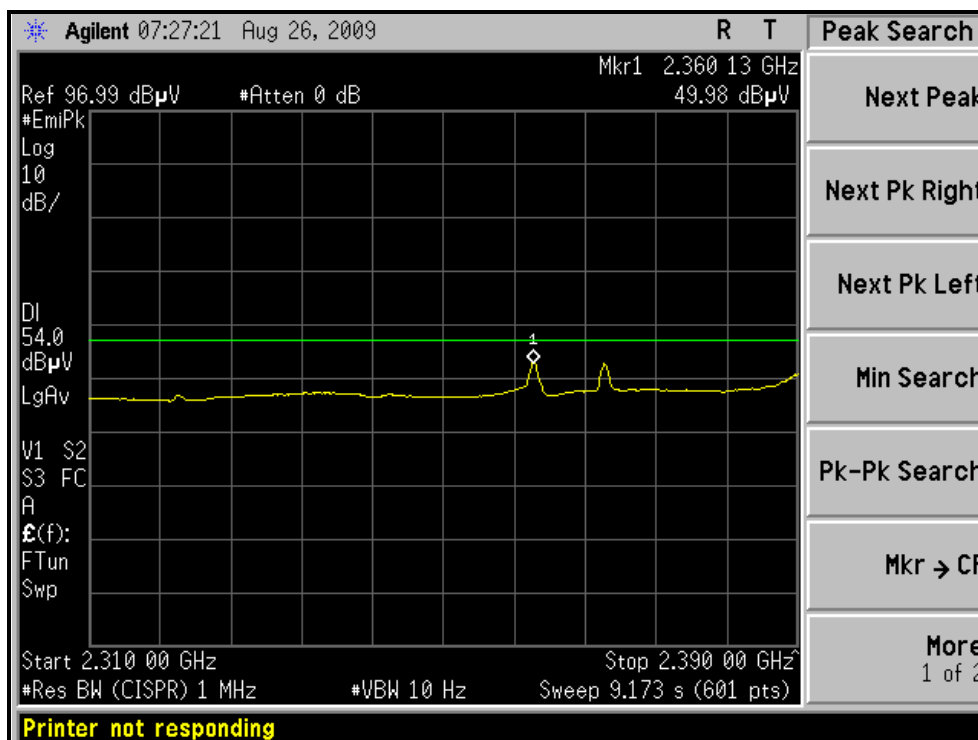
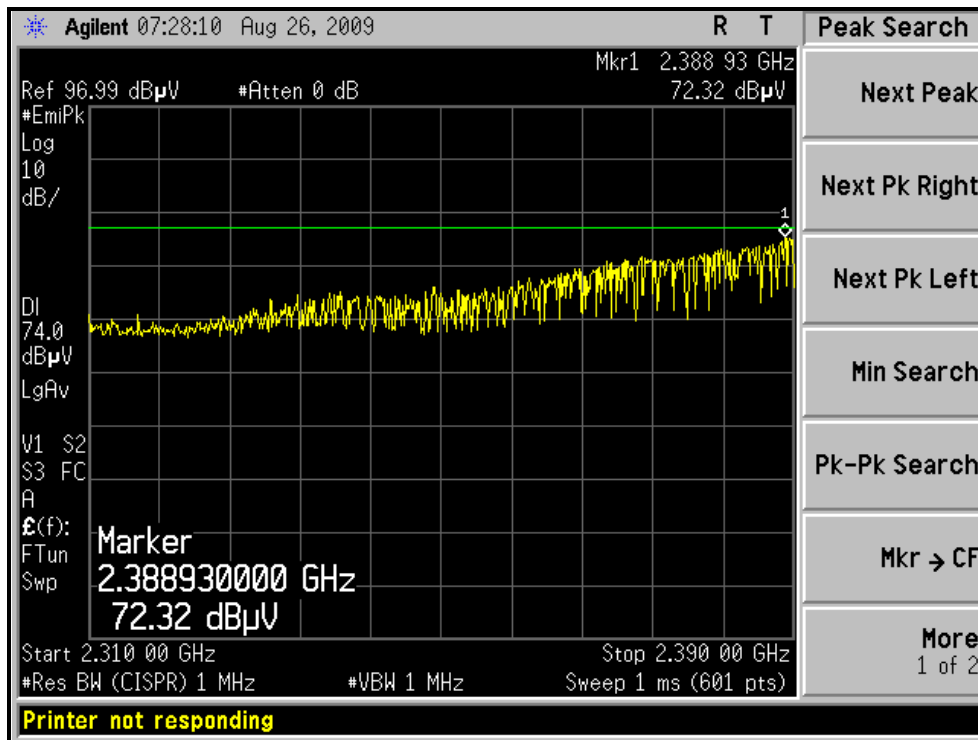



A D T

RESTRICTED BANDEDGE (DRAFT 802.11n (20MHz) MODE, CH11, HORIZONTAL)

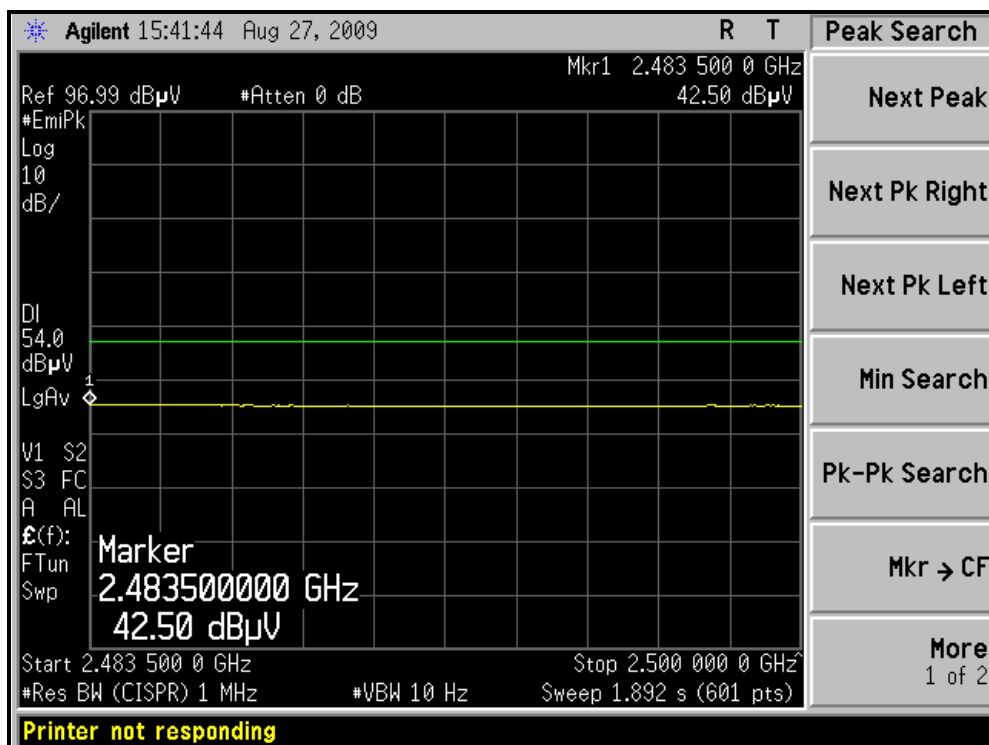
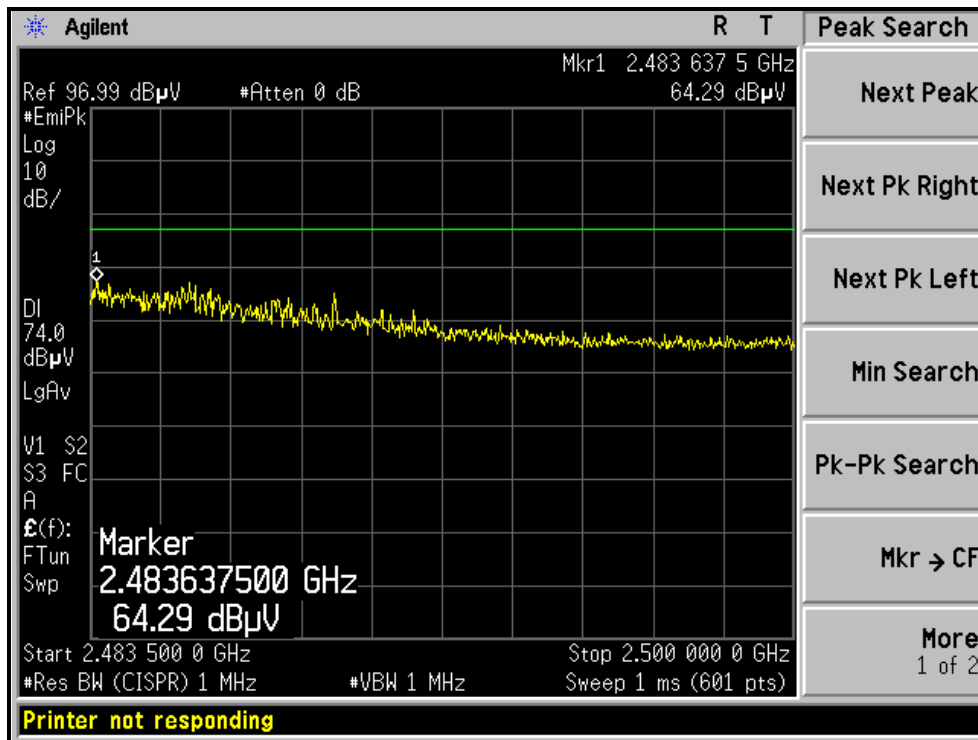



A D T

RESTRICTED BANDEDGE (DRAFT 802.11n (20MHz) MODE,CH11, VERTICAL)

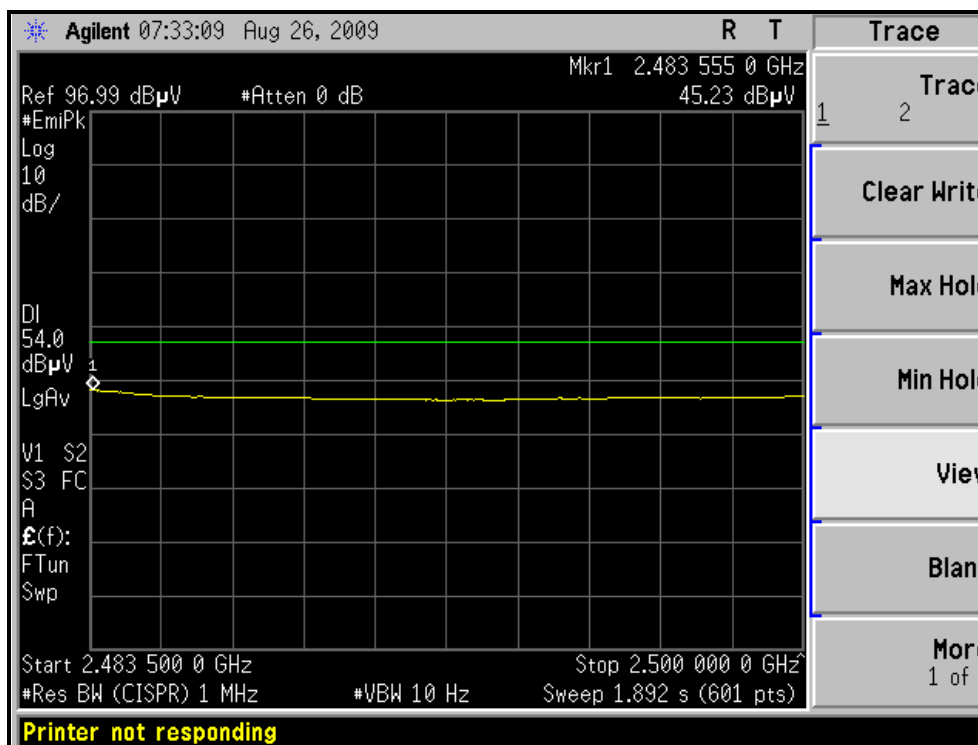
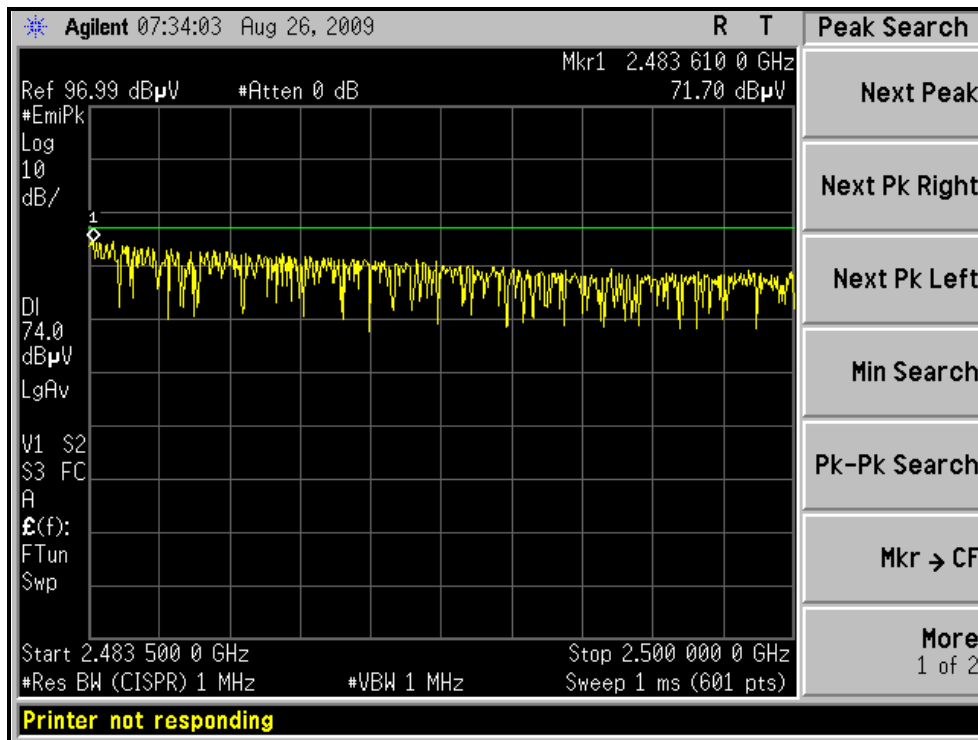



A D T

5. INFORMATION ON THE TESTING LABORATORIES

We, Bureau Veritas Consumer Products Services (H.K.) Ltd., Taoyuan Branch, were founded in 1988 to provide our best service in EMC, Radio, Telecom and Safety consultation. Our laboratories are accredited and approved by the following approval agencies according to ISO/IEC 17025.

USA	FCC, NVLAP
Germany	TUV Rheinland
Japan	VCCI
Norway	NEMKO
Canada	INDUSTRY CANADA, CSA
R.O.C.	TAF, BSMI, NCC
Netherlands	Telefication
Singapore	GOST-ASIA(MOU)
Russia	CERTIS(MOU)

Copies of accreditation certificates of our laboratories obtained from approval agencies can be downloaded from our web site: www.adt.com.tw/index.5/phtml.
If you have any comments, please feel free to contact us at the following:

Linko EMC/RF Lab:

Tel: 886-2-26052180

Fax: 886-2-26052943

Hsin Chu EMC/RF Lab:

Tel: 886-3-5935343

Fax: 886-3-5935342

Hwa Ya EMC/RF/Safety Telecom Lab:

Tel: 886-3-3183232

Fax: 886-3-3185050

Web Site: www.adt.com.tw

The address and road map of all our labs can be found in our web site also.



A D T

6. APPENDIX - A MODIFICATIONS RECORDERS FOR ENGINEERING CHANGES TO THE EUT BY THE LAB

No any modifications are made to the EUT by the lab during the test.

--- END ---