



FCC TEST REPORT

According to

FCC Rules and Regulations Part 15 Subpart C

Applicant	:	DWnet Technology (Suzhou) Co., Ltd.
Address	:	6F, No. 26, XinHai Street, Suzhou, JiangSu, 215021, China
Equipment	:	Wireless Access Point
Model No.	:	AP52GA
FCC ID	:	V8DAP52GA
Trade Name	:	DWnet

Laboratory Accreditation



Testing Laboratory
1332

- The test result refers exclusively to the test presented test model / sample.,
- Without written approval of **CerpPASS Technology Corp.** the test report shall not be reproduced except in full.
- The EUT is also considered as a kind of computer peripheral, because the connection to computer is necessary for typical use. It has been verified to comply with the requirements of FCC Part 15, Subpart B, Class B (DoC). The test report has been issued separately.



Contents

1. Report of Measurements and Examinations	5
1.1 List of Measurements and Examinations	5
2. Test Configuration of Equipment under Test	6
2.1 Feature of Equipment under Test.....	6
2.2 Carrier Frequency of Channels	7
2.3 Test Mode and Test Software	7
2.4 Description of Test System.....	7
2.5 Connection Diagram of Test System.....	8
2.6 General Information of Test.....	9
2.7 Measurement Uncertainty	9
2.8 History of this test report	10
3. Antenna Requirements	11
3.1 Standard Applicable	11
3.2 Antenna Construction and Directional Gain.....	11
4. Test of Conducted Emission	12
4.1 Test Limit	12
4.2 Test Procedures	12
4.3 Typical Test Setup	13
4.4 Measurement equipment	13
4.5 Test Result and Data	14
4.6 Test Photographs	18
5. Test of Radiated Emission	19
5.1 Test Limit	19
5.2 Test Procedures	19
5.3 Typical Test Setup	20
5.4 Measurement equipment	20
5.5 Test Result and Data	21
5.6 Test Photographs	53
6. 6dB Bandwidth Measurement Data	54
6.1 Test Limit	54
6.2 Test Procedures	54
6.3 Test Setup Layout	54
6.4 Measurement equipment	54
6.5 Test Result and Data.....	54
7. Maximum Peak Output Power	58
7.1 Test Limit	58
7.2 Test Procedures	58
7.3 Test Setup Layout	58
7.4 Measurement equipment	58
7.5 Test Result and Data.....	58
8. Band Edges Measurement	62
8.1 Test Limit	62
8.2 Test Procedure	62



8.3 Test Setup Layout 62

8.4 Measurement equipment 62

8.5 Test Result and Data 62

8.6 Restrict Band Emission Measurement Data 67

9. Power Spectral Density 69

9.1 Test Limit 69

9.2 Test Procedures 69

9.3 Test Setup Layout 69

9.4 Measurement equipment 69

9.5 Test Result and Data 69

10. Restricted Bands of Operation 73

10.1 Labeling Requirement 73

Appendix A. Photographs of EUT A1 ~ A8



CERTIFICATE OF COMPLIANCE

According to

FCC Rules and Regulations Part 15 Subpart C

Applicant : DWnet Technology (Suzhou) Co., Ltd.

Address : 6F, No. 26, XinHai Street, Suzhou, JiangSu,
215021, China

Equipment : Wireless Access Point

Model No. : AP52GA

FCC ID : V8DAP52GA

I **HEREBY** CERTIFY THAT :

The measurements shown in this test report were made in accordance with the procedures given in **ANSI C63.4** The equipment was **passed** the test performed according to **FCC Rules and Regulations Part 15 Subpart C (2007)**.

The test was carried out on Jun. 12, 2009 at **Cerpass Technology Corp.**

Signature

Anson Chou
EMC/RF B.U. Vice General Manager



1. Report of Measurements and Examinations

1.1 List of Measurements and Examinations

FCC Rule	Description of Test	Result
15.203	. Antenna Requirement	Pass
15.207	. Conducted Emission	Pass
15.209 15.247(d)	. Radiated Emission	Pass
15.247(a)(2)	. 6dB Bandwidth	Pass
15.247(b)	. Maximum Peak Output Power	Pass
15.247(d)	. 100kHz Bandwidth of Frequency Band Edges	Pass
15.247(e)	. Power Spectral Density	Pass
1.1307 1.1310 2.1091 2.1093	. RF Exposure Compliance	Pass



2. Test Configuration of Equipment under Test

2.1 Feature of Equipment under Test

Hardware Specifications	
CPU	AR2312
Radio-on-Chip	AR2112
DRAM	8 Mbytes
Flash ROM	2 Mbytes
LAN port	1 x Auto-MDIX RJ 45 for 10/100Mbps Ethernet
Wireless Interface	Embedded Atheros solution
	Network Standard IEEE 802.11b (Wi-Fi™) and IEEE 802.11g compliance
	OFDM; 802.11b: CCK (11 Mbps, 5.5 Mbps), DQPSK (2 Mbps), DBPSK (1 Mbps)
	Operating Frequencies 2.412-2.497 GHz
	Operating Channels 802.11g: 13 for North America, 13 for Europe (ETSI), 14 for Japan 802.11b: 11 for North America, 14 for Japan, 13 for Europe (ETSI)
Operating temperature	0~55°C
Storage temperature	-20°C~70°C
Power Adapter	- MU12-G120100-A1 \ 12V / 1A - RHN-120100-1-3 \ 12V / 1A
Dimensions	141mm (W) x 100mm (D) x 27mm (H)
Wireless Specifications	
Receive Sensitivity at 11Mbps	min. -85dBm
Receive Sensitivity at 5.5Mbps	min. -89dBm
Receive Sensitivity at 2Mbps	min. -90dBm
Receive Sensitivity at 1Mbps	min. -93dBm
Maximum Receive Level	min. -5dBm
Transmit Power	20 dBm
Modulation	Direct Sequence Spread Spectrum BPSK / QPSK / CCK
Throughput	Up to 19 Mbps
Operating Range	Indoors
	<ul style="list-style-type: none">• 30 Meters (100ft.) @ 11Mbps• 50 Meters (165ft.) @ 5.5Mbps• 70 Meters (230ft.) @ 2Mbps• 91 Meters (300ft.) @ 1Mbps• 152 Meters (500ft.) @ 11Mbps• 270 Meters (885ft.) @ 5.5Mbps• 396 Meters (1300ft.) @ 2 Mbps• 457 Meters (1500ft.) @ 1 Mbps



2.2 Carrier Frequency of Channels

802.11b, 802.11g

Channel	Frequency(MHz)	Channel	Frequency(MHz)
01	2412	07	2442
02	2417	08	2447
03	2422	09	2452
04	2427	10	2457
05	2432	11	2462
06	2437	12	---

2.3 Test Mode and Test Software

- During testing, the interface cables and equipment positions were varied according to ANSI C63.4.
- The complete test system included remote workstation, PC, Monitor, Mouse, Keyboard, Printer and EUT for EMI test. The remote workstation included Notebook.
- An executive program, "Ping.exe" under WIN XP, which transmits and receives data to the remote workstation through Wireless.
- The following test mode and test software was performed for conduction and radiation test:
 - Test Mode 1: Adapter: MU12-G120100-A1
 - 802.11b/g: CH01: 2412MHz, CH06: 2437MHz, CH11: 2462MHz
 - Test Mode 2: Adapter: RHN-120100-1-3
 - 802.11b/g: CH01: 2412MHz, CH06: 2437MHz, CH11: 2462MHz

2.4 Description of Test System

Device	Manufacturer	Model No.	Description
PC	IBM	IGV	Power Cable, Unshielding 1.8 m
Monitor	ViewSonic	G90fB	Data Cable, VGA Shielding 1.35 m Power Cable, Adapter Unshielding 1.8 m
Keyboard	IBM	KB-0225	Data Cable, PS2 Shielding 1.35 m
Mouse	IBM	MO28VO	Data Cable, USB Shielding 1.85 m
Printer	HP	Desk Jet 400	Data Cable, PRINT Unshielding 1.6 m Power Cable, Adapter Unshielding 1.8 m
Remote workstation			
Notebook	TOSHIBA	PSA50T-05M00C	Power Cable, Adapter Unshielding 1.8 m
Notebook	DELL	PP10L	Power Cable, Adapter Unshielding 1.8 m

Use Cable:

Cable	Quantity	Description
RJ45	1	Unshielding, 3.0m
RS232	1	Unshielding, 1.5m



2.5 Connection Diagram of Test System

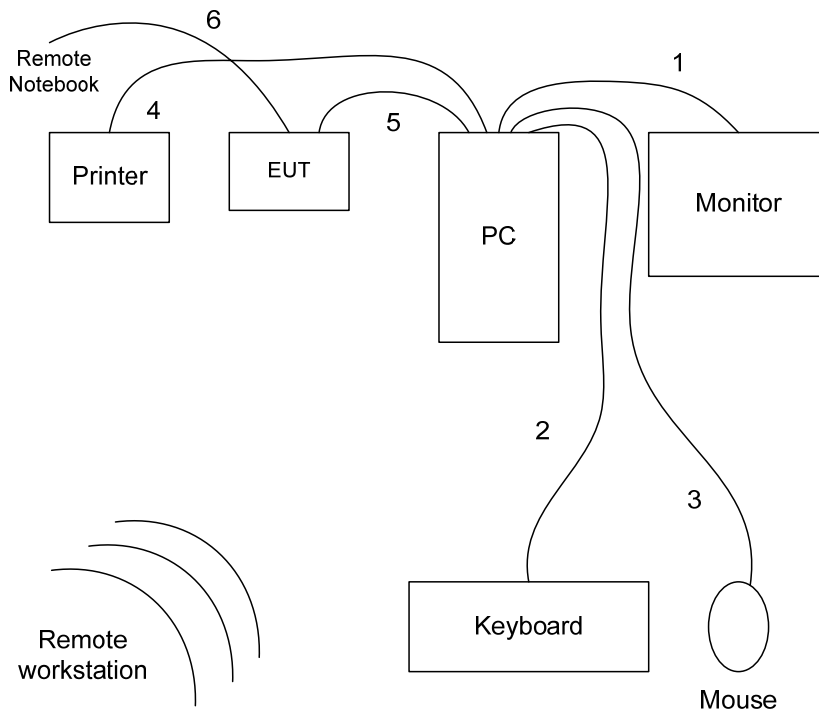

1. The VGA cable is connected from PC to the Monitor.
 2. The PS/2 cable is connected from PC to the Keyboard.
 3. The USB cable is connected from PC to the Mouse.
 4. The Print cable is connected from PC to the Printer.
 5. The RS232 cable is connected from PC to the EUT.
 6. The RJ45 cable is connected from EUT to the remote workstation.
- * The EUT keeps to transmit and receive data via Notebook by Wireless.



2.6 General Information of Test

Test Site :	CerpPASS Technology Corp. 2F-11, No. 3, Yuan Qu St., (Nankang Software Park), Taipei, Taiwan 115, R.O.C.
Test Site Location (OATS1-SD):	No. 7-2, Moshihkeng, Fongtian Village, Shihding Township, Taipei County, Taiwan, R.O.C.
FCC Registration Number :	TW1049, 982971
IC Registration Number :	4934C-1
VCCI Registration Number :	T-182 for Telecommunication Test C-2188 for Conducted emission test R-1902 for Radiated emission test
Test Voltage:	AC 120V
Test in Compliance with:	ANSI C63.4-2003 FCC Part 15 Subpart C
Frequency Range Investigated:	Conducted: from 150kHz to 30MHz Radiation: from 30MHz to 24620MHz
Test Distance:	The test distance of radiated emission from antenna to EUT is 3 M.

2.7 Measurement Uncertainty

Measurement Item	Measurement Frequency	Polarization	Uncertainty
Conducted Emission	9 kHz ~ 30 MHz	LINE/NEUTRAL	2.71 dB
Radiated Emission	30 MHz ~ 25GHz	Vertical	4.11 dB
		Horizontal	4.10 dB
6 dB Bandwidth	---	---	7500 Hz
Maximum Peak Output Power	---	---	1.4 dB
100kHz Bandwidth of Frequency Band Edges	---	---	2.2 dB
Power Spectral Density	---	---	2.2 dB



3. Antenna Requirements

3.1 Standard Applicable

For intentional device, according to FCC 47 CFR Section 15.203, an intentional radiator shall be designed to ensure that no antenna other than that furnished by the responsible party shall be used with the device.

And according to FCC 47 CFR Section 15.247 (b), if transmitting antennas of directional gain greater than 6dBi are used, the power shall be reduced by the amount in dB that the directional gain of the antenna exceeds 6dBi.

3.2 Antenna Construction and Directional Gain

Antenna type: Dipole Antenna

Antenna Gain: 3 dBi



4. Test of Conducted Emission

4.1 Test Limit

Conducted Emissions were measured from 150 kHz to 30 MHz with a bandwidth of 9 KHz on the 120 VAC power and return leads of the EUT according to the methods defined in ANSI C63.4-2003 Section 3.1. The EUT was placed on a nonmetallic stand in a shielded room 0.8 meters above the ground plane as shown in section 2.2. The interface cables and equipment positioning were varied within limits of reasonable applications to determine the position produced maximum conducted emissions.

Frequency (MHz)	Quasi Peak (dB μ V)	Average (dB μ V)
0.15 – 0.5	66-56*	56-46*
0.5 – 5.0	56	46
5.0 – 30.0	60	50

*Decreases with the logarithm of the frequency.

4.2 Test Procedures

- The EUT was placed 0.4 meter from the conducting wall of the shielding room was kept at least 80 centimeters from any other grounded conducting surface.
- Connect EUT to the power mains through a line impedance stabilization network (LISN).
- All the support units are connecting to the other LISN.
- The LISN provides 50 ohm coupling impedance for the measuring instrument.
- The FCC states that a 50 ohm, 50 micro-Henry LISN should be used.
- Both sides of AC line were checked for maximum conducted interference.
- The frequency range from 150 kHz to 30 MHz was searched.
- Set the test-receiver system to Peak Detect Function and Specified Bandwidth with Maximum Hold Mode.



4.3 Typical Test Setup

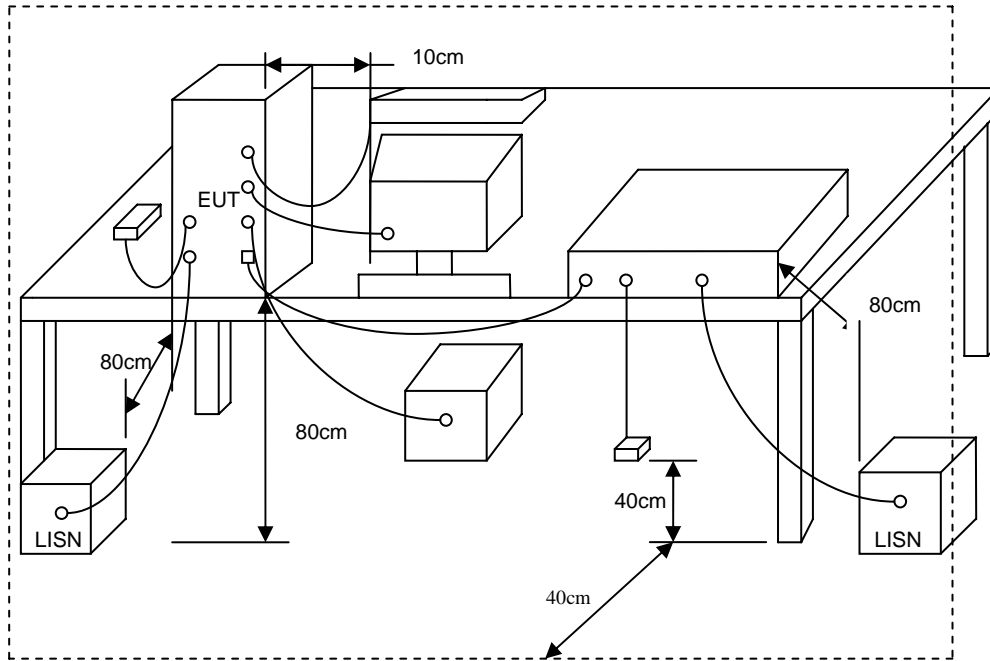

4.4 Measurement equipment

Instrument/Ancillary	Manufacturer	Model No.	Serial No.	Calibration Date	Valid Date.
EMI Receiver	R&S	ESCI	100443	2008/09/27	2009/09/26
LISN	MESS TEC	NNB-2/16Z	02/10191	2008/05/14	2009/06/02
LISN	ROLF HEINE	NNB-2/16Z	03/10058	2009/04/18	2010/04/17



4.5 Test Result and Data

Power	: AC 120V	Pol/Phase	: LINE
Test Mode 1	: 802.11g CH1	Temperature	: 25 °C
Memo	: Adapter: MU12-G120100-A1	Humidity	: 55 %

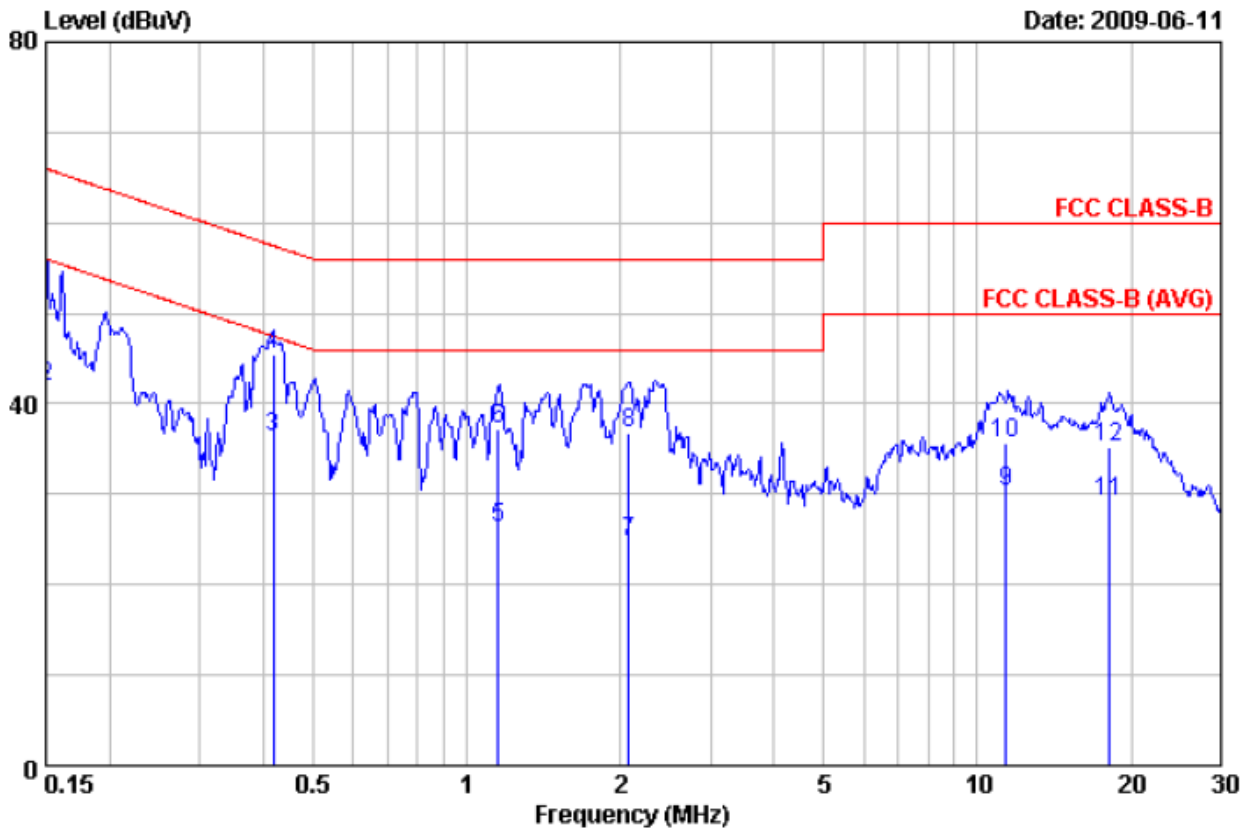

Item	Freq	Read Value	Factor	Result	Limit	Margin	Remark
	MHz	dBuV/m	dB	dBuV/m	dBuV/m	dB	
1	0.15	35.22	0.11	35.33	56.00	-20.67	Average
2	0.15	41.83	0.11	41.94	66.00	-24.06	QP
3	0.42	36.11	0.11	36.22	47.47	-11.25	Average
4	0.42	45.32	0.11	45.43	57.47	-12.04	QP
5	1.15	26.08	0.17	26.25	46.00	-19.75	Average
6	1.15	37.11	0.17	37.28	56.00	-18.72	QP
7	2.07	24.45	0.22	24.67	46.00	-21.33	Average
8	2.07	36.54	0.22	36.76	56.00	-19.24	QP
9	11.40	29.86	0.41	30.27	50.00	-19.73	Average
10	11.40	35.35	0.41	35.76	60.00	-24.24	QP
11	18.18	28.71	0.45	29.16	50.00	-20.84	Average
12	18.18	34.65	0.45	35.10	60.00	-24.90	QP



Power	: AC 120V	Pol/Phase	: NEUTRAL
Test Mode 1	: 802.11g CH1	Temperature	: 25 °C
Memo	: Adapter: MU12-G120100-A1	Humidity	: 55 %

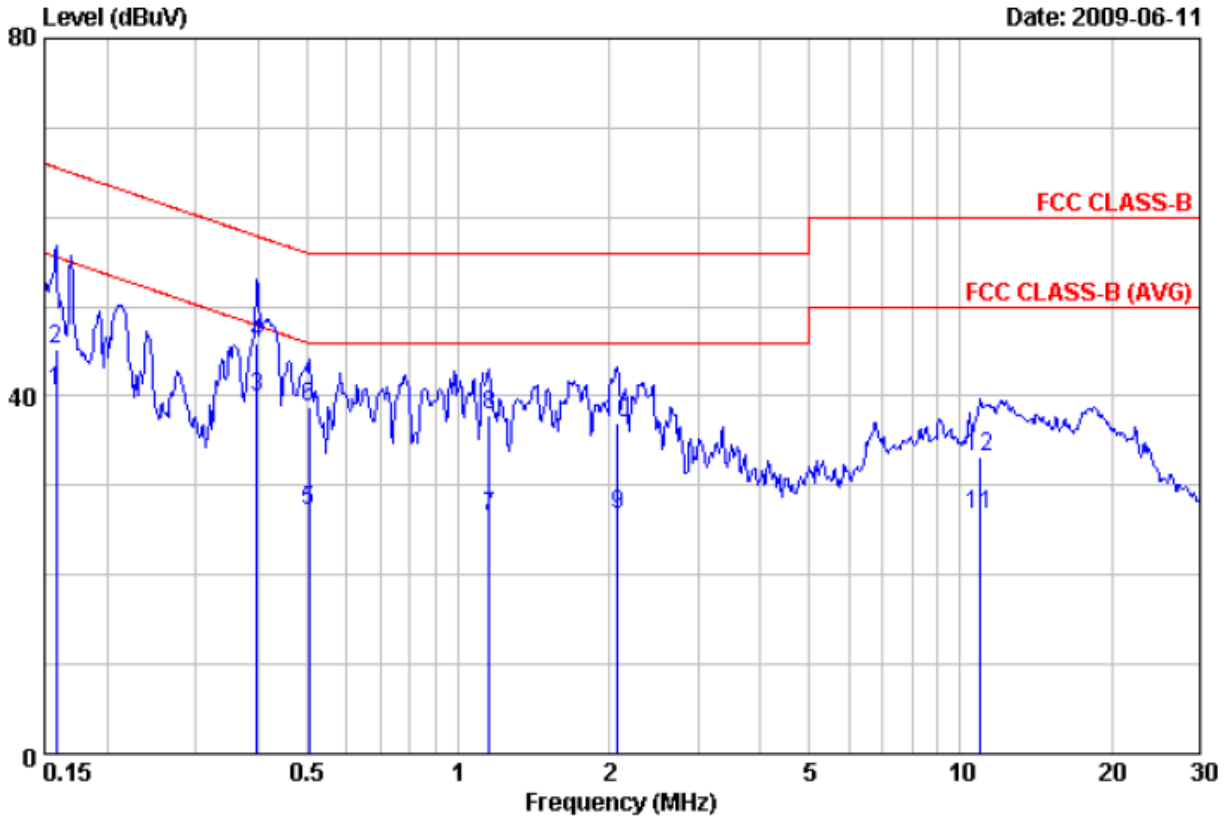

Item	Freq	Read Value	Factor	Result	Limit	Margin	Remark
	MHz	dBuV/m	dB	dBuV/m	dBuV/m	dB	
1	0.16	40.31	0.14	40.45	55.56	-15.11	Average
2	0.16	45.08	0.14	45.22	65.56	-20.34	QP
3	0.40	39.64	0.14	39.78	47.90	-8.12	Average
4	0.40	45.77	0.14	45.91	57.90	-11.99	QP
5	0.50	27.08	0.16	27.24	46.00	-18.76	Average
6	0.50	38.72	0.16	38.88	56.00	-17.12	QP
7	1.15	26.40	0.18	26.58	46.00	-19.42	Average
8	1.15	37.72	0.18	37.90	56.00	-18.10	QP
9	2.08	26.54	0.22	26.76	46.00	-19.24	Average
10	2.08	36.80	0.22	37.02	56.00	-18.98	QP
11	10.96	26.42	0.43	26.85	50.00	-23.15	Average
12	10.96	32.72	0.43	33.15	60.00	-26.85	QP



Power	: AC 120V	Pol/Phase	: LINE
Test Mode 2	: 802.11g CH1	Temperature	: 25 °C
Memo	: Adapter: RHN-120100-1-3	Humidity	: 55 %

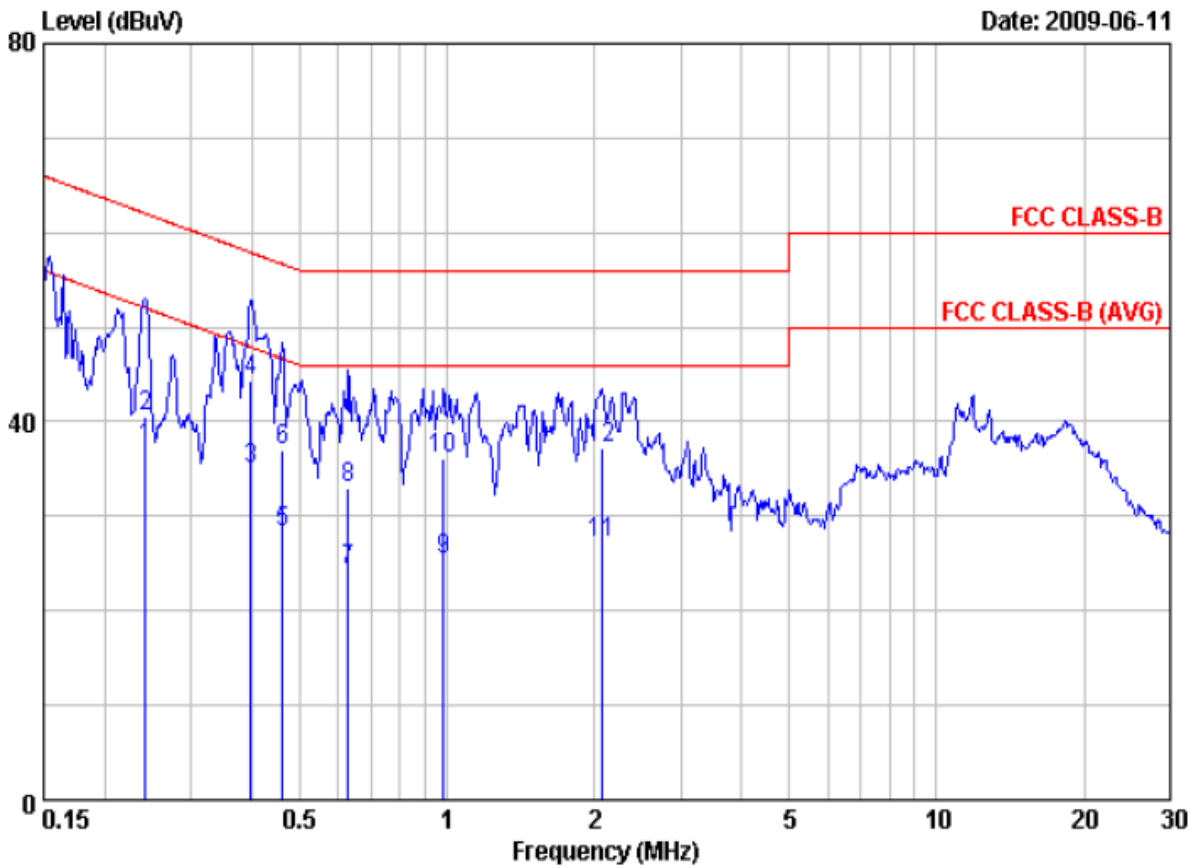

Item	Read Freq	Read Value	Factor	Result	Limit	Margin	Remark
	MHz	dBuV/m	dB	dBuV/m	dBuV/m	dB	
1	0.24	37.12	0.11	37.23	52.04	-14.81	Average
2	0.24	40.50	0.11	40.61	62.04	-21.43	QP
3	0.40	34.89	0.11	35.00	47.90	-12.90	Average
4	0.40	44.31	0.11	44.42	57.90	-13.48	QP
5	0.46	28.29	0.11	28.40	46.67	-18.27	Average
6	0.46	36.99	0.11	37.10	56.67	-19.57	QP
7	0.63	24.24	0.13	24.37	46.00	-21.63	Average
8	0.63	32.91	0.13	33.04	56.00	-22.96	QP
9	0.98	25.33	0.16	25.49	46.00	-20.51	Average
10	0.98	35.84	0.16	36.00	56.00	-20.00	QP
11	2.07	26.87	0.22	27.09	46.00	-18.91	Average
12	2.07	36.95	0.22	37.17	56.00	-18.83	QP



Power	: AC 120V	Pol/Phase	: NEUTRAL
Test Mode 2	: 802.11g CH1	Temperature	: 25 °C
Memo	: Adapter: RHN-120100-1-3	Humidity	: 55 %

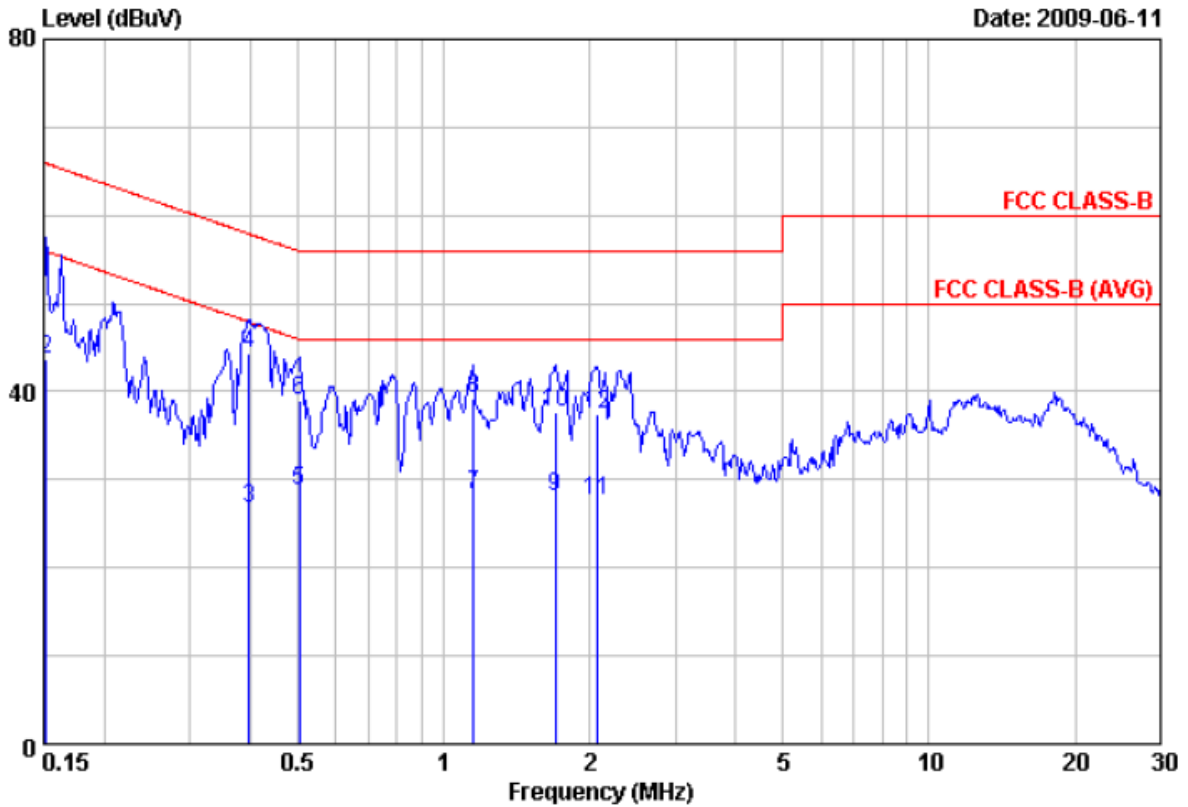

Item	Freq	Read Value	Factor	Result	Limit	Margin	Remark
	MHz	dBuV/m	dB	dBuV/m	dBuV/m	dB	
1	0.15	33.40	0.14	33.54	55.91	-22.37	Average
2	0.15	43.62	0.14	43.76	65.91	-22.15	QP
3	0.40	26.66	0.14	26.80	47.90	-21.10	Average
4	0.40	44.25	0.14	44.39	57.90	-13.51	QP
5	0.50	28.57	0.16	28.73	46.00	-17.27	Average
6	0.50	38.79	0.16	38.95	56.00	-17.05	QP
7	1.15	28.09	0.18	28.27	46.00	-17.73	Average
8	1.15	39.05	0.18	39.23	56.00	-16.77	QP
9	1.70	27.94	0.22	28.16	46.00	-17.84	Average
10	1.70	37.34	0.22	37.56	56.00	-18.44	QP
11	2.07	27.51	0.22	27.73	46.00	-18.27	Average
12	2.07	37.20	0.22	37.42	56.00	-18.58	QP

Test engineer: Ben



5. Test of Radiated Emission

5.1 Test Limit

Radiated emissions from 30 MHz to 25 GHz were measured according to the methods defines in ANSI C63.4-2003. The EUT was placed, 0.8 meter above the ground plane, as shown in section 5.6.3. The interface cables and equipment positions were varied within limits of reasonable applications to determine the positions producing maximum radiated emissions

For unintentional device, according to § 15.109(a), except for Class A digital devices, the field strength of radiated emissions from unintentional radiators at a distance of 3 meters shall not exceed the following values:

Frequency (MHz)	Distance Meters	Radiated (μ V / M)	Radiated (dB μ V/ M)
30-88	3	100	40.0
88-216	3	150	43.5
216-960	3	200	46.0
Above 960	3	500	54.0

For unintentional device, according to CISPR PUB.22, for Class B digital devices, the general requirement of field strength of radiated emissions from intentional radiators at a distance of 10 meters shall not exceed the below table.

Frequency (MHz)	Distance Meters	Radiated (dB μ V/ M)
30-230	10	30
230-1000	10	37

5.2 Test Procedures

- The EUT was placed on a rotatable table top 0.8 meter above ground.
- The EUT was set 3 meters from the interference receiving antenna which was mounted on the top of a variable height antenna tower.
- The table was rotated 360 degrees to determine the position of the highest radiation.
- The antenna is a broadband antenna and its height is varied between one meter and four meters above ground to find the maximum value of the field strength both horizontal polarization and vertical polarization of the antenna are set to make the measurement.
- For each suspected emission the EUT was arranged to its worst case and then tune the antenna tower (from 1 M to 4 M) and turn table (from 0 degree to 360 degrees) to find the maximum reading.
- Set the test-receiver system to Peak or CISPR quasi-peak Detect Function and specified bandwidth with Maximum Hold Mode.
- If the emission level of the EUT in peak mode was 3 dB lower than the limit specified, then testing will be stopped and peak values of EUT will be reported, otherwise, the emissions which do not have 3 dB margin will be repeated one by one using the quasi-peak method and reported.
- For testing above 1GHz, the emission level of the EUT in peak mode was 20dB lower than average limit (that means the emission level in peak mode also complies with the limit in average mode), then testing will be stopped and peak values of EUT will be reported, otherwise, the emissions will be measured in average mode again and reported.
- “Cone of radiation” has been considered to be 3dB beamwidth of the measurement antenna.



5.3 Typical Test Setup

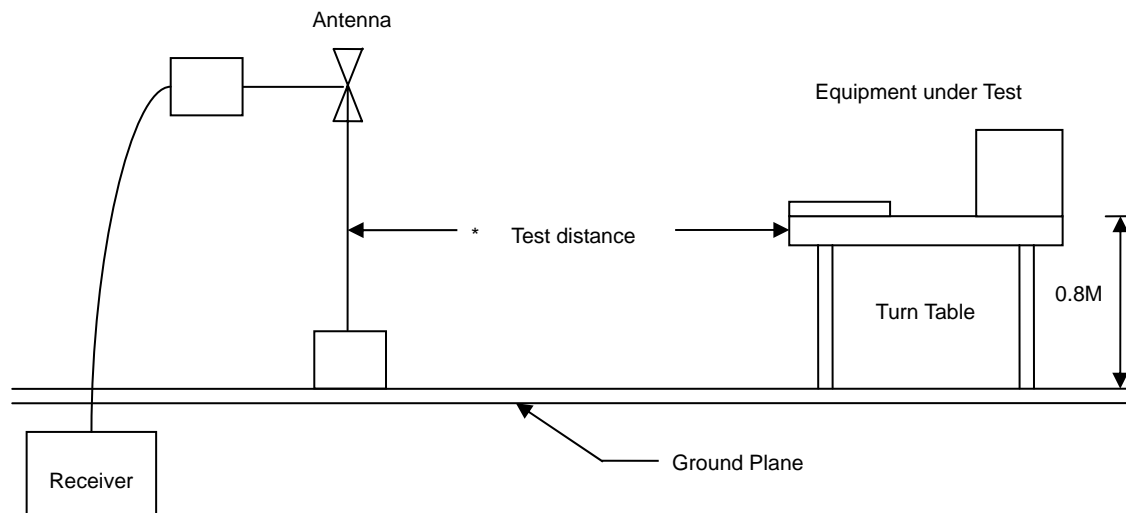

5.4 Measurement equipment

Instrument/Ancillary	Manufacturer	Model No.	Serial No.	Calibration Date	Valid Date
Bilog Antenna	Schaffner	CBL6112B	2840	2009/05/14	2010/05/13
Signal Generator	HP	8648B	3629U00612	2008/10/08	2009/10/07
Amplifier	Agilent	8447D	2944A10593	2009/05/21	2010/05/20
EMI Receiver	HP	8546A	3807A00454	2008/08/07	2009/08/06
Spectrum Analyzer	R&S	FSP40	100047	2009/03/26	2010/03/25
Horn Antenna	EMCO	3115	31589	2009/05/04	2010/05/03
Preamplifier	Agilent	8449B	3008A01954	2009/02/27	2010/02/26



5.5 Test Result and Data

Power	: AC 120V	Pol/Phase	: VERTICAL
Test Mode	: Transmit / Receive	Temperature	: 26 °C
Operation Channel	: 1	Humidity	: 68 %
Modulation Type	: 802.11g	Atmospheric Pressure	: 1021 hPa
Memo	: Adapter:MU12-G120100-A1	Rate	: 54 Mbps

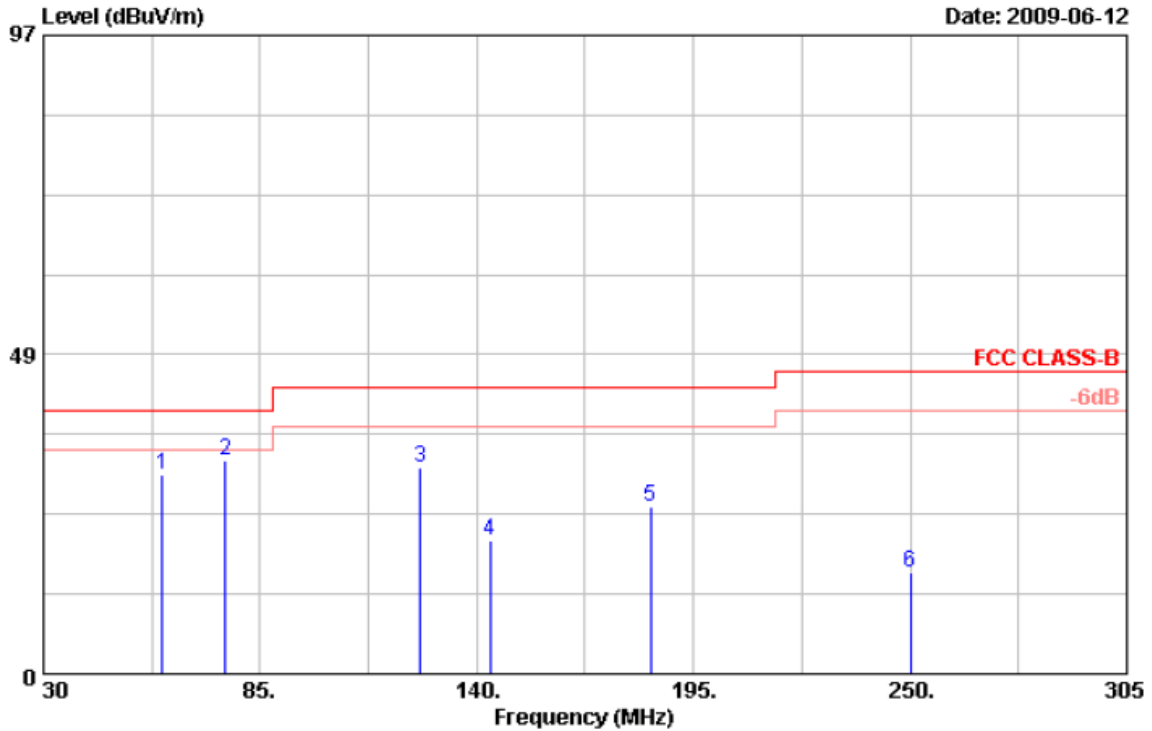

Item	Freq	Read Value	Factor	Result	Limit	Margin	Remark	Ant Pos	Tab Pos
	MHz	dBUV/m	dB	dBUV/m	dBUV/m	dB		cm	Deg
1	60.25	43.18	-12.85	30.33	40.00	-9.67	Peak	100	360
2	76.20	47.49	-15.16	32.33	40.00	-7.67	Peak	100	360
3	125.70	40.64	-9.31	31.33	43.50	-12.17	Peak	100	360
4	143.30	31.54	-11.17	20.37	43.50	-23.13	Peak	100	360
5	184.00	36.08	-10.71	25.37	43.50	-18.13	Peak	100	360
6	250.00	27.97	-12.64	15.33	46.00	-30.67	Peak	100	360

Notes:

1. Result = Read Value + Factor
2. Factor = Antenna Factor + Cable Loss - Amplifier
3. The resolution bandwidth of test receiver/spectrum analyzer is 120KHz and video bandwidth is 300kHz for Peak detection and Quasi-peak detection at frequency below 1GHz.
4. All emission below 1GHz at 802.11b/g mode are all the same,so the 802.11g mode chosen as representative in final test.
5. According to technical experiences,all spurious emission of 802.11g mode at channel 1,6,11 are almost the same below 1GHz,so that the channel 1 was chosen as representative in final test.
6. The data is worse case.



Power	: AC 120V	Pol/Phase	: VERTICAL
Test Mode	: Transmit / Receive	Temperature	: 26 °C
Operation Channel	: 1	Humidity	: 68 %
Modulation Type	: 802.11g	Atmospheric Pressure	: 1021 hPa
Memo	: Adapter:MU12-G120100-A1	Rate	: 54 Mbps

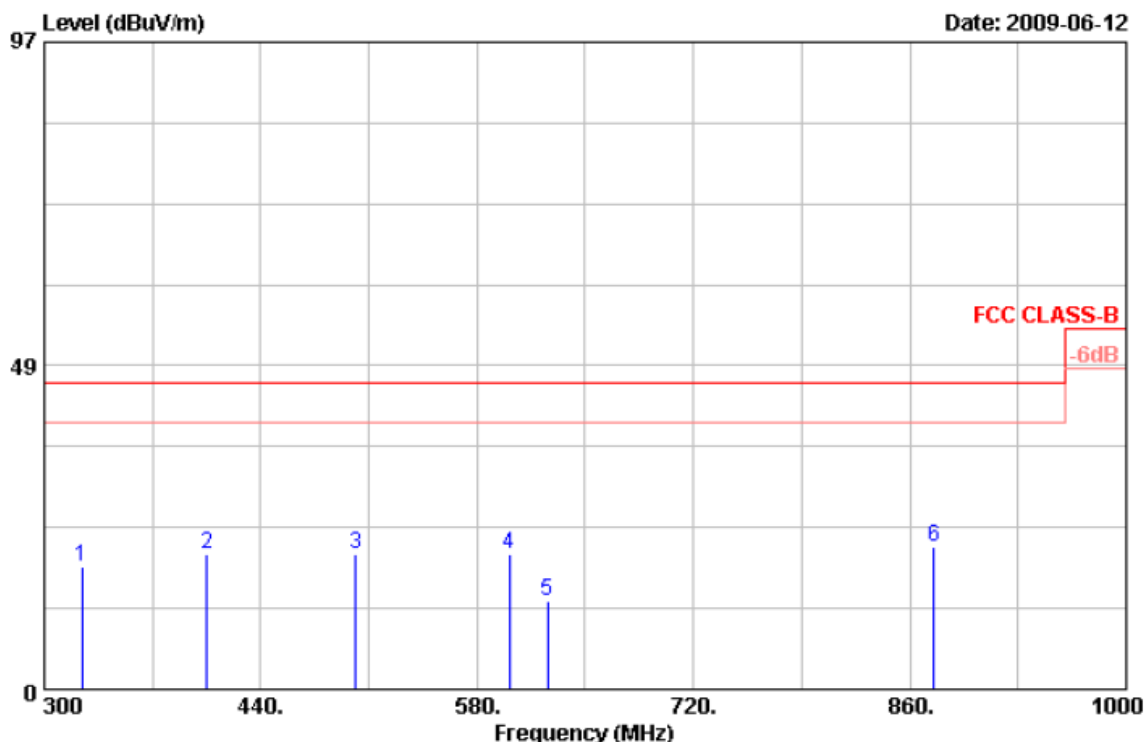

Item	Freq	Read Value	Factor	Result	Limit	Margin	Remark	Ant Pos	Tab Pos
	MHz	dBuV/m	dB	dBuV/m	dBuV/m	dB		cm	Deg
1	324.50	28.11	-9.78	18.33	46.00	-27.67	Peak	150	359
2	405.00	27.15	-6.82	20.33	46.00	-25.67	Peak	150	359
3	501.60	28.77	-8.44	20.33	46.00	-25.67	Peak	150	359
4	601.00	25.23	-4.99	20.24	46.00	-25.76	Peak	150	359
5	625.50	19.84	-6.52	13.32	46.00	-32.68	Peak	150	359
6	875.40	20.49	0.75	21.24	46.00	-24.76	Peak	150	359

Notes:

1. Result = Read Value + Factor
2. Factor = Antenna Factor + Cable Loss - Amplifier
3. The resolution bandwidth of test receiver/spectrum analyzer is 120KHz and video bandwidth is 300kHz for Peak detection and Quasi-peak detection at frequency below 1GHz.
4. All emission below 1GHz at 802.11g mode are all the same,so the 802.11g mode chosen as representative in final test.
5. According to technical experiences,all spurious emission of 802.11g mode at channel 1,6,11 are almost the same below 1GHz,so that the channel 1 was chosen as representative in final test.
6. The data is worse case.



Power	: AC 120V	Pol/Phase	: HORIZONTAL
Test Mode	: Transmit / Receive	Temperature	: 26 °C
Operation Channel	: 1	Humidity	: 68 %
Modulation Type	: 802.11g	Atmospheric Pressure	: 1021 hPa
Memo	: Adapter:MU12-G120100-A1	Rate	: 54 Mbps

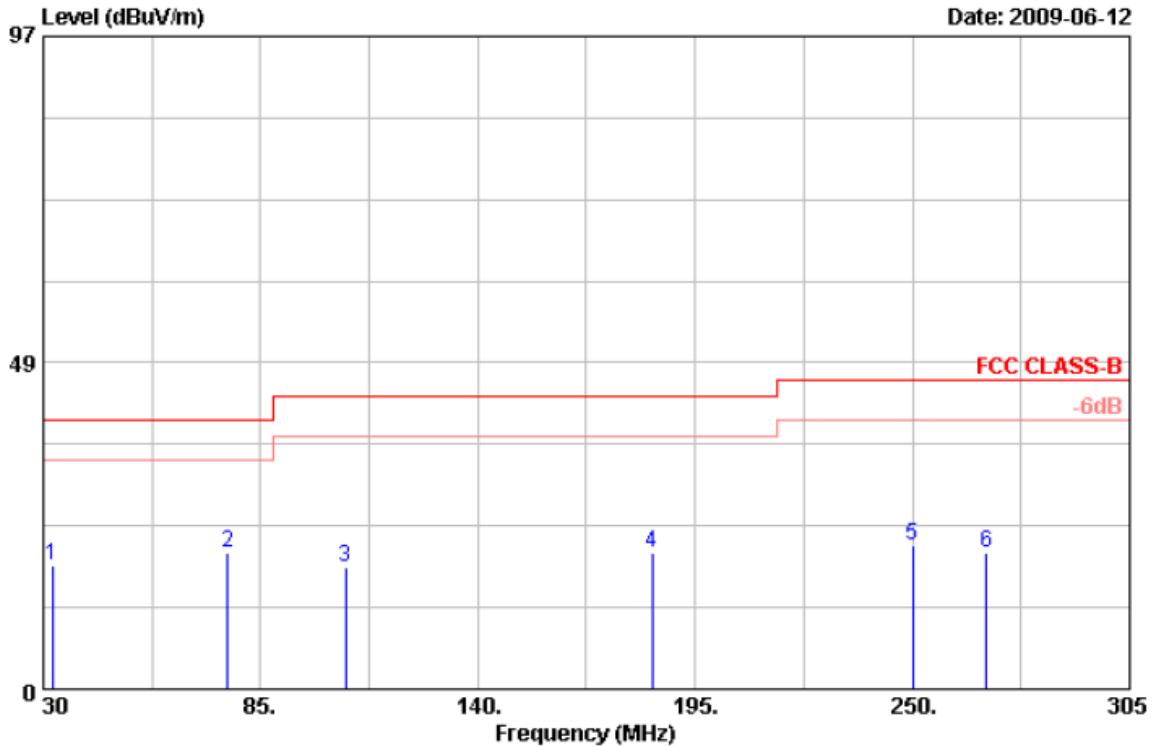

Item	Freq	Read Value	Factor	Result	Limit	Margin	Remark	Ant Pos	Tab Pos
	MHz	dBuV/m	dB	dBuV/m	dBuV/m	dB		cm	Deg
1	32.20	29.65	-11.39	18.26	40.00	-21.74	Peak	100	360
2	76.75	42.23	-21.90	20.33	40.00	-19.67	Peak	100	360
3	106.45	36.43	-18.20	18.23	43.50	-25.27	Peak	100	360
4	184.00	37.59	-17.35	20.24	43.50	-23.26	Peak	100	360
5	250.00	36.54	-15.28	21.26	46.00	-24.74	Peak	100	360
6	268.70	33.69	-13.36	20.33	46.00	-25.67	Peak	100	360

Notes:

1. Result = Read Value + Factor
2. Factor = Antenna Factor + Cable Loss - Amplifier
3. The resolution bandwidth of test receiver/spectrum analyzer is 120KHz and video bandwidth is 300kHz for Peak detection and Quasi-peak detection at frequency below 1GHz.
4. All emission below 1GHz at 802.11b/g mode are all the same,so the 802.11g mode chosen as representative in final test.
5. According to technical experiences,all spurious emission of 802.11g mode at channel 1,6,11 are almost the same below 1GHz,so that the channel 1 was chosen as representative in final test.
6. The data is worse case.



Power	: AC 120V	Pol/Phase	: HORIZONTAL
Test Mode	: Transmit / Receive	Temperature	: 26 °C
Operation Channel	: 1	Humidity	: 68 %
Modulation Type	: 802.11g	Atmospheric Pressure	: 1021 hPa
Memo	: Adapter:MU12-G120100-A1	Rate	: 54 Mbps

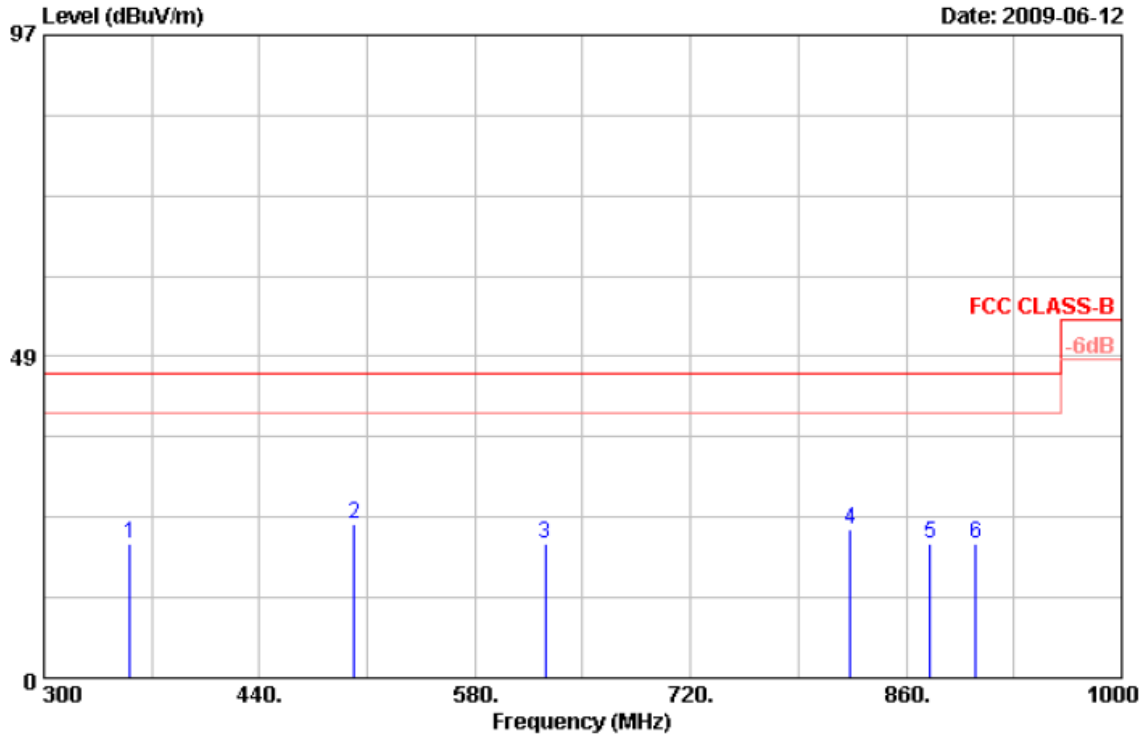

Item	Freq	Read Value	Factor	Result	Limit	Margin	Remark	Ant Pos	Tab Pos
	MHz	dBuV/m	dB	dBuV/m	dBuV/m	dB		cm	Deg
1	356.00	31.34	-11.11	20.23	46.00	-25.77	Peak	150	360
2	501.60	28.75	-5.42	23.33	46.00	-22.67	Peak	150	360
3	625.50	21.71	-1.45	20.26	46.00	-25.74	Peak	150	360
4	823.60	21.11	1.22	22.33	46.00	-23.67	Peak	150	360
5	875.40	20.17	0.06	20.23	46.00	-25.77	Peak	150	360
6	905.50	17.96	2.28	20.24	46.00	-25.76	Peak	150	360

Notes:

1. Result = Read Value + Factor
2. Factor = Antenna Factor + Cable Loss - Amplifier
3. The resolution bandwidth of test receiver/spectrum analyzer is 120KHz and video bandwidth is 300kHz for Peak detection and Quasi-peak detection at frequency below 1GHz.
4. All emission below 1GHz at 802.11b/g mode are all the same, so the 802.11g mode chosen as representative in final test.
5. According to technical experiences, all spurious emission of 802.11g mode at channel 1, 6, 11 are almost the same below 1GHz, so that the channel 1 was chosen as representative in final test.
6. The data is worse case.



Power	: AC 120V	Pol/Phase	: VERTICAL
Test Mode	: Transmit / Receive	Temperature	: 26 °C
Operation Channel	: 1	Humidity	: 68 %
Modulation Type	: 802.11b	Atmospheric Pressure	: 1018 hPa
Memo	: Adapter:MU12-G120100-A1	Rate	: 11 Mbps

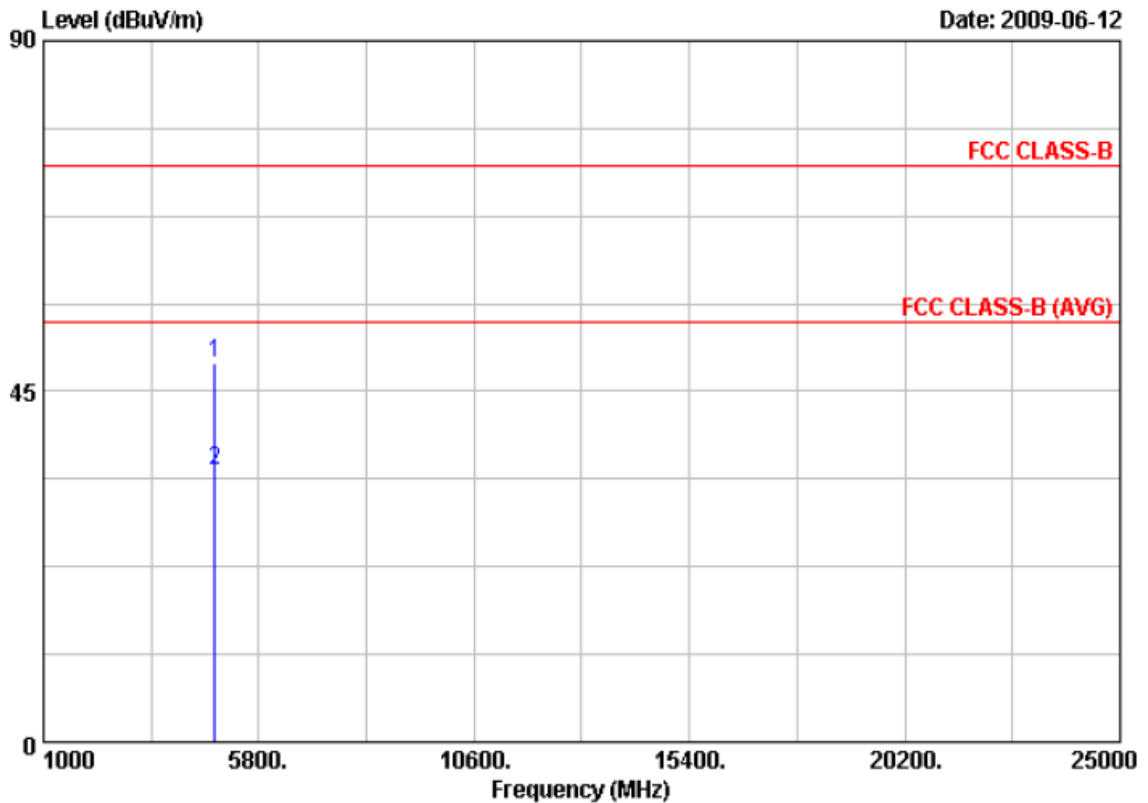

Item	Freq	Read Value	Factor	Result	Limit	Margin	Remark	Ant Pos	Tab Pos
	MHz	dBuV/m	dB	dBuV/m	dBuV/m	dB		cm	Deg
1	4820.52	46.13	2.55	48.68	74.00	-25.32	Peak	100	0
2	4826.73	32.28	2.57	34.85	54.00	-19.15	Average	100	0

Notes:

1. Result = Read Value + Factor
2. Factor = Antenna Factor + Cable Loss - Amplifier
3. The resolution bandwidth of test receiver/spectrum analyzer is 120KHz and video bandwidth is 300kHz for Peak detection and Quasi-peak detection at frequency below 1GHz.
4. The resolution bandwidth of test receiver/spectrum analyzer is 1MHz and video bandwidth is 3MHz for Peak detection at frequency above 1GHz.
5. The resolution bandwidth of test receiver/spectrum analyzer is 1MHz and video bandwidth is 10Hz for Average detection at frequency above 1GHz.
6. The other emissions is too low to be measured.



Power	: AC 120V	Pol/Phase	: HORIZONTAL
Test Mode	: Transmit / Receive	Temperature	: 26 °C
Operation Channel	: 1	Humidity	: 68 %
Modulation Type	: 802.11b	Atmospheric Pressure	: 1018 hPa
Memo	: Adapter:MU12-G120100-A1	Rate	: 11 Mbps

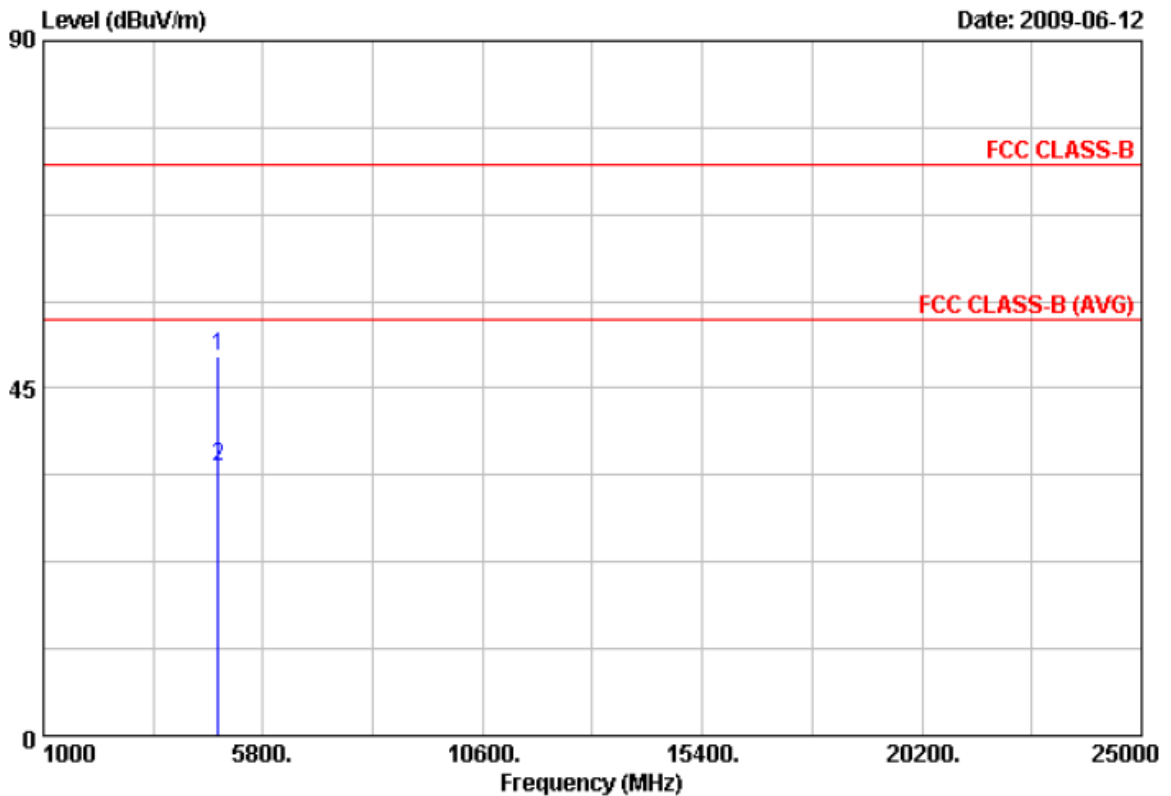

Item	Freq	Read Value	Factor	Result	Limit	Margin	Remark	Ant Pos	Tab Pos
	MHz	dBuV/m	dB	dBuV/m	dBuV/m	dB		cm	Deg
1	4822.48	46.47	2.55	49.02	74.00	-24.98	Peak	100	0
2	4826.66	32.31	2.57	34.88	54.00	-19.12	Average	100	0

Notes:

1. Result = Read Value + Factor
2. Factor = Antenna Factor + Cable Loss - Amplifier
3. The resolution bandwidth of test receiver/spectrum analyzer is 120KHz and video bandwidth is 300KHz for Peak detection and Quasi-peak detection at frequency below 1GHz.
4. The resolution bandwidth of test receiver/spectrum analyzer is 1MHz and video bandwidth is 3MHz for Peak detection at frequency above 1GHz.
5. The resolution bandwidth of test receiver/spectrum analyzer is 1MHz and video bandwidth is 10Hz for Average detection at frequency above 1GHz.
6. The other emissions is too low to be measured.



Power	: AC 120V	Pol/Phase	: VERTICAL
Test Mode	: Transmit / Receive	Temperature	: 26 °C
Operation Channel	: 6	Humidity	: 68 %
Modulation Type	: 802.11b	Atmospheric Pressure	: 1018 hPa
Memo	: Adapter:MU12-G120100-A1	Rate	: 11 Mbps

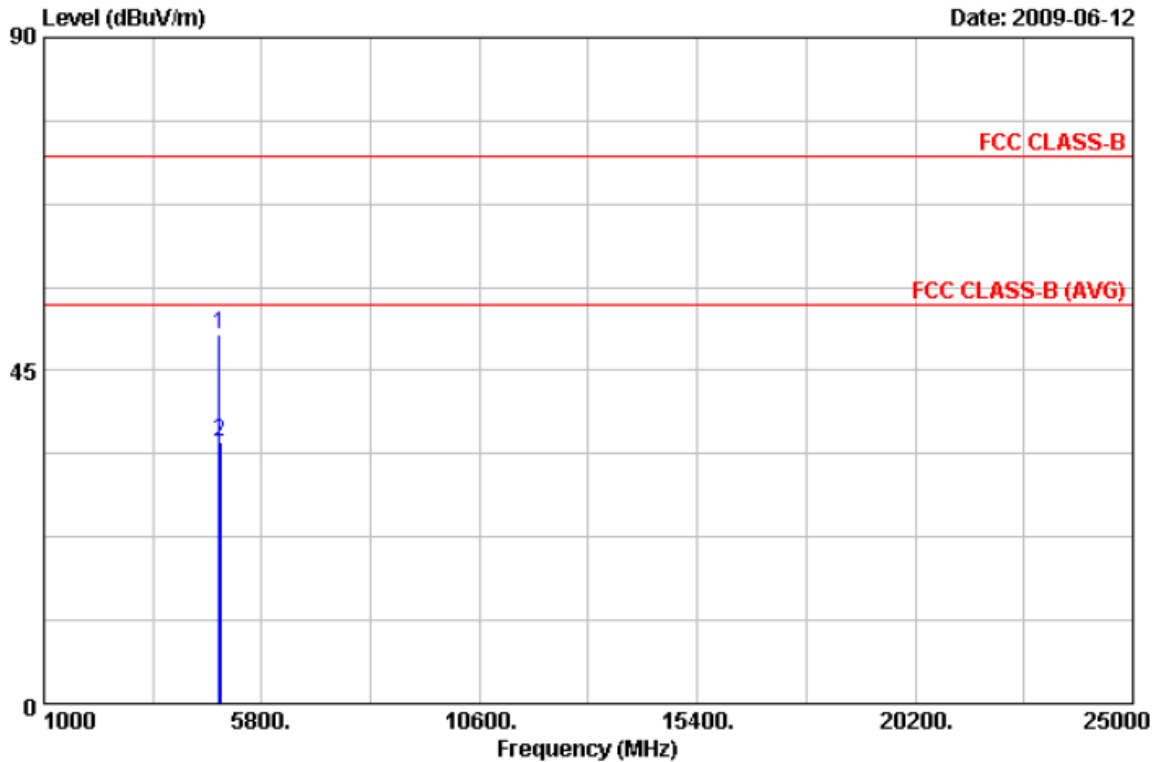

Item	Freq	Read Value	Factor	Result	Limit	Margin	Remark	Ant Pos	Tab Pos
	MHz	dBuV/m	dB	dBuV/m	dBuV/m	dB		cm	Deg
1	4869.40	47.14	2.67	49.81	74.00	-24.19	Peak	100	0
2	4876.42	32.63	2.71	35.34	54.00	-18.66	Average	100	0

Notes:

1. Result = Read Value + Factor
2. Factor = Antenna Factor + Cable Loss - Amplifier
3. The resolution bandwidth of test receiver/spectrum analyzer is 120KHz and video bandwidth is 300kHz for Peak detection and Quasi-peak detection at frequency below 1GHz.
4. The resolution bandwidth of test receiver/spectrum analyzer is 1MHz and video bandwidth is 3MHz for Peak detection at frequency above 1GHz.
5. The resolution bandwidth of test receiver/spectrum analyzer is 1MHz and video bandwidth is 10Hz for Average detection at frequency above 1GHz.
6. The other emissions is too low to be measured.



Power	: AC 120V	Pol/Phase	: HORIZONTAL
Test Mode	: Transmit / Receive	Temperature	: 26 °C
Operation Channel	: 6	Humidity	: 68 %
Modulation Type	: 802.11b	Atmospheric Pressure	: 1018 hPa
Memo	: Adapter:MU12-G120100-A1	Rate	: 11 Mbps

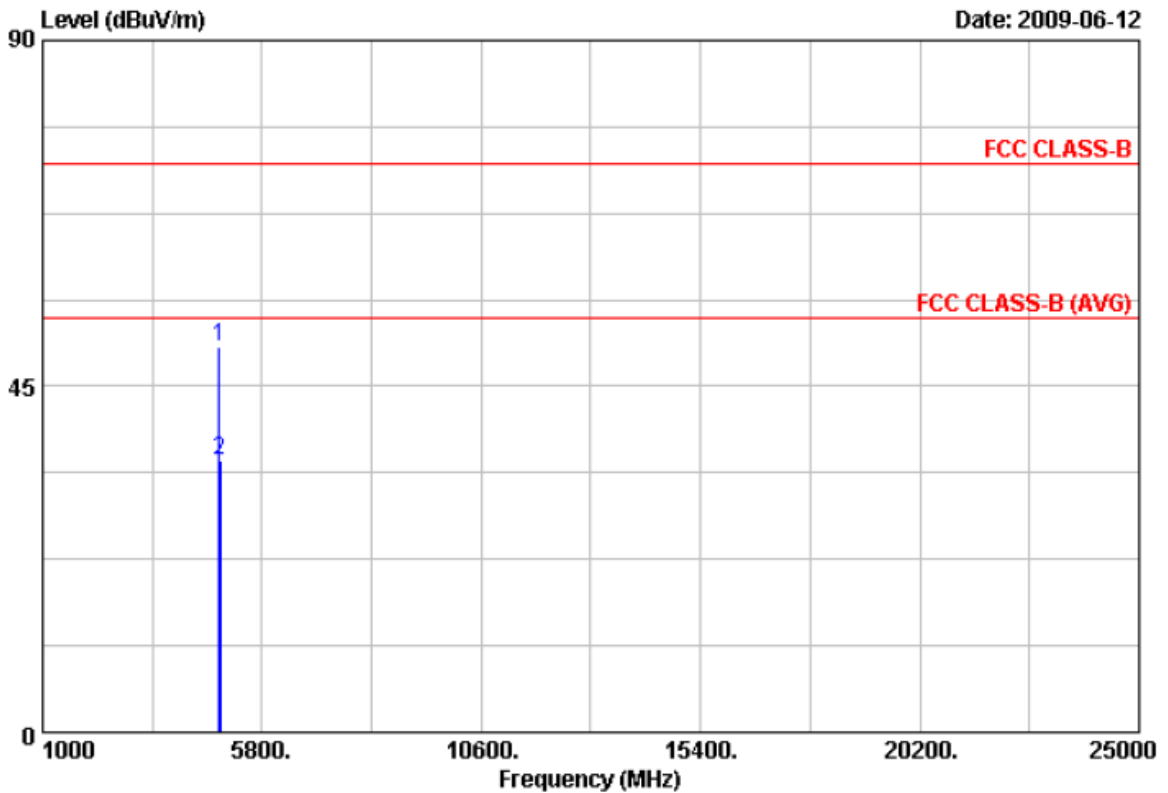

Item	Freq	Read Value	Factor	Result	Limit	Margin	Remark	Ant Pos	Tab Pos
	MHz	dBuV/m	dB	dBuV/m	dBuV/m	dB		cm	Deg
1	4872.70	47.38	2.68	50.06	74.00	-23.94	Peak	100	0
2	4878.70	32.64	2.71	35.35	54.00	-18.65	Average	100	0

Notes:

1. Result = Read Value + Factor
2. Factor = Antenna Factor + Cable Loss - Amplifier
3. The resolution bandwidth of test receiver/spectrum analyzer is 120KHz and video bandwidth is 300kHz for Peak detection and Quasi-peak detection at frequency below 1GHz.
4. The resolution bandwidth of test receiver/spectrum analyzer is 1MHz and video bandwidth is 3MHz for Peak detection at frequency above 1GHz.
5. The resolution bandwidth of test receiver/spectrum analyzer is 1MHz and video bandwidth is 10Hz for Average detection at frequency above 1GHz.
6. The other emissions is too low to be measured.



Power	: AC 120V	Pol/Phase	: VERTICAL
Test Mode	: Transmit / Receive	Temperature	: 26 °C
Operation Channel	: 11	Humidity	: 68 %
Modulation Type	: 802.11b	Atmospheric Pressure	: 1018 hPa
Memo	: Adapter:MU12-G120100-A1	Rate	: 11 Mbps

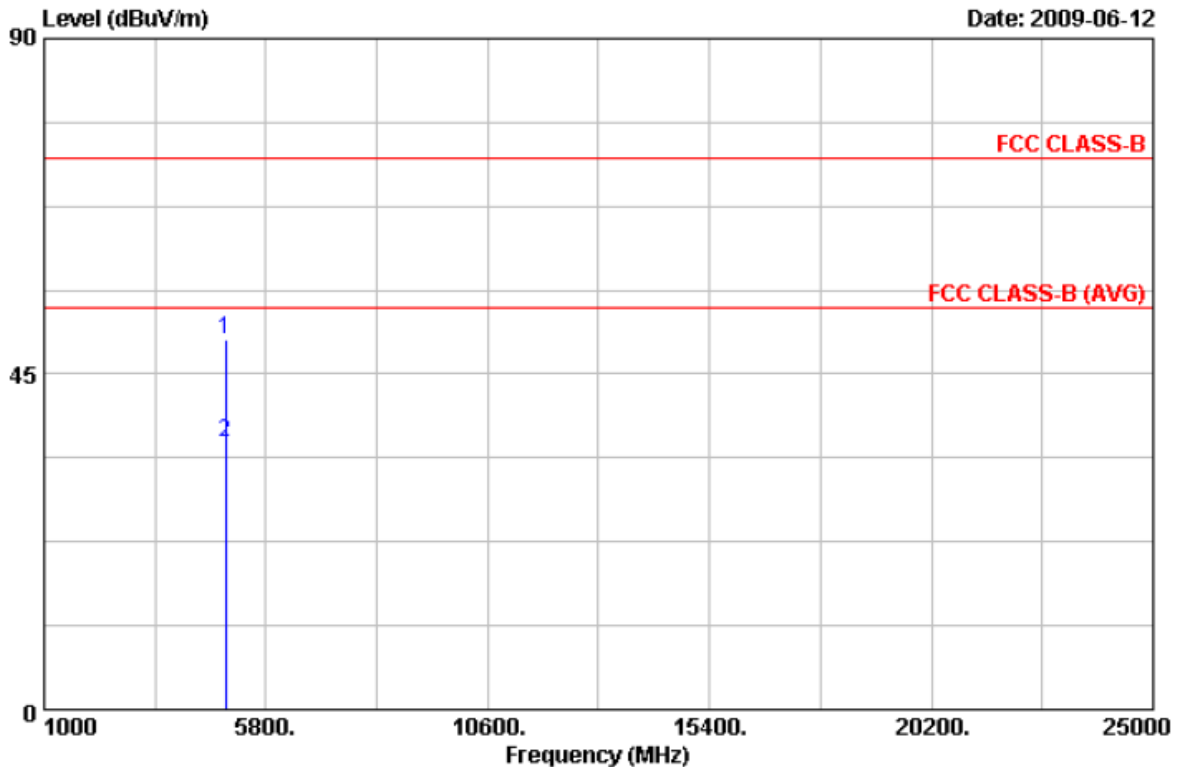

Item	Freq	Read Value	Factor	Result	Limit	Margin	Remark	Ant Pos	Tab Pos
	MHz	dBuV/m	dB	dBuV/m	dBuV/m	dB		cm	Deg
1	4924.40	46.91	2.82	49.73	74.00	-24.27	Peak	100	0
2	4928.22	32.98	2.84	35.82	54.00	-18.18	Average	100	0

Notes:

1. Result = Read Value + Factor
2. Factor = Antenna Factor + Cable Loss - Amplifier
3. The resolution bandwidth of test receiver/spectrum analyzer is 120KHz and video bandwidth is 300kHz for Peak detection and Quasi-peak detection at frequency below 1GHz.
4. The resolution bandwidth of test receiver/spectrum analyzer is 1MHz and video bandwidth is 3MHz for Peak detection at frequency above 1GHz.
5. The resolution bandwidth of test receiver/spectrum analyzer is 1MHz and video bandwidth is 10Hz for Average detection at frequency above 1GHz.
6. The other emissions is too low to be measured.



Power	: AC 120V	Pol/Phase	: HORIZONTAL
Test Mode	: Transmit / Receive	Temperature	: 26 °C
Operation Channel	: 11	Humidity	: 68 %
Modulation Type	: 802.11b	Atmospheric Pressure	: 1018 hPa
Memo	: Adapter:MU12-G120100-A1	Rate	: 11 Mbps

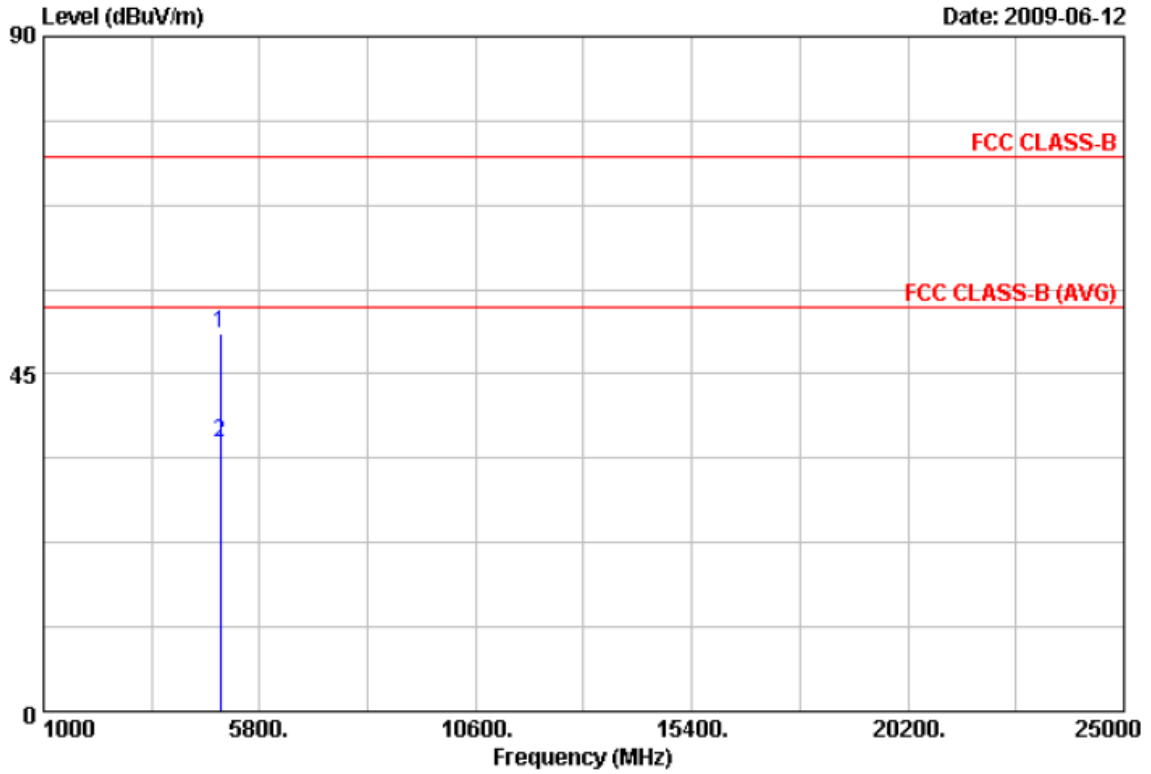

Item	Freq	Read Value	Factor	Result	Limit	Margin	Remark	Ant Pos	Tab Pos
	MHz	dBuV/m	dB	dBuV/m	dBuV/m	dB		cm	Deg
1	4923.75	47.45	2.82	50.27	74.00	-23.73	Peak	100	0
2	4928.46	32.95	2.84	35.79	54.00	-18.21	Average	100	0

Notes:

1. Result = Read Value + Factor
2. Factor = Antenna Factor + Cable Loss - Amplifier
3. The resolution bandwidth of test receiver/spectrum analyzer is 120KHz and video bandwidth is 300kHz for Peak detection and Quasi-peak detection at frequency below 1GHz.
4. The resolution bandwidth of test receiver/spectrum analyzer is 1MHz and video bandwidth is 3MHz for Peak detection at frequency above 1GHz.
5. The resolution bandwidth of test receiver/spectrum analyzer is 1MHz and video bandwidth is 10Hz for Average detection at frequency above 1GHz.
6. The other emissions is too low to be measured.



Power	: AC 120V	Pol/Phase	: VERTICAL
Test Mode	: Transmit / Receive	Temperature	: 26 °C
Operation Channel	: 1	Humidity	: 68 %
Modulation Type	: 802.11g	Atmospheric Pressure	: 1018 hPa
Memo	: Adapter:MU12-G120100-A1	Rate	: 54 Mbps

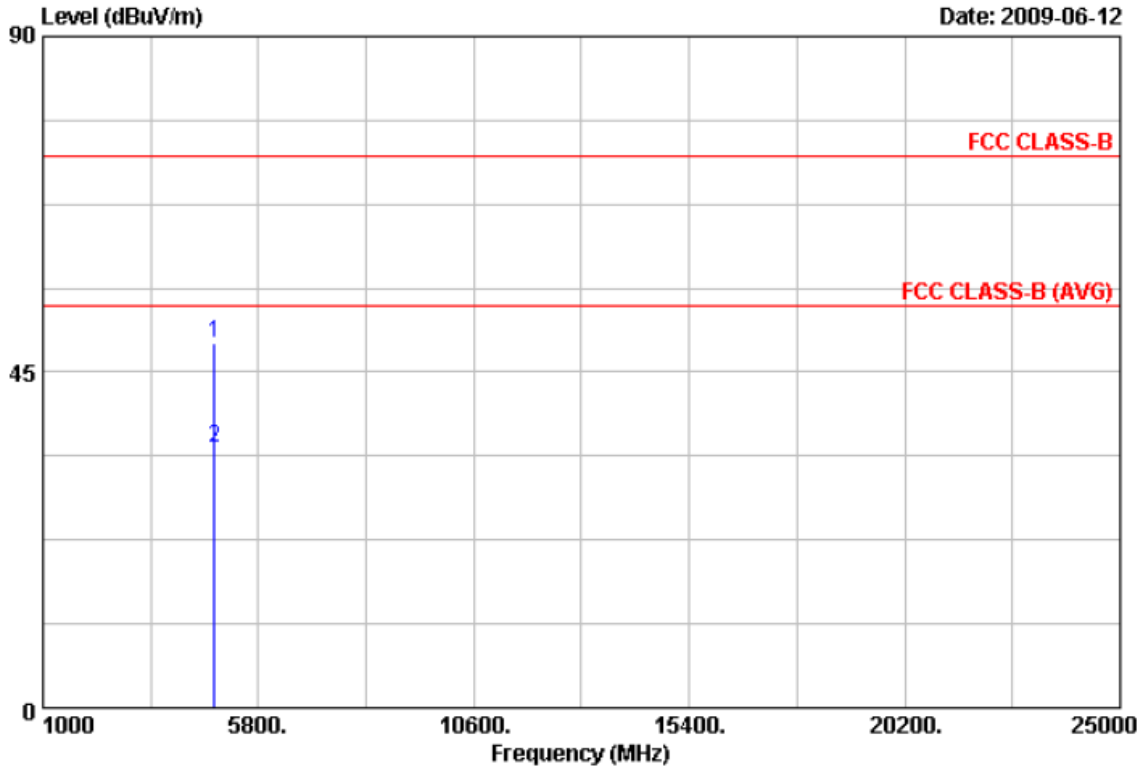

Item	Freq	Read Value	Factor	Result	Limit	Margin	Remark	Ant Pos	Tab Pos
	MHz	dBuV/m	dB	dBuV/m	dBuV/m	dB		cm	Deg
1	4824.49	46.39	2.55	48.94	74.00	-25.06	Peak	100	0
2	4826.72	32.22	2.57	34.79	54.00	-19.21	Average	100	0

Notes:

1. Result = Read Value + Factor
2. Factor = Antenna Factor + Cable Loss - Amplifier
3. The resolution bandwidth of test receiver/spectrum analyzer is 120KHz and video bandwidth is 300kHz for Peak detection and Quasi-peak detection at frequency below 1GHz.
4. The resolution bandwidth of test receiver/spectrum analyzer is 1MHz and video bandwidth is 3MHz for Peak detection at frequency above 1GHz.
5. The resolution bandwidth of test receiver/spectrum analyzer is 1MHz and video bandwidth is 10Hz for Average detection at frequency above 1GHz.
6. The other emissions is too low to be measured.



Power	: AC 120V	Pol/Phase	: HORIZONTAL
Test Mode	: Transmit / Receive	Temperature	: 26 °C
Operation Channel	: 1	Humidity	: 68 %
Modulation Type	: 802.11g	Atmospheric Pressure	: 1018 hPa
Memo	: Adapter:MU12-G120100-A1	Rate	: 54 Mbps

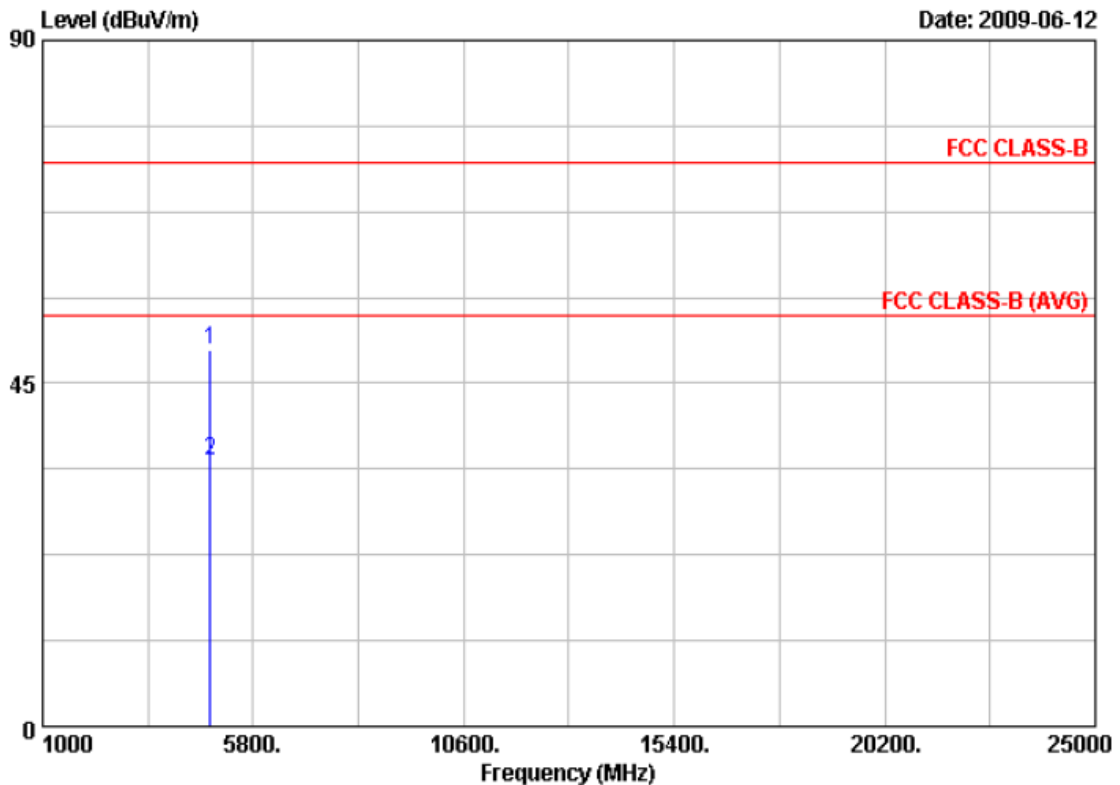

Item	Freq	Read Value	Factor	Result	Limit	Margin	Remark	Ant Pos	Tab Pos
	MHz	dBuV/m	dB	dBuV/m	dBuV/m	dB		cm	Deg
1	4826.39	46.84	2.57	49.41	74.00	-24.59	Peak	100	0
2	4826.52	32.19	2.57	34.76	54.00	-19.24	Average	100	0

Notes:

1. Result = Read Value + Factor
2. Factor = Antenna Factor + Cable Loss - Amplifier
3. The resolution bandwidth of test receiver/spectrum analyzer is 120KHz and video bandwidth is 300kHz for Peak detection and Quasi-peak detection at frequency below 1GHz.
4. The resolution bandwidth of test receiver/spectrum analyzer is 1MHz and video bandwidth is 3MHz for Peak detection at frequency above 1GHz.
5. The resolution bandwidth of test receiver/spectrum analyzer is 1MHz and video bandwidth is 10Hz for Average detection at frequency above 1GHz.
6. The other emissions is too low to be measured.



Power	: AC 120V	Pol/Phase	: VERTICAL
Test Mode	: Transmit / Receive	Temperature	: 26 °C
Operation Channel	: 6	Humidity	: 68 %
Modulation Type	: 802.11g	Atmospheric Pressure	: 1018 hPa
Memo	: Adapter:MU12-G120100-A1	Rate	: 54 Mbps

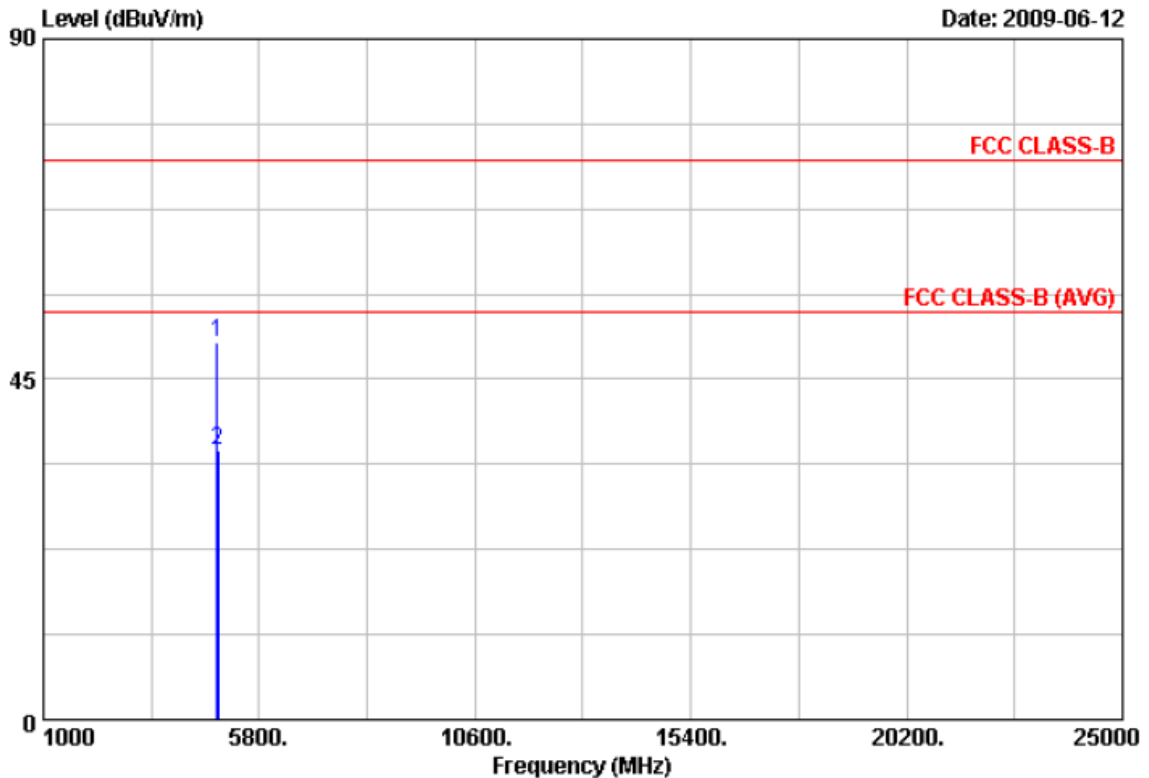

Item	Freq	Read Value	Factor	Result	Limit	Margin	Remark	Ant Pos	Tab Pos
	MHz	dBuV/m	dB	dBuV/m	dBuV/m	dB		cm	Deg
1	4869.63	47.10	2.68	49.78	74.00	-24.22	Peak	100	0
2	4884.06	32.93	2.72	35.65	54.00	-18.35	Average	100	0

Notes:

1. Result = Read Value + Factor
2. Factor = Antenna Factor + Cable Loss - Amplifier
3. The resolution bandwidth of test receiver/spectrum analyzer is 120KHz and video bandwidth is 300kHz for Peak detection and Quasi-peak detection at frequency below 1GHz.
4. The resolution bandwidth of test receiver/spectrum analyzer is 1MHz and video bandwidth is 3MHz for Peak detection at frequency above 1GHz.
5. The resolution bandwidth of test receiver/spectrum analyzer is 1MHz and video bandwidth is 10Hz for Average detection at frequency above 1GHz.
6. The other emissions is too low to be measured.



Power	: AC 120V	Pol/Phase	: HORIZONTAL
Test Mode	: Transmit / Receive	Temperature	: 26 °C
Operation Channel	: 6	Humidity	: 68 %
Modulation Type	: 802.11g	Atmospheric Pressure	: 1018 hPa
Memo	: Adapter:MU12-G120100-A1	Rate	: 54 Mbps

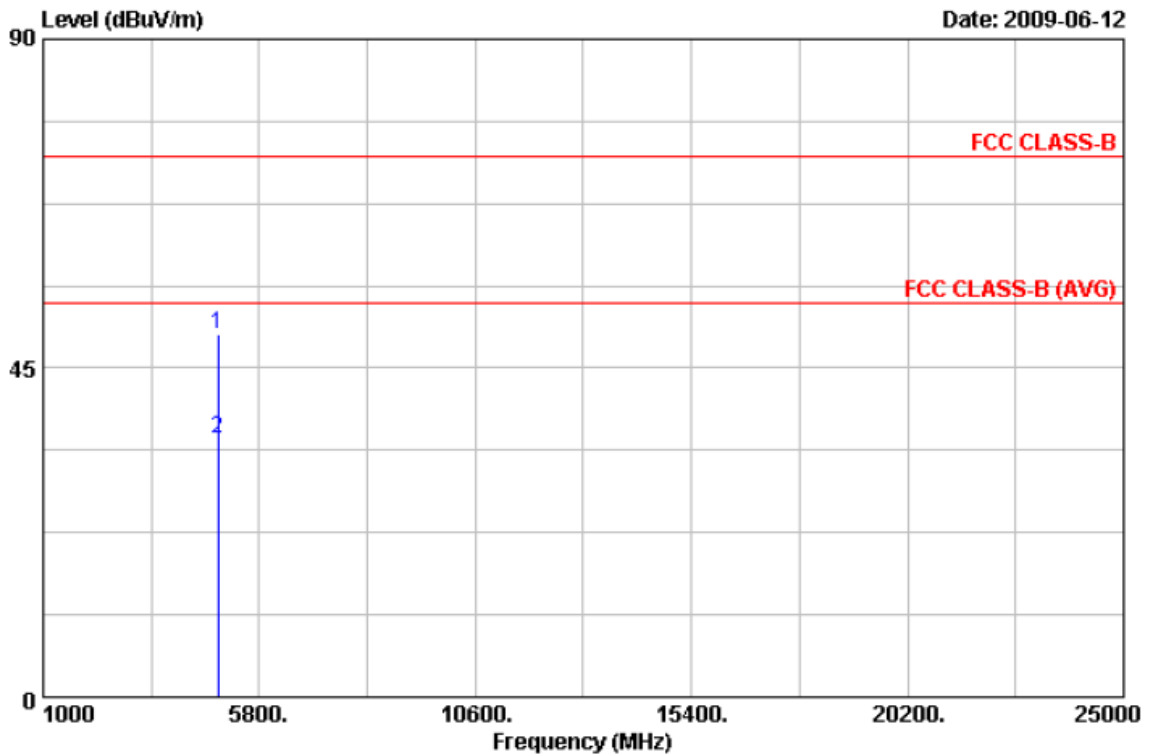

Item	Freq	Read Value	Factor	Result	Limit	Margin	Remark	Ant Pos	Tab Pos
	MHz	dBuV/m	dB	dBuV/m	dBuV/m	dB		cm	Deg
1	4873.48	46.86	2.69	49.55	74.00	-24.45	Peak	100	0
2	4878.96	32.64	2.71	35.35	54.00	-18.65	Average	100	0

Notes:

1. Result = Read Value + Factor
2. Factor = Antenna Factor + Cable Loss - Amplifier
3. The resolution bandwidth of test receiver/spectrum analyzer is 120KHz and video bandwidth is 300kHz for Peak detection and Quasi-peak detection at frequency below 1GHz.
4. The resolution bandwidth of test receiver/spectrum analyzer is 1MHz and video bandwidth is 3MHz for Peak detection at frequency above 1GHz.
5. The resolution bandwidth of test receiver/spectrum analyzer is 1MHz and video bandwidth is 10Hz for Average detection at frequency above 1GHz.
6. The other emissions is too low to be measured.



Power	: AC 120V	Pol/Phase	: VERTICAL
Test Mode	: Transmit / Receive	Temperature	: 26 °C
Operation Channel	: 11	Humidity	: 68 %
Modulation Type	: 802.11g	Atmospheric Pressure	: 1018 hPa
Memo	: Adapter:MU12-G120100-A1	Rate	: 54 Mbps

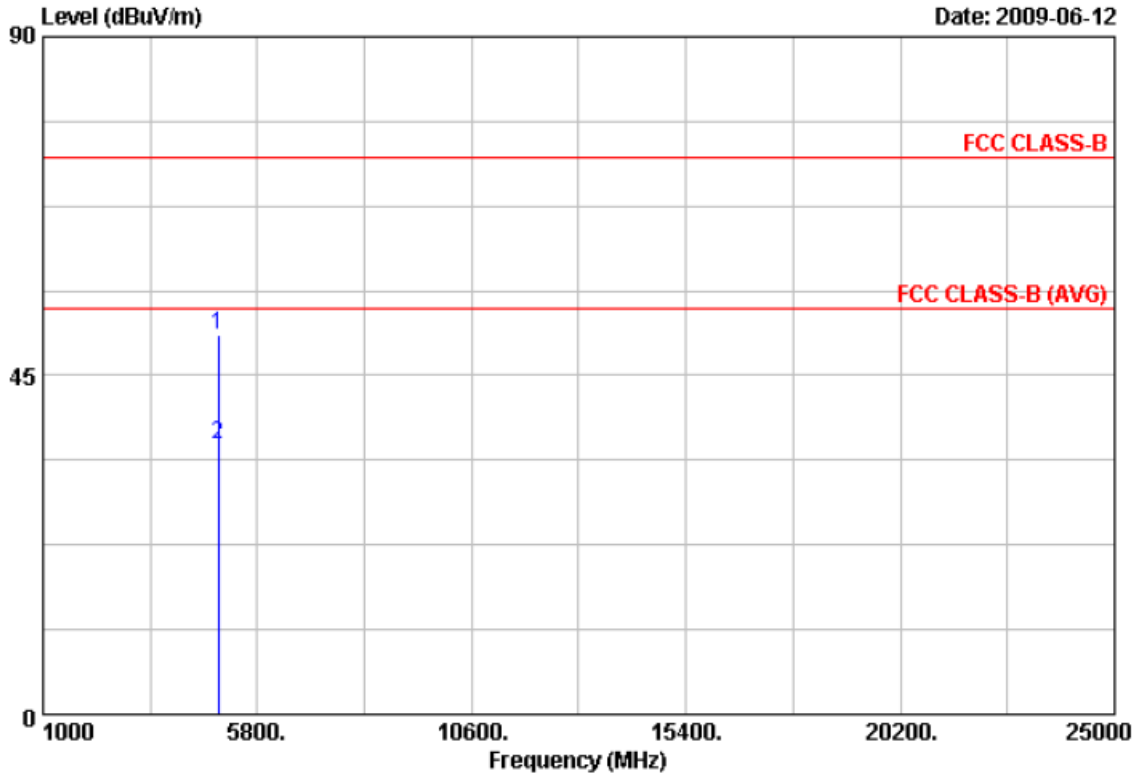

Item	Freq	Read Value	Factor	Result	Limit	Margin	Remark	Ant Pos	Tab Pos
	MHz	dBuV/m	dB	dBuV/m	dBuV/m	dB		cm	Deg
1	4922.73	47.53	2.82	50.35	74.00	-23.65	Peak	100	0
2	4928.46	32.92	2.84	35.76	54.00	-18.24	Average	100	0

Notes:

1. Result = Read Value + Factor
2. Factor = Antenna Factor + Cable Loss - Amplifier
3. The resolution bandwidth of test receiver/spectrum analyzer is 120KHz and video bandwidth is 300kHz for Peak detection and Quasi-peak detection at frequency below 1GHz.
4. The resolution bandwidth of test receiver/spectrum analyzer is 1MHz and video bandwidth is 3MHz for Peak detection at frequency above 1GHz.
5. The resolution bandwidth of test receiver/spectrum analyzer is 1MHz and video bandwidth is 10Hz for Average detection at frequency above 1GHz.
6. The other emissions is too low to be measured.



Power	: AC 120V	Pol/Phase	: HORIZONTAL
Test Mode	: Transmit / Receive	Temperature	: 26 °C
Operation Channel	: 11	Humidity	: 68 %
Modulation Type	: 802.11g	Atmospheric Pressure	: 1018 hPa
Memo	: Adapter:MU12-G120100-A1	Rate	: 54 Mbps

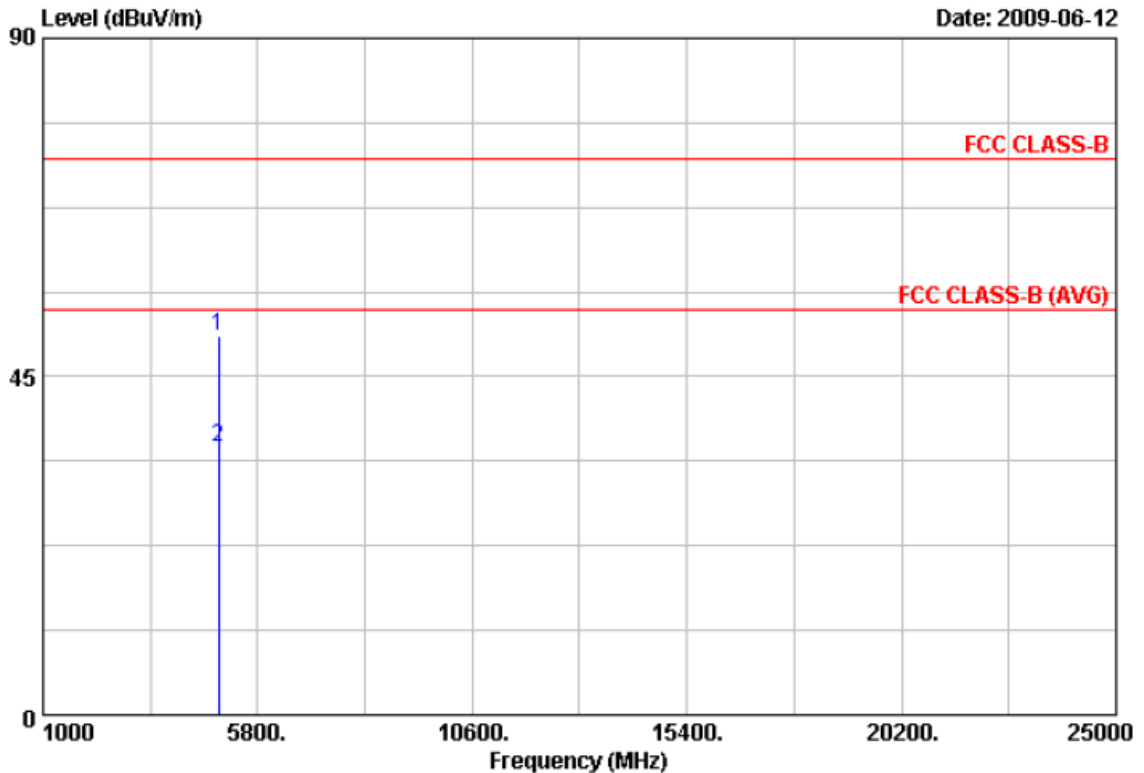

Item	Freq	Read Value	Factor	Result	Limit	Margin	Remark	Ant Pos	Tab Pos
	MHz	dBuV/m	dB	dBuV/m	dBuV/m	dB		cm	Deg
1	4919.47	47.51	2.82	50.33	74.00	-23.67	Peak	100	0
2	4928.42	32.88	2.84	35.72	54.00	-18.28	Average	100	0

Notes:

1. Result = Read Value + Factor
2. Factor = Antenna Factor + Cable Loss - Amplifier
3. The resolution bandwidth of test receiver/spectrum analyzer is 120KHz and video bandwidth is 300kHz for Peak detection and Quasi-peak detection at frequency below 1GHz.
4. The resolution bandwidth of test receiver/spectrum analyzer is 1MHz and video bandwidth is 3MHz for Peak detection at frequency above 1GHz.
5. The resolution bandwidth of test receiver/spectrum analyzer is 1MHz and video bandwidth is 10Hz for Average detection at frequency above 1GHz.
6. The other emissions is too low to be measured.



Power	: AC 120V	Pol/Phase	: VERTICAL
Test Mode	: Transmit / Receive	Temperature	: 26 °C
Operation Channel	: 1	Humidity	: 68 %
Modulation Type	: 802.11g	Atmospheric Pressure	: 1021 hPa
Memo	: Adapter: RHN-120100-1-3	Rate	: 54 Mbps

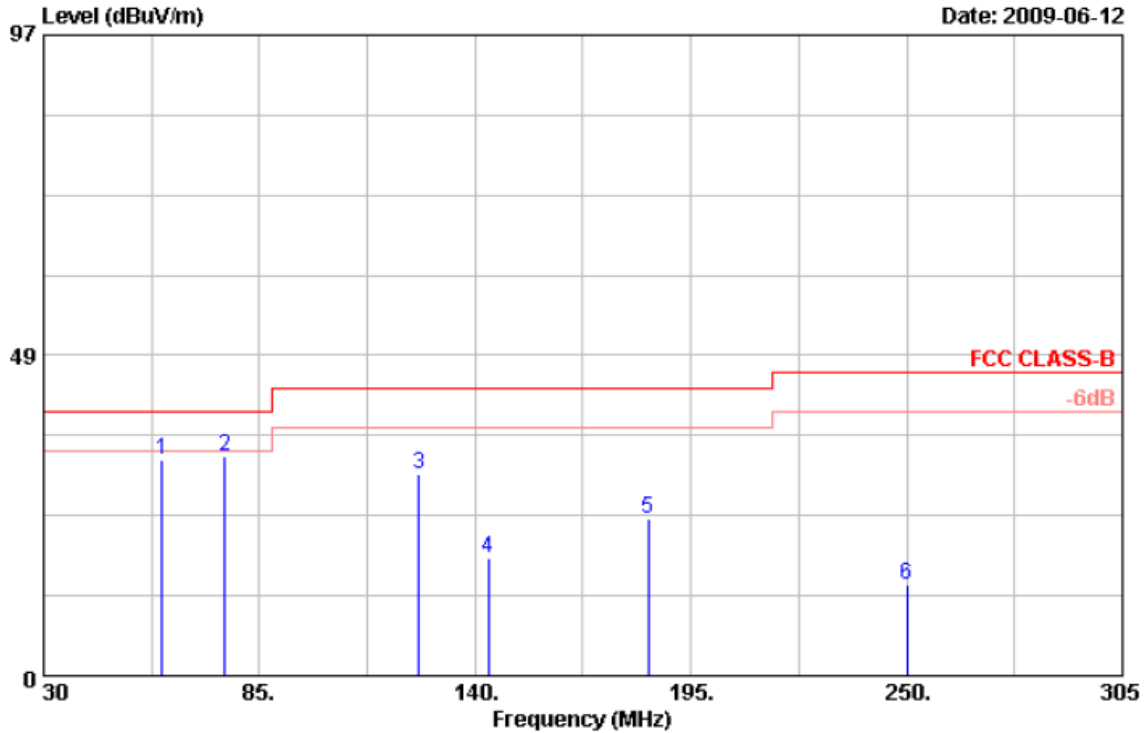

Item	Freq	Read Value	Factor	Result	Limit	Margin	Remark	Ant Pos	Tab Pos
	MHz	dBuV/m	dB	dBuV/m	dBuV/m	dB		cm	Deg
1	60.25	45.44	-12.85	32.59	40.00	-7.41	Peak	100	360
2	76.20	48.41	-15.16	33.25	40.00	-6.75	Peak	100	360
3	125.70	39.87	-9.31	30.56	43.50	-12.94	Peak	100	360
4	143.30	29.02	-11.17	17.85	43.50	-25.65	Peak	100	360
5	184.00	34.51	-10.71	23.80	43.50	-19.70	Peak	100	360
6	250.00	26.34	-12.64	13.70	46.00	-32.30	Peak	100	360

Notes:

1. Result = Read Value + Factor
2. Factor = Antenna Factor + Cable Loss - Amplifier
3. The resolution bandwidth of test receiver/spectrum analyzer is 120KHz and video bandwidth is 300kHz for Peak detection and Quasi-peak detection at frequency below 1GHz.
4. All emission below 1GHz at 802.11g mode are all the same, so the 802.11g mode chosen as representative in final test.
5. According to technical experiences, all spurious emission of 802.11g mode at channel 1, 6, 11 are almost the same below 1GHz, so that the channel 1 was chosen as representative in final test.
6. The data is worse case.



Power	: AC 120V	Pol/Phase	: VERTICAL
Test Mode	: Transmit / Receive	Temperature	: 26 °C
Operation Channel	: 1	Humidity	: 68 %
Modulation Type	: 802.11g	Atmospheric Pressure	: 1021 hPa
Memo	: Adapter: RHN-120100-1-3	Rate	: 54 Mbps

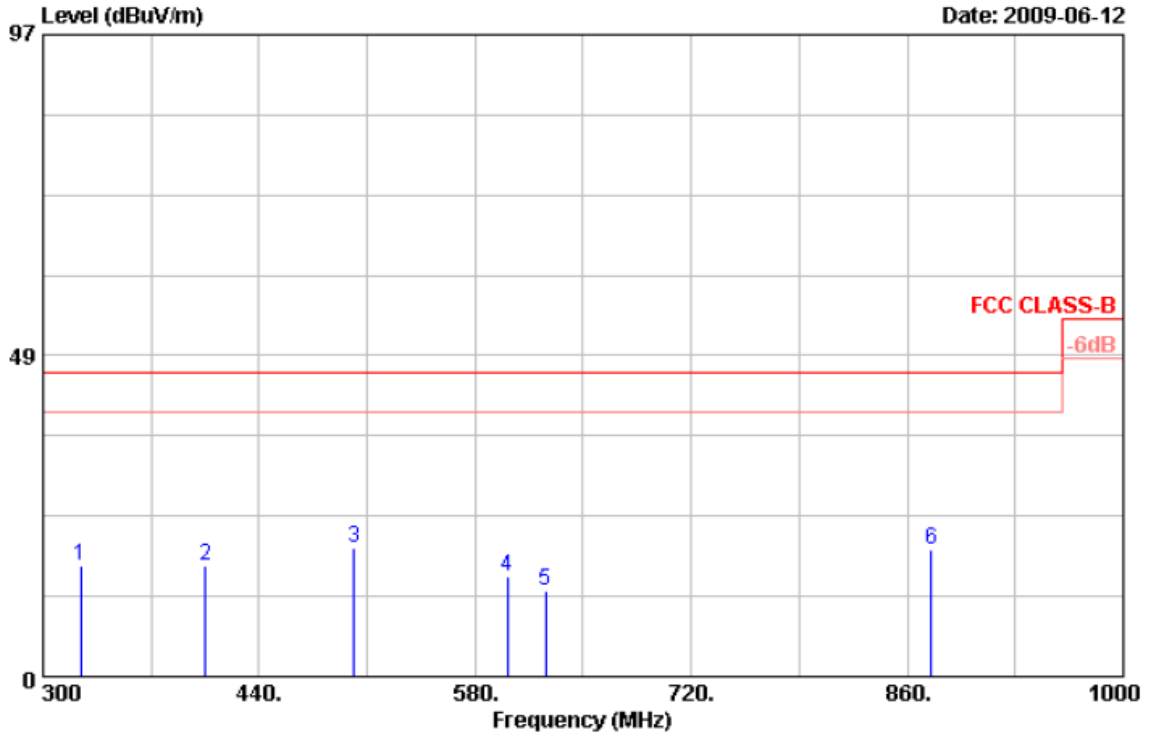

Item	Freq	Read Value	Factor	Result	Limit	Margin	Remark	Ant Pos	Tab Pos
	MHz	dBuV/m	dB	dBuV/m	dBuV/m	dB		cm	Deg
1	324.50	26.56	-9.78	16.78	46.00	-29.22	Peak	150	359
2	405.00	23.66	-6.82	16.84	46.00	-29.16	Peak	150	359
3	501.60	27.86	-8.44	19.42	46.00	-26.58	Peak	150	359
4	601.00	20.17	-4.99	15.18	46.00	-30.82	Peak	150	359
5	625.50	19.37	-6.52	12.85	46.00	-33.15	Peak	150	359
6	875.40	18.30	0.75	19.05	46.00	-26.95	Peak	150	359

Notes:

1. Result = Read Value + Factor
2. Factor = Antenna Factor + Cable Loss - Amplifier
3. The resolution bandwidth of test receiver/spectrum analyzer is 120KHz and video bandwidth is 300kHz for Peak detection and Quasi-peak detection at frequency below 1GHz.
4. All emission below 1GHz at 802.11b/g mode are all the same, so the 802.11g mode chosen as representative in final test.
5. According to technical experiences, all spurious emission of 802.11g mode at channel 1, 6, 11 are almost the same below 1GHz, so that the channel 1 was chosen as representative in final test.
6. The data is worse case.



Power	: AC 120V	Pol/Phase	: HORIZONTAL
Test Mode	: Transmit / Receive	Temperature	: 26 °C
Operation Channel	: 1	Humidity	: 68 %
Modulation Type	: 802.11g	Atmospheric Pressure	: 1021 hPa
Memo	: Adapter: RHN-120100-1-3	Rate	: 54 Mbps

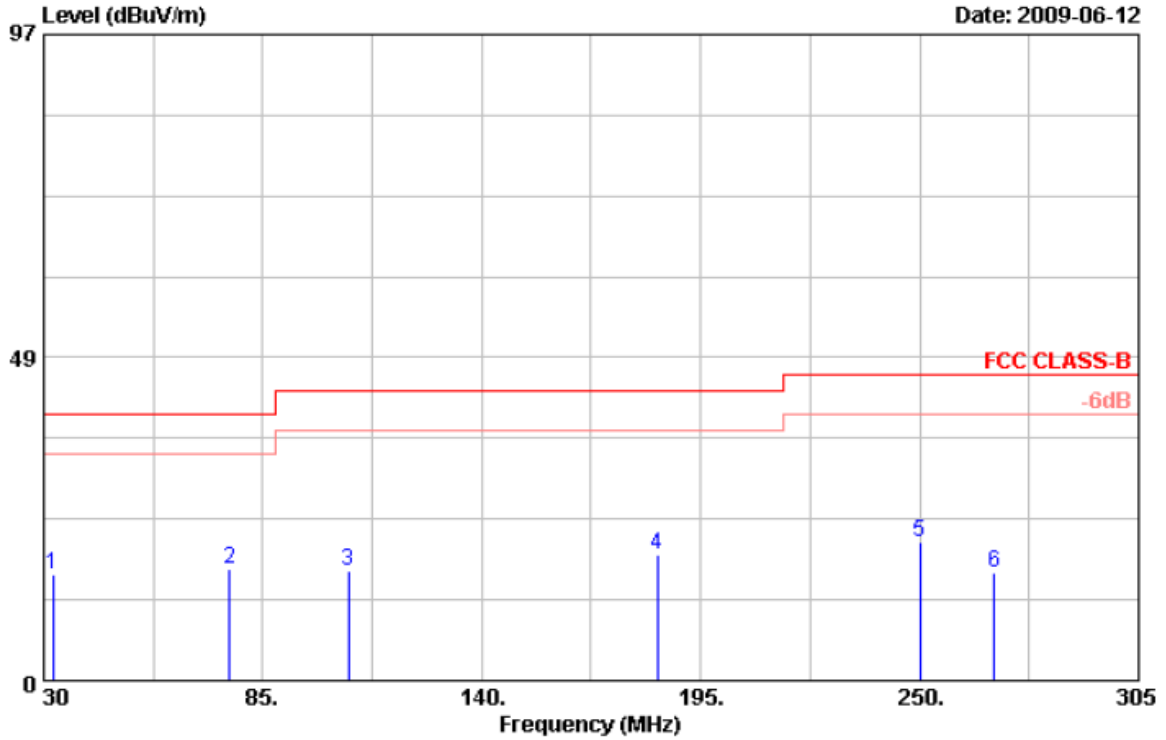

Item	Freq	Read Value	Factor	Result	Limit	Margin	Remark	Ant Pos	Tab Pos
	MHz	dBuV/m	dB	dBuV/m	dBuV/m	dB		cm	Deg
1	32.20	27.31	-11.39	15.92	40.00	-24.08	Peak	100	360
2	76.75	38.69	-21.90	16.79	40.00	-23.21	Peak	100	360
3	106.45	34.79	-18.20	16.59	43.50	-26.91	Peak	100	360
4	184.00	36.23	-17.35	18.88	43.50	-24.62	Peak	100	360
5	250.00	36.02	-15.28	20.74	46.00	-25.26	Peak	100	360
6	268.70	29.46	-13.36	16.10	46.00	-29.90	Peak	100	360

Notes:

1. Result = Read Value + Factor
2. Factor = Antenna Factor + Cable Loss - Amplifier
3. The resolution bandwidth of test receiver/spectrum analyzer is 120KHz and video bandwidth is 300kHz for Peak detection and Quasi-peak detection at frequency below 1GHz.
4. All emission below 1GHz at 802.11b/g mode are all the same,so the 802.11g mode chosen as representative in final test.
5. According to technical experiences,all spurious emission of 802.11g mode at channel 1,6,11 are almost the same below 1GHz,so that the channel 1 was chosen as representative in final test.
6. The data is worse case.



Power	: AC 120V	Pol/Phase	: HORIZONTAL
Test Mode	: Transmit / Receive	Temperature	: 26 °C
Operation Channel	: 1	Humidity	: 68 %
Modulation Type	: 802.11g	Atmospheric Pressure	: 1021 hPa
Memo	: Adapter: RHN-120100-1-3	Rate	: 54 Mbps

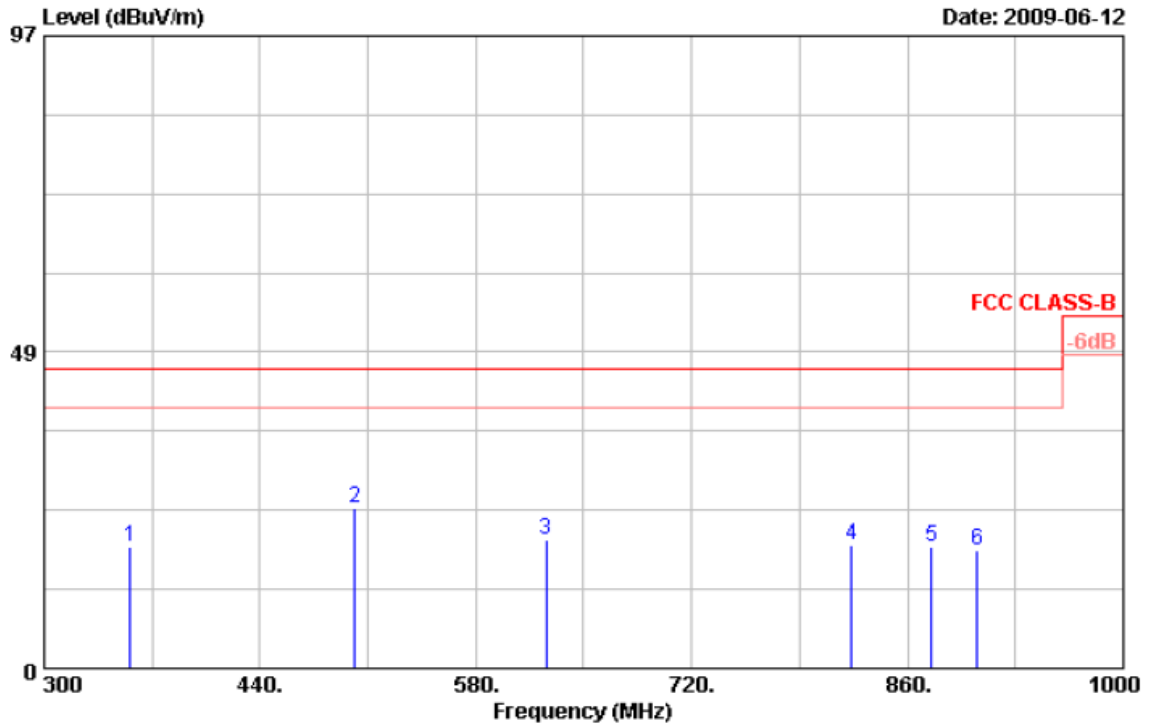

Item	Freq	Read Value	Factor	Result	Limit	Margin	Remark	Ant Pos	Tab Pos
	MHz	dBUV/m	dB	dBUV/m	dBUV/m	dB		cm	Deg
1	356.00	29.88	-11.11	18.77	46.00	-27.23	Peak	150	360
2	501.60	30.09	-5.42	24.67	46.00	-21.33	Peak	150	360
3	625.50	21.09	-1.45	19.64	46.00	-26.36	Peak	150	360
4	823.60	17.78	1.22	19.00	46.00	-27.00	Peak	150	360
5	875.40	18.64	0.06	18.70	46.00	-27.30	Peak	150	360
6	905.50	15.85	2.28	18.13	46.00	-27.87	Peak	150	360

Notes:

1. Result = Read Value + Factor
2. Factor = Antenna Factor + Cable Loss - Amplifier
3. The resolution bandwidth of test receiver/spectrum analyzer is 120KHz and video bandwidth is 300kHz for Peak detection and Quasi-peak detection at frequency below 1GHz.
4. All emission below 1GHz at 802.11b/g mode are all the same,so the 802.11g mode chosen as representative in final test.
5. According to technical experiences,all spurious emission of 802.11g mode at channel 1,6,11 are almost the same below 1GHz,so that the channel 1 was chosen as representative in final test.
6. The data is worse case.



Power	: AC 120V	Pol/Phase	: VERTICAL
Test Mode	: Transmit / Receive	Temperature	: 26 °C
Operation Channel	: 1	Humidity	: 68 %
Modulation Type	: 802.11b	Atmospheric Pressure	: 1018 hPa
Memo	: Adapter: RHN-120100-1-3	Rate	: 11 Mbps

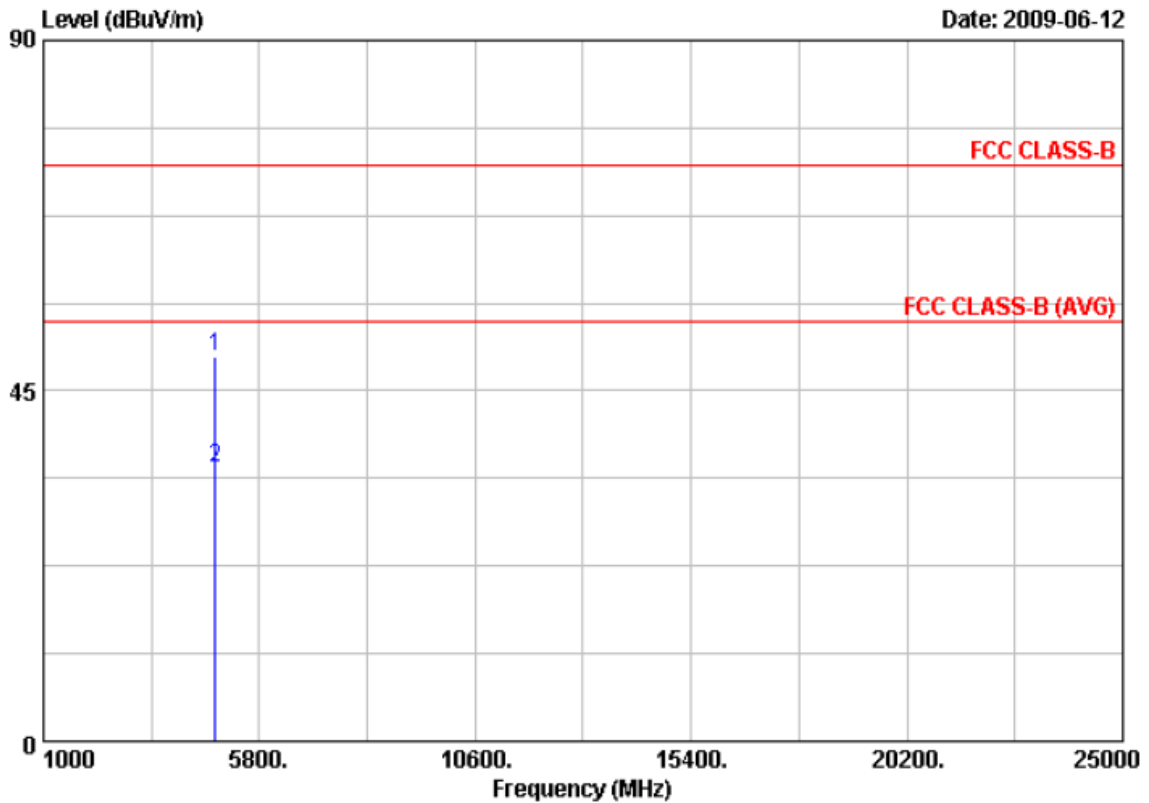

Item	Freq	Read Value	Factor	Result	Limit	Margin	Remark	Ant Pos	Tab Pos
	MHz	dBUV/m	dB	dBUV/m	dBUV/m	dB		cm	Deg
1	4820.02	46.95	2.55	49.50	74.00	-24.50	Peak	100	0
2	4824.01	32.44	2.55	34.99	54.00	-19.01	Average	100	0

Notes:

1. Result = Read Value + Factor
2. Factor = Antenna Factor + Cable Loss - Amplifier
3. The resolution bandwidth of test receiver/spectrum analyzer is 120KHz and video bandwidth is 300kHz for Peak detection and Quasi-peak detection at frequency below 1GHz.
4. The resolution bandwidth of test receiver/spectrum analyzer is 1MHz and video bandwidth is 3MHz for Peak detection at frequency above 1GHz.
5. The resolution bandwidth of test receiver/spectrum analyzer is 1MHz and video bandwidth is 10Hz for Average detection at frequency above 1GHz.
6. The other emissions is too low to be measured.



Power	: AC 120V	Pol/Phase	: HORIZONTAL
Test Mode	: Transmit / Receive	Temperature	: 26 °C
Operation Channel	: 1	Humidity	: 68 %
Modulation Type	: 802.11b	Atmospheric Pressure	: 1018 hPa
Memo	: Adapter: RHN-120100-1-3	Rate	: 11 Mbps

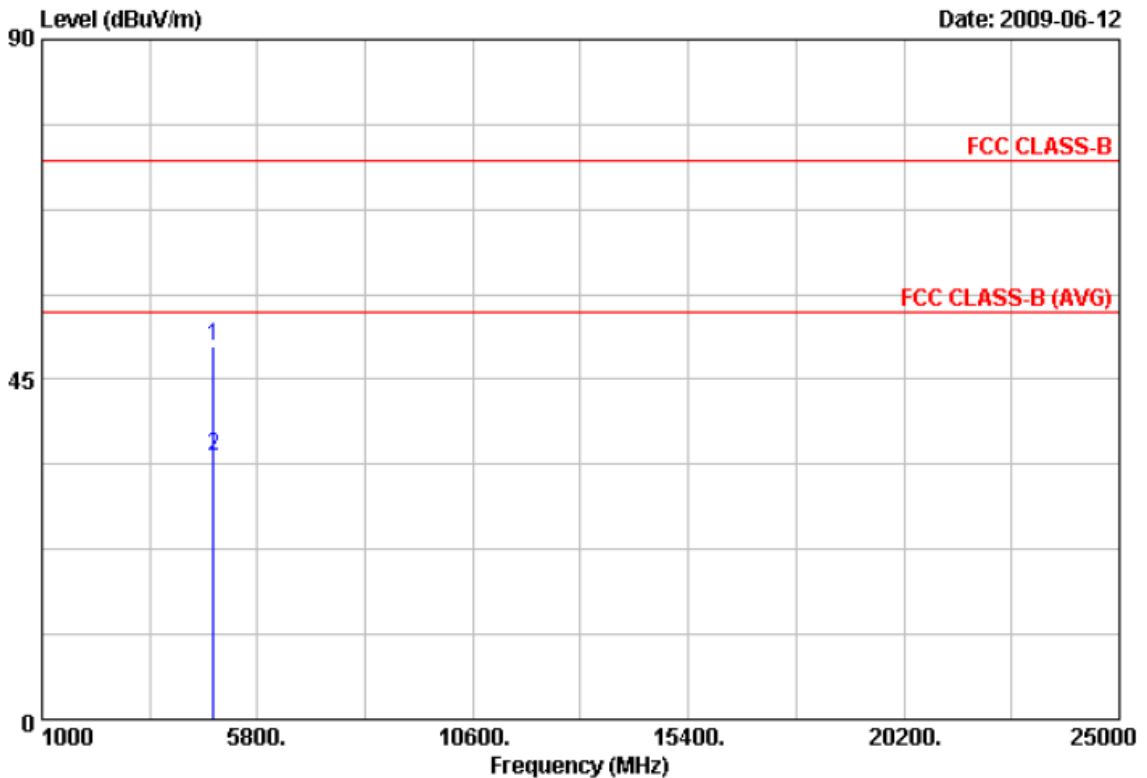

Item	Freq MHz	Read		Factor dB	Result dBuV/m	Limit dBuV/m	Margin dB	Remark	Ant Pos cm	Tab Pos Deg
		Value dBuV/m								
1	4820.96	46.84		2.55	49.39	74.00	-24.61	Peak	100	0
2	4826.67	32.36		2.57	34.93	54.00	-19.07	Average	100	0

Notes:

1. Result = Read Value + Factor
2. Factor = Antenna Factor + Cable Loss - Amplifier
3. The resolution bandwidth of test receiver/spectrum analyzer is 120KHz and video bandwidth is 300kHz for Peak detection and Quasi-peak detection at frequency below 1GHz.
4. The resolution bandwidth of test receiver/spectrum analyzer is 1MHz and video bandwidth is 3MHz for Peak detection at frequency above 1GHz.
5. The resolution bandwidth of test receiver/spectrum analyzer is 1MHz and video bandwidth is 10Hz for Average detection at frequency above 1GHz.
6. The other emissions is too low to be measured.



Power	: AC 120V	Pol/Phase	: VERTICAL
Test Mode	: Transmit / Receive	Temperature	: 26 °C
Operation Channel	: 6	Humidity	: 68 %
Modulation Type	: 802.11b	Atmospheric Pressure	: 1018 hPa
Memo	: Adapter: RHN-120100-1-3	Rate	: 11 Mbps

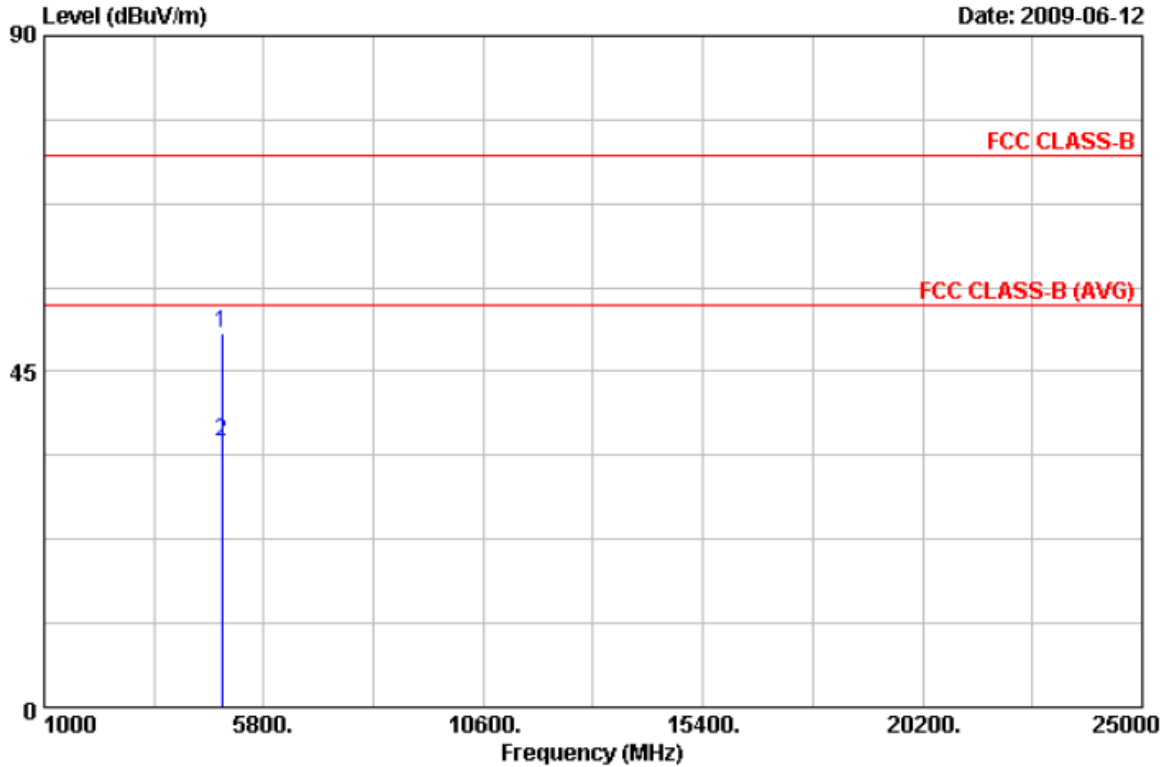

Item	Freq	Read Value	Factor	Result	Limit	Margin	Remark	Ant Pos	Tab Pos
	MHz	dBuV/m	dB	dBuV/m	dBuV/m	dB		cm	Deg
1	4875.37	47.45	2.71	50.16	74.00	-23.84	Peak	100	0
2	4876.37	32.77	2.71	35.48	54.00	-18.52	Average	100	0

Notes:

1. Result = Read Value + Factor
2. Factor = Antenna Factor + Cable Loss - Amplifier
3. The resolution bandwidth of test receiver/spectrum analyzer is 120KHz and video bandwidth is 300kHz for Peak detection and Quasi-peak detection at frequency below 1GHz.
4. The resolution bandwidth of test receiver/spectrum analyzer is 1MHz and video bandwidth is 3MHz for Peak detection at frequency above 1GHz.
5. The resolution bandwidth of test receiver/spectrum analyzer is 1MHz and video bandwidth is 10Hz for Average detection at frequency above 1GHz.
6. The other emissions is too low to be measured.



Power	: AC 120V	Pol/Phase	: HORIZONTAL
Test Mode	: Transmit / Receive	Temperature	: 26 °C
Operation Channel	: 6	Humidity	: 68 %
Modulation Type	: 802.11b	Atmospheric Pressure	: 1018 hPa
Memo	: Adapter: RHN-120100-1-3	Rate	: 11 Mbps

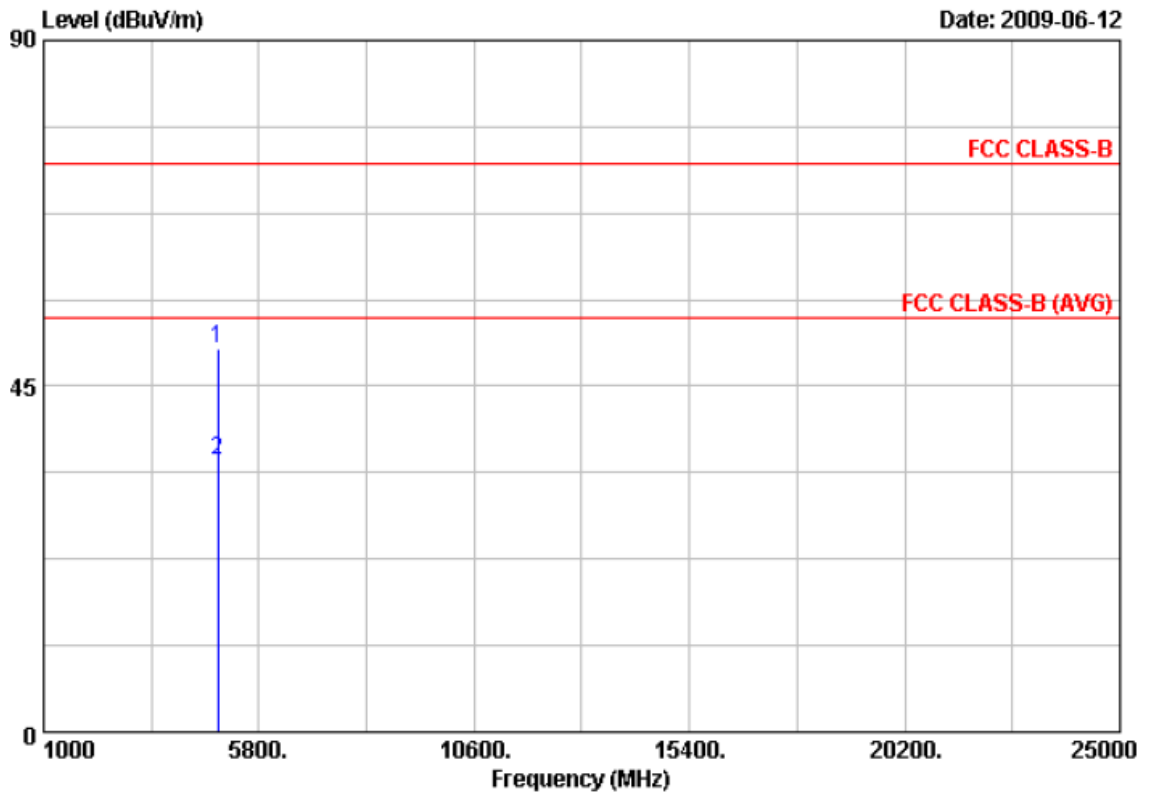

Item	Freq	Read Value	Factor	Result	Limit	Margin	Remark	Ant Pos	Tab Pos
	MHz	dBuV/m	dB	dBuV/m	dBuV/m	dB		cm	Deg
1	4875.13	47.12	2.71	49.83	74.00	-24.17	Peak	100	0
2	4876.41	32.75	2.71	35.46	54.00	-18.54	Average	100	0

Notes:

1. Result = Read Value + Factor
2. Factor = Antenna Factor + Cable Loss - Amplifier
3. The resolution bandwidth of test receiver/spectrum analyzer is 120KHz and video bandwidth is 300kHz for Peak detection and Quasi-peak detection at frequency below 1GHz.
4. The resolution bandwidth of test receiver/spectrum analyzer is 1MHz and video bandwidth is 3MHz for Peak detection at frequency above 1GHz.
5. The resolution bandwidth of test receiver/spectrum analyzer is 1MHz and video bandwidth is 10Hz for Average detection at frequency above 1GHz.
6. The other emissions is too low to be measured.



Power	: AC 120V	Pol/Phase	: VERTICAL
Test Mode	: Transmit / Receive	Temperature	: 26 °C
Operation Channel	: 11	Humidity	: 68 %
Modulation Type	: 802.11b	Atmospheric Pressure	: 1018 hPa
Memo	: Adapter: RHN-120100-1-3	Rate	: 11 Mbps

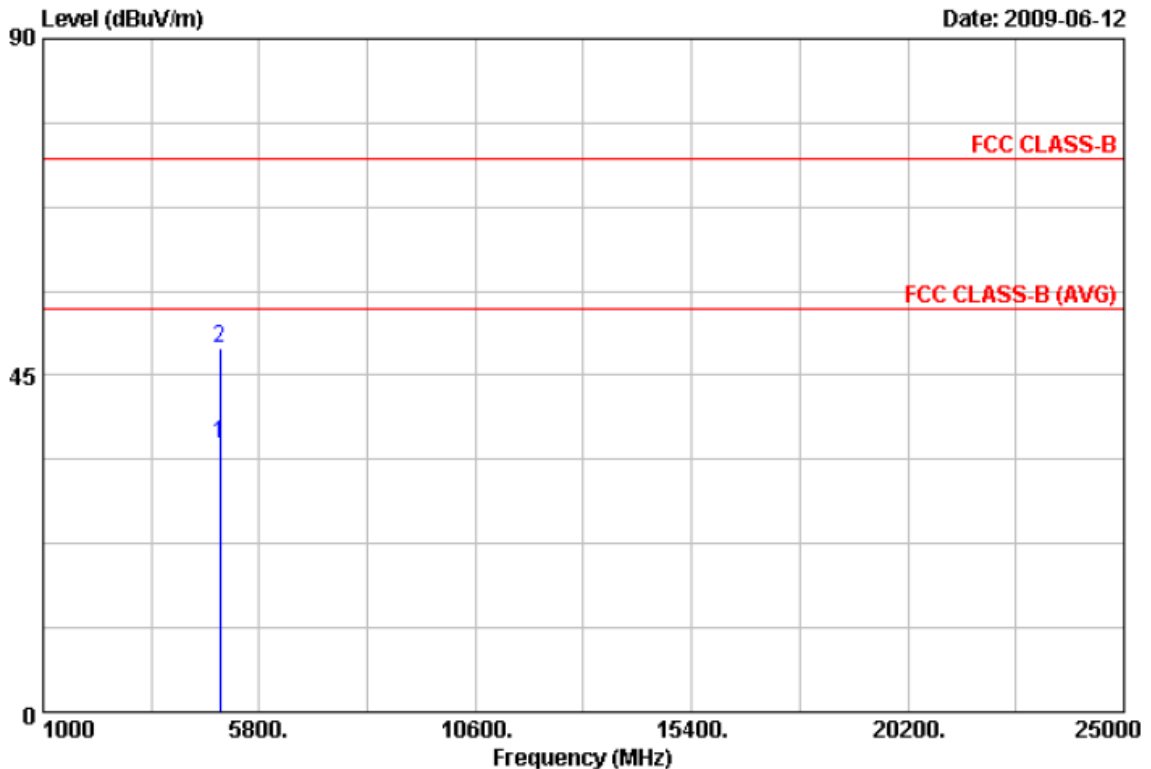

Item	Freq	Read Value	Factor	Result	Limit	Margin	Remark	Ant Pos	Tab Pos
	MHz	dBuV/m	dB	dBuV/m	dBuV/m	dB		cm	Deg
1	4920.71	33.05	2.82	35.87	54.00	-18.13	Average	100	0
2	4929.00	45.84	2.84	48.68	74.00	-25.32	Peak	100	0

Notes:

1. Result = Read Value + Factor
2. Factor = Antenna Factor + Cable Loss - Amplifier
3. The resolution bandwidth of test receiver/spectrum analyzer is 120KHz and video bandwidth is 300kHz for Peak detection and Quasi-peak detection at frequency below 1GHz.
4. The resolution bandwidth of test receiver/spectrum analyzer is 1MHz and video bandwidth is 3MHz for Peak detection at frequency above 1GHz.
5. The resolution bandwidth of test receiver/spectrum analyzer is 1MHz and video bandwidth is 10Hz for Average detection at frequency above 1GHz.
6. The other emissions is too low to be measured.



Power	: AC 120V	Pol/Phase	: HORIZONTAL
Test Mode	: Transmit / Receive	Temperature	: 26 °C
Operation Channel	: 11	Humidity	: 68 %
Modulation Type	: 802.11b	Atmospheric Pressure	: 1018 hPa
Memo	: Adapter: RHN-120100-1-3	Rate	: 11 Mbps

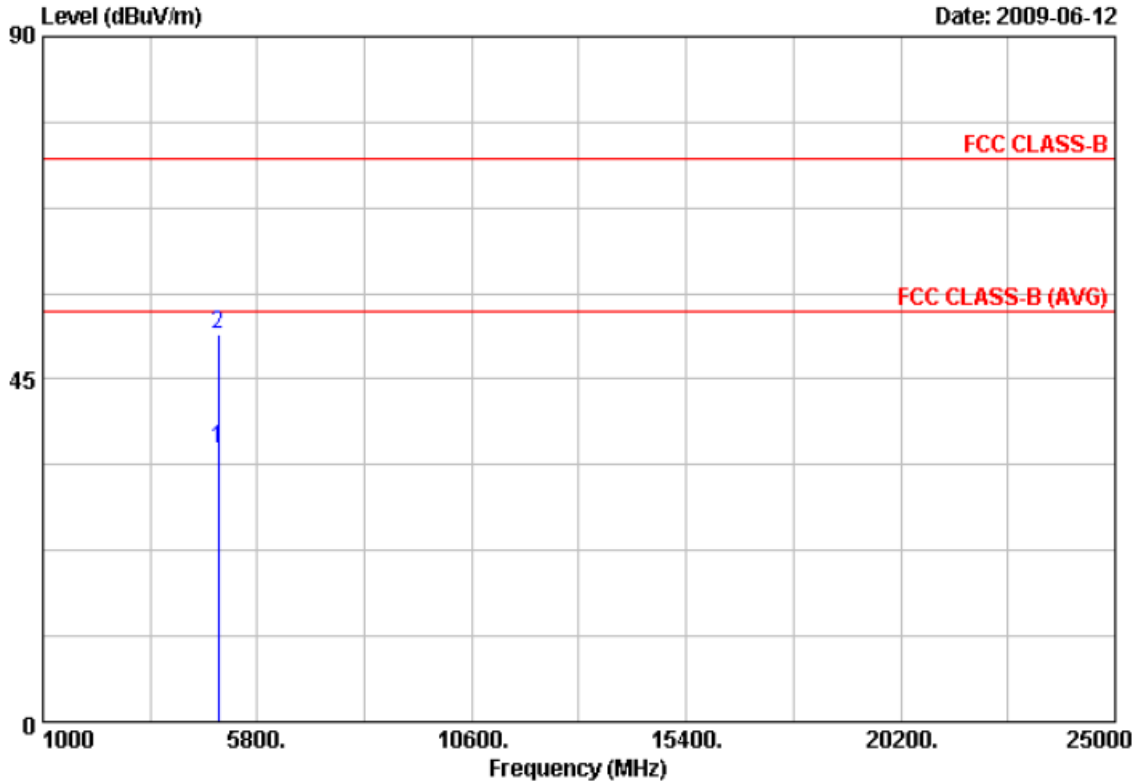

Item	Freq	Read Value	Factor	Result	Limit	Margin	Remark	Ant Pos	Tab Pos
	MHz	dBUV/m	dB	dBUV/m	dBUV/m	dB		cm	Deg
1	4920.64	33.03	2.82	35.85	54.00	-18.15	Average	100	0
2	4928.23	48.09	2.84	50.93	74.00	-23.07	Peak	100	0

Notes:

1. Result = Read Value + Factor
2. Factor = Antenna Factor + Cable Loss - Amplifier
3. The resolution bandwidth of test receiver/spectrum analyzer is 120KHz and video bandwidth is 300kHz for Peak detection and Quasi-peak detection at frequency below 1GHz.
4. The resolution bandwidth of test receiver/spectrum analyzer is 1MHz and video bandwidth is 3MHz for Peak detection at frequency above 1GHz.
5. The resolution bandwidth of test receiver/spectrum analyzer is 1MHz and video bandwidth is 10Hz for Average detection at frequency above 1GHz.
6. The other emissions is too low to be measured.



Power	: AC 120V	Pol/Phase	: VERTICAL
Test Mode	: Transmit / Receive	Temperature	: 26 °C
Operation Channel	: 1	Humidity	: 68 %
Modulation Type	: 802.11g	Atmospheric Pressure	: 1018 hPa
Memo	: Adapter: RHN-120100-1-3	Rate	: 54 Mbps

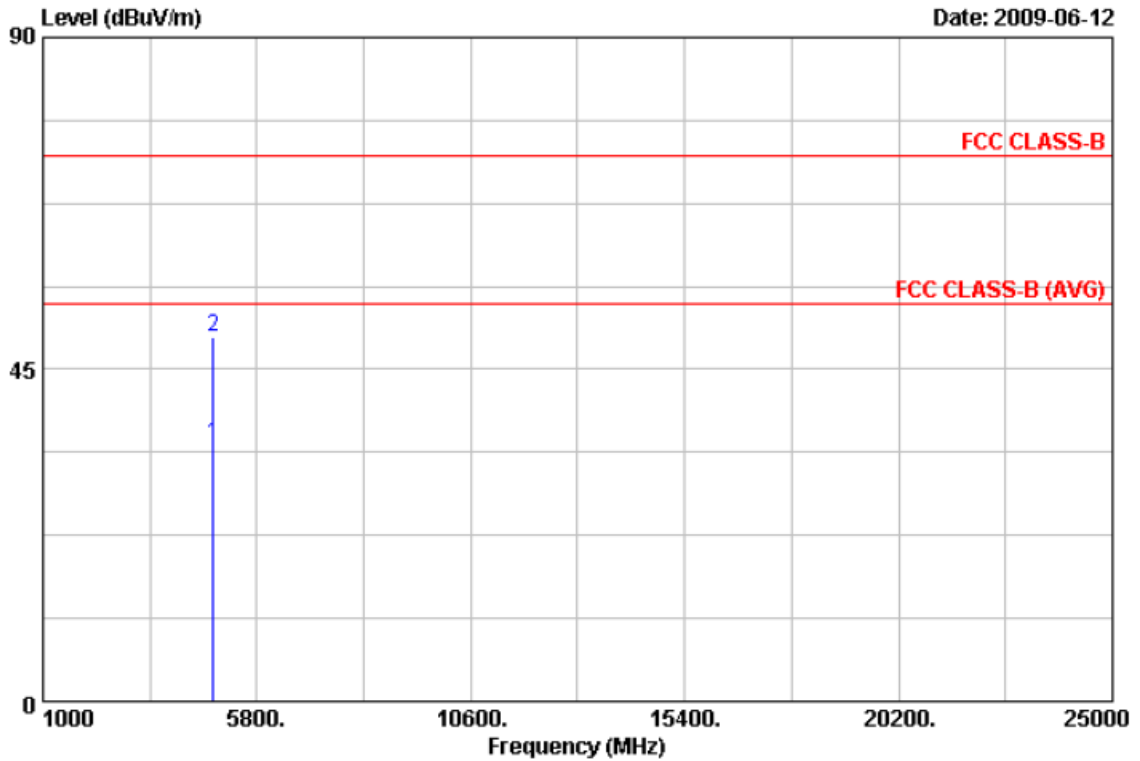

Item	Freq	Read Value	Factor	Result	Limit	Margin	Remark	Ant Pos	Tab Pos
	MHz	dBuV/m	dB	dBuV/m	dBuV/m	dB		cm	Deg
1	4826.65	32.30	2.57	34.87	54.00	-19.13	Average	100	0
2	4828.69	46.92	2.57	49.49	74.00	-24.51	Peak	100	0

Notes:

1. Result = Read Value + Factor
2. Factor = Antenna Factor + Cable Loss - Amplifier
3. The resolution bandwidth of test receiver/spectrum analyzer is 120KHz and video bandwidth is 300kHz for Peak detection and Quasi-peak detection at frequency below 1GHz.
4. The resolution bandwidth of test receiver/spectrum analyzer is 1MHz and video bandwidth is 3MHz for Peak detection at frequency above 1GHz.
5. The resolution bandwidth of test receiver/spectrum analyzer is 1MHz and video bandwidth is 10Hz for Average detection at frequency above 1GHz.
6. The other emissions is too low to be measured.



Power	: AC 120V	Pol/Phase	: HORIZONTAL
Test Mode	: Transmit / Receive	Temperature	: 26 °C
Operation Channel	: 1	Humidity	: 68 %
Modulation Type	: 802.11g	Atmospheric Pressure	: 1018 hPa
Memo	: Adapter: RHN-120100-1-3	Rate	: 54 Mbps

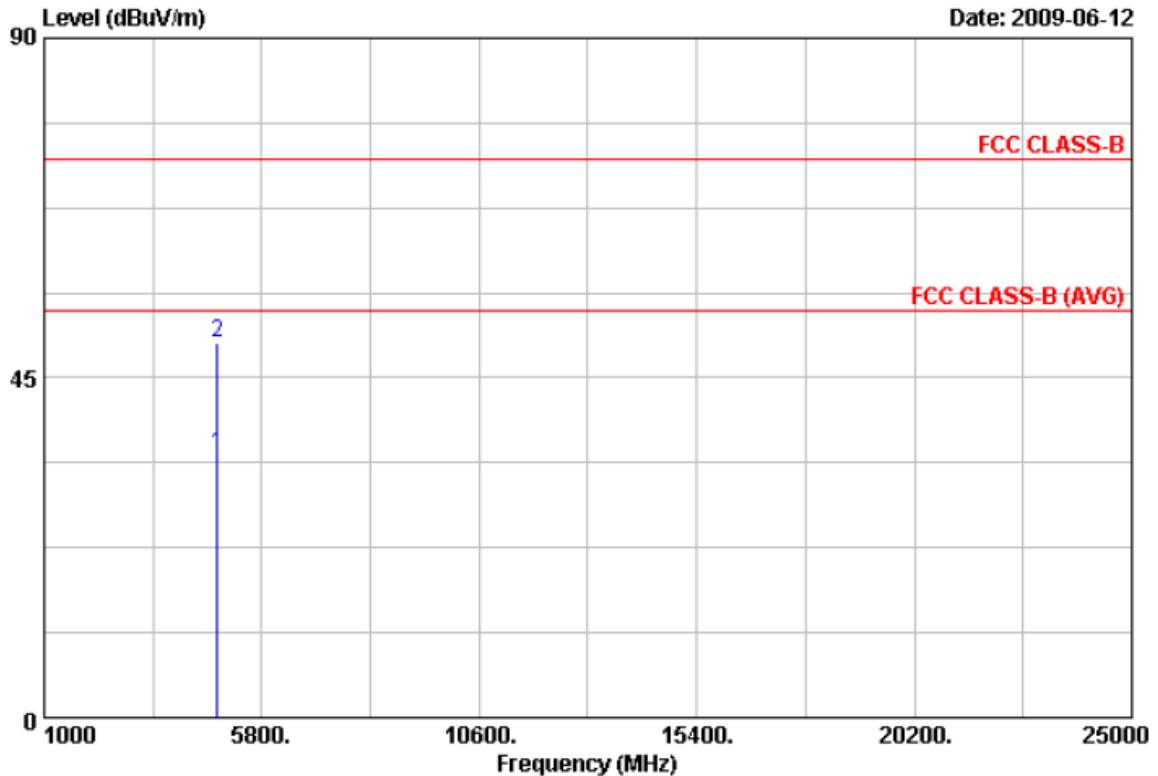

Item	Freq	Read Value	Factor	Result	Limit	Margin	Remark	Ant Pos	Tab Pos
	MHz	dBuV/m	dB	dBuV/m	dBuV/m	dB		cm	Deg
1	4826.68	32.37	2.57	34.94	54.00	-19.06	Average	100	0
2	4827.23	46.97	2.57	49.54	74.00	-24.46	Peak	100	0

Notes:

1. Result = Read Value + Factor
2. Factor = Antenna Factor + Cable Loss - Amplifier
3. The resolution bandwidth of test receiver/spectrum analyzer is 120KHz and video bandwidth is 300kHz for Peak detection and Quasi-peak detection at frequency below 1GHz.
4. The resolution bandwidth of test receiver/spectrum analyzer is 1MHz and video bandwidth is 3MHz for Peak detection at frequency above 1GHz.
5. The resolution bandwidth of test receiver/spectrum analyzer is 1MHz and video bandwidth is 10Hz for Average detection at frequency above 1GHz.
6. The other emissions is too low to be measured.



Power	: AC 120V	Pol/Phase	: VERTICAL
Test Mode	: Transmit / Receive	Temperature	: 26 °C
Operation Channel	: 6	Humidity	: 68 %
Modulation Type	: 802.11g	Atmospheric Pressure	: 1018 hPa
Memo	: Adapter: RHN-120100-1-3	Rate	: 54 Mbps

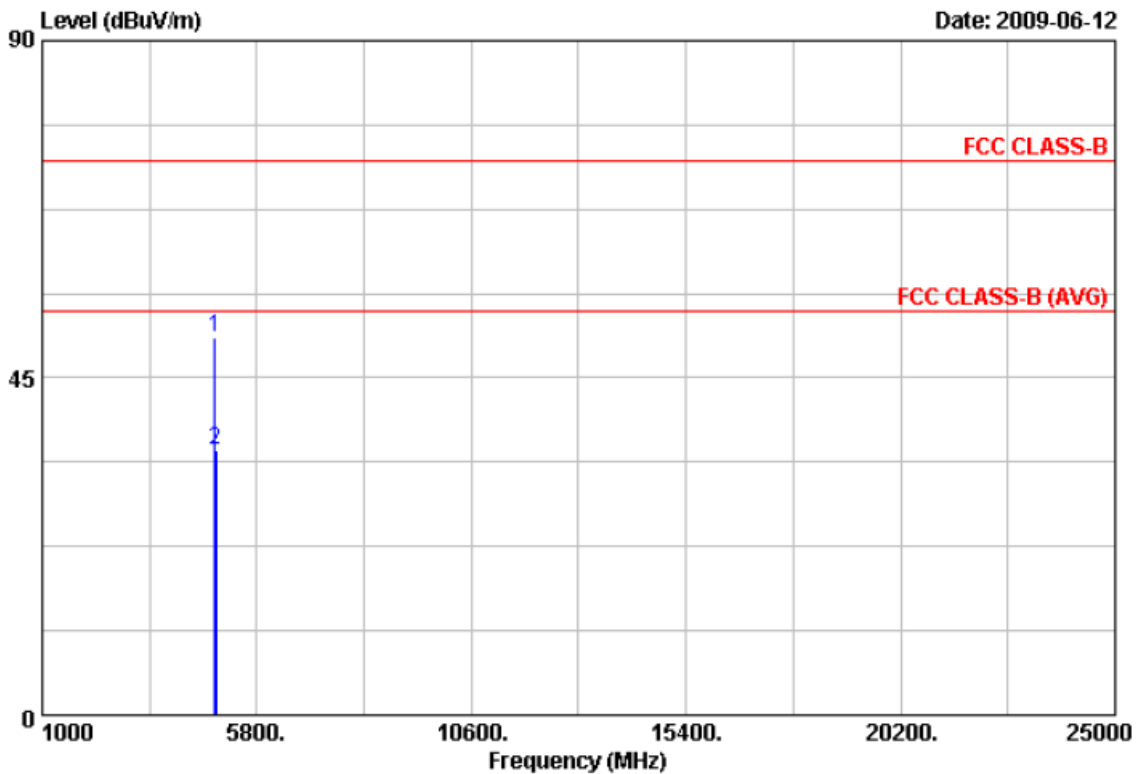

Item	Freq	Read Value	Factor	Result	Limit	Margin	Remark	Ant Pos	Tab Pos
	MHz	dBuV/m	dB	dBuV/m	dBuV/m	dB		cm	Deg
1	4872.31	47.63	2.68	50.31	74.00	-23.69	Peak	100	0
2	4878.86	32.64	2.71	35.35	54.00	-18.65	Average	100	0

Notes:

1. Result = Read Value + Factor
2. Factor = Antenna Factor + Cable Loss - Amplifier
3. The resolution bandwidth of test receiver/spectrum analyzer is 120KHz and video bandwidth is 300kHz for Peak detection and Quasi-peak detection at frequency below 1GHz.
4. The resolution bandwidth of test receiver/spectrum analyzer is 1MHz and video bandwidth is 3MHz for Peak detection at frequency above 1GHz.
5. The resolution bandwidth of test receiver/spectrum analyzer is 1MHz and video bandwidth is 10Hz for Average detection at frequency above 1GHz.
6. The other emissions is too low to be measured.



Power	: AC 120V	Pol/Phase	: HORIZONTAL
Test Mode	: Transmit / Receive	Temperature	: 26 °C
Operation Channel	: 6	Humidity	: 68 %
Modulation Type	: 802.11g	Atmospheric Pressure	: 1018 hPa
Memo	: Adapter: RHN-120100-1-3	Rate	: 54 Mbps

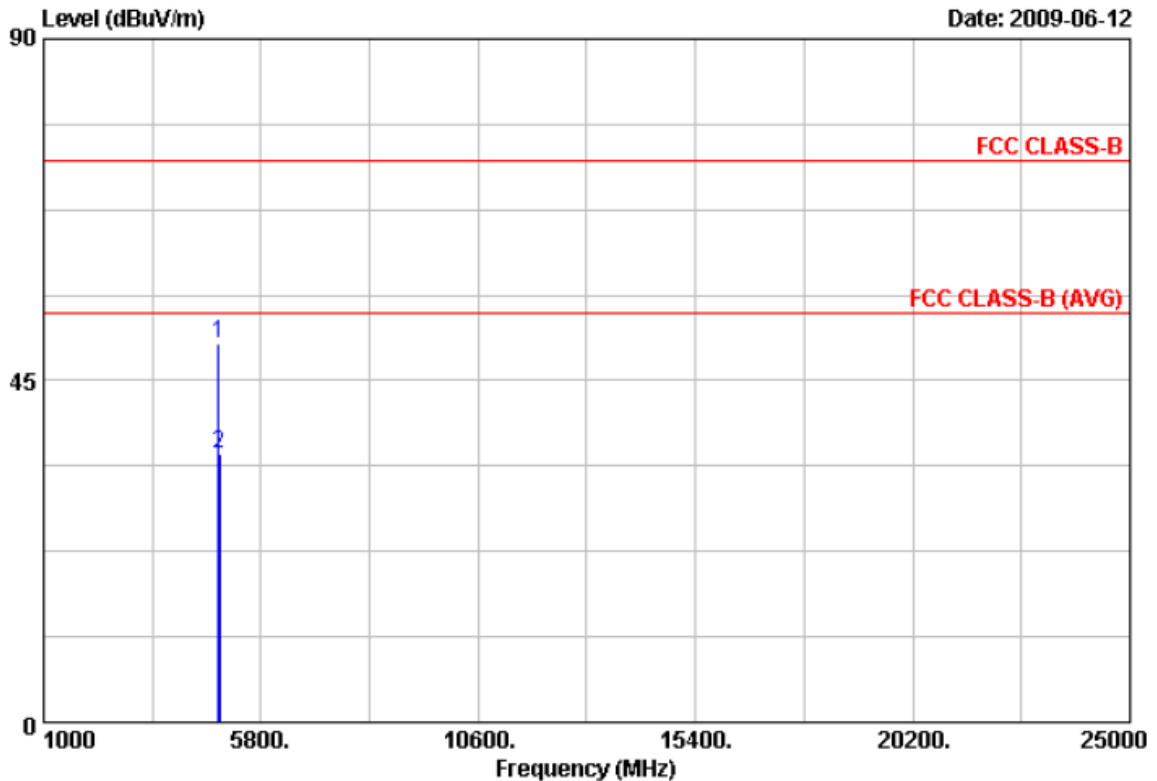

Item	Freq	Read Value	Factor	Result	Limit	Margin	Remark	Ant Pos	Tab Pos
	MHz	dBuV/m	dB	dBuV/m	dBuV/m	dB		cm	Deg
1	4870.96	47.33	2.68	50.01	74.00	-23.99	Peak	100	0
2	4879.00	32.62	2.71	35.33	54.00	-18.67	Average	100	0

Notes:

1. Result = Read Value + Factor
2. Factor = Antenna Factor + Cable Loss - Amplifier
3. The resolution bandwidth of test receiver/spectrum analyzer is 120KHz and video bandwidth is 300kHz for Peak detection and Quasi-peak detection at frequency below 1GHz.
4. The resolution bandwidth of test receiver/spectrum analyzer is 1MHz and video bandwidth is 3MHz for Peak detection at frequency above 1GHz.
5. The resolution bandwidth of test receiver/spectrum analyzer is 1MHz and video bandwidth is 10Hz for Average detection at frequency above 1GHz.
6. The other emissions is too low to be measured.



Power	: AC 120V	Pol/Phase	: VERTICAL
Test Mode	: Transmit / Receive	Temperature	: 26 °C
Operation Channel	: 11	Humidity	: 68 %
Modulation Type	: 802.11g	Atmospheric Pressure	: 1018 hPa
Memo	: Adapter: RHN-120100-1-3	Rate	: 54 Mbps

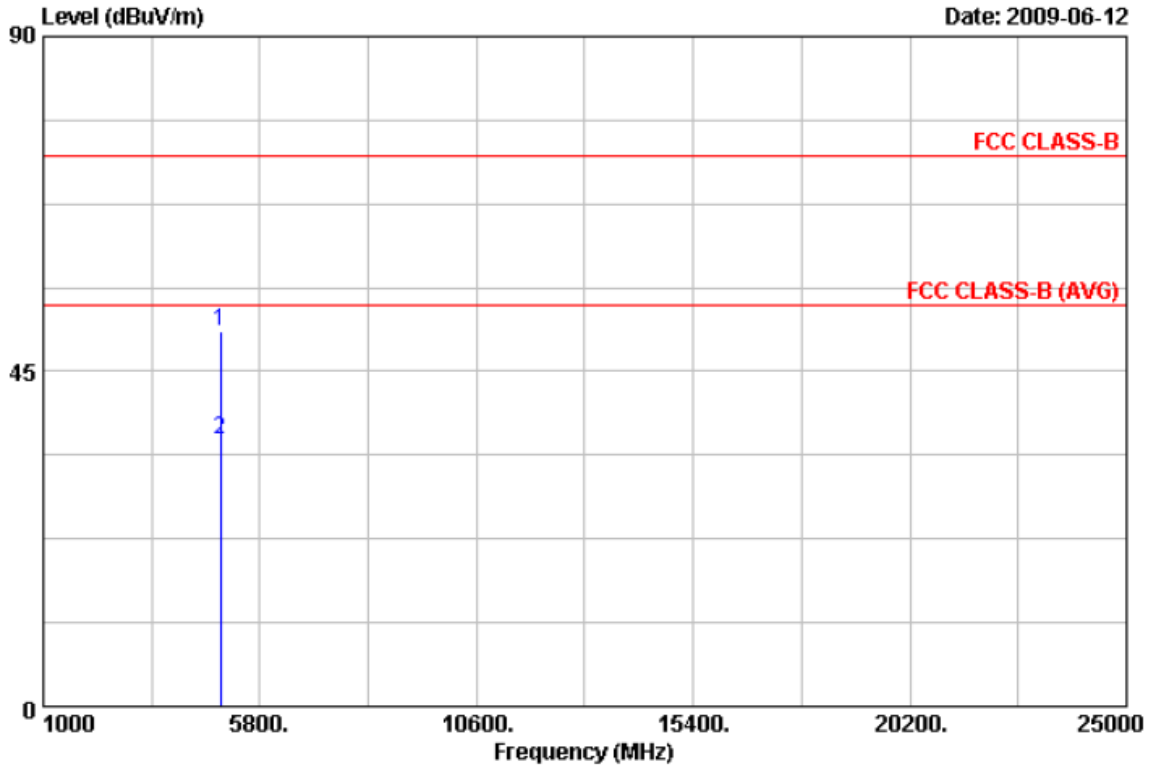

Item	Freq	Read Value	Factor	Result	Limit	Margin	Remark	Ant Pos	Tab Pos
	MHz	dBuV/m	dB	dBuV/m	dBuV/m	dB		cm	Deg
1	4927.19	47.48	2.84	50.32	74.00	-23.68	Peak	100	0
2	4928.42	32.98	2.84	35.82	54.00	-18.18	Average	100	0

Notes:

1. Result = Read Value + Factor
2. Factor = Antenna Factor + Cable Loss - Amplifier
3. The resolution bandwidth of test receiver/spectrum analyzer is 120KHz and video bandwidth is 300kHz for Peak detection and Quasi-peak detection at frequency below 1GHz.
4. The resolution bandwidth of test receiver/spectrum analyzer is 1MHz and video bandwidth is 3MHz for Peak detection at frequency above 1GHz.
5. The resolution bandwidth of test receiver/spectrum analyzer is 1MHz and video bandwidth is 10Hz for Average detection at frequency above 1GHz.
6. The other emissions is too low to be measured.



Power	: AC 120V	Pol/Phase	: HORIZONTAL
Test Mode	: Transmit / Receive	Temperature	: 26 °C
Operation Channel	: 11	Humidity	: 68 %
Modulation Type	: 802.11g	Atmospheric Pressure	: 1018 hPa
Memo	: Adapter: RHN-120100-1-3	Rate	: 54 Mbps

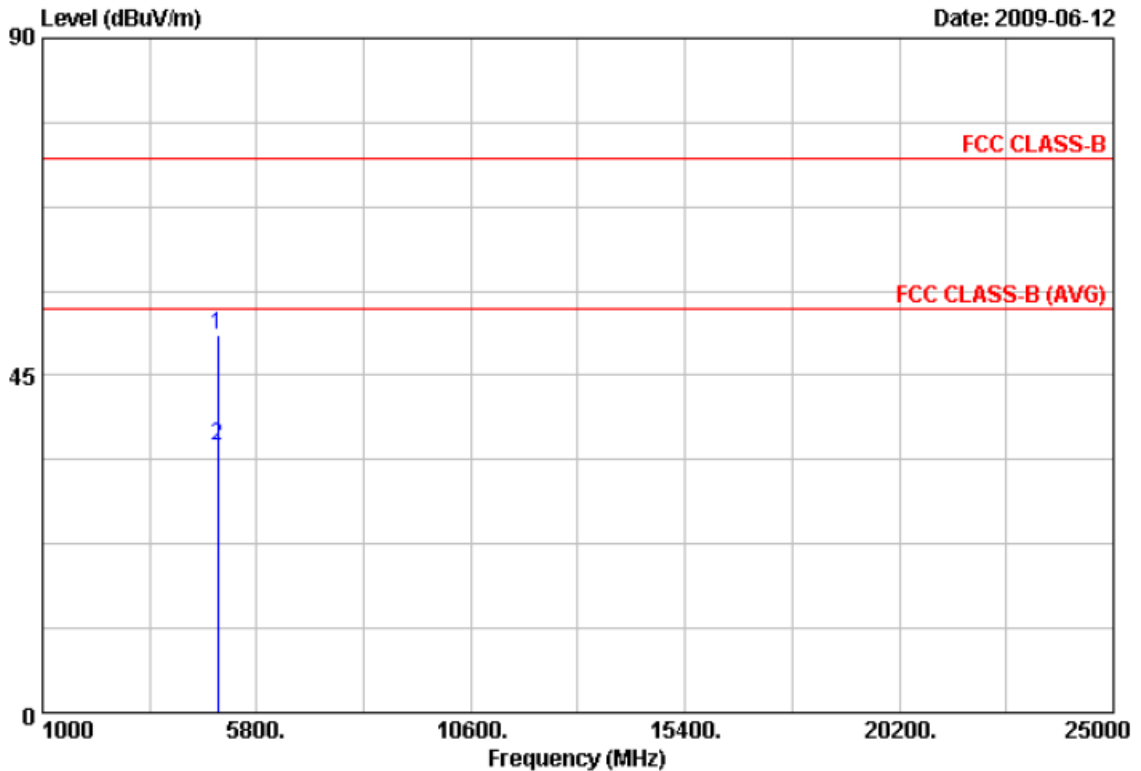

Item	Freq	Read Value	Factor	Result	Limit	Margin	Remark	Ant Pos	Tab Pos
	MHz	dBuV/m	dB	dBuV/m	dBuV/m	dB		cm	Deg
1	4923.88	47.49	2.82	50.31	74.00	-23.69	Peak	100	0
2	4928.14	32.84	2.84	35.68	54.00	-18.32	Average	100	0

Notes:

1. Result = Read Value + Factor
2. Factor = Antenna Factor + Cable Loss - Amplifier
3. The resolution bandwidth of test receiver/spectrum analyzer is 120KHz and video bandwidth is 300kHz for Peak detection and Quasi-peak detection at frequency below 1GHz.
4. The resolution bandwidth of test receiver/spectrum analyzer is 1MHz and video bandwidth is 3MHz for Peak detection at frequency above 1GHz.
5. The resolution bandwidth of test receiver/spectrum analyzer is 1MHz and video bandwidth is 10Hz for Average detection at frequency above 1GHz.
6. The other emissions is too low to be measured.

Test engineer: Ben



6. 6dB Bandwidth Measurement Data

6.1 Test Limit

The minimum of 6dB Bandwidth Measurement is 0.5 MHz.

6.2 Test Procedures

- The transmitter output was connected to the spectrum analyzer.
- Set RBW of spectrum analyzer to 100 KHz and VBW to 100 KHz.
- The 6 dB bandwidth is defined as the total spectrum the power of which is higher than peak power minus 6 dB.

6.3 Test Setup Layout

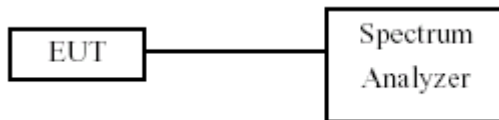

6.4 Measurement equipment

Instrument/Ancillary	Model No.	Manufacturer	Serial No.	Calibration Date	Valid Date
Spectrum Analyzer	FSP40	R&S	10047	2009/03/26	2010/03/25

6.5 Test Result and Data

Test Date: Jun. 12, 2009

Temperature: 26°C

Atmospheric pressure: 1014 hPa

Humidity: 66%

Modulation Standard	Channel	Frequency (MHz)	6dB Bandwidth (MHz)
802.11b (11Mbps)	01	2412	12.1
	06	2437	12.3
	11	2462	11.7
802.11g (54Mbps)	01	2412	16.5
	06	2437	16.5
	11	2462	16.5



Modulation Standard: 802.11b (11Mbps)
Channel: 01

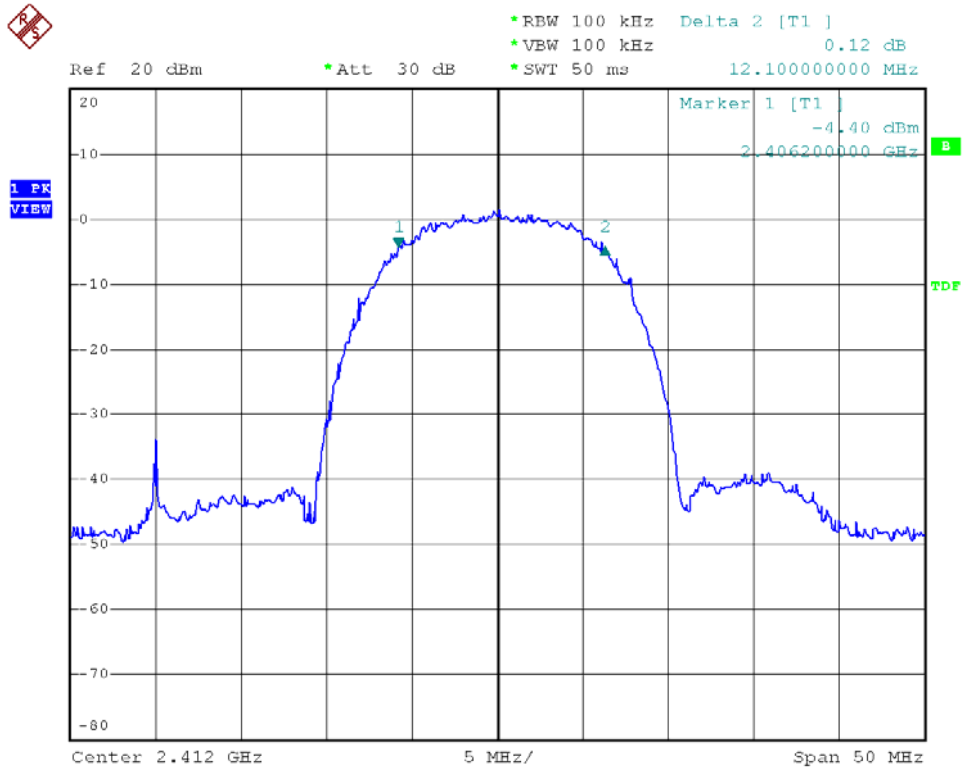

Modulation Standard: 802.11b (11Mbps)
Channel: 06

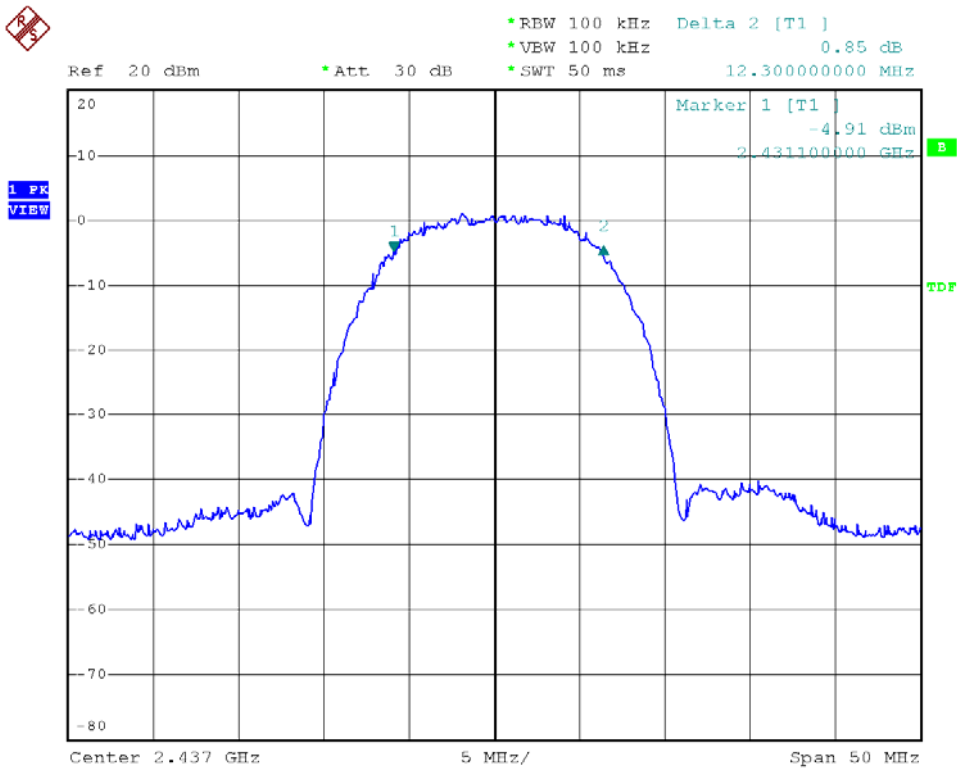



Modulation Standard: 802.11b (11Mbps)
Channel: 11

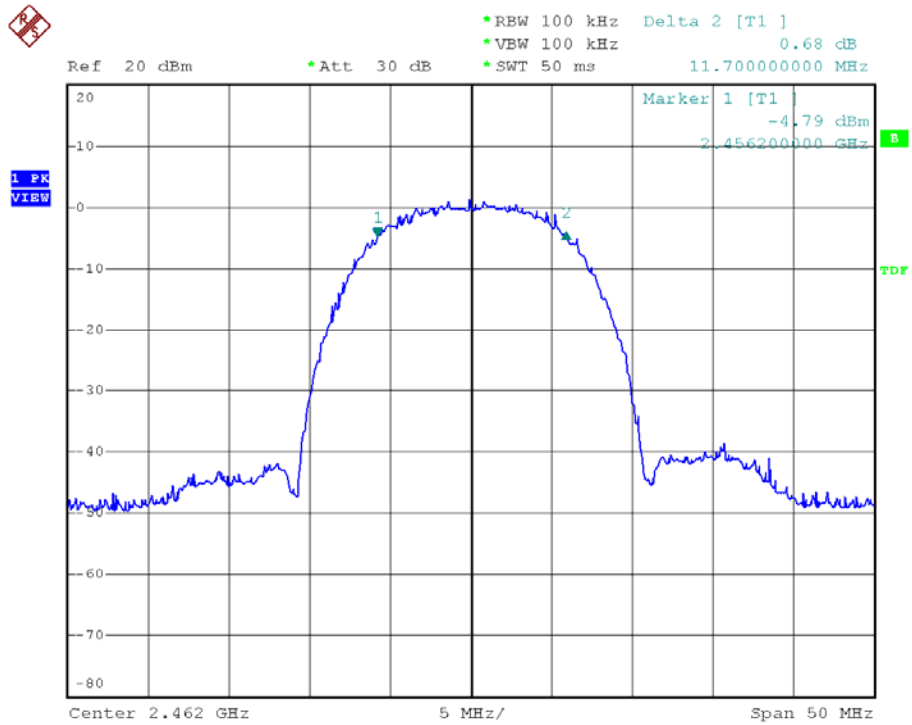

Modulation Standard: 802.11g (54Mbps)
Channel: 01

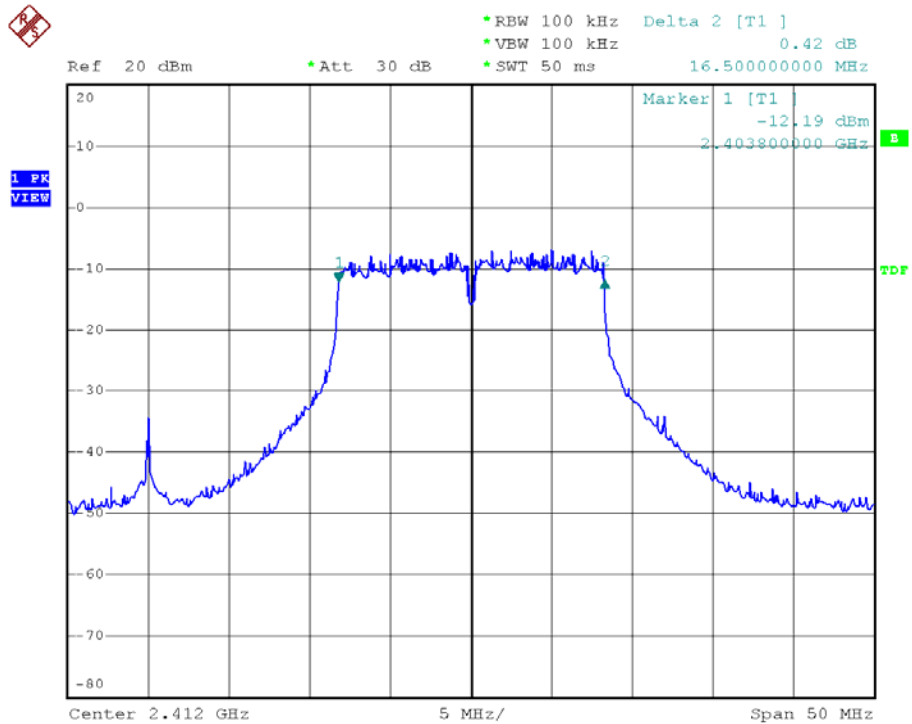



Modulation Standard: 802.11g (54Mbps)
Channel: 06

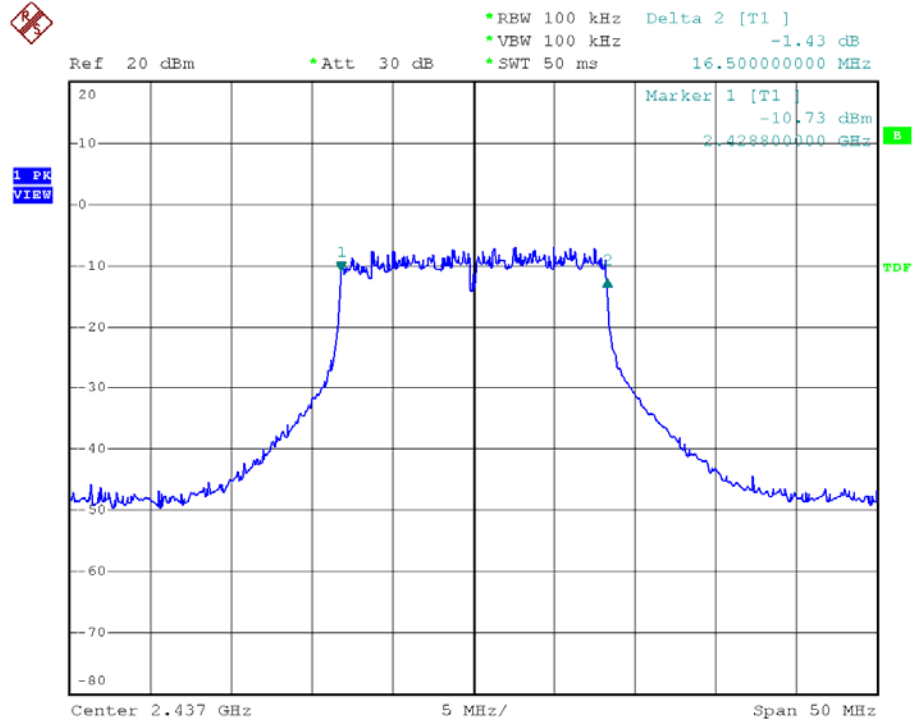

Modulation Standard: 802.11g (54Mbps)
Channel: 11

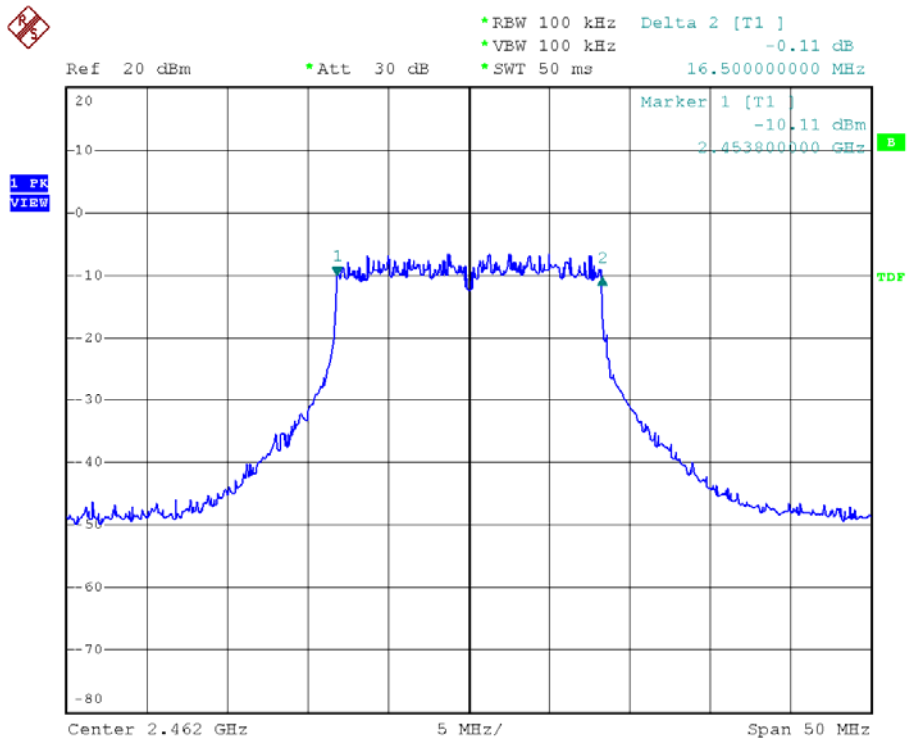



7. Maximum Peak Output Power

7.1 Test Limit

The Maximum Peak Output Power Measurement is 30dBm.

7.2 Test Procedures

The antenna port (RF output) of the EUT was connected to the input (RF input) of a power meter. Power was read directly from the meter and cable loss connection was added to the reading to obtain power at the EUT antenna terminal. The EUT Output Power was set to maximum to produce the worse case test result.

7.3 Test Setup Layout

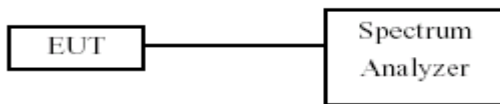

7.4 Measurement equipment

Instrument/Ancillary	Model No.	Manufacturer	Serial No.	Calibration Date	Valid Date
Spectrum Analyzer	FSP40	R&S	10047	2009/03/26	2010/03/25

7.5 Test Result and Data

Test Date: Jun. 12, 2009

Temperature: 26°C

Atmospheric pressure: 1014 hPa

Humidity: 66%

Modulation Standard	Channel	Frequency (MHz)	Peak Power Output (dBm)	Peak Power Output (mW)
802.11b (11Mbps)	01	2412	17.29	53.6
	06	2437	17.47	55.8
	11	2462	17.43	55.3
802.11g (54Mbps)	01	2412	13.40	21.9
	06	2437	13.28	21.3
	11	2462	13.71	23.5



Modulation Standard: 802.11g (54Mbps)
Channel: 06

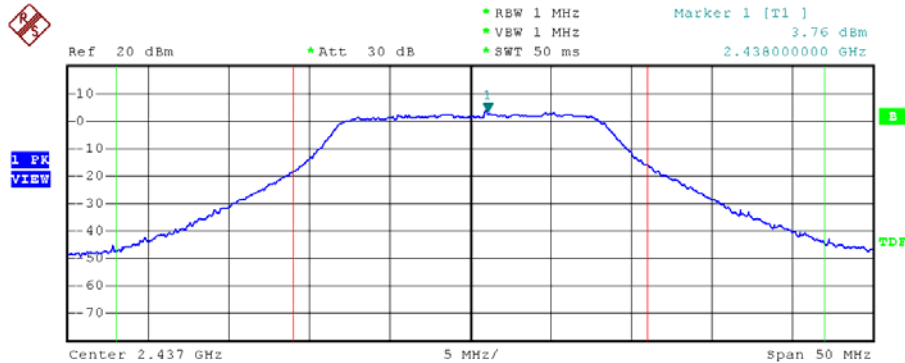

Tx Channel			
Bandwidth	22 MHz	Power	13.28 dBm
Adjacent Channel			
Bandwidth	11 MHz	Lower	-31.31 dB
Spacing	16.5 MHz	Upper	-28.71 dB
Alternate Channel			
Bandwidth	11 MHz	Lower	-----
Spacing	27.5 MHz	Upper	-----

Modulation Standard: 802.11g (54Mbps)
Channel: 11

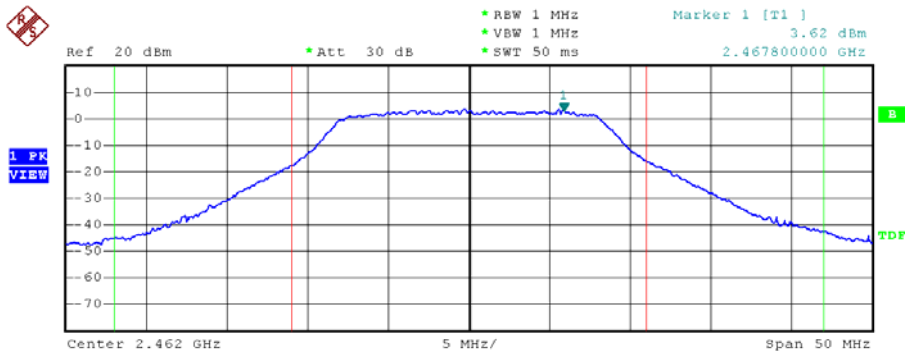

Tx Channel			
Bandwidth	22 MHz	Power	13.71 dBm
Adjacent Channel			
Bandwidth	11 MHz	Lower	-30.79 dB
Spacing	16.5 MHz	Upper	-28.79 dB
Alternate Channel			
Bandwidth	11 MHz	Lower	-----
Spacing	27.5 MHz	Upper	-----



8. Band Edges Measurement

8.1 Test Limit

Below -20dB of the highest emission level of operating band (In 100 kHz Resolution Bandwidth)

8.2 Test Procedure

- The transmitter output was connected to the spectrum analyzer via a low lose cable.
- Set both RBW and VBW of spectrum analyzer to 100 KHz with convenient frequency span including 100 KHz bandwidth from band edge.
- The band edges was measured and recorded.

8.3 Test Setup Layout

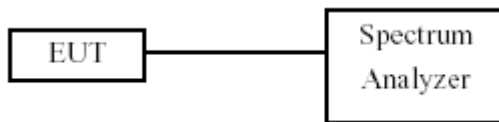

8.4 Measurement equipment

Instrument/Ancillary	Model No.	Manufacturer	Serial No.	Calibration Date	Valid Date
Spectrum Analyzer	FSP40	R&S	10047	2009/03/26	2010/03/25

8.5 Test Result and Data

Test Date: Jun. 12, 2009

Temperature: 25°C

Atmospheric pressure: 1015 hPa

Humidity: 65%

Modulation Standard	Channel	Frequency (MHz)	maximum value in frequency (MHz)	maximum value (dBm)
802.11b (11Mbps)	01	2412	2392	-34.26
	11	2462	2725	-45.17
802.11g (54Mbps)	01	2412	2392	-34.92
	11	2462	2725	-44.15



Modulation Standard: 802.11b (11Mbps)
Channel: 01

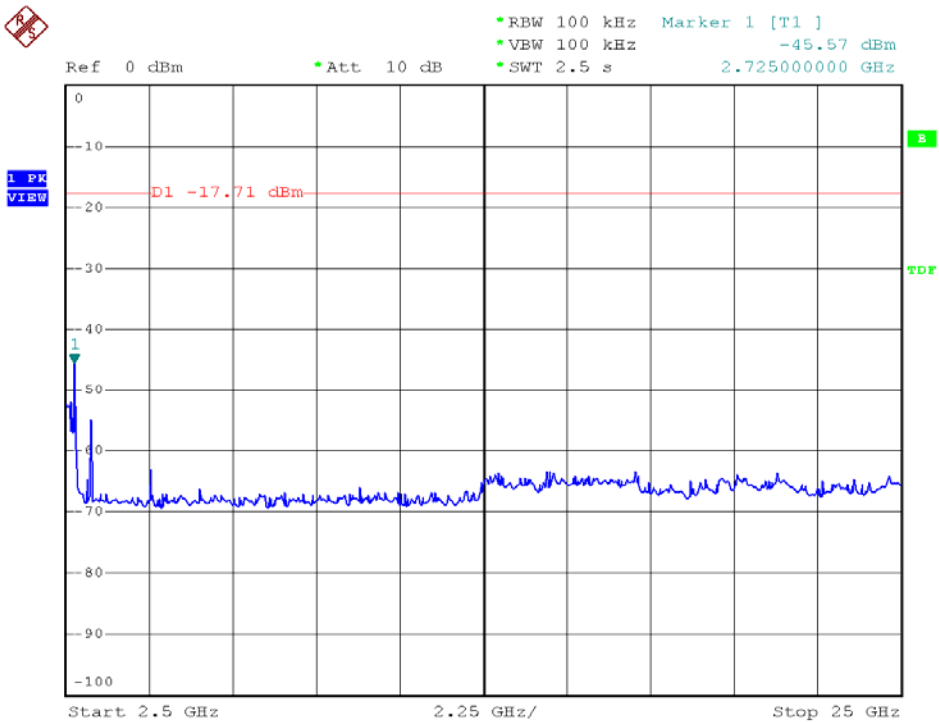
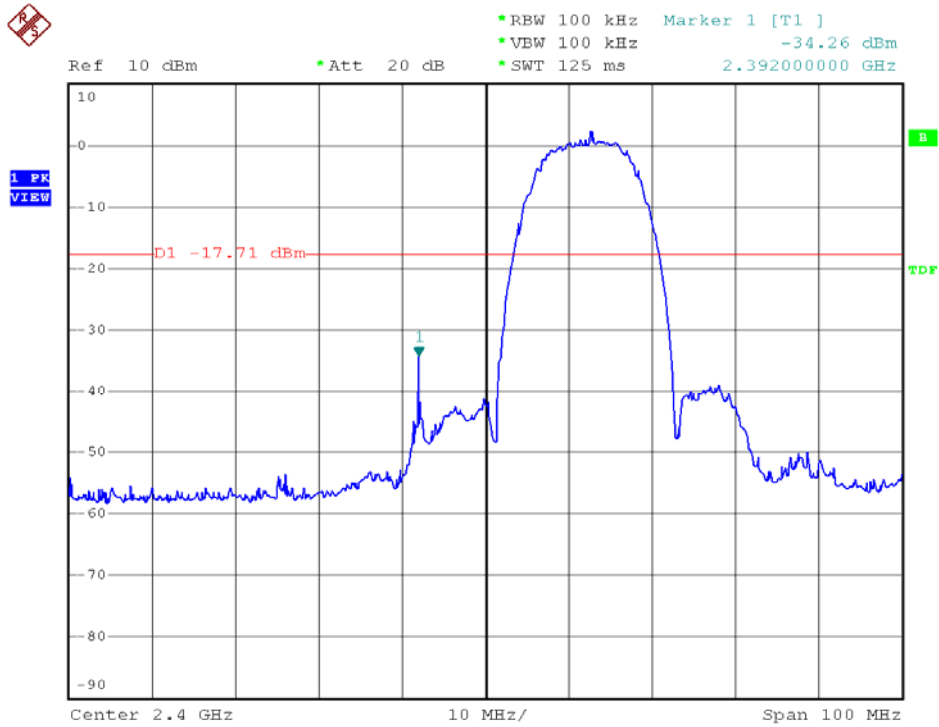



Modulation Standard: 802.11b (11Mbps)
Channel: 11

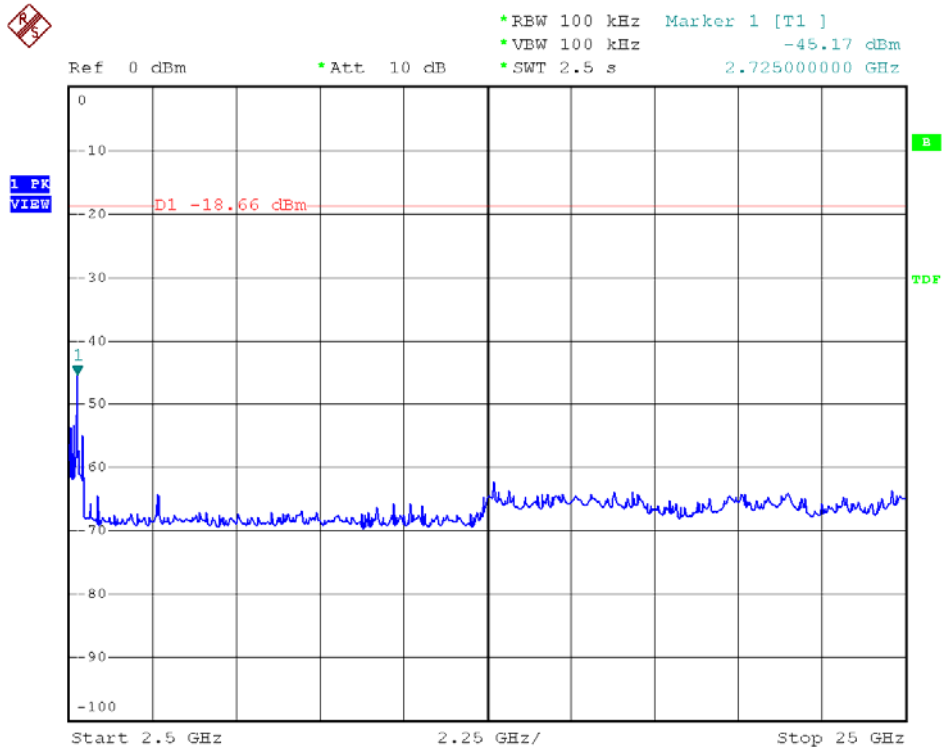
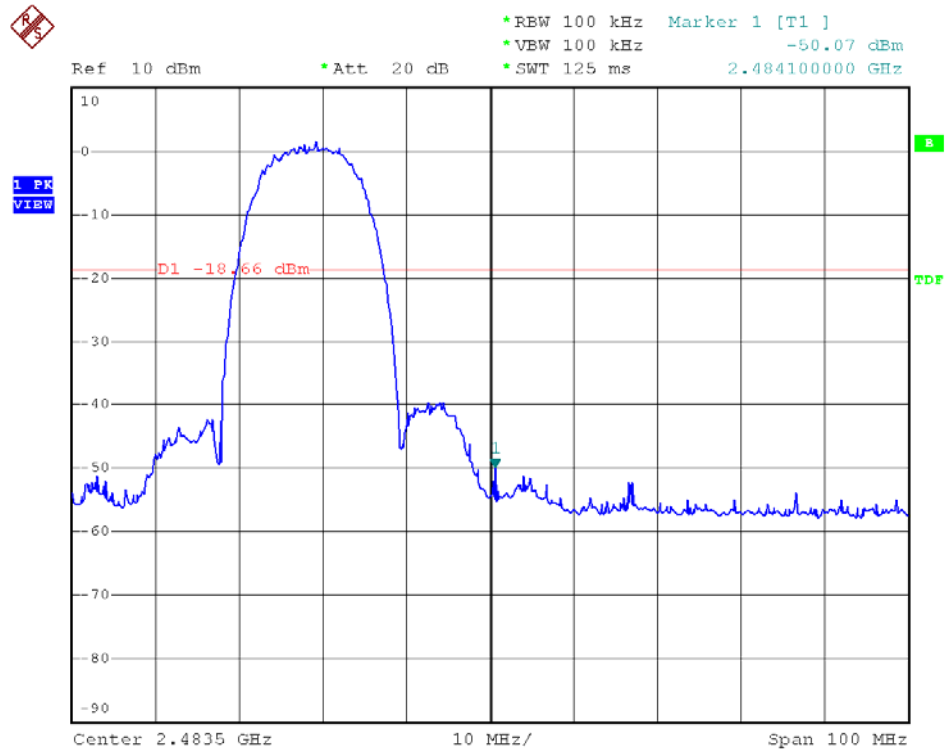



Modulation Standard: 802.11g (54Mbps)
Channel: 01

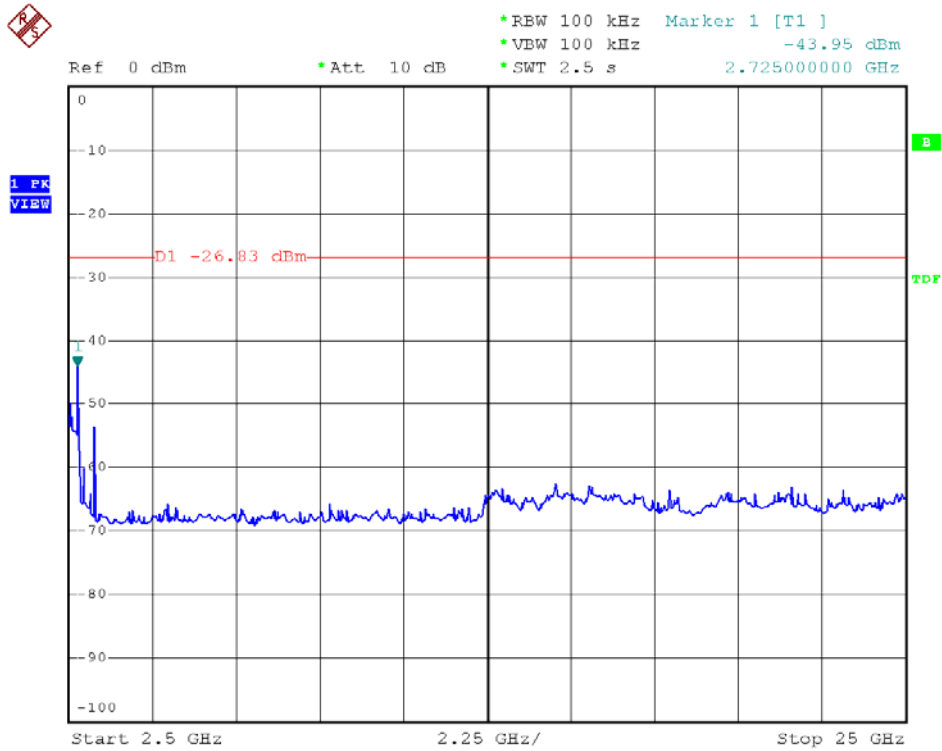
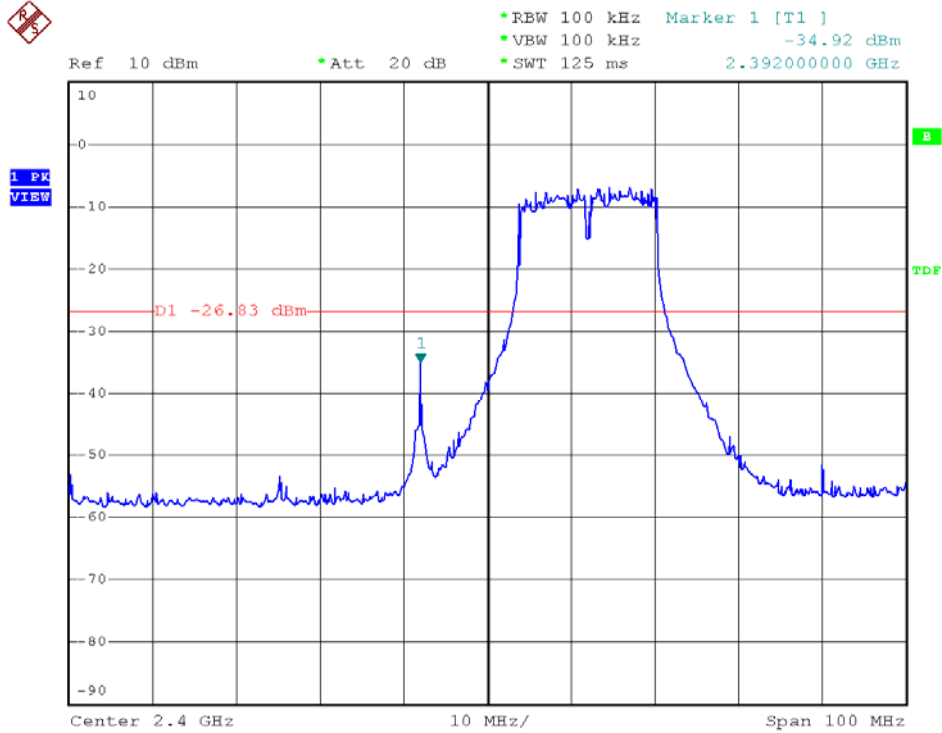



Modulation Standard: 802.11g (54Mbps)
Channel: 11

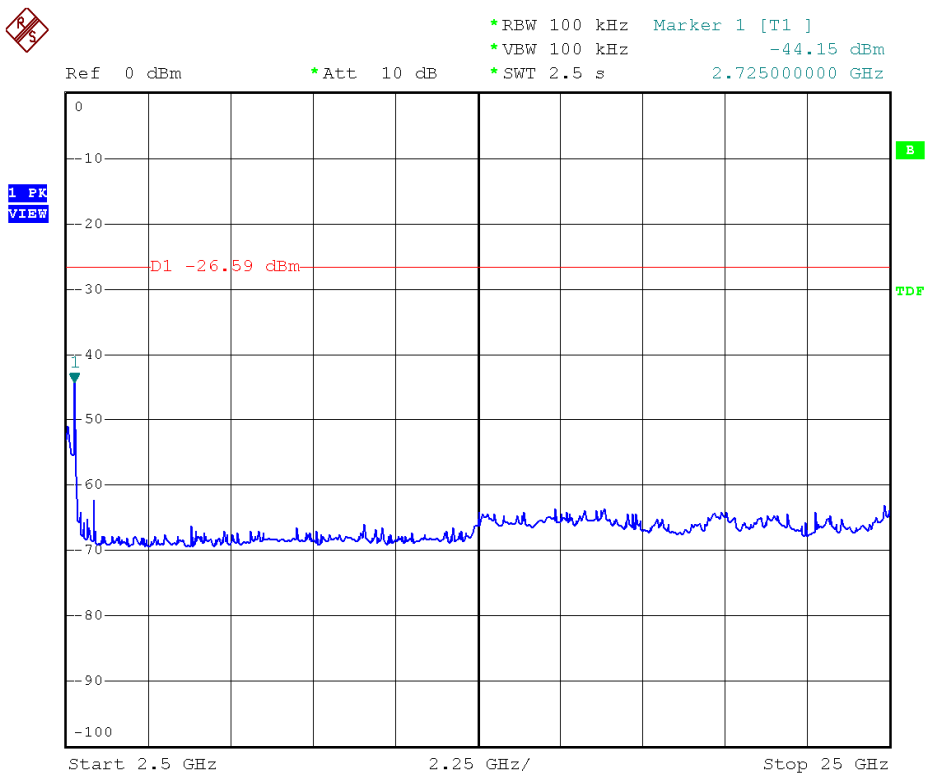
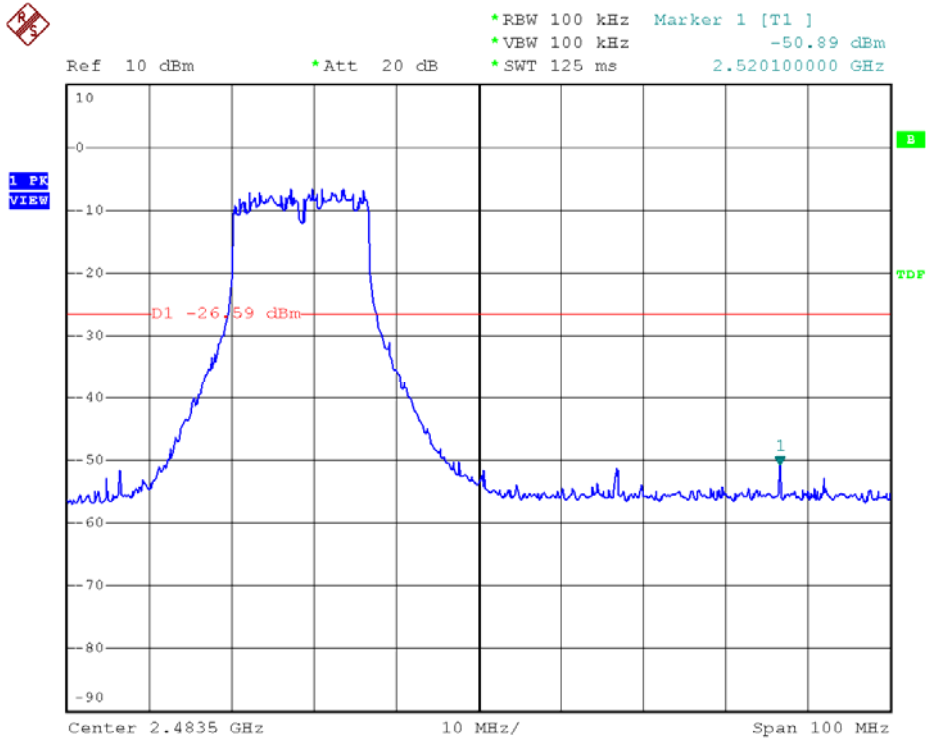

**8.6 Restrict Band Emission Measurement Data**

Test Date : Jun. 12, 2009
 Temperature : 27°C
 Humidity : 64%
 Atmospheric Pressure : 1015 hPa
 Adapter : MU12-G120100-A1

Modulation Standard: IEEE 802.11b (11Mbps)

Channel 1						Fundamental Frequency: 2412 MHz				
Frequency (MHz)	Ant-Pol H/V	Meter Reading	Corrected Factor	Result (dBuV/m)	Remark	Limit@3m (dBuV/m)		Margin (dB)	Table (Deg.)	Ant High (m)
						Peak	Ave.			
2389.866	H	56.926	-4.908	52.018	Peak	74	54	-21.982	219	100
2375.280	H	37.699	-4.958	32.741	Ave	74	54	-21.259	219	100
2389.866	V	60.978	-4.908	56.07	Peak	74	54	-17.930	183	100
2389.866	V	44.993	-4.908	40.085	Ave	74	54	-13.915	183	100
Channel 11						Fundamental Frequency: 2462 MHz				
2483.774	H	59.396	-4.587	54.809	Peak	74	54	-19.191	234	100
2483.85	H	40.477	-4.587	35.89	Ave	74	54	-18.110	234	100
2483.774	V	68.866	-4.587	64.279	Peak	74	54	-9.721	125	100
2483.888	V	51.829	-4.587	47.242	Ave	74	54	-6.758	125	100

Modulation Standard: IEEE 802.11g (54Mbps)

Channel 1						Fundamental Frequency: 2412 MHz				
Frequency (MHz)	Ant-Pol H/V	Meter Reading	Corrected Factor	Result (dBuV/m)	Remark	Limit@3m (dBuV/m)		Margin (dB)	Table (Deg.)	Ant High (m)
						Peak	Ave.			
2389.866	H	51.47	-4.908	46.562	Peak	74	54	-27.438	77	100
2389.866	H	38.436	-4.908	33.528	Ave	74	54	-20.472	77	100
2389.560	V	55.352	-4.909	50.443	Peak	74	54	-23.557	0	100
2331.930	V	38.569	-5.107	33.462	Ave	74	54	-20.538	0	100
Channel 11						Fundamental Frequency: 2462 MHz				
2483.926	H	60.069	-4.587	55.482	Peak	74	54	-18.518	116	100
2483.926	H	44.13	-4.587	39.543	Ave	74	54	-14.457	116	100
2484.116	V	66.097	-4.586	61.511	Peak	74	54	-12.489	219	100
2483.926	V	50.03	-4.587	45.443	Ave	74	54	-8.557	219	100

Notes:

1. Result = Meter Reading + Factor
2. Factor = Antenna Factor + Cable Loss – Amplifier
3. The resolution bandwidth of test receiver/spectrum analyzer is 1 MHz and video bandwidth is 3 MHz for Peak detection at frequency above 1GHz.
4. The resolution bandwidth of test receiver/spectrum analyzer is 1MHz and video bandwidth is 10Hz for Average detection at frequency above 1GHz



Test Date : Jun. 12, 2009
 Temperature : 27°C
 Humidity : 64%
 Atmospheric Pressure : 1015 hPa
 Adapter : RHN-120100-1-3

Modulation Standard: IEEE 802.11b (11Mbps)

Channel 1						Fundamental Frequency: 2412 MHz				
Frequency (MHz)	Ant-Pol H/V	Meter Reading	Corrected Factor	Result (dBuV/m)	Remark	Limit@3m (dBuV/m)		Margin (dB)	Table (Deg.)	Ant High (m)
						Peak	Ave.			
2388.744	H	52.406	-4.912	33.283	Peak	74	54	-20.717	104	200
2389.866	H	38.191	-4.908	47.494	Ave	74	54	-26.506	104	200
2389.866	V	62.668	-4.908	57.76	Peak	74	54	-16.240	131	100
2389.866	V	49.049	-4.908	44.141	Ave	74	54	-9.859	131	100
Channel 11						Fundamental Frequency: 2462 MHz				
2483.436	H	56.927	-4.567	52.36	Peak	74	54	-21.640	120	100
2483.964	H	43.921	-4.587	39.334	Ave	74	54	-14.666	120	100
2487.992	V	63.623	-4.572	59.051	Peak	74	54	-14.949	128	100
2483.964	V	50.494	-4.587	45.907	Ave	74	54	-8.093	128	100

Modulation Standard: IEEE 802.11g (54Mbps)

Channel 1						Fundamental Frequency: 2412 MHz				
Frequency (MHz)	Ant-Pol H/V	Meter Reading	Corrected Factor	Result (dBuV/m)	Remark	Limit@3m (dBuV/m)		Margin (dB)	Table (Deg.)	Ant High (m)
						Peak	Ave.			
2389.866	H	53.921	-4.908	49.013	Peak	74	54	-24.987	122	100
2375.382	H	39.788	-4.958	34.83	Ave	74	54	-19.170	122	100
2389.764	V	62.536	-4.909	57.627	Peak	74	54	-16.373	128	100
2389.866	V	48.789	-4.908	43.881	Ave	74	54	-10.119	128	100
Channel 11						Fundamental Frequency: 2462 MHz				
2483.926	H	58.797	-4.587	54.21	Peak	74	54	-19.790	122	100
2483.926	H	43.233	-4.587	38.646	Ave	74	54	-15.354	122	100
2483.888	V	66.755	-4.587	62.168	Peak	74	54	-11.832	128	100
2483.964	V	49.1	-4.587	44.513	Ave	74	54	-9.487	128	100

Notes:

1. Result = Meter Reading + Factor
2. Factor = Antenna Factor + Cable Loss – Amplifier
3. The resolution bandwidth of test receiver/spectrum analyzer is 1 MHz and video bandwidth is 3 MHz for Peak detection at frequency above 1GHz.
4. The resolution bandwidth of test receiver/spectrum analyzer is 1MHz and video bandwidth is 10Hz for Average detection at frequency above 1GHz



9. Power Spectral Density

9.1 Test Limit

The Maximum of Power Spectral Density Measurement is 8dBm.

9.2 Test Procedures

- The transmitter output was connected to spectrum analyzer.
- The spectrum analyzer's resolution bandwidth were set at 3KHz RBW and 30KHz VBW as that of the fundamental frequency. Set the sweep time=span/3KHz.
- The power spectral density was measured and recorded.
- The Sweep time is allowed to be longer than span/3KHz for a full response of the mixer in the spectrum analyzer.

9.3 Test Setup Layout

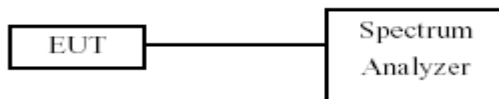

9.4 Measurement equipment

Instrument/Ancillary	Model No.	Manufacturer	Serial No.	Calibration Date	Valid Date
Spectrum Analyzer	FSP40	R&S	10047	2009/03/26	2010/03/25

9.5 Test Result and Data

Test Date: Jun. 12, 2009

Temperature: 25°C

Atmospheric pressure: 1015 hPa

Humidity: 65%

Modulation Standard	Channel	Frequency (MHz)	Maximum Power Density of 3 kHz Bandwidth (dBm)
802.11b (11Mbps)	01	2412	-11.03
	06	2437	-9.16
	11	2462	-9.02
802.11g (54Mbps)	01	2412	-20.29
	06	2437	-20.49
	11	2462	-16.56



Modulation Standard: 802.11b (11Mbps)
Channel: 01

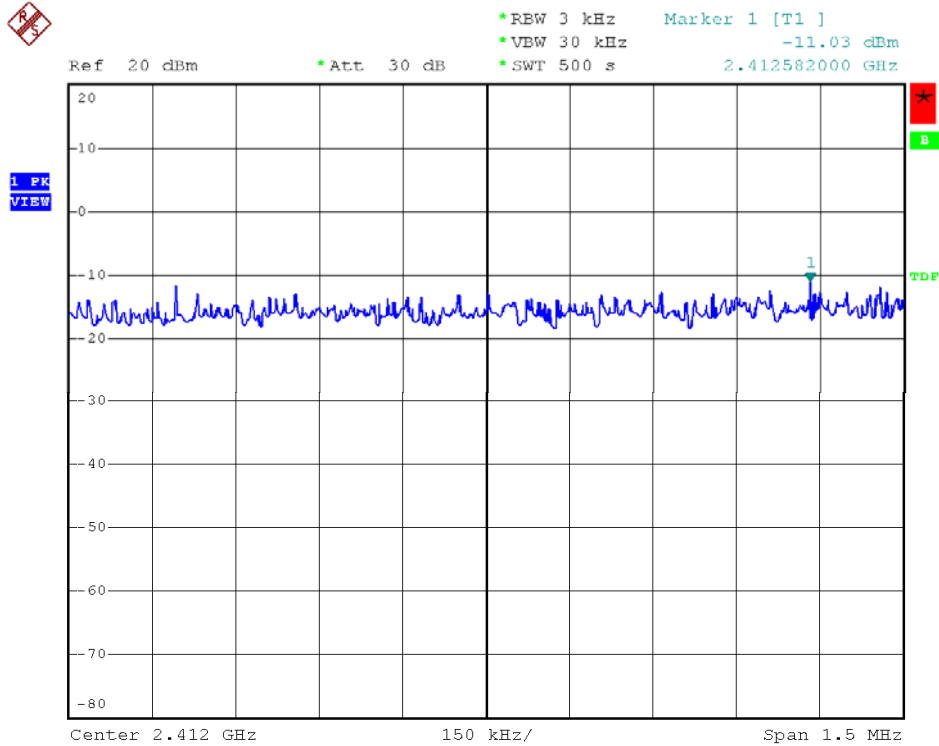

Modulation Standard: 802.11b (11Mbps)
Channel: 06

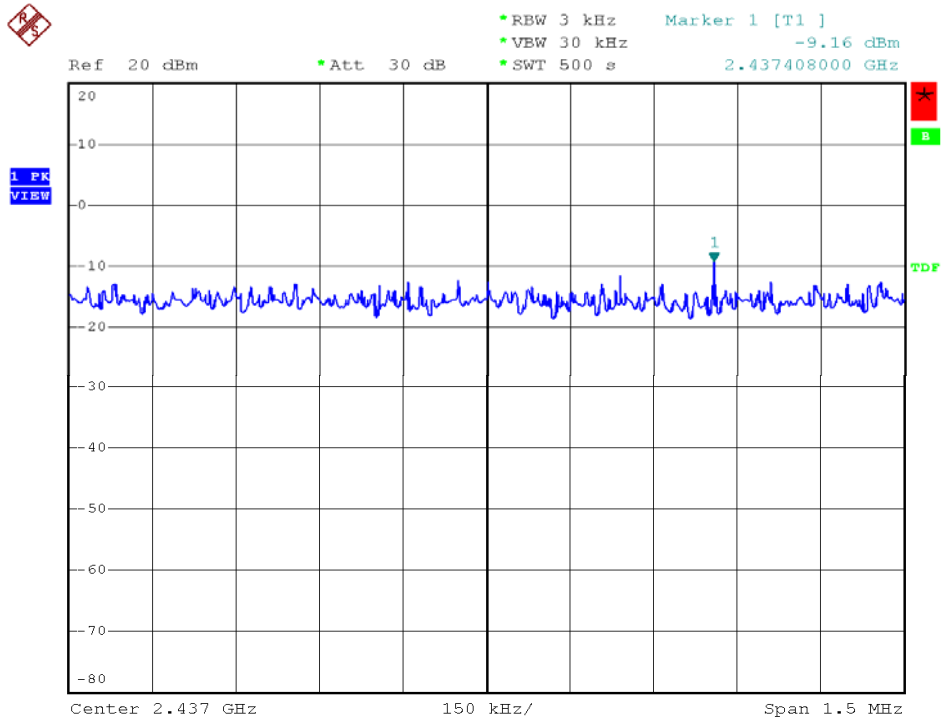



Modulation Standard: 802.11b (11Mbps)
Channel: 11

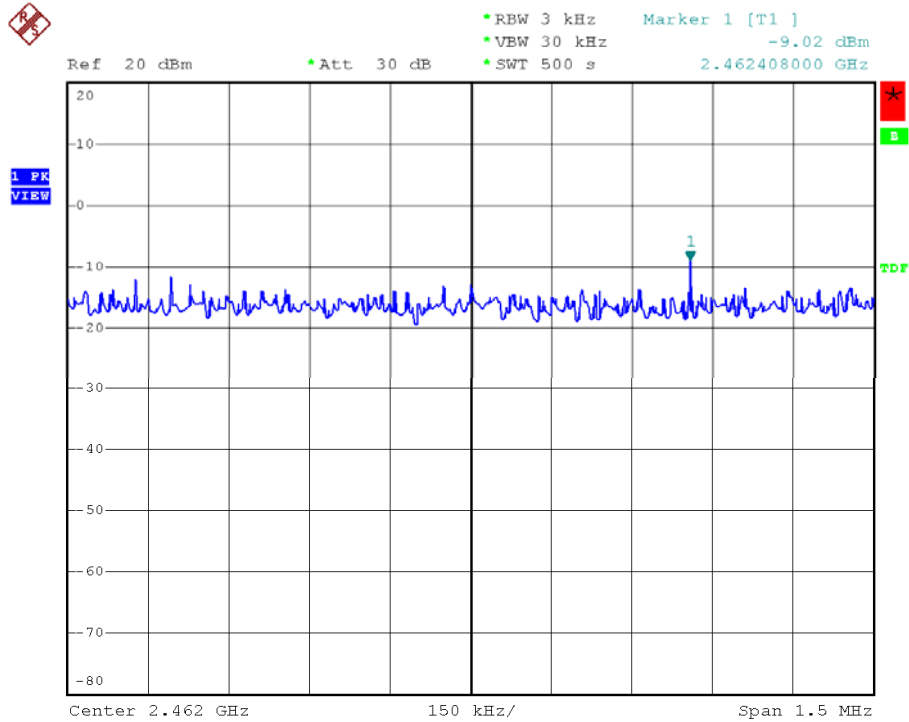

Modulation Standard: 802.11g (54Mbps)
Channel: 01

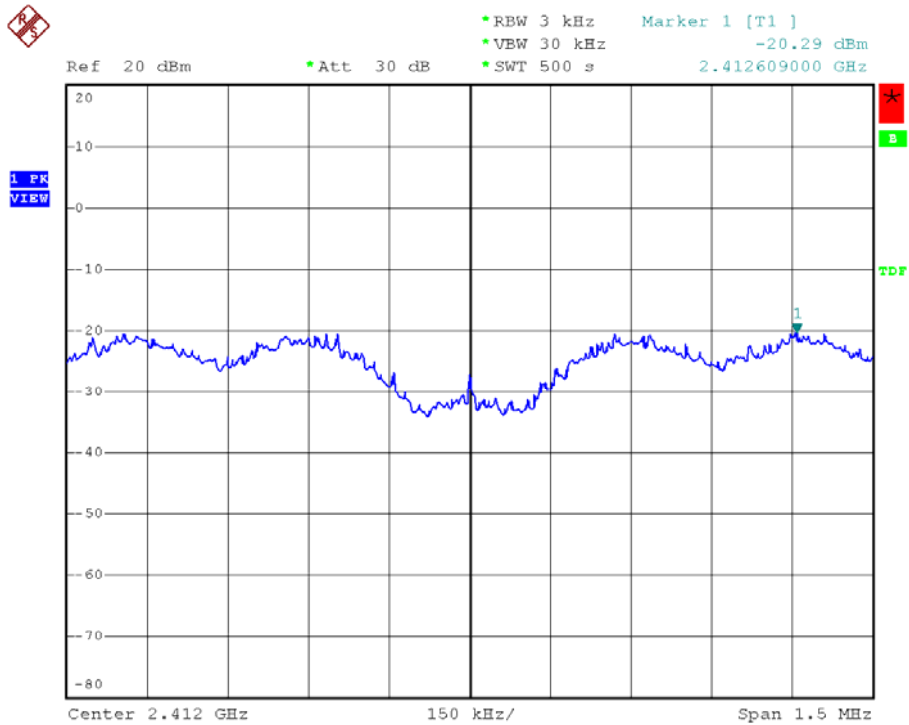



Modulation Standard: 802.11g (54Mbps)
Channel: 06

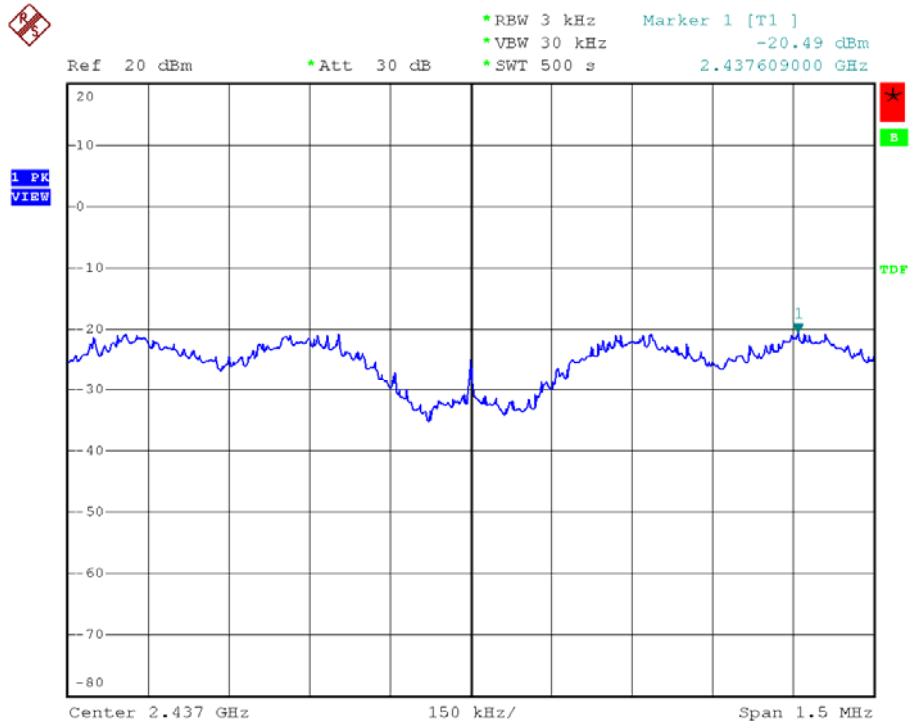

Modulation Standard: 802.11g (54Mbps)
Channel: 11

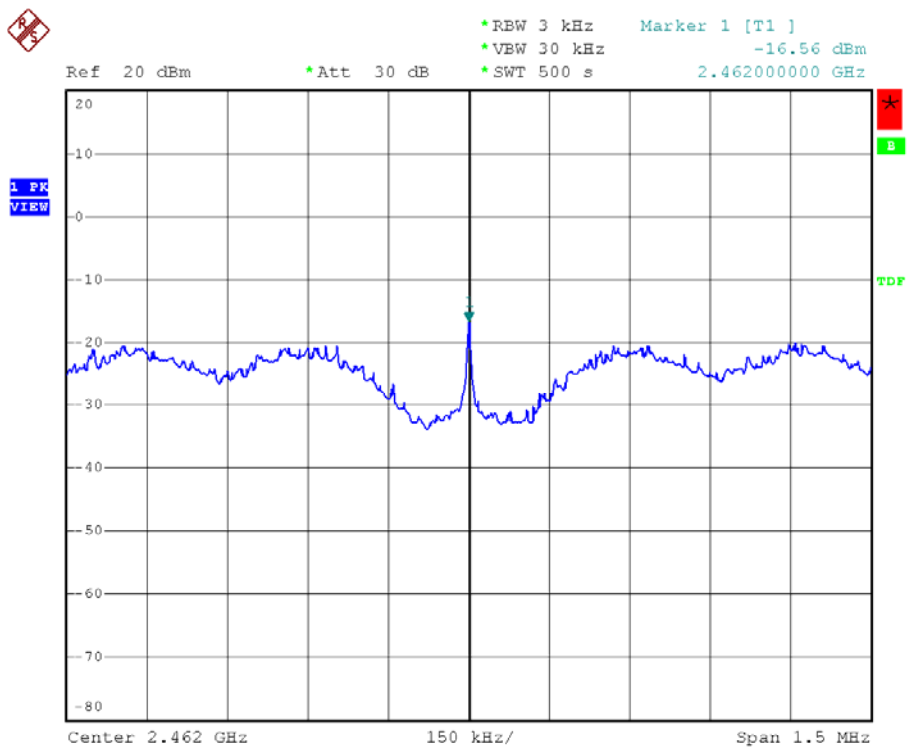



10. Restricted Bands of Operation

Only spurious emissions are permitted in any of the frequency bands listed below:

MHz	MHz	MHz	GHz
0.09000 – 0.11000	16.42000 – 16.42300	399.9 – 410.0	4.500 – 5.250
0.49500 – 0.505**	16.69475 – 16.69525	608.0 – 614.0	5.350 – 5.460
2.17350 – 2.19050	16.80425 – 16.80475	960.0 – 1240.0	7.250 – 7.750
4.12500 – 4.12800	25.50000 – 25.67000	1300.0 – 1427.0	8.025 – 8.500
4.17725 – 4.17775	37.50000 – 38.25000	1435.0 – 1626.5	9.000 – 9.200
4.20725 – 4.20775	73.00000 – 74.60000	1645.5 – 1646.5	9.300 – 9.500
6.21500 – 6.21800	74.80000 – 75.20000	1660.0 – 1710.0	10.600 – 12.700
6.26775 – 6.26825	108.00000 – 121.94000	1718.8 – 1722.2	13.250 – 13.400
6.31175 – 6.31225	123.00000 – 138.00000	2200.0 – 2300.0	14.470 – 14.500
8.29100 – 8.29400	149.90000 – 150.05000	2310.0 – 2390.0	15.350 – 16.200
8.36200 – 8.36600	156.52475 – 156.52525	2483.5 – 2500.0	17.700 – 21.400
8.37625 – 8.38675	156.70000 – 156.90000	2655.0 – 2900.0	22.010 – 23.120
8.41425 – 8.41475	162.01250 – 167.17000	3260.0 – 3267.0	23.600 – 24.000
12.29000 – 12.29300	167.72000 – 173.20000	3332.0 – 3339.0	31.200 – 31.800
12.51975 – 12.52025	240.00000 – 285.00000	3345.8 – 3358.0	36.430 – 36.500
12.57675 – 12.57725	322.00000 – 335.40000	3600.0 – 4400.0	Above 38.6
13.36000 – 13.41000			

** : Until February 1, 1999, this restricted band shall be 0.490-0.510 MHz

10.1 Labeling Requirement

The device shall bear the following statement in a conspicuous location on the device:

This device complies with part 15 of the FCC Rules. Operation is subject to the following two conditions: (1) This device may not cause harmful interference, and (2) this device must accept any interference received, including interference that may cause undesired operation.