

TENDA		
W368R		
Title		
Size	Document Number	Rev
B	11-RT3052-RF-A.SCH	0.1
Date:	Thursday, June 18, 2009	Sheet 2 of 14

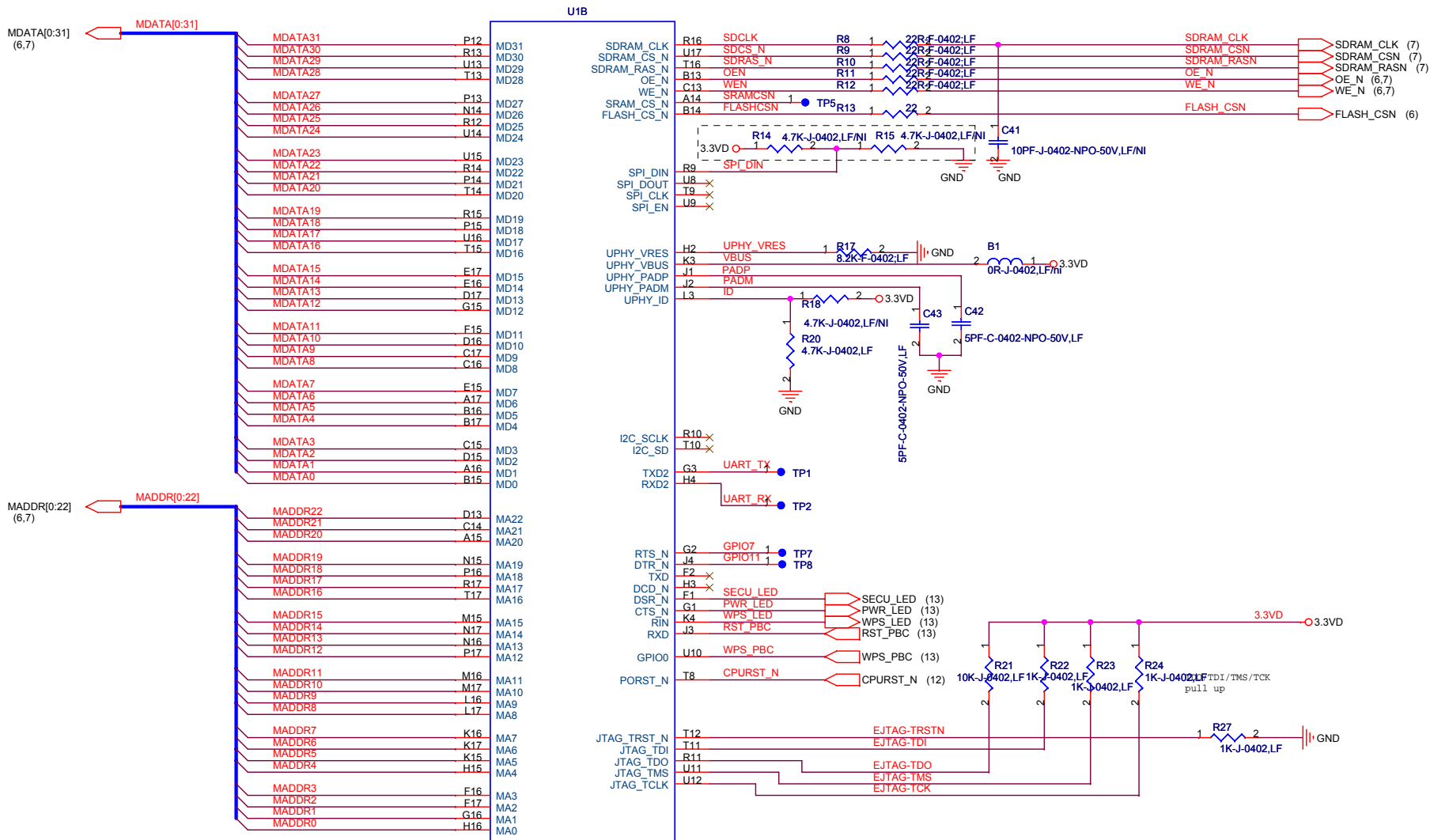

RT3052:11n wlan controller;TPBGA289;Ralink;LF

TENDA		
Title		
W368R		
Size B	Document Number 12-RT3052-Peripheral-B.SCH	Rev 0.1
Date:	Thursday, June 18, 2009	Sheet 3 of 14

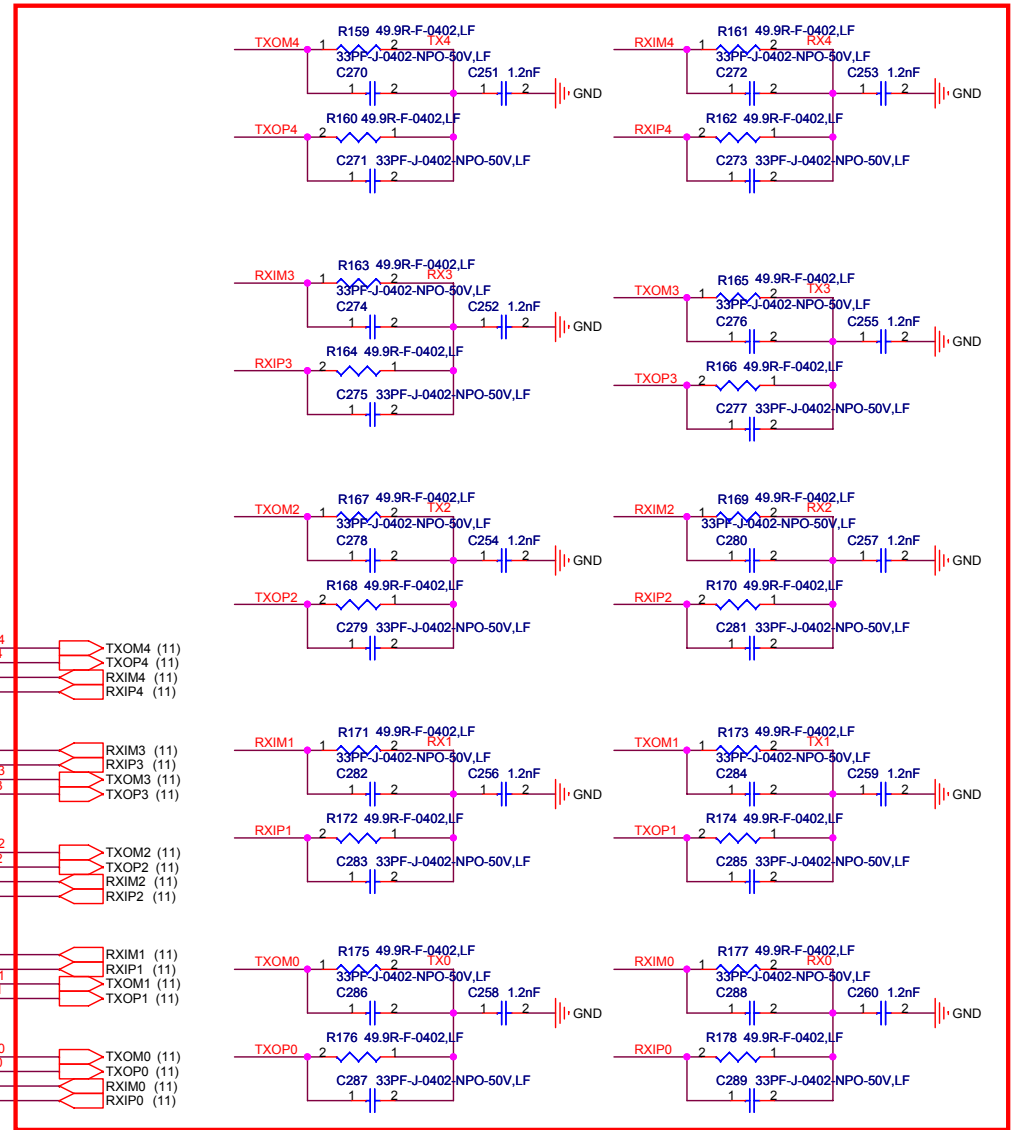
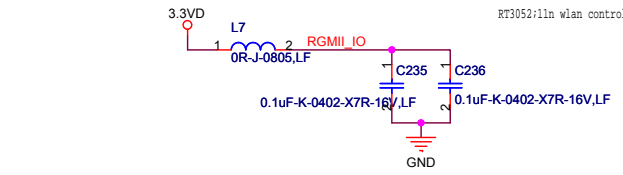
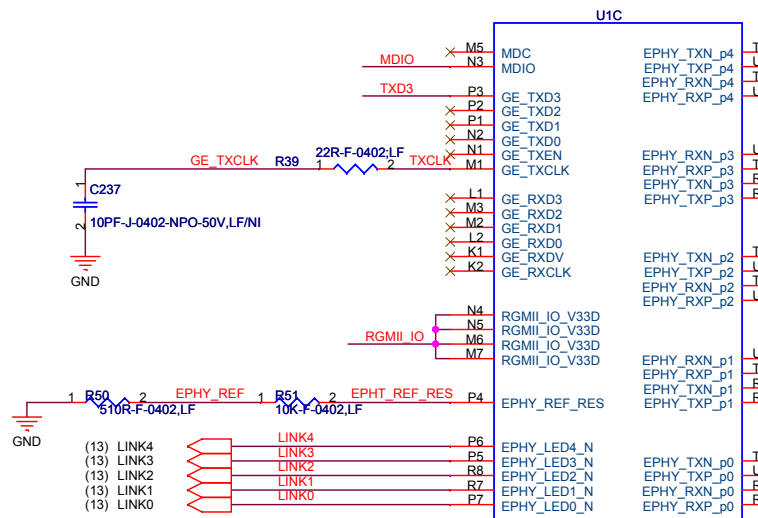

RT3052:11n wlan controller:TPBGA289;RaLink;LF

TENDA		
W368R		
Title		
Size B	Document Number	Rev 0.1
	13-RT3052-Ethernet-C.SCH	
Date:	Thursday, June 18, 2009	Sheet 4 of 14

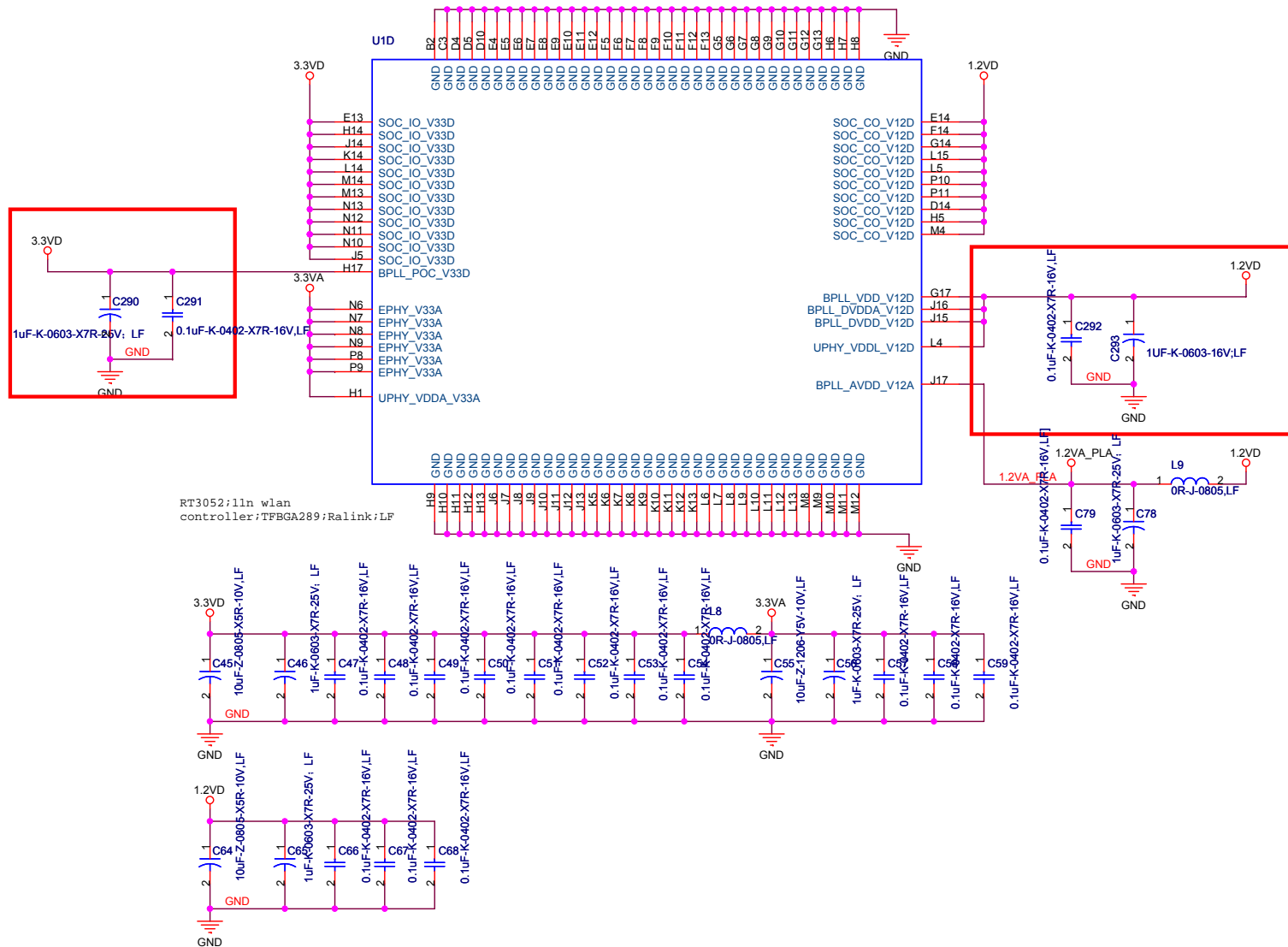

TENDA		
W368R		
Size B	Document Number 14-R3052-Power-D.SCH	Rev 0.1
Date Thursday, June 18, 2009	Sheet 5	of 14

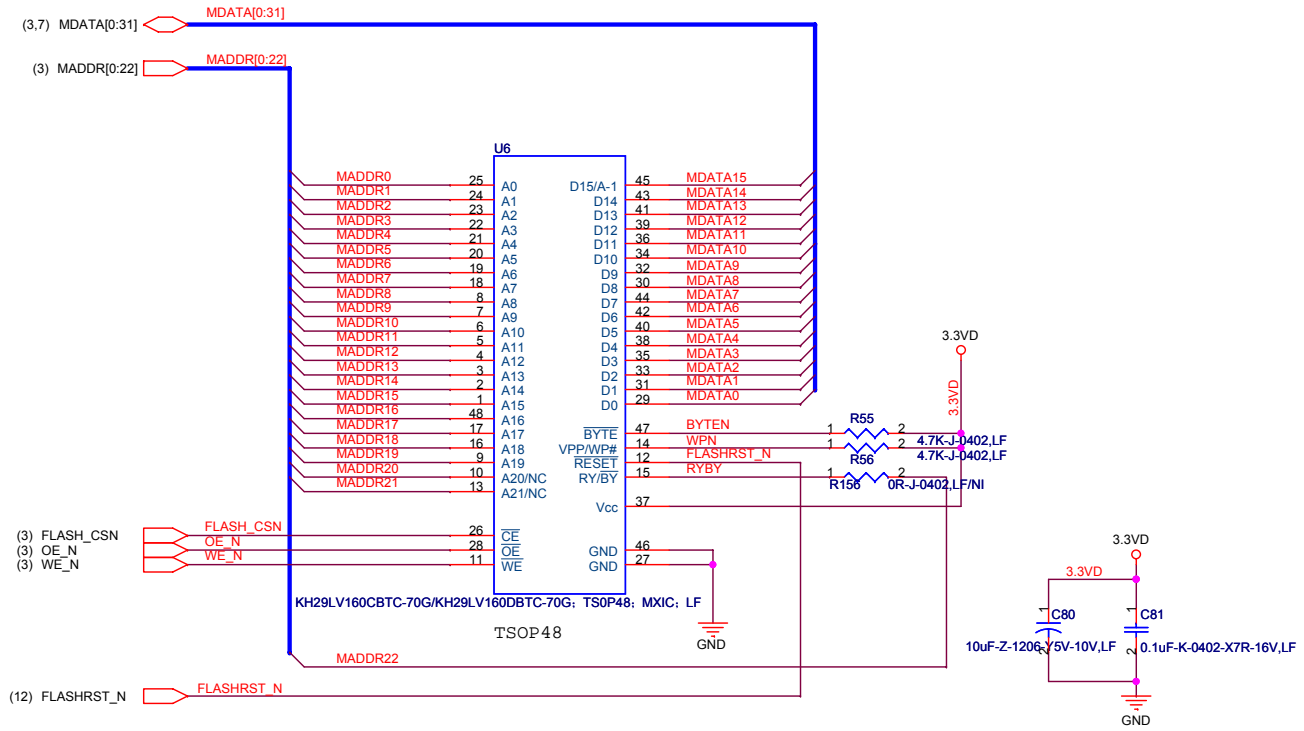

TENDA		
Title		
W368R		
Size	Document Number	Rev
B	21-FALSH.SCH	0.1
Date:	Thursday, June 18, 2009	Sheet 6 of 14

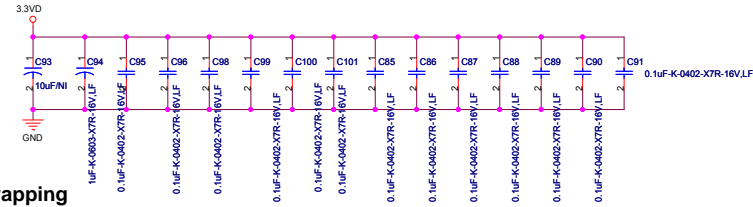
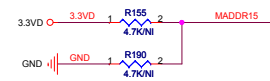
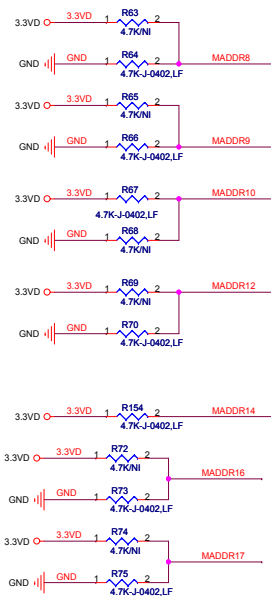
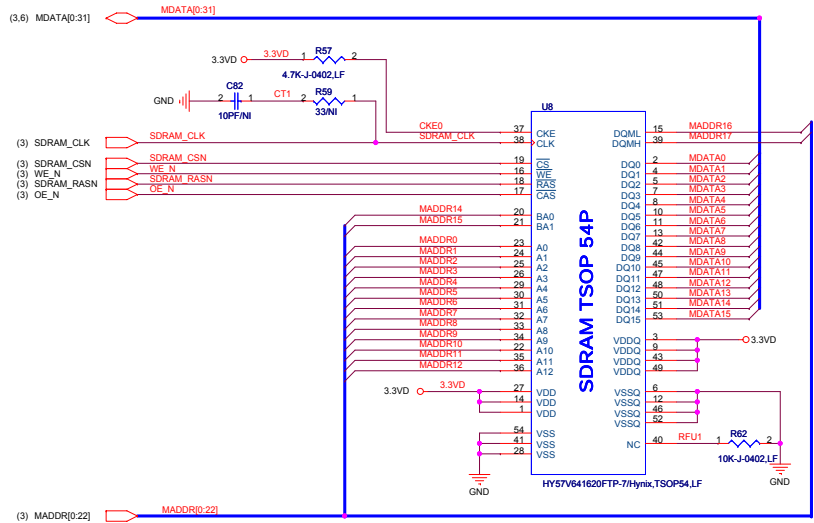

Boot Up Strapping

Pin Name	Description	Value=0	Value=1
MA[9:8]	BOOT FROM	00 : 16bit flash* 01 : 8bit flash 10 : NAND Flash 11: Internal ROM	
MA10	CPU CLK SEL	320Mhz	384Mhz*
MA12	BIG ENDIAN	Little*	Big
MA13	Bypass PLL	Not Bypass*	Bypass
MA14	Boot Addr	0x1FC00000*	0x1F000000
MA15	Reserved		
MA[17:16]	GE MODE	Gagabit Port Mode 00 : RGMII (10/100/1000 bps)* 01 : MII(10/100 bps) 10 : Reversed MII(10/100 bps) 11 : Reversed	
MA18	Reserved		
MA19	Reserved		
MA20	iNIC SDRAM	2MB*	8MB
MA21	iNIC Config	NA	EEPROM /MA20

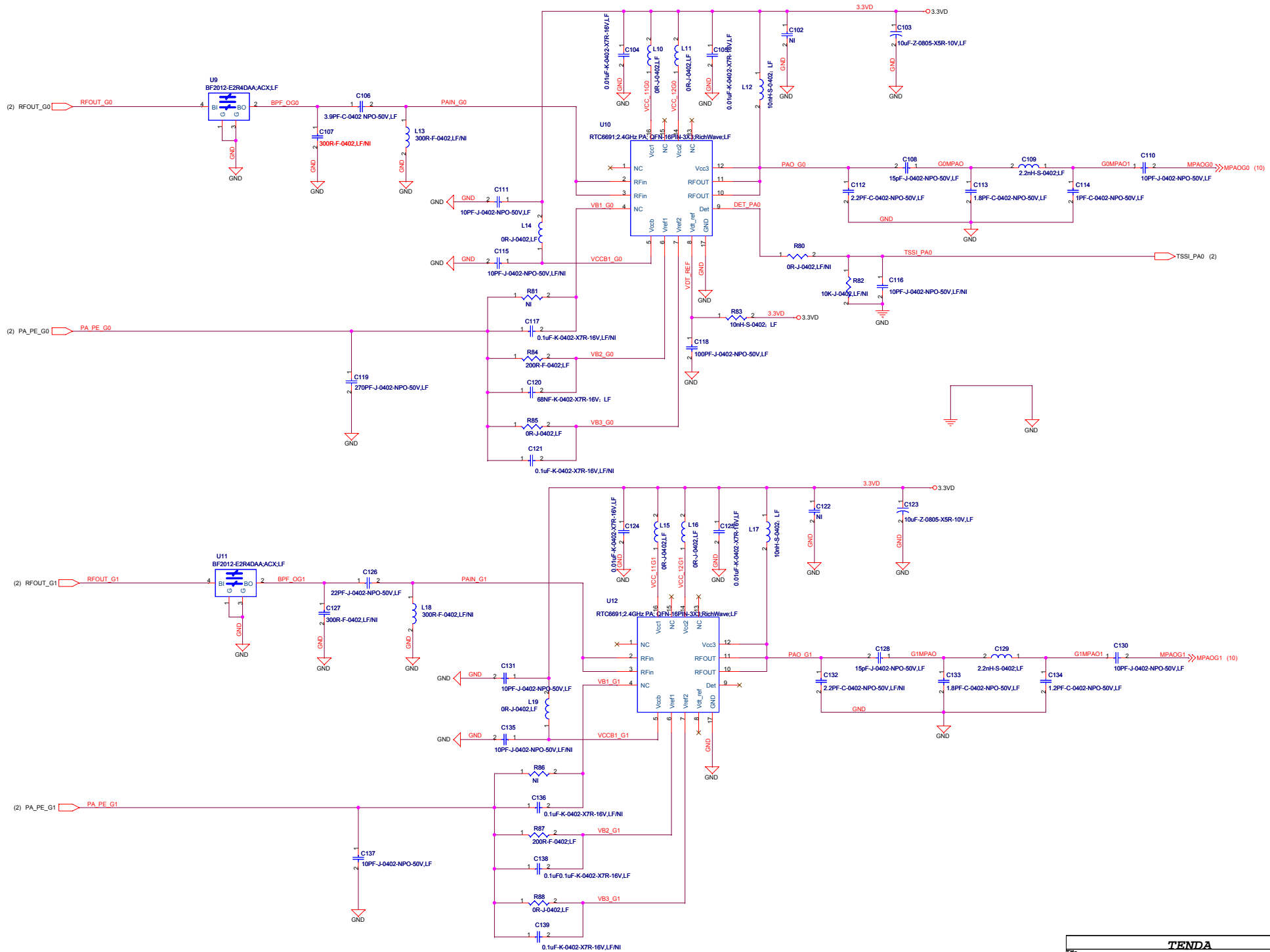

TENDA		
Title	W368R	
Size	Document Number	Rev
C	31-PA-RW.SCH	0.1
Date:	Thursday, June 18, 2009	Sheet 8 of 14

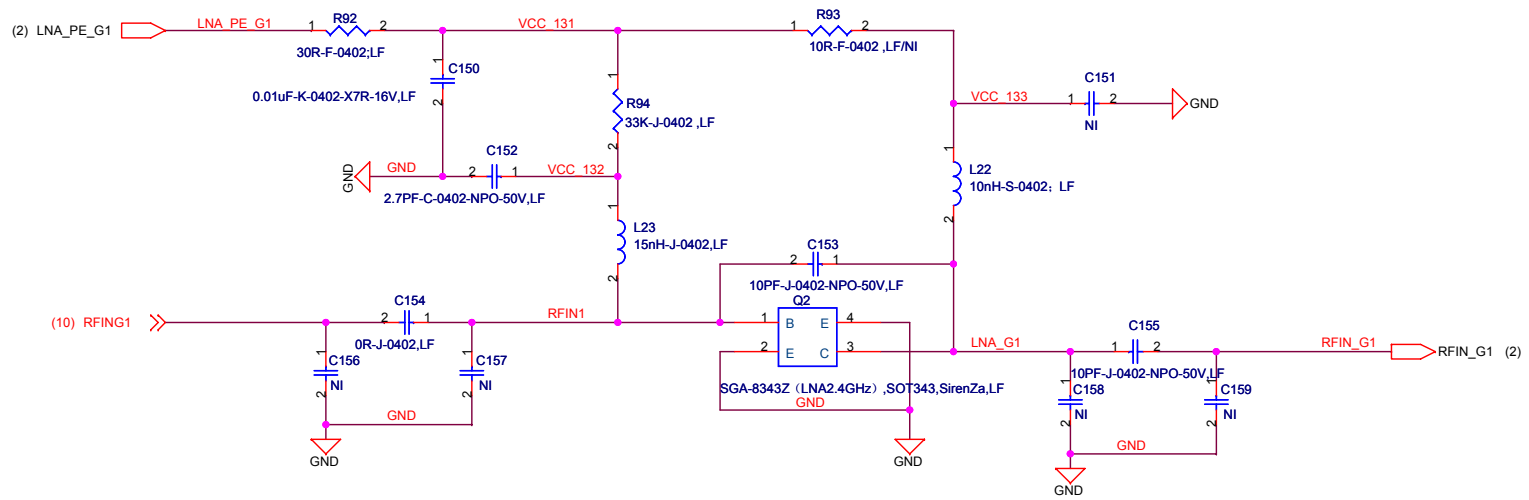
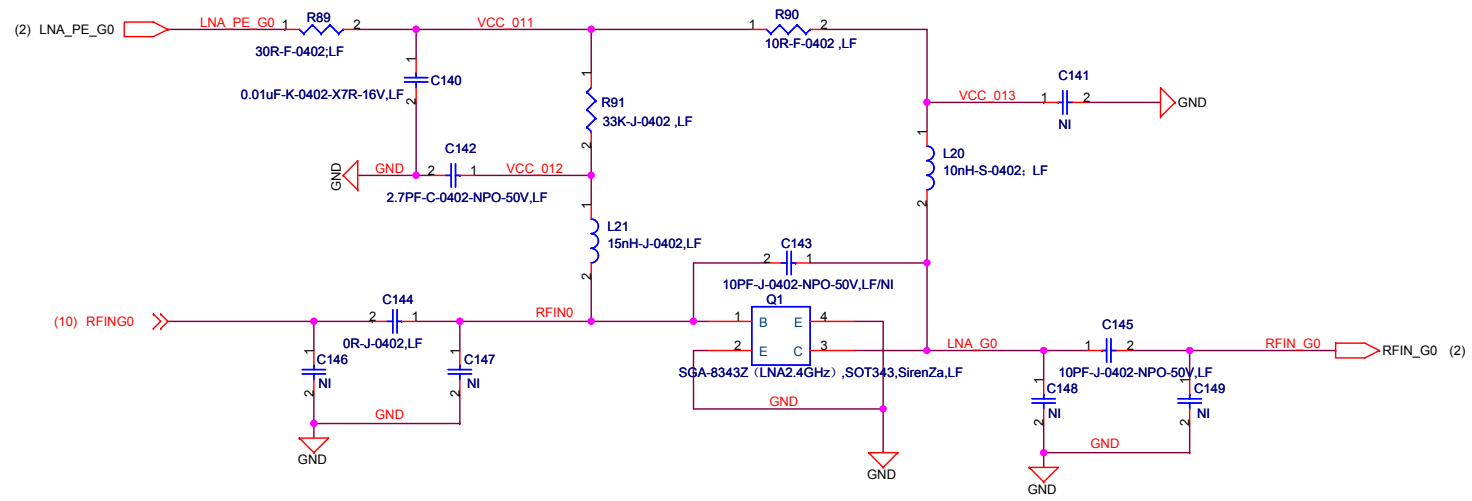

TENDA		
W368R		
Size B	Document Number 32-LNA.SCH	Rev 0.1
Date: Thursday, June 18, 2009	Sheet 9	of 14

Ant. 2412~2462MHz / 2422~2452MHz

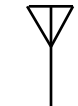

(ANTENNA1)
(TX1/RX1)

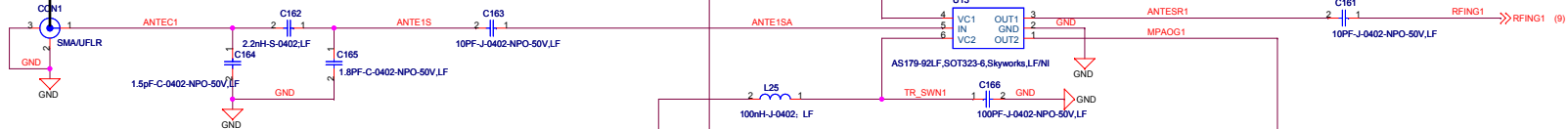

- (2) ANT_TRN → ANT_TRN
- (2) ANT_TRNB → ANT_TRNB

Ant. 2412~2462MHz / 2422~2452MHz

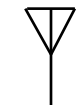

(ANTENNA0)
(TX0/RX0)

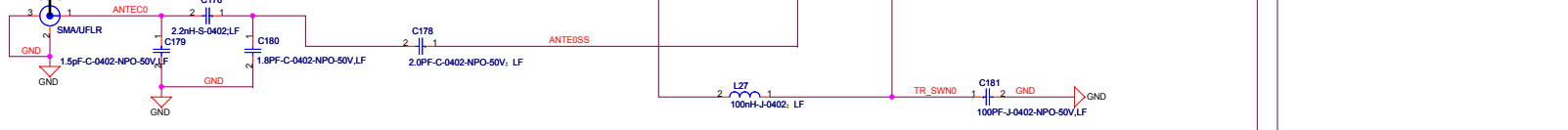

- (8) MPAOG0 → MPAOG0
- (8) MPAOG1 → MPAOG1

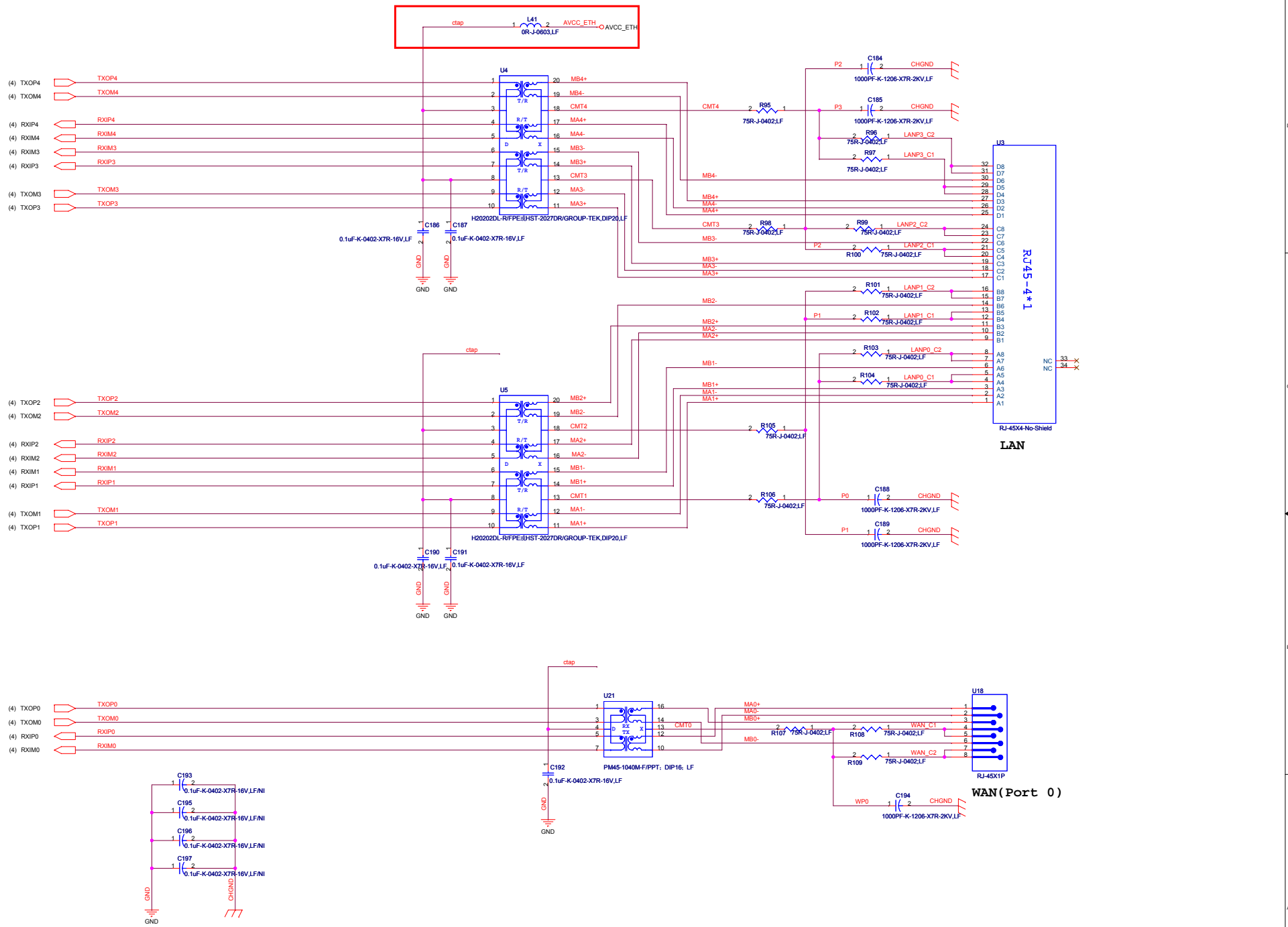

-->3.3V/1.5A

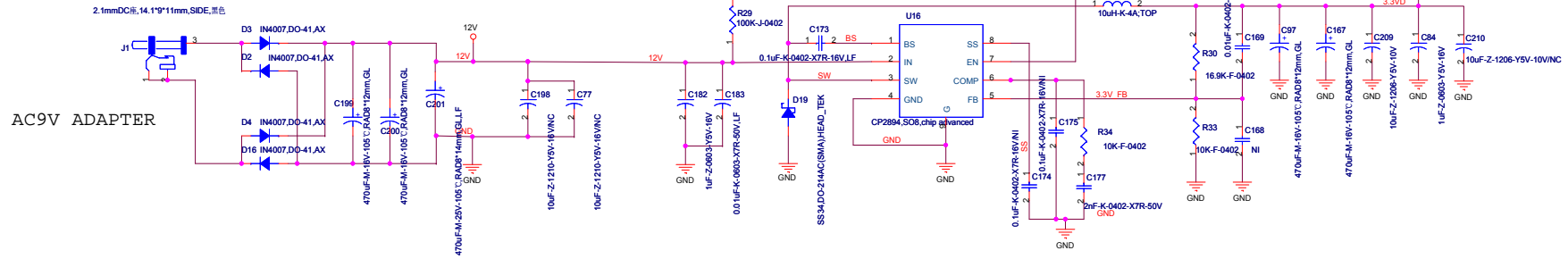

-->1.5V/1.5A

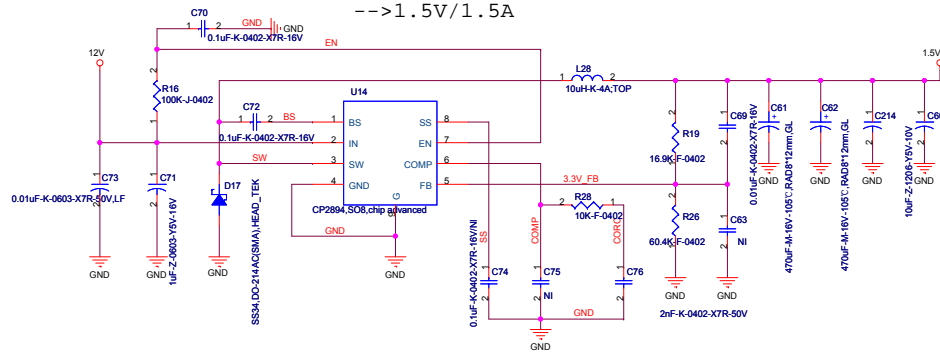

Reset Circuit

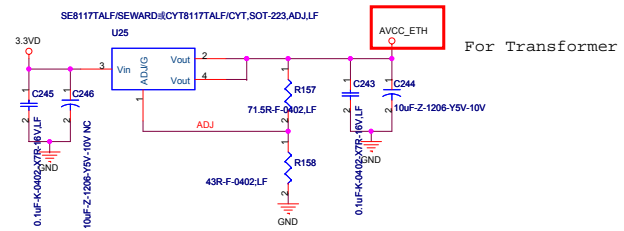
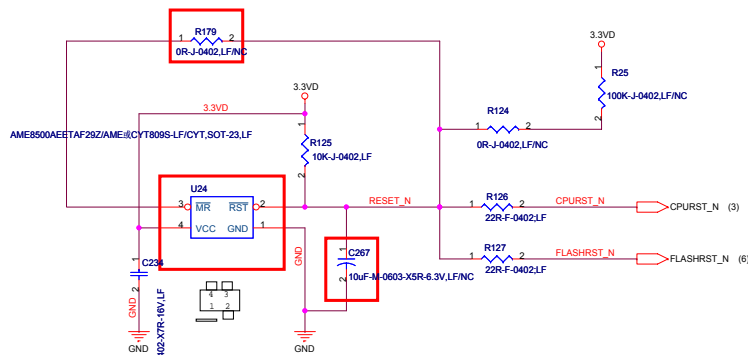

For Transformer

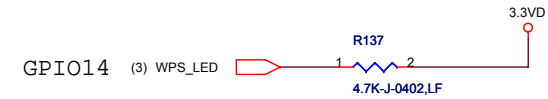
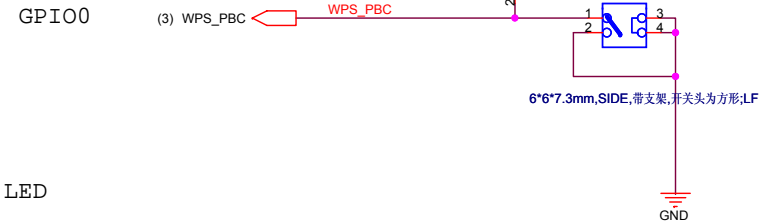
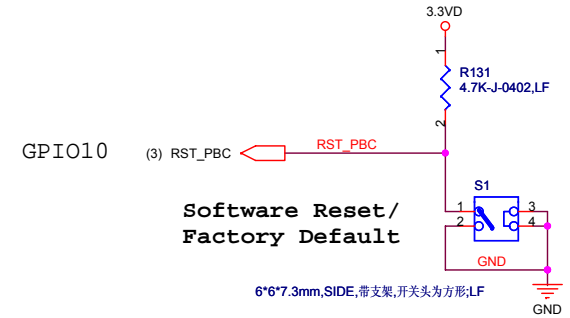
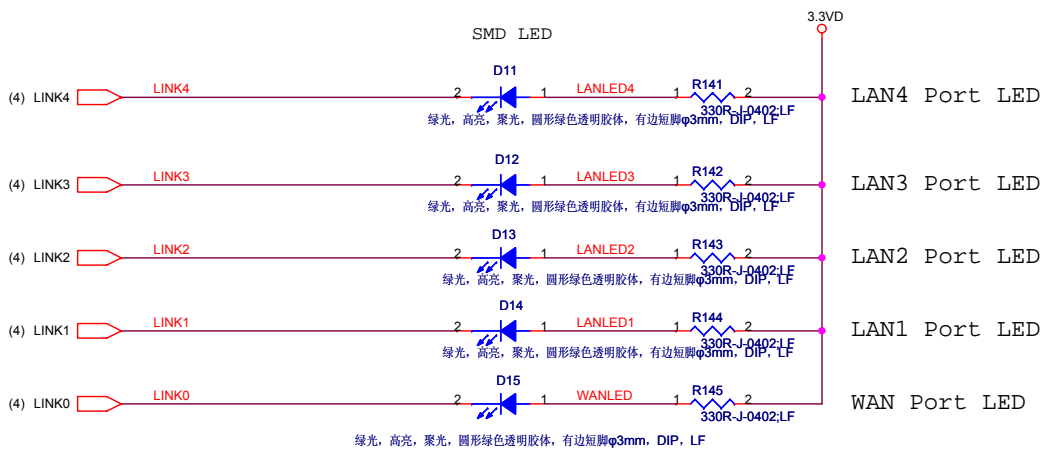
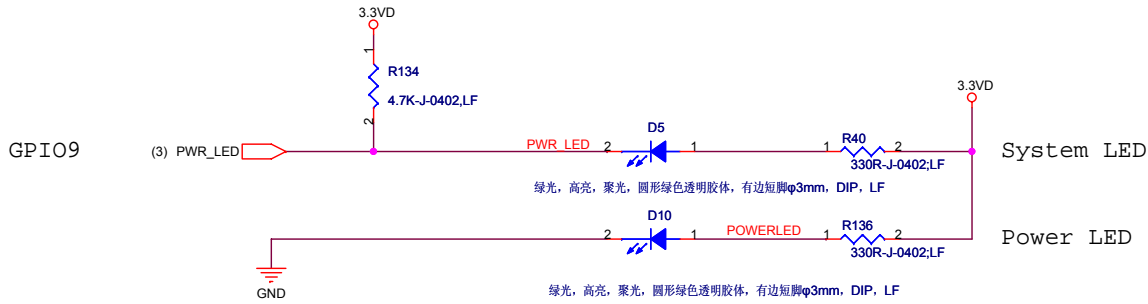
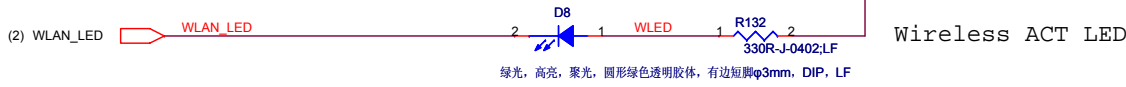
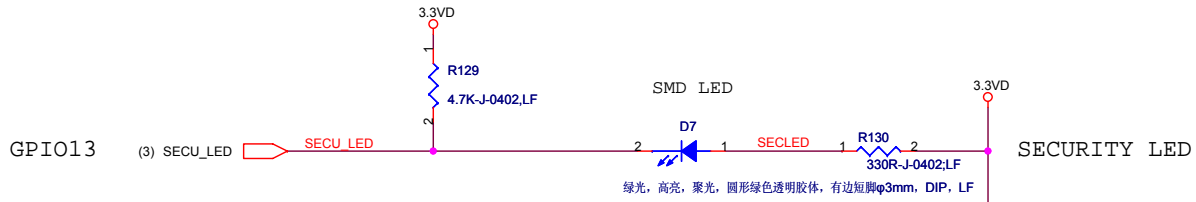

TENDA		
W368R		
Size	Document Number	Rev
B	6-LED.SCH	0.1
Date:	Thursday, June 18, 2009	Sheet 13 of 14

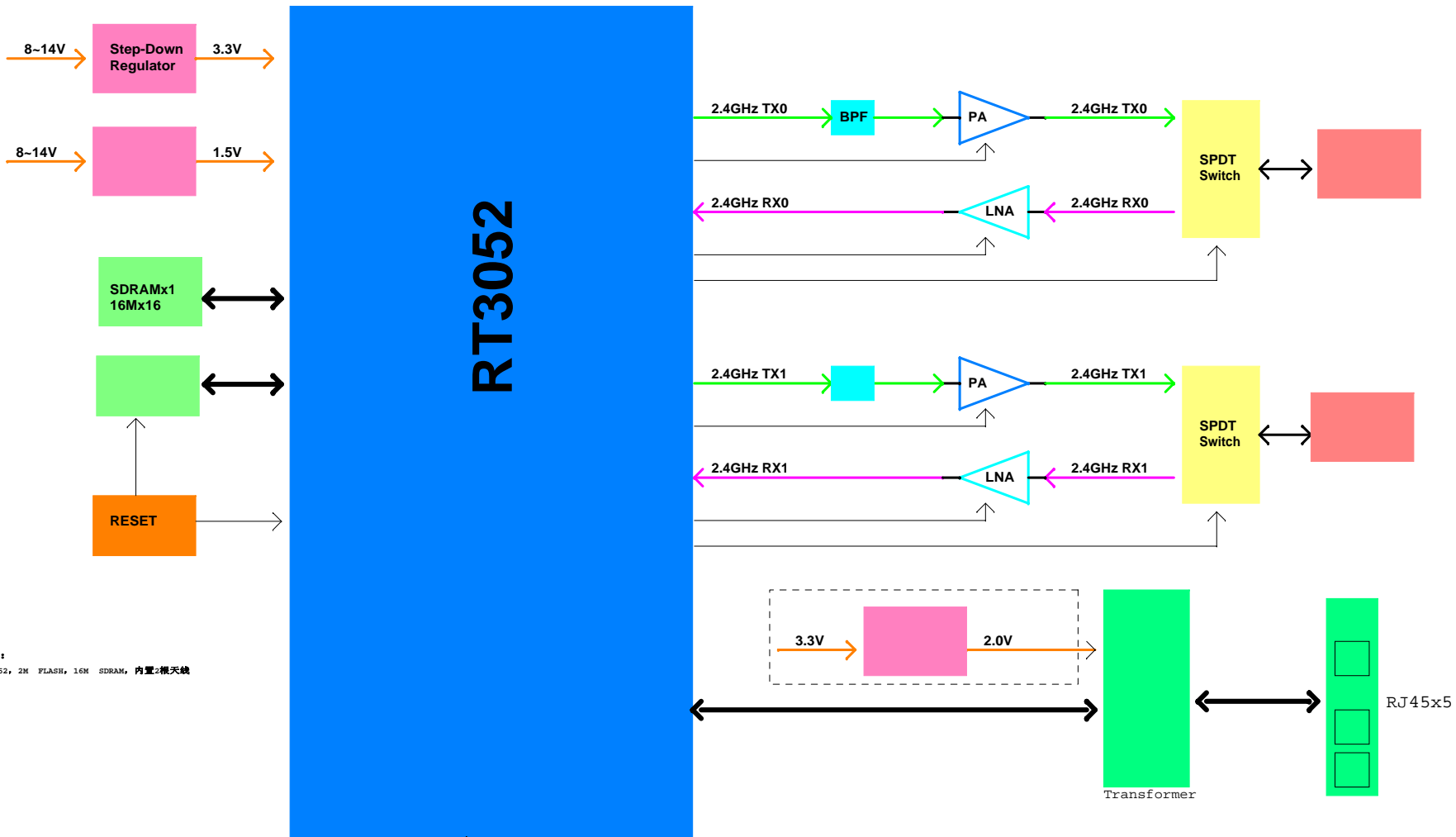

RT3052

产品差异说明:
W368R: 2T2R, RT3052, 2M FLASH, 16M SDRAM, 内置: 根天线

原理说明:

Operational Principle

1. CPU: U1, The RT3052 SOC combines Realtek's 802.11n draft compliant 2T2R(RT3050:1T1R) MAC/BBP/2.4G ISM band Transceiver, a high performance 384MHz MIPS24KEc CPU core, 5-port integrated 10/100 Ethernet switch/PHY; An 40MHz crystal(U2) for CPU S reference frequency;
2. SDRAM: U8, Hynix H57V281620FP-H CMOS Synchronous DRAM, 16M Byte (16M x 16bit x 1PCS)
3. FLASH: U6, MXIC KH29LV320(160)CBTC-70G/MX29LV160CBTC-70G 2M Byte FLASH, used for store firmware and user's settings;
4. PA: U10,U12, Richtek RTC6691, Freq.Range:2.4GHz-2.5GHz. PA For transmitter, Gain:33.5db (Max);
5. LNA: U1, U2, Sirenda SGAR343Z, Freq.Range:2.4GHz-2.5GHz.LNA For RF receiver, Gain:17db (Max);
6. BPF: U9,U11, SF2012-E2R4DA, Freq.Range:2.4GHz-2.5GHz, IL@BW:2.5-3db;
7. RF Switch: U13,U15, skyworks AS179-92, transmit /receive SPDT Switch;
8. Power part: U16 and U14, CP2894 Step-Down PWM Converter, used for transfer DC8-14V to DC3.3V and DC1.5V ; ; U25 SER117TALF LDO used for transfer DC3.3V to DC2.0V;

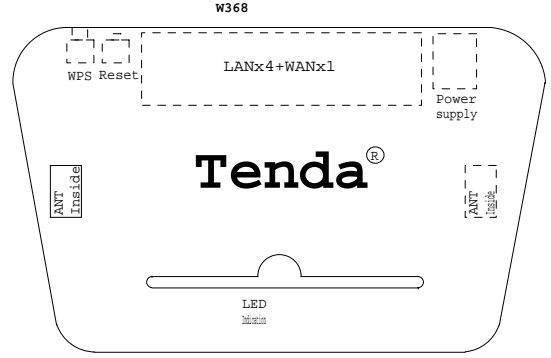

TENDA		
W368R		
Size	Document Number	Rev
C	RT3052 AP Block	0.1
Date:	Thursday, June 18, 2009	Sheet 14 of 14