



**中认信通**  
CHINA CERTIFICATION ICT CO.,LTD (DONGGUAN)



## TEST REPORT

**Applicant:** SHENZHEN TENDA TECHNOLOGY CO.,LTD.

Address: 6-8 Floor, Tower E3, No. 1001, Zhongshanyuan Road, Nanshan District,  
Shenzhen, China. 518052

**FCC ID:** V7TW30E

**Product Name:** AX3000 Dual Band Wi-Fi6 Wireless Hotspot Router

**Standard(s):** 47 CFR Part 15, Subpart C(15.247)  
ANSI C63.10-2013  
KDB 558074 D01 15.247 Meas Guidance v05r02

The above equipment has been tested and found compliant with the requirement of the relative standards  
by China Certification ICT Co., Ltd (Dongguan)

**Report Number:** CR230206428-00A

**Date Of Issue:** 2023/4/10

**Reviewed By:** Sun Zhong

*Sun Zhong*

Title: Manager

**Test Laboratory:** China Certification ICT Co., Ltd (Dongguan)  
No. 113, Pingkang Road, Dalang Town, Dongguan,  
Guangdong, China  
Tel: +86-769-82016888

## Test Facility

The Test site used by China Certification ICT Co., Ltd (Dongguan) to collect test data is located on the No. 113, Pingkang Road, Dalang Town, Dongguan, Guangdong, China.

The lab has been recognized as the FCC accredited lab under the KDB 974614 D01 and is listed in the FCC Public Access Link (PAL) database, FCC Registration No. : 442868, the FCC Designation No. : CN1314.

The lab has been recognized by Innovation, Science and Economic Development Canada to test to Canadian radio equipment requirements, the CAB identifier: CN0123.

## Declarations

China Certification ICT Co., Ltd (Dongguan) is not responsible for the authenticity of any test data provided by the applicant. Data included from the applicant that may affect test results are marked with a triangle symbol “▲”. Customer model name, addresses, names, trademarks etc. are not considered data.

Unless otherwise stated the results shown in this test report refer only to the sample(s) tested.

This report cannot be reproduced except in full, without prior written approval of the Company.

This report is valid only with a valid digital signature. The digital signature may be available only under the Adobe software above version 7.0.

This report may contain data that are not covered by the accreditation scope and shall be marked with an asterisk “★”.

## CONTENTS

<b>TEST FACILITY .....</b>	<b>2</b>
<b>DECLARATIONS.....</b>	<b>2</b>
<b>DOCUMENT REVISION HISTORY .....</b>	<b>5</b>
<b>1. GENERAL INFORMATION.....</b>	<b>6</b>
<b>1.1 PRODUCT DESCRIPTION FOR EQUIPMENT UNDER TEST (EUT) .....</b>	<b>6</b>
<b>1.2 DESCRIPTION OF TEST CONFIGURATION.....</b>	<b>8</b>
1.2.1 EUT Operation Condition:.....	8
1.2.2 Support Equipment List and Details .....	8
1.2.3 Support Cable List and Details .....	9
1.2.4 Block Diagram of Test Setup.....	9
<b>1.3 MEASUREMENT UNCERTAINTY .....</b>	<b>11</b>
<b>2. SUMMARY OF TEST RESULTS.....</b>	<b>12</b>
<b>3. REQUIREMENTS AND TEST PROCEDURES .....</b>	<b>13</b>
<b>3.1 AC LINE CONDUCTED EMISSIONS.....</b>	<b>13</b>
3.1.1 Applicable Standard.....	13
3.1.2 EUT Setup.....	14
3.1.3 EMI Test Receiver Setup .....	14
3.1.4 Test Procedure .....	15
3.1.5 Corrected Amplitude & Margin Calculation.....	15
<b>3.2 RADIATION SPURIOUS EMISSIONS.....</b>	<b>16</b>
3.2.1 Applicable Standard.....	16
3.2.2 EUT Setup.....	16
3.2.3 EMI Test Receiver & Spectrum Analyzer Setup .....	17
3.2.4 Test Procedure .....	17
3.2.5 Corrected Amplitude & Margin Calculation.....	17
<b>3.3 MINIMUM 6 DB BANDWIDTH: .....</b>	<b>18</b>
3.3.1 Applicable Standard.....	18
3.3.2 EUT Setup.....	18
3.3.3 Test Procedure .....	18
<b>3.4 99% OCCUPIED BANDWIDTH: .....</b>	<b>19</b>
3.4.1 EUT Setup.....	19
3.4.2 Test Procedure .....	19
<b>3.5 MAXIMUM CONDUCTED OUTPUT POWER: .....</b>	<b>20</b>
3.5.1 Applicable Standard.....	20
3.5.2 EUT Setup.....	20
3.5.3 Test Procedure .....	20
<b>3.6 MAXIMUM POWER SPECTRAL DENSITY: .....</b>	<b>21</b>
3.6.1 Applicable Standard.....	21
3.6.2 EUT Setup.....	21
3.6.3 Test Procedure .....	21
<b>3.7 100 KHZ BANDWIDTH OF FREQUENCY BAND EDGE: .....</b>	<b>22</b>

3.7.1 Applicable Standard.....22  
3.7.2 EUT Setup.....22  
3.7.3 Test Procedure .....22  
**3.8 DUTY CYCLE:.....23**  
3.8.1 EUT Setup.....23  
3.8.2 Test Procedure .....23  
**3.9 ANTENNA REQUIREMENT.....23**  
3.9.1 Applicable Standard.....23  
3.9.2 Judgment.....23  
**4. Test DATA AND RESULTS ..... 24**  
4.1 AC LINE CONDUCTED EMISSIONS.....24  
4.2 RADIATION SPURIOUS EMISSIONS .....27  
4.3 MINIMUM 6 DB EMISSION BANDWIDTH: .....40  
4.4 99% OCCUPIED BANDWIDTH: .....47  
4.5 MAXIMUM CONDUCTED OUTPUT POWER: .....54  
4.6 MAXIMUM POWER SPECTRAL DENSITY: .....56  
4.7 100 kHz BANDWIDTH OF FREQUENCY BAND EDGE: .....70  
4.8 DUTY CYCLE:.....83  
**5. RF EXPOSURE EVALUATION ..... 86**  
5.1 APPLICABLE STANDARD.....86  
5.2 MEASUREMENT RESULT .....87

## DOCUMENT REVISION HISTORY

Revision Number	Report Number	Description of Revision	Date of Revision
1.0	CR230206428-00A	Original Report	2023/4/10

## 1. GENERAL INFORMATION

### 1.1 Product Description for Equipment under Test (EUT)

<b>EUT Name:</b>	AX3000 Dual Band Wi-Fi6 Wireless Hotspot Router
<b>EUT Model:</b>	W30E
<b>Operation Frequency:</b>	2412-2462 MHz(802.11b/g/n ht20/ax hew20) 2422-2452 MHz(802.11n ht40/ax hew40)
<b>Maximum Average Output Power (Conducted):</b>	24.70 dBm
<b>Modulation Type:</b>	802.11b:DSSS-DBPSK, DQPSK, CCK 802.11g/n/ax:OFDM-BPSK, QPSK, 16QAM, 64QAM, 1024QAM
<b>Rated Input Voltage:</b>	DC 12V from Adapter
<b>Serial Number:</b>	21EC
<b>EUT Received Date:</b>	2023/2/16
<b>EUT Received Status:</b>	Good

#### Operation Frequency Detail: For 802.11b/g/n/ ht20/ax hew20:

Channel	Frequency (MHz)	Channel	Frequency (MHz)
1	2412	7	2442
2	2417	8	2447
3	2422	9	2452
4	2427	10	2457
5	2432	11	2462
6	2437	/	/

Per section 15.31(m), the below frequencies were performed the test as below:

Test Channel	Frequency (MHz)
Lowest	2412
Middle	2437
Highest	2462

#### For 802.11n ht40/ax hew40:

Channel	Frequency (MHz)	Channel	Frequency (MHz)
3	2422	7	2442
4	2427	8	2447
5	2432	9	2452
6	2437	/	/

Per section 15.31(m), the below frequencies were performed the test as below:

Test Channel	Frequency (MHz)
Lowest	2422
Middle	2437
Highest	2452

**Antenna Information Detail▲:**

Antenna Chain	Manufacturer	Antenna Type	input impedance (Ohm)	Frequency Range	Antenna Gain
2.4G Chain 0 (TX/RX)	SHENZHEN TENDA TECHNOLOGY CO.,LTD.	Dipole	50	2400-2500MHz	4.84 dBi
2.4G Chain 1 (TX/RX)		Dipole	50	2400-2500MHz	4.84 dBi
2.4G Chain 2 (RX only)		Dipole	50	2400-2500MHz	4.84 dBi

The Method of §15.203 Compliance:

- Antenna must be permanently attached to the unit.  
 Antenna must use a unique type of connector to attach to the EUT.  
 Unit must be professionally installed, and installer shall be responsible for verifying that the correct antenna is employed with the unit.

**Accessory Information:**

Accessory Description	Manufacturer	Model	Parameters
Adapter	SHENZHEN HEWEISHUN NETWORK TECHNOLOGY CO.,LTD	BN074-A18012U	Input: 100-240Vac, 50/60Hz, 0.6A Output: DC12V, 1.5A

## 1.2 Description of Test Configuration

### 1.2.1 EUT Operation Condition:

<b>EUT Operation Mode:</b>	The system was configured for testing in Engineering Mode, which was provided by the manufacturer.
<b>Equipment Modifications:</b>	No
<b>EUT Exercise Software:</b>	AccessMtool

The software was provided by manufacturer. The maximum power was configured as below, that was provided by the manufacturer▲:

Mode	Channel	Frequency (MHz)	Data Rate	Power Level Setting	
				Chain 0	Chain 1
802.11b	Lowest	2412	1Mbps	90	99
	Middle	2437	1Mbps	95	104
	Highest	2462	1Mbps	90	99
802.11g	Lowest	2412	6Mbps	90	82
	Middle	2437	6Mbps	95	100
	Highest	2462	6Mbps	88	84
802.11n ht20	Lowest	2412	MCS0	80	80
	Middle	2437	MCS0	85	85
	Highest	2462	MCS0	80	80
802.11n ht40	Lowest	2422	MCS0	80	80
	Middle	2437	MCS0	85	85
	Highest	2452	MCS0	80	80
802.11ax hew20	Lowest	2412	MCS0	76	76
	Middle	2437	MCS0	85	85
	Highest	2462	MCS0	80	80
802.11ax hew40	Lowest	2422	MCS0	80	80
	Middle	2437	MCS0	85	85
	Highest	2452	MCS0	78	78

Note:

1. The above are the worst-case data rates, which are determined for each mode based upon investigations by measuring the average power and PSD across all data rates, bandwidths, and modulations.
2. The device supports SISO in all modes, and MIMO 2T3R in 802.11n/ax modes, per pretest, 2T3R mode was the worst mode and reported for 802.11n/ax modes.
3. The system supports Beamforming and Non-beamforming modes at 802.11n/ax modes. The two modes have same output power, and the Beamforming gain is 3 dBi▲, which are declared by manufacturer. Therefore, the all RF conducted test were performed at Non-beamforming mode only.

### 1.2.2 Support Equipment List and Details

Manufacturer	Description	Model	Serial Number
Lenovo	Laptop	T460S	60PDTEK8
Unknown	RJ 45 Load	Unknown	RJ 45 Load-1
Kingston	USB Flash Disk	16G	U-16G



### 1.2.3 Support Cable List and Details

Cable Description	Shielding Type	Ferrite Core	Length (m)	From Port	To
RJ45 Cable*3	Yes	No	10	EUT	Load
DC Cable	No	No	1.2	Adapter	EUT
RJ45 Cable	Yes	No	10	EUT	Laptop

### 1.2.4 Block Diagram of Test Setup

AC line conducted emissions:

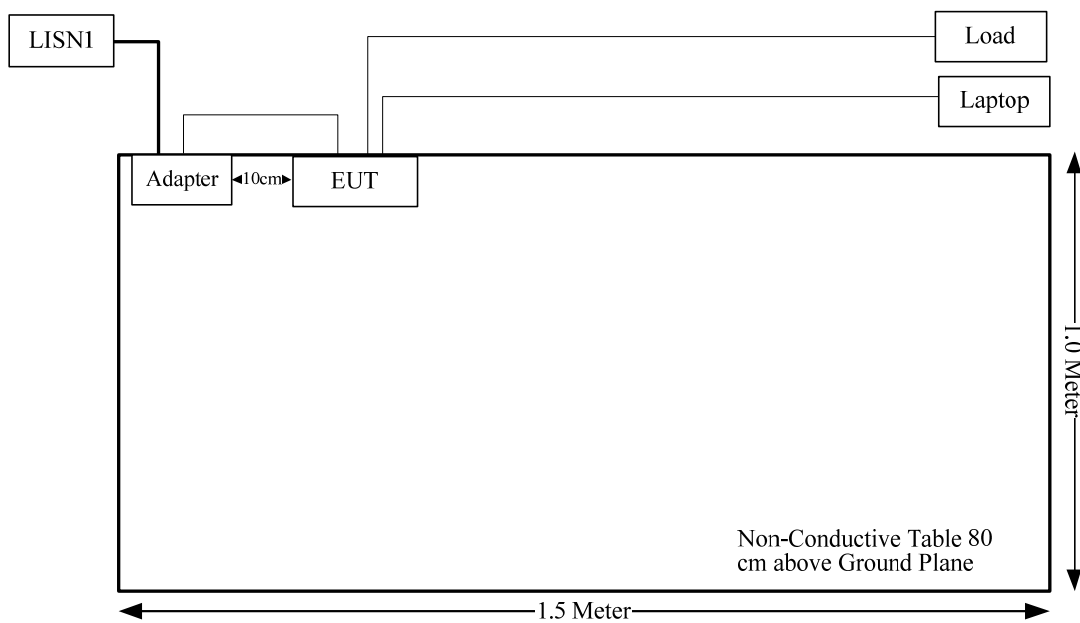

Spurious Emissions:

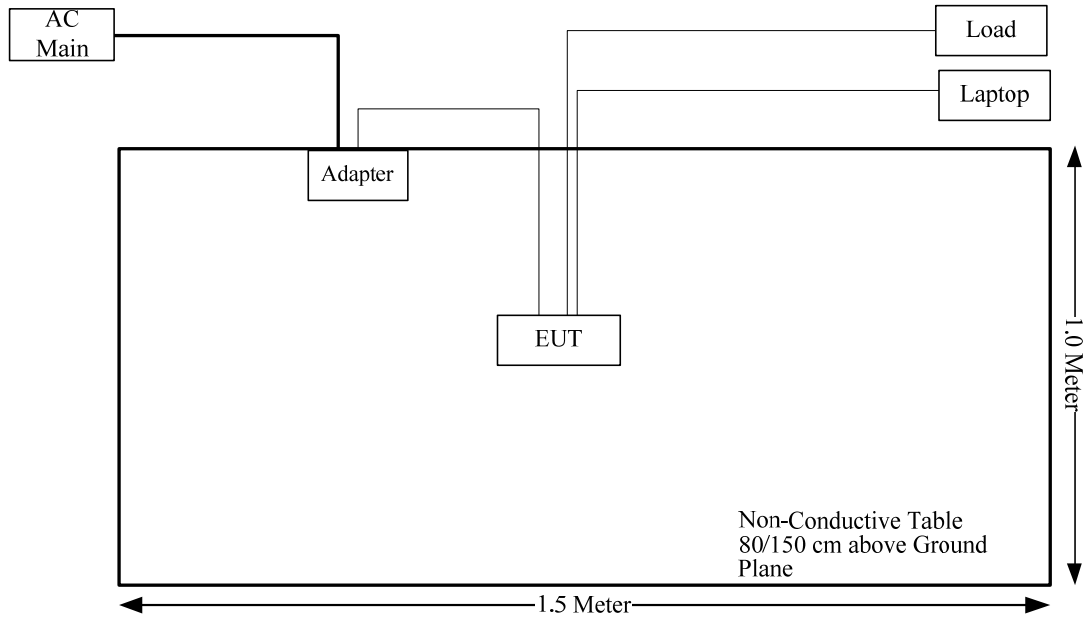

### 1.3 Measurement Uncertainty

Otherwise required by the applicant or Product Regulations, Decision Rule in this report did not consider the uncertainty. The extended uncertainty given in this report is obtained by combining the standard uncertainty times the coverage factor K with the 95% confidence interval.

Parameter	Measurement Uncertainty
Occupied Channel Bandwidth	±5 %
RF output power, conducted	±0.61dB
Power Spectral Density, conducted	±0.61 dB
Unwanted Emissions, radiated	30M~200MHz: 4.15 dB,200M~1GHz: 5.61 dB,1G~6GHz: 5.14 dB, 6G~18GHz: 5.93 dB,18G~26.5G:5.47 dB,26.5G~40G:5.63 dB
Unwanted Emissions, conducted	±1.26 dB
Temperature	±1°C
Humidity	±5%
DC and low frequency voltages	±0.4%
Duty Cycle	1%
AC Power Lines Conducted Emission	2.8 dB (150 kHz to 30 MHz)

## 2. SUMMARY OF TEST RESULTS

Standard(s) Section	Test Items	Result
§15.207(a)	AC line conducted emissions	Compliant
§15.205, §15.209, §15.247(d)	Radiated Spurious Emissions	Compliant
§15.247 (a)(2)	Minimum 6 dB Bandwidth	Compliant
§15.247(b)(3)	Maximum Conducted Output Power	Compliant
§15.247(e)	Power Spectral Density	Compliant
§15.247(d)	100 kHz Bandwidth of Frequency Band Edge	Compliant
§15.203	Antenna Requirement	Compliant
§15.247 (i) & §1.1307 & §2.1091	RF Exposure Evaluation	Compliant

### 3. REQUIREMENTS AND TEST PROCEDURES

#### 3.1 AC Line Conducted Emissions

##### 3.1.1 Applicable Standard

FCC§15.207(a).

(a) Except as shown in paragraphs (b) and (c) of this section, for an intentional radiator that is designed to be connected to the public utility (AC) power line, the radio frequency voltage that is conducted back onto the AC power line on any frequency or frequencies, within the band 150 kHz to 30 MHz, shall not exceed the limits in the following table, as measured using a 50  $\mu$ H/50 ohms line impedance stabilization network (LISN). Compliance with the provisions of this paragraph shall be based on the measurement of the radio frequency voltage between each power line and ground at the power terminal. The lower limit applies at the boundary between the frequency ranges.

Frequency of emission (MHz)	Conducted limit (dB $\mu$ V)	
	Quasi-peak	Average
0.15-0.5	66 to 56*	56 to 46*
0.5-5	56	46
5-30	60	50

\*Decreases with the logarithm of the frequency.

(b) The limit shown in paragraph (a) of this section shall not apply to carrier current systems operating as intentional radiators on frequencies below 30 MHz. In lieu thereof, these carrier current systems shall be subject to the following standards:

(1) For carrier current system containing their fundamental emission within the frequency band 535-1705 kHz and intended to be received using a standard AM broadcast receiver: no limit on conducted emissions.

(2) For all other carrier current systems: 1000  $\mu$ V within the frequency band 535-1705 kHz, as measured using a 50  $\mu$ H/50 ohms LISN.

(3) Carrier current systems operating below 30 MHz are also subject to the radiated emission limits in §15.205, §15.209, §15.221, §15.223, or §15.227, as appropriate.

(c) Measurements to demonstrate compliance with the conducted limits are not required for devices which only employ battery power for operation and which do not operate from the AC power lines or contain provisions for operation while connected to the AC power lines. Devices that include, or make provisions for, the use of battery chargers which permit operating while charging, AC adapters or battery eliminators or that connect to the AC power lines indirectly, obtaining their power through another device which is connected to the AC power lines, shall be tested to demonstrate compliance with the conducted limits.

### 3.1.2 EUT Setup



- Note: 1. Support units were connected to second LISN.  
 2. Both of LISNs (AMN) 80 cm from EUT and at the least 80 cm from other units and other metal planes support units.

The setup of EUT is according with per ANSI C63.10-2013 measurement procedure. The specification used was with the FCC Part 15.207 limits.

The spacing between the peripherals was 10 cm.

The adapter or EUT was connected to the main LISN with a 120 V/60 Hz AC power source.

### 3.1.3 EMI Test Receiver Setup

The EMI test receiver was set to investigate the spectrum from 150 kHz to 30 MHz.

During the conducted emission test, the EMI test receiver was set with the following configurations:

Frequency Range	IF B/W
150 kHz – 30 MHz	9 kHz

### 3.1.4 Test Procedure

The frequency and amplitude of the six highest ac power-line conducted emissions relative to the limit, measured over all the current-carrying conductors of the EUT power cords, and the operating frequency or frequency to which the EUT is tuned (if appropriate), should be reported, unless such emissions are more than 20 dB below the limit. AC power-line conducted emissions measurements are to be separately carried out only on each of the phase (“hot”) line(s) and (if used) on the neutral line(s), but not on the ground [protective earth] line(s). If less than six emission frequencies are within 20 dB of the limit, then the noise level of the measuring instrument at representative frequencies should be reported. The specific conductor of the power-line cord for each of the reported emissions should be identified. Measure the six highest emissions with respect to the limit on each current-carrying conductor of each power cord associated with the EUT (but not the power cords of associated or peripheral equipment that are part of the test configuration). Then, report the six highest emissions with respect to the limit from among all the measurements identifying the frequency and specific current-carrying conductor identified with the emission. The six highest emissions should be reported for each of the current-carrying conductors, or the six highest emissions may be reported over all the current-carrying conductors.

### 3.1.5 Corrected Amplitude & Margin Calculation

The basic equation is as follows:

Result = Reading + Factor

Factor = attenuation caused by cable loss + voltage division factor of AMN

The “**Margin**” column of the following data tables indicates the degree of compliance within the applicable limit. The equation for margin calculation is as follows:

Margin = Limit – Result

## 3.2 Radiation Spurious Emissions

### 3.2.1 Applicable Standard

FCC §15.247 (d)

In any 100 kHz bandwidth outside the frequency band in which the spread spectrum or digitally modulated intentional radiator is operating, the radio frequency power that is produced by the intentional radiator shall be at least 20 dB below that in the 100 kHz bandwidth within the band that contains the highest level of the desired power, based on either an RF conducted or a radiated measurement, provided the transmitter demonstrates compliance with the peak conducted power limits. If the transmitter complies with the conducted power limits based on the use of RMS averaging over a time interval, as permitted under paragraph (b)(3) of this section, the attenuation required under this paragraph shall be 30 dB instead of 20 dB. Attenuation below the general limits specified in §15.209(a) is not required. In addition, radiated emissions which fall in the restricted bands, as defined in §15.205(a), must also comply with the radiated emission limits specified in §15.209(a) (see §15.205(c)).

### 3.2.2 EUT Setup

Below 1GHz:

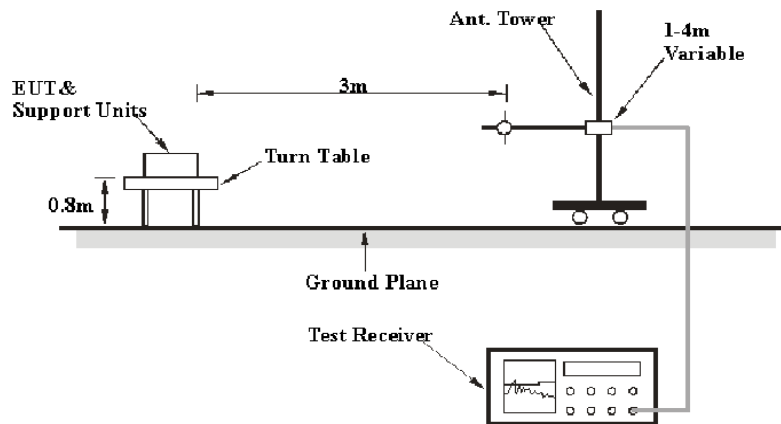

Above 1GHz:

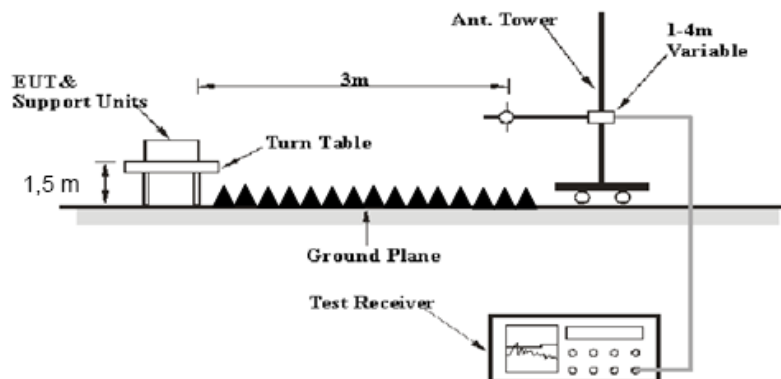

The radiated emissions were performed in the 3 meters distance, using the setup accordance with the ANSI C63.10-2013. The specification used was the FCC 15.209, and FCC 15.247 limits.



The external I/O cables were draped along the test table and formed a bundle 30 to 40 cm long in the middle.

The spacing between the peripherals was 10 cm.

### 3.2.3 EMI Test Receiver & Spectrum Analyzer Setup

The system was investigated from 30 MHz to 25 GHz.

During the radiated emission test, the EMI test receiver & Spectrum Analyzer Setup were set with the following configurations:

30MHz-1000MHz:

Measurement	RBW	Video B/W	IF B/W
QP	120 kHz	300 kHz	120kHz

1GHz- 25GHz:

Measurement	Duty cycle	RBW	Video B/W
PK	Any	1MHz	3 MHz
AV	>98%	1MHz	10 Hz
	<98%	1MHz	1/T

Note: T is minimum transmission duration

If the maximized peak measured value complies with under the QP/Average limit more than 6dB, then it is unnecessary to perform an QP/Average measurement.

### 3.2.4 Test Procedure

Maximizing procedure was performed on the highest emissions to ensure that the EUT complied with all installation combinations.

Data was recorded in Quasi-peak detection mode for frequency range of 30 MHz-1 GHz, peak and Average detection modes for frequencies above 1 GHz.

### 3.2.5 Corrected Amplitude & Margin Calculation

The basic equation is as follows:

Result = Reading + Factor

Factor = Antenna Factor + Cable Loss- Amplifier Gain

The “**Margin**” column of the following data tables indicates the degree of compliance within the applicable limit. The equation for margin calculation is as follows:

Margin = Limit – Result

### 3.3 Minimum 6 dB Bandwidth:

#### 3.3.1 Applicable Standard

FCC §15.247 (a)(2)

Systems using digital modulation techniques may operate in the 902-928 MHz, 2400-2483.5 MHz, and 5725-5850 MHz bands. The minimum 6 dB bandwidth shall be at least 500 kHz.

#### 3.3.2 EUT Setup

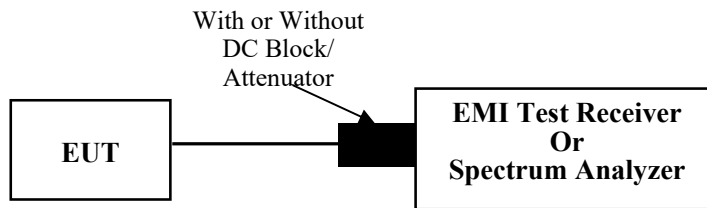

#### 3.3.3 Test Procedure

According to ANSI C63.10-2013 Section 11.8

- a) Set RBW = 100 kHz.
- b) Set the video bandwidth (VBW)  $\geq 3 \times$  RBW.
- c) Detector = Peak.
- d) Trace mode = max hold.
- e) Sweep = auto couple.
- f) Allow the trace to stabilize.
- g) Measure the maximum width of the emission that is constrained by the frequencies associated with the two outermost amplitude points (upper and lower frequencies) that are attenuated by 6 dB relative to the maximum level measured in the fundamental emission.

### 3.4 99% Occupied Bandwidth:

#### 3.4.1 EUT Setup

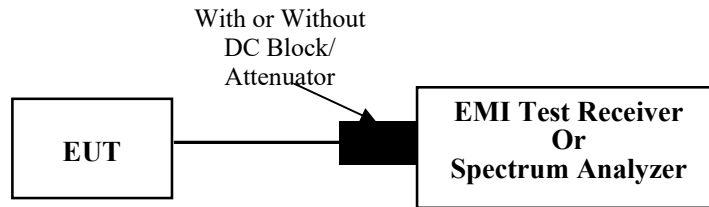

#### 3.4.2 Test Procedure

According to ANSI C63.10-2013 Section 6.9.3

The occupied bandwidth is the frequency bandwidth such that, below its lower and above its upper frequency limits, the mean powers are each equal to 0.5% of the total mean power of the given emission. The following procedure shall be used for measuring 99% power bandwidth:

- a) The instrument center frequency is set to the nominal EUT channel center frequency. The frequency span for the spectrum analyzer shall be between 1.5 times and 5.0 times the OBW.
- b) The nominal IF filter bandwidth (3 dB RBW) shall be in the range of 1% to 5% of the OBW, and VBW shall be approximately three times the RBW, unless otherwise specified by the applicable requirement.
- c) Set the reference level of the instrument as required, keeping the signal from exceeding the maximum input mixer level for linear operation. In general, the peak of the spectral envelope shall be more than  $[10 \log (OBW/RBW)]$  below the reference level. Specific guidance is given in 4.1.5.2.
- d) Step a) through step c) might require iteration to adjust within the specified range.
- e) Video averaging is not permitted. Where practical, a sample detection and single sweep mode shall be used. Otherwise, peak detection and max hold mode (until the trace stabilizes) shall be used.
- f) Use the 99% power bandwidth function of the instrument (if available) and report the measured bandwidth.
- g) If the instrument does not have a 99% power bandwidth function, then the trace data points are recovered and directly summed in linear power terms. The recovered amplitude data points, beginning at the lowest frequency, are placed in a running sum until 0.5% of the total is reached; that frequency is recorded as the lower frequency. The process is repeated until 99.5% of the total is reached; that frequency is recorded as the upper frequency. The 99% power bandwidth is the difference between these two frequencies.
- h) The occupied bandwidth shall be reported by providing plot(s) of the measuring instrument display; the plot axes and the scale units per division shall be clearly labeled. Tabular data may be reported in addition to the plot(s).

### 3.5 Maximum Conducted Output Power:

#### 3.5.1 Applicable Standard

FCC §15.247 (b)(3)

For systems using digital modulation in the 902-928 MHz, 2400-2483.5 MHz, and 5725-5850 MHz bands: 1 Watt. As an alternative to a peak power measurement, compliance with the one Watt limit can be based on a measurement of the maximum conducted output power. Maximum Conducted Output Power is defined as the total transmit power delivered to all antennas and antenna elements averaged across all symbols in the signaling alphabet when the transmitter is operating at its maximum power control level. Power must be summed across all antennas and antenna elements. The average must not include any time intervals during which the transmitter is off or is transmitting at a reduced power level. If multiple modes of operation are possible (e.g., alternative modulation methods), the maximum conducted output power is the highest total transmit power occurring in any mode.

#### 3.5.2 EUT Setup

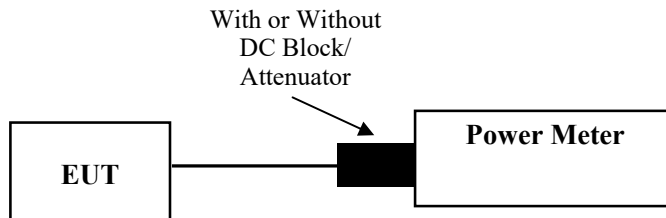

#### 3.5.3 Test Procedure

According to ANSI C63.10-2013 Section 11.9.2.3.2

Method AVGPM-G is a measurement using a gated RF average power meter.

Alternatively, measurements may be performed using a wideband gated RF power meter provided that the gate parameters are adjusted such that the power is measured only when the EUT is transmitting at its maximum power control level. Because the measurement is made only during the ON time of the transmitter, no duty cycle correction factor is required.

### 3.6 Maximum Power Spectral Density:

#### 3.6.1 Applicable Standard

FCC §15.247 (e)

For digitally modulated systems, the power spectral density conducted from the intentional radiator to the antenna shall not be greater than 8 dBm in any 3 kHz band during any time interval of continuous transmission. This power spectral density shall be determined in accordance with the provisions of paragraph (b) of this section. The same method of determining the conducted output power shall be used to determine the power spectral density.

#### 3.6.2 EUT Setup

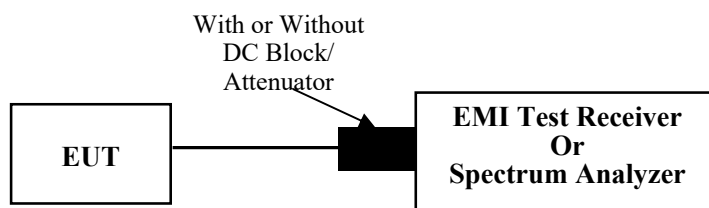

#### 3.6.3 Test Procedure

**Duty cycle  $\geq 98\%$**

According to ANSI C63.10-2013 Section 11.10.3

**Duty cycle  $< 98\%$ , duty cycle variations are less than  $\pm 2\%$**

According to ANSI C63.10-2013 Section 11.10.5

**Duty cycle  $< 98\%$ , duty cycle variations exceed  $\pm 2\%$**

According to ANSI C63.10-2013 Section 11.10.7

### 3.7 100 kHz Bandwidth of Frequency Band Edge:

#### 3.7.1 Applicable Standard

FCC §15.247 (d);

In any 100 kHz bandwidth outside the frequency band in which the spread spectrum or digitally modulated intentional radiator is operating, the radio frequency power that is produced by the intentional radiator shall be at least 20 dB below that in the 100 kHz bandwidth within the band that contains the highest level of the desired power, based on either an RF conducted or a radiated measurement, provided the transmitter demonstrates compliance with the peak conducted power limits. If the transmitter complies with the conducted power limits based on the use of RMS averaging over a time interval, as permitted under paragraph (b)(3) of this section, the attenuation required under this paragraph shall be 30 dB instead of 20 dB. Attenuation below the general limits specified in §15.209(a) is not required. In addition, radiated emissions which fall in the restricted bands, as defined in §15.205(a), must also comply with the radiated emission limits specified in §15.209(a) (see §15.205(c)).

#### 3.7.2 EUT Setup

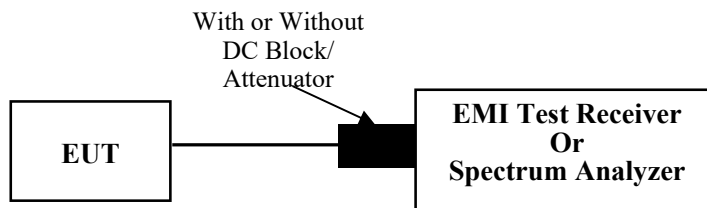

#### 3.7.3 Test Procedure

According to ANSI C63.10-2013 Section 11.11

- a) Set the center frequency and span to encompass frequency range to be measured.
- b) Set the RBW = 100 kHz.
- c) Set the VBW  $\geq [3 \times \text{RBW}]$ .
- d) Detector = peak.
- e) Sweep time = auto couple.
- f) Trace mode = max hold.
- g) Allow trace to fully stabilize.
- h) Use the peak marker function to determine the maximum amplitude level.

Ensure that the amplitude of all unwanted emissions outside of the authorized frequency band (excluding restricted frequency bands) is attenuated by at least the minimum requirements specified in 11.11. Report the three highest emissions relative to the limit.

### 3.8 Duty Cycle:

#### 3.8.1 EUT Setup

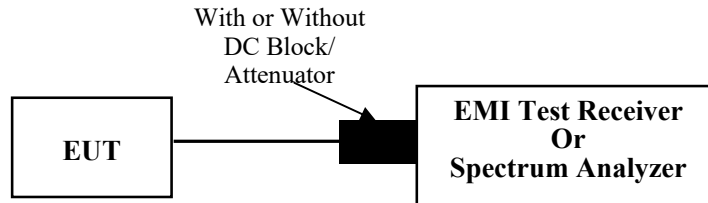

#### 3.8.2 Test Procedure

According to ANSI C63.10-2013 Section 11.6

The zero-span mode on a spectrum analyzer or EMI receiver if the response time and spacing between bins on the sweep are sufficient to permit accurate measurements of the ON and OFF times of the transmitted signal:

- 1) Set the center frequency of the instrument to the center frequency of the transmission.
- 2) Set  $RBW \geq OBW$  if possible; otherwise, set RBW to the largest available value.
- 3) Set  $VBW \geq RBW$ . Set detector = peak or average.
- 4) The zero-span measurement method shall not be used unless both RBW and VBW are  $> 50/T$  and the number of sweep points across duration T exceeds 100. (For example, if VBW and/or RBW are limited to 3 MHz, then the zero-span method of measuring the duty cycle shall not be used if  $T \leq 16.7 \mu s$ .)

### 3.9 Antenna Requirement

#### 3.9.1 Applicable Standard

FCC §15.203

An intentional radiator shall be designed to ensure that no antenna other than that furnished by the responsible party shall be used with the device. The use of a permanently attached antenna or of an antenna that uses a unique coupling to the intentional radiator shall be considered sufficient to comply with the provisions of this section. The manufacturer may design the unit so that a broken antenna can be replaced by the user, but the use of a standard antenna jack or electrical connector is prohibited. This requirement does not apply to carrier current devices or to devices operated under the provisions of §§15.211, 15.213, 15.217, 15.219, 15.221, or §15.236. Further, this requirement does not apply to intentional radiators that must be professionally installed, such as perimeter protection systems and some field disturbance sensors, or to other intentional radiators which, in accordance with §15.31(d), must be measured at the installation site. However, the installer shall be responsible for ensuring that the proper antenna is employed so that the limits in this part are not exceeded.

#### 3.9.2 Judgment

**Compliant.** Please refer to the Antenna Information detail in Section 1.

## 4. Test DATA AND RESULTS

### 4.1 AC Line Conducted Emissions

Serial Number:	21EC	Test Date:	2023/02/23
Test Site:	CE	Test Mode:	Transmitting (802.11b mode chain 0 middle channel was the worst)
Tester:	Bob Yang	Test Result:	Pass

#### Environmental Conditions:

Temperature: (°C)	22.4	Relative Humidity: (%)	49	ATM Pressure: (kPa)	101.8
----------------------	------	------------------------------	----	------------------------	-------

#### Test Equipment List and Details:

Manufacturer	Description	Model	Serial Number	Calibration Date	Calibration Due Date
R&S	LISN	ENV216	101134	2022/04/01	2023/03/31
R&S	EMI Test Receiver	ESR3	102726	2022/07/15	2023/07/14
MICRO-COAX	Coaxial Cable	UTIFLEX	C-0200-01	2022/08/07	2023/08/06
Audix	Test Software	E3	190306 (V9)	N/A	N/A

\* Statement of Traceability: China Certification ICT Co., Ltd (Dongguan) attests that all calibrations have been performed, traceable to National Primary Standards and International System of Units (SI).

#### Test Data:



Test Mode: Transmitting  
 Port: Line  
 Note:

Date: 2023-02-23

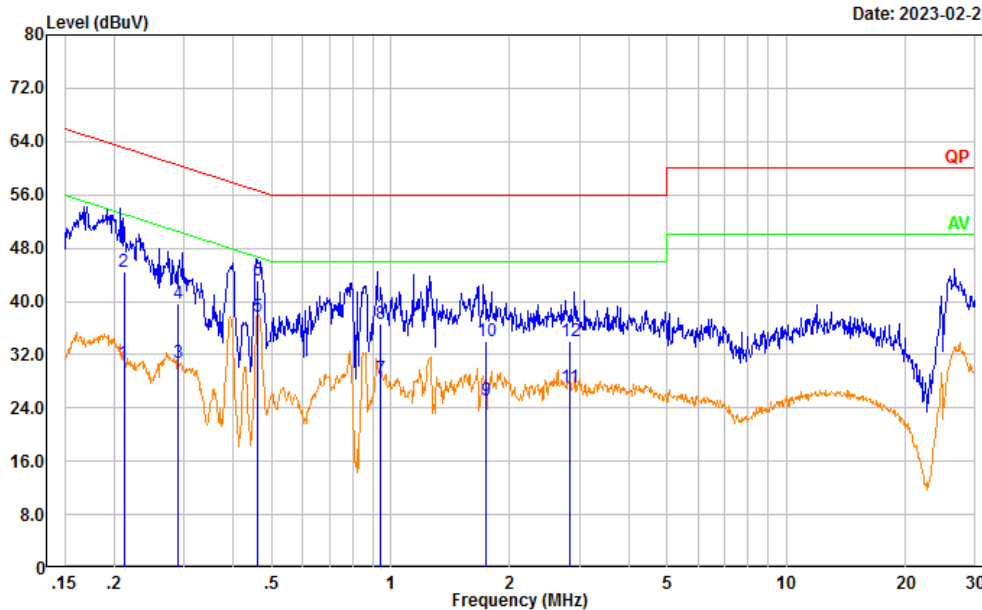

No.	Frequency (MHz)	Reading (dBμV)	Factor (dB)	Result (dBμV)	Limit (dBμV)	Margin (dB)	Detector
1	0.212	21.22	9.61	30.83	53.14	22.31	Average
2	0.212	34.85	9.61	44.46	63.14	18.68	QP
3	0.290	21.12	9.61	30.73	50.53	19.80	Average
4	0.290	30.02	9.61	39.63	60.53	20.90	QP
5	0.459	28.09	9.61	37.70	46.71	9.01	Average
6	0.459	33.43	9.61	43.04	56.71	13.67	QP
7	0.944	18.81	9.62	28.43	46.00	17.57	Average
8	0.944	27.09	9.62	36.71	56.00	19.29	QP
9	1.744	15.42	9.63	25.05	46.00	20.95	Average
10	1.744	24.50	9.63	34.13	56.00	21.87	QP
11	2.827	17.53	9.65	27.18	46.00	18.82	Average
12	2.827	24.37	9.65	34.02	56.00	21.98	QP

Test Mode: Transmitting  
 Port: neutral  
 Note:

Date: 2023-02-23

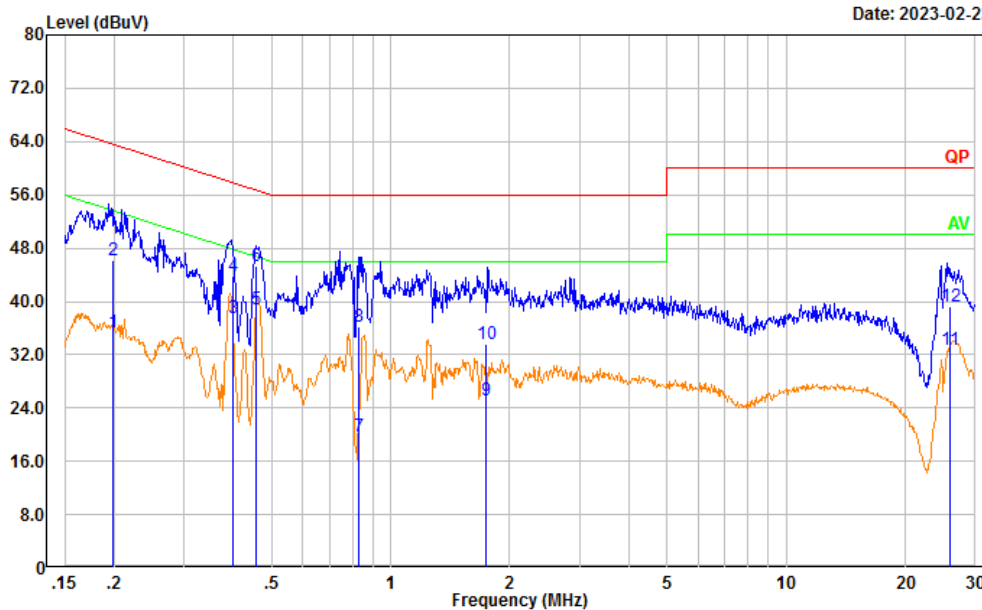

No.	Frequency (MHz)	Reading (dBμV)	Factor (dB)	Result (dBμV)	Limit (dBμV)	Margin (dB)	Detector
1	0.198	25.79	9.61	35.40	53.69	18.29	Average
2	0.198	36.59	9.61	46.20	63.69	17.49	QP
3	0.398	27.86	9.61	37.47	47.90	10.43	Average
4	0.398	34.27	9.61	43.88	57.90	14.02	QP
5	0.456	29.21	9.61	38.82	46.76	7.94	Average
6	0.456	35.74	9.61	45.35	56.76	11.41	QP
7	0.832	10.02	9.62	19.64	46.00	26.36	Average
8	0.832	26.64	9.62	36.26	56.00	19.74	QP
9	1.746	15.55	9.63	25.18	46.00	20.82	Average
10	1.746	24.05	9.63	33.68	56.00	22.32	QP
11	25.881	22.91	9.78	32.69	50.00	17.31	Average
12	25.881	29.51	9.78	39.29	60.00	20.71	QP

## 4.2 Radiation Spurious Emissions

Serial Number:	21EC	Test Date:	2023/02/23 ~2023/02/26
Test Site:	966-1/966-2	Test Mode:	Transmitting
Tester:	Vic Du, Mack Huang	Test Result:	Pass

### Environmental Conditions:

Temperature: (°C)	22.2~24.4	Relative Humidity: (%)	39~42	ATM Pressure: (kPa)	101.8~102.5
----------------------	-----------	------------------------------	-------	------------------------	-------------

### Test Equipment List and Details:

Manufacturer	Description	Model	Serial Number	Calibration Date	Calibration Due Date
Sunol Sciences	Antenna	JB6	A082520-5	2020/10/19	2023/10/18
R&S	EMI Test Receiver	ESR3	102724	2022/07/15	2023/07/14
TIMES MICROWAVE	Coaxial Cable	LMR-600-UltraFlex	C-0470-02	2022/07/17	2023/07/16
TIMES MICROWAVE	Coaxial Cable	LMR-600-UltraFlex	C-0780-01	2022/07/17	2023/07/16
Sonoma	Amplifier	310N	186165	2022/07/17	2023/07/16
Audix	Test Software	E3	201021 (V9)	N/A	N/A
ETS-Lindgren	Horn Antenna	3115	9912-5985	2020/10/13	2023/10/12
R&S	Spectrum Analyzer	FSV40	101591	2022/07/15	2023/07/14
MICRO-COAX	Coaxial Cable	UFA210A-1-1200-70U300	217423-008	2022/08/07	2023/08/06
MICRO-COAX	Coaxial Cable	UFA210A-1-2362-300300	235780-001	2022/08/07	2023/08/06
Mini	Pre-amplifier	ZVA-183-S+	5969001149	2022/11/09	2023/11/08
PASTERNAK	Horn Antenna	PE9852/2F-20	112002	2021/02/05	2024/02/04
AH	Preamplifier	PAM-1840VH	190	2022/11/09	2023/11/08
MICRO-COAX	Coaxial Cable	UFB142A-1-2362-200200	235772-001	2022/08/07	2023/08/06
E-Microwave	Band Rejection Filter	2400-2483.5MHz	OE01902424	2022/08/07	2023/08/06

\* Statement of Traceability: China Certification ICT Co., Ltd (Dongguan) attests that all calibrations have been performed, traceable to National Primary Standards and International System of Units (SI).

### Test Data:

Please refer to the below table and plots.

Note: The device can be mounted in multiple orientations, test was performed with X,Y, Z Axis according to C63.10 Figure 8, the worst orientation was photographed and it's data was recorded.

1) 30MHz-1GHz(802.11b Chain 0 Low channel was the worst)

Test Mode: Transmitting  
 Polarization: vertical  
 Note:

Date: 2023-02-23

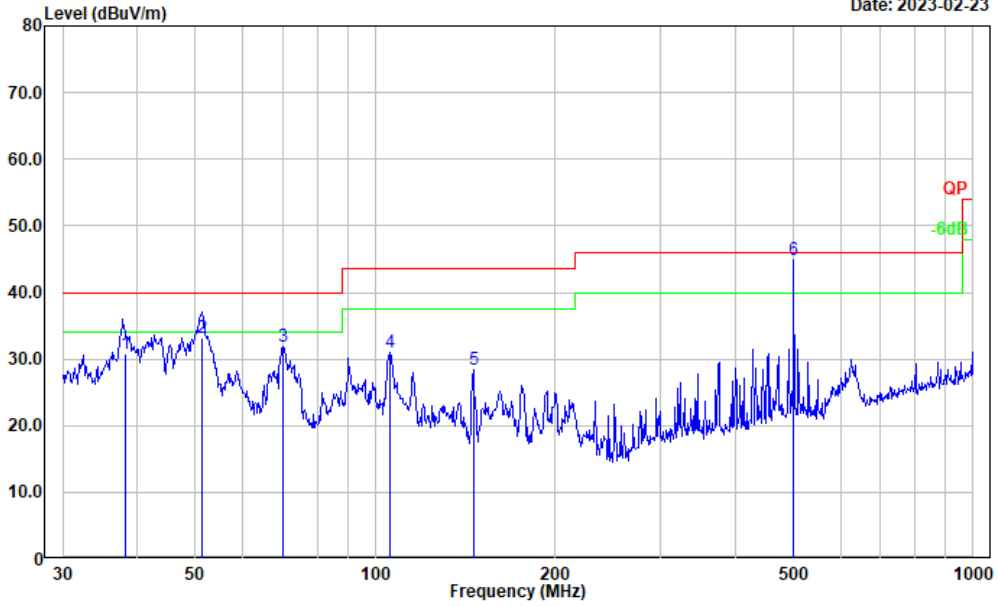

No.	Frequency (MHz)	Reading (dBμV)	Factor (dB/m)	Result (dBμV/m)	Limit (dBμV/m)	Margin (dB)	Detector
1	38.148	40.73	-9.85	30.88	40.00	9.12	QP
2	51.186	50.40	-17.22	33.18	40.00	6.82	QP
3	70.090	48.29	-16.47	31.82	40.00	8.18	Peak
4	105.642	44.33	-13.23	31.10	43.50	12.40	Peak
5	145.861	40.44	-11.97	28.47	43.50	15.03	Peak
6	499.997	50.90	-5.99	44.91	46.00	1.09	QP

Test Mode: Transmitting  
 Polarization: horizontal  
 Note:

Date: 2023-02-23

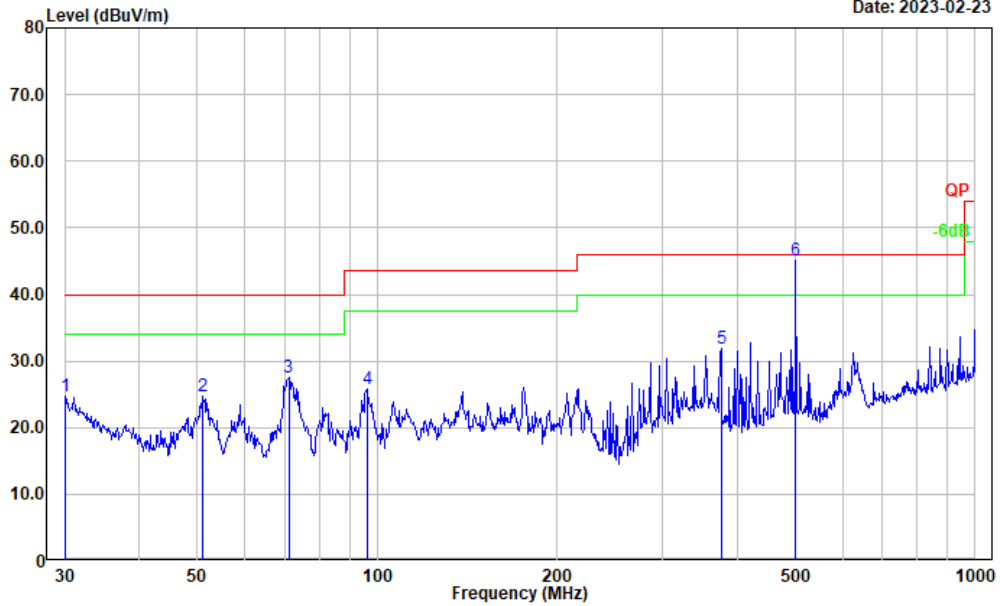

No.	Frequency (MHz)	Reading (dBμV)	Factor (dB/m)	Result (dBμV/m)	Limit (dBμV/m)	Margin (dB)	Detector
1	30.000	28.28	-3.60	24.68	40.00	15.32	Peak
2	51.121	41.94	-17.21	24.73	40.00	15.27	Peak
3	71.080	44.04	-16.59	27.45	40.00	12.55	Peak
4	96.099	41.14	-15.31	25.83	43.50	17.67	Peak
5	375.939	41.14	-9.29	31.85	46.00	14.15	Peak
6	499.997	51.09	-5.99	45.10	46.00	0.90	QP

2) 1-25GHz:  
802.11b Mode, Chain 0:

Frequency (MHz)	Receiver		Polar (H/V)	Factor (dB/m)	Result (dB $\mu$ V/m)	Limit (dB $\mu$ V/m)	Margin (dB)
	Reading (dB $\mu$ V)	Detector					
Low Channel: 2412 MHz							
2412.000	74.06	PK	H	31.53	105.59	N/A	N/A
2412.000	71.38	AV	H	31.53	102.91	N/A	N/A
2412.000	80.97	PK	V	31.53	112.50	N/A	N/A
2412.000	77.67	AV	V	31.53	109.20	N/A	N/A
2390.000	28.66	PK	V	31.46	60.12	74.00	13.88
2390.000	16.10	AV	V	31.46	47.56	54.00	6.44
4824.000	44.68	PK	V	10.94	55.62	74.00	18.38
4824.000	40.51	AV	V	10.94	51.45	54.00	2.55
7236.000	36.33	PK	V	14.44	50.77	74.00	23.23
7236.000	24.17	AV	V	14.44	38.61	54.00	15.39
Middle Channel: 2437 MHz							
2437.000	75.41	PK	H	31.60	107.01	N/A	N/A
2437.000	72.12	AV	H	31.60	103.72	N/A	N/A
2437.000	81.22	PK	V	31.60	112.82	N/A	N/A
2437.000	78.43	AV	V	31.60	110.03	N/A	N/A
4874.000	43.01	PK	V	11.05	54.06	74.00	19.94
4874.000	39.27	AV	V	11.05	50.32	54.00	3.68
7311.000	36.40	PK	V	14.80	51.20	74.00	22.80
7311.000	24.20	AV	V	14.80	39.00	54.00	15.00
High Channel: 2462MHz							
2462.000	73.69	PK	H	31.63	105.32	N/A	N/A
2462.000	70.30	AV	H	31.63	101.93	N/A	N/A
2462.000	80.37	PK	V	31.63	112.00	N/A	N/A
2462.000	77.20	AV	V	31.63	108.83	N/A	N/A
2483.500	31.16	PK	V	31.64	62.80	74.00	11.20
2483.500	19.00	AV	V	31.64	50.64	54.00	3.36
4924.000	40.63	PK	V	11.18	51.81	74.00	22.19
4924.000	36.12	AV	V	11.18	47.30	54.00	6.70
7386.000	36.61	PK	V	14.89	51.50	74.00	22.50
7386.000	24.31	AV	V	14.89	39.20	54.00	14.80

**802.11b Mode, Chain 1:**

Frequency (MHz)	Receiver		Polar (H/V)	Factor (dB/m)	Result (dB $\mu$ V/m)	Limit (dB $\mu$ V/m)	Margin (dB)
	Reading (dB $\mu$ V)	Detector					
Low Channel: 2412 MHz							
2412.000	77.82	PK	H	31.53	109.35	N/A	N/A
2412.000	73.13	AV	H	31.53	104.66	N/A	N/A
2412.000	82.33	PK	V	31.53	113.86	N/A	N/A
2412.000	78.90	AV	V	31.53	110.43	N/A	N/A
2390.000	29.25	PK	V	31.46	60.71	74.00	13.29
2390.000	15.93	AV	V	31.46	47.39	54.00	6.61
4824.000	45.77	PK	V	10.94	56.71	74.00	17.29
4824.000	39.26	AV	V	10.94	50.20	54.00	3.80
7236.000	43.86	PK	V	14.44	58.30	74.00	15.70
7236.000	37.92	AV	V	14.44	52.36	54.00	1.64
Middle Channel: 2437 MHz							
2437.000	78.25	PK	H	31.60	109.85	N/A	N/A
2437.000	74.51	AV	H	31.60	106.11	N/A	N/A
2437.000	84.26	PK	V	31.60	115.86	N/A	N/A
2437.000	80.45	AV	V	31.60	112.05	N/A	N/A
4874.000	45.09	PK	V	11.05	56.14	74.00	17.86
4874.000	39.41	AV	V	11.05	50.46	54.00	3.54
7311.000	43.49	PK	V	14.80	58.29	74.00	15.71
7311.000	37.45	AV	V	14.80	52.25	54.00	1.75
High Channel: 2462MHz							
2462.000	74.59	PK	H	31.63	106.22	N/A	N/A
2462.000	70.37	AV	H	31.63	102.00	N/A	N/A
2462.000	82.31	PK	V	31.63	113.94	N/A	N/A
2462.000	78.64	AV	V	31.63	110.27	N/A	N/A
2483.500	30.11	PK	V	31.64	61.75	74.00	12.25
2483.500	17.06	AV	V	31.64	48.70	54.00	5.30
4924.000	43.88	PK	V	11.18	55.06	74.00	18.94
4924.000	37.78	AV	V	11.18	48.96	54.00	5.04
7386.000	43.58	PK	V	14.89	58.47	74.00	15.53
7386.000	37.64	AV	V	14.89	52.53	54.00	1.47

**802.11g Mode Chain 0:**

Frequency (MHz)	Receiver		Polar (H/V)	Factor (dB/m)	Result (dB $\mu$ V/m)	Limit (dB $\mu$ V/m)	Margin (dB)
	Reading (dB $\mu$ V)	Detector					
Low Channel: 2412 MHz							
2412.000	75.59	PK	H	31.53	107.12	N/A	N/A
2412.000	65.32	AV	H	31.53	96.85	N/A	N/A
2412.000	80.73	PK	V	31.53	112.26	N/A	N/A
2412.000	70.62	AV	V	31.53	102.15	N/A	N/A
2390.000	41.49	PK	V	31.46	72.95	74.00	1.05
2390.000	19.34	AV	V	31.46	50.80	54.00	3.20
4824.000	41.56	PK	V	10.94	52.50	74.00	21.50
4824.000	29.28	AV	V	10.94	40.22	54.00	13.78
7236.000	36.17	PK	V	14.44	50.61	74.00	23.39
7236.000	24.09	AV	V	14.44	38.53	54.00	15.47
Middle Channel: 2437 MHz							
2437.000	75.63	PK	H	31.60	107.23	N/A	N/A
2437.000	65.27	AV	H	31.60	96.87	N/A	N/A
2437.000	82.14	PK	V	31.60	113.74	N/A	N/A
2437.000	72.36	AV	V	31.60	103.96	N/A	N/A
4874.000	40.38	PK	V	11.05	51.43	74.00	22.57
4874.000	28.19	AV	V	11.05	39.24	54.00	14.76
7311.000	37.42	PK	V	14.80	52.22	74.00	21.78
7311.000	25.21	AV	V	14.80	40.01	54.00	13.99
High Channel: 2462MHz							
2462.000	73.59	PK	H	31.63	105.22	N/A	N/A
2462.000	63.41	AV	H	31.63	95.04	N/A	N/A
2462.000	80.71	PK	V	31.63	112.34	N/A	N/A
2462.000	70.38	AV	V	31.63	102.01	N/A	N/A
2483.500	40.71	PK	V	31.64	72.35	74.00	1.65
2483.500	20.46	AV	V	31.64	52.10	54.00	1.90
4924.000	36.68	PK	V	11.18	47.86	74.00	26.14
4924.000	24.34	AV	V	11.18	35.52	54.00	18.48
7386.000	37.45	PK	V	14.89	52.34	74.00	21.66
7386.000	25.23	AV	V	14.89	40.12	54.00	13.88



**802.11g Mode Chain 1:**

Frequency (MHz)	Receiver		Polar (H/V)	Factor (dB/m)	Result (dB $\mu$ V/m)	Limit (dB $\mu$ V/m)	Margin (dB)
	Reading (dB $\mu$ V)	Detector					
Low Channel: 2412 MHz							
2412.000	72.77	PK	H	31.53	104.30	N/A	N/A
2412.000	62.39	AV	H	31.53	93.92	N/A	N/A
2412.000	81.43	PK	V	31.53	112.96	N/A	N/A
2412.000	71.39	AV	V	31.53	102.92	N/A	N/A
2390.000	40.64	PK	V	31.46	72.10	74.00	1.90
2390.000	19.75	AV	V	31.46	51.21	54.00	2.79
4824.000	39.05	PK	V	10.94	49.99	74.00	24.01
4824.000	27.03	AV	V	10.94	37.97	54.00	16.03
7236.000	37.07	PK	V	14.44	51.51	74.00	22.49
7236.000	25.04	AV	V	14.44	39.48	54.00	14.52
Middle Channel: 2437 MHz							
2437.000	76.49	PK	H	31.60	108.09	N/A	N/A
2437.000	66.28	AV	H	31.60	97.88	N/A	N/A
2437.000	83.11	PK	V	31.60	114.71	N/A	N/A
2437.000	73.36	AV	V	31.60	104.96	N/A	N/A
4874.000	41.27	PK	V	11.05	52.32	74.00	21.68
4874.000	29.14	AV	V	11.05	40.19	54.00	13.81
7311.000	43.79	PK	V	14.80	58.59	74.00	15.41
7311.000	31.40	AV	V	14.80	46.20	54.00	7.80
High Channel: 2462MHz							
2462.000	75.01	PK	H	31.63	106.64	N/A	N/A
2462.000	65.34	AV	H	31.63	96.97	N/A	N/A
2462.000	81.88	PK	V	31.63	113.51	N/A	N/A
2462.000	71.79	AV	V	31.63	103.42	N/A	N/A
2483.500	41.12	PK	V	31.64	72.76	74.00	1.24
2483.500	20.54	AV	V	31.64	52.18	54.00	1.82
4924.000	37.19	PK	V	11.18	48.37	74.00	25.63
4924.000	25.10	AV	V	11.18	36.28	54.00	17.72
7386.000	39.35	PK	V	14.89	54.24	74.00	19.76
7386.000	27.18	AV	V	14.89	42.07	54.00	11.93

**802.11n ht20 Mode(2TX Non-beamforming mode was the worst):**

Frequency (MHz)	Receiver		Polar (H/V)	Factor (dB/m)	Result (dB $\mu$ V/m)	Limit (dB $\mu$ V/m)	Margin (dB)
	Reading (dB $\mu$ V)	Detector					
Low Channel: 2412 MHz							
2412.000	76.65	PK	H	31.53	108.18	N/A	N/A
2412.000	64.33	AV	H	31.53	95.86	N/A	N/A
2412.000	83.62	PK	V	31.53	115.15	N/A	N/A
2412.000	71.89	AV	V	31.53	103.42	N/A	N/A
2390.000	38.92	PK	V	31.46	70.38	74.00	3.62
2390.000	19.36	AV	V	31.46	50.82	54.00	3.18
4824.000	35.78	PK	V	10.94	46.72	74.00	27.28
4824.000	23.39	AV	V	10.94	34.33	54.00	19.67
7236.000	39.77	PK	V	14.44	54.21	74.00	19.79
7236.000	27.39	AV	V	14.44	41.83	54.00	12.17
Middle Channel: 2437 MHz							
2437.000	78.27	PK	H	31.60	109.87	N/A	N/A
2437.000	66.43	AV	H	31.60	98.03	N/A	N/A
2437.000	84.60	PK	V	31.60	116.20	N/A	N/A
2437.000	72.45	AV	V	31.60	104.05	N/A	N/A
4874.000	34.99	PK	V	11.05	46.04	74.00	27.96
4874.000	22.50	AV	V	11.05	33.55	54.00	20.45
7311.000	41.20	PK	V	14.80	56.00	74.00	18.00
7311.000	29.10	AV	V	14.80	43.90	54.00	10.10
High Channel: 2462MHz							
2462.000	77.33	PK	H	31.63	108.96	N/A	N/A
2462.000	65.15	AV	H	31.63	96.78	N/A	N/A
2462.000	82.18	PK	V	31.63	113.81	N/A	N/A
2462.000	70.40	AV	V	31.63	102.03	N/A	N/A
2483.500	39.35	PK	V	31.64	70.99	74.00	3.01
2483.500	19.10	AV	V	31.64	50.74	54.00	3.26
4924.000	33.72	PK	V	11.18	44.90	74.00	29.10
4924.000	21.36	AV	V	11.18	32.54	54.00	21.46
7386.000	36.44	PK	V	14.89	51.33	74.00	22.67
7386.000	24.22	AV	V	14.89	39.11	54.00	14.89

**802.11ax hew20 Mode(2TX Non-beamforming mode was the worst):**

Frequency (MHz)	Receiver		Polar (H/V)	Factor (dB/m)	Result (dB $\mu$ V/m)	Limit (dB $\mu$ V/m)	Margin (dB)
	Reading (dB $\mu$ V)	Detector					
Low Channel: 2412 MHz							
2412.000	76.26	PK	H	31.53	107.79	N/A	N/A
2412.000	64.57	AV	H	31.53	96.10	N/A	N/A
2412.000	84.12	PK	V	31.53	115.65	N/A	N/A
2412.000	72.93	AV	V	31.53	104.46	N/A	N/A
2390.000	41.31	PK	V	31.46	72.77	74.00	1.23
2390.000	18.90	AV	V	31.46	50.36	54.00	3.64
4824.000	36.37	PK	V	10.94	47.31	74.00	26.69
4824.000	24.19	AV	V	10.94	35.13	54.00	18.87
7236.000	37.52	PK	V	14.44	51.96	74.00	22.04
7236.000	25.26	AV	V	14.44	39.70	54.00	14.30
Middle Channel: 2437 MHz							
2437.000	78.66	PK	H	31.60	110.26	N/A	N/A
2437.000	66.12	AV	H	31.60	97.72	N/A	N/A
2437.000	85.58	PK	V	31.60	117.18	N/A	N/A
2437.000	73.46	AV	V	31.60	105.06	N/A	N/A
4874.000	35.29	PK	V	11.05	46.34	74.00	27.66
4874.000	23.15	AV	V	11.05	34.20	54.00	19.80
7311.000	41.13	PK	V	14.80	55.93	74.00	18.07
7311.000	29.07	AV	V	14.80	43.87	54.00	10.13
High Channel: 2462MHz							
2462.000	78.86	PK	H	31.63	110.49	N/A	N/A
2462.000	66.23	AV	H	31.63	97.86	N/A	N/A
2462.000	83.62	PK	V	31.63	115.25	N/A	N/A
2462.000	71.86	AV	V	31.63	103.49	N/A	N/A
2483.500	37.81	PK	V	31.64	69.45	74.00	4.55
2483.500	19.84	AV	V	31.64	51.48	54.00	2.52
4924.000	34.28	PK	V	11.18	45.46	74.00	28.54
4924.000	22.14	AV	V	11.18	33.32	54.00	20.68
7386.000	37.43	PK	V	14.89	52.32	74.00	21.68
7386.000	25.22	AV	V	14.89	40.11	54.00	13.89

**802.11n ht40 Mode(2TX Non-beamforming mode was the worst):**

Frequency (MHz)	Receiver		Polar (H/V)	Factor (dB/m)	Result (dB $\mu$ V/m)	Limit (dB $\mu$ V/m)	Margin (dB)
	Reading (dB $\mu$ V)	Detector					
Low Channel: 2422 MHz							
2422.000	74.59	PK	H	31.56	106.15	N/A	N/A
2422.000	62.17	AV	H	31.56	93.73	N/A	N/A
2422.000	80.33	PK	V	31.56	111.89	N/A	N/A
2422.000	68.53	AV	V	31.56	100.09	N/A	N/A
2390.000	40.80	PK	V	31.46	72.26	74.00	1.74
2390.000	20.53	AV	V	31.46	51.99	54.00	2.01
4844.000	36.02	PK	V	10.96	46.98	74.00	27.02
4844.000	24.01	AV	V	10.96	34.97	54.00	19.03
7266.000	36.07	PK	V	14.63	50.70	74.00	23.30
7266.000	24.04	AV	V	14.63	38.67	54.00	15.33
Middle Channel: 2437 MHz							
2437.000	74.58	PK	H	31.60	106.18	N/A	N/A
2437.000	62.46	AV	H	31.60	94.06	N/A	N/A
2437.000	81.17	PK	V	31.60	112.77	N/A	N/A
2437.000	69.35	AV	V	31.60	100.95	N/A	N/A
4874.000	35.28	PK	V	11.05	46.33	74.00	27.67
4874.000	23.14	AV	V	11.05	34.19	54.00	19.81
7311.000	38.20	PK	V	14.80	53.00	74.00	21.00
7311.000	26.10	AV	V	14.80	40.90	54.00	13.10
High Channel: 2452MHz							
2452.000	73.12	PK	H	31.63	104.75	N/A	N/A
2452.000	61.36	AV	H	31.63	92.99	N/A	N/A
2452.000	80.12	PK	V	31.63	111.75	N/A	N/A
2452.000	68.79	AV	V	31.63	100.42	N/A	N/A
2483.500	34.65	PK	V	31.64	66.29	74.00	7.71
2483.500	18.43	AV	V	31.64	50.07	54.00	3.93
4904.000	35.57	PK	V	11.14	46.71	74.00	27.29
4904.000	23.29	AV	V	11.14	34.43	54.00	19.57
7356.000	35.09	PK	V	14.80	49.89	74.00	24.11
7356.000	23.05	AV	V	14.80	37.85	54.00	16.15

**802.11ax hew40 Mode(2TX Non-beamforming mode was the worst):**

Frequency (MHz)	Receiver		Polar (H/V)	Factor (dB/m)	Result (dB $\mu$ V/m)	Limit (dB $\mu$ V/m)	Margin (dB)
	Reading (dB $\mu$ V)	Detector					
Low Channel: 2422 MHz							
2422.000	74.09	PK	H	31.56	105.65	N/A	N/A
2422.000	62.15	AV	H	31.56	93.71	N/A	N/A
2422.000	81.79	PK	V	31.56	113.35	N/A	N/A
2422.000	69.10	AV	V	31.56	100.66	N/A	N/A
2390.000	40.09	PK	V	31.46	71.55	74.00	2.45
2390.000	20.27	AV	V	31.46	51.73	54.00	2.27
4844.000	35.77	PK	V	10.96	46.73	74.00	27.27
4844.000	23.39	AV	V	10.96	34.35	54.00	19.65
7266.000	35.38	PK	V	14.63	50.01	74.00	23.99
7266.000	23.19	AV	V	14.63	37.82	54.00	16.18
Middle Channel: 2437 MHz							
2437.000	76.64	PK	H	31.60	108.24	N/A	N/A
2437.000	64.37	AV	H	31.60	95.97	N/A	N/A
2437.000	83.64	PK	V	31.60	115.24	N/A	N/A
2437.000	71.25	AV	V	31.60	102.85	N/A	N/A
4874.000	36.65	PK	V	11.05	47.70	74.00	26.30
4874.000	24.33	AV	V	11.05	35.38	54.00	18.62
7311.000	39.36	PK	V	14.80	54.16	74.00	19.84
7311.000	27.18	AV	V	14.80	41.98	54.00	12.02
High Channel: 2452MHz							
2452.000	73.11	PK	H	31.63	104.74	N/A	N/A
2452.000	61.58	AV	H	31.63	93.21	N/A	N/A
2452.000	81.19	PK	V	31.63	112.82	N/A	N/A
2452.000	69.37	AV	V	31.63	101.00	N/A	N/A
2483.500	40.15	PK	V	31.64	71.79	74.00	2.21
2483.500	20.50	AV	V	31.64	52.14	54.00	1.86
4904.000	34.51	PK	V	11.14	45.65	74.00	28.35
4904.000	22.26	AV	V	11.14	33.40	54.00	20.60
7356.000	35.17	PK	V	14.80	49.97	74.00	24.03
7356.000	23.09	AV	V	14.80	37.89	54.00	16.11

**Worst Test plots(802.11b mode chain 1 High channel):**

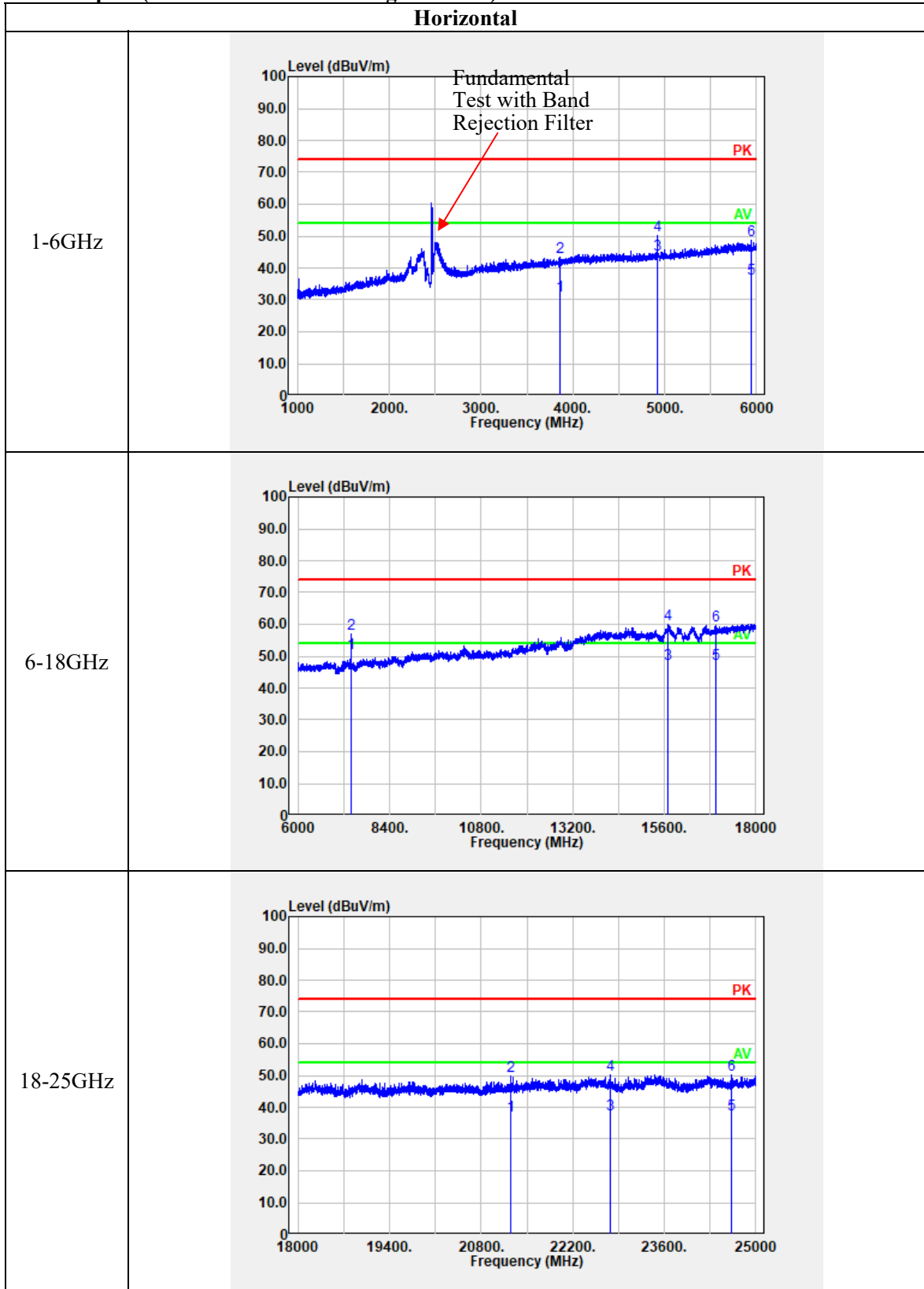

Vertical

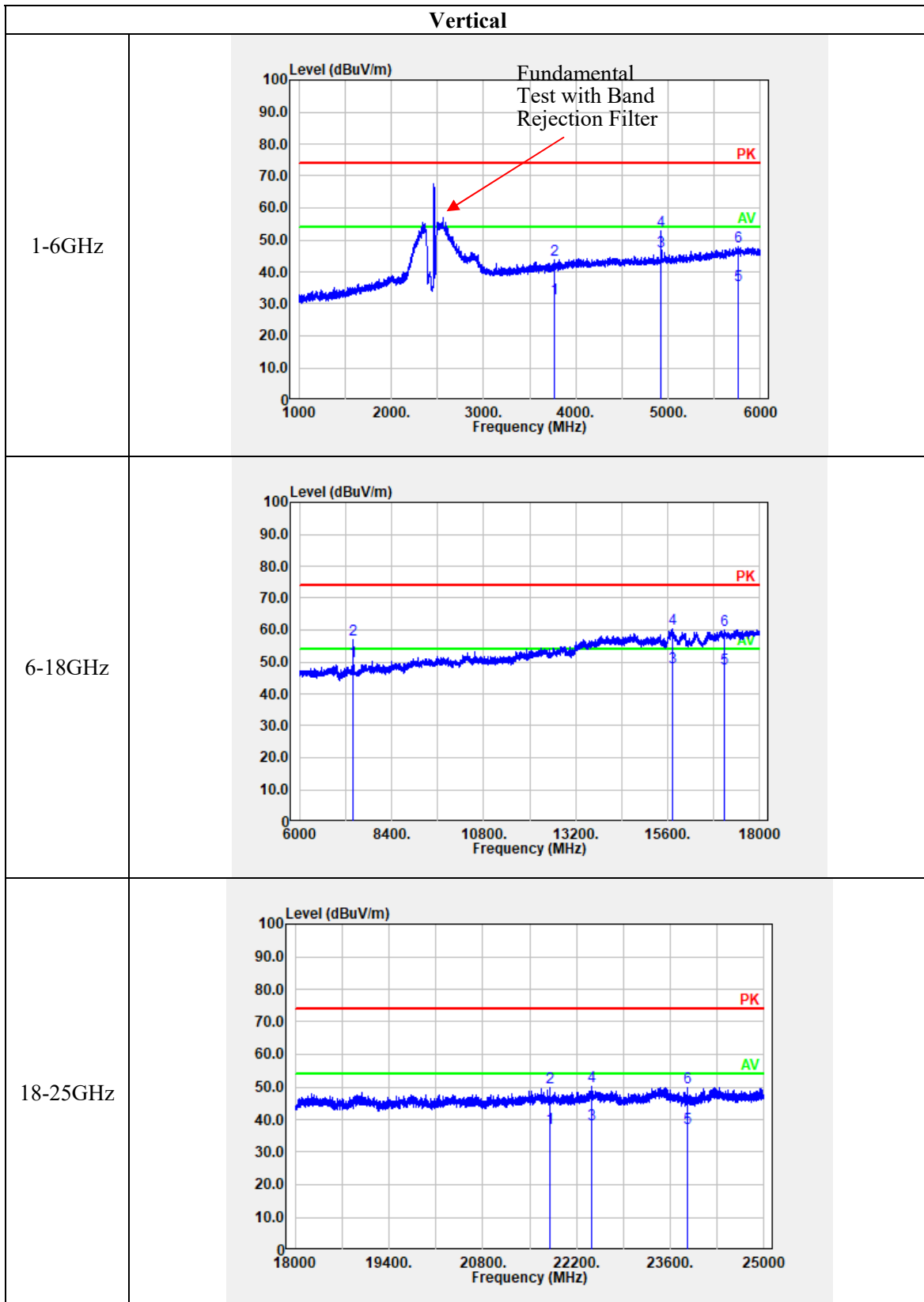

**4.3 Minimum 6 dB Emission Bandwidth:**

Serial Number:	21EC	Test Date:	2023/02/22-2023/03/10
Test Site:	RF	Test Mode:	Transmitting
Tester:	Claire Liu	Test Result:	Pass

**Environmental Conditions:**

Temperature: (°C)	24.8-25.4	Relative Humidity: (%)	49-62	ATM Pressure: (kPa)	101.7-102.2
----------------------	-----------	------------------------------	-------	------------------------	-------------

**Test Equipment List and Details:**

Manufacturer	Description	Model	Serial Number	Calibration Date	Calibration Due Date
R&S	Spectrum Analyzer	FSU26	200256	2022/07/15	2023/07/14
zhuoxiang	Coaxial Cable	SMA-178	211002	Each time	N/A
eastsheep	Coaxial Attenuator	2W-SMA-JK-18G	21060302	Each time	N/A

\* Statement of Traceability: China Certification ICT Co., Ltd (Dongguan) attests that all calibrations have been performed, traceable to National Primary Standards and International System of Units (SI).

**Test Data:**

Test Modes	Test Frequency (MHz)	Minimum 6 dB bandwidth (MHz)	
		Result	Limit
802.11b	2412	7.12	0.5
	2437	7.04	0.5
	2462	7.04	0.5
802.11g	2412	16.48	0.5
	2437	16.48	0.5
	2462	16.40	0.5
802.11n ht20	2412	17.68	0.5
	2437	17.68	0.5
	2462	17.76	0.5
802.11n ht40	2422	36.32	0.5
	2437	36.32	0.5
	2452	36.32	0.5
802.11ax hew20	2412	19.04	0.5
	2437	19.04	0.5
	2462	19.04	0.5
802.11ax hew40	2422	37.92	0.5
	2437	37.92	0.5
	2452	37.92	0.5

Note: Test only was performed at Chain 0.



### 6dB Emission Bandwidth

802.11b  
Lowest Channel

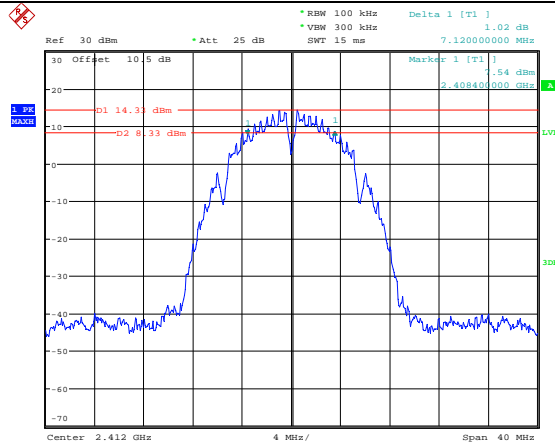

802.11b  
Middle Channel

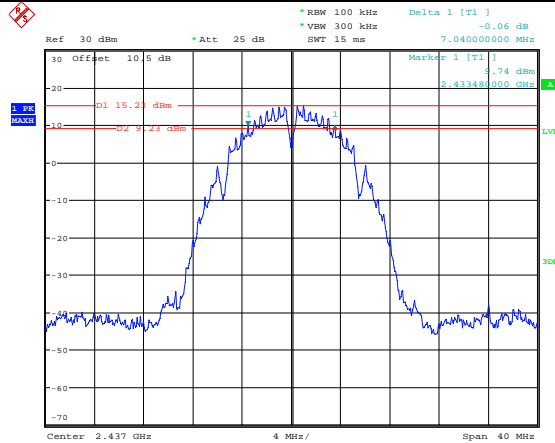

802.11b  
Highest Channel

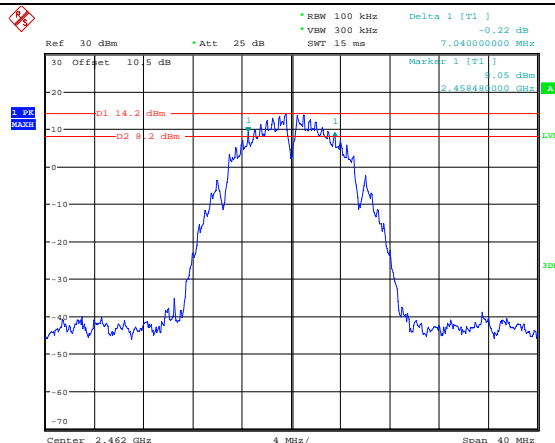

### 6dB Emission Bandwidth

<p>802.11g Lowest Channel</p>	<p>Date: 22.FEB.2023 15:13:04</p>
<p>802.11g Middle Channel</p>	<p>Date: 22.FEB.2023 15:10:39</p>
<p>802.11g Highest Channel</p>	<p>Date: 22.FEB.2023 15:13:46</p>

<b>6dB Emission Bandwidth</b>	
802.11n ht20 Lowest Channel	<p>Ref 30 dBm *Att 25 dB *RBW 100 kHz Delta 1 [T1 ] 2.53 dB *VBM 300 kHz 17.680000000 MHz SWT 15 ms</p> <p>30 Offset 10 5 dB Marker 1 [T1 ] 4.71 dBm 2.403120000 GHz</p> <p>d1 7.85 dBm d2 1.85 dBm</p> <p>Center 2.412 GHz 4 MHz/ Span 40 MHz</p> <p>Date: 22.FEB.2023 15:03:17</p>
802.11n ht20 Middle Channel	<p>Ref 30 dBm *Att 25 dB *RBW 100 kHz Delta 1 [T1 ] 2.49 dB *VBM 300 kHz 17.680000000 MHz SWT 15 ms</p> <p>30 Offset 10 5 dB Marker 1 [T1 ] 1.82 dBm 2.428120000 GHz</p> <p>d1 9.14 dBm d2 3.14 dBm</p> <p>Center 2.437 GHz 4 MHz/ Span 40 MHz</p> <p>Date: 22.FEB.2023 15:02:25</p>
802.11n ht20 Highest Channel	<p>Ref 30 dBm *Att 25 dB *RBW 100 kHz Delta 1 [T1 ] -0.40 dB *VBM 300 kHz 17.760000000 MHz SWT 15 ms</p> <p>30 Offset 10 5 dB Marker 1 [T1 ] 1.40 dBm 2.453120000 GHz</p> <p>d1 7.2 dBm d2 1.2 dBm</p> <p>Center 2.462 GHz 4 MHz/ Span 40 MHz</p> <p>Date: 22.FEB.2023 15:05:44</p>

**6dB Emission Bandwidth**

<p>802.11n ht40 Lowest Channel</p>	<p>Date: 22.FEB.2023 15:00:27</p>
<p>802.11n ht40 Middle Channel</p>	<p>Date: 22.FEB.2023 15:01:23</p>
<p>802.11n ht40 Highest Channel</p>	<p>Date: 22.FEB.2023 14:59:52</p>

<b>6dB Emission Bandwidth</b>	
802.11ax hew20 Lowest Channel	<p style="text-align: center;">Date: 10.MAR.2023 09:26:45</p>
802.11ax hew20 Middle Channel	<p style="text-align: center;">Date: 10.MAR.2023 09:27:57</p>
802.11ax hew20 Highest Channel	<p style="text-align: center;">Date: 10.MAR.2023 09:29:39</p>

### 6dB Emission Bandwidth

<p>802.11ax hew40 Lowest Channel</p>	<p>Date: 10.MAR.2023 09:32:49</p>
<p>802.11ax hew40 Middle Channel</p>	<p>Date: 10.MAR.2023 09:35:11</p>
<p>802.11ax hew40 Highest Channel</p>	<p>Date: 10.MAR.2023 09:37:39</p>

**4.4 99% Occupied Bandwidth:**

Serial Number:	21EC	Test Date:	2023/02/22-2023/03/10
Test Site:	RF	Test Mode:	Transmitting
Tester:	Claire Liu	Test Result:	N/A

**Environmental Conditions:**

Temperature: (°C)	24.8-25.4	Relative Humidity: (%)	49-62	ATM Pressure: (kPa)	101.7-102.2
----------------------	-----------	------------------------------	-------	------------------------	-------------

**Test Equipment List and Details:**

Manufacturer	Description	Model	Serial Number	Calibration Date	Calibration Due Date
R&S	Spectrum Analyzer	FSU26	200256	2022/07/15	2023/07/14
zhuoxiang	Coaxial Cable	SMA-178	211002	Each time	N/A
eastsheep	Coaxial Attenuator	2W-SMA-JK-18G	21060302	Each time	N/A

\* Statement of Traceability: China Certification ICT Co., Ltd (Dongguan) attests that all calibrations have been performed, traceable to National Primary Standards and International System of Units (SI).

**Test Data:**

Test Modes	Test Channel	Test Frequency (MHz)	99% Occupied Bandwidth (MHz)
802.11b	Lowest	2412	10.56
	Middle	2437	10.56
	Highest	2462	10.56
802.11g	Lowest	2412	17.12
	Middle	2437	17.28
	Highest	2462	17.20
802.11n ht20	Lowest	2412	18.16
	Middle	2437	18.16
	Highest	2462	18.08
802.11n ht40	Lowest	2422	36.48
	Middle	2437	36.48
	Highest	2452	36.32
802.11ax hew20	Lowest	2412	19.20
	Middle	2437	19.20
	Highest	2462	19.20
802.11ax hew40	Lowest	2422	37.76
	Middle	2437	37.76
	Highest	2452	37.76

Note: Test only was performed at Chain 0.

**99% Occupied Bandwidth**

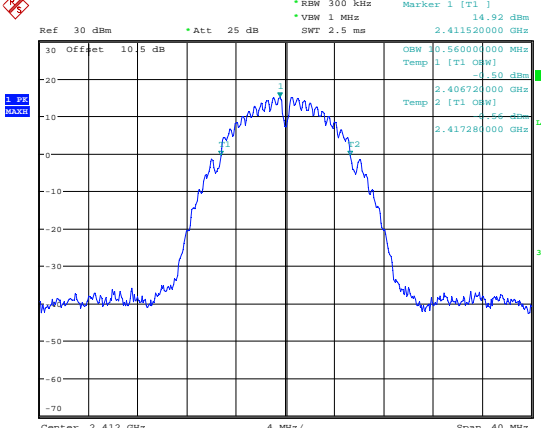
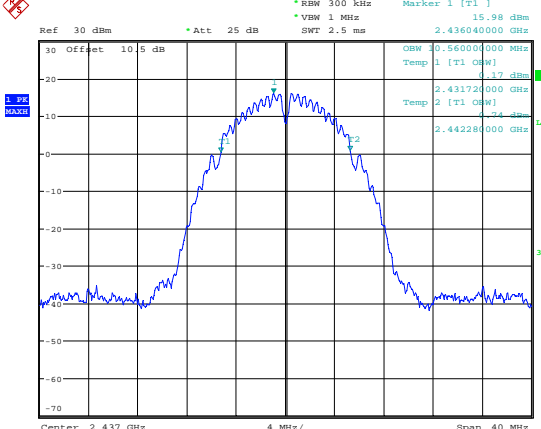
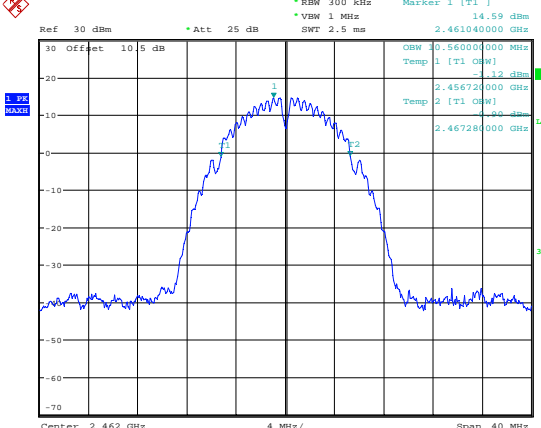
<p>802.11b Lowest Channel</p>	 <p>Ref: 30 dBm, Offset: 10.5 dB, Att: 25 dB, RBW: 300 kHz, VBW: 1 MHz, SWT: 2.5 ms, Marker 1 [T1]: 2.411520000 GHz, 14.92 dBm</p> <p>OSW: 0.560000000 MHz, Temp 1 [T1 OSW]: -1.50 dBm, 2.406720000 GHz, Temp 2 [T1 OSW]: -5.56 dBm, 2.417280000 GHz</p> <p>Center: 2.412 GHz, 4 MHz/, Span: 40 MHz</p> <p>Date: 22.FEB.2023 15:07:16</p>
<p>802.11b Middle Channel</p>	 <p>Ref: 30 dBm, Offset: 10.5 dB, Att: 25 dB, RBW: 300 kHz, VBW: 1 MHz, SWT: 2.5 ms, Marker 1 [T1]: 2.436040000 GHz, 15.98 dBm</p> <p>OSW: 0.560000000 MHz, Temp 1 [T1 OSW]: -1.17 dBm, 2.431720000 GHz, Temp 2 [T1 OSW]: -1.24 dBm, 2.442280000 GHz</p> <p>Center: 2.437 GHz, 4 MHz/, Span: 40 MHz</p> <p>Date: 22.FEB.2023 15:09:54</p>
<p>802.11b Highest Channel</p>	 <p>Ref: 30 dBm, Offset: 10.5 dB, Att: 25 dB, RBW: 300 kHz, VBW: 1 MHz, SWT: 2.5 ms, Marker 1 [T1]: 2.461040000 GHz, 14.59 dBm</p> <p>OSW: 0.560000000 MHz, Temp 1 [T1 OSW]: -1.12 dBm, 2.456720000 GHz, Temp 2 [T1 OSW]: -1.20 dBm, 2.467280000 GHz</p> <p>Center: 2.462 GHz, 4 MHz/, Span: 40 MHz</p> <p>Date: 22.FEB.2023 15:08:15</p>

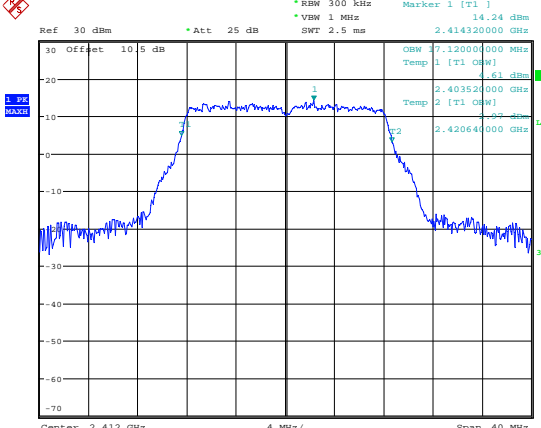
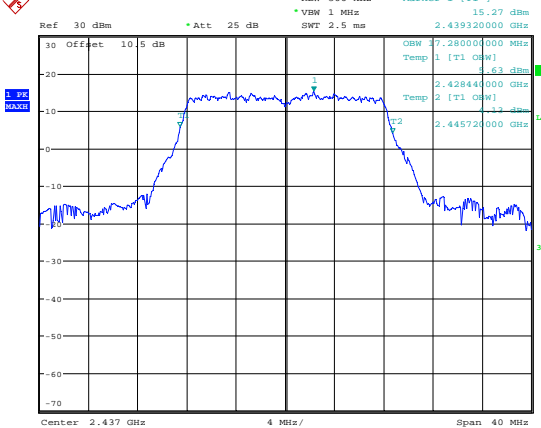
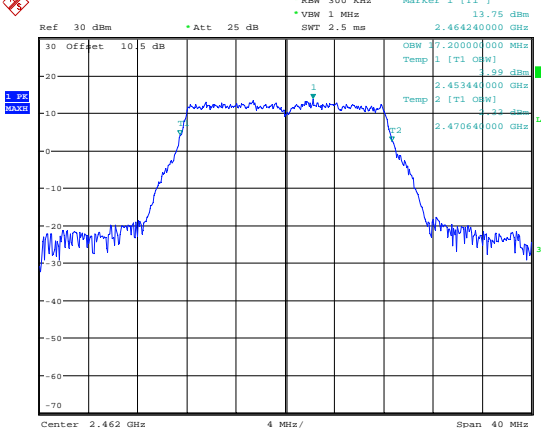

**99% Occupied Bandwidth**

<p>802.11g Lowest Channel</p>	 <p>Ref 30 dBm * Att 25 dB * RBW 300 kHz Marker 1 [T1] 14.24 dBm * VBW 1 MHz 2.414320000 GHz SWT 2.5 ms</p> <p>30 Offset 10.5 dB * RBW 300 kHz Marker 1 [T1] 14.24 dBm Temp 1 [T1] 0.61 dBm 2.403520000 GHz Temp 2 [T1] 0.00 dBm 2.420640000 GHz</p> <p>Center 2.412 GHz 4 MHz/ Span 40 MHz</p> <p>Date: 22.FEB.2023 15:12:41</p>
<p>802.11g Middle Channel</p>	 <p>Ref 30 dBm * Att 25 dB * RBW 300 kHz Marker 1 [T1] 15.27 dBm * VBW 1 MHz 2.439320000 GHz SWT 2.5 ms</p> <p>30 Offset 10.5 dB * RBW 300 kHz Marker 1 [T1] 15.27 dBm Temp 1 [T1] 0.63 dBm 2.428440000 GHz Temp 2 [T1] 0.00 dBm 2.445720000 GHz</p> <p>Center 2.437 GHz 4 MHz/ Span 40 MHz</p> <p>Date: 22.FEB.2023 15:11:08</p>
<p>802.11g Highest Channel</p>	 <p>Ref 30 dBm * Att 25 dB * RBW 300 kHz Marker 1 [T1] 13.75 dBm * VBW 1 MHz 2.464240000 GHz SWT 2.5 ms</p> <p>30 Offset 10.5 dB * RBW 300 kHz Marker 1 [T1] 13.75 dBm Temp 1 [T1] 0.89 dBm 2.453440000 GHz Temp 2 [T1] 0.00 dBm 2.470640000 GHz</p> <p>Center 2.462 GHz 4 MHz/ Span 40 MHz</p> <p>Date: 22.FEB.2023 15:14:02</p>

**99% Occupied Bandwidth**

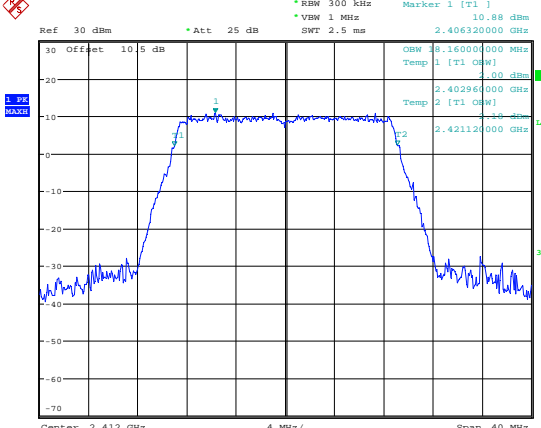
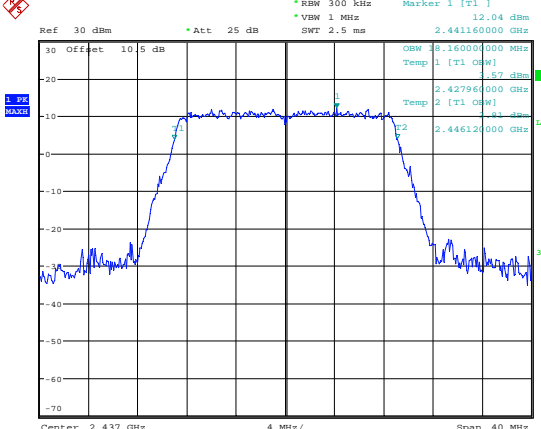
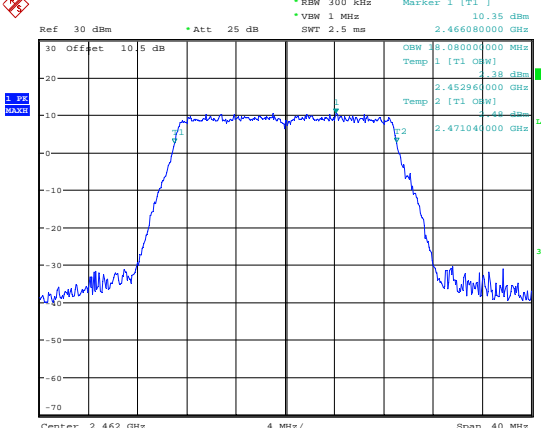
<p>802.11n ht20 Lowest Channel</p>	 <p>Ref 30 dBm *Att 25 dB *RBW 300 kHz Marker 1 [T1] 10.88 dBm *VBW 1 MHz 2.406320000 GHz SWT 2.5 ms</p> <p>30 Offset 10 5 dB</p> <p>30.160000000 MHz Temp 1 [T1] 0.00 dBm 2.402960000 GHz Temp 2 [T1] 0.00 dBm 2.421120000 GHz</p> <p>Center 2.412 GHz 4 MHz/ Span 40 MHz</p> <p>Date: 22.FEB.2023 15:03:33</p>
<p>802.11n ht20 Middle Channel</p>	 <p>Ref 30 dBm *Att 25 dB *RBW 300 kHz Marker 1 [T1] 12.04 dBm *VBW 1 MHz 2.441160000 GHz SWT 2.5 ms</p> <p>30 Offset 10 5 dB</p> <p>30.160000000 MHz Temp 1 [T1] 0.57 dBm 2.427960000 GHz Temp 2 [T1] 0.83 dBm 2.446120000 GHz</p> <p>Center 2.437 GHz 4 MHz/ Span 40 MHz</p> <p>Date: 22.FEB.2023 15:02:41</p>
<p>802.11n ht20 Highest Channel</p>	 <p>Ref 30 dBm *Att 25 dB *RBW 300 kHz Marker 1 [T1] 10.35 dBm *VBW 1 MHz 2.466080000 GHz SWT 2.5 ms</p> <p>30 Offset 10 5 dB</p> <p>30.080000000 MHz Temp 1 [T1] 1.38 dBm 2.452960000 GHz Temp 2 [T1] 1.48 dBm 2.471040000 GHz</p> <p>Center 2.462 GHz 4 MHz/ Span 40 MHz</p> <p>Date: 22.FEB.2023 15:04:27</p>

**99% Occupied Bandwidth**

<p>802.11n ht40 Lowest Channel</p>	<p>Ref 30 dBm *Att 25 dB *RBW 500 kHz Marker 1 [T1] 9.86 dBm          *VBM 2 MHz 2.423760000 GHz          *SWT 2.5 ms</p> <p>30 Offset 10 5 dB</p> <p>1 P1 MAXI</p> <p>OSW 6.48000000 MHz          Temp 1 [T1 OSW] 1.82 dBm          2.403760000 GHz          Temp 2 [T1 OSW] 1.83 dBm          2.440240000 GHz</p> <p>Center 2.422 GHz 8 MHz/ Span 80 MHz</p> <p>Date: 22.FEB.2023 15:00:43</p>
<p>802.11n ht40 Middle Channel</p>	<p>Ref 30 dBm *Att 25 dB *RBW 500 kHz Marker 1 [T1] 11.07 dBm          *VBM 2 MHz 2.441960000 GHz          *SWT 2.5 ms</p> <p>30 Offset 10 5 dB</p> <p>1 P1 MAXI</p> <p>OSW 6.48000000 MHz          Temp 1 [T1 OSW] 4.04 dBm          2.418920000 GHz          Temp 2 [T1 OSW] 4.03 dBm          2.455400000 GHz</p> <p>Center 2.437 GHz 8 MHz/ Span 80 MHz</p> <p>Date: 22.FEB.2023 15:01:40</p>
<p>802.11n ht40 Highest Channel</p>	<p>Ref 30 dBm *Att 25 dB *RBW 500 kHz Marker 1 [T1] 9.93 dBm          *VBM 2 MHz 2.453920000 GHz          *SWT 2.5 ms</p> <p>30 Offset 10 5 dB</p> <p>1 P1 MAXI</p> <p>OSW 6.32000000 MHz          Temp 1 [T1 OSW] 4.42 dBm          2.433920000 GHz          Temp 2 [T1 OSW] 4.13 dBm          2.470240000 GHz</p> <p>Center 2.452 GHz 8 MHz/ Span 80 MHz</p> <p>Date: 22.FEB.2023 14:59:29</p>

**99% Occupied Bandwidth**

<p>802.11ax hew20 Lowest Channel</p>	<p>Ref 30 dBm *Att 25 dB RBW 300 kHz Marker 1 [T1] 12.20 dBm          *VSW 1 MHz 2.409120000 GHz          SWT 2.5 ms          Offset 10.5 dB          Center 2.412 GHz 4 MHz/ Span 40 MHz          Date: 10.MAR.2023 09:27:06</p>
<p>802.11ax hew20 Middle Channel</p>	<p>Ref 30 dBm *Att 25 dB RBW 300 kHz Marker 1 [T1] 14.45 dBm          *VSW 1 MHz 2.434120000 GHz          SWT 2.5 ms          Offset 10.5 dB          Center 2.437 GHz 4 MHz/ Span 40 MHz          Date: 10.MAR.2023 09:28:15</p>
<p>802.11ax hew20 Highest Channel</p>	<p>Ref 30 dBm *Att 25 dB RBW 300 kHz Marker 1 [T1] 12.99 dBm          *VSW 1 MHz 2.459120000 GHz          SWT 2.5 ms          Offset 10.5 dB          Center 2.462 GHz 4 MHz/ Span 40 MHz          Date: 10.MAR.2023 09:29:14</p>

**99% Occupied Bandwidth**

<p>802.11ax hew40 Lowest Channel</p>	<p>Ref 30 dBm * Att 25 dB * RBW 500 kHz Marker 1 [T1 ]          * VBW 2 MHz 13.08 dBm          SWT 2.5 ms 2.418640000 GHz</p> <p>OBW 2.760000000 MHz          Temp 1 [T1 OBW] 1.87 dBm          2.403120000 GHz          Temp 2 [T1 OBW] 1.56 dBm          2.440880000 GHz</p> <p>Center 2.422 GHz 8 MHz/ Span 80 MHz</p> <p>Date: 10.MAR.2023 09:31:43</p>
<p>802.11ax hew40 Middle Channel</p>	<p>Ref 30 dBm * Att 25 dB * RBW 500 kHz Marker 1 [T1 ]          * VBW 2 MHz 14.28 dBm          SWT 2.5 ms 2.433480000 GHz</p> <p>OBW 2.760000000 MHz          Temp 1 [T1 OBW] 1.56 dBm          2.418120000 GHz          Temp 2 [T1 OBW] 1.43 dBm          2.455880000 GHz</p> <p>Center 2.437 GHz 8 MHz/ Span 80 MHz</p> <p>Date: 10.MAR.2023 09:36:40</p>
<p>802.11ax hew40 Highest Channel</p>	<p>Ref 30 dBm * Att 25 dB * RBW 500 kHz Marker 1 [T1 ]          * VBW 2 MHz 12.76 dBm          SWT 2.5 ms 2.448480000 GHz</p> <p>OBW 2.760000000 MHz          Temp 1 [T1 OBW] 1.00 dBm          2.433120000 GHz          Temp 2 [T1 OBW] 1.26 dBm          2.470880000 GHz</p> <p>Center 2.452 GHz 8 MHz/ Span 80 MHz</p> <p>Date: 10.MAR.2023 09:38:00</p>

**4.5 Maximum Conducted Output Power:**

Serial Number:	21EC	Test Date:	2023/02/22-2023/03/10
Test Site:	RF	Test Mode:	Transmitting
Tester:	Claire Liu	Test Result:	Pass

**Environmental Conditions:**

Temperature: (°C)	24.8-25.4	Relative Humidity: (%)	49-62	ATM Pressure: (kPa)	101.7-102.2
----------------------	-----------	------------------------------	-------	------------------------	-------------

**Test Equipment List and Details:**

Manufacturer	Description	Model	Serial Number	Calibration Date	Calibration Due Date
Agilent	USB Wideband Power Sensor	U2021XA	MY54080015	2022/07/15	2023/07/14
zhuoxiang	Coaxial Cable	SMA-178	211002	Each time	N/A
eastsheep	Coaxial Attenuator	2W-SMA-JK-18G	21060302	Each time	N/A

\* Statement of Traceability: China Certification ICT Co., Ltd (Dongguan) attests that all calibrations have been performed, traceable to National Primary Standards and International System of Units (SI).

**Test Data:**

Test Modes	Test Frequency (MHz)	Maximum Conducted Average Output Power (dBm)			
		Chain 0	Chain 1	Total	Limit
802.11b	2412	22.67	21.46	/	30
	2437	23.79	22.37	/	30
	2462	22.31	21.04	/	30
802.11g	2412	22.72	19.66	/	30
	2437	23.73	22.99	/	30
	2462	21.06	19.14	/	30
802.11n ht20	2412	20.08	19.78	22.94	28.16
	2437	21.26	20.49	23.90	28.16
	2462	19.85	19.24	22.57	28.16
802.11n ht40	2422	19.62	18.92	22.29	28.16
	2437	20.45	19.78	23.14	28.16
	2452	19.36	18.43	21.93	28.16
802.11ax hew20	2412	19.76	19.22	22.51	28.16
	2437	22.18	21.14	<b>24.70</b>	28.16
	2462	20.58	19.87	23.25	28.16
802.11ax hew40	2422	19.94	19.39	22.68	28.16
	2437	20.97	20.37	23.69	28.16
	2452	18.95	18.76	21.87	28.16

Note: The device employed Cyclic Delay Diversity (CDD) for 802.11 MIMO transmitting, per KDB 662911 D01 Multiple Transmitter Output v02r01, for power measurements on IEEE 802.11 devices:

Array Gain = 0 dB (i.e., no array gain) for  $N_{ANT} \leq 4$

So:

For Non-beamforming mode:

Directional gain = 4.84 dBi

For Beamforming mode:

Directional gain = 4.84+3 = 7.84 dBi

The worst limit Beamforming mode was used in the table.

**4.6 Maximum power spectral density:**

Serial Number:	21EC	Test Date:	2023/4/6-2023/4/7
Test Site:	RF	Test Mode:	Transmitting
Tester:	Claire Liu	Test Result:	Pass

**Environmental Conditions:**

Temperature: (°C)	25.6-26.3	Relative Humidity: (%)	58-61	ATM Pressure: (kPa)	100.4-100.5
----------------------	-----------	------------------------------	-------	------------------------	-------------

**Test Equipment List and Details:**

Manufacturer	Description	Model	Serial Number	Calibration Date	Calibration Due Date
R&S	Spectrum Analyzer	FSU26	200256	2022/07/15	2023/07/14
zhuoxiang	Coaxial Cable	SMA-178	211002	Each time	N/A
eastsheep	Coaxial Attenuator	2W-SMA-JK-18G	21060302	Each time	N/A

\* *Statement of Traceability: China Certification ICT Co., Ltd (Dongguan) attests that all calibrations have been performed, traceable to National Primary Standards and International System of Units (SI).*



**Test Data:**

Test Modes	Test Frequency (MHz)	Reading (dBm/10kHz)		Duty Cycle Factor (dB)	Maximum Power Spectral Density (dBm/10kHz)	Limit (dBm/3kHz)
		Chain 0	Chain 1			
802.11b	2412	-7.20	-5.82	0.16	-5.66	8.00
	2437	-6.12	-5.77	0.16	-5.61	8.00
	2462	-7.32	-7.35	0.16	-7.16	8.00
802.11g	2412	-9.52	-8.13	0.16	-7.97	8.00
	2437	-8.24	-6.74	0.16	-6.58	8.00
	2462	-10.32	-8.70	0.16	-8.54	8.00
802.11n ht20	2412	-10.61	-10.57	0.35	-7.23	3.16
	2437	-9.67	-9.31	0.35	-6.13	3.16
	2462	-11.14	-11.03	0.35	-7.72	3.16
802.11n ht40	2422	-13.66	-12.22	0.72	-9.15	3.16
	2437	-13.22	-11.89	0.72	-8.77	3.16
	2452	-13.65	-13.30	0.72	-9.74	3.16
802.11ax hew20	2412	-10.47	-9.97	/	-7.20	3.16
	2437	-8.57	-8.78	/	-5.66	3.16
	2462	-9.85	-10.20	/	-7.01	3.16
802.11ax hew40	2422	-13.61	-12.29	0.20	-9.69	3.16
	2437	-11.45	-11.36	0.20	-8.19	3.16
	2452	-14.18	-13.08	0.20	-10.38	3.16

**Note:**

Duty cycle  $\geq 98\%$ , method ANSI C63.10-2013 Section 11.10.3 was used.

Duty cycle  $< 98\%$ , and duty cycle variations are less than  $\pm 2\%$ , method ANSI C63.10-2013 Section 11.10.5 was used.

Duty cycle  $< 98\%$ , and duty cycle variations exceed  $\pm 2\%$ , method ANSI C63.10-2013 Section 11.10.7.

For Duty cycle  $< 98\%$ , and Duty cycle be considered to be constant (variations are less than  $\pm 2\%$ ), the duty cycle factor was added into the result.

The maximum Power Spectral Density was calculated the result of the maximum chain for SISO mode, and Total chains for MIMO mode.

The device employed Cyclic Delay Diversity (CDD) for 802.11 MIMO transmitting, per KDB 662911 D01 Multiple Transmitter Output v02r01, for power spectral density (PSD) measurements on the devices:

$$\text{Array Gain} = 10 \log(N_{\text{ANT}}/N_{\text{SS}}) \text{ dB.}$$

So:

Directional gain =  $G_{\text{ANT}} + \text{Array Gain} = 4.84 + 10 * \log(2/1) = 7.84 \text{ dBi}$  for Non-beamforming mode

Directional gain =  $G_{\text{ANT}} + \text{Array Gain} = 4.84 + 3 + 10 * \log(2/1) = 10.84 \text{ dBi}$  for Beamforming mode

The worst limit Beamforming mode was used in the table.

Chain 0:

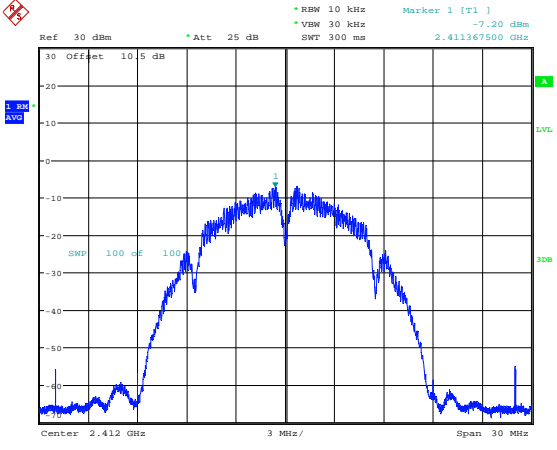
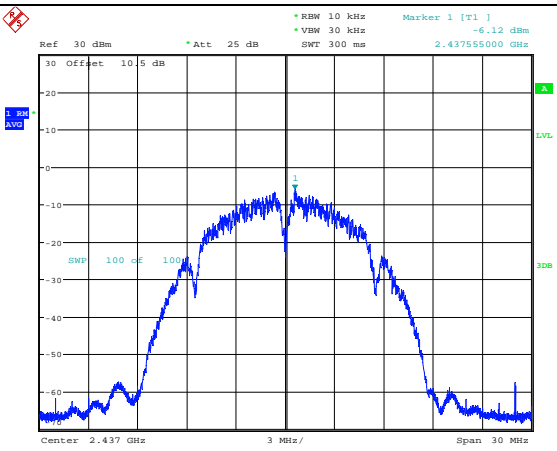
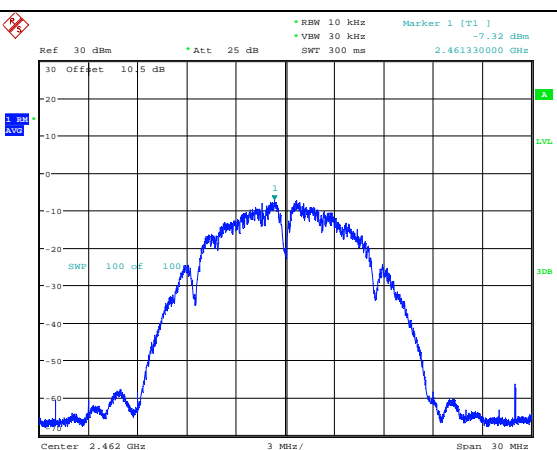
Maximum power spectral density	
802.11b Lowest Channel	 <p>Ref 30 dBm *Att 25 dB RBW 10 kHz Marker 1 [T1] -7.20 dBm *VSW 30 kHz 2.411367500 GHz SWT 300 ms</p> <p>30 Offset 10.5 dB</p> <p>20</p> <p>10</p> <p>0</p> <p>-10</p> <p>-20</p> <p>-30</p> <p>-40</p> <p>-50</p> <p>-60</p> <p>SWP 100 cF 100</p> <p>3dB</p> <p>AVG</p> <p>Center 2.412 GHz 3 MHz/ Span 30 MHz</p> <p>Date: 6.APR.2023 09:45:42</p>
802.11b Middle Channel	 <p>Ref 30 dBm *Att 25 dB RBW 10 kHz Marker 1 [T1] -6.12 dBm *VSW 30 kHz 2.437555000 GHz SWT 300 ms</p> <p>30 Offset 10.5 dB</p> <p>20</p> <p>10</p> <p>0</p> <p>-10</p> <p>-20</p> <p>-30</p> <p>-40</p> <p>-50</p> <p>-60</p> <p>SWP 100 cF 100</p> <p>3dB</p> <p>AVG</p> <p>Center 2.437 GHz 3 MHz/ Span 30 MHz</p> <p>Date: 6.APR.2023 09:48:09</p>
802.11b Highest Channel	 <p>Ref 30 dBm *Att 25 dB RBW 10 kHz Marker 1 [T1] -7.32 dBm *VSW 30 kHz 2.461330000 GHz SWT 300 ms</p> <p>30 Offset 10.5 dB</p> <p>20</p> <p>10</p> <p>0</p> <p>-10</p> <p>-20</p> <p>-30</p> <p>-40</p> <p>-50</p> <p>-60</p> <p>SWP 100 cF 100</p> <p>3dB</p> <p>AVG</p> <p>Center 2.462 GHz 3 MHz/ Span 30 MHz</p> <p>Date: 6.APR.2023 09:54:14</p>

### Maximum power spectral density

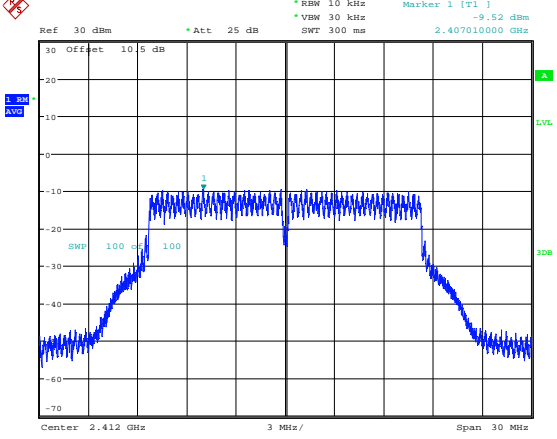
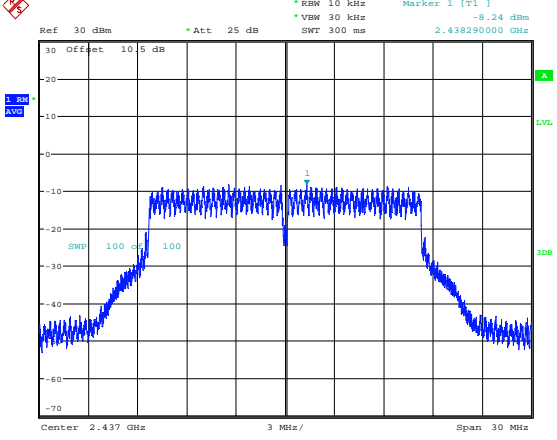
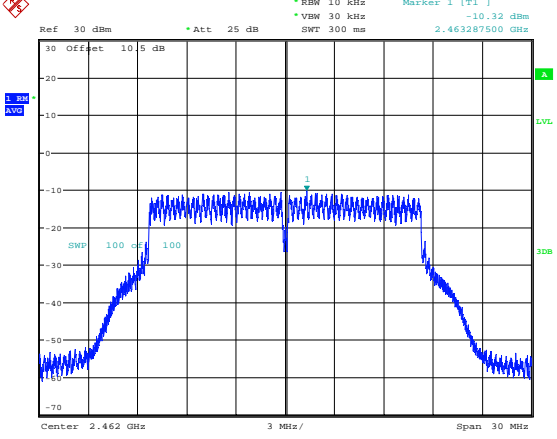
<p>802.11g Lowest Channel</p>	 <p>Ref 30 dBm *Att 25 dB *RBW 10 kHz Marker 1 [T1] -9.52 dBm *VBW 30 kHz *SWT 300 ms 2.407010000 GHz</p> <p>30 Offset 10 5 dB</p> <p>30 20 10 0 -10 -20 -30 -40 -50 -60 -70</p> <p>1. PM AVG</p> <p>SWP 100 c 100</p> <p>1</p> <p>LVL</p> <p>3dB</p> <p>Center 2.412 GHz 3 MHz/ Span 30 MHz</p> <p>Date: 6.APR.2023 10:02:34</p>
<p>802.11g Middle Channel</p>	 <p>Ref 30 dBm *Att 25 dB *RBW 10 kHz Marker 1 [T1] -8.24 dBm *VBW 30 kHz *SWT 300 ms 2.438290000 GHz</p> <p>30 Offset 10 5 dB</p> <p>30 20 10 0 -10 -20 -30 -40 -50 -60 -70</p> <p>1. PM AVG</p> <p>SWP 100 c 100</p> <p>1</p> <p>LVL</p> <p>3dB</p> <p>Center 2.437 GHz 3 MHz/ Span 30 MHz</p> <p>Date: 6.APR.2023 10:04:24</p>
<p>802.11g Highest Channel</p>	 <p>Ref 30 dBm *Att 25 dB *RBW 10 kHz Marker 1 [T1] -10.32 dBm *VBW 30 kHz *SWT 300 ms 2.463297500 GHz</p> <p>30 Offset 10 5 dB</p> <p>30 20 10 0 -10 -20 -30 -40 -50 -60 -70</p> <p>1. PM AVG</p> <p>SWP 100 c 100</p> <p>1</p> <p>LVL</p> <p>3dB</p> <p>Center 2.462 GHz 3 MHz/ Span 30 MHz</p> <p>Date: 6.APR.2023 10:08:28</p>

**Maximum power spectral density**

<p>802.11n ht20 Lowest Channel</p>	<p>Ref: 30 dBm    *Att: 25 dB    *RBW: 10 kHz    Marker 1 [T1]    -10.61 dBm          *VBW: 30 kHz    *SWT: 300 ms    2.406565000 GHz</p> <p>Center: 2.412 GHz    3 MHz/    Span: 30 MHz</p> <p>Date: 6.APR.2023 10:11:58</p>
<p>802.11n ht20 Middle Channel</p>	<p>Ref: 30 dBm    *Att: 25 dB    *RBW: 10 kHz    Marker 1 [T1]    -9.67 dBm          *VBW: 30 kHz    *SWT: 300 ms    2.429510000 GHz</p> <p>Center: 2.437 GHz    3 MHz/    Span: 30 MHz</p> <p>Date: 6.APR.2023 10:15:55</p>
<p>802.11n ht20 Highest Channel</p>	<p>Ref: 30 dBm    *Att: 25 dB    *RBW: 10 kHz    Marker 1 [T1]    -11.14 dBm          *VBW: 30 kHz    *SWT: 300 ms    2.457007500 GHz</p> <p>Center: 2.462 GHz    3 MHz/    Span: 30 MHz</p> <p>Date: 6.APR.2023 10:14:13</p>

### Maximum power spectral density

<p>802.11n ht40 Lowest Channel</p>	<p>Ref: 30 dBm    *Att: 25 dB    *RBW: 10 kHz    Marker 1 [T1]    -13.66 dBm          *VBW: 30 kHz    SWT: 600 ms    2.410720000 GHz</p> <p>Center: 2.422 GHz    6 MHz/    Span: 60 MHz</p> <p>Date: 6.APR.2023 10:19:35</p>
<p>802.11n ht40 Middle Channel</p>	<p>Ref: 30 dBm    *Att: 25 dB    *RBW: 10 kHz    Marker 1 [T1]    -13.22 dBm          *VBW: 30 kHz    SWT: 600 ms    2.425710000 GHz</p> <p>Center: 2.437 GHz    6 MHz/    Span: 60 MHz</p> <p>Date: 6.APR.2023 10:25:03</p>
<p>802.11n ht40 Highest Channel</p>	<p>Ref: 30 dBm    *Att: 25 dB    *RBW: 10 kHz    Marker 1 [T1]    -13.65 dBm          *VBW: 30 kHz    SWT: 600 ms    2.444465000 GHz</p> <p>Center: 2.452 GHz    6 MHz/    Span: 60 MHz</p> <p>Date: 6.APR.2023 10:22:24</p>

### Maximum power spectral density

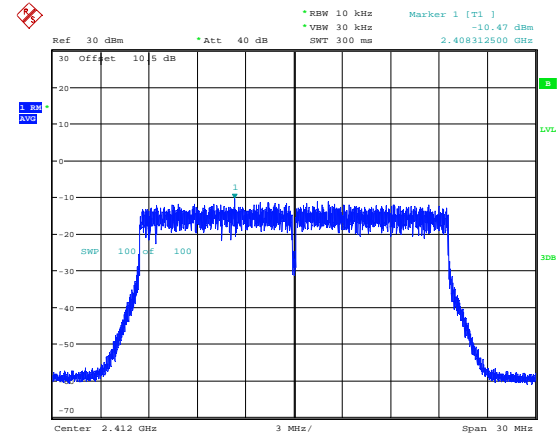
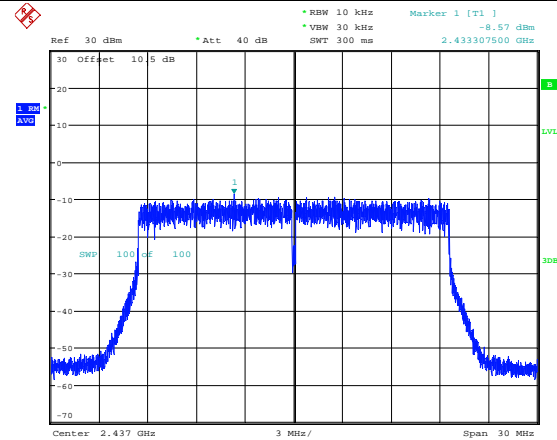
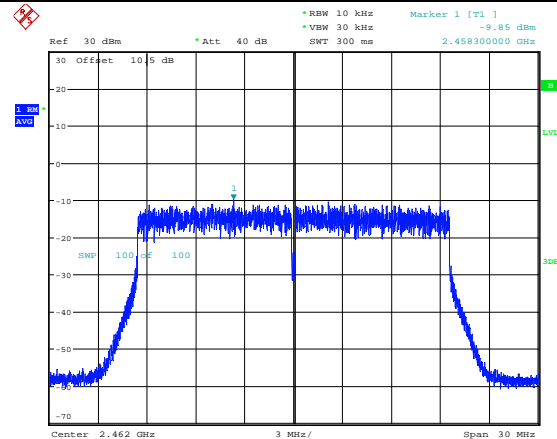
<p>802.11ax hew20 Lowest Channel</p>	 <p>Date: 7.APR.2023 14:08:36</p>
<p>802.11ax hew20 Middle Channel</p>	 <p>Date: 7.APR.2023 14:10:13</p>
<p>802.11ax hew20 Highest Channel</p>	 <p>Date: 7.APR.2023 14:23:19</p>

**Maximum power spectral density**

<p>802.11ax hew40 Lowest Channel</p>	<p>Ref: 30 dBm    *Att: 25 dB    *RBW: 10 kHz    Marker 1 [T1]    -19.61 dBm          *VBM: 30 kHz          *SWF: 600 ms    2.425105000 GHz</p> <p>Center: 2.422 GHz    6 MHz/    Span: 60 MHz</p> <p>Date: 6.APR.2023 10:31:16</p>
<p>802.11ax hew40 Middle Channel</p>	<p>Ref: 30 dBm    *Att: 25 dB    *RBW: 10 kHz    Marker 1 [T1]    -11.45 dBm          *VBM: 30 kHz          *SWF: 600 ms    2.440105000 GHz</p> <p>Center: 2.437 GHz    6 MHz/    Span: 60 MHz</p> <p>Date: 6.APR.2023 10:29:04</p>
<p>802.11ax hew40 Highest Channel</p>	<p>Ref: 30 dBm    *Att: 25 dB    *RBW: 10 kHz    Marker 1 [T1]    -14.18 dBm          *VBM: 30 kHz          *SWF: 600 ms    2.455105000 GHz</p> <p>Center: 2.452 GHz    6 MHz/    Span: 60 MHz</p> <p>Date: 6.APR.2023 10:33:12</p>

Chain 1:

<b>Maximum power spectral density</b>	
<p>802.11b Lowest Channel</p>	<p>Ref 30 dBm *Att 25 dB *RBW 10 kHz *VSW 30 kHz *SWT 300 ms Marker 1 [T1] -5.82 dBm 2.412672500 GHz</p> <p>30 Offset 10.5 dB</p> <p>SWP 100 dB 100</p> <p>Center 2.412 GHz 3 MHz/ Span 30 MHz</p> <p>Date: 6.APR.2023 11:15:34</p>
<p>802.11b Middle Channel</p>	<p>Ref 30 dBm *Att 25 dB *RBW 10 kHz *VSW 30 kHz *SWT 300 ms Marker 1 [T1] -5.77 dBm 2.437820000 GHz</p> <p>30 Offset 10.5 dB</p> <p>SWP 100 dB 100</p> <p>Center 2.437 GHz 3 MHz/ Span 30 MHz</p> <p>Date: 6.APR.2023 11:19:19</p>
<p>802.11b Highest Channel</p>	<p>Ref 30 dBm *Att 25 dB *RBW 10 kHz *VSW 30 kHz *SWT 300 ms Marker 1 [T1] -7.35 dBm 2.462822500 GHz</p> <p>30 Offset 10.5 dB</p> <p>SWP 100 dB 100</p> <p>Center 2.462 GHz 3 MHz/ Span 30 MHz</p> <p>Date: 6.APR.2023 11:17:26</p>



**Maximum power spectral density**

<p>802.11g Lowest Channel</p>	<p>Ref: 30 dBm    *Att: 25 dB    *RBW: 10 kHz    Marker 1 [T1]    -8.13 dBm  *VBW: 30 kHz  SWT: 300 ms    2.408542500 GHz</p> <p>Center: 2.412 GHz    3 MHz/    Span: 30 MHz</p> <p>Date: 6.APR.2023 11:24:39</p>
<p>802.11g Middle Channel</p>	<p>Ref: 30 dBm    *Att: 25 dB    *RBW: 10 kHz    Marker 1 [T1]    -6.74 dBm  *VBW: 30 kHz  SWT: 300 ms    2.438287500 GHz</p> <p>Center: 2.437 GHz    3 MHz/    Span: 30 MHz</p> <p>Date: 6.APR.2023 11:22:38</p>
<p>802.11g Highest Channel</p>	<p>Ref: 30 dBm    *Att: 25 dB    *RBW: 10 kHz    Marker 1 [T1]    -8.70 dBm  *VBW: 30 kHz  SWT: 300 ms    2.463285000 GHz</p> <p>Center: 2.462 GHz    3 MHz/    Span: 30 MHz</p> <p>Date: 6.APR.2023 11:26:22</p>

**Maximum power spectral density**

<p>802.11n ht20 Lowest Channel</p>	<p>Ref: 30 dBm    *Att: 25 dB    *RBW: 10 kHz    Marker 1 [T1]    -10.57 dBm  *VBW: 30 kHz  SWT: 300 ms    2.418205000 GHz</p> <p>Center: 2.412 GHz    3 MHz/    Span: 30 MHz</p> <p>Date: 6.APR.2023 11:31:29</p>
<p>802.11n ht20 Middle Channel</p>	<p>Ref: 30 dBm    *Att: 25 dB    *RBW: 10 kHz    Marker 1 [T1]    -9.31 dBm  *VBW: 30 kHz  SWT: 300 ms    2.434520000 GHz</p> <p>Center: 2.437 GHz    3 MHz/    Span: 30 MHz</p> <p>Date: 6.APR.2023 11:33:54</p>
<p>802.11n ht20 Highest Channel</p>	<p>Ref: 30 dBm    *Att: 25 dB    *RBW: 10 kHz    Marker 1 [T1]    -11.03 dBm  *VBW: 30 kHz  SWT: 300 ms    2.468207500 GHz</p> <p>Center: 2.462 GHz    3 MHz/    Span: 30 MHz</p> <p>Date: 6.APR.2023 11:28:55</p>

**Maximum power spectral density**

<p>802.11n ht40 Lowest Channel</p>	<p>Ref: 30 dBm    *Att: 25 dB    *RBW: 10 kHz    Marker 1 [T1]    -12.22 dBm  *VBW: 30 kHz  SWT: 600 ms    2.415770000 GHz</p> <p>Center: 2.422 GHz    6 MHz/    Span: 60 MHz</p> <p>Date: 6.APR.2023 11:37:16</p>
<p>802.11n ht40 Middle Channel</p>	<p>Ref: 30 dBm    *Att: 25 dB    *RBW: 10 kHz    Marker 1 [T1]    -11.89 dBm  *VBW: 30 kHz  SWT: 600 ms    2.439515000 GHz</p> <p>Center: 2.437 GHz    6 MHz/    Span: 60 MHz</p> <p>Date: 6.APR.2023 11:42:08</p>
<p>802.11n ht40 Highest Channel</p>	<p>Ref: 30 dBm    *Att: 25 dB    *RBW: 10 kHz    Marker 1 [T1]    -13.30 dBm  *VBW: 30 kHz  SWT: 600 ms    2.441010000 GHz</p> <p>Center: 2.452 GHz    6 MHz/    Span: 60 MHz</p> <p>Date: 6.APR.2023 11:40:11</p>

**Maximum power spectral density**

<p>802.11ax hew20 Lowest Channel</p>	<p>Date: 7.APR.2023 14:26:17</p>
<p>802.11ax hew20 Middle Channel</p>	<p>Date: 7.APR.2023 14:24:52</p>
<p>802.11ax hew20 Highest Channel</p>	<p>Date: 7.APR.2023 14:21:58</p>

### Maximum power spectral density

<p>802.11ax hew40 Lowest Channel</p>	<p>Ref: 30 dBm    *Att: 25 dB    *RBW: 10 kHz    Marker 1 [T1]    -12.29 dBm          *VBW: 30 kHz    2.428165000 GHz          *SWT: 600 ms</p> <p>Center: 2.422 GHz    6 MHz/    Span: 60 MHz</p> <p>Date: 6.APR.2023 11:47:26</p>
<p>802.11ax hew40 Middle Channel</p>	<p>Ref: 30 dBm    *Att: 25 dB    *RBW: 10 kHz    Marker 1 [T1]    -11.36 dBm          *VBW: 30 kHz    2.444480000 GHz          *SWT: 600 ms</p> <p>Center: 2.437 GHz    6 MHz/    Span: 60 MHz</p> <p>Date: 6.APR.2023 11:44:57</p>
<p>802.11ax hew40 Highest Channel</p>	<p>Ref: 30 dBm    *Att: 25 dB    *RBW: 10 kHz    Marker 1 [T1]    -13.08 dBm          *VBW: 30 kHz    2.457210000 GHz          *SWT: 600 ms</p> <p>Center: 2.452 GHz    6 MHz/    Span: 60 MHz</p> <p>Date: 6.APR.2023 11:49:28</p>

**4.7 100 kHz Bandwidth of Frequency Band Edge:**

Serial Number:	21EC	Test Date:	2023/03/09-2023/03/10
Test Site:	RF	Test Mode:	Transmitting
Tester:	Claire Liu	Test Result:	Pass

**Environmental Conditions:**

Temperature: (°C)	24.2-25.4	Relative Humidity: (%)	37-62	ATM Pressure: (kPa)	101.8
----------------------	-----------	------------------------------	-------	------------------------	-------

**Test Equipment List and Details:**

Manufacturer	Description	Model	Serial Number	Calibration Date	Calibration Due Date
R&S	Spectrum Analyzer	FSU26	200256	2022/07/15	2023/07/14
zhuoxiang	Coaxial Cable	SMA-178	211002	Each time	N/A
eastsheep	Coaxial Attenuator	2W-SMA-JK-18G	21060302	Each time	N/A

\* Statement of Traceability: China Certification ICT Co., Ltd (Dongguan) attests that all calibrations have been performed, traceable to National Primary Standards and International System of Units (SI).

Chain 0:

100 kHz Bandwidth of Frequency Band Edge

802.11b  
Lowest Band edge

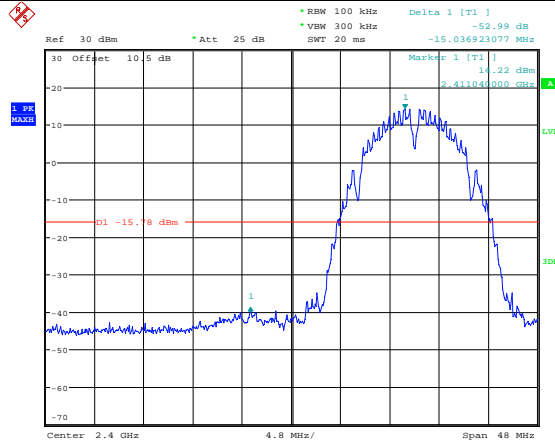

Date: 9.MAR.2023 10:11:40

802.11b  
Highest Band edge

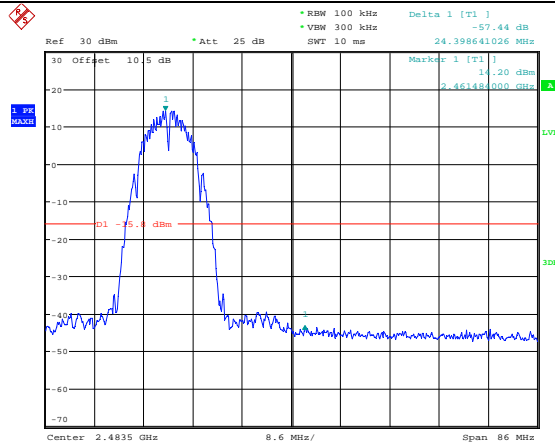

Date: 9.MAR.2023 11:33:58

**100 kHz Bandwidth of Frequency Band Edge**

802.11g  
Lowest Band edge

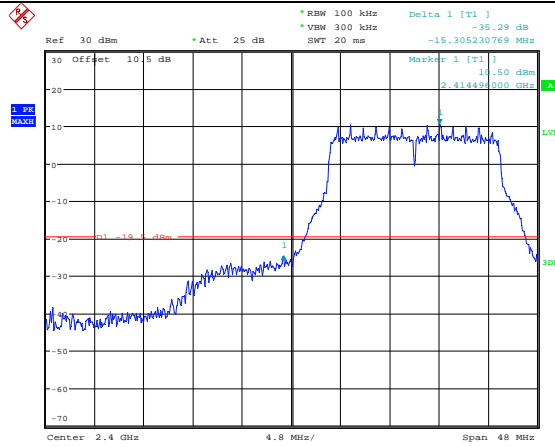

Date: 9.MAR.2023 14:55:51

802.11g  
Highest Band edge

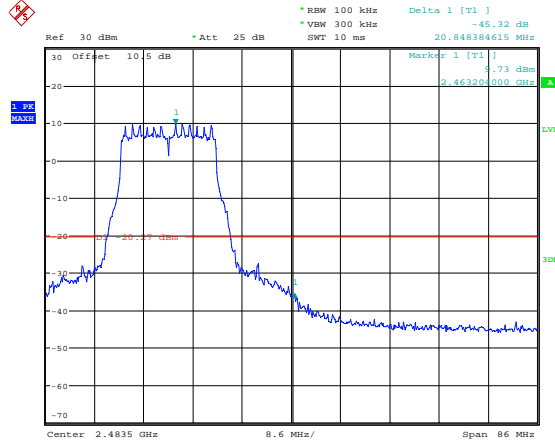

Date: 9.MAR.2023 15:26:52



**100 kHz Bandwidth of Frequency Band Edge**

802.11n ht20  
Lowest Band edge

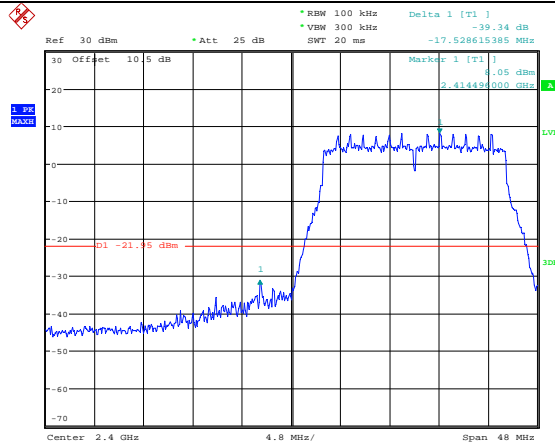

Date: 9.MAR.2023 15:42:59

802.11n ht20  
Highest Band edge

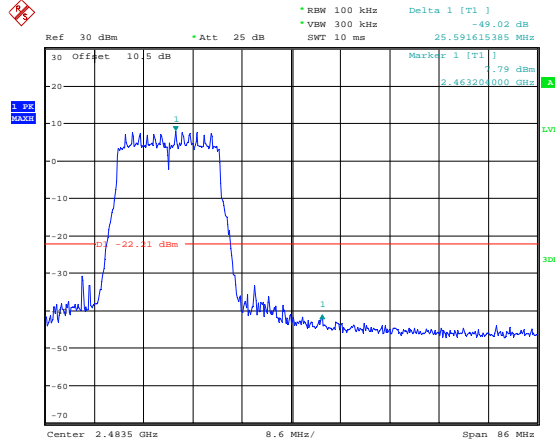

Date: 9.MAR.2023 15:33:40

### 100 kHz Bandwidth of Frequency Band Edge

802.11n ht40  
Lowest Band edge

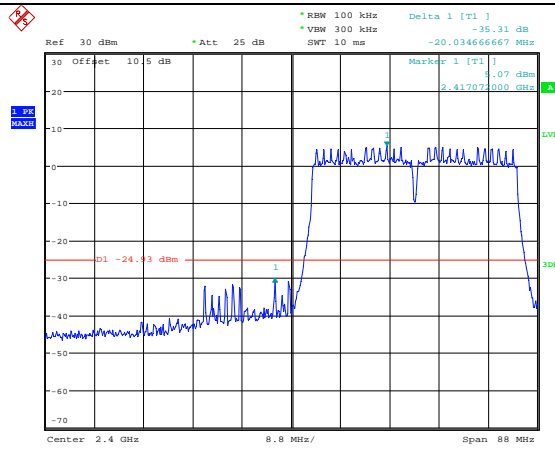

Date: 9.MAR.2023 15:49:52

802.11n ht40  
Highest Band edge

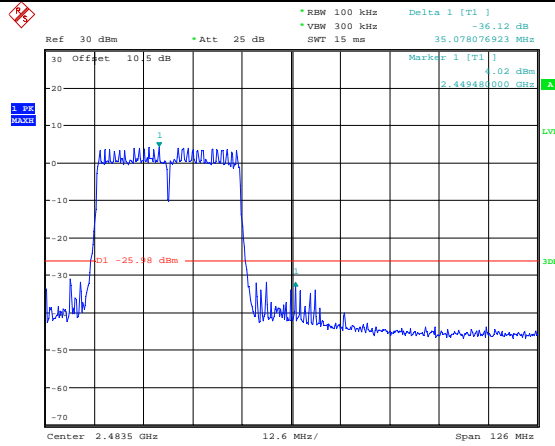

Date: 9.MAR.2023 16:02:02

### 100 kHz Bandwidth of Frequency Band Edge

802.11ax hew20  
Lowest Band edge

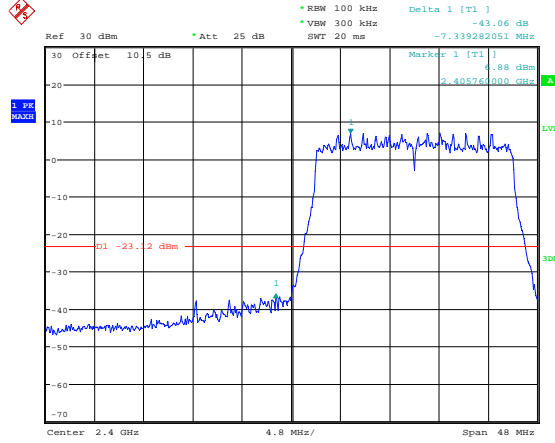

Date: 10.MAR.2023 10:22:56

802.11ax hew20  
Highest Band edge

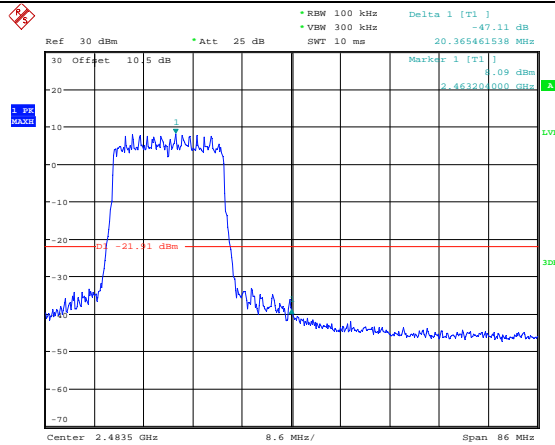

Date: 10.MAR.2023 10:35:33

**100 kHz Bandwidth of Frequency Band Edge**

802.11ax hew40  
Lowest Band edge

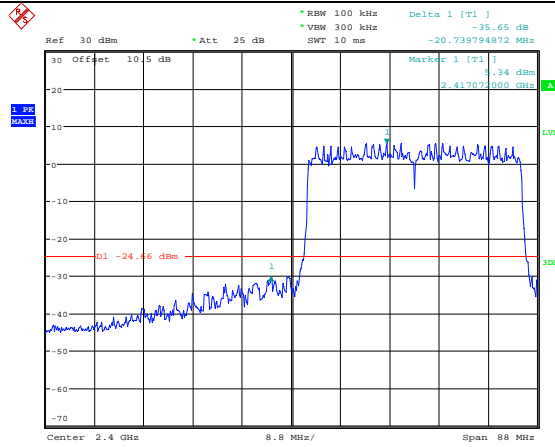

Date: 10.MAR.2023 11:17:42

802.11ax hew40  
Highest Band edge

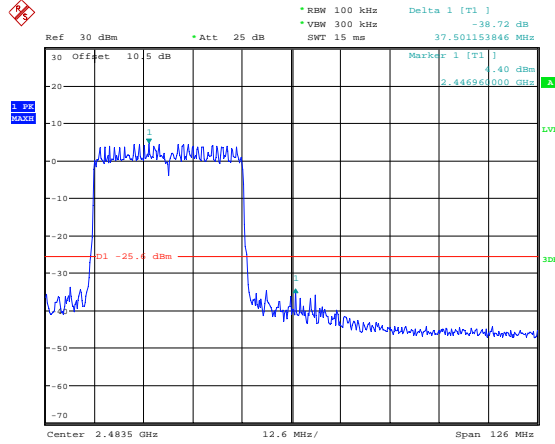

Date: 10.MAR.2023 09:45:48

Chain 1:

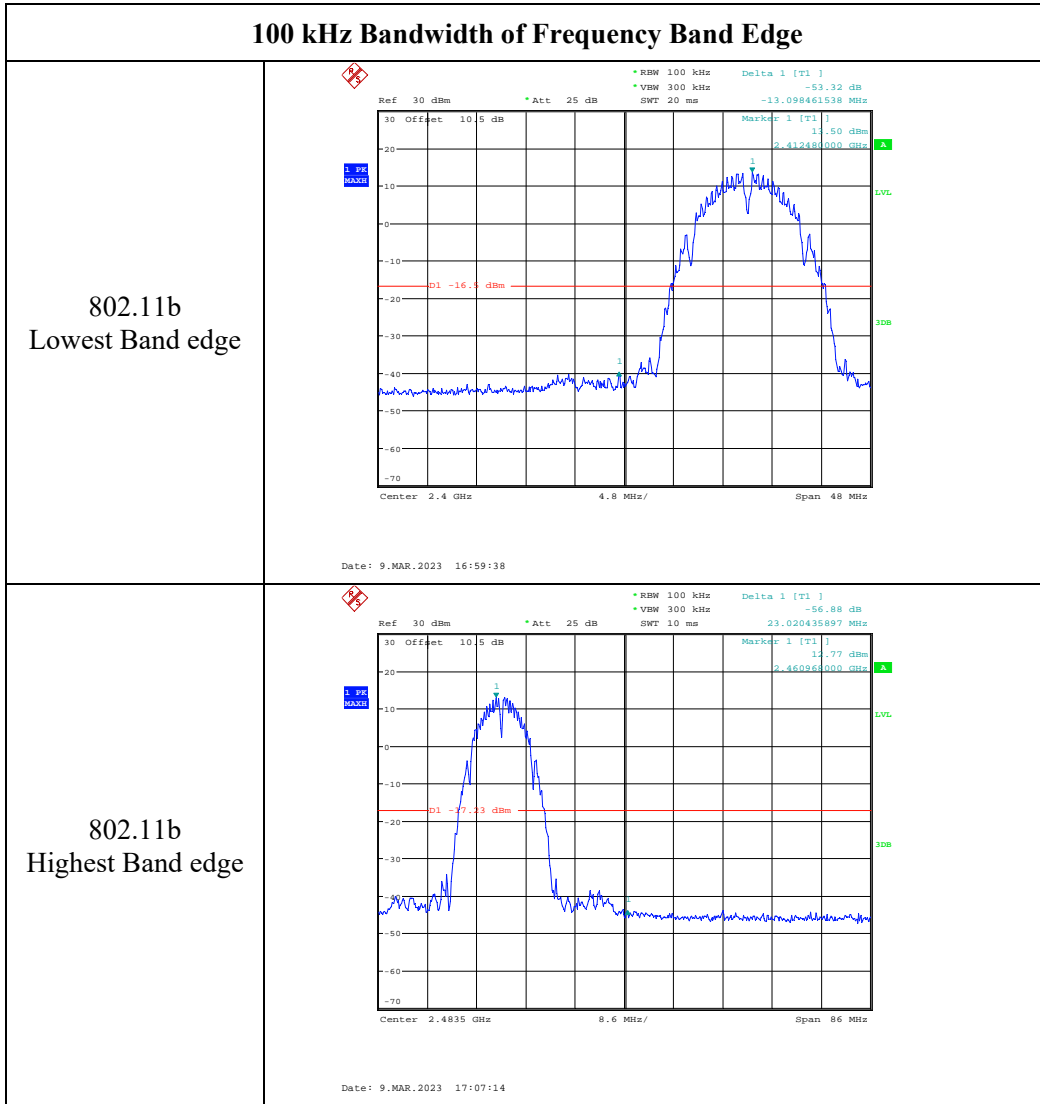

### 100 kHz Bandwidth of Frequency Band Edge

802.11g  
Lowest Band edge

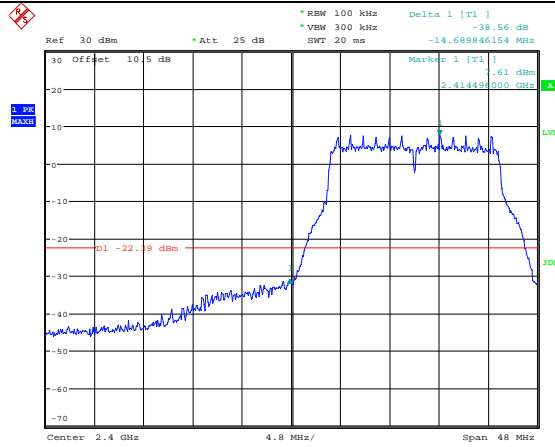

802.11g  
Highest Band edge

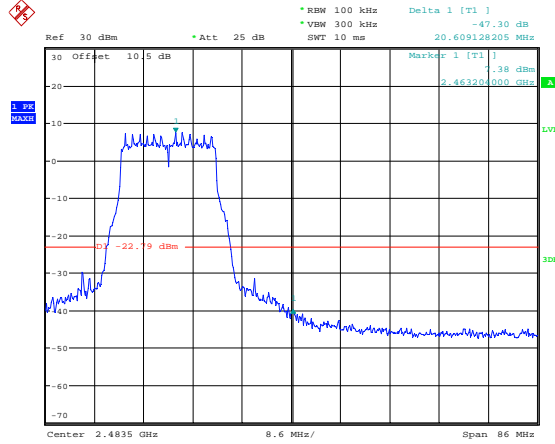

**100 kHz Bandwidth of Frequency Band Edge**

802.11n ht20  
Lowest Band edge

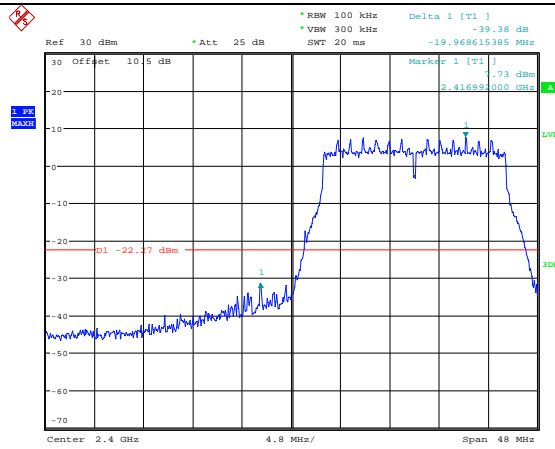

Date: 9.MAR.2023 16:40:11

802.11n ht20  
Highest Band edge

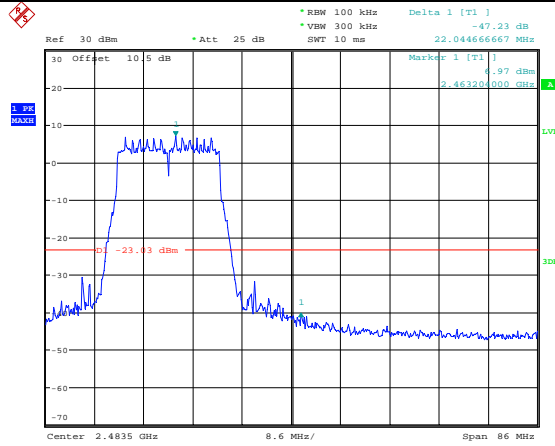

Date: 9.MAR.2023 16:45:07

### 100 kHz Bandwidth of Frequency Band Edge

802.11n ht40  
Lowest Band edge

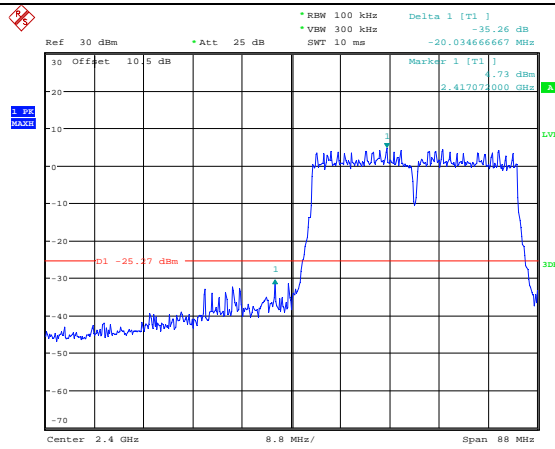

Date: 9.MAR.2023 16:12:57

802.11n ht40  
Highest Band edge

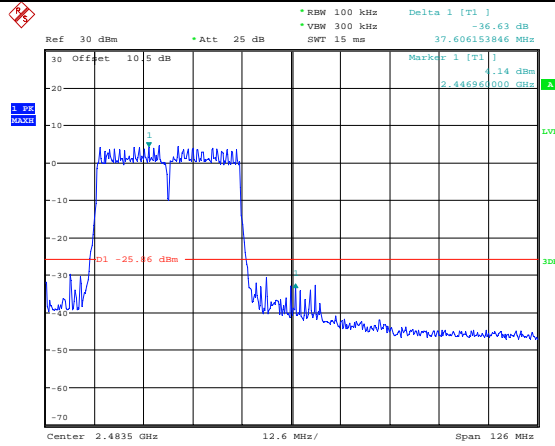

Date: 9.MAR.2023 16:37:49



**100 kHz Bandwidth of Frequency Band Edge**

802.11ax hew20  
Lowest Band edge

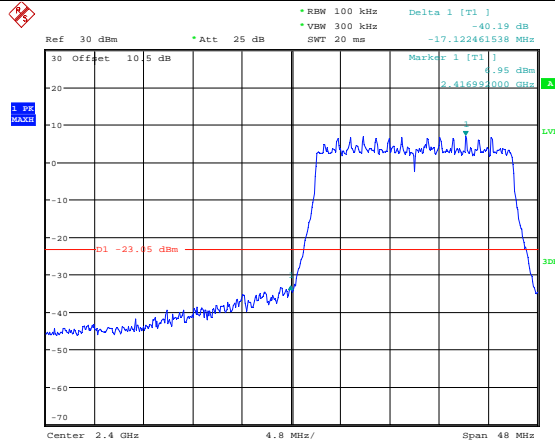

Date: 10.MAR.2023 10:48:28

802.11ax hew20  
Highest Band edge

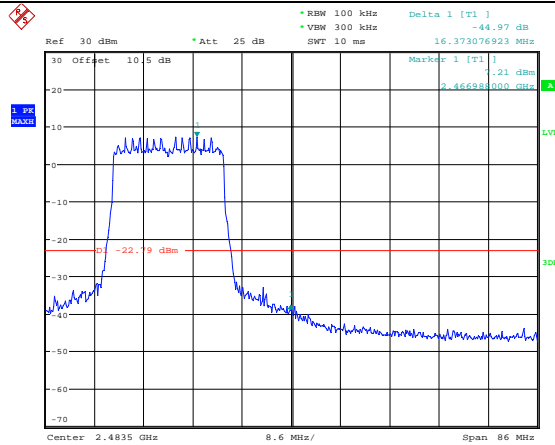

Date: 10.MAR.2023 10:38:05

### 100 kHz Bandwidth of Frequency Band Edge

802.11ax hew40  
Lowest Band edge

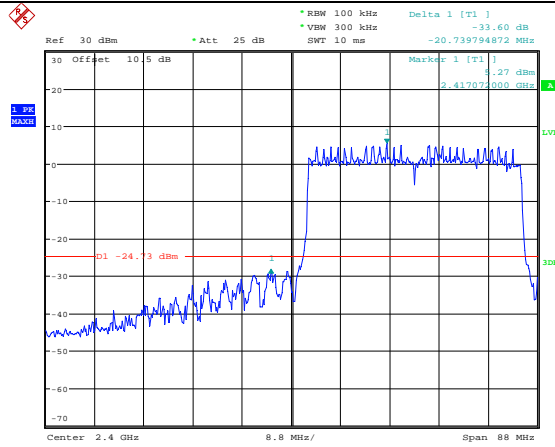

802.11ax hew40  
Highest Band edge

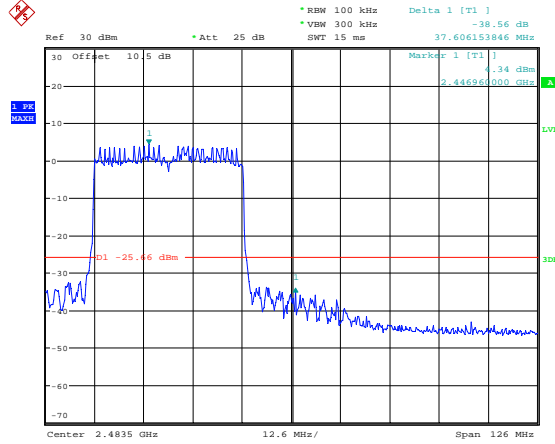

**4.8 Duty Cycle:**

Serial Number:	21EC	Test Date:	2023/03/09
Test Site:	RF	Test Mode:	Transmitting
Tester:	Claire Liu	Test Result:	N/A

**Environmental Conditions:**

Temperature: (°C)	24.8-25.4	Relative Humidity: (%)	49-62	ATM Pressure: (kPa)	101.7-102.2
----------------------	-----------	------------------------------	-------	------------------------	-------------

**Test Equipment List and Details:**

Manufacturer	Description	Model	Serial Number	Calibration Date	Calibration Due Date
R&S	Spectrum Analyzer	FSU26	200256	2022/07/15	2023/07/14
zhuoxiang	Coaxial Cable	SMA-178	211002	Each time	N/A
eastsheep	Coaxial Attenuator	2W-SMA-JK-18G	21060302	Each time	N/A

\* Statement of Traceability: China Certification ICT Co., Ltd (Dongguan) attests that all calibrations have been performed, traceable to National Primary Standards and International System of Units (SI).

**Test Data:**

Test Modes	Ton (ms)	Ton+off (ms)	Duty cycle (%)	1/T (Hz)	Duty Cycle Factor (dB)
802.11b	12.644	13.125	96.34	79	0.16
802.11g	2.126	2.208	96.29	470	0.16
802.11n ht20	1.018	1.104	92.21	982	0.35
802.11n ht40	0.512	0.604	84.77	1953	0.72
802.11ax hew20	0.811	0.826	98.18	/	/
802.11ax hew40	0.451	0.472	95.55	2217	0.20

### Duty Cycle

802.11b

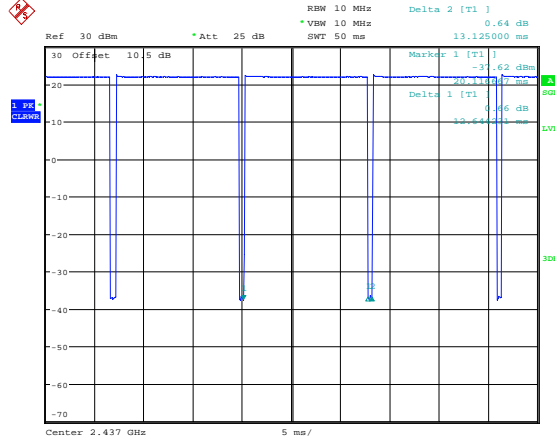

Date: 9.MAR.2023 10:17:23

802.11g

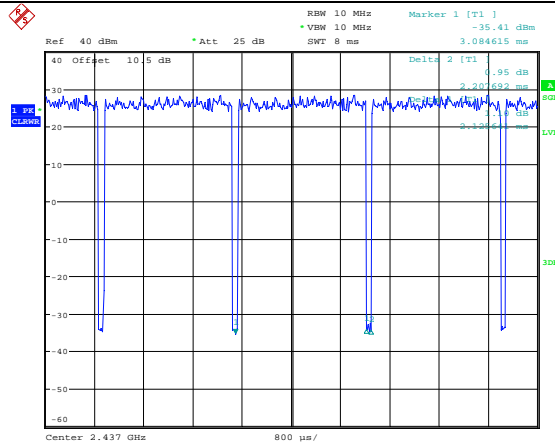

Date: 9.MAR.2023 10:20:08

802.11n ht20

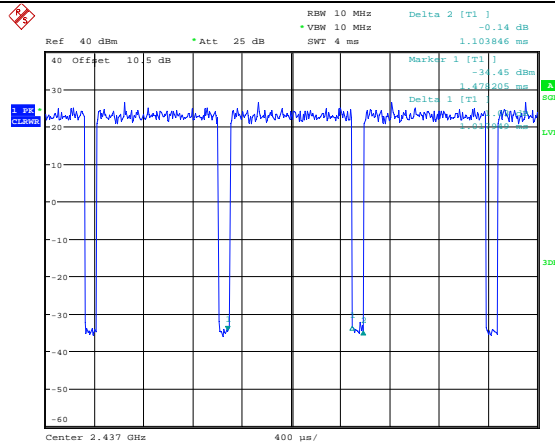

Date: 9.MAR.2023 10:22:41

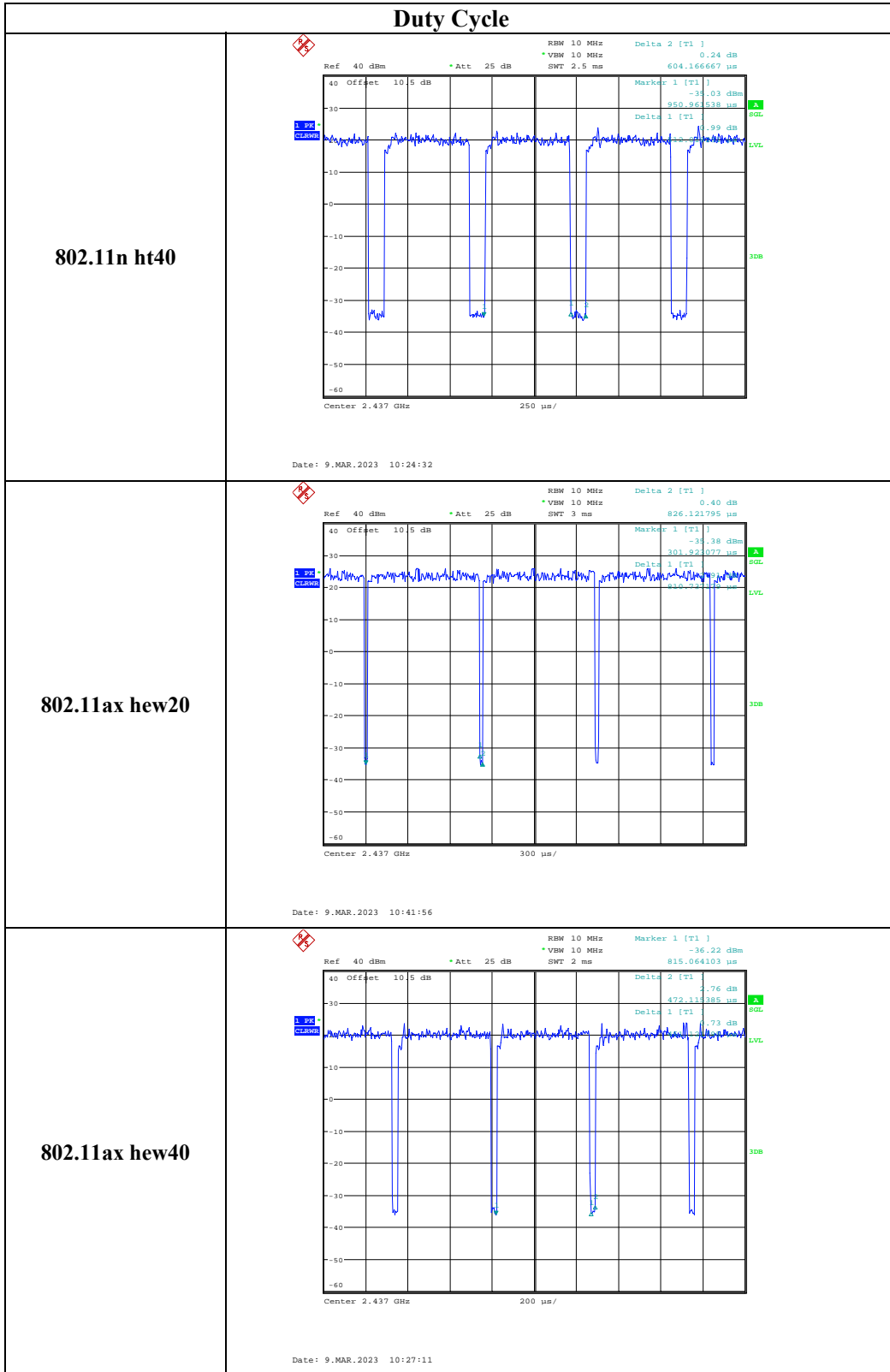

## 5. RF EXPOSURE EVALUATION

### 5.1 Applicable Standard

According to §1.1307(b)(3)(i)

(B) Or the available maximum time-averaged power or effective radiated power (ERP), whichever is greater, is less than or equal to the threshold  $P_{th}$  (mW) described in the following formula. This method shall only be used at separation distances (cm) from 0.5 centimeters to 40 centimeters and at frequencies from 0.3 GHz to 6 GHz (inclusive).  $P_{th}$  is given by:

$$P_{th} \text{ (mW)} = \begin{cases} ERP_{20 \text{ cm}} (d/20 \text{ cm})^x & d \leq 20 \text{ cm} \\ ERP_{20 \text{ cm}} & 20 \text{ cm} < d \leq 40 \text{ cm} \end{cases}$$

Where

$$x = -\log_{10} \left( \frac{60}{ERP_{20 \text{ cm}} \sqrt{f}} \right) \text{ and } f \text{ is in GHz;}$$

and

$$ERP_{20 \text{ cm}} \text{ (mW)} = \begin{cases} 2040f & 0.3 \text{ GHz} \leq f < 1.5 \text{ GHz} \\ 3060 & 1.5 \text{ GHz} \leq f \leq 6 \text{ GHz} \end{cases}$$

$d$  = the separation distance (cm);

## 5.2 Measurement Result

Operation Modes	Frequency (MHz)	Distance (mm)	P <sub>th</sub>		Maximum Conducted Power including Tune-up Tolerance (dBm)	Antenna Gain (dBi)	ERP (P) (dBm)	ERP (P) (mW)	Exemption
			(mW)	(dBm)					
WLAN 2.4G	2412-2462	200	3060	<b>34.86</b>	25	7.84	30.69	1172.20	Compliant
WLAN 5G	5150-5250	200	3060	<b>34.86</b>	22	8.93	28.78	755.09	Compliant
	5250-5350	200	3060	<b>34.86</b>	24	6.02	27.87	612.35	Compliant
	5725-5850	200	3060	<b>34.86</b>	25	8.34	31.19	1315.22	Compliant

Note:

Antenna gain includes beamforming gain for WLAN 2.4G and 5150-5250MHz/5725-5850MHz(the maximum power at 802.11a mode for 5250-5350MHz band was used for RF exposure evaluation). The Maximum Conducted Power including Tune-up Tolerance was declared by manufacturer.

WLAN 2.4G and 5G can transmit simultaneously.

$$\sum_{i=1}^a \left( \frac{P_i}{P_{th\_i}} \right) + \sum_{j=1}^b \left( \frac{ERP_j}{ERP_{th\_j}} \right) + \sum_{k=1}^c \left( \frac{Evaluated_k}{Exposure Limit_k} \right)$$

$$= P_{-2.4G}/P_{th-2.4G} + P_{-5G}/P_{th-5G}$$

$$= 1172.20/3060 + 1315.22/3060$$

$$= 0.81$$

**Result: The device compliant the Exemption at 20cm distances.**

**===== END OF REPORT =====**