

FCC Radio Test Report

FCC ID: V7TMESH3-18

This report concerns (check one): Original Grant Class I Change Class II Change

Project No. : 1804C051
Equipment : Whole Home Mesh WiFi System
Test Model : Mesh3
Series Model : MW6
Applicant : SHENZHEN TENDA TECHNOLOGY CO.,LTD
Address : 6-8 Floor, Tower E3, No. 1001, Zhongshanyuan Road, Nanshan District, Shenzhen, China. 518052

Date of Receipt : Apr. 11, 2018
Date of Test : Apr. 13, 2018 ~ Apr. 27, 2018
Issued Date : May. 07, 2018
Tested by : BTL Inc.

Testing Engineer : Welly Zhou
(Welly Zhou)

Technical Manager : Shawn Xiao
(Shawn Xiao)

Authorized Signatory : David Mao
(David Mao)

B T L I N C .

No.3, Jinshagang 1st Road, Shixia, Dalang Town, Dongguan, Guangdong, China.

TEL: +86-769-8318-3000 FAX: +86-769-8319-6000



Declaration

BTL represents to the client that testing is done in accordance with standard procedures as applicable and that test instruments used has been calibrated with standards traceable to international standard(s) and/or national standard(s).

BTL's reports apply only to the specific samples tested under conditions. It is manufacture's responsibility to ensure that additional production units of this model are manufactured with the identical electrical and mechanical components. **BTL** shall have no liability for any declarations, inferences or generalizations drawn by the client or others from **BTL** issued reports.

BTL's report must not be used by the client to claim product certification, approval, or endorsement by NVLAP, NIST, or any agency of the Federal Government.

This report is the confidential property of the client. As a mutual protection to the clients, the public and **BTL-self**, extracts from the test report shall not be reproduced except in full with **BTL's** authorized written approval.

BTL's laboratory quality assurance procedures are in compliance with the **ISO Guide 17025** requirements, and accredited by the conformity assessment authorities listed in this test report.

Limitation

For the use of the authority's logo is limited unless the Test Standard(s)/Scope(s)/Item(s) mentioned in this test report is (are) included in the conformity assessment authorities acceptance respective.

Table of Contents

Page

1 . CERTIFICATION	6
2 . SUMMARY OF TEST RESULTS	7
2.1 TEST FACILITY	8
2.2 MEASUREMENT UNCERTAINTY	8
3 . GENERAL INFORMATION	9
3.1 GENERAL DESCRIPTION OF EUT	9
3.2 DESCRIPTION OF TEST MODES	12
3.3 TABLE OF PARAMETERS OF TEST SOFTWARE SETTING	14
3.4 BLOCK DIAGRAM SHOWING THE CONFIGURATION OF SYSTEM TESTED	16
3.5 DESCRIPTION OF SUPPORT UNITS	16
4 . EMC EMISSION TEST	17
4.1 CONDUCTED EMISSION MEASUREMENT	17
4.1.1 POWER LINE CONDUCTED EMISSION	17
4.1.2 TEST PROCEDURE	17
4.1.3 DEVIATION FROM TEST STANDARD	17
4.1.4 TEST SETUP	18
4.1.5 EUT OPERATING CONDITIONS	18
4.1.6 EUT TEST CONDITIONS	18
4.1.7 TEST RESULTS	18
4.2 RADIATED EMISSION MEASUREMENT	19
4.2.1 RADIATED EMISSION LIMITS	19
4.2.2 TEST PROCEDURE	20
4.2.3 DEVIATION FROM TEST STANDARD	20
4.2.4 TEST SETUP	21
4.2.5 EUT OPERATING CONDITIONS	22
4.2.6 EUT TEST CONDITIONS	22
4.2.7 TEST RESULTS (9K TO 30MHz)	23
4.2.8 TEST RESULTS (BETWEEN 30 TO 1000 MHz)	23
4.2.9 TEST RESULTS (ABOVE 1000 MHz)	23
5 . 26dB SPECTRUM BANDWIDTH	24
5.1 APPLIED PROCEDURES / LIMIT	24
5.1.1 TEST PROCEDURE	24
5.1.2 DEVIATION FROM STANDARD	24
5.1.3 TEST SETUP	24
5.1.4 EUT OPERATION CONDITIONS	24
5.1.5 EUT TEST CONDITIONS	25
5.1.6 TEST RESULTS	25
6 . MAXIMUM CONDUCTED OUTPUT POWER	26

Table of Contents	Page
6.1 APPLIED PROCEDURES / LIMIT	26
6.1.1 TEST PROCEDURE	26
6.1.2 DEVIATION FROM STANDARD	27
6.1.3 TEST SETUP	27
6.1.4 EUT OPERATION CONDITIONS	27
6.1.5 EUT TEST CONDITIONS	27
6.1.6 TEST RESULTS	27
7 . POWER SPECTRAL DENSITY TEST	28
7.1 APPLIED PROCEDURES / LIMIT	28
8.1.1 TEST PROCEDURE	28
7.1.1 DEVIATION FROM STANDARD	29
7.1.2 TEST SETUP	29
7.1.3 EUT OPERATION CONDITIONS	29
7.1.4 EUT TEST CONDITIONS	29
7.1.5 TEST RESULTS	29
8 . FREQUENCY STABILITY MEASUREMENT	30
8.1 APPLIED PROCEDURES / LIMIT	30
8.1.1 TEST PROCEDURE	30
8.1.2 DEVIATION FROM STANDARD	30
8.1.3 TEST SETUP	31
8.1.4 EUT OPERATION CONDITIONS	31
8.1.5 EUT TEST CONDITIONS	31
8.1.6 TEST RESULTS	31
9 . MEASUREMENT INSTRUMENTS LIST	32
10 . EUT TEST PHOTOS	34
APPENDIX A - CONDUCTED EMISSION	38
APPENDIX B - RADIATED EMISSION (9KHZ TO 30MHZ)	41
APPENDIX C - RADIATED EMISSION (30MHZ TO 1000MHZ)	46
APPENDIX D - RADIATED EMISSION (ABOVE 1000MHZ)	59
APPENDIX E - BANDWIDTH	178
APPENDIX F - MAXIMUM OUTPUT POWER	219
APPENDIX G - POWER SPECTRAL DENSITY	240
APPENDIX H - FREQUENCY STABILITY	337

REPORT ISSUED HISTORY

Issued No.	Description	Issued Date
BTL-FCCP-2-1804C051	Original Issue.	May. 07, 2018

1. CERTIFICATION

Equipment : Whole Home Mesh WiFi System
Brand Name : Tenda
Test Model : Mesh3
Series Model : MW6
Applicant : SHENZHEN TENDA TECHNOLOGY CO.,LTD
Manufacturer : SHENZHEN TENDA TECHNOLOGY CO.,LTD
Address : 6-8 Floor, Tower E3, No. 1001, Zhongshanyuan Road, Nanshan District,
Shenzhen, China. 518052
Date of Test : Apr. 13, 2018 ~ Apr. 27, 2018
Test Sample : Engineering Sample NO.: D180403018
Standard(s) : FCC Part15, Subpart E(15.407) / ANSI C63.10-2013

The above equipment has been tested and found compliance with the requirement of the relative standards by BTL Inc.

The test data, data evaluation, and equipment configuration contained in our test report (Ref No. BTL-FCCP-2-1804C051) were obtained utilizing the test procedures, test instruments, test sites that has been accredited by the Authority of NVLAP according to the ISO-17025 quality assessment standard and technical standard(s).

2. SUMMARY OF TEST RESULTS

Test procedures according to the technical standard(s):

FCC Part15, Subpart E(15.407)			
Standard(s) Section	Test Item	Judgment	Remark
15.207	AC Power Line Conducted Emissions	PASS	
15.407(a)	26dB Spectrum Bandwidth	PASS	
15.407(a)	Maximum Conducted Output Power	PASS	
15.407(a)	Power Spectral Density	PASS	
15.407(a)	Radiated Emissions	PASS	
15.407(b)	Band Edge Emissions	PASS	
15.407(g)	Frequency Stability	PASS	
15.203	Antenna Requirements	PASS	

NOTE:

(1) "N/A" denotes test is not applicable in this test report.

2.1 TEST FACILITY

The test facilities used to collect the test data in this report is at the location of No.3,Jinshagang 1st Road, Shixia, Dalang Town, Dongguan, Guangdong, China.

BTL's test firm number for FCC: 854385

Designation number for FCC: CN5020

2.2 MEASUREMENT UNCERTAINTY

The measurement uncertainty figures shall be calculated according the methods described in the ETSI TR 100 028 and shall correspond to an expansion factor (coverage factor) $k=1.96$ or $k=2$ (which provide confidence levels of respectively 90% and 95.45% in the case where the distributions characterizing the actual measurement uncertainties are normal (Gaussian)). Measurement Uncertainty for a Level of Confidence of 95 %, $U=2xUc(y)$.

The BTL measurement uncertainty as below table:

A. Conducted Measurement:

Test Site	Method	Measurement Frequency Range	U, (dB)
DG-C02	CISPR	150 KHz ~ 30MHz	2.32

B. Radiated Measurement:

Test Site	Method	Measurement Frequency Range	Ant. H / V	U, (dB)
DG-CB03	CISPR	9kHz~30MHz	V	3.79
		9kHz~30MHz	H	3.57
		30MHz ~ 200MHz	V	3.82
		30MHz ~ 200MHz	H	3.60
		200MHz ~ 1,000MHz	V	3.86
		200MHz ~ 1,000MHz	H	3.94
		1GHz~18GHz	V	3.12
		1GHz~18GHz	H	3.68
		18GHz~40GHz	V	4.15
		18GHz~40GHz	H	4.14

Note: Unless specifically mentioned, the uncertainty of measurement has not been taken into account to declare the compliance or non-compliance to the specification.

3. GENERAL INFORMATION

3.1 GENERAL DESCRIPTION OF EUT

Equipment	Whole Home Mesh WiFi System	
Brand Name	Tenda	
Test Model	Mesh3	
Series Model	MW6	
Mode Different	Only difference in model number.	
Product Description	Operation Frequency	UNII-1: 5150-5250MHz UNII-3: 5725-5850MHz
	Modulation Type	802.11a:OFDM 802.11n:OFDM 802.11ac:OFDM
	Bit Rate of Transmitter	802.11a: 54/48/36/24/18/12/9/6 Mbps 802.11n: up to 300 Mbps 802.11ac: up to 867 Mbps
Power Source	DC Voltage supplied from AC/DC adapter. Model: BN071-A12012U	
Power Rating	I/P: 100-240V~ 50/60Hz 0.4A O/P: 12V 1A	
Product Description	Output Power (Max.) for UNII-1 Non Beamforming	802.11a: 27.33dBm 802.11n (20M): 27.77dBm 802.11n (40M): 27.51dBm 802.11ac (20M): 27.54dBm 802.11ac (40M): 27.60dBm 802.11ac (80M): 20.61dBm
	Output Power (Max.)for UNII-3 Non Beamforming	802.11a: 27.59dBm 802.11n (20M): 27.79dBm 802.11n (40M): 27.65dBm 802.11ac (20M): 27.64dBm 802.11ac (40M): 27.80dBm 802.11ac (80M): 25.50dBm
	Output Power (Max.)for UNII-1 Beamforming	802.11n (20M): 27.40dBm 802.11n (40M): 27.09dBm 802.11ac (20M): 27.22dBm 802.11ac (40M): 27.19dBm 802.11ac (80M): 20.29dBm
	Output Power (Max.)for UNII-3 Beamforming	802.11n (20M): 27.45dBm 802.11n (40M): 27.27dBm 802.11ac (20M): 27.22dBm 802.11ac (40M): 27.38dBm 802.11ac (80M): 25.09dBm

Note:

1. For a more detailed features description, please refer to the manufacturer's specifications or the User's Manual.
2. Channel List:

802.11a 802.11n 20MHz 802.11ac 20MHz		802.11n 40MHz 802.11ac 40MHz		802.11ac 80MHz	
Channel	Frequency (MHz)	Channel	Frequency (MHz)	Channel	Frequency (MHz)
36	5180	38	5190	42	5210
40	5200	46	5230		
44	5220				
48	5240				

802.11a 802.11n 20MHz 802.11ac 20MHz		802.11n 40MHz 802.11ac 40MHz		802.11ac 80MHz	
Channel	Frequency (MHz)	Channel	Frequency (MHz)	Channel	Frequency (MHz)
149	5745	151	5755	155	5775
153	5765	159	5795		
157	5785				
161	5805				
165	5825				

3. Antenna Specification:

Ant.	Manufacturer	Model Name	Antenna Type	Connector	Gain (dBi)	Note
1	N/A	N/A	Internal	N/A	3	N/A
2	N/A	N/A	Internal	N/A	3	N/A

Note:

(1) Antenna Gain=3 dBi. This EUT supports MIMO 2X2, any transmit signals are correlated with each other, so Directional gain = $G_{ANT} + 10 \log(N)$ dBi, that is Directional gain = $3 + 10 \log(2)$ dBi = 6.01; So the UNII-1, UNII-3 output power limit is $30 - 6.01 + 6 = 29.99$. The UNII-1 power density limit is $17 - 6.01 + 6 = 16.99$, the UNII-3 power density limit is $30 - 6.01 + 6 = 29.99$.

(2) Beamforming Gain: 3 dBi, So Direction gain = $3 + 3 = 6$.

4. Operating Mode

TX Mode	1TX	2TX
802.11a	V (ANT 1)	-
802.11n (20MHz)	-	V (ANT 1+ANT 2)
802.11n (40MHz)	-	V (ANT 1+ANT 2)
802.11ac (20MHz)	-	V (ANT 1+ANT 2)
802.11ac (40MHz)	-	V (ANT 1+ANT 2)
802.11ac (80MHz)	-	V (ANT 1+ANT 2)

ANT 1 for 1TX was found to be the worst case and recorded

3.2 DESCRIPTION OF TEST MODES

To investigate the maximum EMI emission characteristics generates from EUT, the test system was pre-scanning tested base on the consideration of following EUT operation mode or test configuration mode which possible have effect on EMI emission level. Each of these EUT operation mode(s) or test configuration mode(s) mentioned above was evaluated respectively.

Pretest Mode	Description
Mode 1	TX A Mode / CH36, CH40, CH48 (UNII-1)
Mode 2	TX N20 Mode / CH36, CH40, CH48 (UNII-1)
Mode 3	TX N40 Mode / CH38, CH46 (UNII-1)
Mode 4	TX AC20 Mode / CH36, CH40, CH48 (UNII-1)
Mode 5	TX AC40 Mode / CH38, CH46 (UNII-1)
Mode 6	TX AC80 Mode / CH42 (UNII-1)
Mode 7	TX A Mode / CH149,CH157,CH165 (UNII-3)
Mode 8	TX N20 Mode / CH149,CH157,CH165 (UNII-3)
Mode 9	TX N40 Mode / CH151,CH159 (UNII-3)
Mode 10	TX AC20 Mode / CH149,CH157,CH165 (UNII-3)
Mode 11	TX AC40 Mode / CH151,CH159 (UNII-3)
Mode 12	TX AC80 Mode / CH155 (UNII-3)
Mode 13	TX Mode

The EUT system operated these modes were found to be the worst case during the pre-scanning test as following:

For Conducted Test	
Final Test Mode	Description
Mode 13	TX Mode

For Radiated Test	
Final Test Mode	Description
Mode 1	TX A Mode / CH36, CH40, CH48 (UNII-1)
Mode 2	TX N20 Mode / CH36, CH40, CH48 (UNII-1)
Mode 3	TX N40 Mode / CH38, CH46 (UNII-1)
Mode 4	TX AC20 Mode / CH36, CH40, CH48 (UNII-1)
Mode 5	TX AC40 Mode / CH38, CH46 (UNII-1)
Mode 6	TX AC80 Mode / CH42 (UNII-1)
Mode 7	TX A Mode / CH149,CH157,CH165 (UNII-3)
Mode 8	TX N20 Mode / CH149,CH157,CH165 (UNII-3)
Mode 9	TX N40 Mode / CH151,CH159 (UNII-3)
Mode 10	TX AC20 Mode / CH149,CH157,CH165 (UNII-3)
Mode 11	TX AC40 Mode / CH151,CH159 (UNII-3)
Mode 12	TX AC80 Mode / CH155 (UNII-3)

Note:

(1) For radiated below 1GHz test, the 802.11a mode is found to be the worst case and recorded.

3.3 TABLE OF PARAMETERS OF TEST SOFTWARE SETTING

During testing channel & power controlling software provided by the customer was used to control the operating channel as well as the output power level. The RF output power selection is for the setting of RF output power expected by the customer and is going to be fixed on the firmware of the final end product

Non Beamforming

UNII-1			
Test Software Version	MP_TEST		
Frequency (MHz)	5180	5200	5240
A Mode	47	61	61
N20 Mode	45/48	49/52	49/52
AC20 Mode	45/48	49/52	49/51
Frequency (MHz)	5190	5230	
N40 Mode	41/43	49/52	
AC40 Mode	40/42	49/50	
Frequency (MHz)	5210		
AC80 Mode	34/37		

UNII-3			
Test Software Version	MP_TEST		
Frequency (MHz)	5745	5785	5825
A Mode	57	56	57
N20 Mode	46/42	46/42	45/41
AC20 Mode	46/42	46/42	45/41
Frequency (MHz)	5755	5795	
N40 Mode	49/43	48/43	
AC40 Mode	49/43	48/43	
Frequency (MHz)	5775		
AC80 Mode	48/43		

Beamforming

UNII-1			
Test Software Version	MP_TEST		
Frequency (MHz)	5180	5200	5240
N20 Mode	45/48	49/52	49/52
AC20 Mode	45/48	49/52	49/51
Frequency (MHz)	5190	5230	/
N40 Mode	41/43	49/52	/
AC40 Mode	40/42	49/50	/
Frequency (MHz)	5210	/	/
AC80 Mode	34/37	/	/

UNII-3			
Test Software Version	MP_TEST		
Frequency (MHz)	5745	5785	5825
N20 Mode	46/42	46/42	45/41
AC20 Mode	46/42	46/42	45/41
Frequency (MHz)	5755	5795	/
N40 Mode	49/43	48/43	/
AC40 Mode	49/43	48/43	/
Frequency (MHz)	5775	/	/
AC80 Mode	48/43	/	/

3.4 BLOCK DIAGRAM SHOWING THE CONFIGURATION OF SYSTEM TESTED

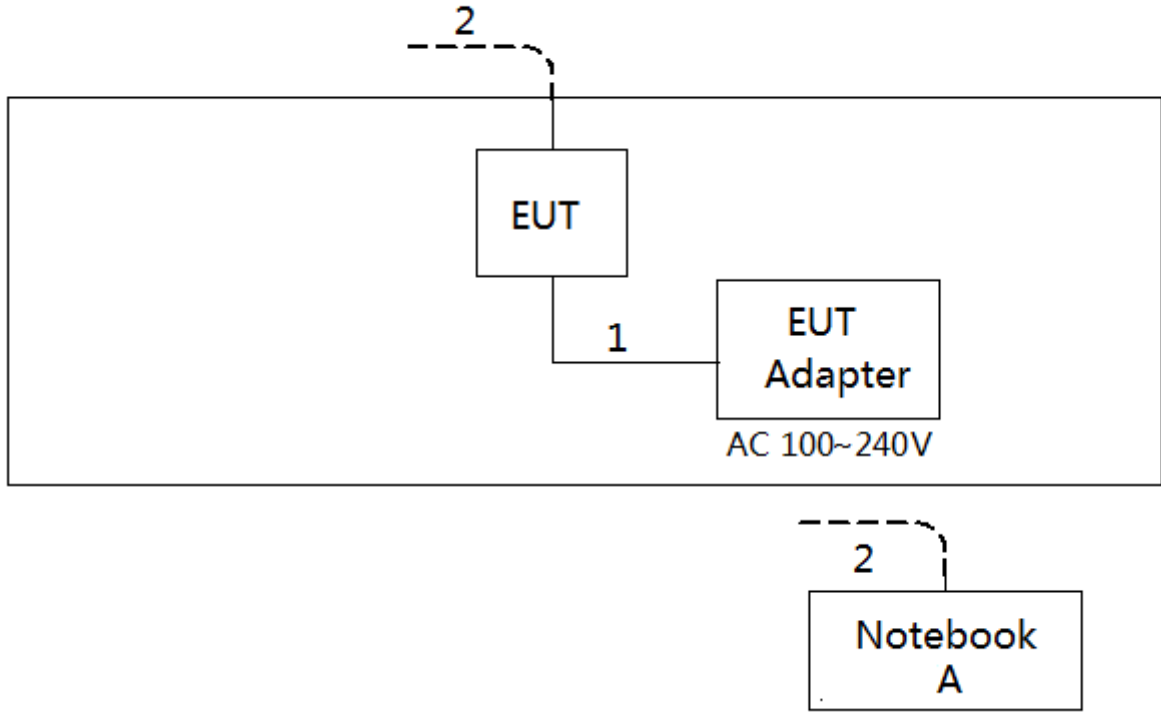

3.5 DESCRIPTION OF SUPPORT UNITS

The EUT has been tested as an independent unit together with other necessary accessories or support units. The following support units or accessories were used to form a representative test configuration during the tests.

Item	Equipment	Mfr/Brand	Model/Type No.	FCC ID	Series No.
A	Notebook	Lenovo	INSPIRON 1420	DOC	JX193A01SDC2

Item	Shielded Type	Ferrite Core	Length	Note
1	NO	NO	1.2M	DC Cable
2	NO	NO	10M	RJ45 Cable

4. EMC EMISSION TEST

4.1 CONDUCTED EMISSION MEASUREMENT

4.1.1 POWER LINE CONDUCTED EMISSION (Frequency Range 150kHz-30MHz)

FREQUENCY (MHz)	Class A (dBuV)		Class B (dBuV)	
	Quasi-peak	Average	Quasi-peak	Average
0.15 -0.5	79.00	66.00	66 - 56 *	56 - 46 *
0.50 -5.0	73.00	60.00	56.00	46.00
5.0 -30.0	73.00	60.00	60.00	50.00

Note:

- (1) The tighter limit applies at the band edges.
- (2) The limit of " * " marked band means the limitation decreases linearly with the logarithm of the frequency in the range.

4.1.2 TEST PROCEDURE

- a. The EUT was placed 0.8 meters from the horizontal ground plane with EUT being connected to the power mains through a line impedance stabilization network (LISN). All other support equipments powered from additional LISN(s). The LISN provide 50 Ohm/ 50uH of coupling impedance for the measuring instrument.
- b. Interconnecting cables that hang closer than 40 cm to the ground plane shall be folded back and forth in the center forming a bundle 30 to 40 cm long.
- c. I/O cables that are not connected to a peripheral shall be bundled in the center. The end of the cable may be terminated, if required, using the correct terminating impedance. The overall length shall not exceed 1 m.
- d. LISN at least 80 cm from nearest part of EUT chassis.
- e. For the actual test configuration, please refer to the related Item –EUT Test Photos.

4.1.3 DEVIATION FROM TEST STANDARD

No deviation

4.1.4 TEST SETUP

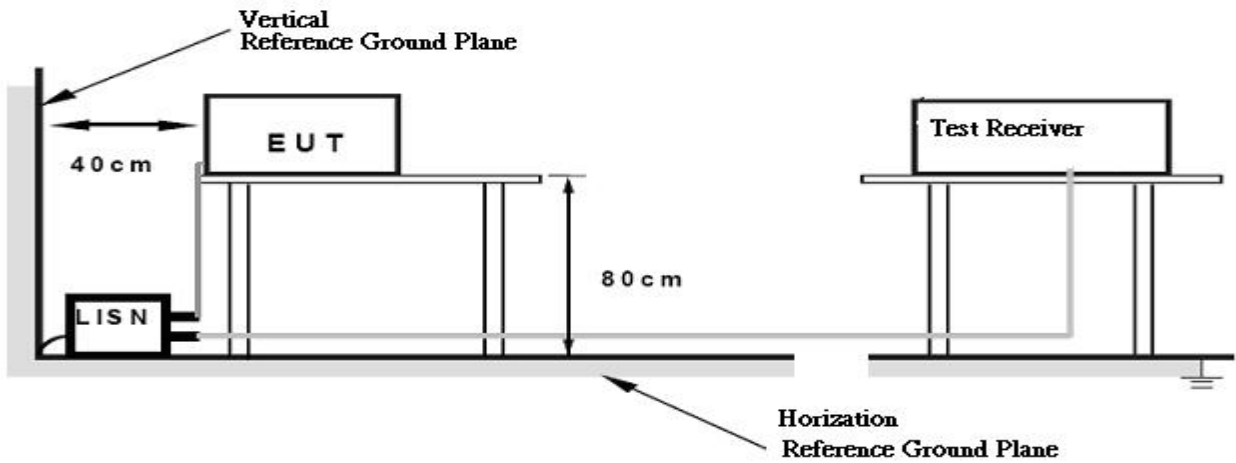

4.1.5 EUT OPERATING CONDITIONS

The EUT was configured for testing in a typical fashion (as a customer would normally use it). The EUT has been programmed to continuously transmit during test. This operating condition was tested and used to collect the included data.

The EUT was programmed to be in continuously transmitting/TX Mode mode.

4.1.6 EUT TEST CONDITIONS

Temperature: 25°C Relative Humidity: 53% Test Voltage: AC 120V/60Hz

4.1.7 TEST RESULTS

Please refer to the Appendix A.

Remark:

- (1) All readings are QP Mode value unless otherwise stated AVG in column of『Note』. If the QP Mode Measured value compliance with the QP Limits and lower than AVG Limits, the EUT shall be deemed to meet both QP & AVG Limits and then only QP Mode was measured, but AVG Mode didn't perform. In this case, a “ * ” marked in AVG Mode column of Interference Voltage Measured.
- (2) Measuring frequency range from 150kHz to 30MHz.

4.2 RADIATED EMISSION MEASUREMENT

4.2.1 RADIATED EMISSION LIMITS

In case the emission fall within the restricted band specified on 15.205(a), then the 15.209(a) limit in the table below has to be followed.

Frequencies (MHz)	Field Strength (microrvolts/meter)	Measurement Distance (meters)
0.009~0.490	2400/F(kHz)	300
0.490~1.705	24000/F(kHz)	30
1.705~30.0	30	30
30~88	100	3
88~216	150	3
216~960	200	3
Above 960	500	3

Frequencies (MHz)	EIRP Limit (dBm)	Equivalent Field Strength at 3m (dBμV/m)
5150-5250	-27	68.3
5250-5350	-27	68.3
5470-5725	-27	68.3
5725-5850	-27(Note 2)	68.3
	10(Note 2)	105.3
	15.6(Note 2)	110.9
	27(Note 2)	122.3

Note:

1. The following formula is used to convert the equipment isotropic radiated power (eirp) to

field strength: $E = \frac{1000000\sqrt{30P}}{3}$ μV/m, where P is the eirp (Watts)

2. According to FCC 16-24, All emissions shall be limited to a level of -27 dBm/MHz at 75 MHz or more above or below the band edge increasing linearly to 10 dBm/MHz at 25 MHz above or below the band edge, and from 25MHz above or below the band edge increasing linearly to a level of 15.6 dBm/MHz at 5 MHz above or below the band edge, and from 5 MHz above or below the band edge increasing linearly to a level of 27dBm/MHz at the band edge.

4.2.2 TEST PROCEDURE

- a. The measuring distance of 3 m shall be used for measurements. The EUT was placed on the top of a rotating table 0.8 meter above the ground at a 3 meter semi-anechoic chamber. The table was rotated 360 degrees to determine the position of the highest radiation.(below 1GHz)
- b. The measuring distance of 3 m shall be used for measurements. The EUT was placed on the top of a rotating table 1.5 meter above the ground at a 3 meter semi-anechoic chamber. The table was rotated 360 degrees to determine the position of the highest radiation.(above 1GHz)
- c. The height of the equipment or of the substitution antenna shall be 0.8m or 1.5m; the height of the test antenna shall vary between 1 m to 4 m. Both horizontal and vertical polarizations of the antenna are set to make the measurement.
- d. For each suspected emission, the EUT was arranged to its worst case and then the antenna was tuned to heights find the maximum reading (used Bore sight function).
- e. The receiver system was set to peak and average detect function and specified bandwidth with maximum hold mode when the test frequency is above 1GHz.
- f. The initial step in collecting radiated emission data is a receiver peak detector mode pre-scanning the measurement frequency range. Significant peaks are then marked and then Quasi Peak detector mode re-measured.
- g. All readings are Peak unless otherwise stated QP in column of Note. Peak denotes that the Peak reading compliance with the QP Limits and then QP Mode measurement didn't perform. (below 1GHz)
- h. All readings are Peak Mode value unless otherwise stated AVG in column of Note. If the Peak Mode Measured value compliance with the Peak Limits and lower than AVG Limits, the EUT shall be deemed to meet both Peak & AVG Limits and then only Peak Mode was measured, but AVG Mode didn't perform. (above 1GHz)
- i. For the actual test configuration, please refer to the related Item –EUT Test Photos.

4.2.3 DEVIATION FROM TEST STANDARD

No deviation

4.2.4 TEST SETUP

(A) Radiated Emission Test Set-Up Frequency Below 1GHz

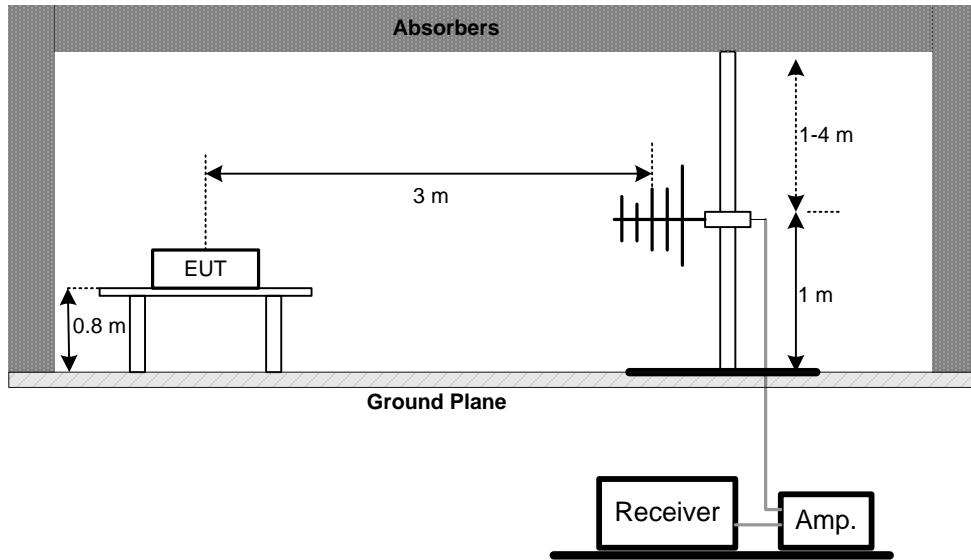

(B) Radiated Emission Test Set-Up Frequency Above 1 GHz

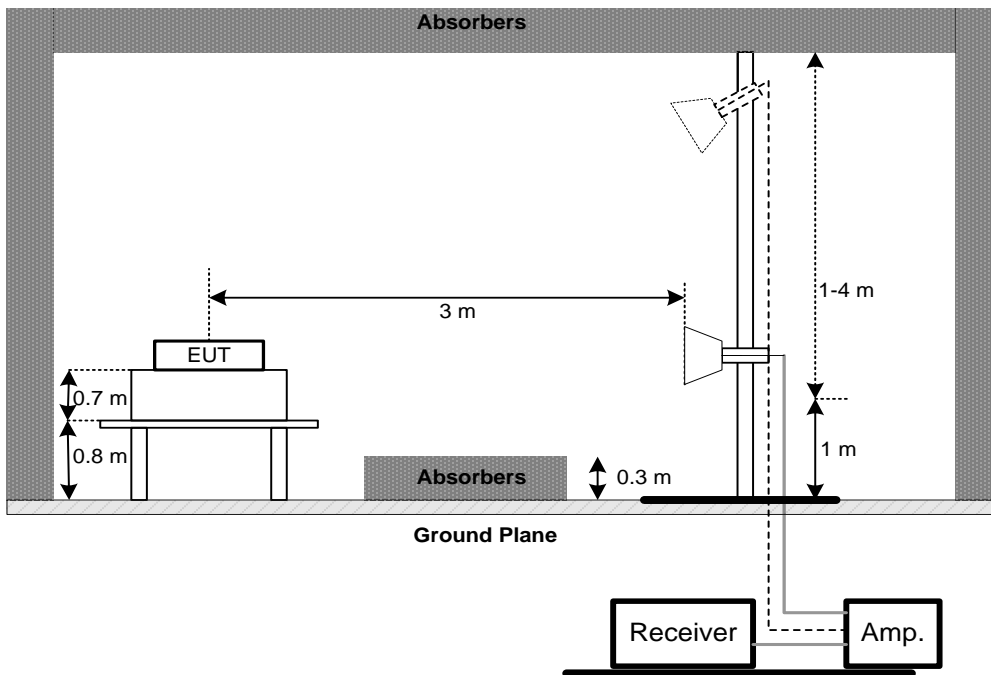

(C) Radiated emissions below 30MHz

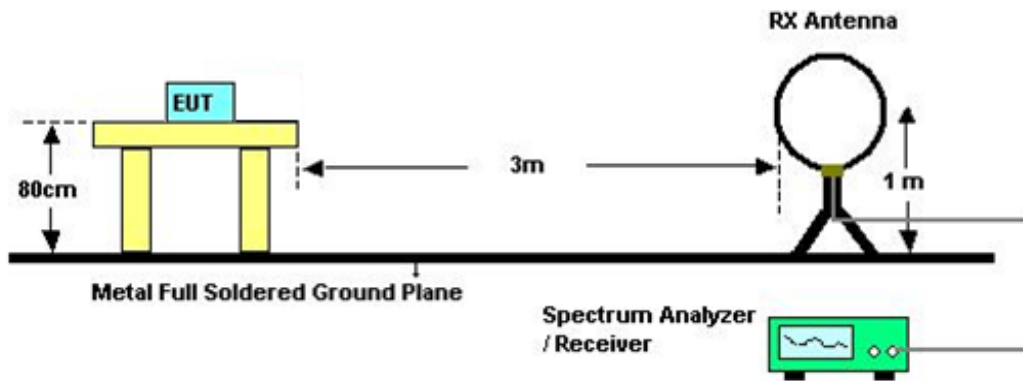

4.2.5 EUT OPERATING CONDITIONS

The EUT tested system was configured as the statements of 4.1.5 unless otherwise a special operating condition is specified in the follows during the testing.

4.2.6 EUT TEST CONDITIONS

Temperature: 25°C Relative Humidity: 60% Test Voltage: AC 120V/60Hz

4.2.7 TEST RESULTS (9K TO 30MHz)

Please refer to the Appendix B

Remark:

- (1) The amplitude of spurious emissions which are attenuated by more than 20 dB below the permissible value has no need to be reported.
- (2) Distance extrapolation factor = $40 \log$ (specific distance / test distance) (dB);
- (3) Limit line = specific limits (dBuV) + distance extrapolation factor.

4.2.8 TEST RESULTS (BETWEEN 30 TO 1000 MHz)

Please refer to the Appendix C.

4.2.9 TEST RESULTS (ABOVE 1000 MHz)

Please refer to the Appendix D.

Remark:

- (1) No limit: This is fundamental signal, the judgment is not applicable.
For fundamental signal judgment was referred to Peak output test.

5. 26dB SPECTRUM BANDWIDTH

5.1 APPLIED PROCEDURES / LIMIT

FCC Part15, Subpart E			
Test Item	Limit	Frequency Range (MHz)	Result
Bandwidth	26 dB Bandwidth	5150-5250	PASS
	Minimum 500kHz 6dB Bandwidth	5725-5850	PASS

5.1.1 TEST PROCEDURE

a. The EUT was directly connected to the spectrum analyzer and antenna output port as show in the block diagram below,

b.

Spectrum Parameters	Setting
Attenuation	Auto
Span Frequency	> 26dB Bandwidth
RBW	300 kHz(Bandwidth 20MHz) 1MHz(Bandwidth 40MHz and 80MHz)
VBW	1MHz(Bandwidth 20MHz) 3MHz(Bandwidth 40MHz and 80MHz)
Detector	Peak
Trace	Max Hold
Sweep Time	Auto

c. Measured the spectrum width with power higher than 26dB below carrier

5.1.2 DEVIATION FROM STANDARD

No deviation.

5.1.3 TEST SETUP



5.1.4 EUT OPERATION CONDITIONS

The EUT tested system was configured as the statements of 4.1.5 unless otherwise a special operating condition is specified in the follows during the testing.

5.1.5 EUT TEST CONDITIONS

Temperature: 25°C Relative Humidity: 60% Test Voltage: AC 120V/60Hz

5.1.6 TEST RESULTS

Please refer to the Appendix E.

6. MAXIMUM CONDUCTED OUTPUT POWER

6.1 APPLIED PROCEDURES / LIMIT

FCC Part15, Subpart E			
Test Item	Limit	Frequency Range (MHz)	Result
Conducted Output Power	Fixed:1 Watt (30dBm) Mobile and portable: 250mW (24dBm)	5150-5250	PASS
	1 Watt (30dBm)	5725-5850	PASS
Note: The maximum e.i.r.p at anyelevation angle above 30 degrees as measured from the horizon must not exceed 125mW(21dBm)			

6.1.1 TEST PROCEDURE

- The EUT was directly connected to the spectrum analyzer and antenna output port as show in the block diagram below,
- Used spectrum analyzer band power measurement function.
-

Spectrum Parameter	Setting
Attenuation	Auto
Span Frequency	Encompass the entire emissions bandwidth (EBW) of the signal
RBW	= 1MHz.
VBW	\geq 3MHz.
Sweep points	\geq 2 x span / RBW
Detector	RMS
Trace	Trace average at least 100 traces in power averaging(rms) mode.
Sweep Time	auto

- Test was performed in accordance with method of KDB 789033 D02.

6.1.2 DEVIATION FROM STANDARD

No deviation.

6.1.3 TEST SETUP



6.1.4 EUT OPERATION CONDITIONS

The EUT tested system was configured as the statements of 4.1.5 unless otherwise a special operating condition is specified in the follows during the testing.

6.1.5 EUT TEST CONDITIONS

Temperature: 25°C Relative Humidity: 60% Test Voltage: AC 120V/60Hz

6.1.6 TEST RESULTS

Please refer to the Appendix F.

7. POWER SPECTRAL DENSITY TEST

7.1 APPLIED PROCEDURES / LIMIT

FCC Part15, Subpart E			
Test Item	Limit	Frequency Range (MHz)	Result
Power Spectral Density	Other then Mobile and portable:17dBm/MHz Mobile and portable:11dBm/MHz	5150-5250	PASS
	30dBm/500kHz	5725-5850	PASS

8.1.1 TEST PROCEDURE

a. The EUT was directly connected to the spectrum analyzer and antenna output port as show in the block diagram below,

b.

Spectrum Parameter	Setting
Attenuation	Auto
Span Frequency	Encompass the entire emissions bandwidth (EBW) of the signal
RBW	= 1MHz.
VBW	≥ 3MHz.
Detector	RMS
Trace average	100 trace
Sweep Time	Auto

Note:

- For UNII-3, according to KDB publication 789033 D02 General UNII Test Procedures New Rules v01r02, section II.F.5., it is acceptable to set RBW at 1MHz and VBW at 3MHz if the spectrum analyzer does not have 500kHz RBW.
- The value measured with RBW=1MHz is to be added with $10\log(500\text{kHz}/1\text{MHz})$ which is -3dB. For example, if the measured value is +10dBm using RBW=1MHz (that is +10dBm/MHz), then the converted value will be +7dBm/500kHz.

7.1.1 DEVIATION FROM STANDARD

No deviation.

7.1.2 TEST SETUP

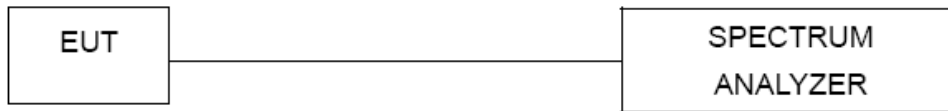

7.1.3 EUT OPERATION CONDITIONS

The EUT tested system was configured as the statements of 4.1.5 unless otherwise a special operating condition is specified in the follows during the testing.

7.1.4 EUT TEST CONDITIONS

Temperature: 25°C Relative Humidity: 60% Test Voltage: AC 120V/60Hz

7.1.5 TEST RESULTS

Please refer to the Appendix H.

8. FREQUENCY STABILITY MEASUREMENT

8.1 APPLIED PROCEDURES / LIMIT

FCC Part15, Subpart E			
Test Item	Limit	Frequency Range (MHz)	Result
Frequency Stability	Specified in the user's manual	5150-5250	PASS
		5725-5850	PASS

8.1.1 TEST PROCEDURE

a. The EUT was directly connected to the spectrum analyzer and antenna output port as show in the block diagram below,

b.

Spectrum Parameter	Setting
Attenuation	Auto
Span Frequency	Entire absence of modulation emissions bandwidth
RBW	10 kHz
VBW	10 kHz
Sweep Time	Auto

c. The test extreme voltage is to change the primary supply voltage from 85 to 115 percent of the nominal value.

d. User manual temperature is 0°C~40°C.

8.1.2 DEVIATION FROM STANDARD

No deviation.

8.1.3 TEST SETUP

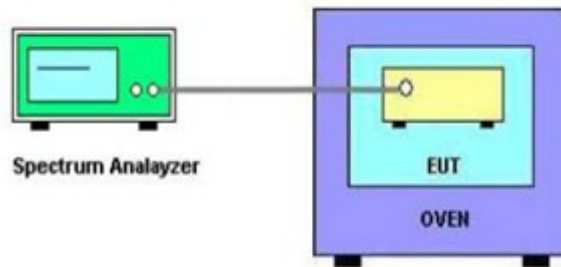

8.1.4 EUT OPERATION CONDITIONS

The EUT tested system was configured as the statements of 4.1.5 unless otherwise a special operating condition is specified in the follows during the testing.

8.1.5 EUT TEST CONDITIONS

Temperature: 25°C Relative Humidity: 55% Test Voltage: AC 120V/60Hz

8.1.6 TEST RESULTS

Please refer to the Appendix I.

9. MEASUREMENT INSTRUMENTS LIST

Conducted Emission Measurement					
Item	Kind of Equipment	Manufacturer	Type No.	Serial No.	Calibrated until
1	EMI Test Receiver	R&S	ESCI	100382	Mar. 11, 2019
2	LISN	EMCO	3816/2	52765	Mar. 11, 2019
3	50Ω Terminator	SHX	TF2-3G-A	8122901	Mar. 11, 2019
4	TWO-LINE V-NETWORK	R&S	ENV216	101447	Mar. 11, 2019
5	Measurement Software	Farad	EZ-EMC Ver.NB-03A1-01	N/A	N/A
6	Cable	N/A	RG223	12m	Oct. 19, 2018

Radiated Emission Measurement - Below 1GHz					
Item	Kind of Equipment	Manufacturer	Type No.	Serial No.	Calibrated until
1	Antenna	Schwarbeck	VULB9160	9160-3232	Mar. 11, 2019
2	Amplifier	HP	8447D	2944A09673	Oct. 19, 2018
3	Receiver	Agilent	N9038A	MY52130039	Aug. 20, 2018
4	Cable	emci	LMR-400(30MHz-1 GHz)(8m+5m)	N/A	Jun. 26, 2018
5	Controller	CT	SC100	N/A	N/A
6	Controller	MF	MF-7802	MF780208416	N/A
7	Measurement Software	Farad	EZ-EMC Ver.NB-03A1-01	N/A	N/A
8	Antenna	EM	EM-6876-1	230	Feb. 07, 2019

Radiated Emission Measurement - Above 1GHz					
Item	Kind of Equipment	Manufacturer	Type No.	Serial No.	Calibrated until
1	Double Ridged Guide Antenna	ETS	3115	75789	Mar. 11, 2019
2	Broad-Band Horn Antenna	Schwarzbeck	BBHA 9170	9170319	Jun. 08, 2018
3	Amplifier	Agilent	8449B	3008A02274	Mar. 11, 2019
4	Microwave Preamplifier With Adaptor	EMC INSTRUMENT	EMC2654045	980039 & HA01	Mar. 11, 2019
5	Receiver	Agilent	N9038A	MY52130039	Aug. 20, 2018
6	Controller	CT	SC100	N/A	N/A
7	Controller	MF	MF-7802	MF780208416	N/A
8	Cable	emci	EMC104-SM-SM-1 2000(12m)	N/A	Jun. 26, 2018
9	Measurement Software	Farad	EZ-EMC Ver.NB-03A1-01	N/A	N/A

Spectrum Bandwidth Measurement					
Item	Kind of Equipment	Manufacturer	Type No.	Serial No.	Calibrated until
1	Spectrum Analyzer	R&S	FSP40	100185	Aug. 20, 2018

Maximum Conducted Output Power Measurement					
Item	Kind of Equipment	Manufacturer	Type No.	Serial No.	Calibrated until
1	Spectrum Analyzer	R&S	FSP40	100185	Aug. 20, 2018

Power Spectral Density Measurement					
Item	Kind of Equipment	Manufacturer	Type No.	Serial No.	Calibrated until
1	Spectrum Analyzer	R&S	FSP40	100185	Aug. 20, 2018

Frequency Stability Measurement					
Item	Kind of Equipment	Manufacturer	Type No.	Serial No.	Calibrated until
1	Spectrum Analyzer	R&S	FSP40	100185	Aug. 20, 2018
2	Precision Oven Tester	Bell	BTH-50C	20170306001	Mar. 11, 2019

Remark: "N/A" denotes no model name, serial no. or calibration specified.
 All calibration period of equipment list is one year.

10. EUT TEST PHOTOS

Conducted Measurement Photos



Radiated Measurement Photos

9kHz to 30MHz

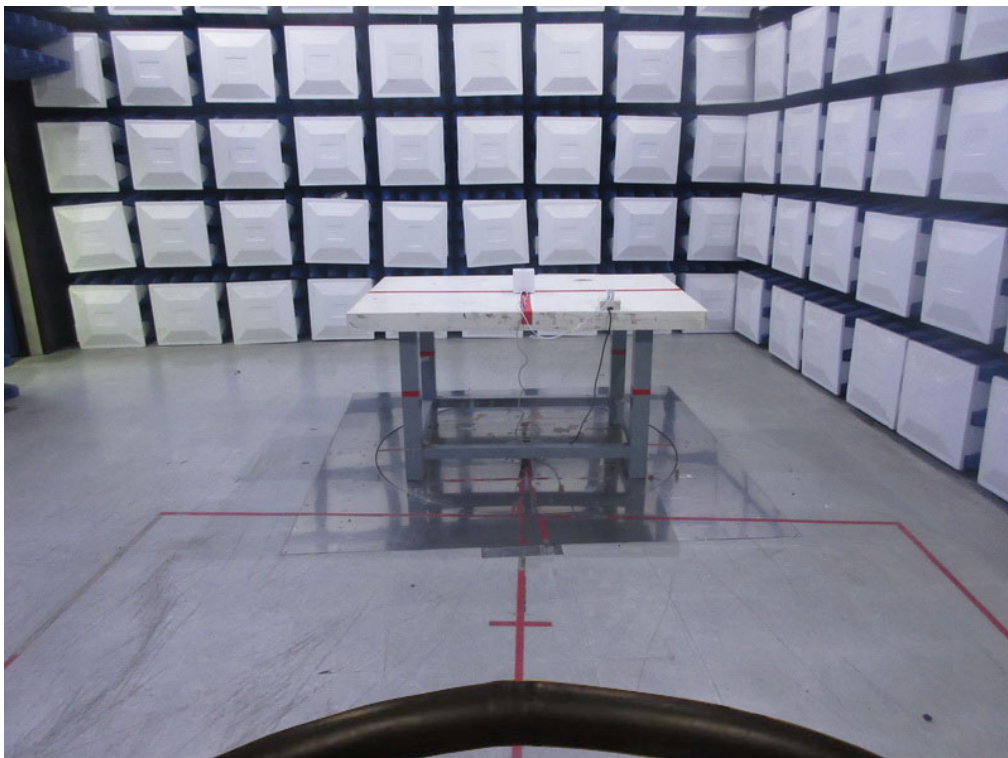

Radiated Measurement Photos

30MHz to 1000MHz



Radiated Measurement Photos

Above 1000MHz

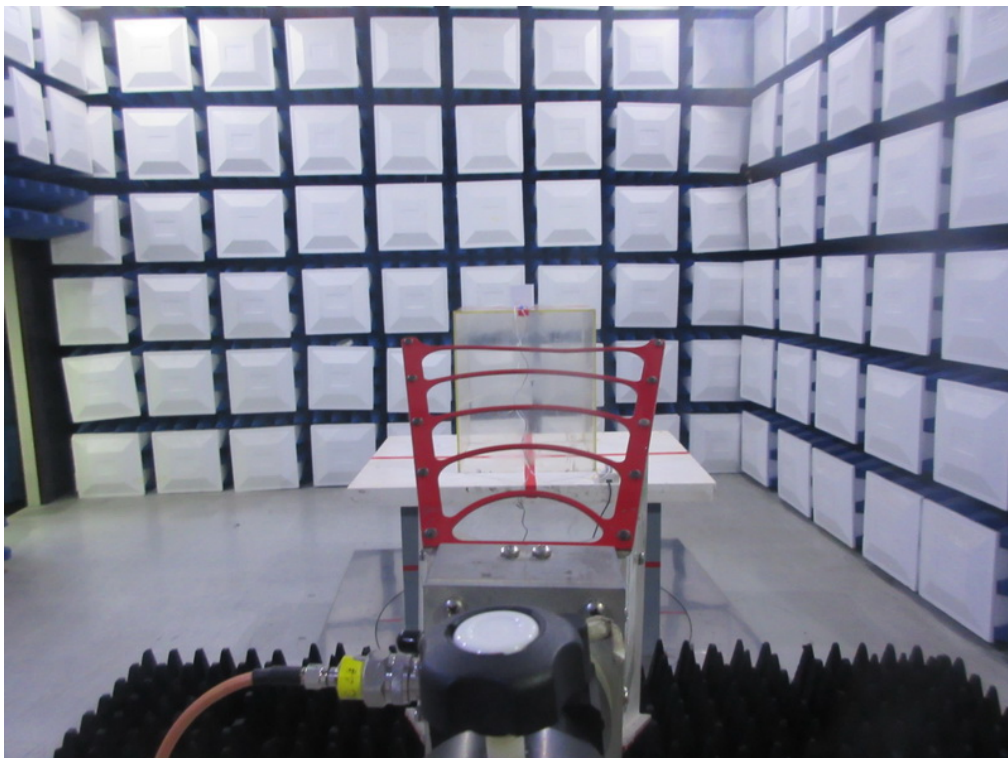
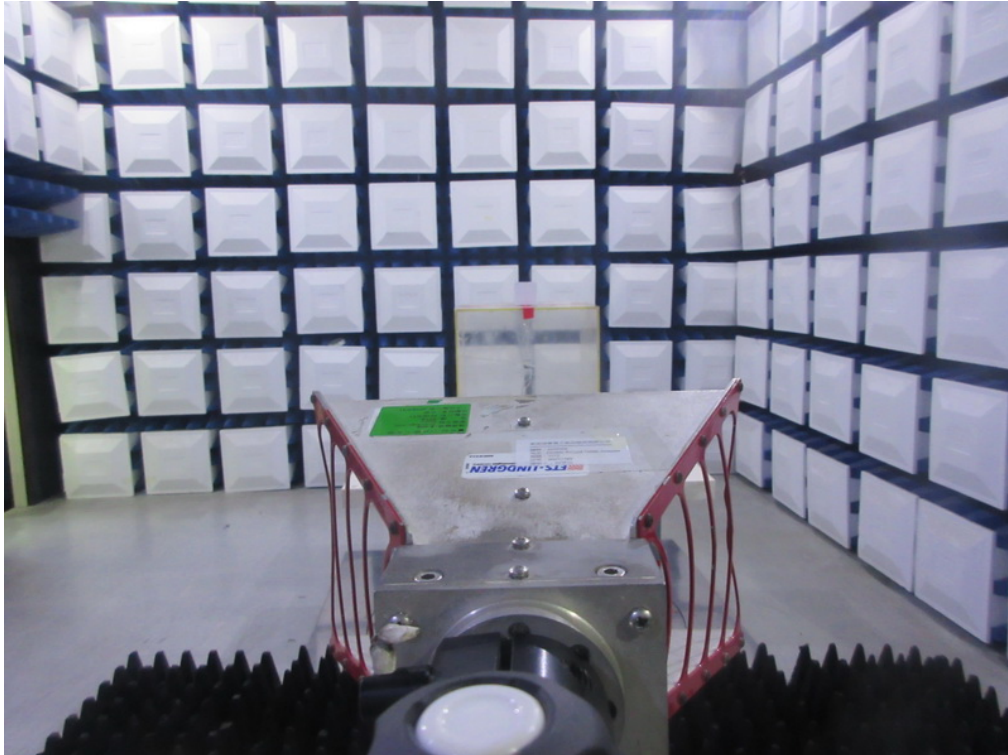

APPENDIX A - CONDUCTED EMISSION

Test Mode: TX MODE

Line

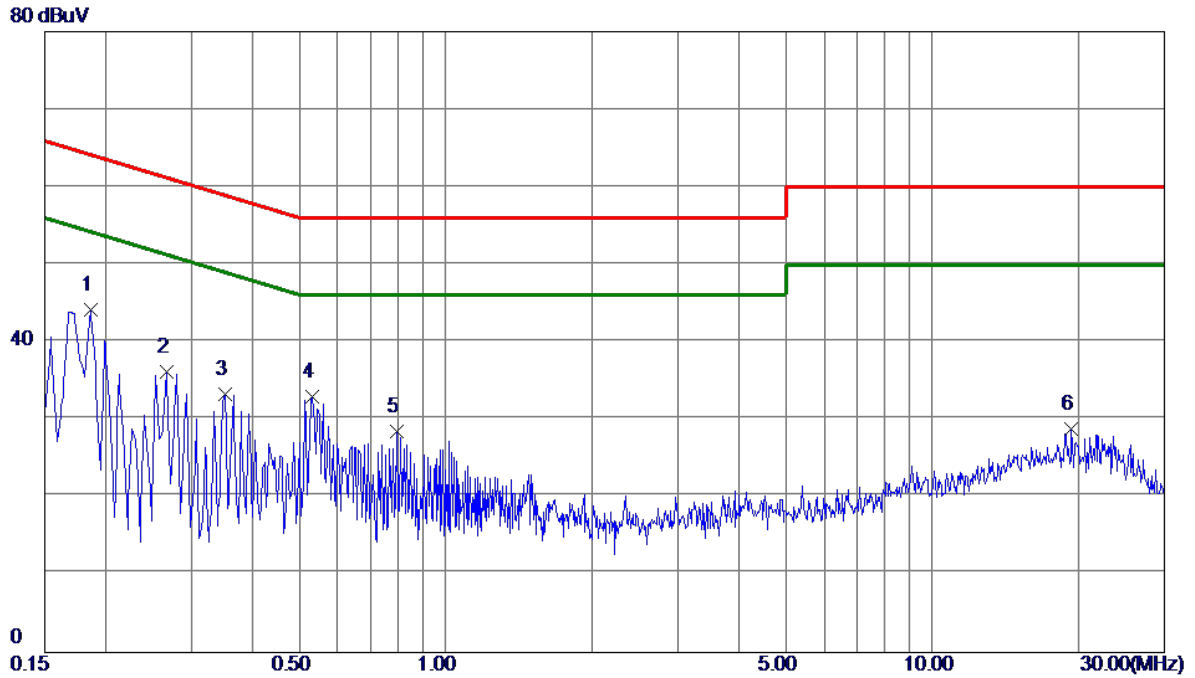

No.	Freq. MHz	Reading Level dBuV	Correct Factor dB	Measure ment dBuV	Limit dBuV	Margin dB	Detector	Comment
1 *	0.1860	34.34	9.82	44.16	64.21	-20.05	Peak	
2	0.2670	26.34	9.82	36.16	61.21	-25.05	Peak	
3	0.3525	23.49	9.81	33.30	58.90	-25.60	Peak	
4	0.5325	23.20	9.80	33.00	56.00	-23.00	Peak	
5	0.7935	18.51	9.91	28.42	56.00	-27.58	Peak	
6	19.3425	17.66	11.13	28.79	60.00	-31.21	Peak	

Note : The test result has included the cable loss.

Test Mode: TX MODE

Neutral

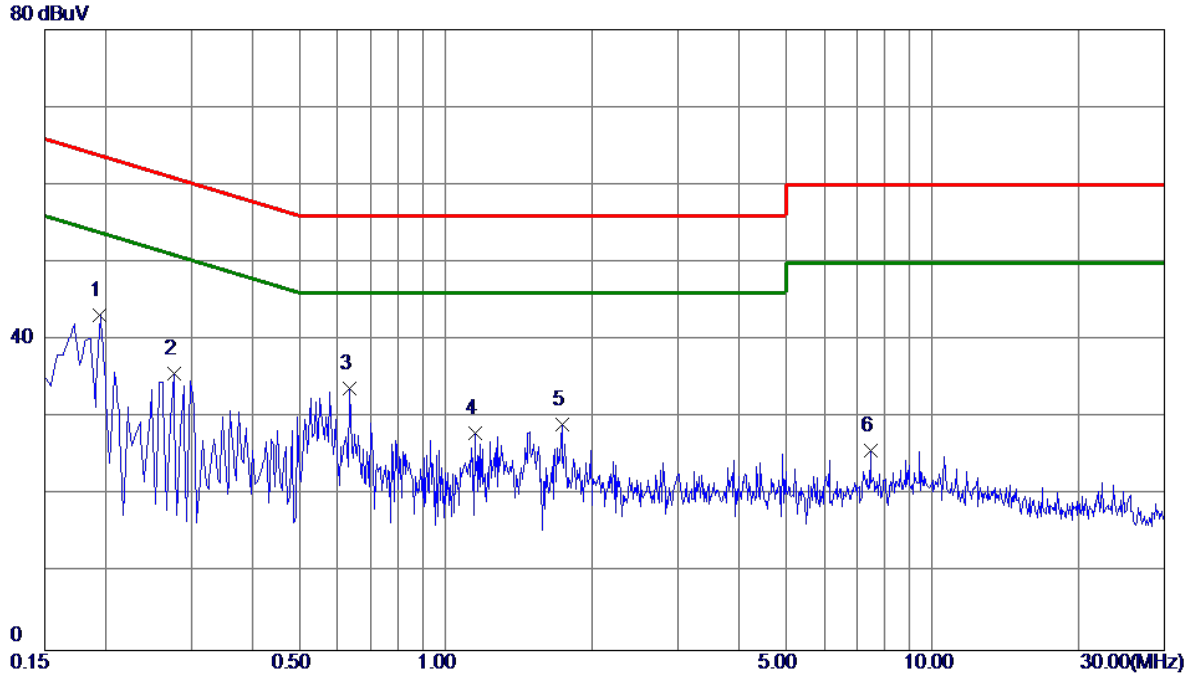

No.	Freq. MHz	Reading Level dBuV	Correct Factor dB	Measure ment dBuV	Limit dBuV	Margin dB	Detector	Comment
1 *	0.1949	33.34	9.91	43.25	63.83	-20.58	Peak	
2	0.2760	25.69	9.93	35.62	60.94	-25.32	Peak	
3	0.6360	23.83	10.00	33.83	56.00	-22.17	Peak	
4	1.1490	17.83	10.13	27.96	56.00	-28.04	Peak	
5	1.7340	18.93	10.17	29.10	56.00	-26.90	Peak	
6	7.4625	15.18	10.61	25.79	60.00	-34.21	Peak	

Note : The test result has included the cable loss.

APPENDIX B - RADIATED EMISSION (9KHZ TO 30MHZ)

Test Mode: TX MODE

Ant 0°

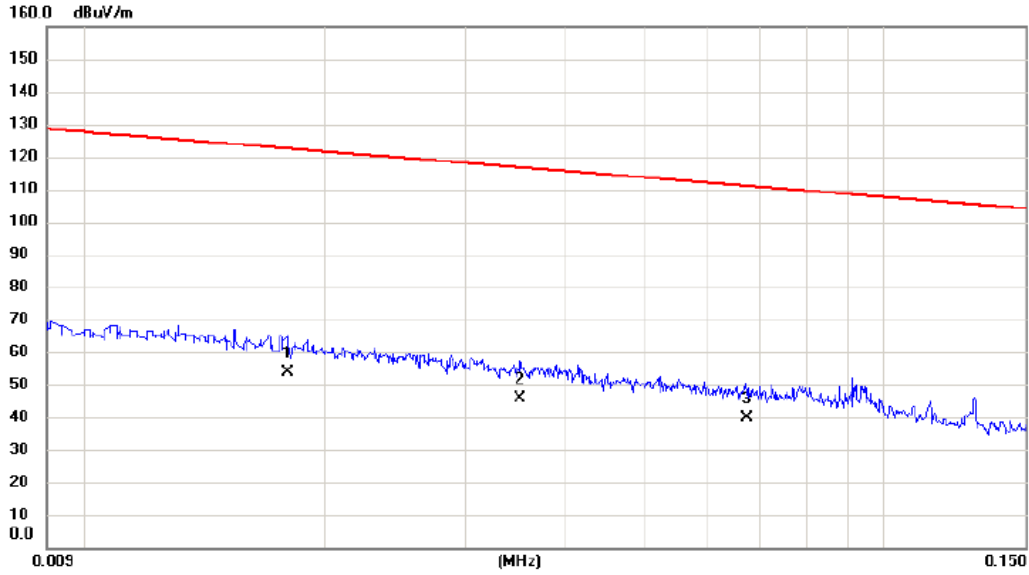

No.	Mk.	Freq. MHz	Reading Level dBuV/m	Correct Factor dB	Measure- ment dBuV/m	Limit dBuV/m	Margin dB	Detector	Comment
1	*	0.0180	33.81	19.88	53.69	122.50	-68.81	AVG	
2		0.0351	26.70	19.17	45.87	116.70	-70.83	AVG	
3		0.0673	21.50	18.38	39.88	111.04	-71.16	AVG	

Test Mode: TX MODE

Ant 0°

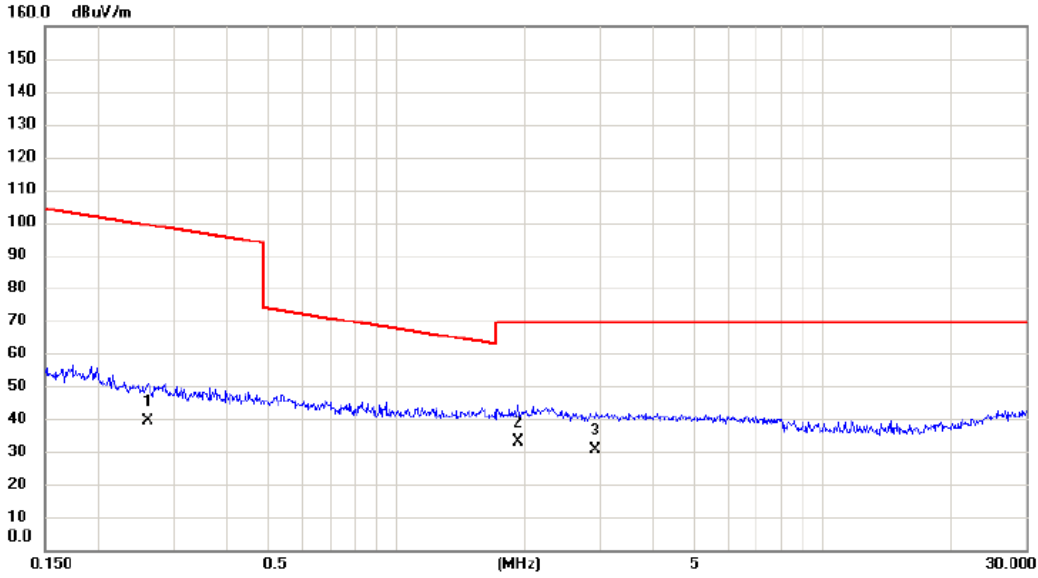

No.	Mk.	Freq. MHz	Reading Level dBuV/m	Correct Factor dB	Measure- ment dBuV/m	Limit dBuV/m	Margin dB	Detector	Comment
1		0.2615	22.70	16.65	39.35	99.26	-59.91	AVG	
2	*	1.9284	17.50	15.54	33.04	69.54	-36.50	QP	
3		2.9307	15.30	15.25	30.55	69.54	-38.99	QP	

Test Mode: TX MODE

Ant 90°

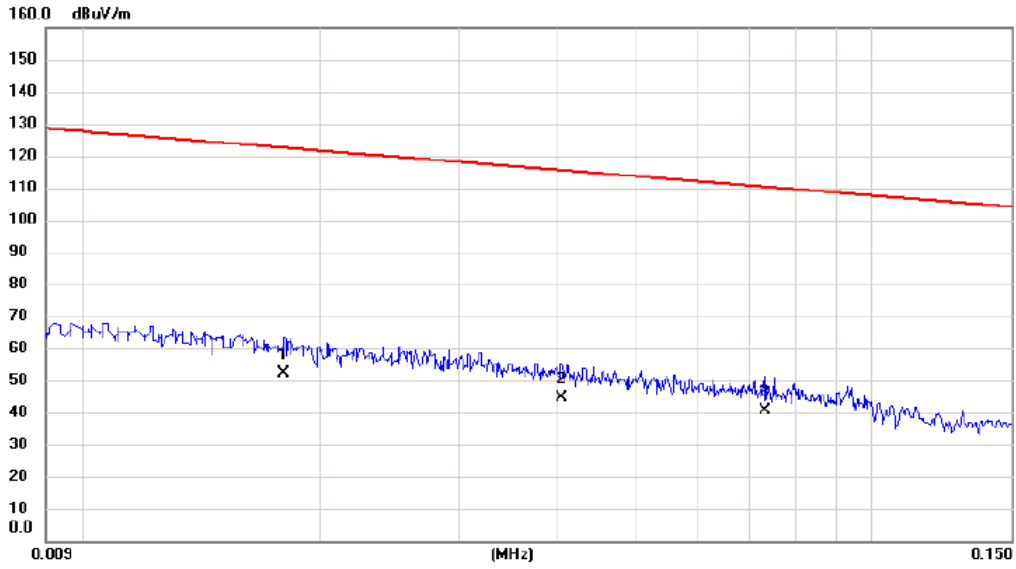

No.	Mk.	Freq.	Reading Level	Correct Factor	Measurement	Limit	Margin	Detector	Comment
		MHz	dBuV/m	dB	dBuV/m	dBuV/m	dB		
1		0.0180	32.50	19.88	52.38	122.50	-70.12	AVG	
2		0.0404	25.60	19.01	44.61	115.48	-70.87	AVG	
3	*	0.0730	22.30	18.27	40.57	110.34	-69.77	AVG	

Test Mode: TX MODE

Ant 90°

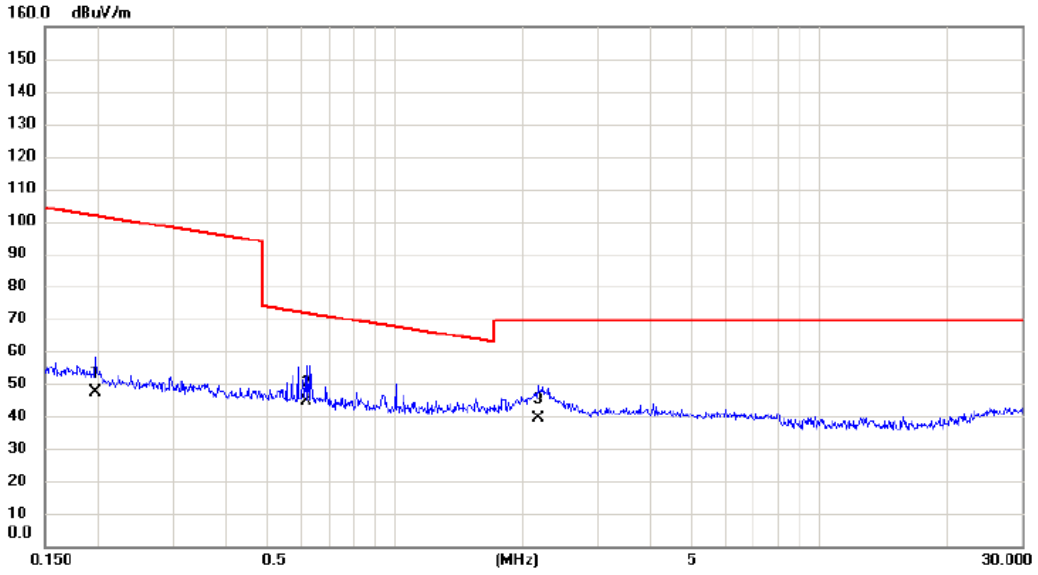

No.	Mk.	Freq. MHz	Reading Level dBuV/m	Correct Factor dB	Measure- ment dBuV/m	Limit dBuV/m	Margin dB	Detector	Comment
1		0.1965	30.50	16.81	47.31	101.74	-54.43	AVG	
2	*	0.6173	28.10	16.33	44.43	71.79	-27.36	QP	
3		2.1783	23.90	15.46	39.36	69.54	-30.18	QP	

APPENDIX C - RADIATED EMISSION (30MHZ TO 1000MHZ)

Test Mode: UNII-1/TX A Mode 5180MHz

Vertical

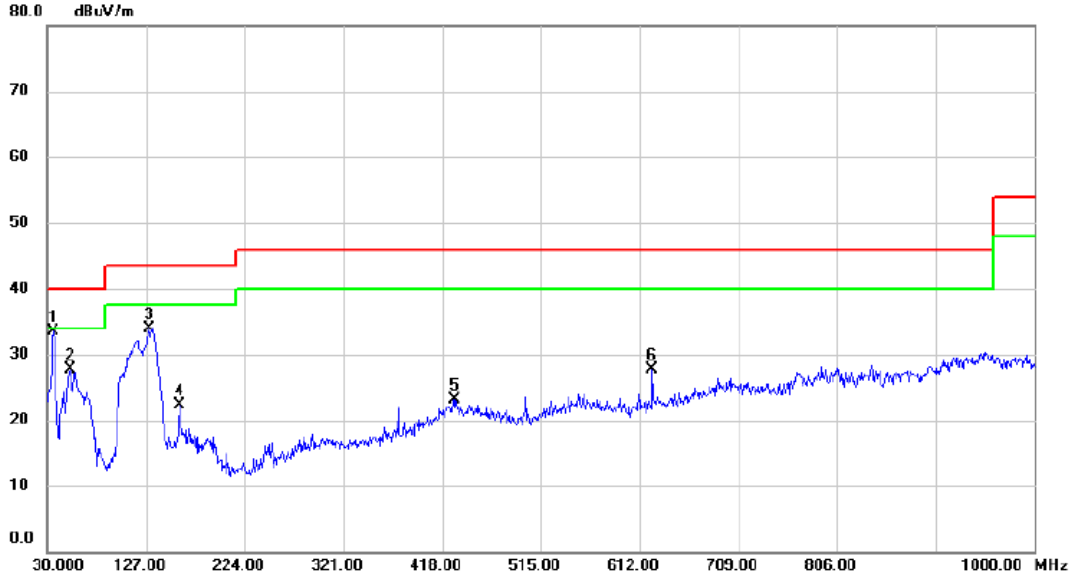

No.	Mk.	Freq. MHz	Reading Level dBuV	Correct Factor dB	Measure- ment dBuV/m	Limit dBuV/m	Margin dB	Detector	Comment
1	*	35.820	48.80	-15.34	33.46	40.00	-6.54	peak	
2		52.310	42.97	-15.35	27.62	40.00	-12.38	peak	
3		129.910	48.03	-14.05	33.98	43.50	-9.52	peak	
4		159.980	33.68	-11.29	22.39	43.50	-21.11	peak	
5		429.640	32.00	-8.91	23.09	46.00	-22.91	peak	
6		624.610	34.04	-6.43	27.61	46.00	-18.39	peak	

Test Mode: UNII-1/TX A Mode 5180MHz

Horizontal

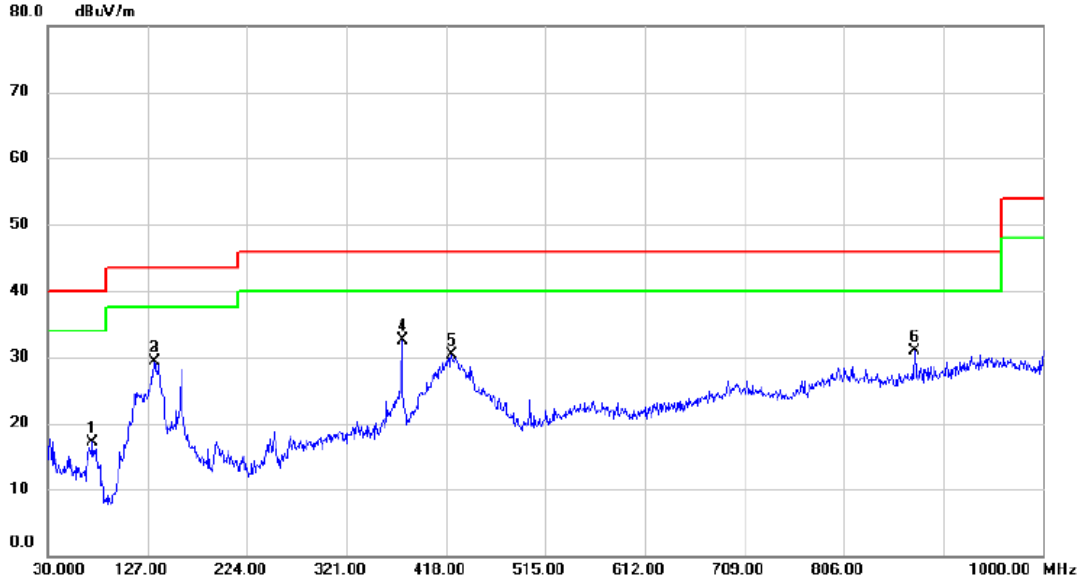

No.	Mk.	Freq. MHz	Reading Level dBuV	Correct Factor dB	Measure- ment dBuV/m	Limit dBuV/m	Margin dB	Detector	Comment
1		73.650	35.76	-18.68	17.08	40.00	-22.92	peak	
2		133.790	42.92	-13.56	29.36	43.50	-14.14	peak	
3		133.790	42.92	-13.56	29.36	43.50	-14.14	peak	
4	*	375.320	43.46	-10.94	32.52	46.00	-13.48	peak	
5		423.820	39.55	-9.15	30.40	46.00	-15.60	peak	
6		874.870	32.62	-1.74	30.88	46.00	-15.12	peak	

Test Mode: UNII-1/TX A Mode 5200MHz

Vertical

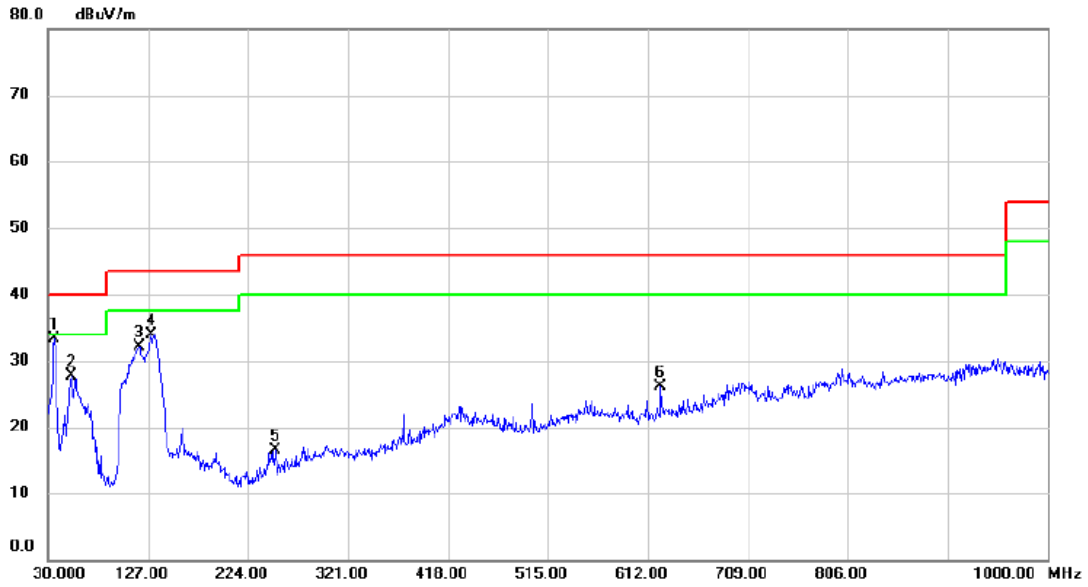

No.	Mk.	Freq. MHz	Reading Level dBuV	Correct Factor dB	Measure- ment dBuV/m	Limit dBuV/m	Margin dB	Detector	Comment
1	*	35.820	48.69	-15.34	33.35	40.00	-6.65	peak	
2		52.310	42.97	-15.35	27.62	40.00	-12.38	peak	
3		118.270	47.70	-15.60	32.10	43.50	-11.40	peak	
4		129.910	48.03	-14.05	33.98	43.50	-9.52	peak	
5		250.190	31.57	-15.02	16.55	46.00	-29.45	peak	
6		624.610	32.51	-6.43	26.08	46.00	-19.92	peak	

Test Mode: UNII-1/TX A Mode 5200MHz

Horizontal

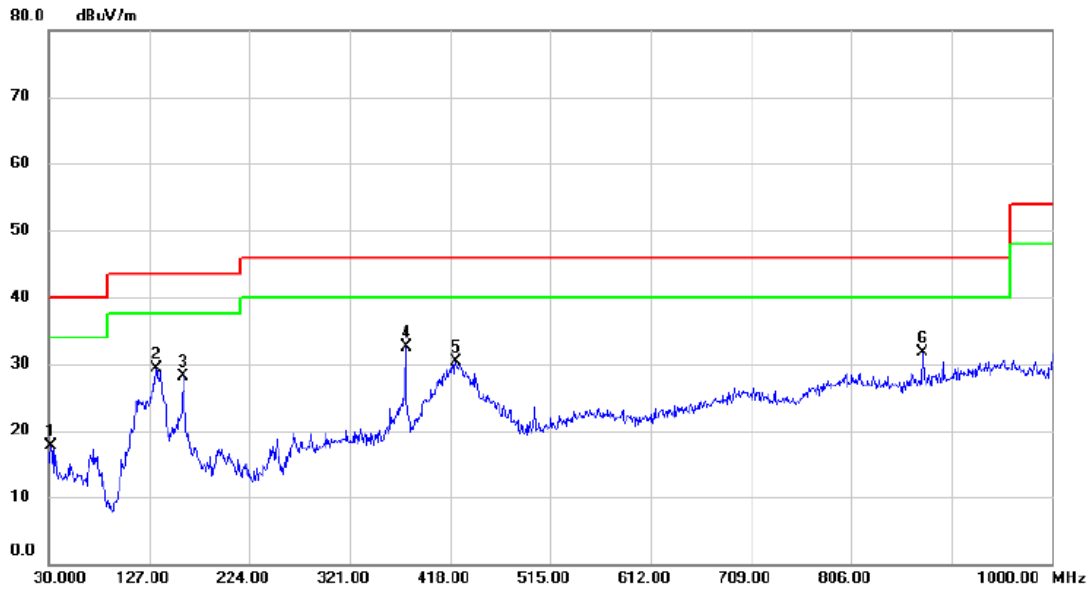

No.	Mk.	Freq. MHz	Reading Level dBuV	Correct Factor dB	Measure- ment dBuV/m	Limit dBuV/m	Margin dB	Detector	Comment
1		31.940	33.15	-15.40	17.75	40.00	-22.25	peak	
2		133.790	42.92	-13.56	29.36	43.50	-14.14	peak	
3		159.980	39.38	-11.29	28.09	43.50	-15.41	peak	
4	*	375.320	43.46	-10.94	32.52	46.00	-13.48	peak	
5		423.820	39.55	-9.15	30.40	46.00	-15.60	peak	
6		874.870	33.49	-1.74	31.75	46.00	-14.25	peak	

Test Mode: UNII-1/TX A Mode 5240MHz

Vertical

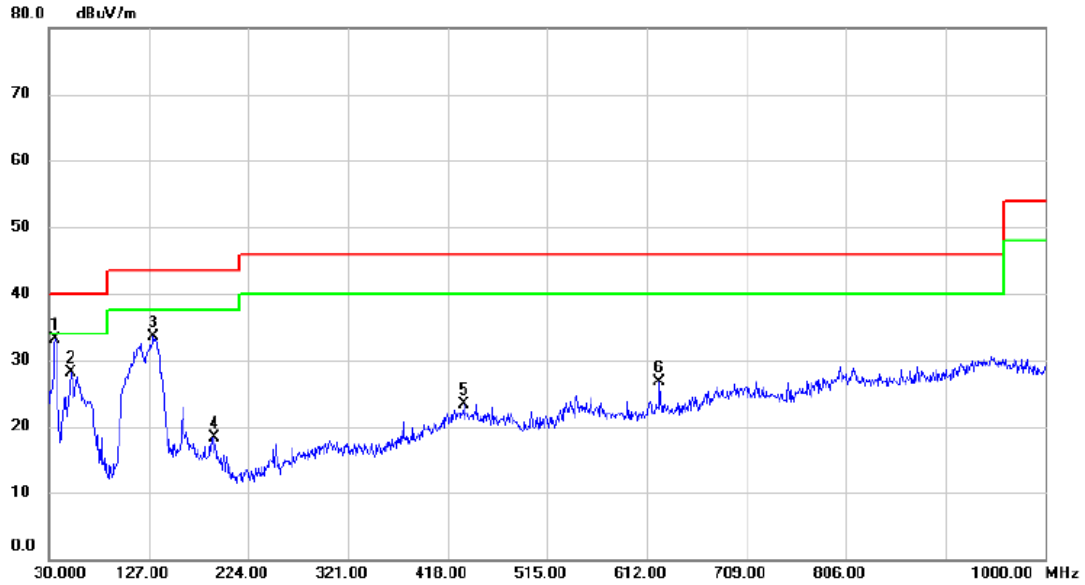

No.	Mk.	Freq. MHz	Reading Level dBuV	Correct Factor dB	Measure- ment dBuV/m	Limit dBuV/m	Margin dB	Detector	Comment
1	*	35.820	48.52	-15.34	33.18	40.00	-6.82	peak	
2		51.340	43.45	-15.31	28.14	40.00	-11.86	peak	
3		131.850	47.31	-13.80	33.51	43.50	-9.99	peak	
4		191.020	33.45	-15.13	18.32	43.50	-25.18	peak	
5		433.520	32.02	-8.77	23.25	46.00	-22.75	peak	
6		624.610	33.09	-6.43	26.66	46.00	-19.34	peak	

Test Mode: UNII-1/TX A Mode 5240MHz

Horizontal

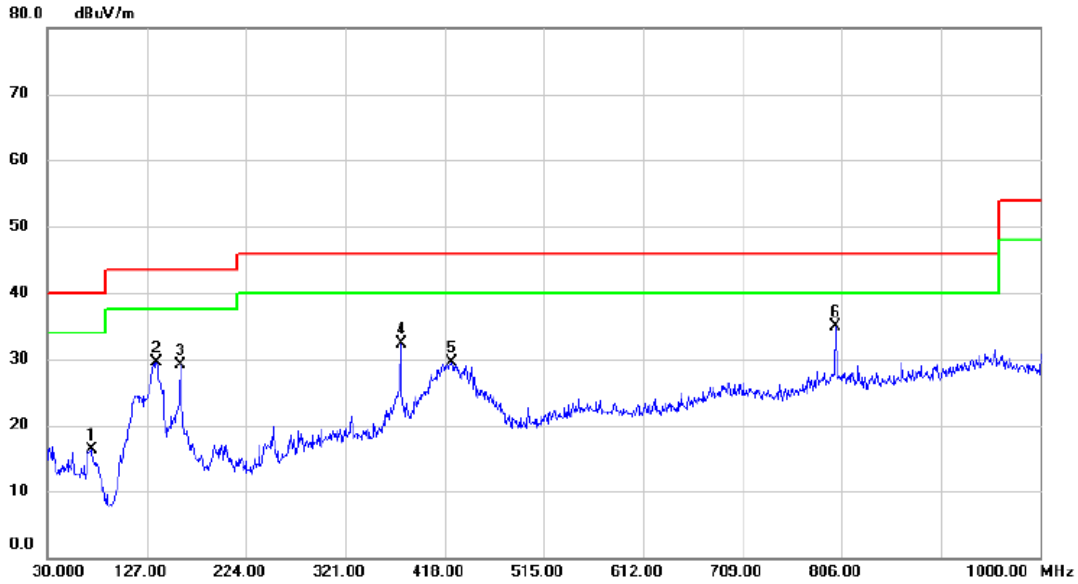

No.	Mk.	Freq. MHz	Reading Level dBuV	Correct Factor dB	Measure- ment dBuV/m	Limit dBuV/m	Margin dB	Detector	Comment
1		72.680	34.79	-18.47	16.32	40.00	-23.68	peak	
2		136.700	42.76	-13.19	29.57	43.50	-13.93	peak	
3		159.980	40.38	-11.29	29.09	43.50	-14.41	peak	
4		375.320	43.34	-10.94	32.40	46.00	-13.60	peak	
5		424.790	38.62	-9.12	29.50	46.00	-16.50	peak	
6	*	800.180	36.45	-1.62	34.83	46.00	-11.17	peak	

Test Mode: UNII-3/TX A Mode 5745MHz

Vertical

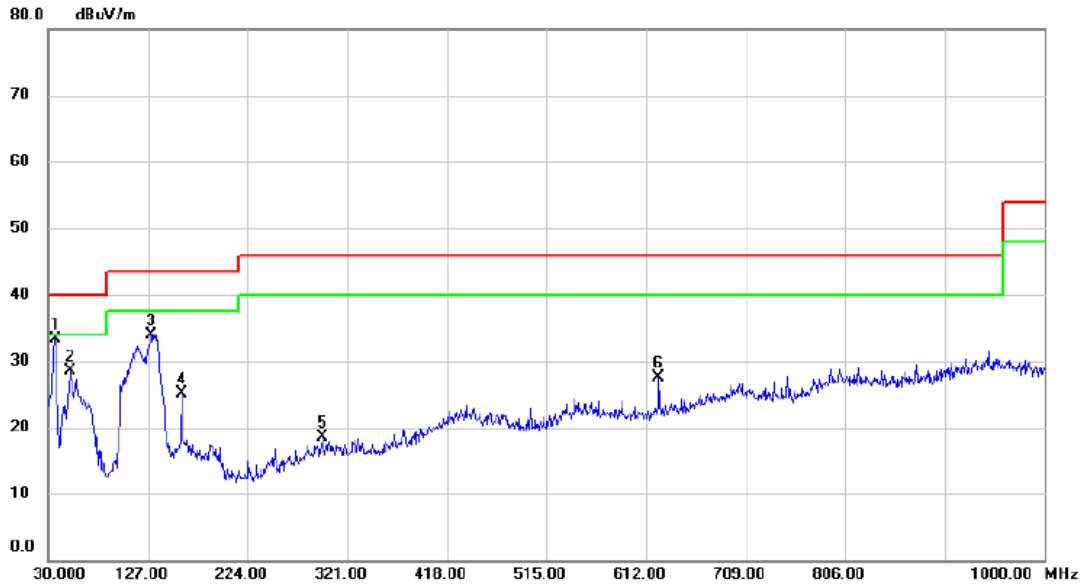

No.	Mk.	Freq. MHz	Reading Level dBuV	Correct Factor dB	Measure- ment dBuV/m	Limit dBuV/m	Margin dB	Detector	Comment
1	*	36.790	48.61	-15.24	33.37	40.00	-6.63	peak	
2		51.340	43.77	-15.31	28.46	40.00	-11.54	peak	
3		129.910	48.04	-14.05	33.99	43.50	-9.51	peak	
4		159.980	36.49	-11.29	25.20	43.50	-18.30	peak	
5		296.750	29.82	-11.31	18.51	46.00	-27.49	peak	
6		624.610	33.86	-6.43	27.43	46.00	-18.57	peak	

Test Mode: UNII-3/TX A Mode 5745MHz

Horizontal

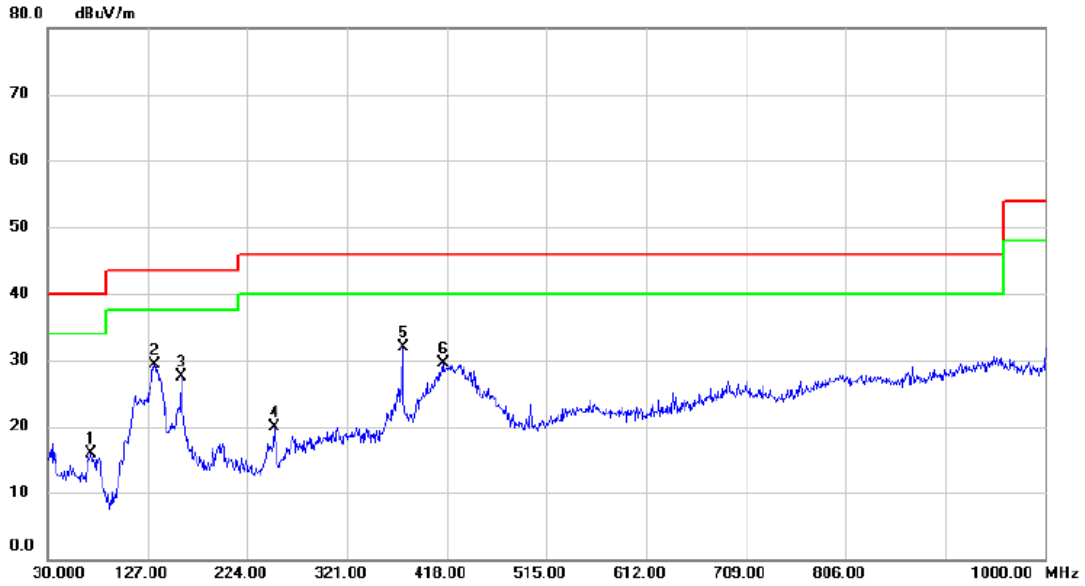

No.	Mk.	Freq. MHz	Reading Level dBuV	Correct Factor dB	Measure- ment dBuV/m	Limit dBuV/m	Margin dB	Detector	Comment
1		71.710	34.21	-18.27	15.94	40.00	-24.06	peak	
2		133.790	42.89	-13.56	29.33	43.50	-14.17	peak	
3		159.980	38.74	-11.29	27.45	43.50	-16.05	peak	
4		250.190	34.83	-15.02	19.81	46.00	-26.19	peak	
5	*	375.320	42.81	-10.94	31.87	46.00	-14.13	peak	
6		414.120	39.09	-9.54	29.55	46.00	-16.45	peak	

Test Mode: UNII-3/TX A Mode 5785MHz

Vertical

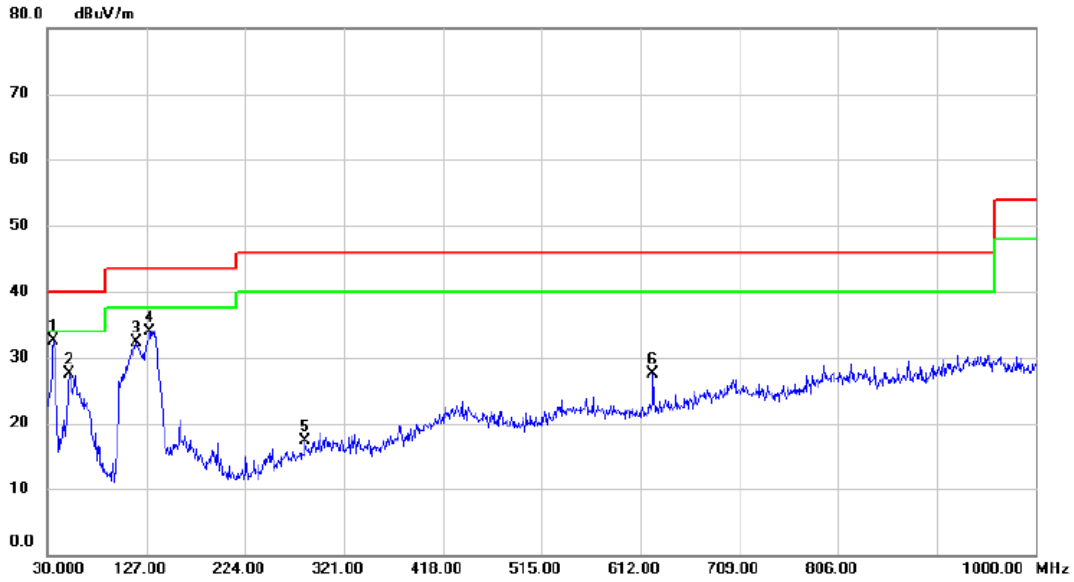

No.	Mk.	Freq. MHz	Reading Level dBuV	Correct Factor dB	Measure- ment dBuV/m	Limit dBuV/m	Margin dB	Detector	Comment
1	*	35.820	47.92	-15.34	32.58	40.00	-7.42	peak	
2		51.340	42.80	-15.31	27.49	40.00	-12.51	peak	
3		117.300	47.99	-15.76	32.23	43.50	-11.27	peak	
4		129.910	48.04	-14.05	33.99	43.50	-9.51	peak	
5		283.170	29.17	-11.96	17.21	46.00	-28.79	peak	
6		624.610	33.86	-6.43	27.43	46.00	-18.57	peak	

Test Mode: UNII-3/TX A Mode 5785MHz

Horizontal

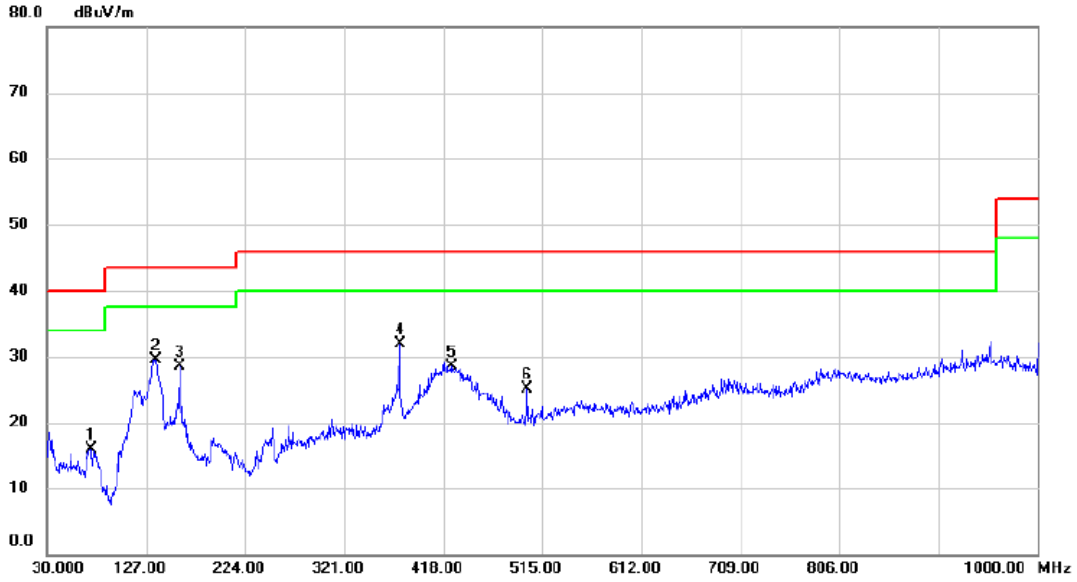

No. Mk.	Freq. MHz	Reading Level dBuV	Correct Factor dB	Measurement dBuV/m	Limit dBuV/m	Margin dB	Detector	Comment
1	72.680	34.31	-18.47	15.84	40.00	-24.16	peak	
2 *	136.700	42.78	-13.19	29.59	43.50	-13.91	peak	
3	159.980	39.77	-11.29	28.48	43.50	-15.02	peak	
4	375.320	42.90	-10.94	31.96	46.00	-14.04	peak	
5	426.730	37.63	-9.04	28.59	46.00	-17.41	peak	
6	500.450	34.23	-9.20	25.03	46.00	-20.97	peak	

Test Mode: UNII-3/TX A Mode 5825MHz

Vertical

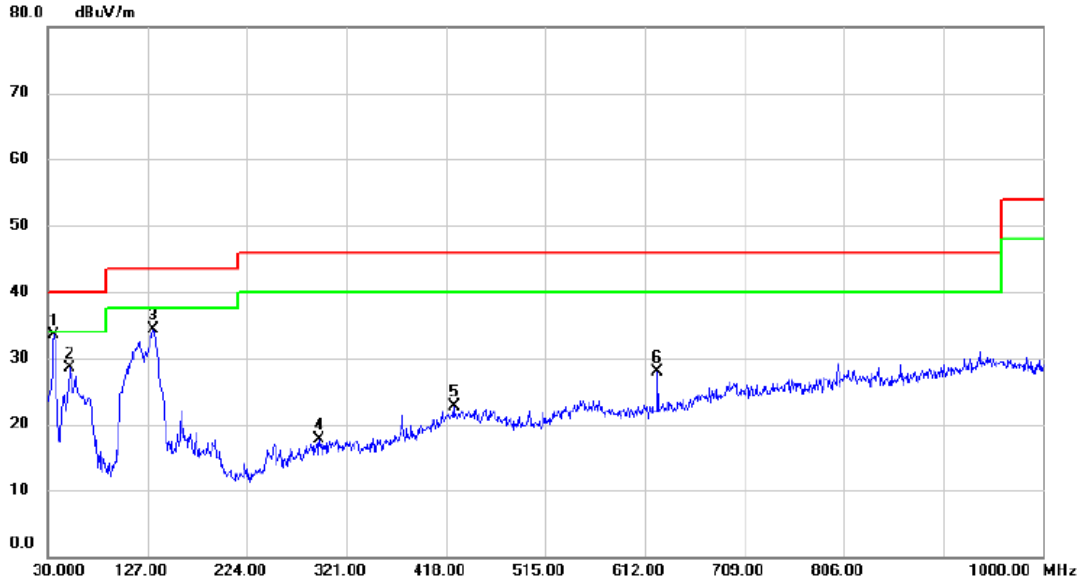

No.	Mk.	Freq. MHz	Reading Level dBuV	Correct Factor dB	Measure- ment dBuV/m	Limit dBuV/m	Margin dB	Detector	Comment
1	*	35.820	48.86	-15.34	33.52	40.00	-6.48	peak	
2		51.340	43.85	-15.31	28.54	40.00	-11.46	peak	
3		132.820	48.04	-13.68	34.36	43.50	-9.14	peak	
4		294.810	29.16	-11.43	17.73	46.00	-28.27	peak	
5		425.760	31.80	-9.07	22.73	46.00	-23.27	peak	
6		624.610	34.32	-6.43	27.89	46.00	-18.11	peak	

Test Mode: UNII-3/TX A Mode 5825MHz

Horizontal

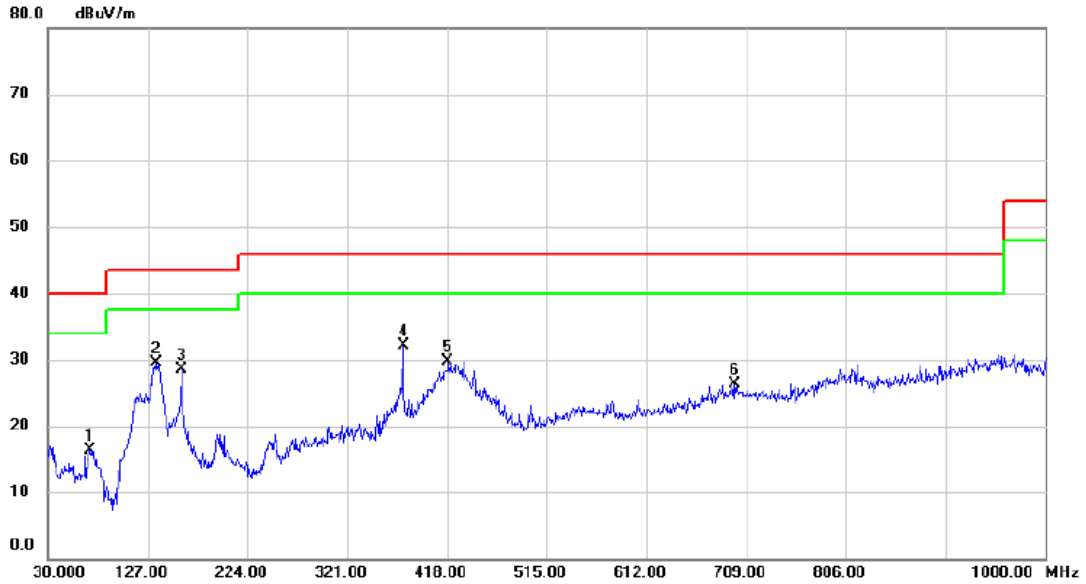

No.	Mk.	Freq. MHz	Reading Level dBuV	Correct Factor dB	Measure- ment dBuV/m	Limit dBuV/m	Margin dB	Detector	Comment
1		70.740	34.43	-18.07	16.36	40.00	-23.64	peak	
2		135.730	42.75	-13.30	29.45	43.50	-14.05	peak	
3		159.980	39.84	-11.29	28.55	43.50	-14.95	peak	
4	*	375.320	42.99	-10.94	32.05	46.00	-13.95	peak	
5		418.970	39.02	-9.34	29.68	46.00	-16.32	peak	
6		697.360	29.77	-3.54	26.23	46.00	-19.77	peak	

APPENDIX D - RADIATED EMISSION (ABOVE 1000MHZ)

Orthogonal Axis:	X
Test Mode:	UNII-1/ TX A Mode 5180MHz

Vertical

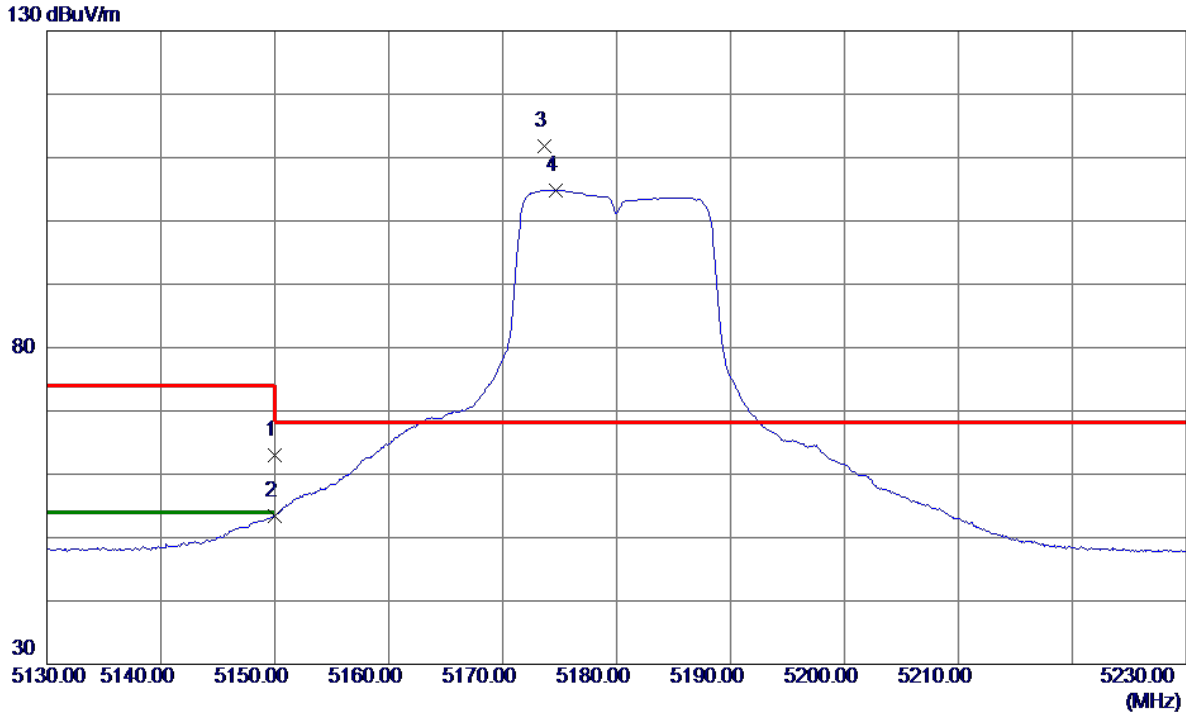

No.	Freq. MHz	Reading Level dBuV/m	Correct Factor dB	Measure ment dBuV/m	Limit dBuV/m	Margin dB	Detector	Comment
1	5150.0000	46.27	16.65	62.92	74.00	-11.08	Peak	
2	5150.0000	36.82	16.65	53.47	54.00	-0.53	AVG	
3 *	5173.7000	95.01	16.71	111.72	68.30	43.42	Peak	No Limit
4	5174.7000	88.11	16.72	104.83	999.00	-894.17	AVG	No Limit

Orthogonal Axis:	X
Test Mode:	UNII-1/ TX A Mode 5180MHz

Vertical

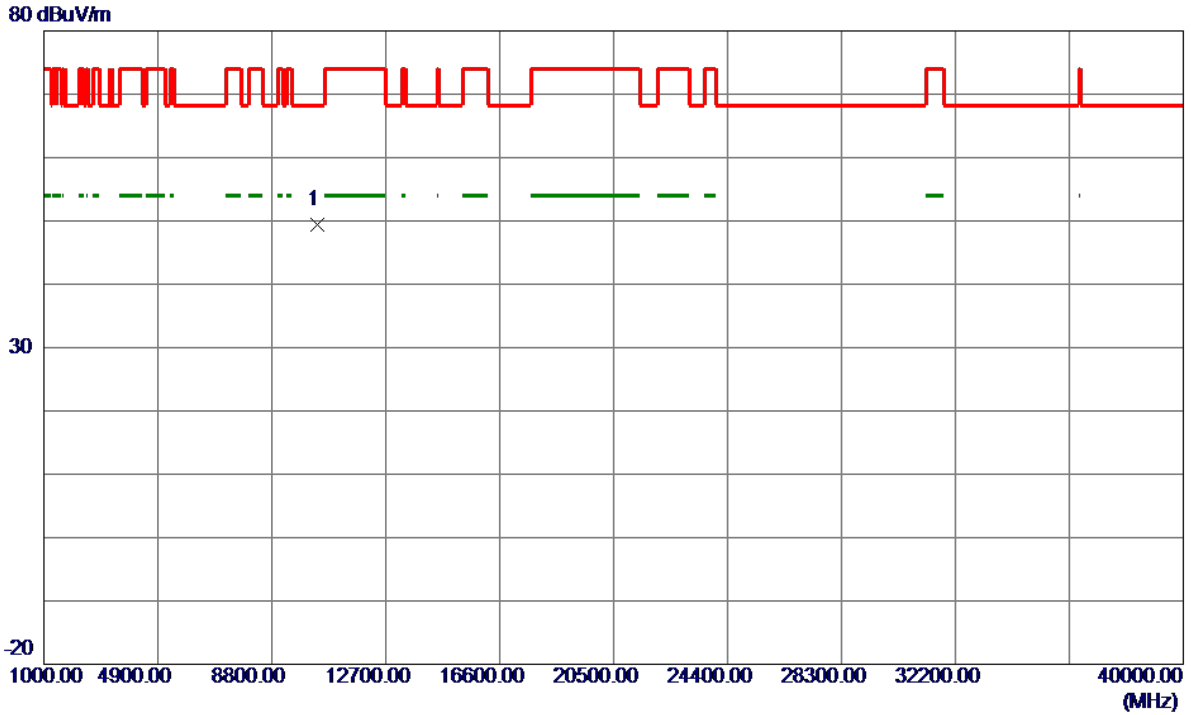

No.	Freq. MHz	Reading Level dBuV/m	Correct Factor dB	Measure ment dBuV/m	Limit dBuV/m	Margin dB	Detector	Comment
1 *	10356.6200	34.62	14.84	49.46	68.30	-18.84	Peak	

Orthogonal Axis:	X
Test Mode:	UNII-1/ TX A Mode 5180MHz

Horizontal

130 dBuV/m

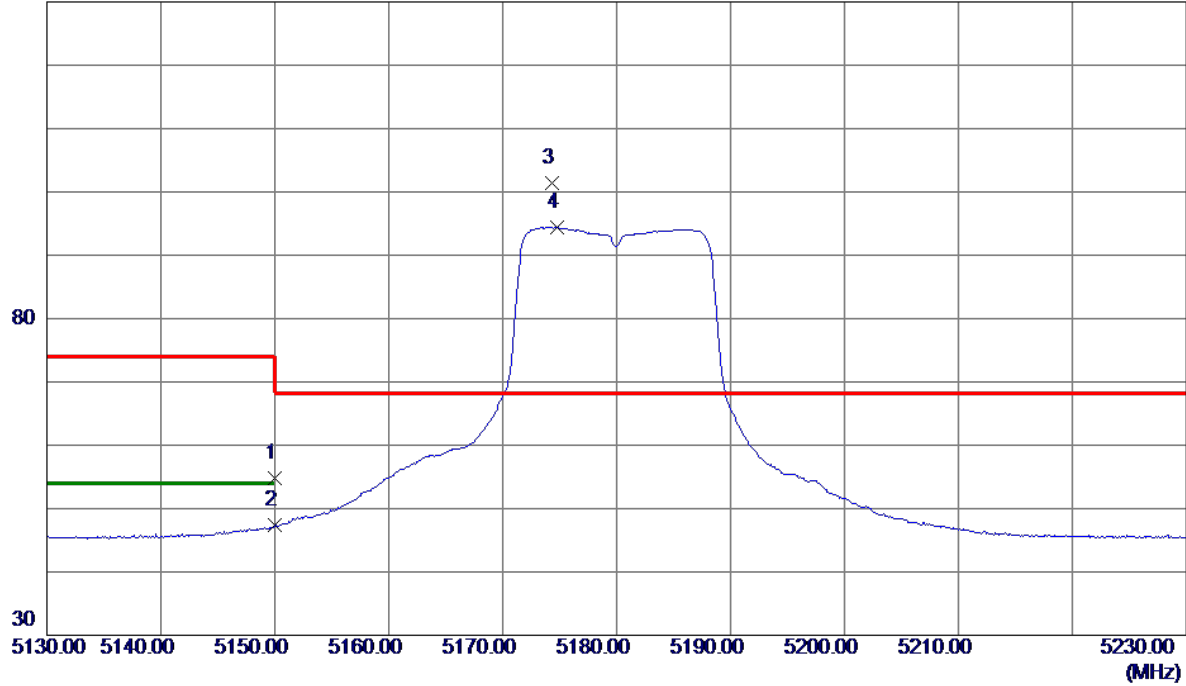

No.	Freq. MHz	Reading Level dBuV/m	Correct Factor dB	Measure ment dBuV/m	Limit dBuV/m	Margin dB	Detector	Comment
1	5150.0000	38.11	16.65	54.76	74.00	-19.24	Peak	
2	5150.0000	30.72	16.65	47.37	54.00	-6.63	AVG	
3 *	5174.3000	84.63	16.71	101.34	68.30	33.04	Peak	No Limit
4	5174.8000	77.66	16.72	94.38	999.00	-904.62	AVG	No Limit

Orthogonal Axis:	X
Test Mode:	UNII-1/ TX A Mode 5180MHz

Horizontal

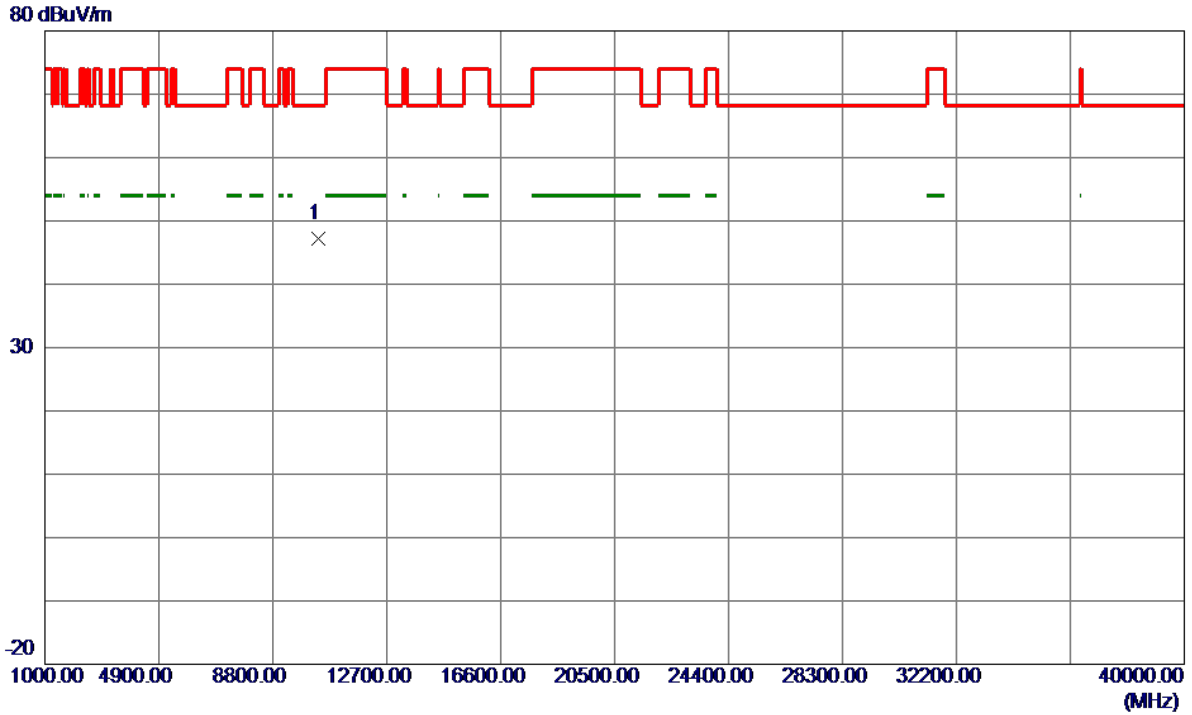

No.	Freq. MHz	Reading Level dBuV/m	Correct Factor dB	Measure ment dBuV/m	Limit dBuV/m	Margin dB	Detector	Comment
1 *	10359.2100	32.35	14.85	47.20	68.30	-21.10	Peak	

Orthogonal Axis:	X
Test Mode:	UNII-1/ TX A Mode 5200MHz

Vertical

130 dBuV/m

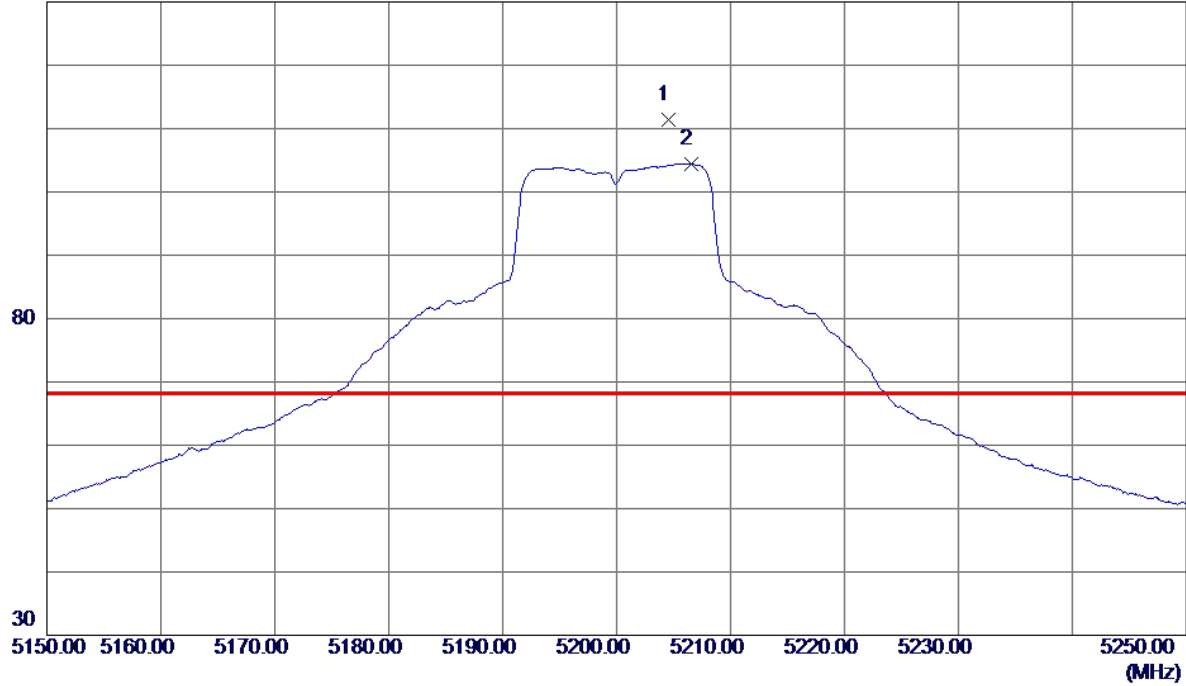

No.	Freq. MHz	Reading Level dBuV/m	Correct Factor dB	Measure ment dBuV/m	Limit dBuV/m	Margin dB	Detector	Comment
1 *	5204.5000	94.57	16.80	111.37	68.30	43.07	Peak	No Limit
2	5206.5000	87.62	16.81	104.43	999.00	-894.57	AVG	No Limit

Orthogonal Axis:	X
Test Mode:	UNII-1/ TX A Mode 5200MHz

Vertical

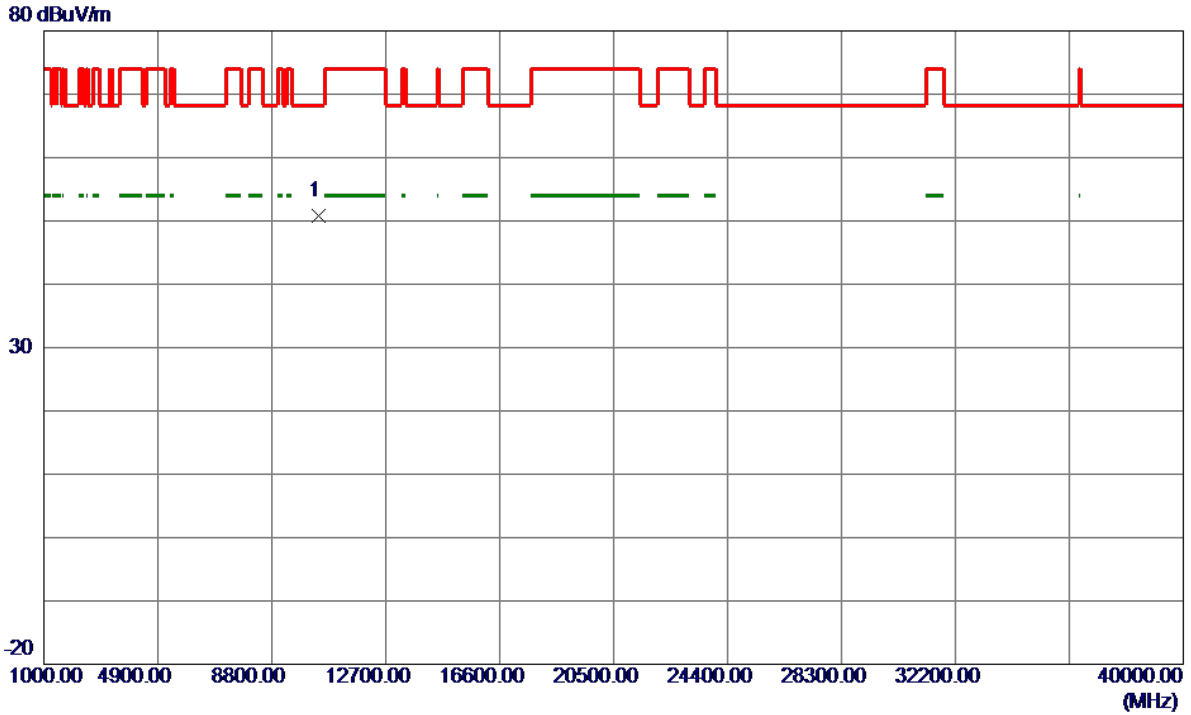

No.	Freq. MHz	Reading Level dBuV/m	Correct Factor dB	Measure ment dBuV/m	Limit dBuV/m	Margin dB	Detector	Comment
1 *	10400.1500	35.83	14.92	50.75	68.30	-17.55	Peak	

Orthogonal Axis:	X
Test Mode:	UNII-1/ TX A Mode 5200MHz

Horizontal

130 dBuV/m

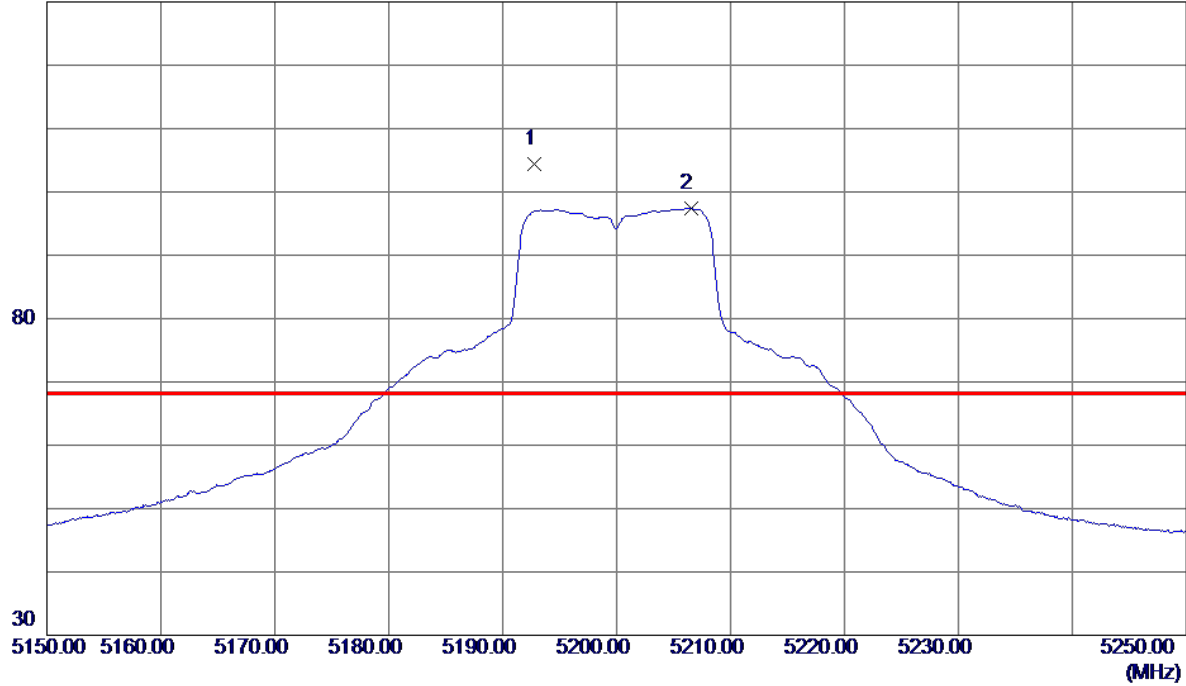

No.	Freq. MHz	Reading Level dBuV/m	Correct Factor dB	Measure ment dBuV/m	Limit dBuV/m	Margin dB	Detector	Comment
1 *	5192.8000	87.72	16.77	104.49	68.30	36.19	Peak	No Limit
2	5206.5000	80.53	16.81	97.34	999.00	-901.66	AVG	No Limit

Orthogonal Axis:	X
Test Mode:	UNII-1/ TX A Mode 5200MHz

Horizontal

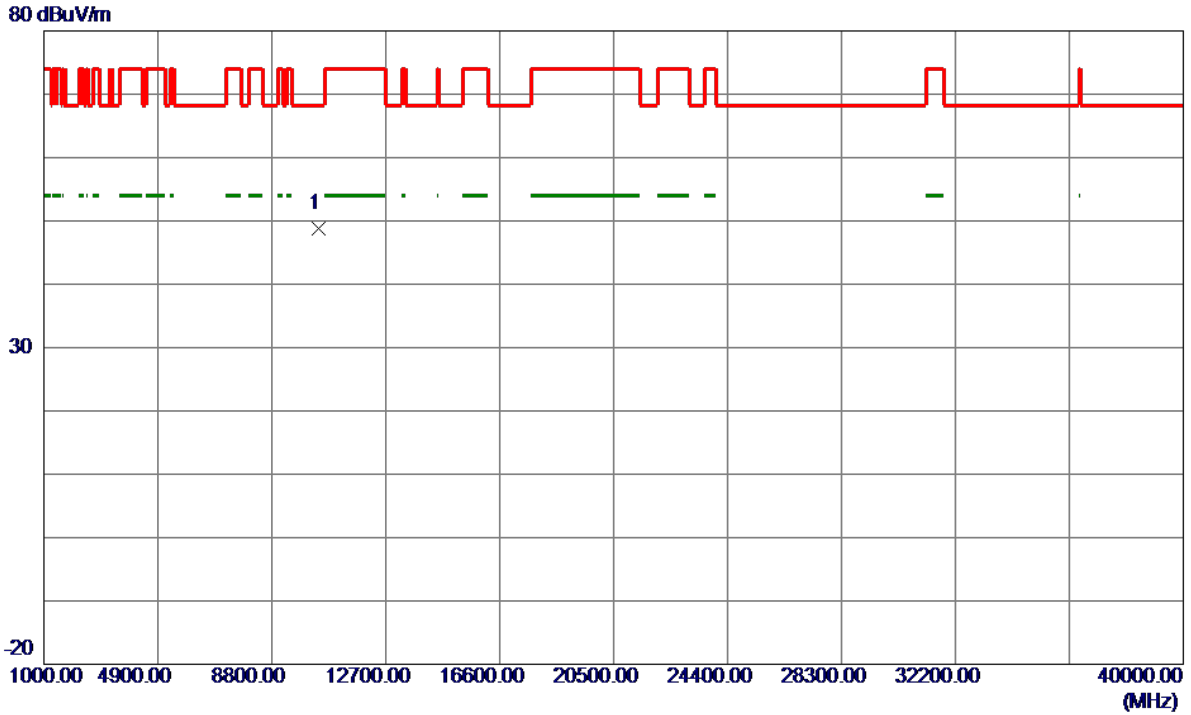

No.	Freq. MHz	Reading Level dBuV/m	Correct Factor dB	Measure ment dBuV/m	Limit dBuV/m	Margin dB	Detector	Comment
1 *	10397.6500	33.94	14.91	48.85	68.30	-19.45	Peak	

Orthogonal Axis:	X
Test Mode:	UNII-1/ TX A Mode 5240MHz

Vertical

130 dBuV/m

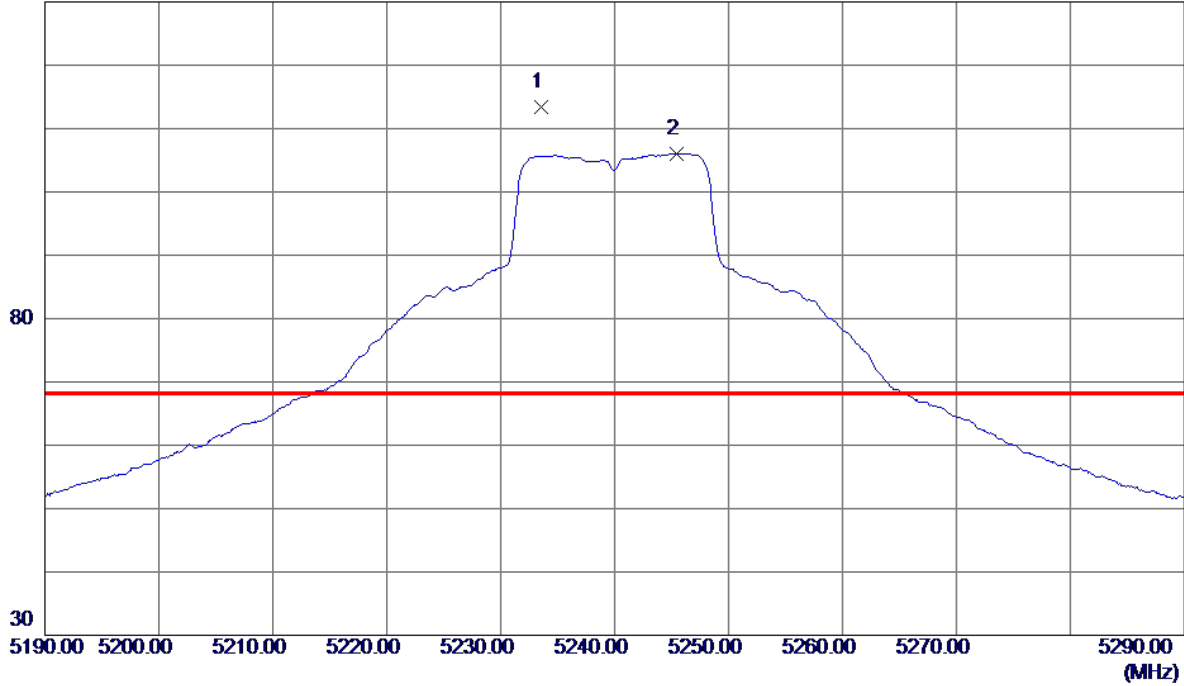

No.	Freq. MHz	Reading Level dBuV/m	Correct Factor dB	Measure ment dBuV/m	Limit dBuV/m	Margin dB	Detector	Comment
1 *	5233.6000	96.56	16.88	113.44	68.30	45.14	Peak	No Limit
2	5245.4000	89.13	16.92	106.05	999.00	-892.95	AVG	No Limit

Orthogonal Axis:	X
Test Mode:	UNII-1/ TX A Mode 5240MHz

Vertical

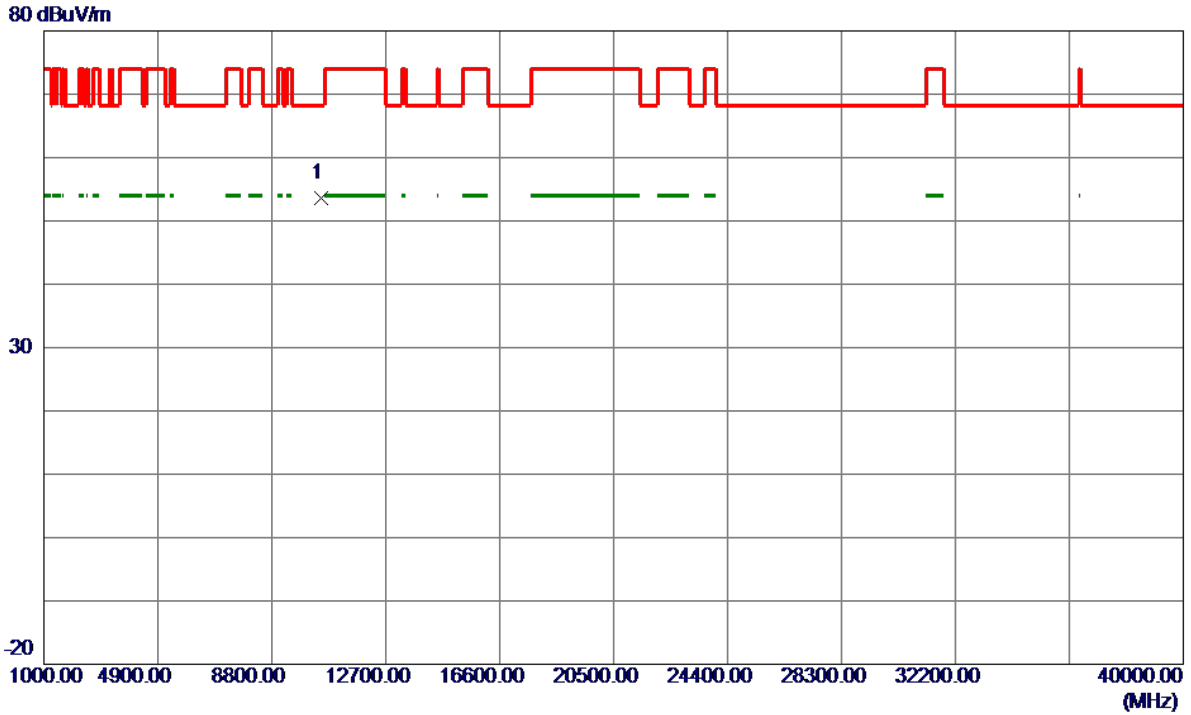

No.	Freq. MHz	Reading Level dBuV/m	Correct Factor dB	Measure ment dBuV/m	Limit dBuV/m	Margin dB	Detector	Comment
1 *	10480.2900	38.63	15.06	53.69	68.30	-14.61	Peak	

Orthogonal Axis:	X
Test Mode:	UNII-1/ TX A Mode 5240MHz

Horizontal

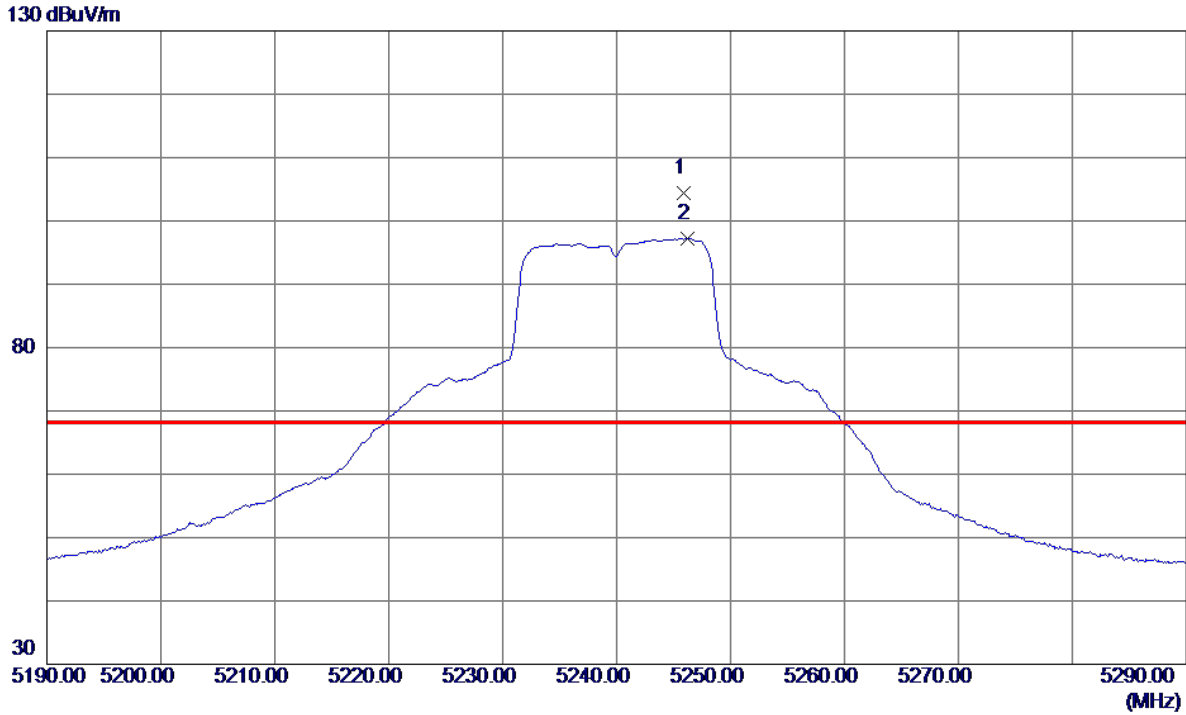

No.	Freq. MHz	Reading Level dBuV/m	Correct Factor dB	Measure ment dBuV/m	Limit dBuV/m	Margin dB	Detector	Comment
1 *	5245.9000	87.48	16.92	104.40	68.30	36.10	Peak	No Limit
2	5246.2000	80.23	16.92	97.15	999.00	-901.85	AVG	No Limit

Orthogonal Axis:	X
Test Mode:	UNII-1/ TX A Mode 5240MHz

Horizontal

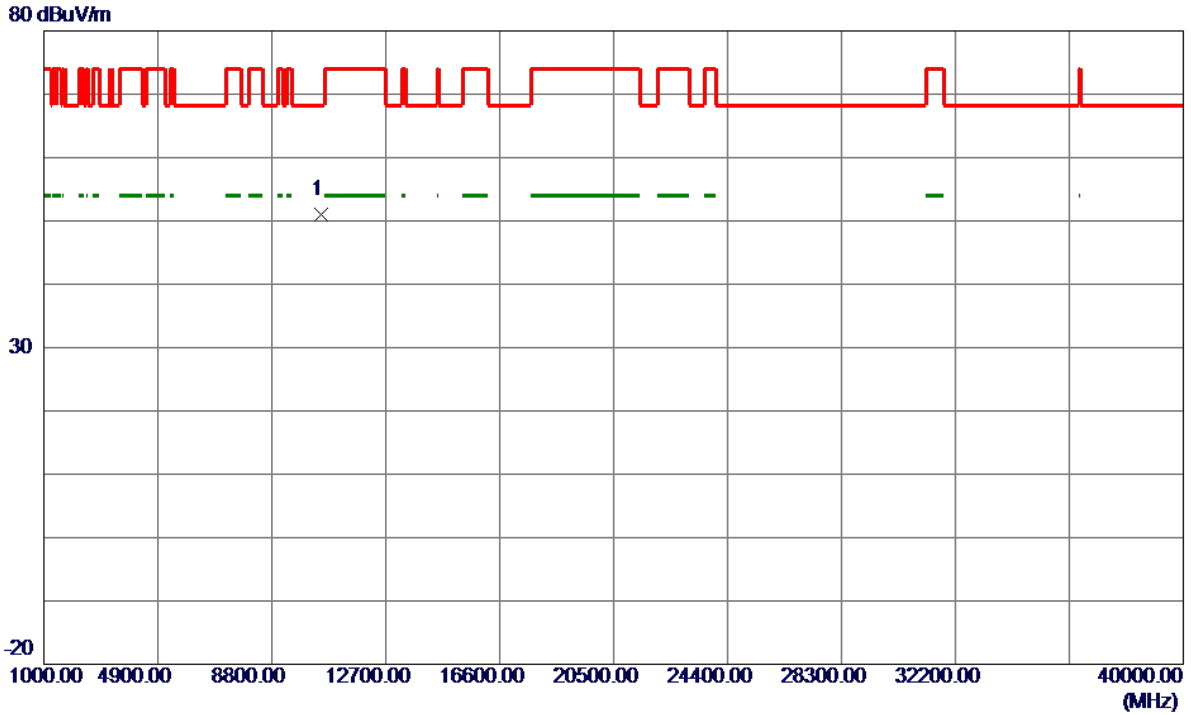

No.	Freq. MHz	Reading Level dBuV/m	Correct Factor dB	Measure ment dBuV/m	Limit dBuV/m	Margin dB	Detector	Comment
1 *	10481.5400	36.01	15.06	51.07	68.30	-17.23	Peak	

Orthogonal Axis:	X
Test Mode:	UNII-1/ TX N20 Mode 5180MHz

Vertical

130 dBuV/m

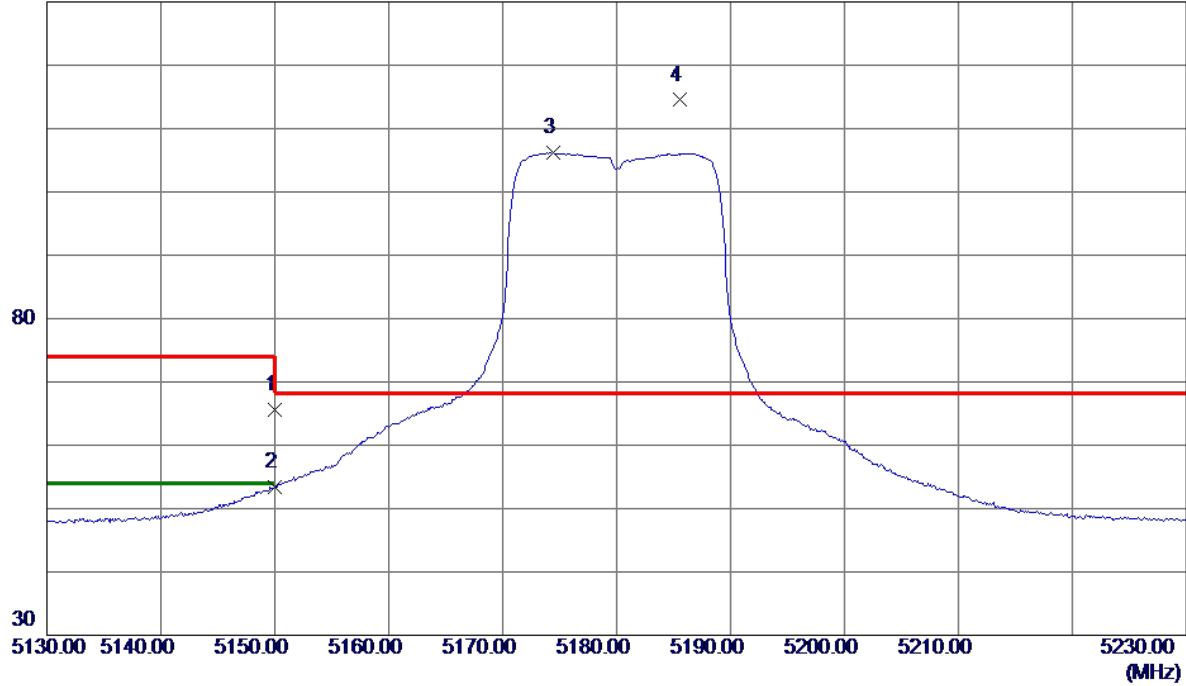

No.	Freq. MHz	Reading Level dBuV/m	Correct Factor dB	Measure ment dBuV/m	Limit dBuV/m	Margin dB	Detector	Comment
1	5150.0000	49.04	16.65	65.69	74.00	-8.31	Peak	
2	5150.0000	36.84	16.65	53.49	54.00	-0.51	AVG	
3	5174.4000	89.47	16.72	106.19	999.00	-892.81	AVG	No Limit
4 *	5185.6000	97.75	16.75	114.50	68.30	46.20	Peak	No Limit

Orthogonal Axis:	X
Test Mode:	UNII-1/ TX N20 Mode 5180MHz

Vertical

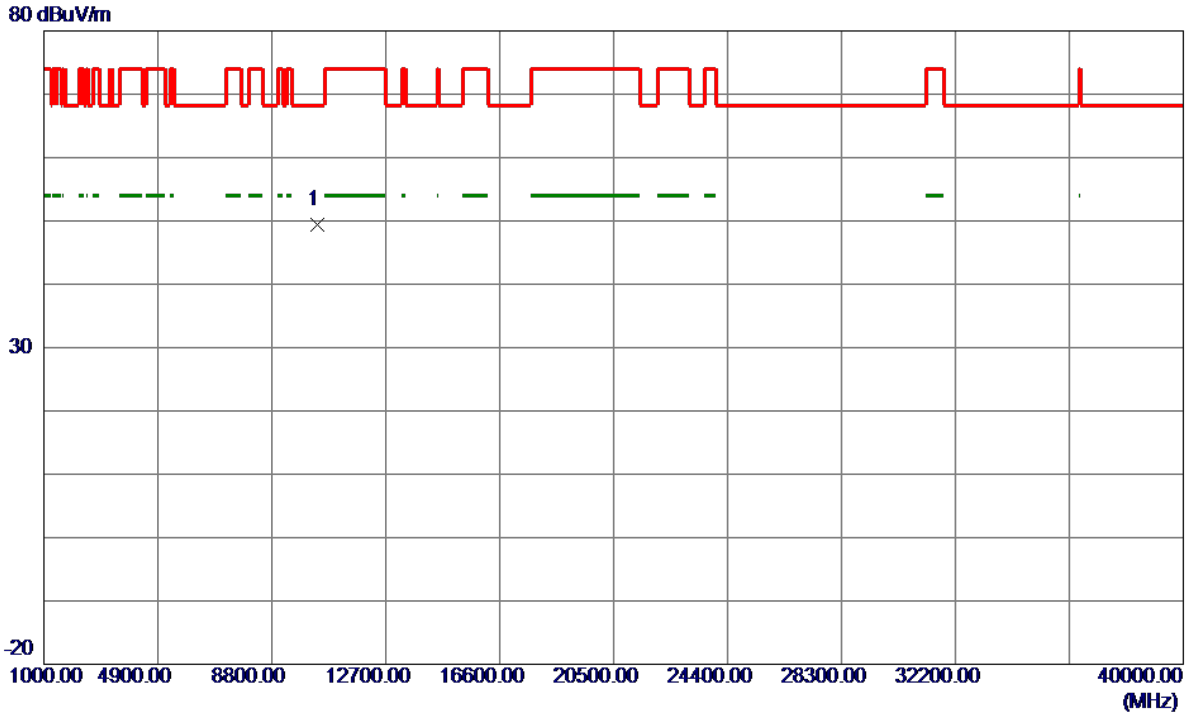

No.	Freq. MHz	Reading Level dBuV/m	Correct Factor dB	Measure ment dBuV/m	Limit dBuV/m	Margin dB	Detector	Comment
1 *	10363.9000	34.47	14.85	49.32	68.30	-18.98	Peak	

Orthogonal Axis:	X
Test Mode:	UNII-1/ TX N20 Mode 5180MHz

Horizontal

130 dBuV/m

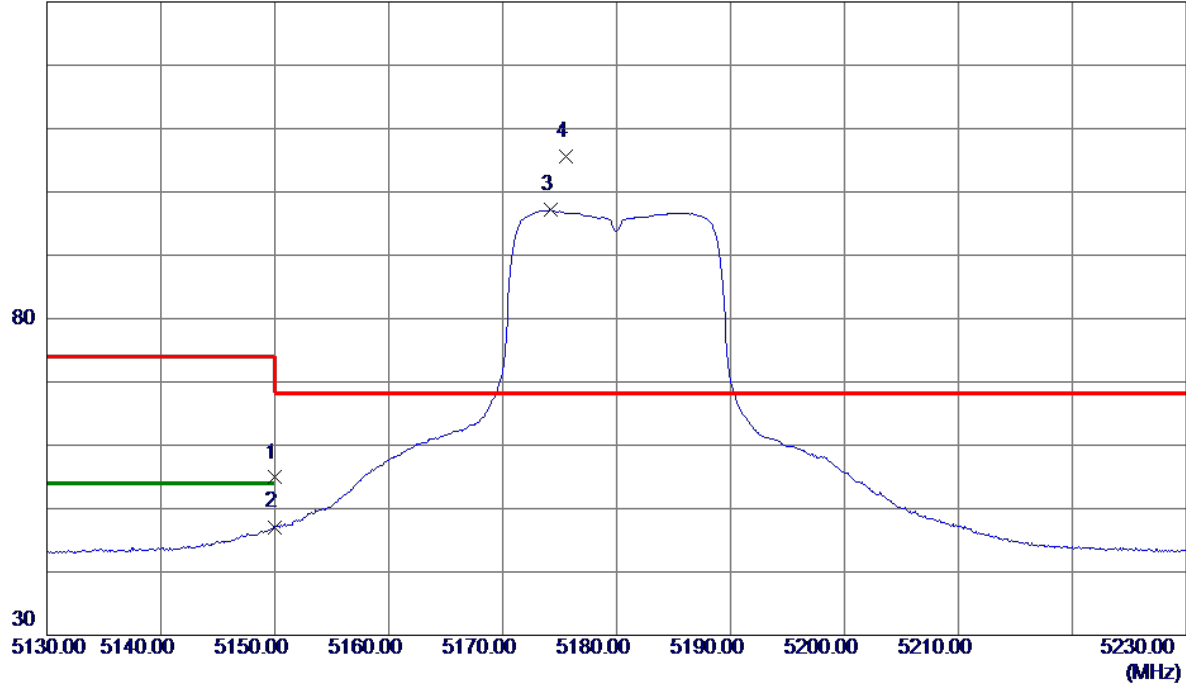

No.	Freq. MHz	Reading Level dBuV/m	Correct Factor dB	Measure ment dBuV/m	Limit dBuV/m	Margin dB	Detector	Comment
1	5150.0000	38.25	16.65	54.90	74.00	-19.10	Peak	
2	5150.0000	30.45	16.65	47.10	54.00	-6.90	AVG	
3	5174.2000	80.42	16.71	97.13	999.00	-901.87	AVG	No Limit
4 *	5175.6000	88.92	16.72	105.64	68.30	37.34	Peak	No Limit

Orthogonal Axis:	X
Test Mode:	UNII-1/ TX N20 Mode 5180MHz

Horizontal

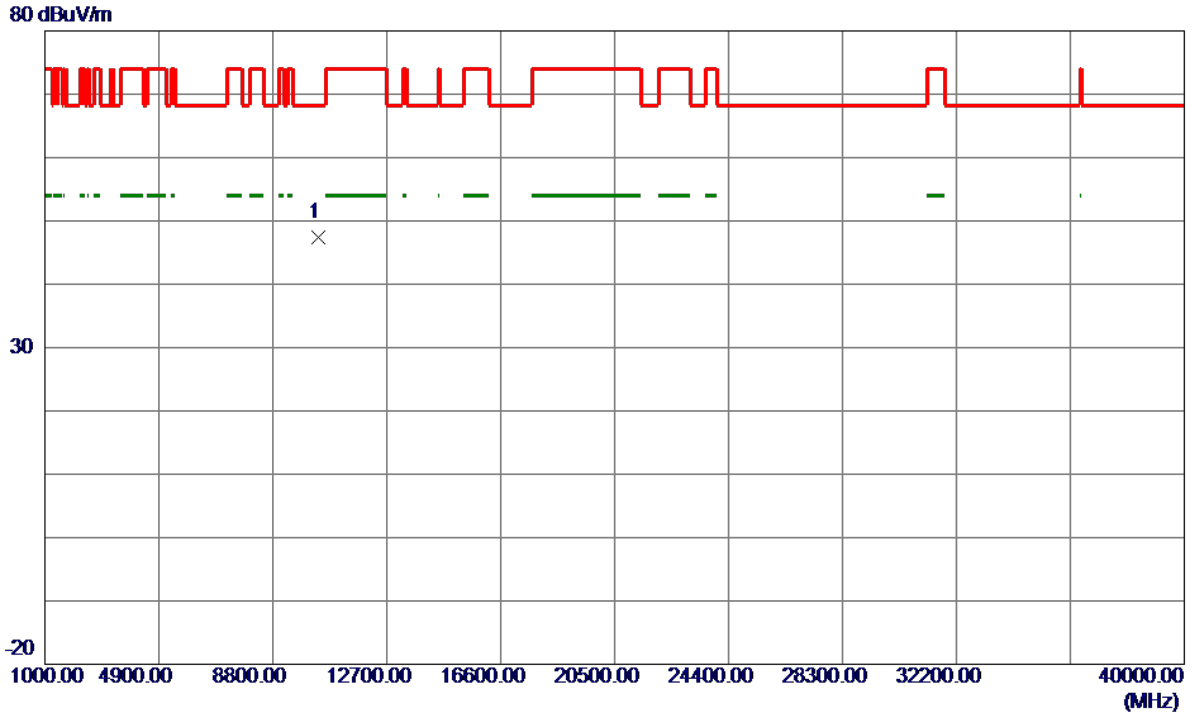

No.	Freq. MHz	Reading Level dBuV/m	Correct Factor dB	Measure ment dBuV/m	Limit dBuV/m	Margin dB	Detector	Comment
1 *	10363.2500	32.62	14.85	47.47	68.30	-20.83	Peak	

Orthogonal Axis:	X
Test Mode:	UNII-1/ TX N20 Mode 5200MHz

Vertical

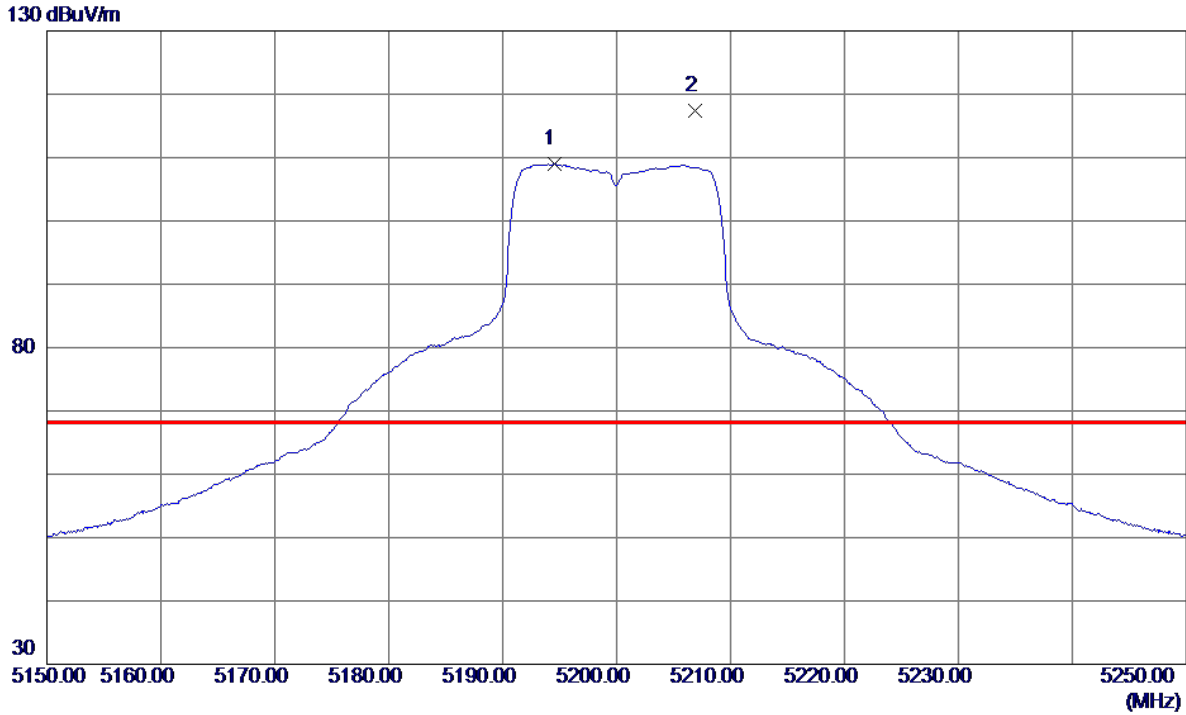

No.	Freq. MHz	Reading Level dBuV/m	Correct Factor dB	Measure ment dBuV/m	Limit dBuV/m	Margin dB	Detector	Comment
1	5194.5000	92.18	16.77	108.95	999.00	-890.05	AVG	No Limit
2 *	5206.9000	100.67	16.81	117.48	68.30	49.18	Peak	No Limit

Orthogonal Axis:	X
Test Mode:	UNII-1/ TX N20 Mode 5200MHz

Vertical

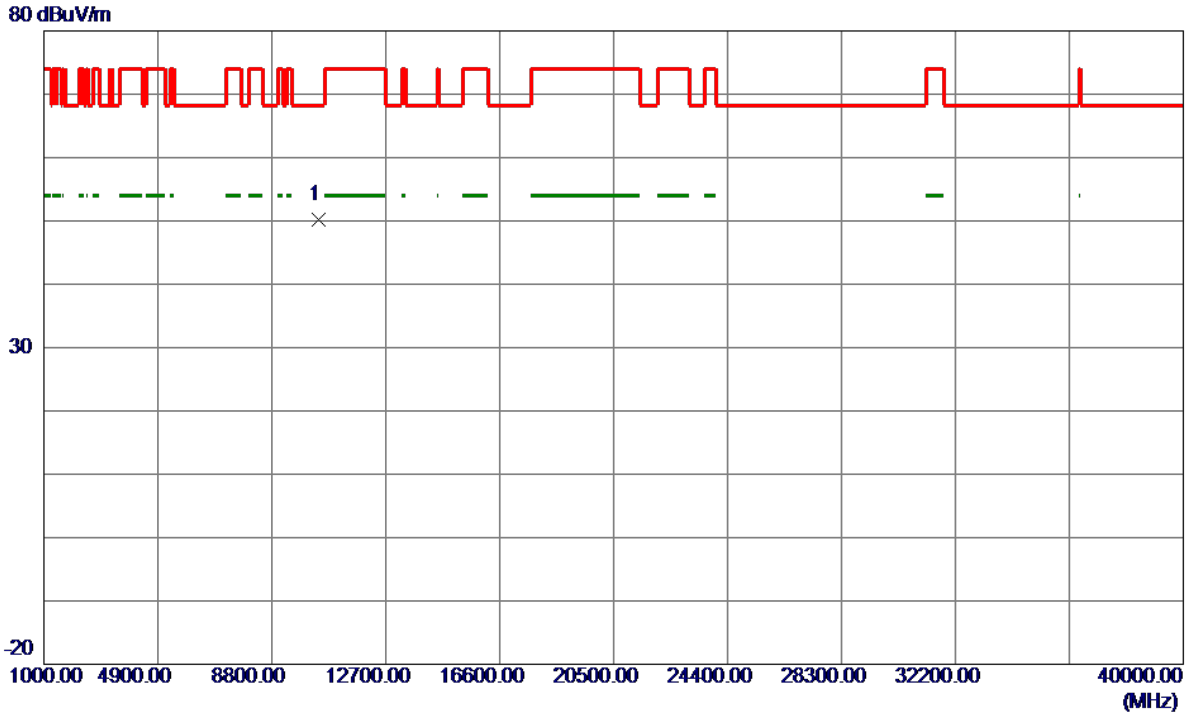

No.	Freq. MHz	Reading Level dBuV/m	Correct Factor dB	Measure ment dBuV/m	Limit dBuV/m	Margin dB	Detector	Comment
1 *	10410.8500	35.17	14.94	50.11	68.30	-18.19	Peak	

Orthogonal Axis:	X
Test Mode:	UNII-1/ TX N20 Mode 5200MHz

Horizontal

130 dBuV/m

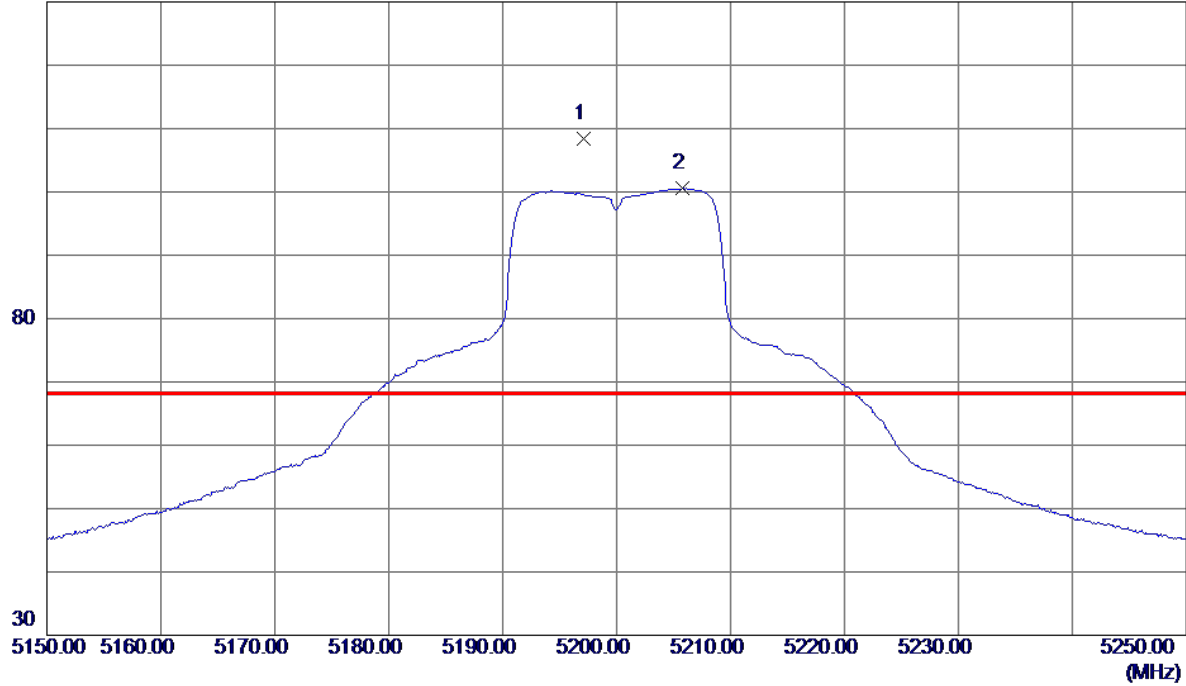

No.	Freq. MHz	Reading Level dBuV/m	Correct Factor dB	Measure ment dBuV/m	Limit dBuV/m	Margin dB	Detector	Comment
1 *	5197.1000	91.57	16.78	108.35	68.30	40.05	Peak	No Limit
2	5205.8000	83.72	16.80	100.52	999.00	-898.48	AVG	No Limit

Orthogonal Axis:	X
Test Mode:	UNII-1/ TX N20 Mode 5200MHz

Horizontal

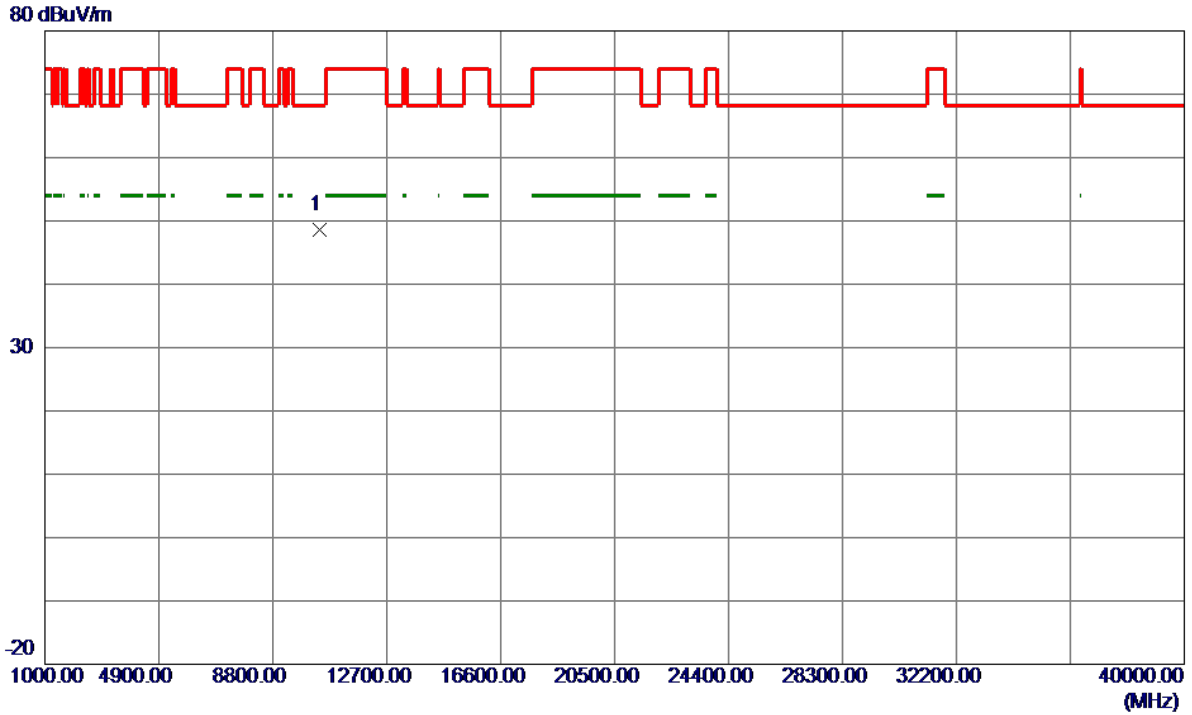

No.	Freq. MHz	Reading Level dBuV/m	Correct Factor dB	Measure ment dBuV/m	Limit dBuV/m	Margin dB	Detector	Comment
1 *	10410.1500	33.61	14.94	48.55	68.30	-19.75	Peak	

Orthogonal Axis:	X
Test Mode:	UNII-1/ TX N20 Mode 5240MHz

Vertical

130 dBuV/m

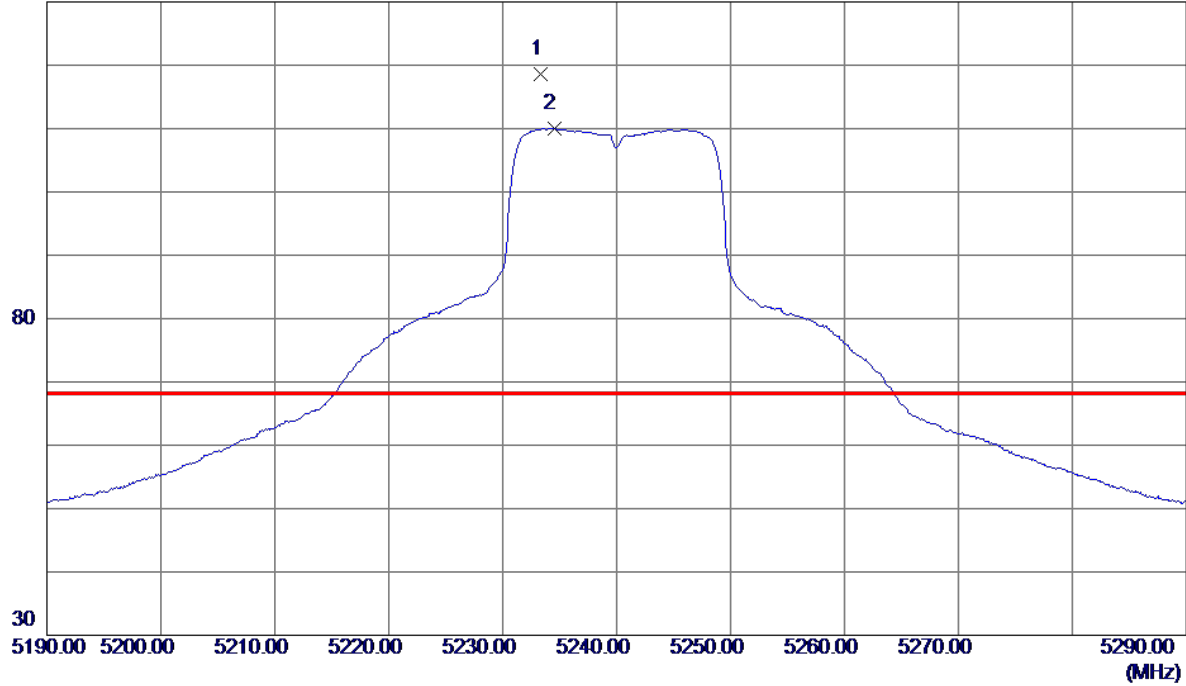

No.	Freq. MHz	Reading Level dBuV/m	Correct Factor dB	Measure ment dBuV/m	Limit dBuV/m	Margin dB	Detector	Comment
1 *	5233.3000	101.65	16.88	118.53	68.30	50.23	Peak	No Limit
2	5234.5000	93.09	16.89	109.98	999.00	-889.02	AVG	No Limit

Orthogonal Axis:	X
Test Mode:	UNII-1/ TX N20 Mode 5240MHz

Vertical

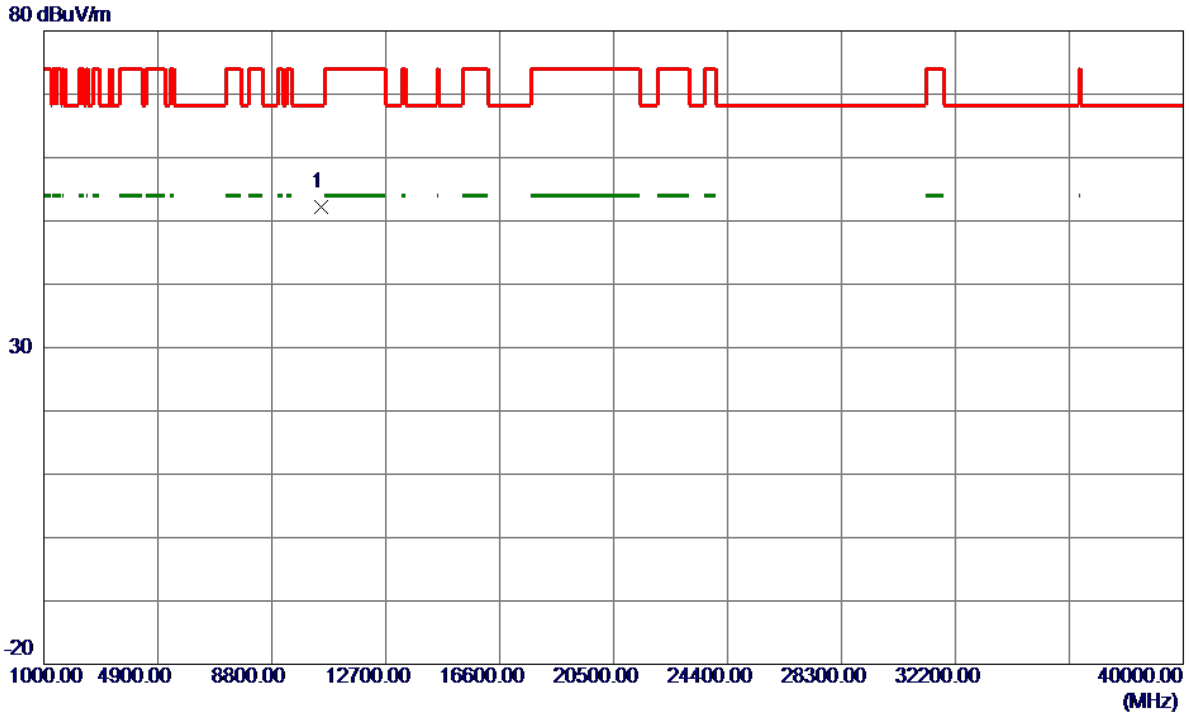

No.	Freq. MHz	Reading Level dBuV/m	Correct Factor dB	Measure ment dBuV/m	Limit dBuV/m	Margin dB	Detector	Comment
1 *	10480.6000	37.23	15.06	52.29	68.30	-16.01	Peak	

Orthogonal Axis:	X
Test Mode:	UNII-1/ TX N20 Mode 5240MHz

Horizontal

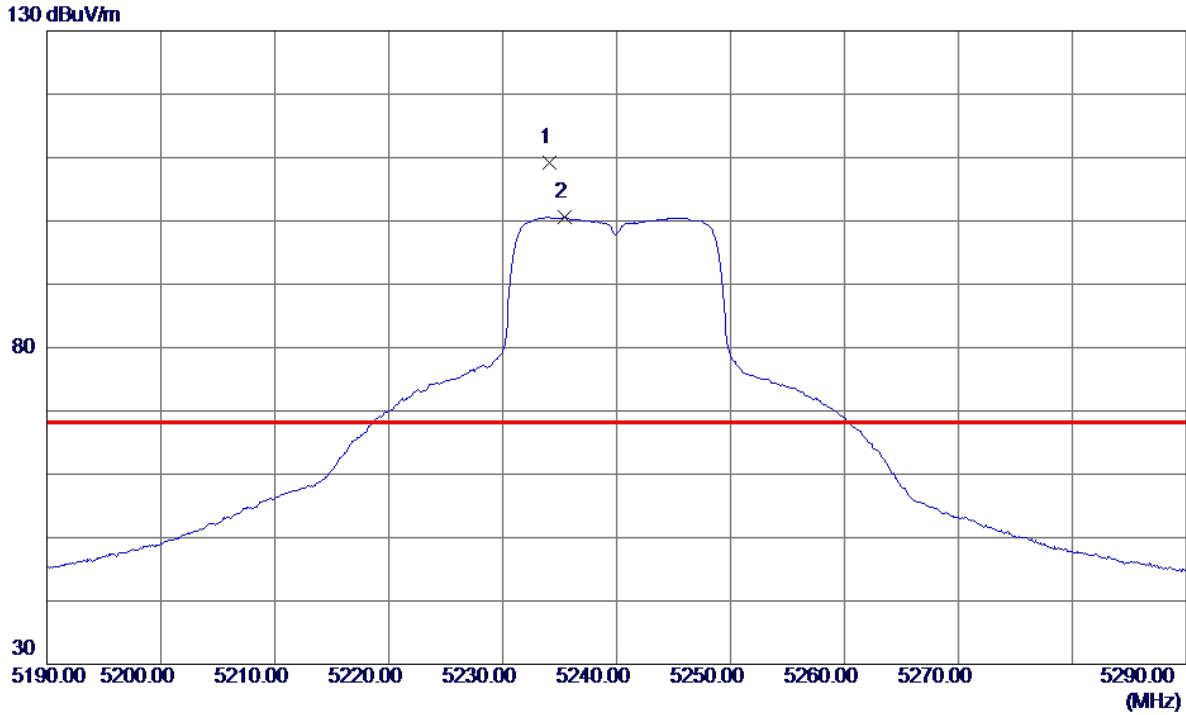

No.	Freq. MHz	Reading Level dBuV/m	Correct Factor dB	Measure ment dBuV/m	Limit dBuV/m	Margin dB	Detector	Comment
1 *	5234.1000	92.36	16.88	109.24	68.30	40.94	Peak	No Limit
2	5235.4000	83.72	16.89	100.61	999.00	-898.39	AVG	No Limit

Orthogonal Axis:	X
Test Mode:	UNII-1/ TX N20 Mode 5240MHz

Horizontal

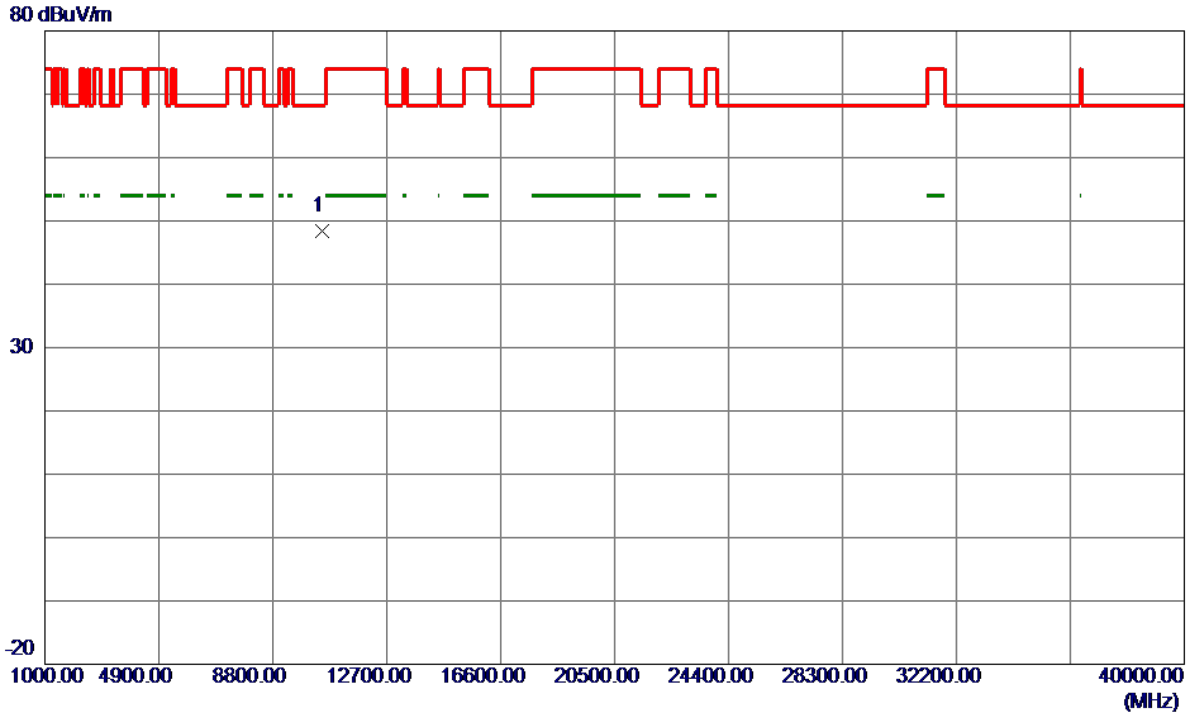

No.	Freq. MHz	Reading Level dBuV/m	Correct Factor dB	Measure ment dBuV/m	Limit dBuV/m	Margin dB	Detector	Comment
1 *	10487.1000	33.35	15.07	48.42	68.30	-19.88	Peak	

Orthogonal Axis:	X
Test Mode:	UNII-1/ TX N40 Mode 5190MHz

Vertical

130 dBuV/m

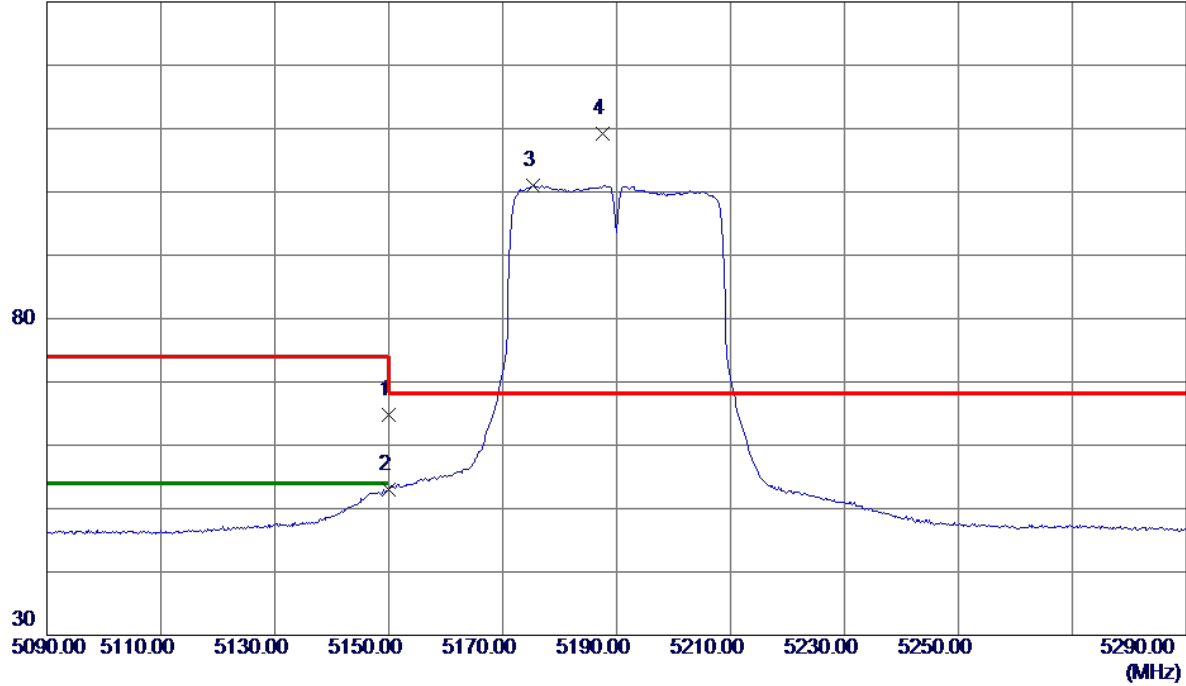

No.	Freq. MHz	Reading Level dBuV/m	Correct Factor dB	Measure ment dBuV/m	Limit dBuV/m	Margin dB	Detector	Comment
1	5150.0000	48.08	16.65	64.73	74.00	-9.27	Peak	
2	5150.0000	36.44	16.65	53.09	54.00	-0.91	AVG	
3	5175.4000	84.32	16.72	101.04	999.00	-897.96	AVG	No Limit
4 *	5187.6000	92.54	16.75	109.29	68.30	40.99	Peak	No Limit

Orthogonal Axis:	X
Test Mode:	UNII-1/ TX N40 Mode 5190MHz

Vertical

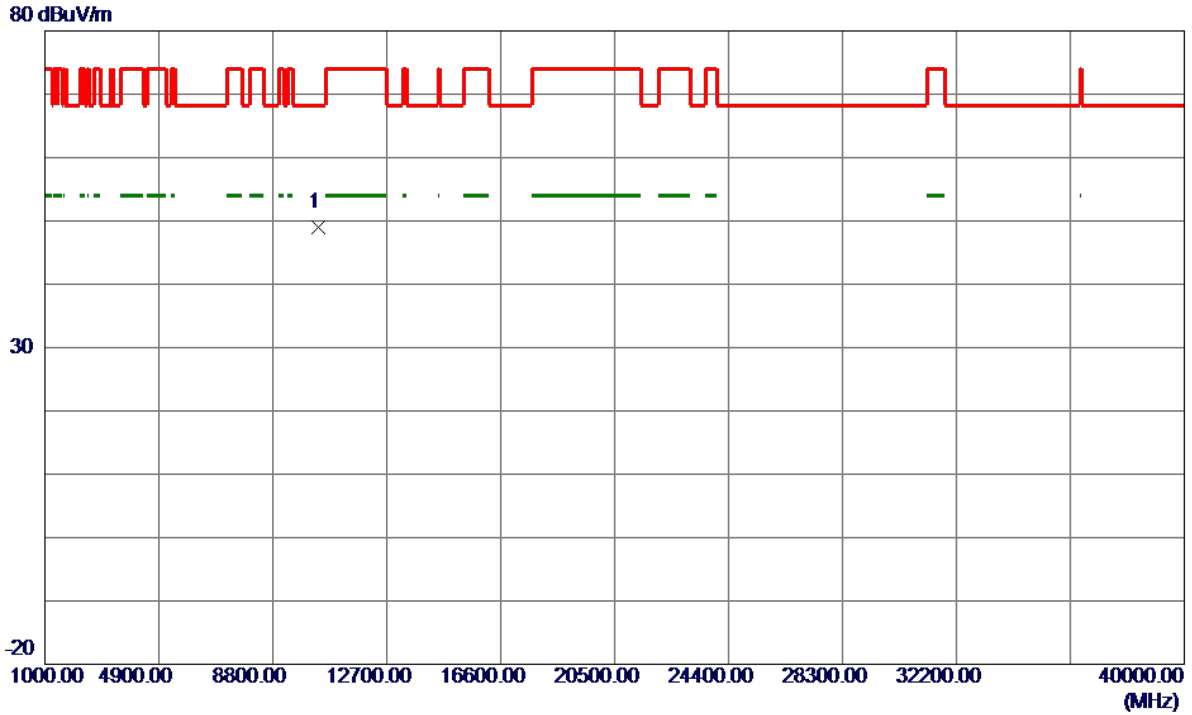

No.	Freq. MHz	Reading Level dBuV/m	Correct Factor dB	Measure ment dBuV/m	Limit dBuV/m	Margin dB	Detector	Comment
1 *	10376.6000	34.03	14.88	48.91	68.30	-19.39	Peak	

Orthogonal Axis:	X
Test Mode:	UNII-1/ TX N40 Mode 5190MHz

Horizontal

130 dBuV/m

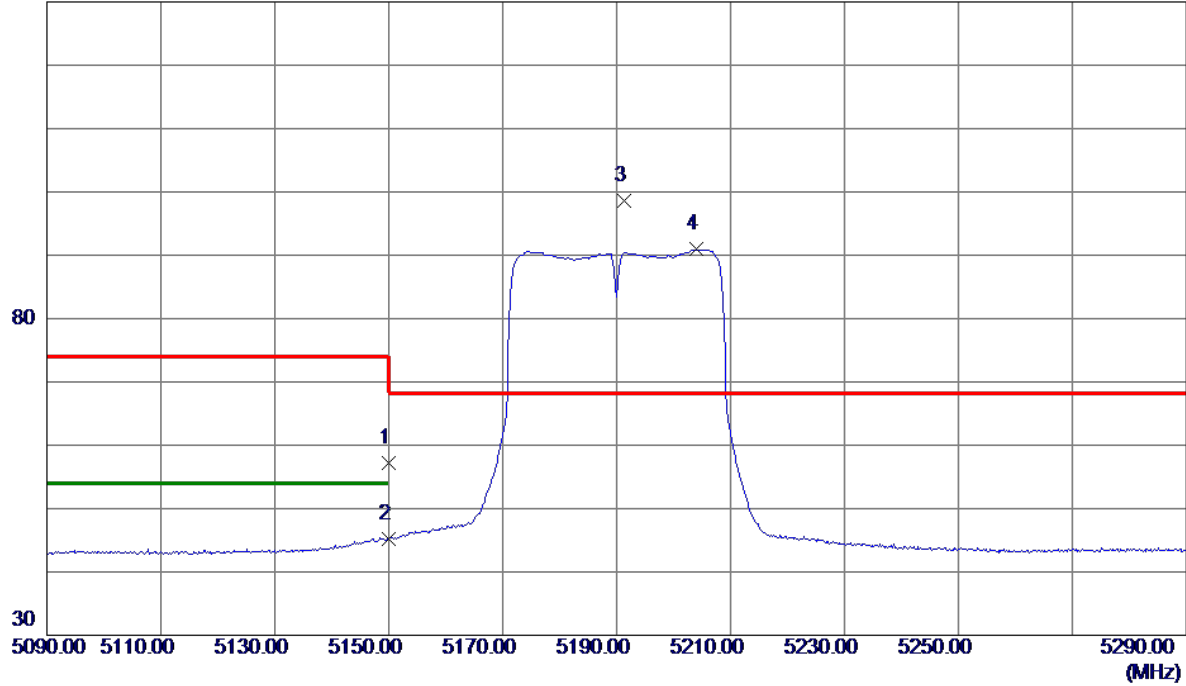

No.	Freq. MHz	Reading Level dBuV/m	Correct Factor dB	Measure ment dBuV/m	Limit dBuV/m	Margin dB	Detector	Comment
1	5150.0000	40.56	16.65	57.21	74.00	-16.79	Peak	
2	5150.0000	28.64	16.65	45.29	54.00	-8.71	AVG	
3 *	5191.4000	81.89	16.76	98.65	68.30	30.35	Peak	No Limit
4	5204.0000	74.10	16.80	90.90	999.00	-908.10	AVG	No Limit

Orthogonal Axis:	X
Test Mode:	UNII-1/ TX N40 Mode 5190MHz

Horizontal

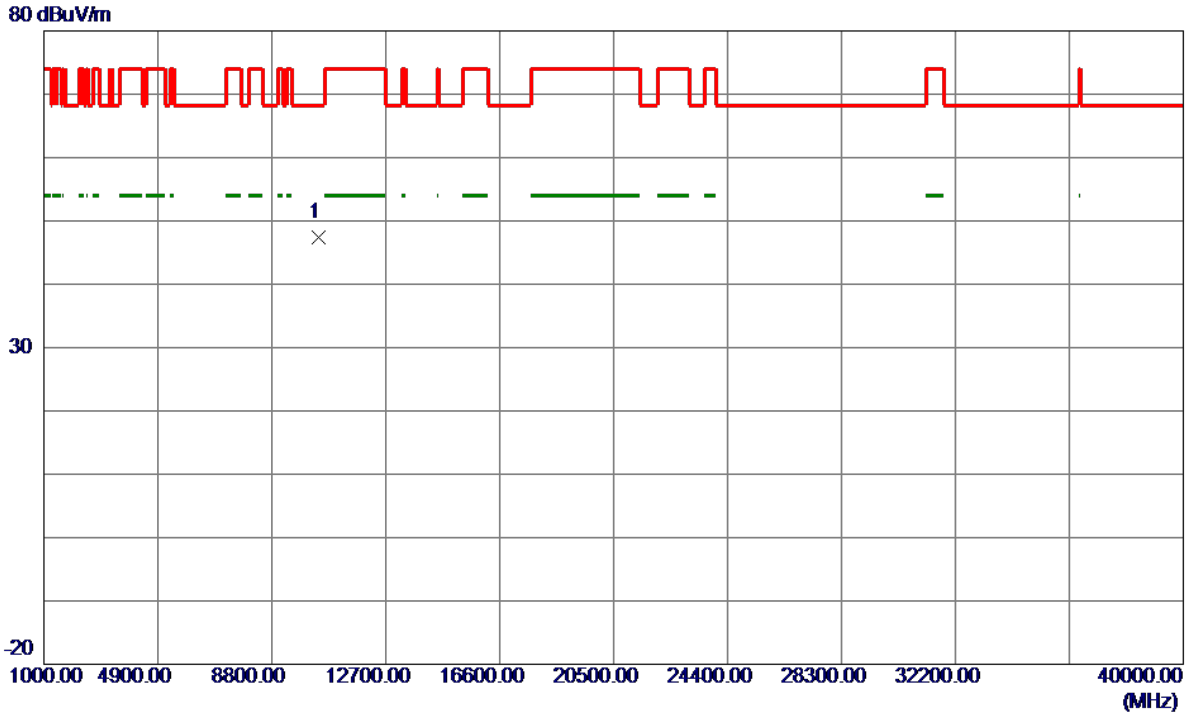

No.	Freq. MHz	Reading Level dBuV/m	Correct Factor dB	Measure ment dBuV/m	Limit dBuV/m	Margin dB	Detector	Comment
1 *	10398.8000	32.52	14.92	47.44	68.30	-20.86	Peak	

Orthogonal Axis:	X
Test Mode:	UNII-1/ TX N40 Mode 5230MHz

Vertical

130 dBuV/m

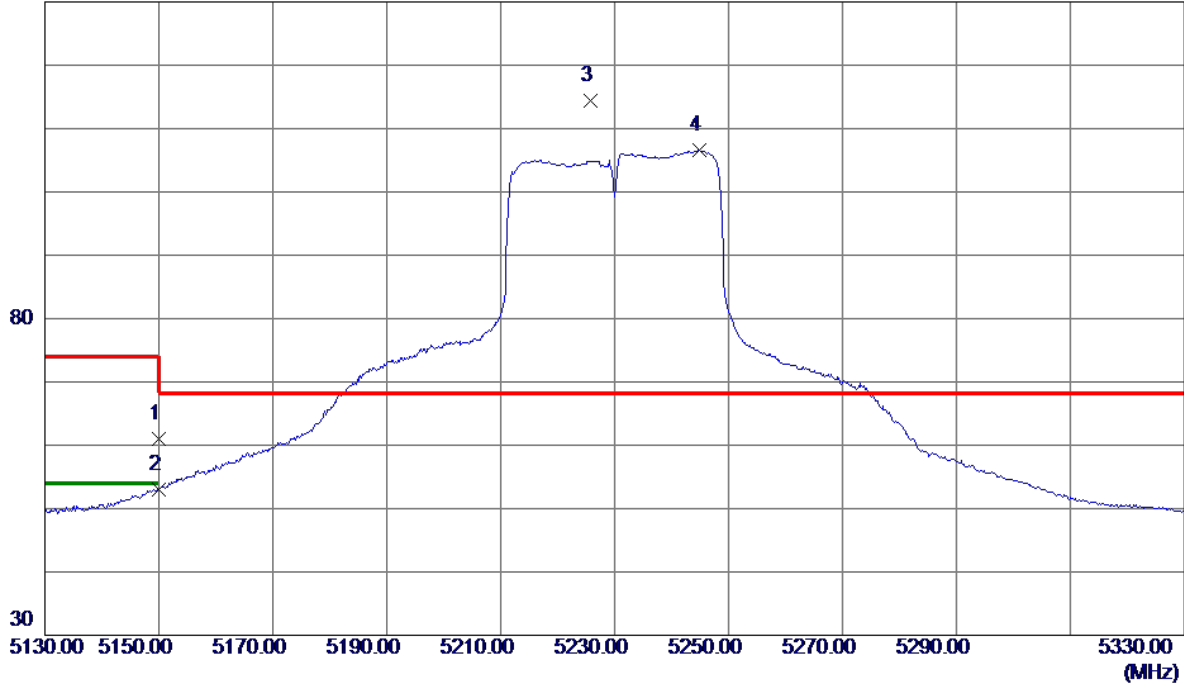

No.	Freq. MHz	Reading Level dBuV/m	Correct Factor dB	Measure ment dBuV/m	Limit dBuV/m	Margin dB	Detector	Comment
1	5150.0000	44.30	16.65	60.95	74.00	-13.05	Peak	
2	5150.0000	36.38	16.65	53.03	54.00	-0.97	AVG	
3 *	5225.8000	97.56	16.86	114.42	68.30	46.12	Peak	No Limit
4	5244.8000	89.64	16.92	106.56	999.00	-892.44	AVG	No Limit

Orthogonal Axis:	X
Test Mode:	UNII-1/ TX N40 Mode 5230MHz

Vertical

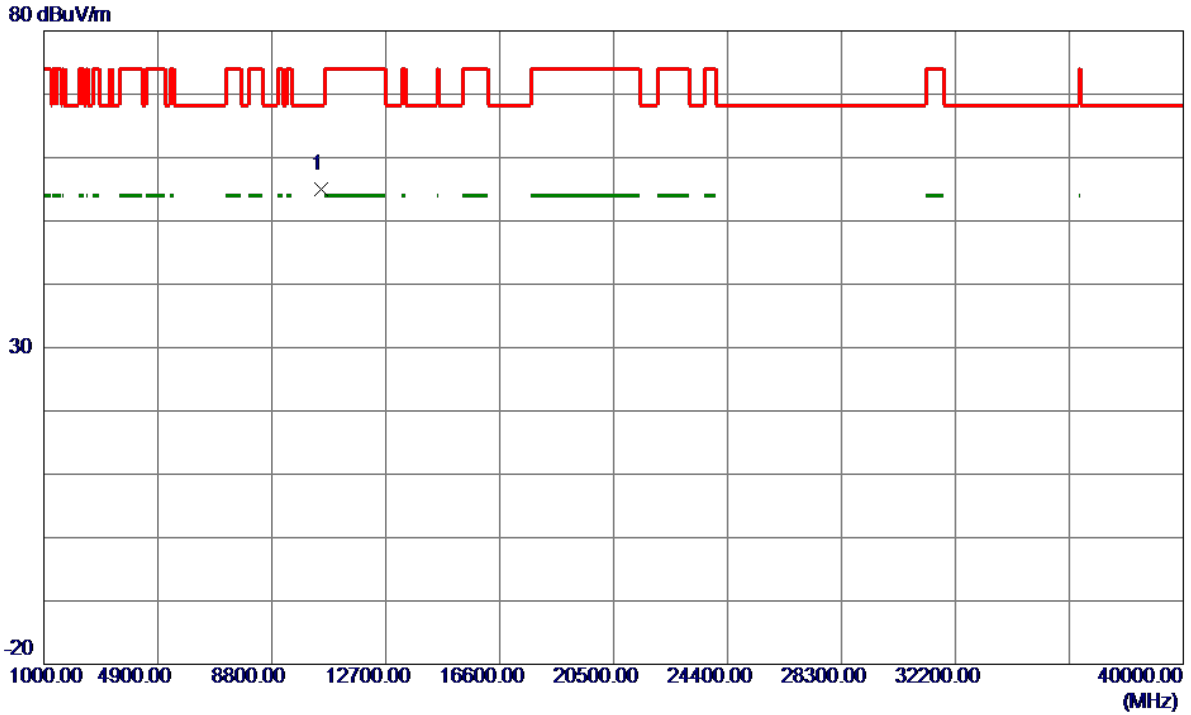

No.	Freq. MHz	Reading Level dBuV/m	Correct Factor dB	Measure ment dBuV/m	Limit dBuV/m	Margin dB	Detector	Comment
1 *	10471.0500	40.05	15.04	55.09	68.30	-13.21	Peak	

Orthogonal Axis:	X
Test Mode:	UNII-1/ TX N40 Mode 5230MHz

Horizontal

130 dBuV/m

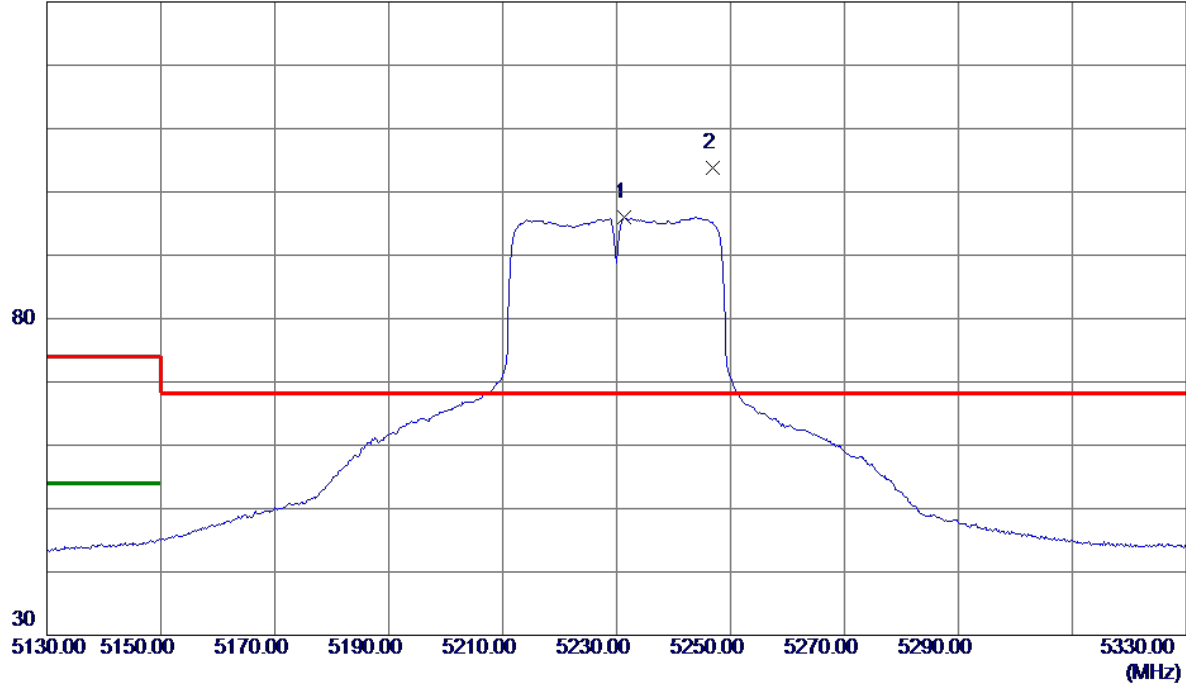

No.	Freq. MHz	Reading Level dBuV/m	Correct Factor dB	Measure ment dBuV/m	Limit dBuV/m	Margin dB	Detector	Comment
1	5231.4000	79.06	16.88	95.94	999.00	-903.06	AVG	No Limit
2 *	5246.8000	86.96	16.92	103.88	68.30	35.58	Peak	No Limit

Orthogonal Axis:	X
Test Mode:	UNII-1/ TX N40 Mode 5230MHz

Horizontal

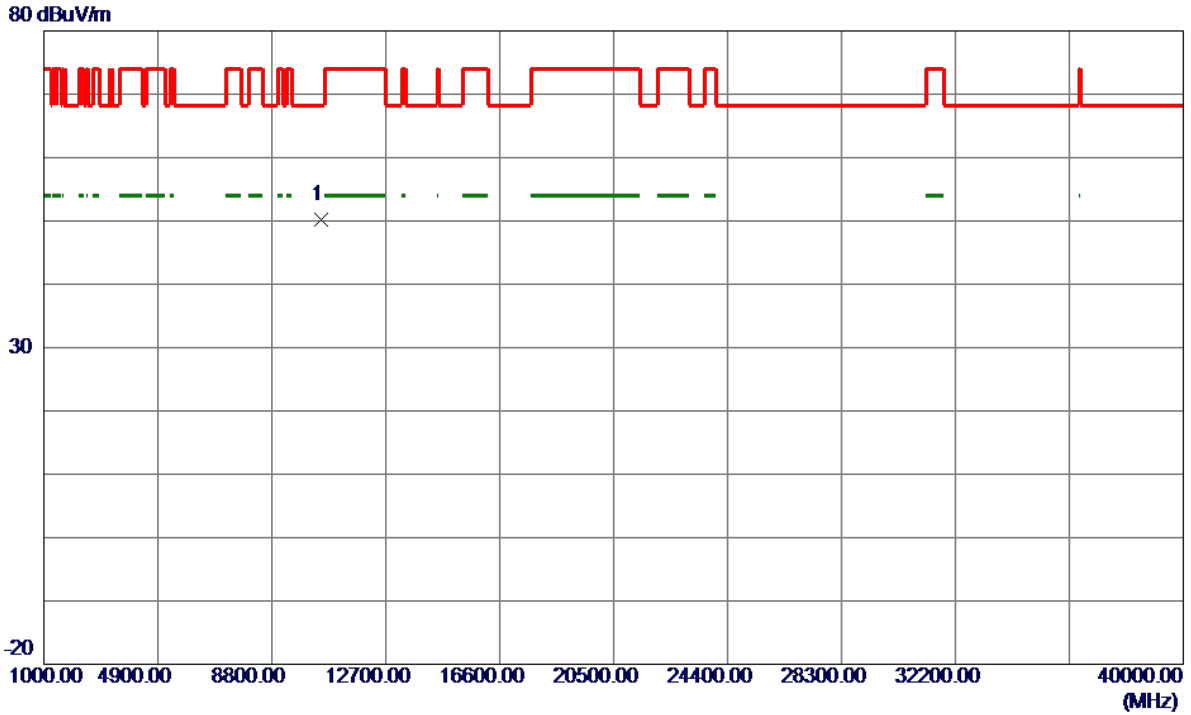

No.	Freq. MHz	Reading Level dBuV/m	Correct Factor dB	Measure ment dBuV/m	Limit dBuV/m	Margin dB	Detector	Comment
1 *	10471.1000	35.20	15.04	50.24	68.30	-18.06	Peak	

Orthogonal Axis:	X
Test Mode:	UNII-3/TX A Mode 5745MHz

Vertical

130 dBuV/m

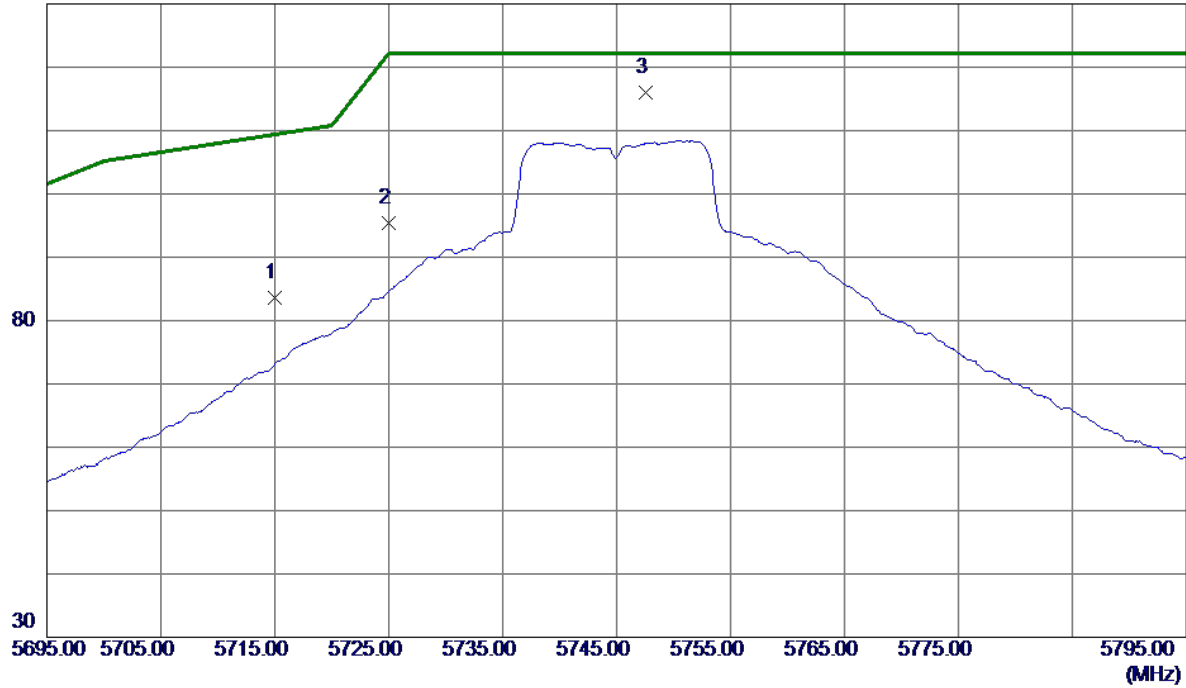

No.	Freq. MHz	Reading Level dBuV/m	Correct Factor dB	Measure ment dBuV/m	Limit dBuV/m	Margin dB	Detector	Comment
1	5715.0000	65.18	18.40	83.58	109.40	-25.82	Peak	
2	5725.0000	77.00	18.44	95.44	122.20	-26.76	Peak	
3 *	5747.6000	97.57	18.52	116.09	122.20	-6.11	Peak	

Orthogonal Axis:	X
Test Mode:	UNII-3/TX A Mode 5745MHz

Vertical

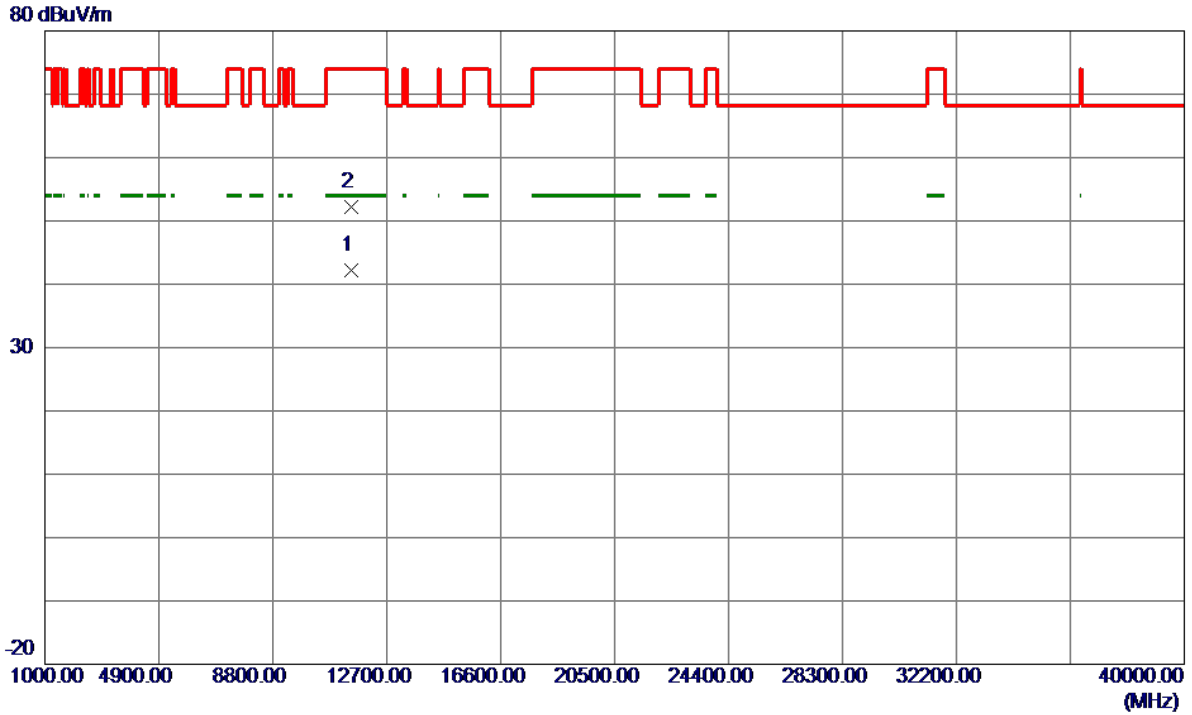

No.	Freq. MHz	Reading Level dBuV/m	Correct Factor dB	Measure ment dBuV/m	Limit dBuV/m	Margin dB	Detector	Comment
1 *	11491.7500	26.21	15.95	42.16	54.00	-11.84	AVG	
2	11493.4500	36.16	15.95	52.11	74.00	-21.89	Peak	

Orthogonal Axis:	X
Test Mode:	UNII-3/TX A Mode 5745MHz

Horizontal

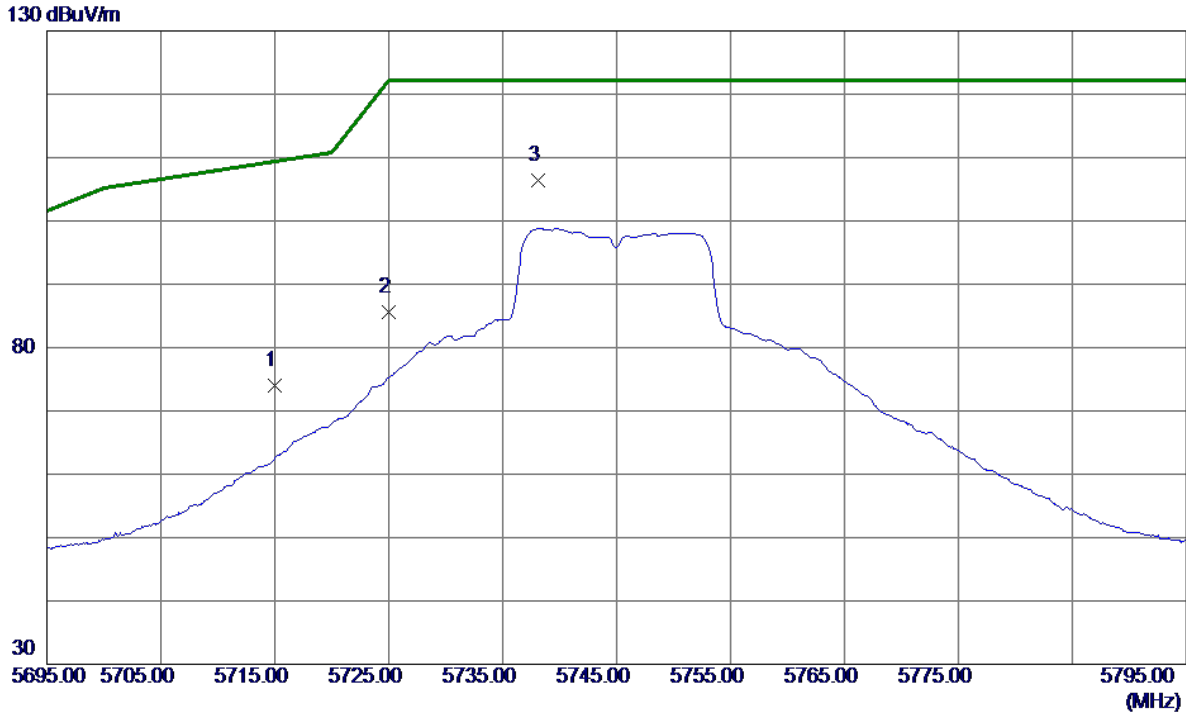

No.	Freq. MHz	Reading Level dBuV/m	Correct Factor dB	Measure ment dBuV/m	Limit dBuV/m	Margin dB	Detector	Comment
1	5715.0000	55.61	18.40	74.01	109.40	-35.39	Peak	
2	5725.0000	67.13	18.44	85.57	122.20	-36.63	Peak	
3 *	5738.1000	87.84	18.48	106.32	122.20	-15.88	Peak	

Orthogonal Axis:	X
Test Mode:	UNII-3/TX A Mode 5745MHz

Horizontal

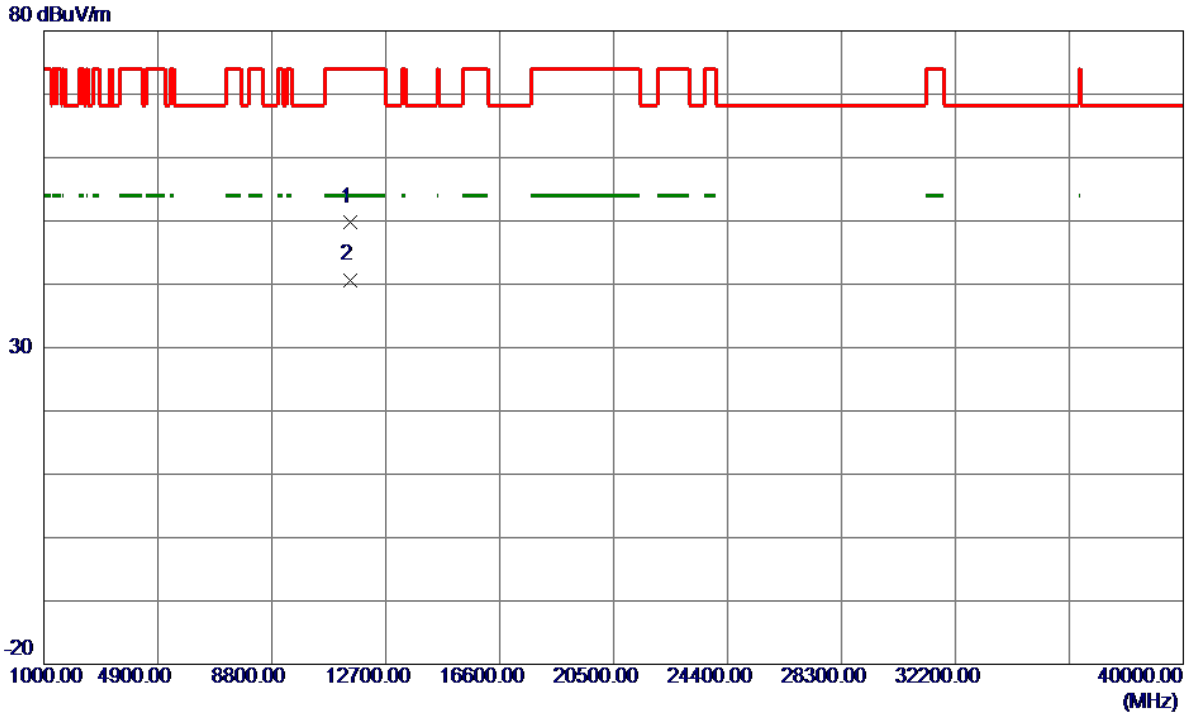

No.	Freq. MHz	Reading Level dBuV/m	Correct Factor dB	Measure ment dBuV/m	Limit dBuV/m	Margin dB	Detector	Comment
1	11491.6500	33.93	15.95	49.88	74.00	-24.12	Peak	
2 *	11491.8000	24.75	15.95	40.70	54.00	-13.30	AVG	

Orthogonal Axis:	X
Test Mode:	UNII-3/TX A Mode 5785MHz

Vertical

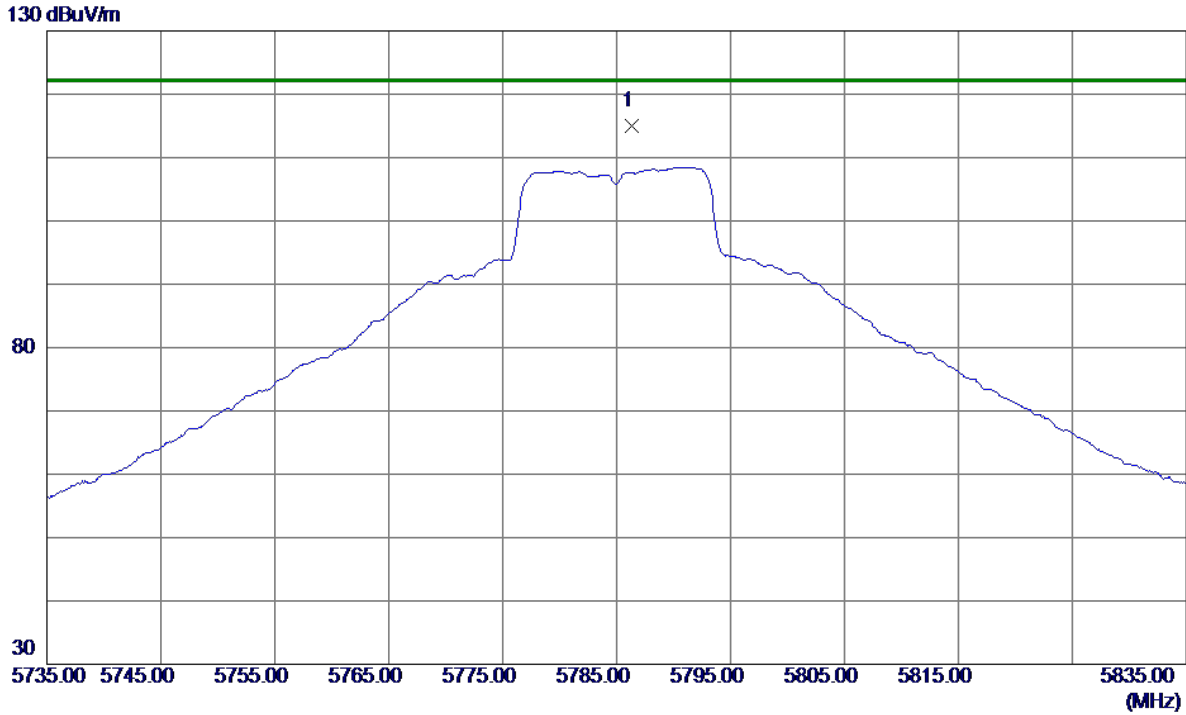

No.	Freq. MHz	Reading Level dBuV/m	Correct Factor dB	Measure ment dBuV/m	Limit dBuV/m	Margin dB	Detector	Comment
1 *	5786.3000	96.45	18.65	115.10	122.20	-7.10	Peak	

Orthogonal Axis:	X
Test Mode:	UNII-3/TX A Mode 5785MHz

Vertical

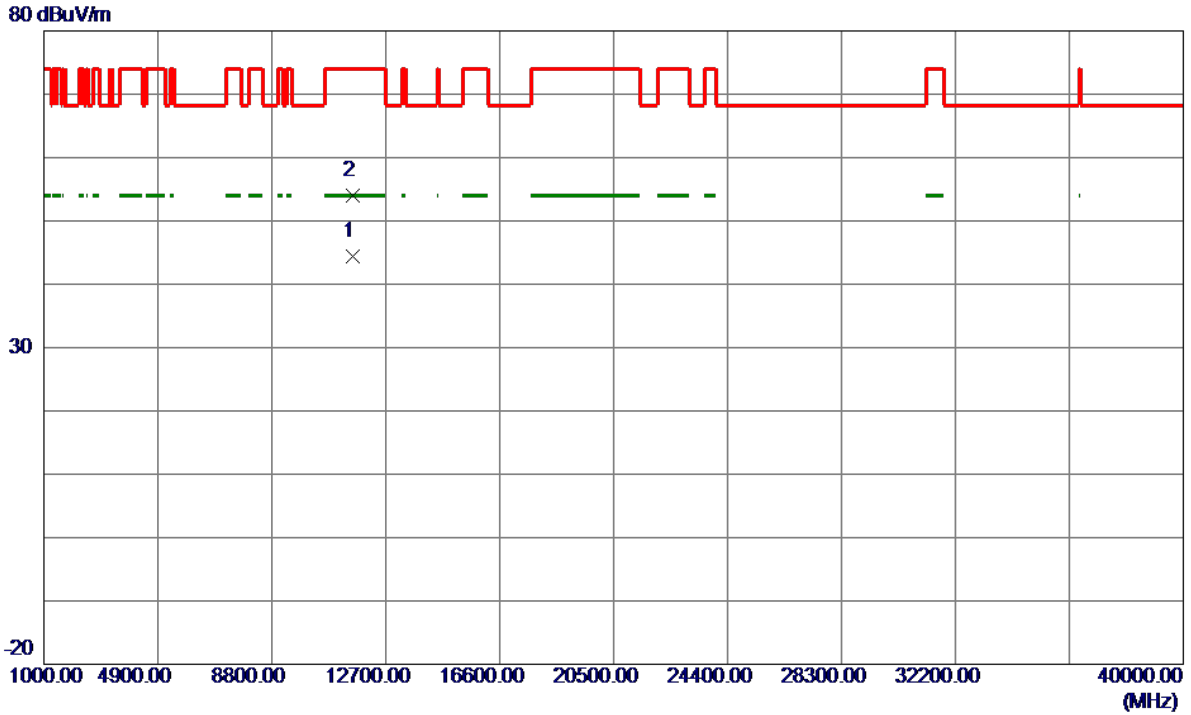

No.	Freq. MHz	Reading Level dBuV/m	Correct Factor dB	Measure ment dBuV/m	Limit dBuV/m	Margin dB	Detector	Comment
1 *	11569.8000	28.49	15.99	44.48	54.00	-9.52	AVG	
2	11572.3500	38.01	15.99	54.00	74.00	-20.00	Peak	

Orthogonal Axis:	X
Test Mode:	UNII-3/TX A Mode 5785MHz

Horizontal

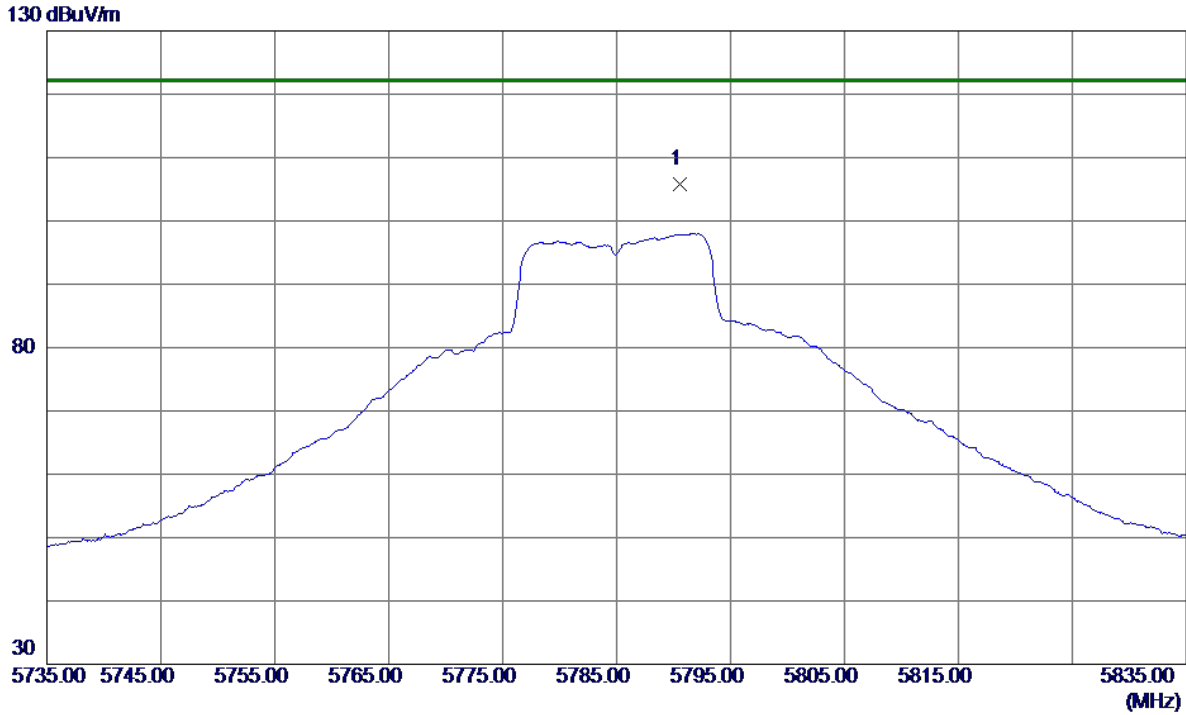

No.	Freq. MHz	Reading Level dBuV/m	Correct Factor dB	Measure ment dBuV/m	Limit dBuV/m	Margin dB	Detector	Comment
1 *	5790.6000	87.13	18.67	105.80	122.20	-16.40	Peak	

Orthogonal Axis:	X
Test Mode:	UNII-3/TX A Mode 5785MHz

Horizontal

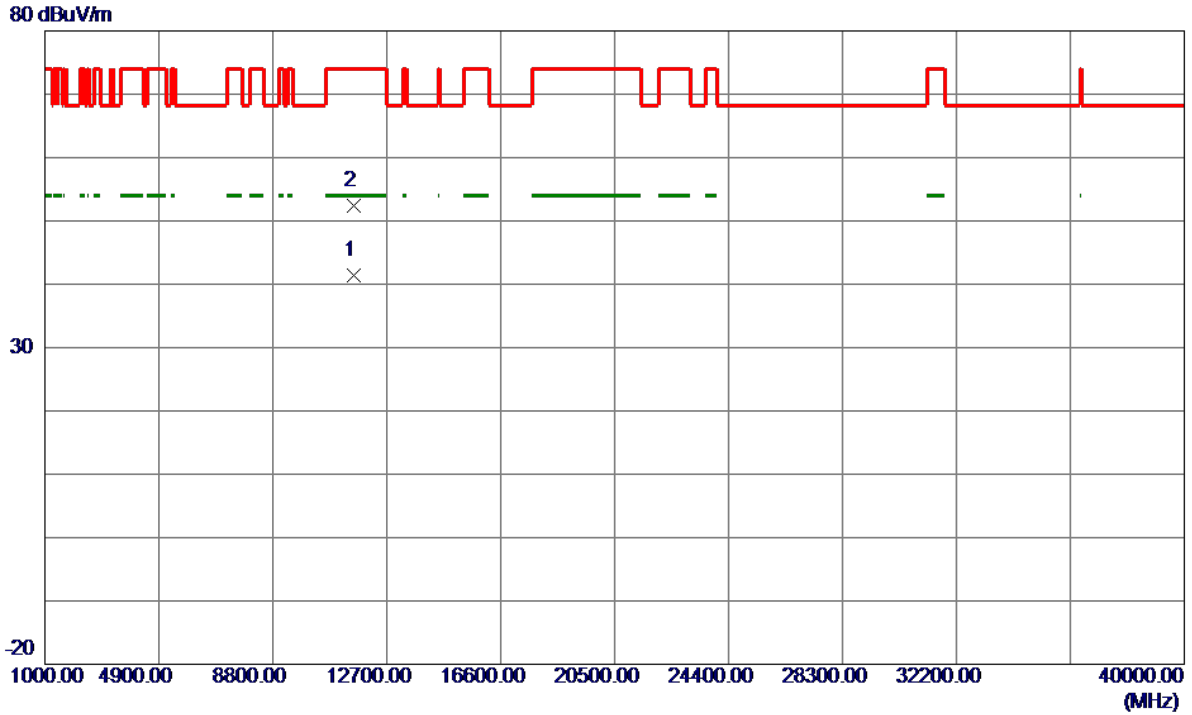

No.	Freq. MHz	Reading Level dBuV/m	Correct Factor dB	Measure ment dBuV/m	Limit dBuV/m	Margin dB	Detector	Comment
1 *	11569.8000	25.45	15.99	41.44	54.00	-12.56	AVG	
2	11571.0000	36.34	15.99	52.33	74.00	-21.67	Peak	

Orthogonal Axis:	X
Test Mode:	UNII-3/TX A Mode 5825MHz

Vertical

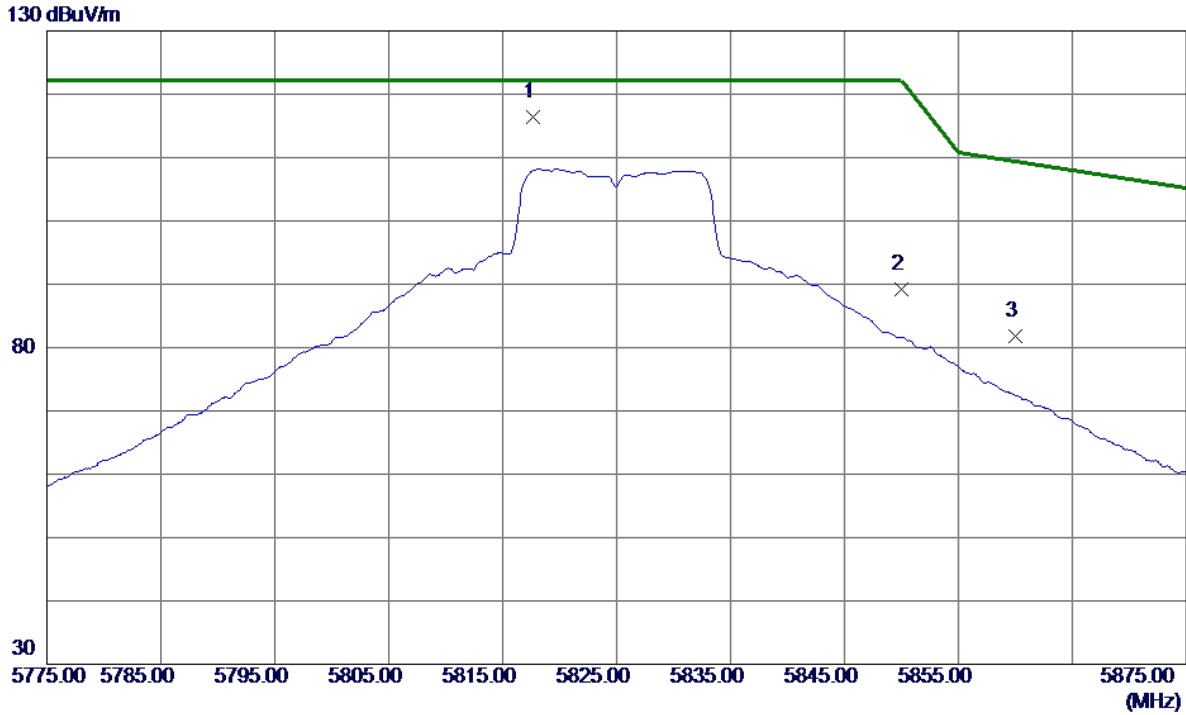

No.	Freq. MHz	Reading Level dBuV/m	Correct Factor dB	Measure ment dBuV/m	Limit dBuV/m	Margin dB	Detector	Comment
1 *	5817.7000	97.70	18.76	116.46	122.20	-5.74	Peak	
2	5850.0000	70.24	18.88	89.12	122.20	-33.08	Peak	
3	5860.0000	62.88	18.91	81.79	109.40	-27.61	Peak	

Orthogonal Axis:	X
Test Mode:	UNII-3/TX A Mode 5825MHz

Vertical

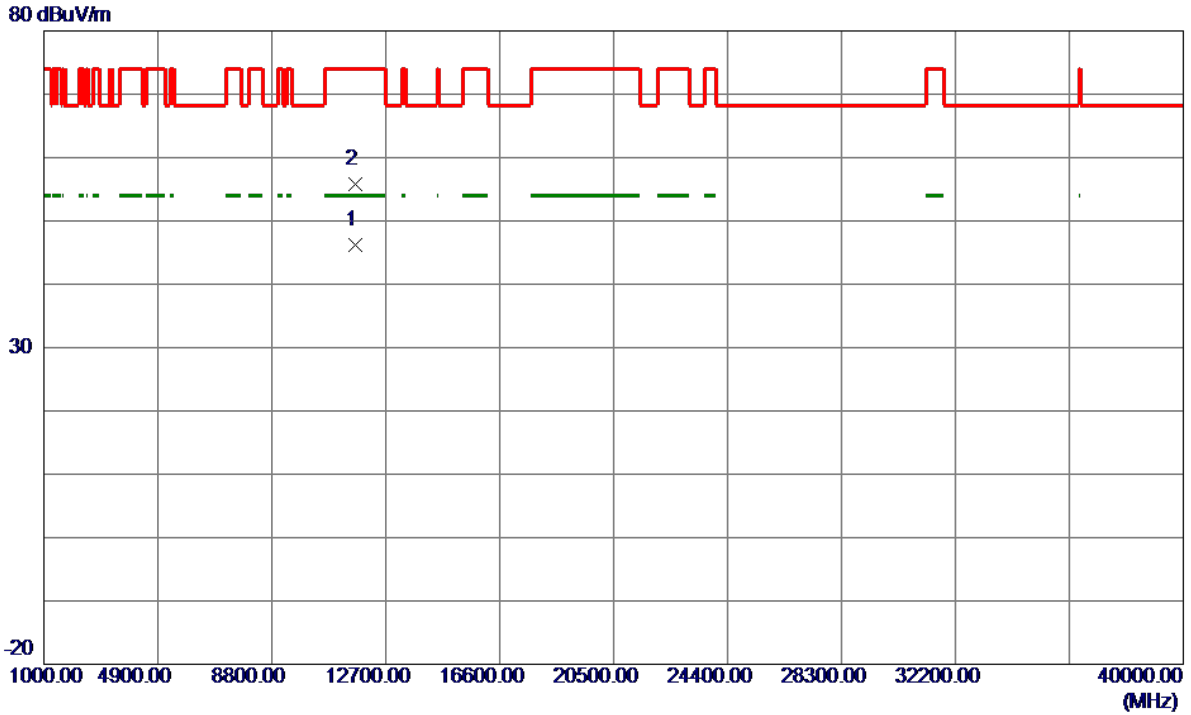

No.	Freq. MHz	Reading Level dBuV/m	Correct Factor dB	Measure ment dBuV/m	Limit dBuV/m	Margin dB	Detector	Comment
1 *	11649.8500	30.20	16.03	46.23	54.00	-7.77	AVG	
2	11651.9500	39.73	16.04	55.77	74.00	-18.23	Peak	

Orthogonal Axis:	X
Test Mode:	UNII-3/TX A Mode 5825MHz

Horizontal

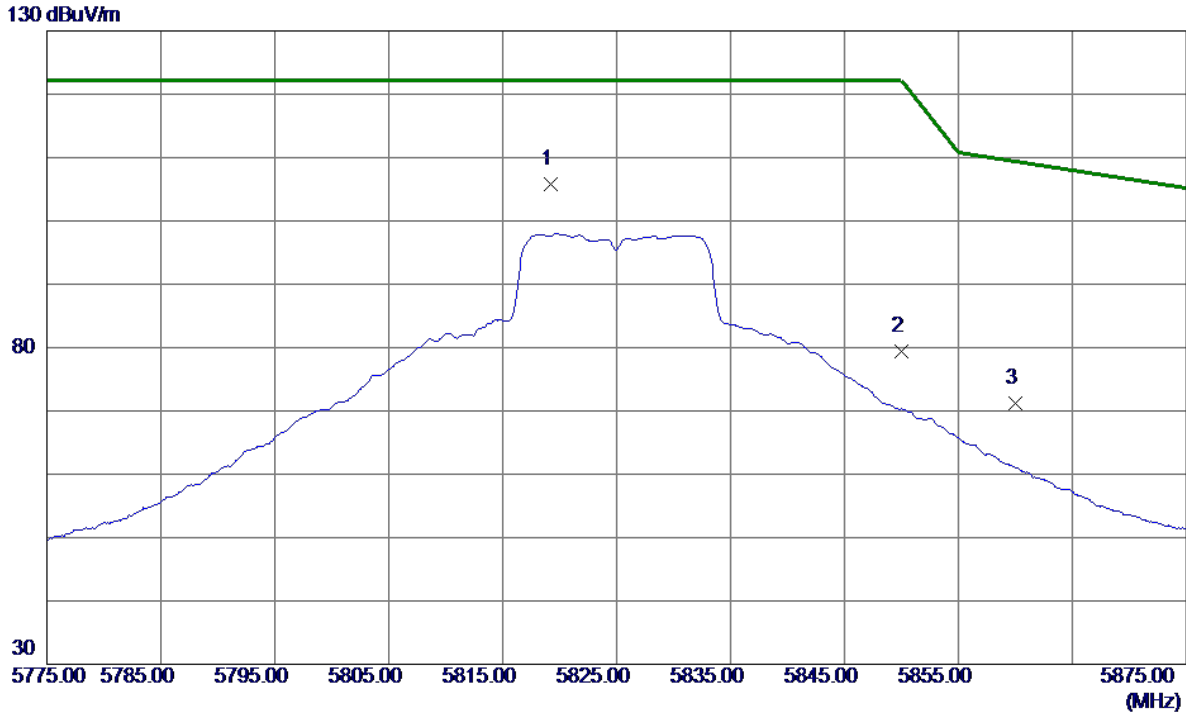

No.	Freq. MHz	Reading Level dBuV/m	Correct Factor dB	Measure ment dBuV/m	Limit dBuV/m	Margin dB	Detector	Comment
1 *	5819.2000	87.11	18.77	105.88	122.20	-16.32	Peak	
2	5850.0000	60.60	18.88	79.48	122.20	-42.72	Peak	
3	5860.0000	52.32	18.91	71.23	109.40	-38.17	Peak	

Orthogonal Axis:	X
Test Mode:	UNII-3/TX A Mode 5825MHz

Horizontal

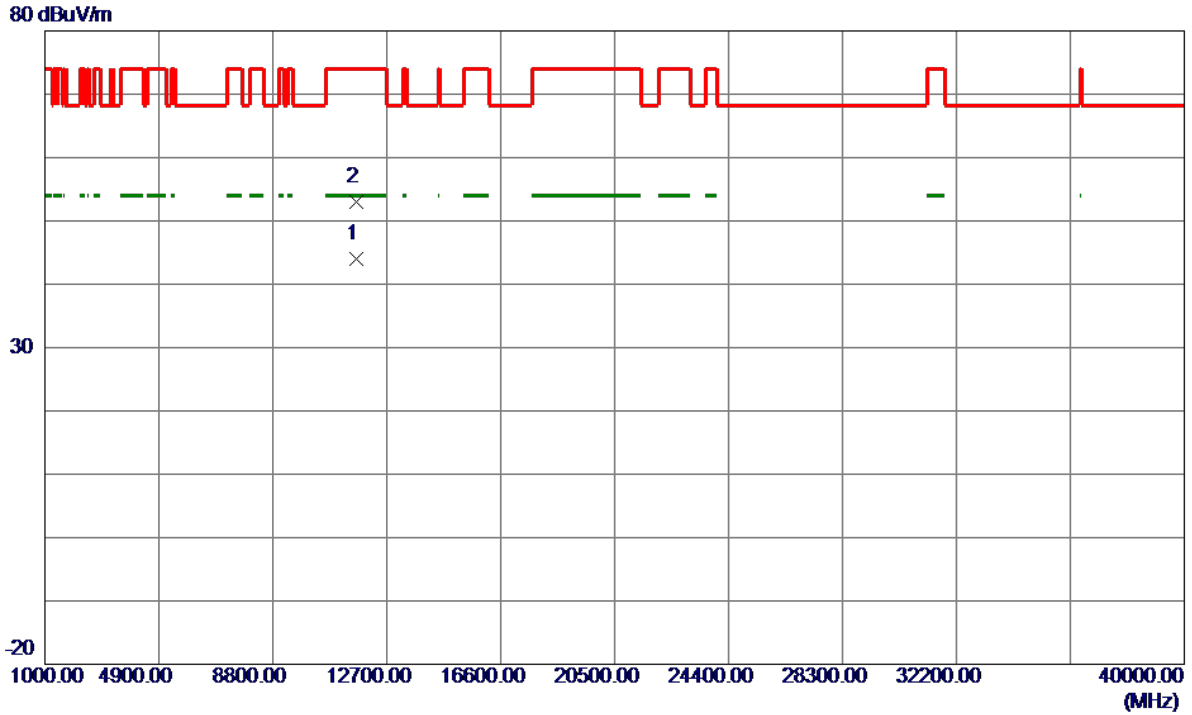

No.	Freq. MHz	Reading Level dBuV/m	Correct Factor dB	Measure ment dBuV/m	Limit dBuV/m	Margin dB	Detector	Comment
1 *	11649.9000	27.88	16.03	43.91	54.00	-10.09	AVG	
2	11659.3000	36.98	16.04	53.02	74.00	-20.98	Peak	

Orthogonal Axis:	X
Test Mode:	UNII-3/TX N20 Mode 5745MHz

Vertical

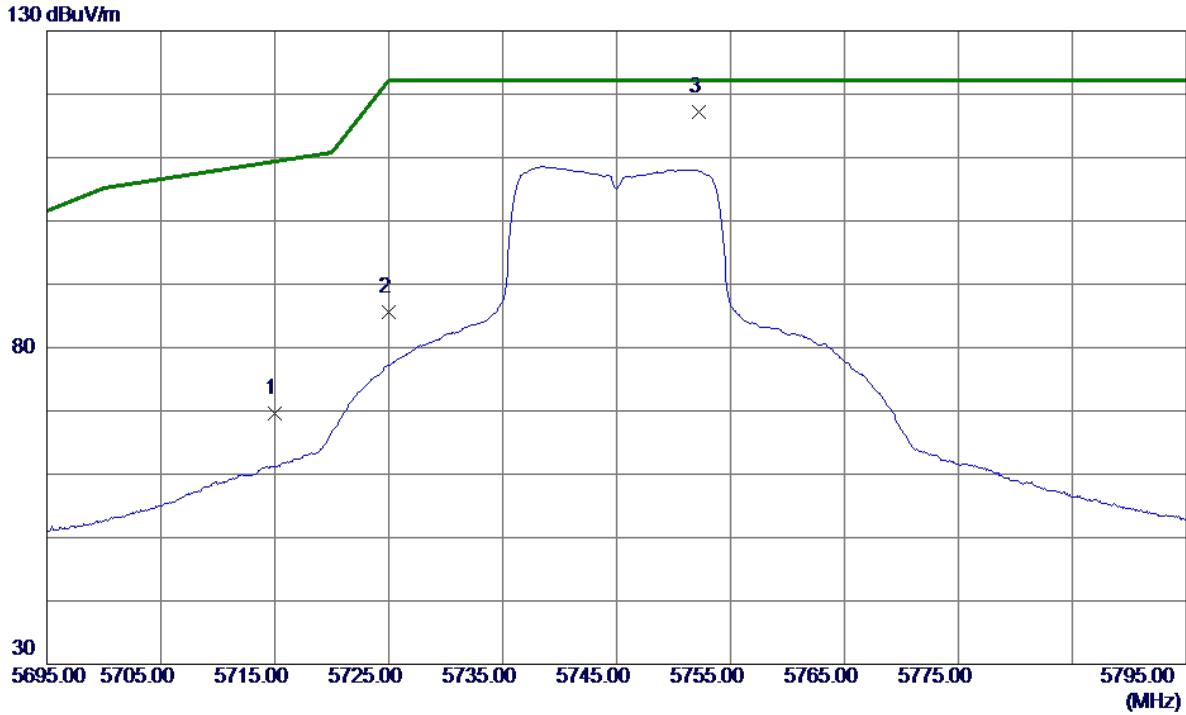

No.	Freq. MHz	Reading Level dBuV/m	Correct Factor dB	Measure ment dBuV/m	Limit dBuV/m	Margin dB	Detector	Comment
1	5715.0000	51.26	18.40	69.66	109.40	-39.74	Peak	
2	5725.0000	67.21	18.44	85.65	122.20	-36.55	Peak	
3 *	5752.2000	98.59	18.53	117.12	122.20	-5.08	Peak	

Orthogonal Axis:	X
Test Mode:	UNII-3/TX N20 Mode 5745MHz

Vertical

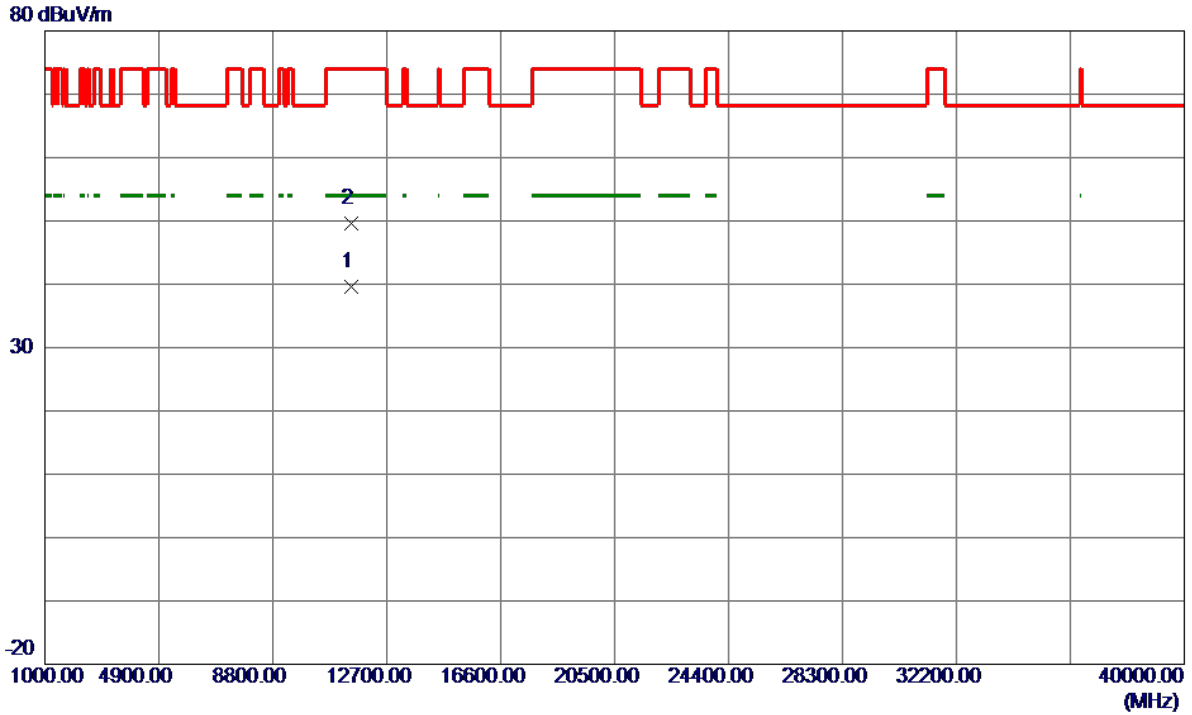

No.	Freq. MHz	Reading Level dBuV/m	Correct Factor dB	Measure ment dBuV/m	Limit dBuV/m	Margin dB	Detector	Comment
1 *	11487.2500	23.59	15.94	39.53	54.00	-14.47	AVG	
2	11494.6500	33.56	15.95	49.51	74.00	-24.49	Peak	

Orthogonal Axis:	X
Test Mode:	UNII-3/TX N20 Mode 5745MHz

Horizontal

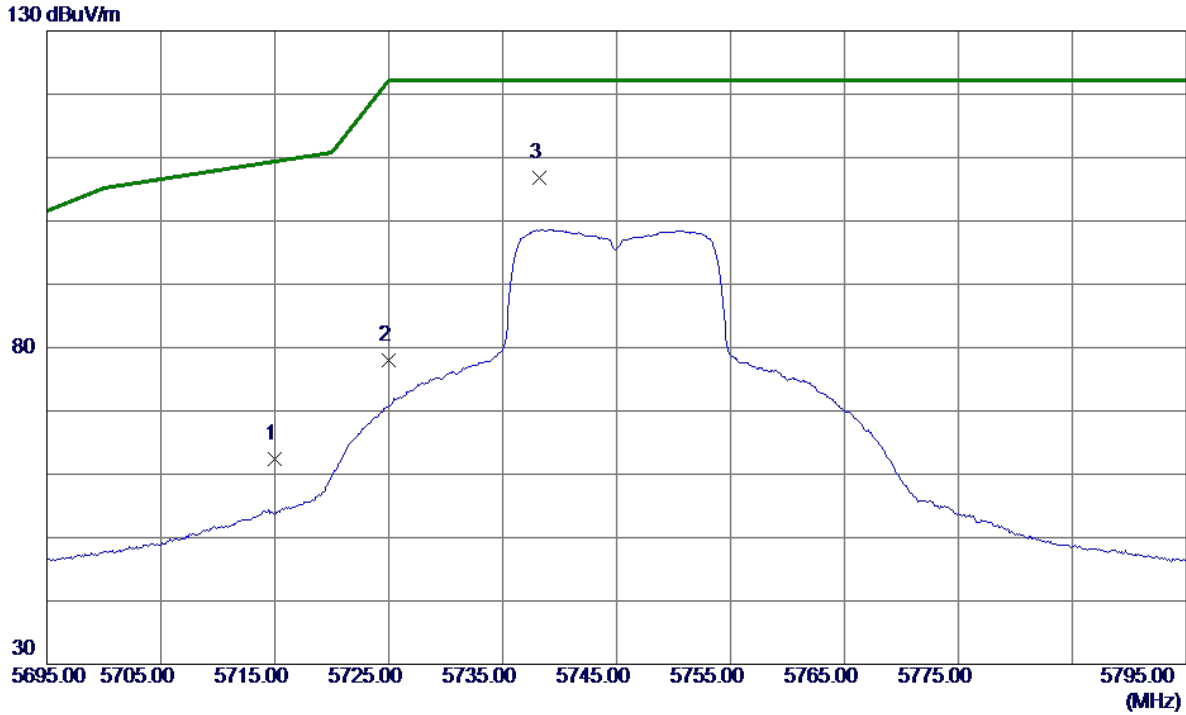

No.	Freq. MHz	Reading Level dBuV/m	Correct Factor dB	Measure ment dBuV/m	Limit dBuV/m	Margin dB	Detector	Comment
1	5715.0000	44.01	18.40	62.41	109.40	-46.99	Peak	
2	5725.0000	59.56	18.44	78.00	122.20	-44.20	Peak	
3 *	5738.2000	88.28	18.48	106.76	122.20	-15.44	Peak	

Orthogonal Axis:	X
Test Mode:	UNII-3/TX N20 Mode 5745MHz

Horizontal

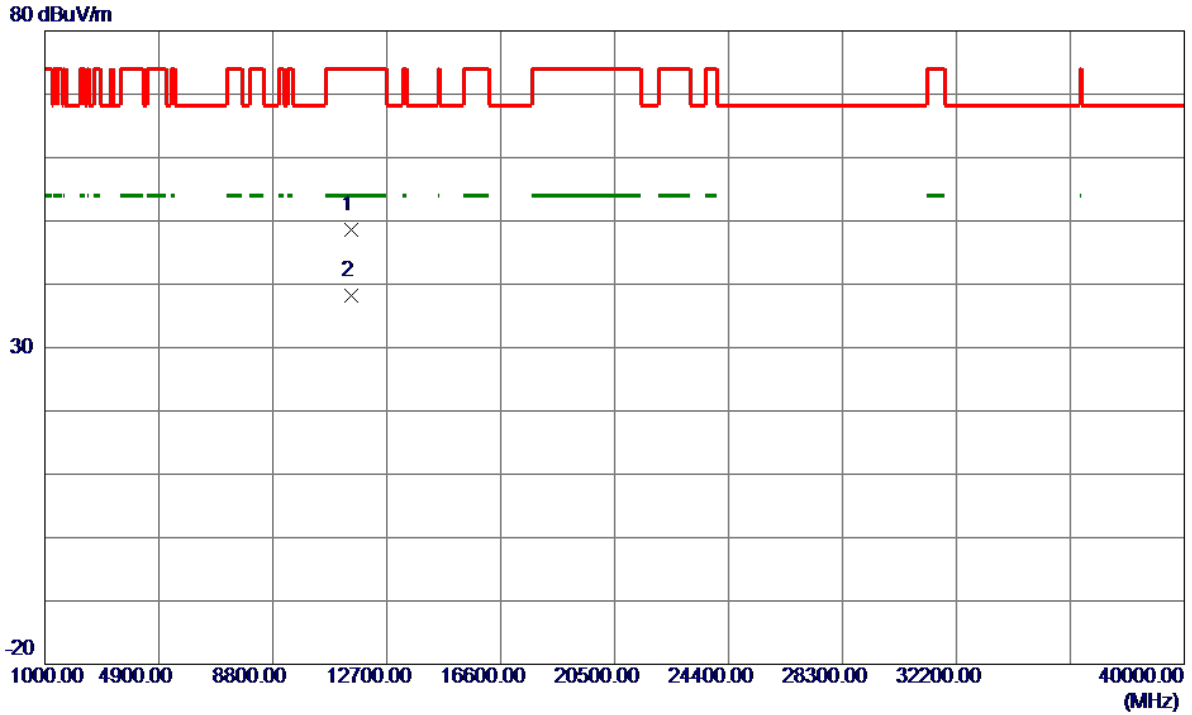

No.	Freq. MHz	Reading Level dBuV/m	Correct Factor dB	Measure ment dBuV/m	Limit dBuV/m	Margin dB	Detector	Comment
1	11492.4000	32.63	15.95	48.58	74.00	-25.42	Peak	
2 *	11495.3000	22.34	15.95	38.29	54.00	-15.71	AVG	

Orthogonal Axis:	X
Test Mode:	UNII-3/TX N20 Mode 5785MHz

Vertical

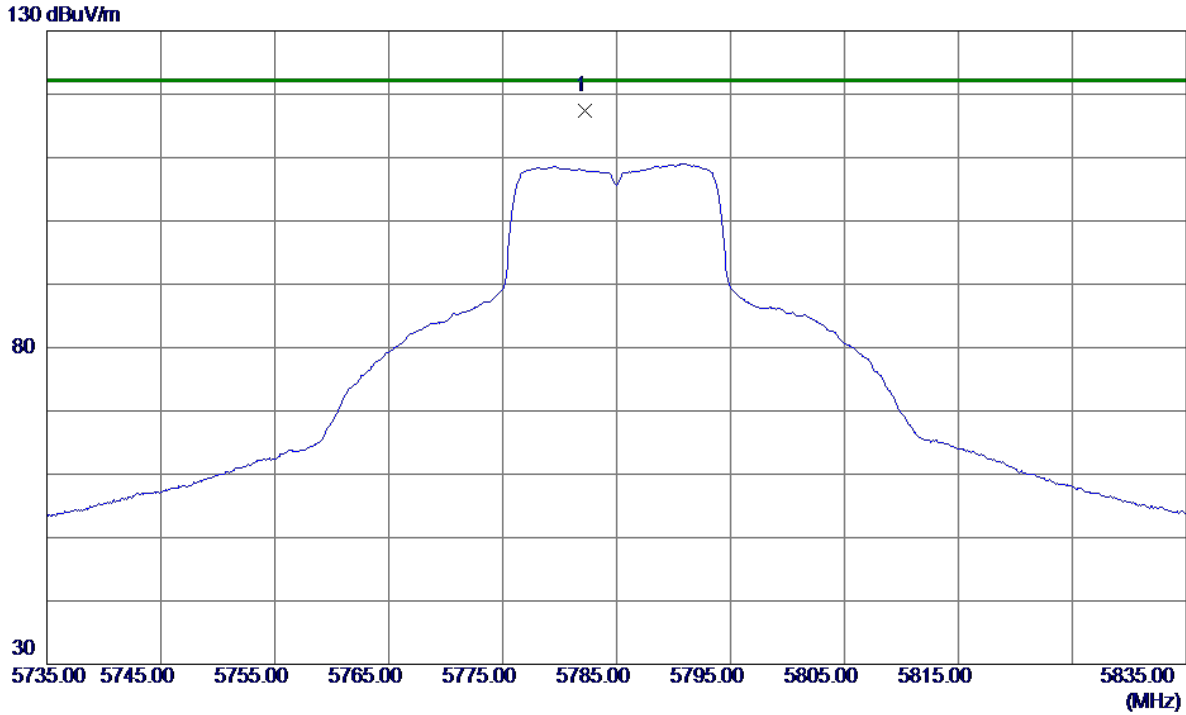

No.	Freq. MHz	Reading Level dBuV/m	Correct Factor dB	Measure ment dBuV/m	Limit dBuV/m	Margin dB	Detector	Comment
1 *	5782.2000	98.80	18.64	117.44	122.20	-4.76	Peak	

Orthogonal Axis:	X
Test Mode:	UNII-3/TX N20 Mode 5785MHz

Vertical

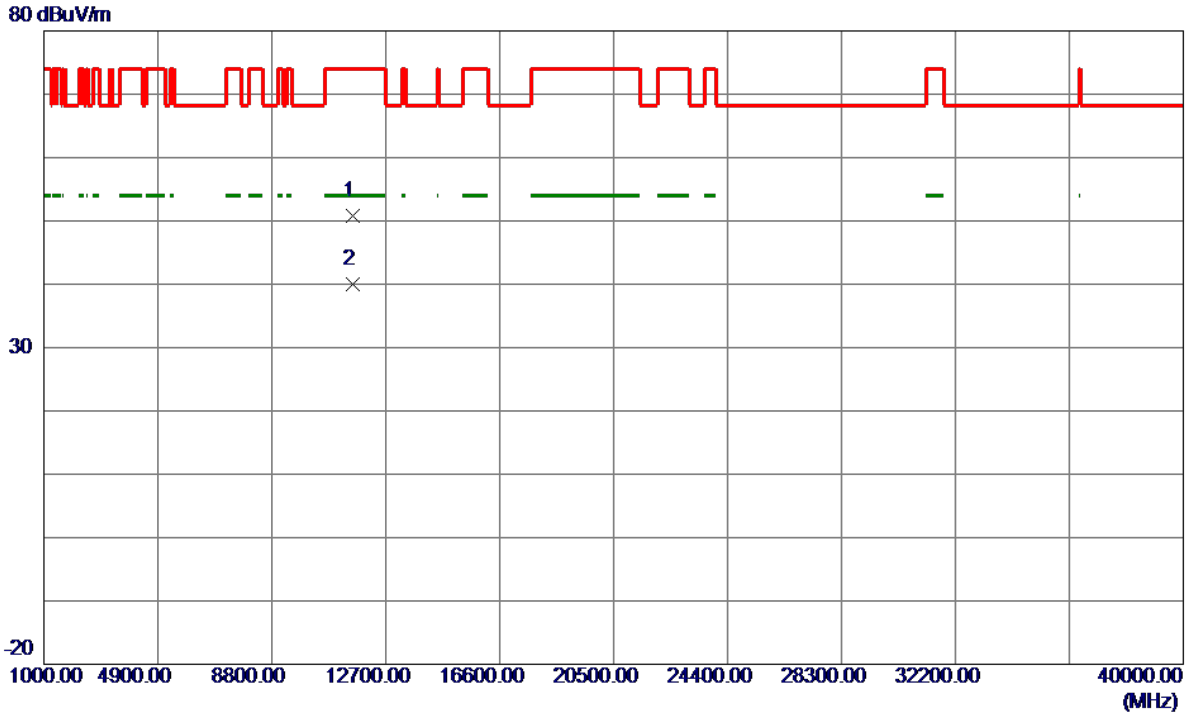

No.	Freq. MHz	Reading Level dBuV/m	Correct Factor dB	Measure ment dBuV/m	Limit dBuV/m	Margin dB	Detector	Comment
1	11570.9500	34.87	15.99	50.86	74.00	-23.14	Peak	
2 *	11574.4500	23.97	15.99	39.96	54.00	-14.04	AVG	

Orthogonal Axis:	X
Test Mode:	UNII-3/TX N20 Mode 5785MHz

Horizontal

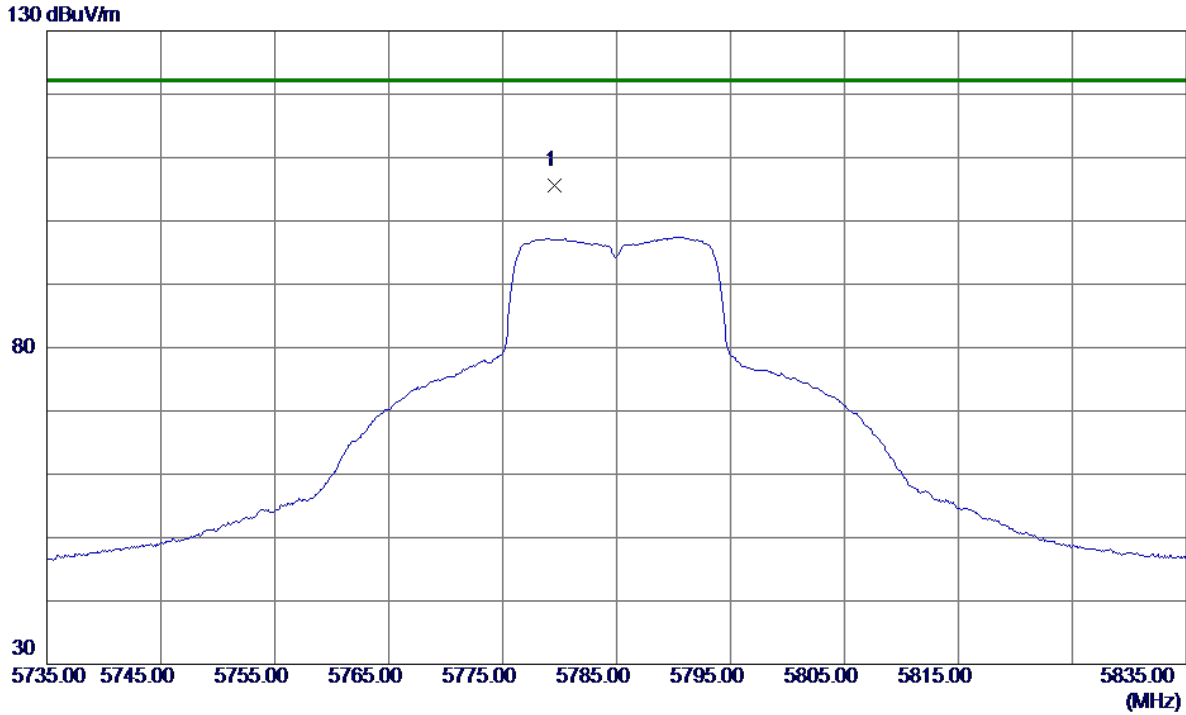

No.	Freq. MHz	Reading Level dBuV/m	Correct Factor dB	Measure ment dBuV/m	Limit dBuV/m	Margin dB	Detector	Comment
1 *	5779.6000	86.97	18.63	105.60	122.20	-16.60	Peak	

Orthogonal Axis:	X
Test Mode:	UNII-3/TX N20 Mode 5785MHz

Horizontal

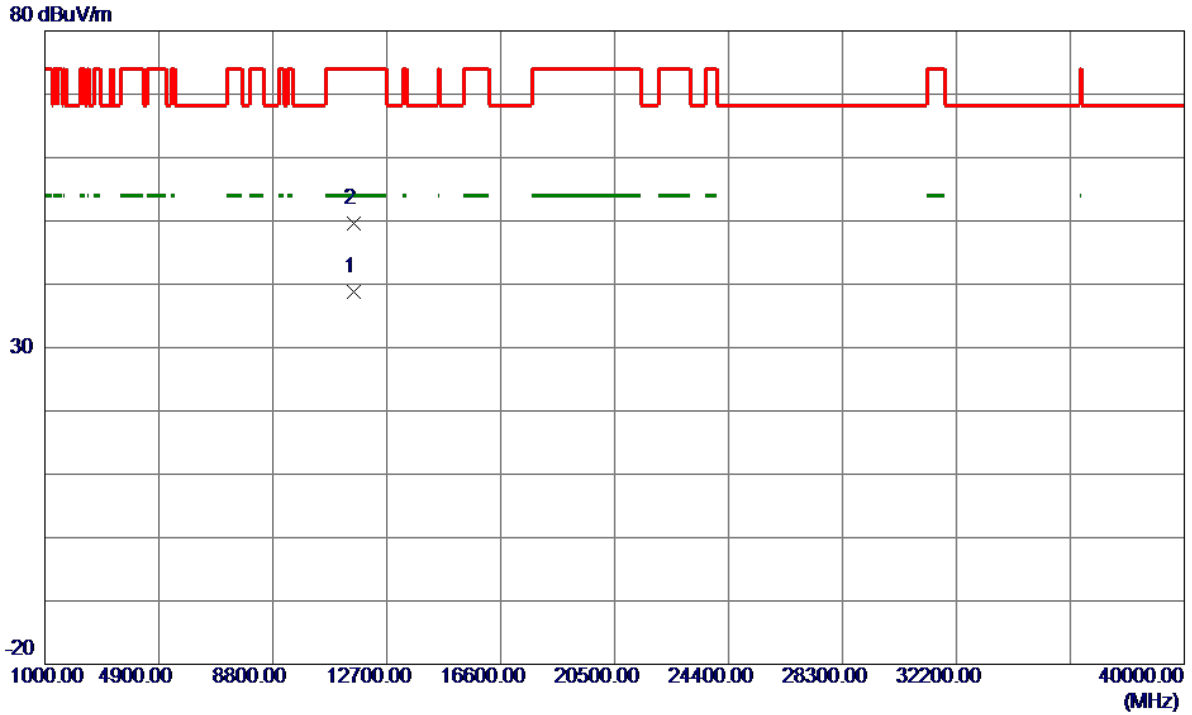

No.	Freq. MHz	Reading Level dBuV/m	Correct Factor dB	Measure ment dBuV/m	Limit dBuV/m	Margin dB	Detector	Comment
1 *	11568.5500	22.89	15.99	38.88	54.00	-15.12	AVG	
2	11576.6500	33.61	16.00	49.61	74.00	-24.39	Peak	

Orthogonal Axis:	X
Test Mode:	UNII-3/TX N20 Mode 5825MHz

Vertical

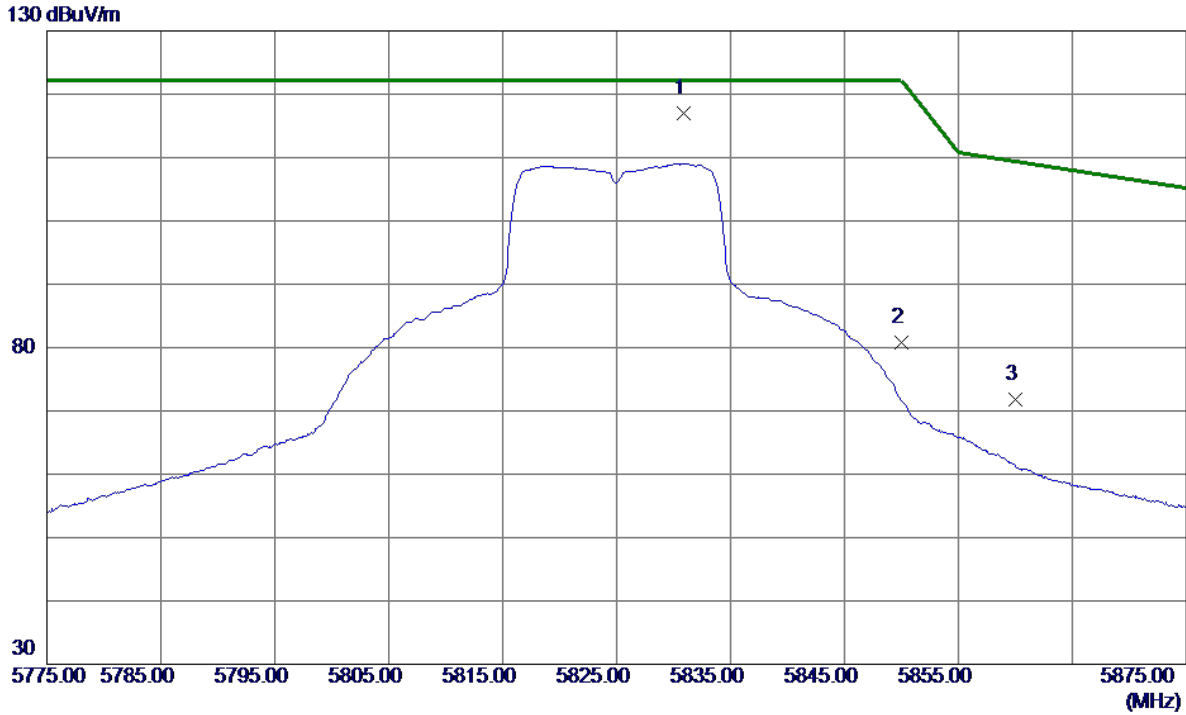

No.	Freq. MHz	Reading Level dBuV/m	Correct Factor dB	Measure ment dBuV/m	Limit dBuV/m	Margin dB	Detector	Comment
1 *	5830.9000	98.26	18.81	117.07	122.20	-5.13	Peak	
2	5850.0000	62.00	18.88	80.88	122.20	-41.32	Peak	
3	5860.0000	52.87	18.91	71.78	109.40	-37.62	Peak	

Orthogonal Axis:	X
Test Mode:	UNII-3/TX N20 Mode 5825MHz

Vertical

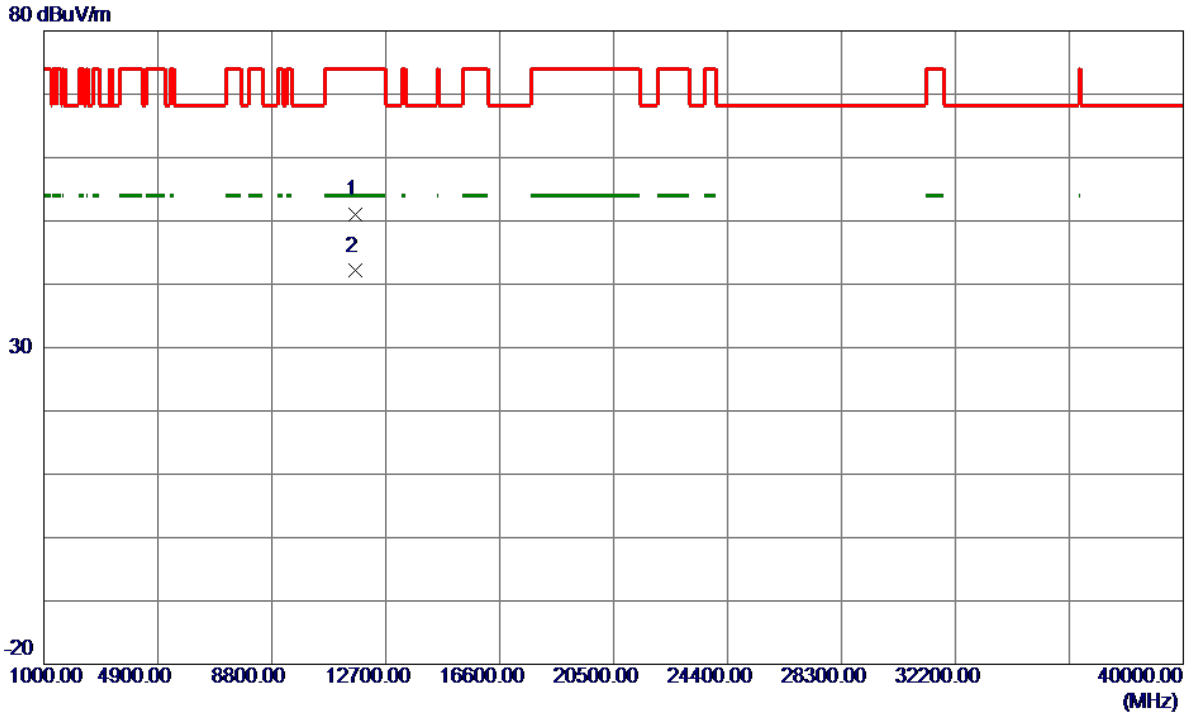

No.	Freq. MHz	Reading Level dBuV/m	Correct Factor dB	Measure ment dBuV/m	Limit dBuV/m	Margin dB	Detector	Comment
1	11648.6500	35.05	16.03	51.08	74.00	-22.92	Peak	
2 *	11649.5000	26.07	16.03	42.10	54.00	-11.90	AVG	

Orthogonal Axis:	X
Test Mode:	UNII-3/TX N20 Mode 5825MHz

Horizontal

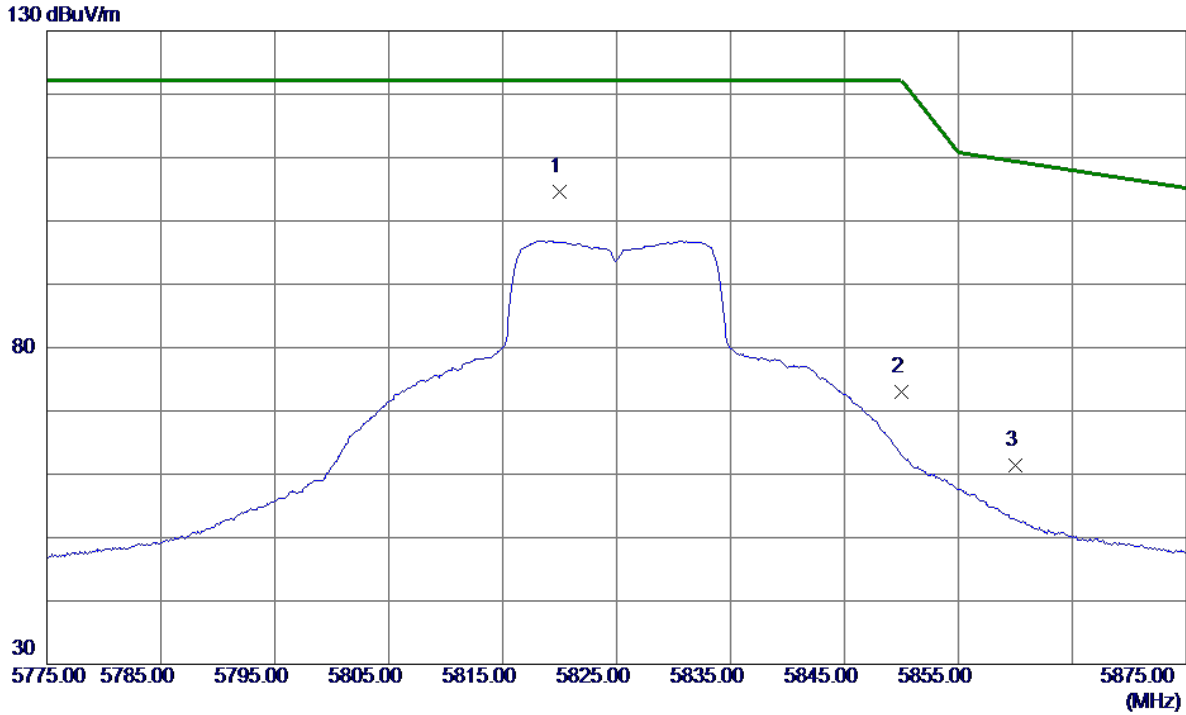

No.	Freq. MHz	Reading Level dBuV/m	Correct Factor dB	Measure ment dBuV/m	Limit dBuV/m	Margin dB	Detector	Comment
1 *	5820.0000	85.76	18.77	104.53	122.20	-17.67	Peak	
2	5850.0000	54.11	18.88	72.99	122.20	-49.21	Peak	
3	5860.0000	42.50	18.91	61.41	109.40	-47.99	Peak	

Orthogonal Axis:	X
Test Mode:	UNII-3/TX N20 Mode 5825MHz

Horizontal

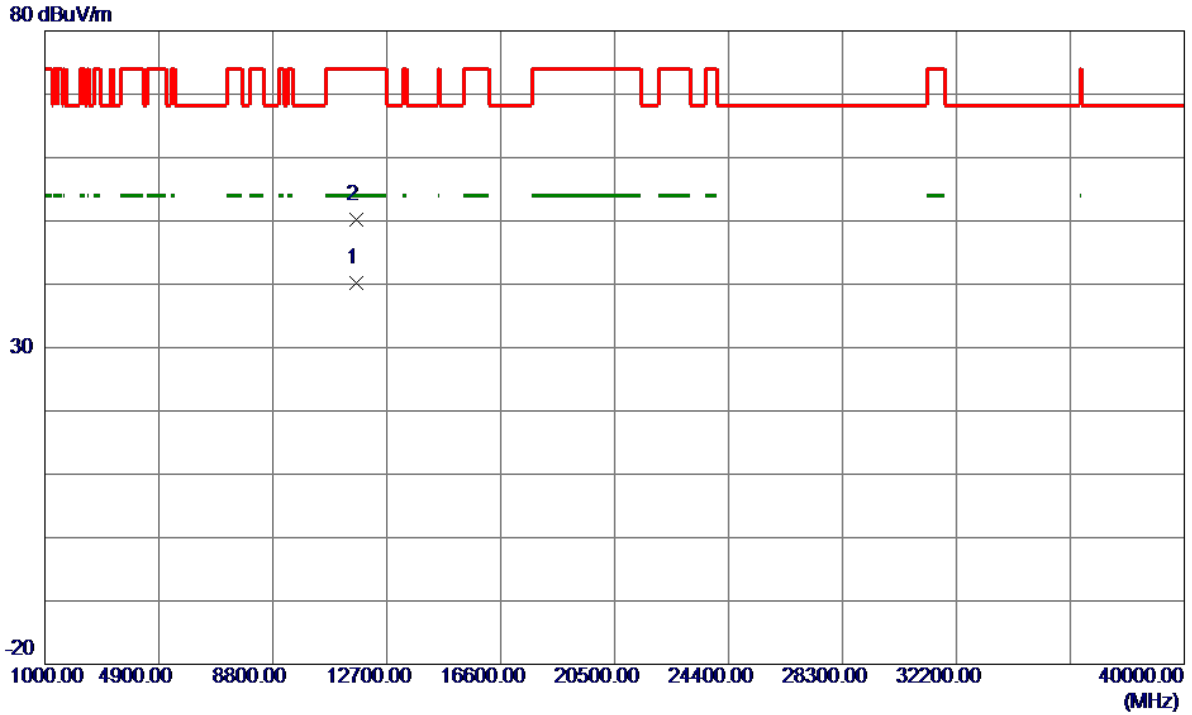

No.	Freq. MHz	Reading Level dBuV/m	Correct Factor dB	Measure ment dBuV/m	Limit dBuV/m	Margin dB	Detector	Comment
1 *	11650.1500	24.08	16.03	40.11	54.00	-13.89	AVG	
2	11652.6000	34.18	16.04	50.22	74.00	-23.78	Peak	

Orthogonal Axis:	X
Test Mode:	UNII-3/TX N40 Mode 5755MHz

Vertical

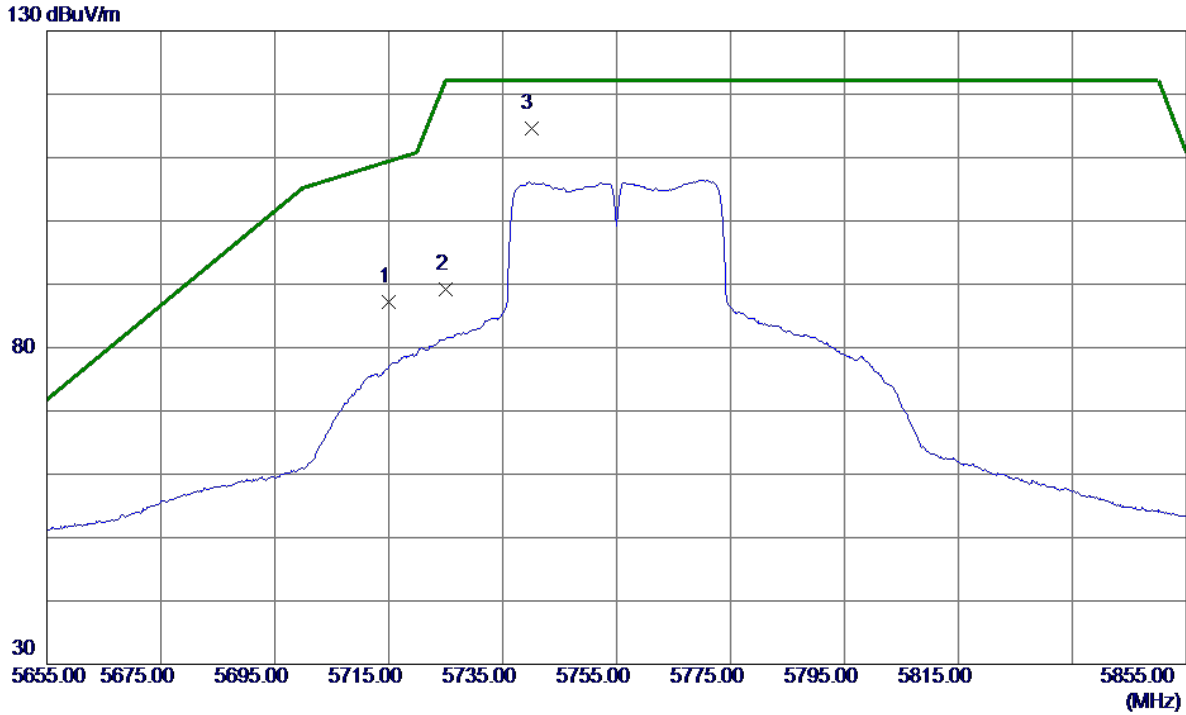

No.	Freq. MHz	Reading Level dBuV/m	Correct Factor dB	Measure ment dBuV/m	Limit dBuV/m	Margin dB	Detector	Comment
1	5715.0000	68.80	18.40	87.20	109.40	-22.20	Peak	
2	5725.0000	70.74	18.44	89.18	122.20	-33.02	Peak	
3 *	5740.0000	96.02	18.49	114.51	122.20	-7.69	Peak	

Orthogonal Axis:	X
Test Mode:	UNII-3/TX N40 Mode 5755MHz

Vertical

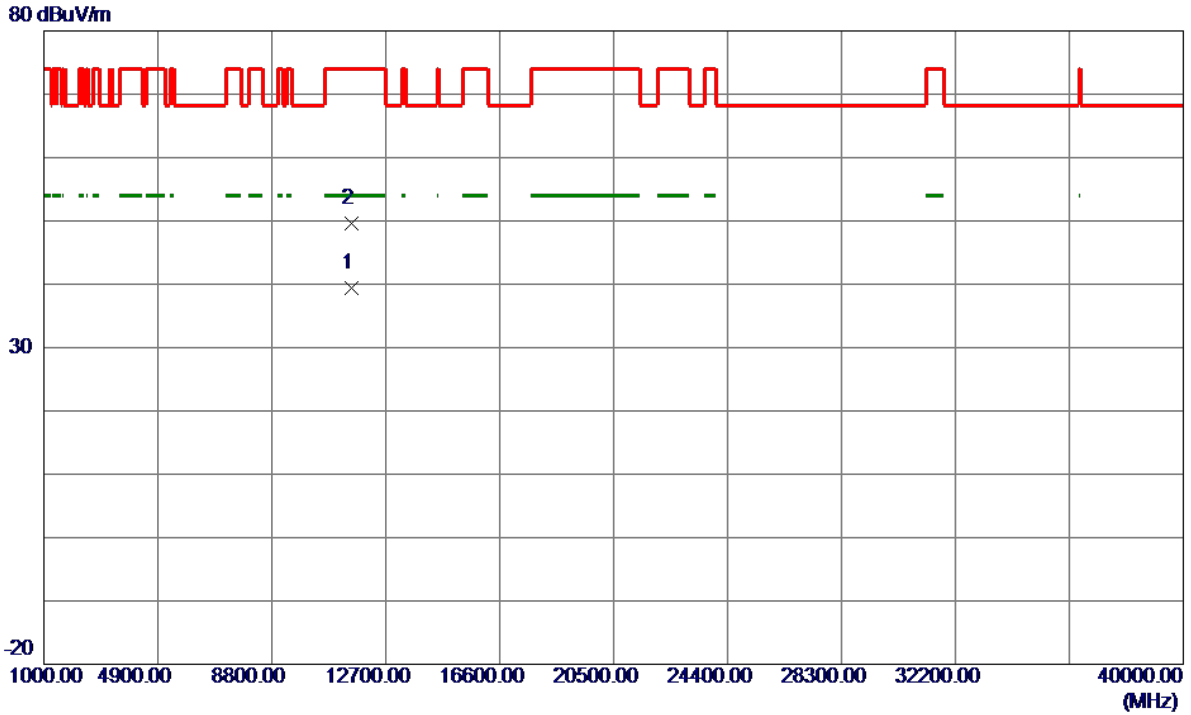

No.	Freq. MHz	Reading Level dBuV/m	Correct Factor dB	Measure ment dBuV/m	Limit dBuV/m	Margin dB	Detector	Comment
1 *	11520.3000	23.48	15.97	39.45	54.00	-14.55	AVG	
2	11527.1000	33.66	15.97	49.63	74.00	-24.37	Peak	

Orthogonal Axis:	X
Test Mode:	UNII-3/TX N40 Mode 5755MHz

Horizontal

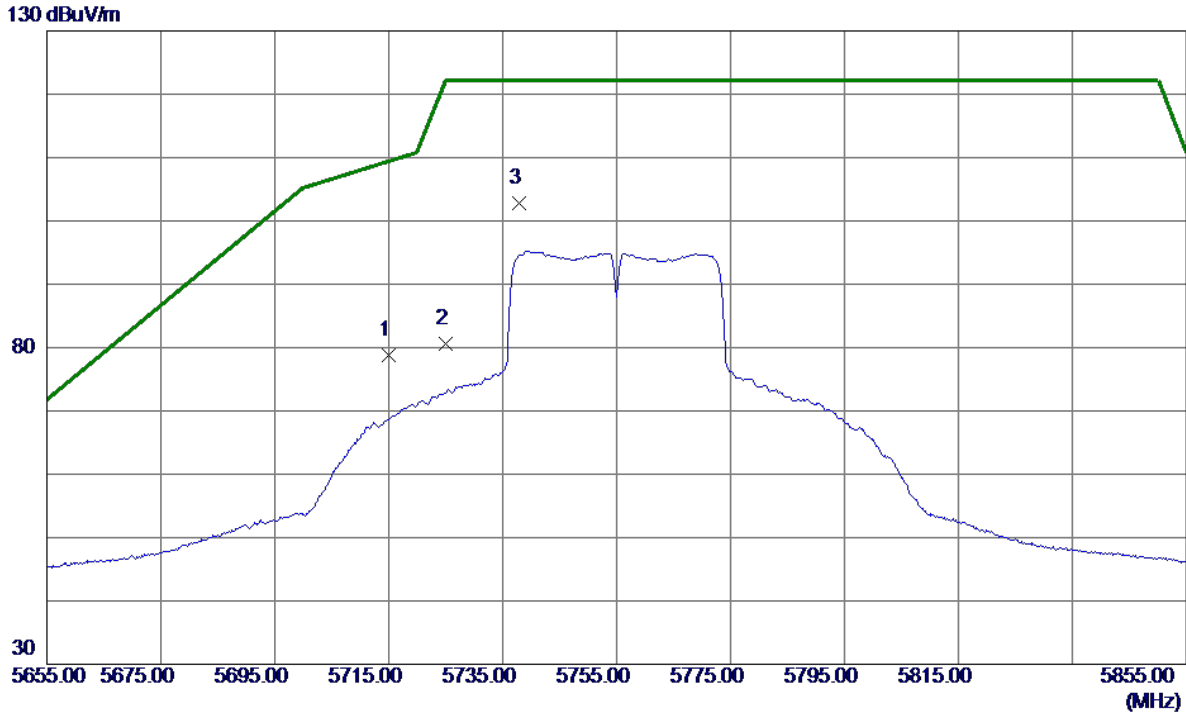

No.	Freq. MHz	Reading Level dBuV/m	Correct Factor dB	Measure ment dBuV/m	Limit dBuV/m	Margin dB	Detector	Comment
1	5715.0000	60.32	18.40	78.72	109.40	-30.68	Peak	
2	5725.0000	62.24	18.44	80.68	122.20	-41.52	Peak	
3 *	5737.8000	84.39	18.48	102.87	122.20	-19.33	Peak	

Orthogonal Axis:	X
Test Mode:	UNII-3/TX N40 Mode 5755MHz

Horizontal

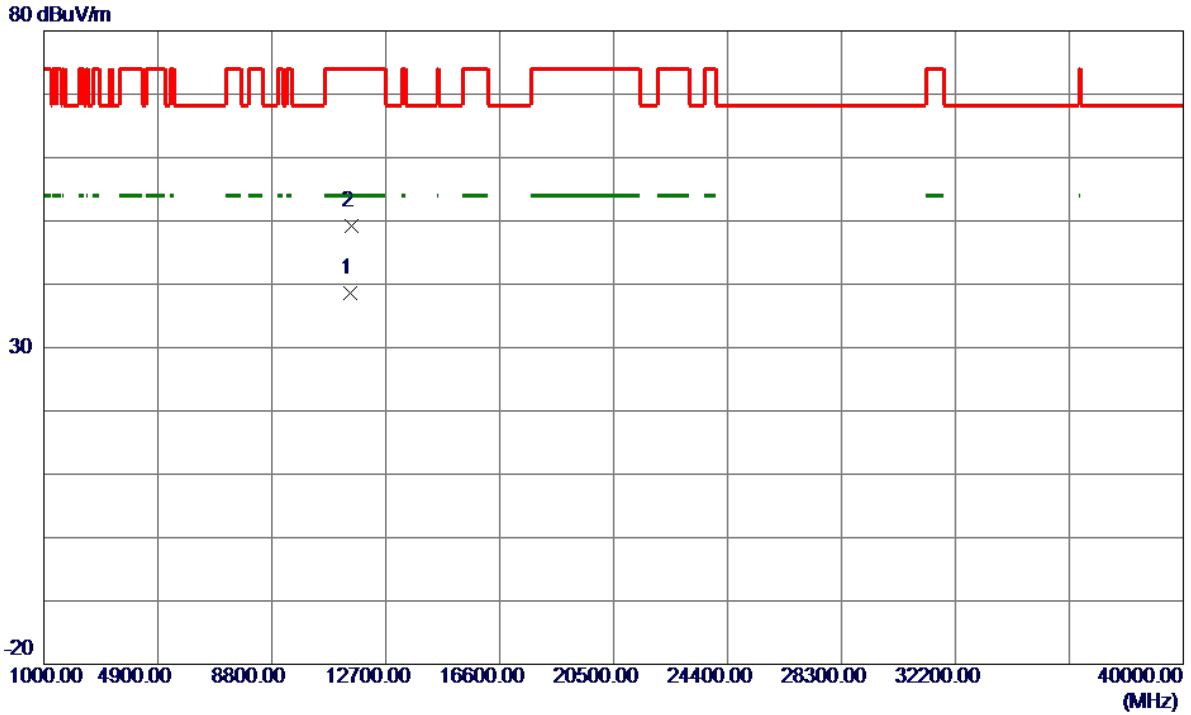

No.	Freq. MHz	Reading Level dBuV/m	Correct Factor dB	Measure ment dBuV/m	Limit dBuV/m	Margin dB	Detector	Comment
1 *	11507.1500	22.63	15.96	38.59	54.00	-15.41	AVG	
2	11524.1500	33.28	15.97	49.25	74.00	-24.75	Peak	

Orthogonal Axis:	X
Test Mode:	UNII-3/TX N40 Mode 5795MHz

Vertical

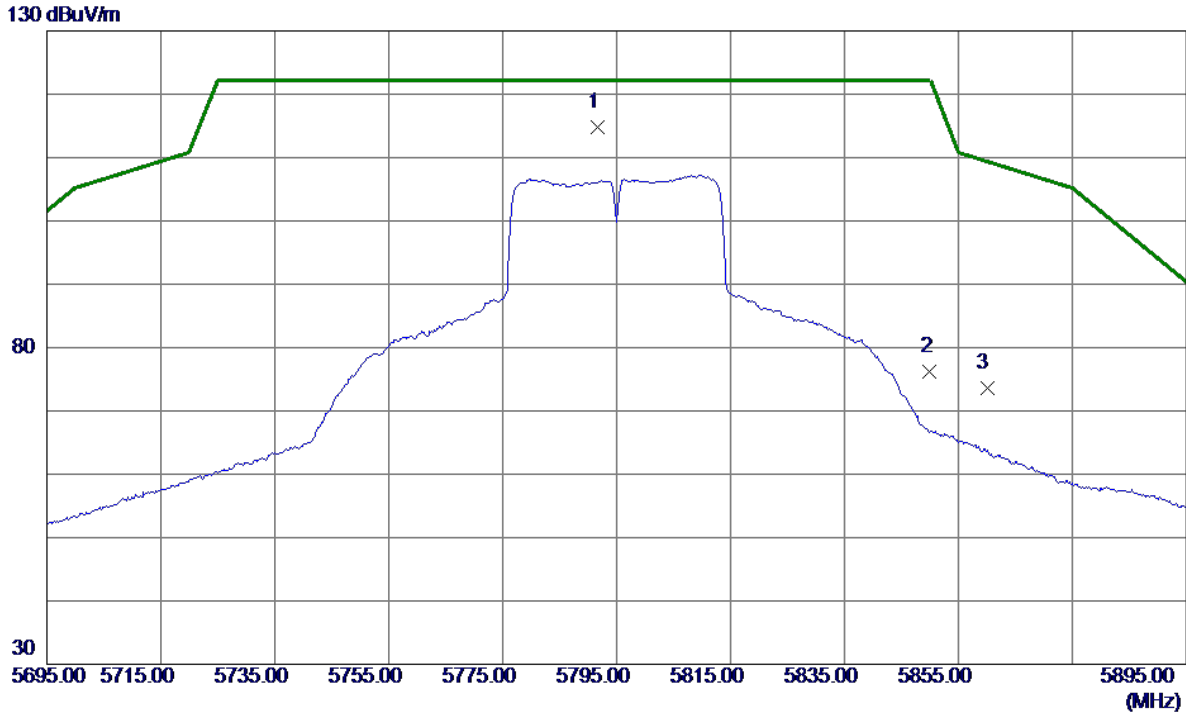

No.	Freq. MHz	Reading Level dBuV/m	Correct Factor dB	Measure ment dBuV/m	Limit dBuV/m	Margin dB	Detector	Comment
1 *	5791.6000	96.22	18.67	114.89	122.20	-7.31	Peak	
2	5850.0000	57.41	18.88	76.29	122.20	-45.91	Peak	
3	5860.0000	54.62	18.91	73.53	109.40	-35.87	Peak	

Orthogonal Axis:	X
Test Mode:	UNII-3/TX N40 Mode 5795MHz

Vertical

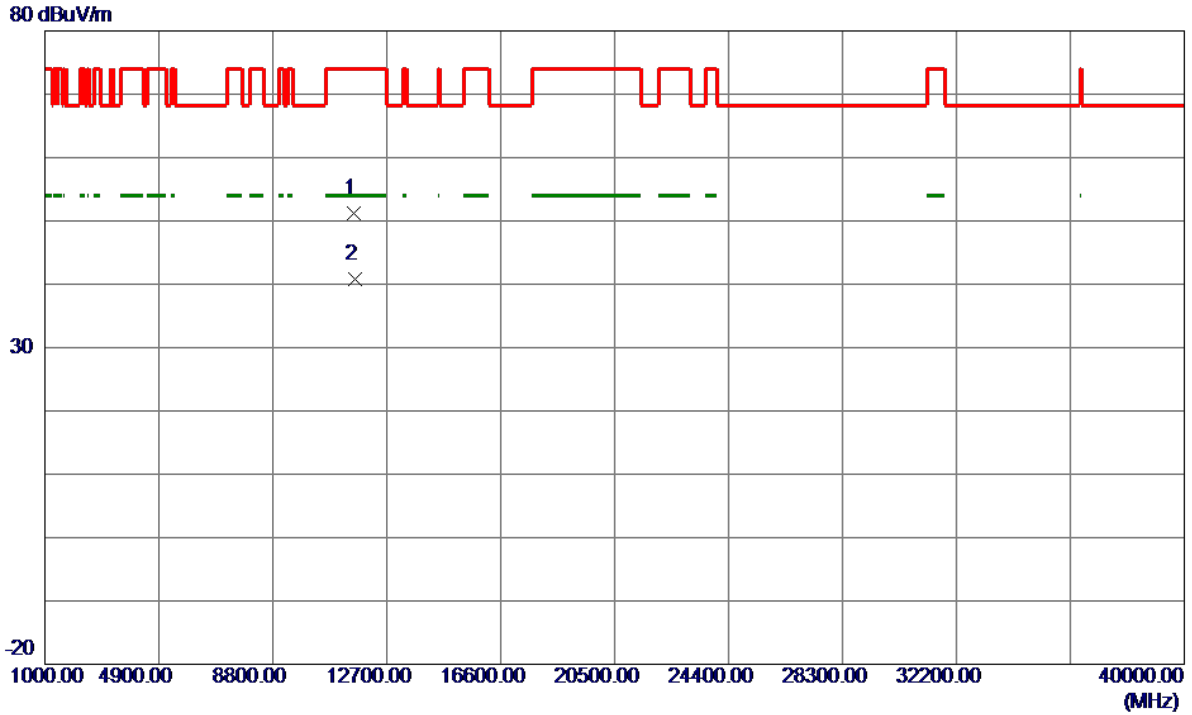

No.	Freq. MHz	Reading Level dBuV/m	Correct Factor dB	Measure ment dBuV/m	Limit dBuV/m	Margin dB	Detector	Comment
1	11593.1500	35.17	16.00	51.17	74.00	-22.83	Peak	
2 *	11597.2500	24.85	16.01	40.86	54.00	-13.14	AVG	

Orthogonal Axis:	X
Test Mode:	UNII-3/TX N40 Mode 5795MHz

Horizontal

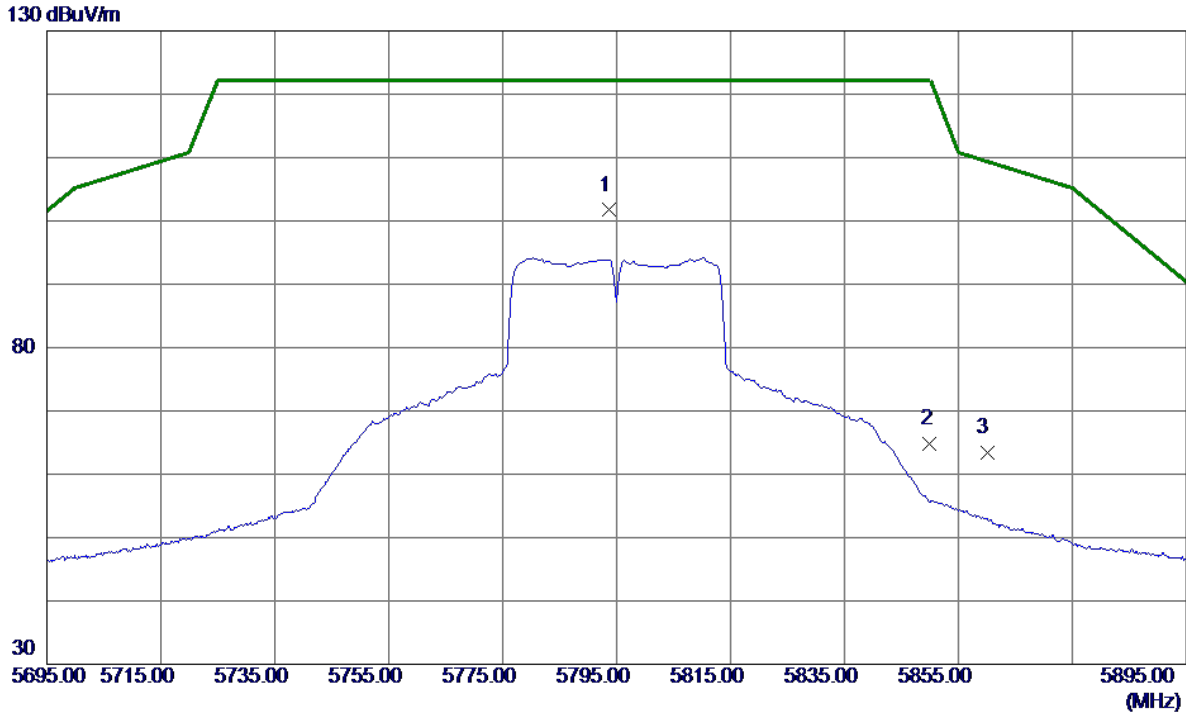

No.	Freq. MHz	Reading Level dBuV/m	Correct Factor dB	Measure ment dBuV/m	Limit dBuV/m	Margin dB	Detector	Comment
1 *	5793.6000	83.02	18.68	101.70	122.20	-20.50	Peak	
2	5850.0000	45.99	18.88	64.87	122.20	-57.33	Peak	
3	5860.0000	44.46	18.91	63.37	109.40	-46.03	Peak	

Orthogonal Axis:	X
Test Mode:	UNII-3/TX N40 Mode 5795MHz

Horizontal

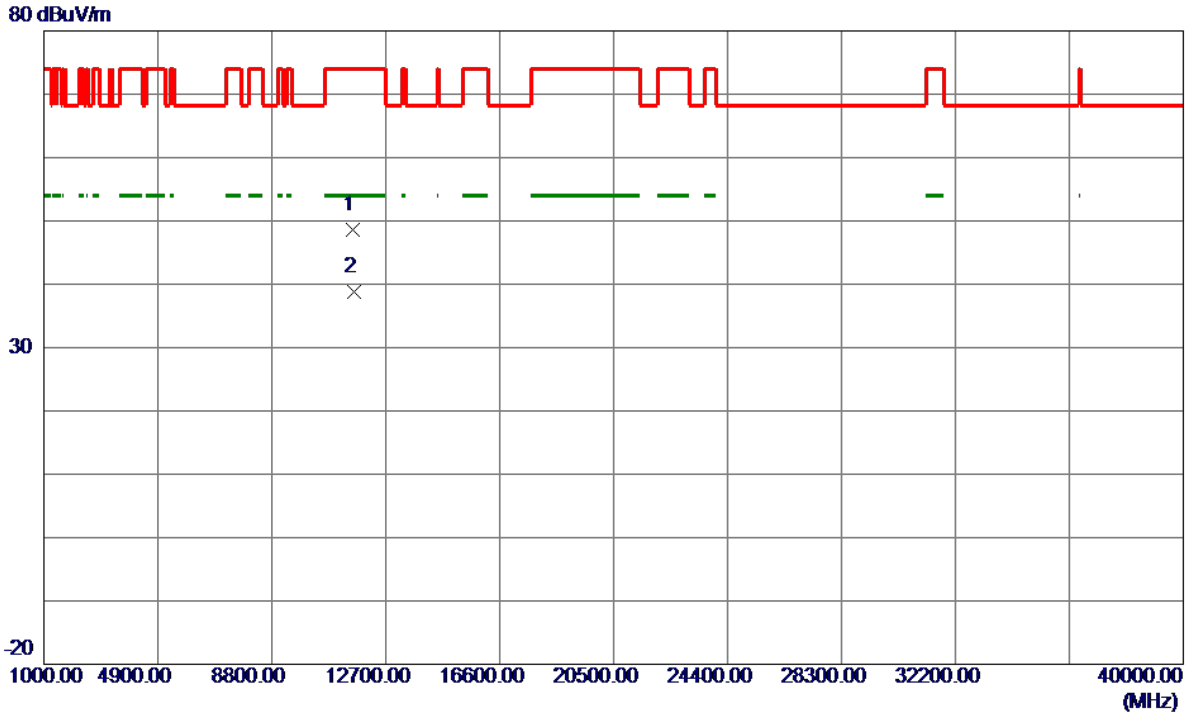

No.	Freq. MHz	Reading Level dBuV/m	Correct Factor dB	Measure ment dBuV/m	Limit dBuV/m	Margin dB	Detector	Comment
1	11577.2500	32.55	16.00	48.55	74.00	-25.45	Peak	
2 *	11596.9000	22.73	16.01	38.74	54.00	-15.26	AVG	

Orthogonal Axis:	X
Test Mode:	UNII-1/ TX AC20 Mode 5180MHz

Vertical

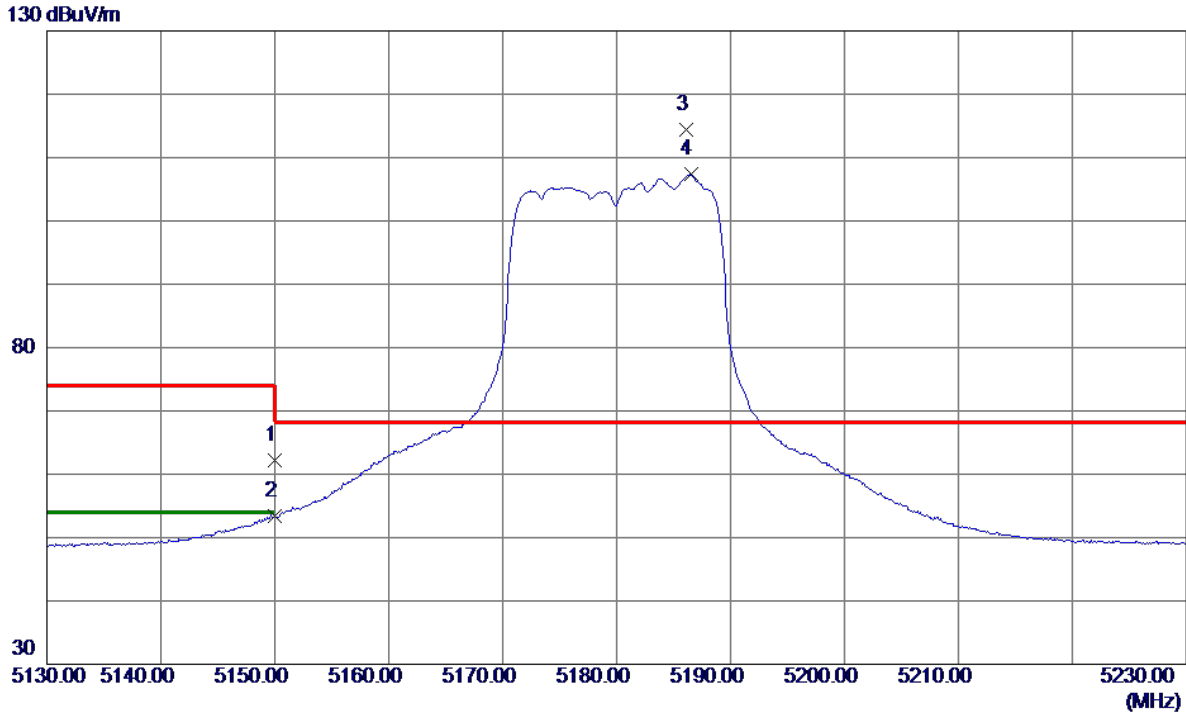

No.	Freq. MHz	Reading Level dBuV/m	Correct Factor dB	Measure ment dBuV/m	Limit dBuV/m	Margin dB	Detector	Comment
1	5150.0000	45.56	16.65	62.21	74.00	-11.79	Peak	
2	5150.0000	36.73	16.65	53.38	54.00	-0.62	AVG	
3 *	5186.1000	97.74	16.75	114.49	68.30	46.19	Peak	No Limit
4	5186.5000	90.65	16.75	107.40	999.00	-891.60	AVG	No Limit

Orthogonal Axis:	X
Test Mode:	UNII-1/ TX AC20 Mode 5180MHz

Vertical

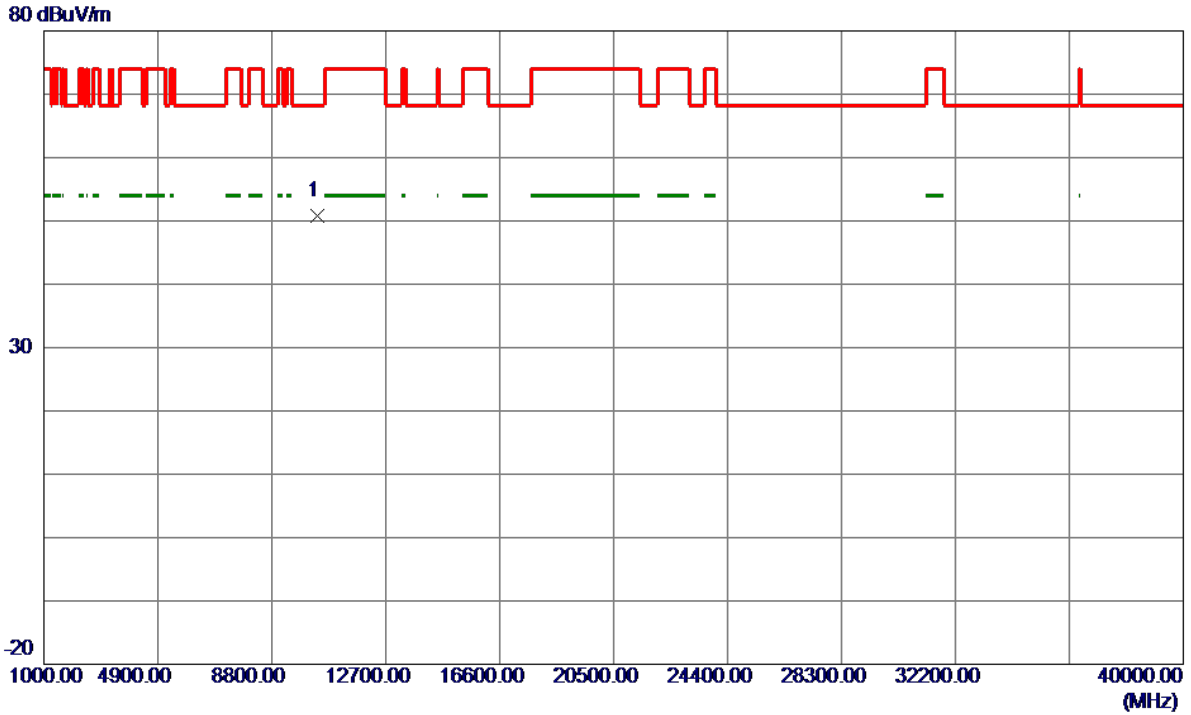

No.	Freq. MHz	Reading Level dBuV/m	Correct Factor dB	Measure ment dBuV/m	Limit dBuV/m	Margin dB	Detector	Comment
1 *	10356.4500	35.88	14.84	50.72	68.30	-17.58	Peak	

Orthogonal Axis:	X
Test Mode:	UNII-1/ TX AC20 Mode 5180MHz

Horizontal

130 dBuV/m

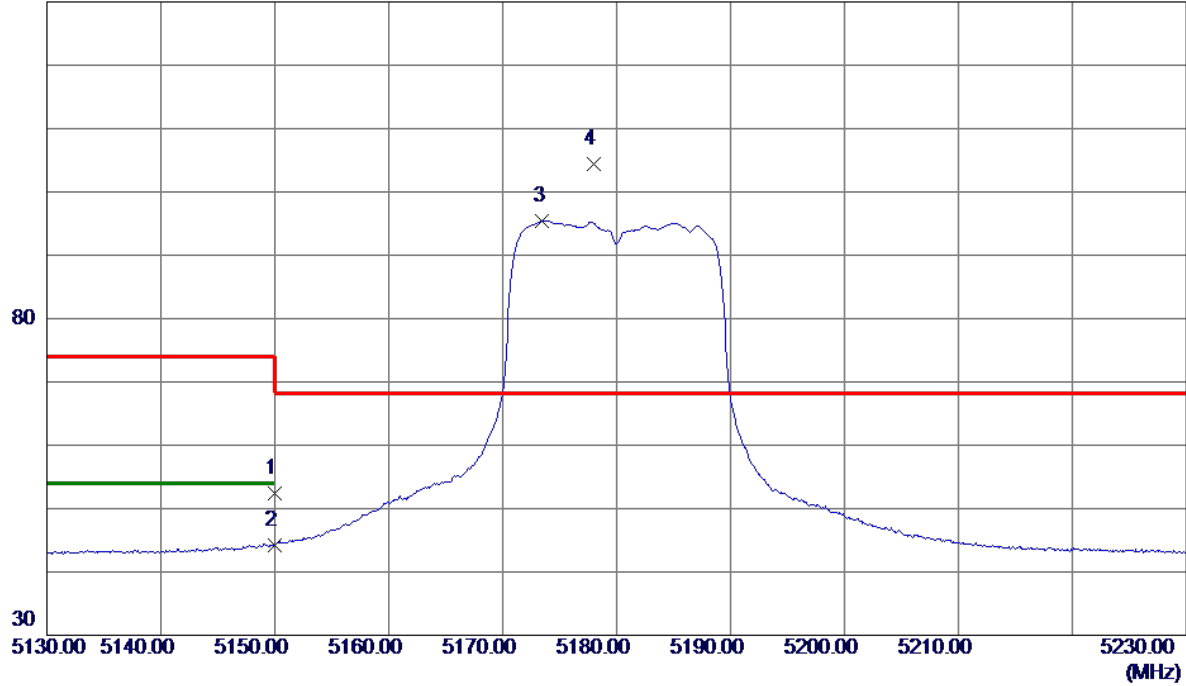

No.	Freq. MHz	Reading Level dBuV/m	Correct Factor dB	Measure ment dBuV/m	Limit dBuV/m	Margin dB	Detector	Comment
1	5150.0000	35.75	16.65	52.40	74.00	-21.60	Peak	
2	5150.0000	27.63	16.65	44.28	54.00	-9.72	AVG	
3	5173.5000	78.78	16.71	95.49	999.00	-903.51	AVG	No Limit
4 *	5178.0000	87.75	16.73	104.48	68.30	36.18	Peak	No Limit

Orthogonal Axis:	X
Test Mode:	UNII-1/ TX AC20 Mode 5180MHz

Horizontal

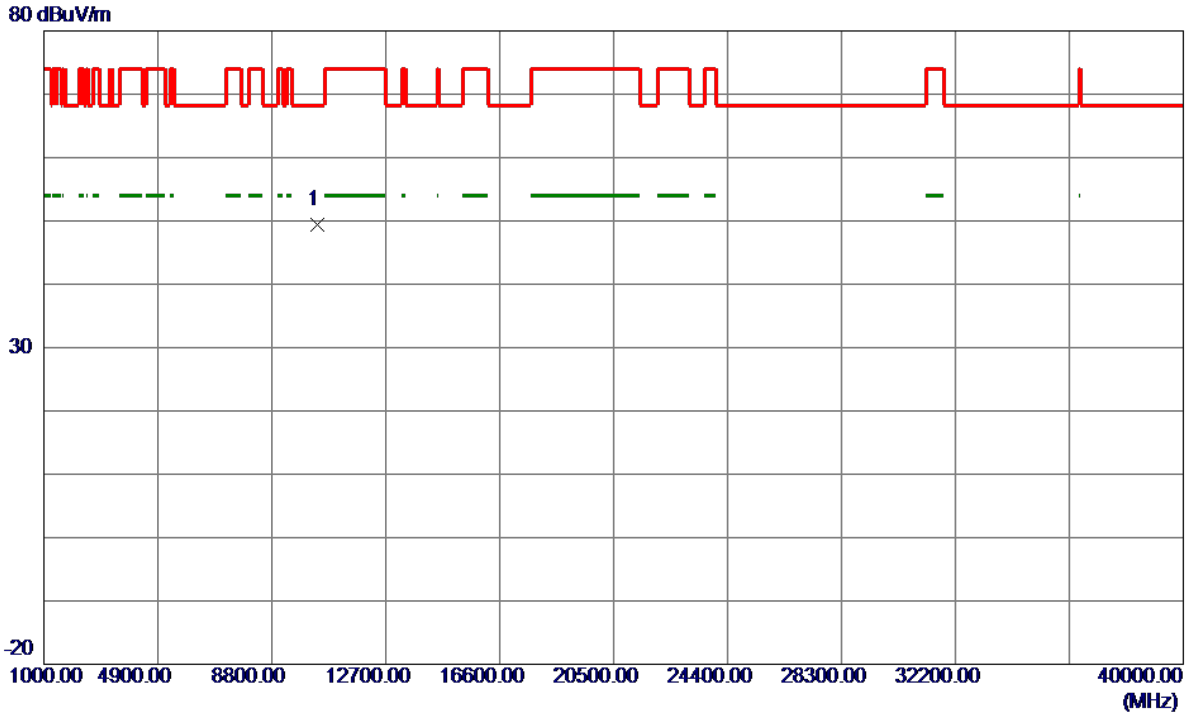

No.	Freq. MHz	Reading Level dBuV/m	Correct Factor dB	Measure ment dBuV/m	Limit dBuV/m	Margin dB	Detector	Comment
1 *	10361.9500	34.62	14.85	49.47	68.30	-18.83	Peak	

Orthogonal Axis:	X
Test Mode:	UNII-1/ TX AC20 Mode 5200MHz

Vertical

130 dBuV/m

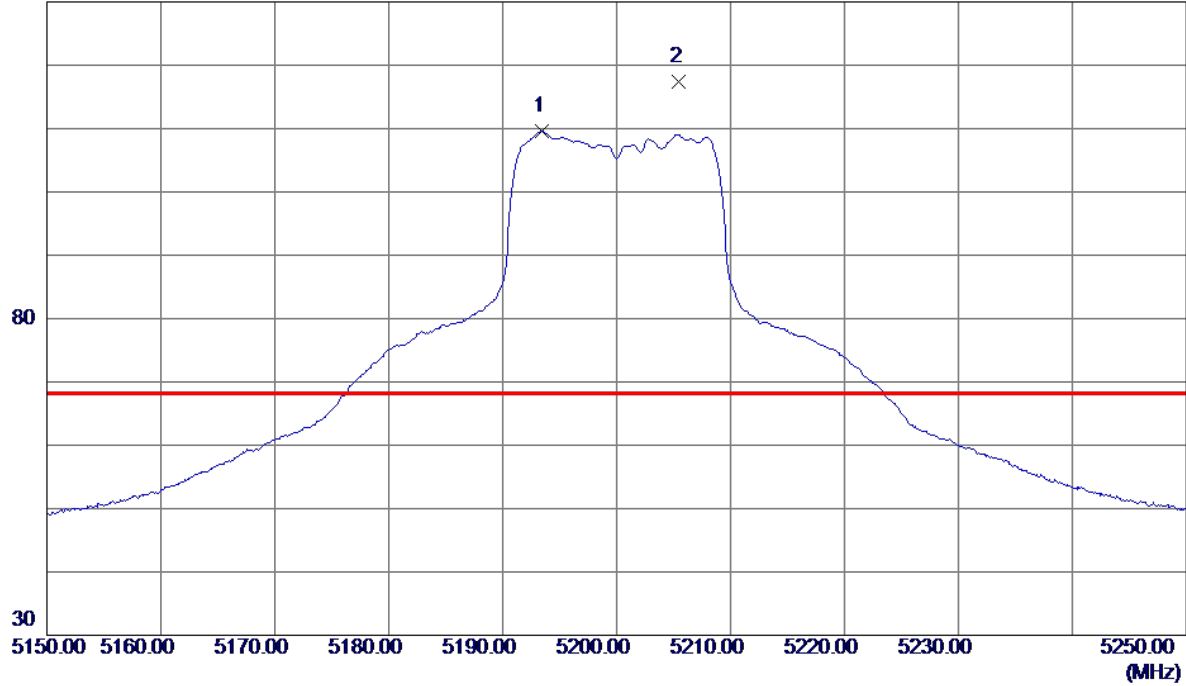

No.	Freq. MHz	Reading Level dBuV/m	Correct Factor dB	Measure ment dBuV/m	Limit dBuV/m	Margin dB	Detector	Comment
1	5193.5000	92.92	16.77	109.69	999.00	-889.31	AVG	No Limit
2 *	5205.5000	100.67	16.80	117.47	68.30	49.17	Peak	No Limit

Orthogonal Axis:	X
Test Mode:	UNII-1/ TX AC20 Mode 5200MHz

Vertical

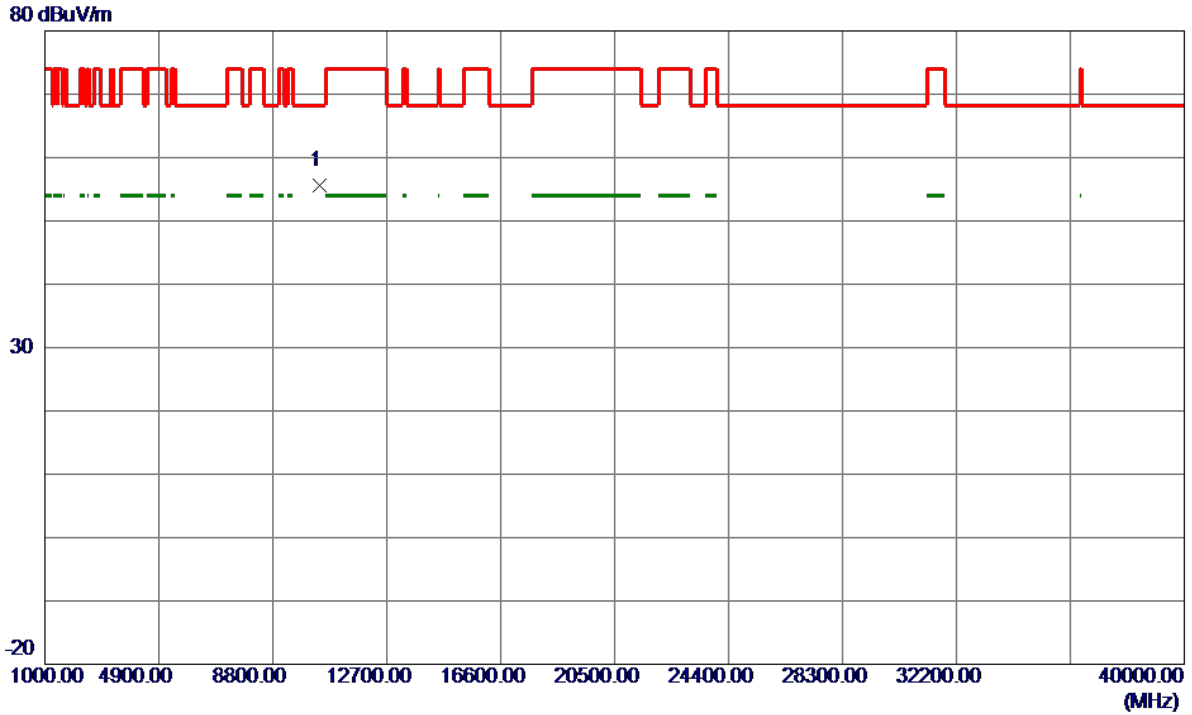

No.	Freq. MHz	Reading Level dBuV/m	Correct Factor dB	Measure ment dBuV/m	Limit dBuV/m	Margin dB	Detector	Comment
1 *	10409.8000	40.69	14.94	55.63	68.30	-12.67	Peak	

Orthogonal Axis:	X
Test Mode:	UNII-1/ TX AC20 Mode 5200MHz

Horizontal

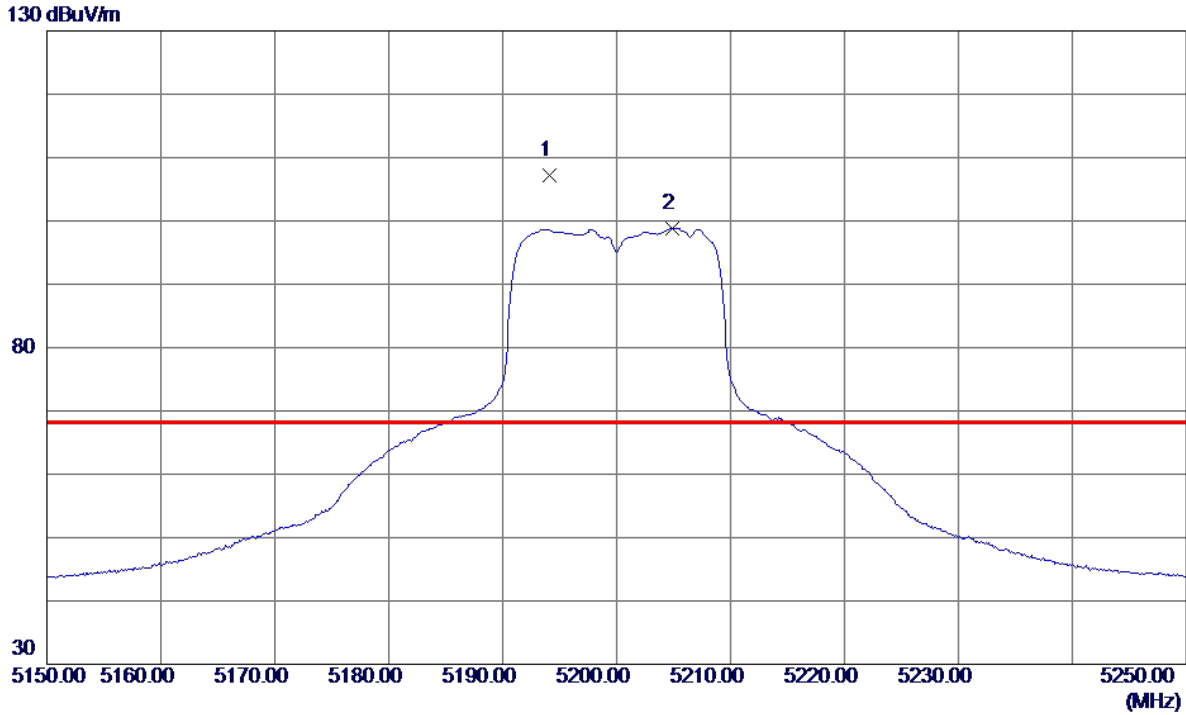

No.	Freq. MHz	Reading Level dBuV/m	Correct Factor dB	Measure ment dBuV/m	Limit dBuV/m	Margin dB	Detector	Comment
1 *	5194.1000	90.50	16.77	107.27	68.30	38.97	Peak	No Limit
2	5204.9000	82.05	16.80	98.85	999.00	-900.15	AVG	No Limit

Orthogonal Axis:	X
Test Mode:	UNII-1/ TX AC20 Mode 5200MHz

Horizontal

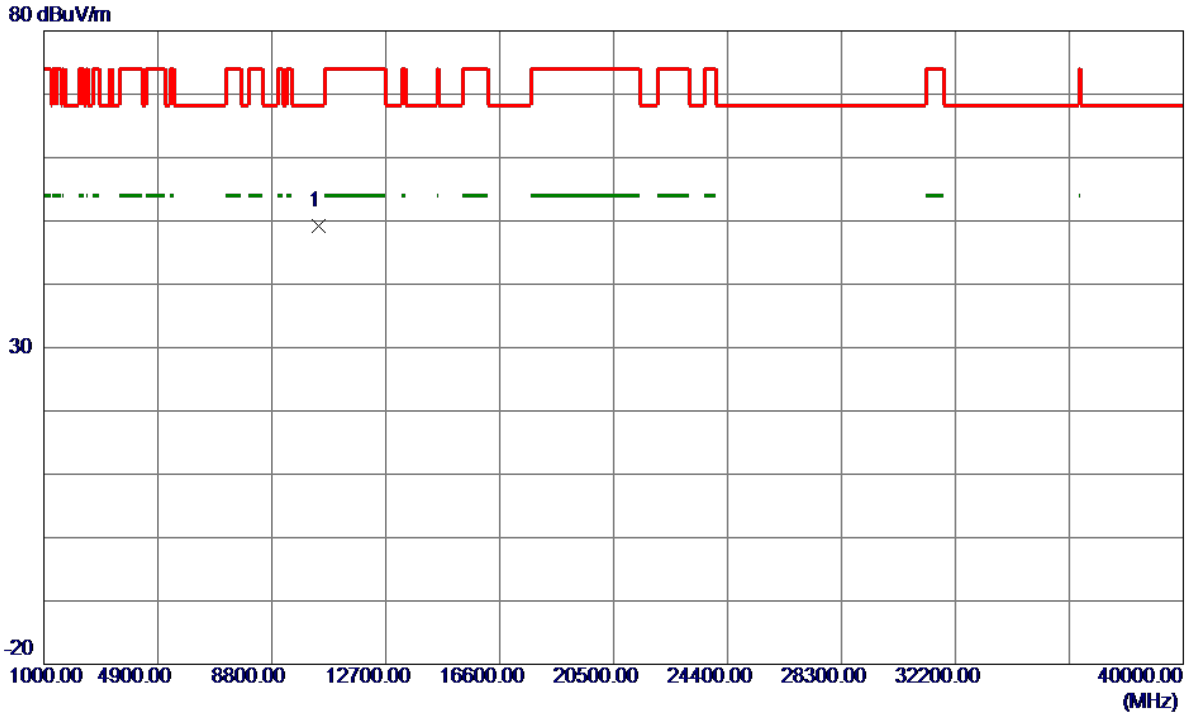

No.	Freq. MHz	Reading Level dBuV/m	Correct Factor dB	Measure ment dBuV/m	Limit dBuV/m	Margin dB	Detector	Comment
1 *	10400.9500	34.33	14.92	49.25	68.30	-19.05	Peak	

Orthogonal Axis:	X
Test Mode:	UNII-1/ TX AC20 Mode 5240MHz

Vertical

130 dBuV/m

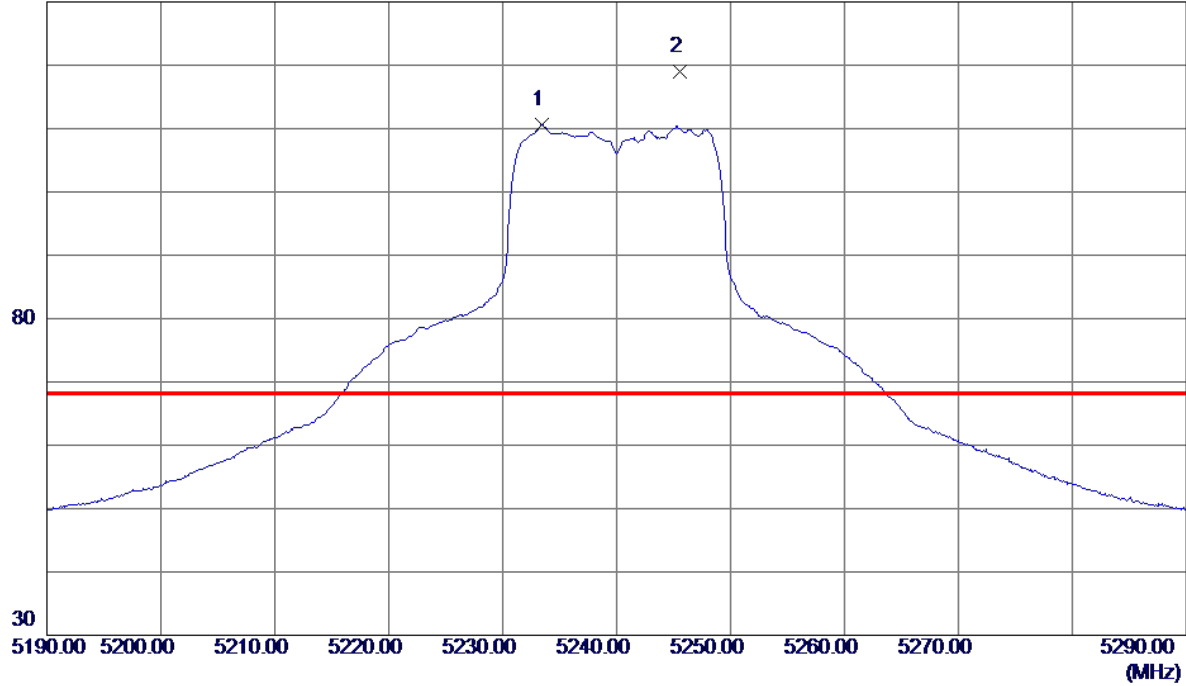

No.	Freq. MHz	Reading Level dBuV/m	Correct Factor dB	Measure ment dBuV/m	Limit dBuV/m	Margin dB	Detector	Comment
1	5233.4000	93.79	16.88	110.67	999.00	-888.33	AVG	No Limit
2 *	5245.6000	102.10	16.92	119.02	68.30	50.72	Peak	No Limit

Orthogonal Axis:	X
Test Mode:	UNII-1/ TX AC20 Mode 5240MHz

Vertical

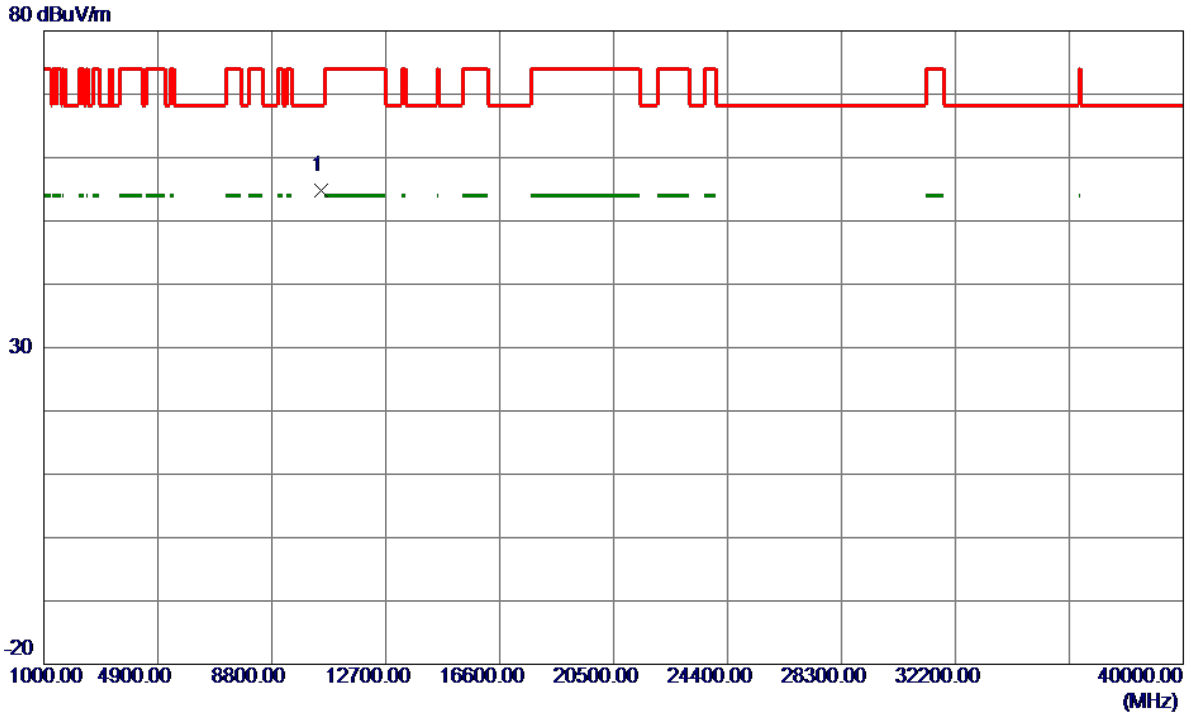

No.	Freq. MHz	Reading Level dBuV/m	Correct Factor dB	Measure ment dBuV/m	Limit dBuV/m	Margin dB	Detector	Comment
1 *	10477.7500	39.66	15.06	54.72	68.30	-13.58	Peak	

Orthogonal Axis:	X
Test Mode:	UNII-1/ TX AC20 Mode 5240MHz

Horizontal

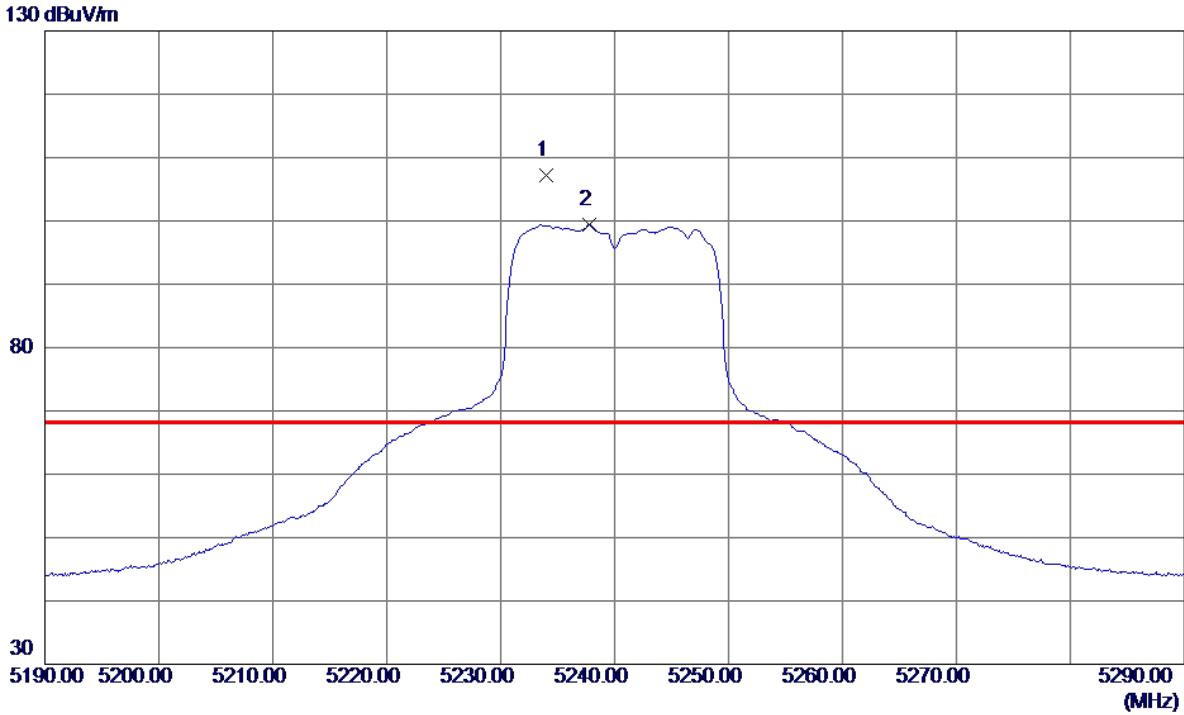

No.	Freq. MHz	Reading Level dBuV/m	Correct Factor dB	Measure ment dBuV/m	Limit dBuV/m	Margin dB	Detector	Comment
1 *	5234.0000	90.32	16.88	107.20	68.30	38.90	Peak	No Limit
2	5237.8000	82.58	16.90	99.48	999.00	-899.52	AVG	No Limit

Orthogonal Axis:	X
Test Mode:	UNII-1/ TX AC20 Mode 5240MHz

Horizontal

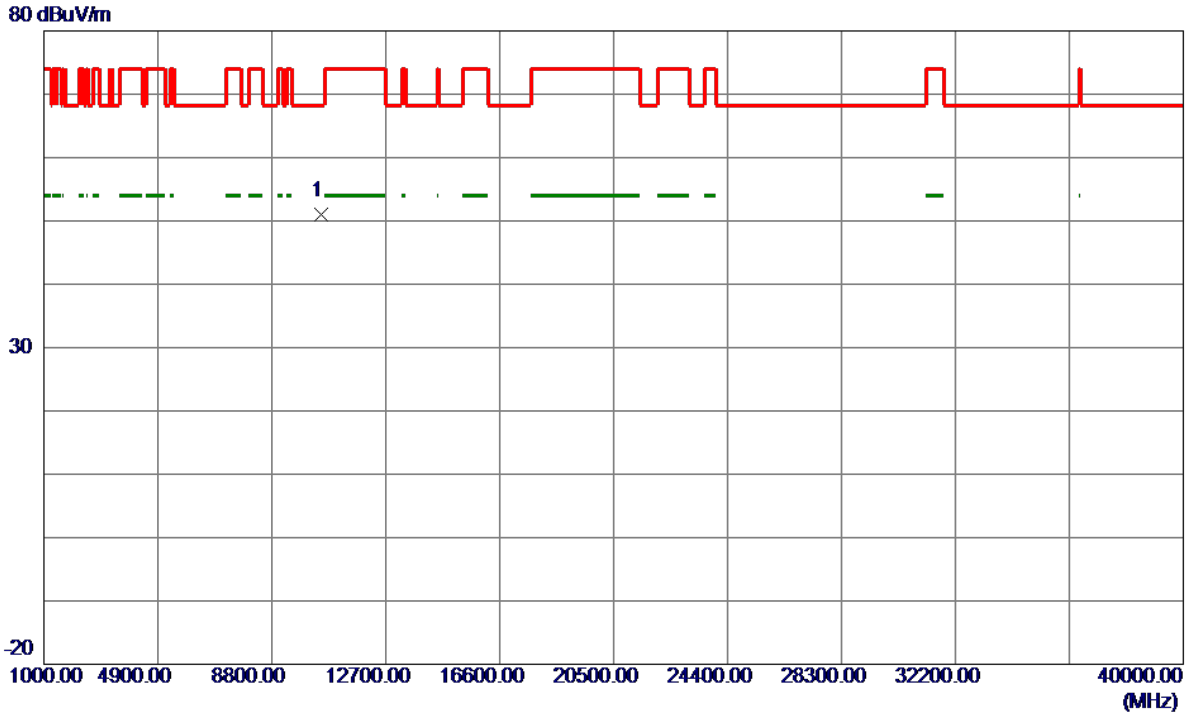

No.	Freq. MHz	Reading Level dBuV/m	Correct Factor dB	Measure ment dBuV/m	Limit dBuV/m	Margin dB	Detector	Comment
1 *	10483.7000	35.83	15.07	50.90	68.30	-17.40	Peak	

Orthogonal Axis:	X
Test Mode:	UNII-1/ TX AC40 Mode 5190MHz

Vertical

130 dBuV/m

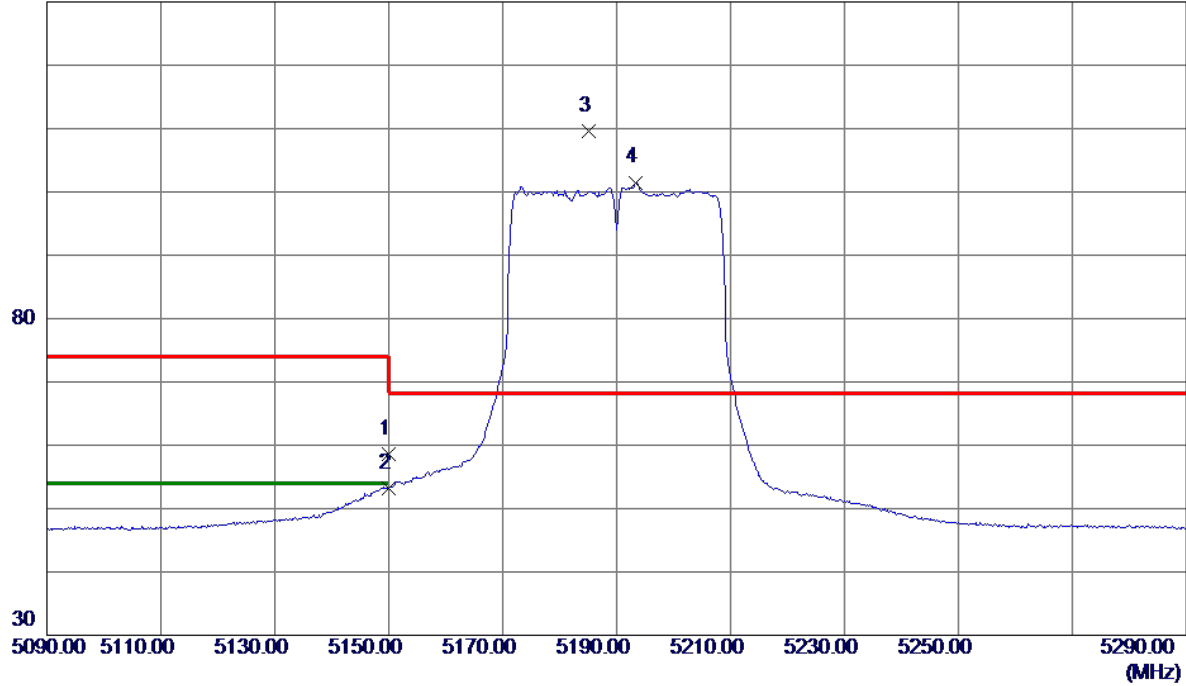

No.	Freq. MHz	Reading Level dBuV/m	Correct Factor dB	Measure ment dBuV/m	Limit dBuV/m	Margin dB	Detector	Comment
1	5150.0000	42.02	16.65	58.67	74.00	-15.33	Peak	
2	5150.0000	36.62	16.65	53.27	54.00	-0.73	AVG	
3 *	5185.2000	92.90	16.75	109.65	68.30	41.35	Peak	No Limit
4	5193.4000	84.73	16.77	101.50	999.00	-897.50	AVG	No Limit

Orthogonal Axis:	X
Test Mode:	UNII-1/ TX AC40 Mode 5190MHz

Vertical

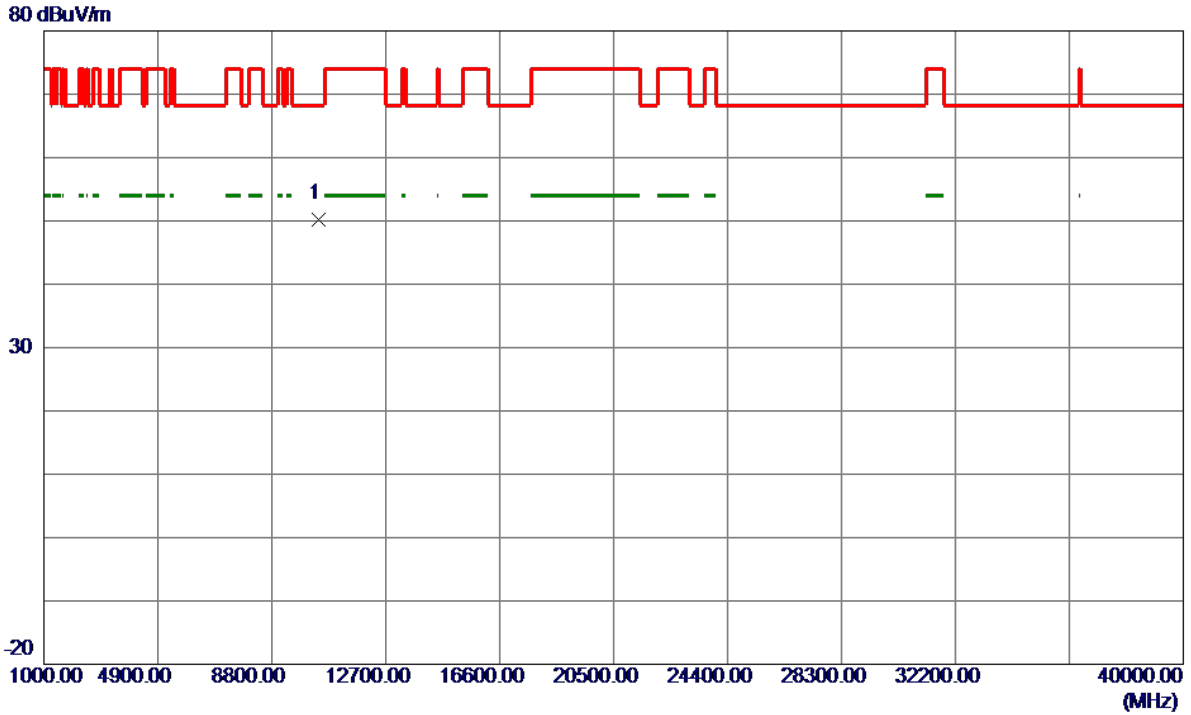

No.	Freq. MHz	Reading Level dBuV/m	Correct Factor dB	Measure ment dBuV/m	Limit dBuV/m	Margin dB	Detector	Comment
1 *	10388.8500	35.40	14.90	50.30	68.30	-18.00	Peak	

Orthogonal Axis:	X
Test Mode:	UNII-1/ TX AC40 Mode 5190MHz

Horizontal

130 dBuV/m

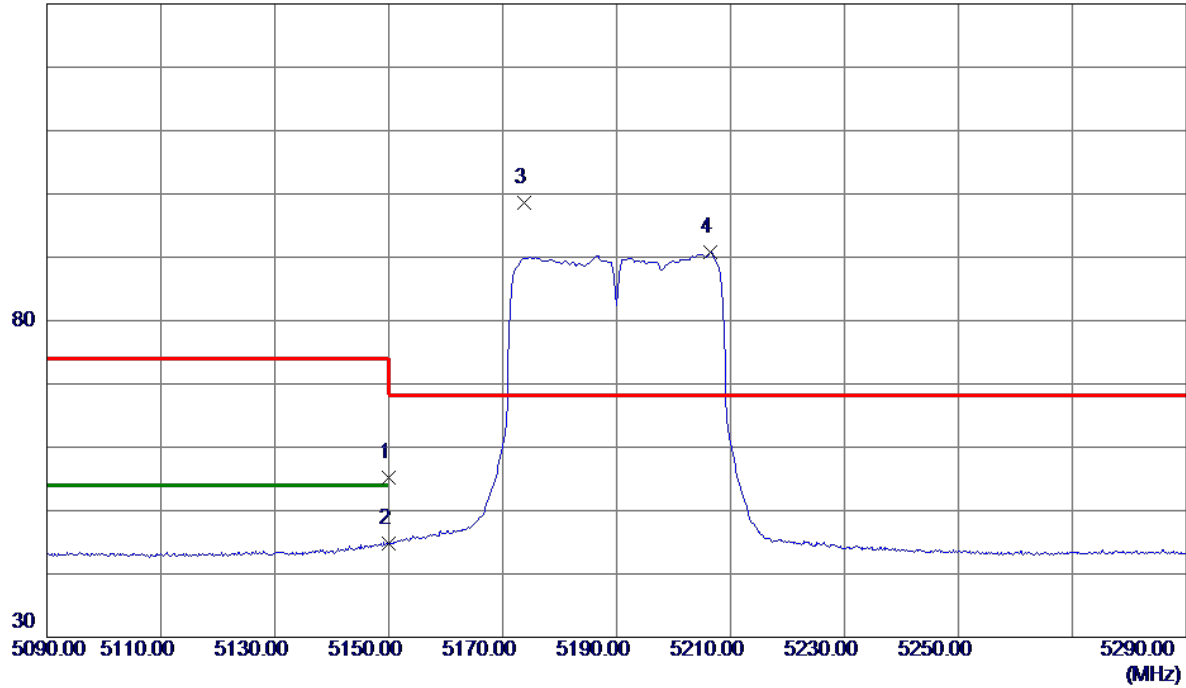

No.	Freq. MHz	Reading Level dBuV/m	Correct Factor dB	Measure ment dBuV/m	Limit dBuV/m	Margin dB	Detector	Comment
1	5150.0000	38.51	16.65	55.16	74.00	-18.84	Peak	
2	5150.0000	28.21	16.65	44.86	54.00	-9.14	AVG	
3 *	5173.8000	81.86	16.71	98.57	68.30	30.27	Peak	No Limit
4	5206.4000	74.05	16.81	90.86	999.00	-908.14	AVG	No Limit

Orthogonal Axis:	X
Test Mode:	UNII-1/ TX AC40 Mode 5190MHz

Horizontal

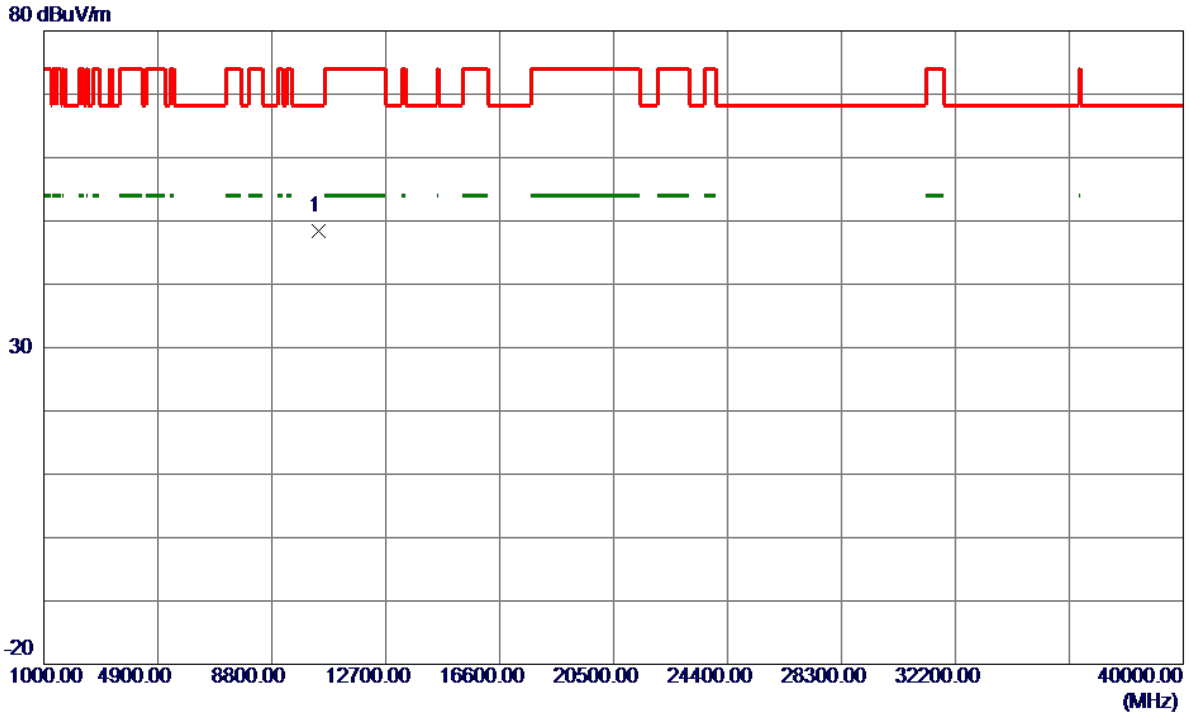

No.	Freq. MHz	Reading Level dBuV/m	Correct Factor dB	Measure ment dBuV/m	Limit dBuV/m	Margin dB	Detector	Comment
1 *	10397.3500	33.41	14.91	48.32	68.30	-19.98	Peak	

Orthogonal Axis:	X
Test Mode:	UNII-1/ TX AC40 Mode 5230MHz

Vertical

130 dBuV/m

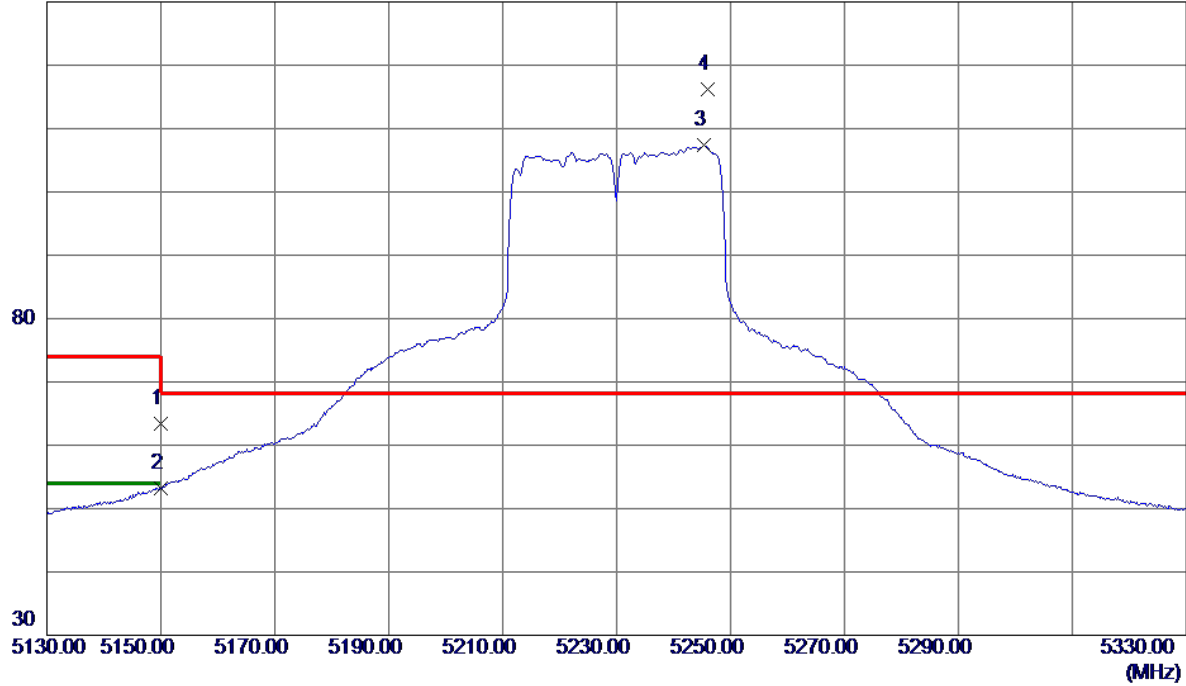

No.	Freq. MHz	Reading Level dBuV/m	Correct Factor dB	Measure ment dBuV/m	Limit dBuV/m	Margin dB	Detector	Comment
1	5150.0000	46.69	16.65	63.34	74.00	-10.66	Peak	
2	5150.0000	36.51	16.65	53.16	54.00	-0.84	AVG	
3	5245.4000	90.39	16.92	107.31	999.00	-891.69	AVG	No Limit
4 *	5246.0000	99.24	16.92	116.16	68.30	47.86	Peak	No Limit

Orthogonal Axis:	X
Test Mode:	UNII-1/ TX AC40 Mode 5230MHz

Vertical

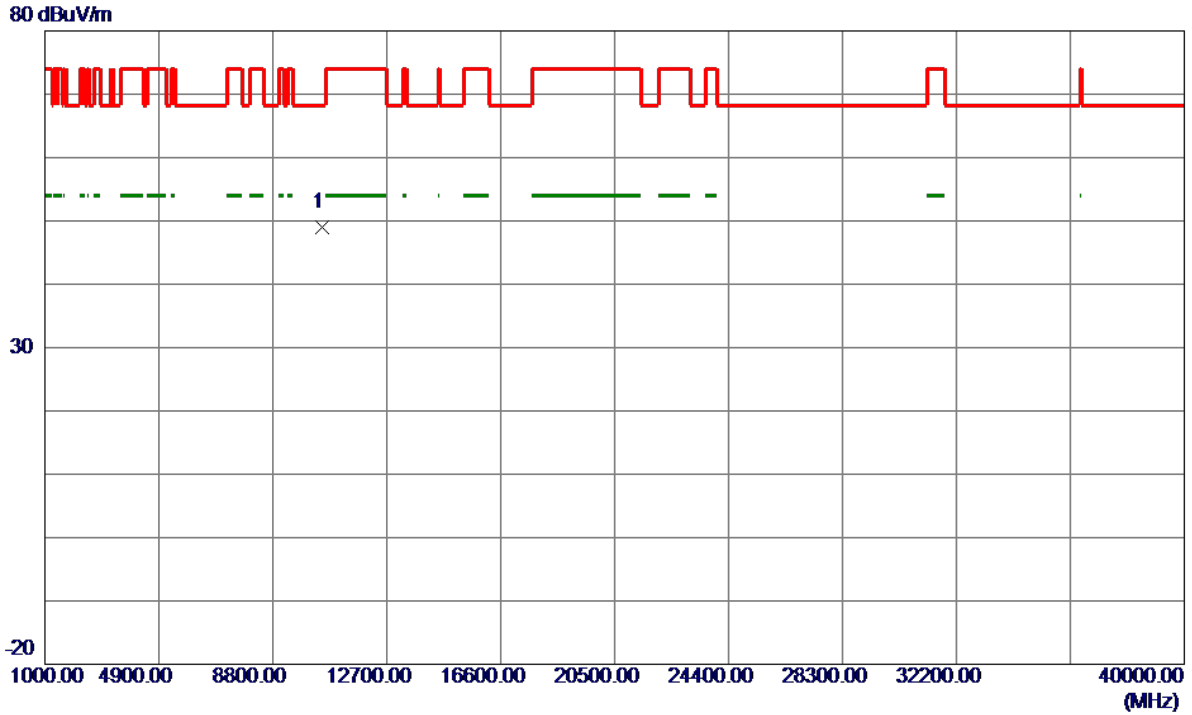

No.	Freq. MHz	Reading Level dBuV/m	Correct Factor dB	Measure ment dBuV/m	Limit dBuV/m	Margin dB	Detector	Comment
1 *	10477.6500	33.92	15.06	48.98	68.30	-19.32	Peak	

Orthogonal Axis:	X
Test Mode:	UNII-1/ TX AC40 Mode 5230MHz

Horizontal

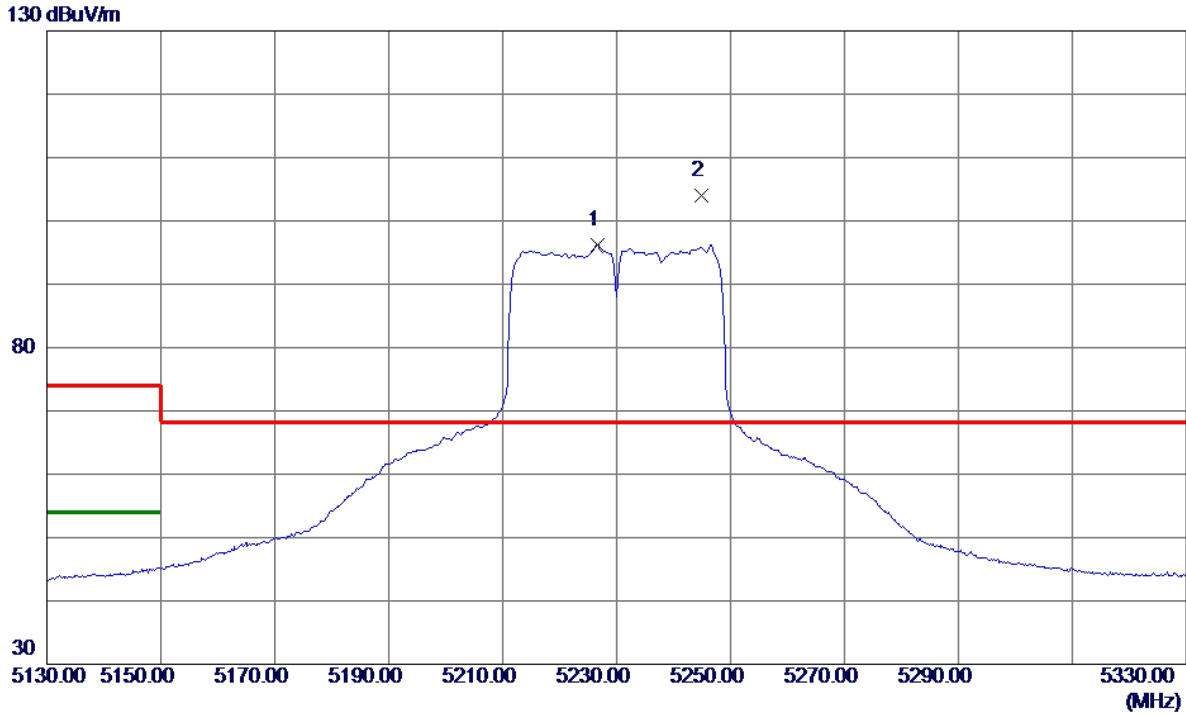

No.	Freq. MHz	Reading Level dBuV/m	Correct Factor dB	Measure ment dBuV/m	Limit dBuV/m	Margin dB	Detector	Comment
1	5226.6000	79.33	16.86	96.19	999.00	-902.81	AVG	No Limit
2 *	5244.8000	87.05	16.92	103.97	68.30	35.67	Peak	No Limit

Orthogonal Axis:	X
Test Mode:	UNII-1/ TX AC40 Mode 5230MHz

Horizontal

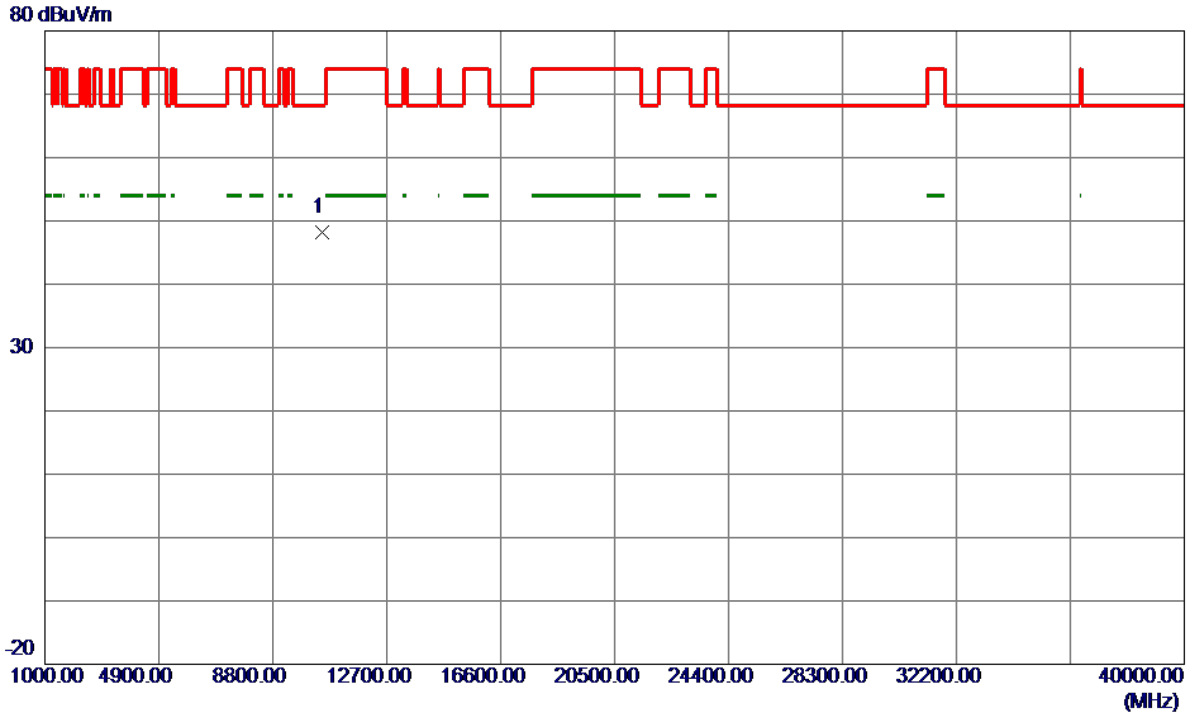

No.	Freq. MHz	Reading Level dBuV/m	Correct Factor dB	Measure ment dBuV/m	Limit dBuV/m	Margin dB	Detector	Comment
1 *	10472.5500	33.13	15.05	48.18	68.30	-20.12	Peak	

Orthogonal Axis:	X
Test Mode:	UNII-1/ TX AC80 Mode 5210MHz

Vertical

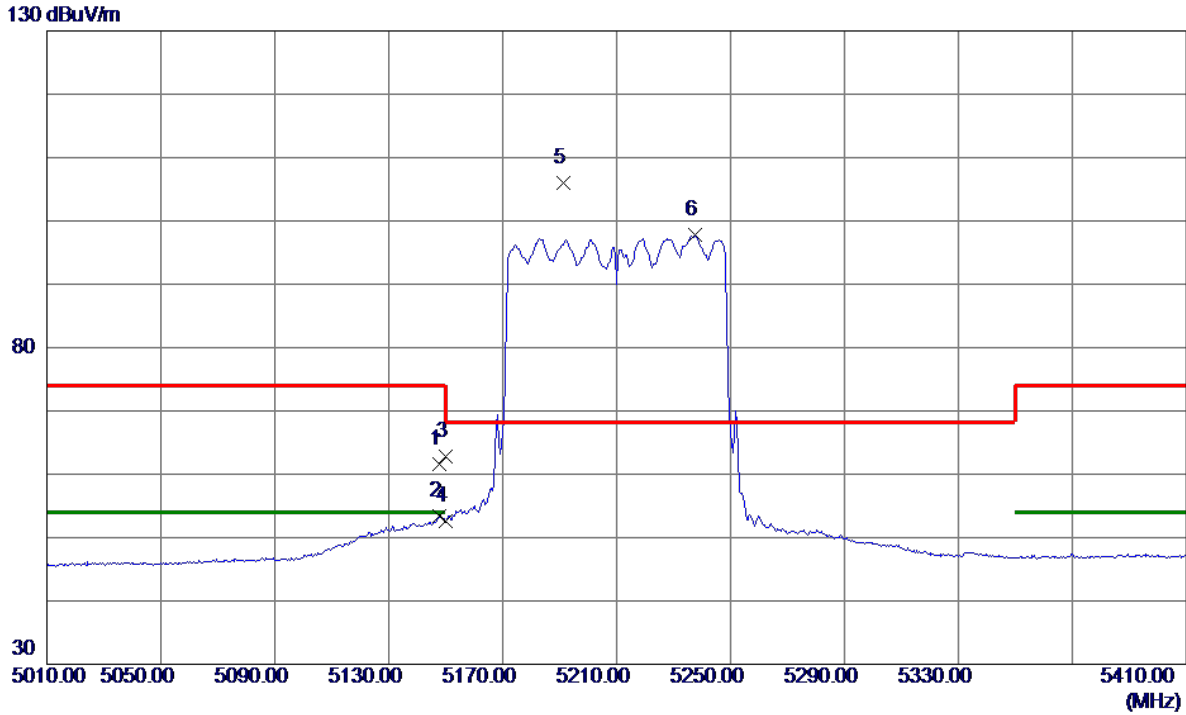

No.	Freq. MHz	Reading Level dBuV/m	Correct Factor dB	Measure ment dBuV/m	Limit dBuV/m	Margin dB	Detector	Comment
1	5147.6000	44.95	16.64	61.59	74.00	-12.41	Peak	
2	5147.6000	36.84	16.64	53.48	54.00	-0.52	AVG	
3	5150.0000	46.08	16.65	62.73	74.00	-11.27	Peak	
4	5150.0000	35.98	16.65	52.63	54.00	-1.37	AVG	
5 *	5191.2000	89.30	16.76	106.06	68.30	37.76	Peak	No Limit
6	5237.6000	80.82	16.89	97.71	999.00	-901.29	AVG	No Limit

Orthogonal Axis:	X
Test Mode:	UNII-1/ TX AC80 Mode 5210MHz

Vertical

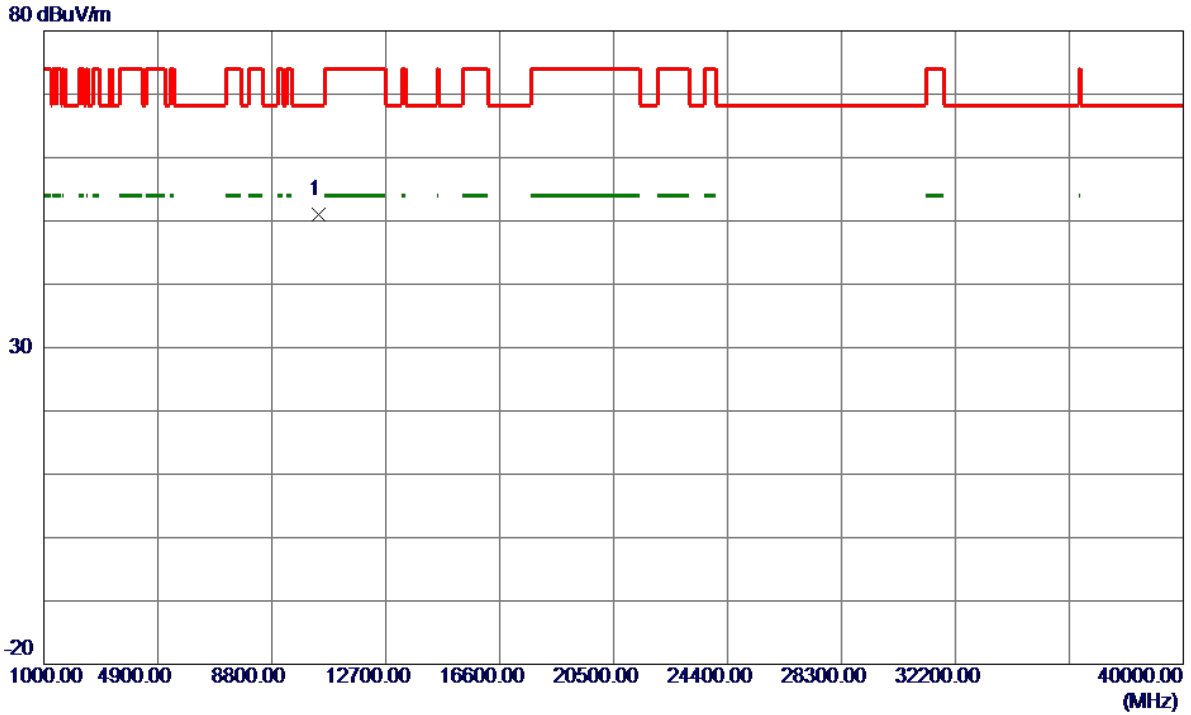

No.	Freq. MHz	Reading Level dBuV/m	Correct Factor dB	Measure ment dBuV/m	Limit dBuV/m	Margin dB	Detector	Comment
1 *	10416.3000	36.05	14.95	51.00	68.30	-17.30	Peak	

Orthogonal Axis:	X
Test Mode:	UNII-1/ TX AC80 Mode 5210MHz

Horizontal

130 dBuV/m

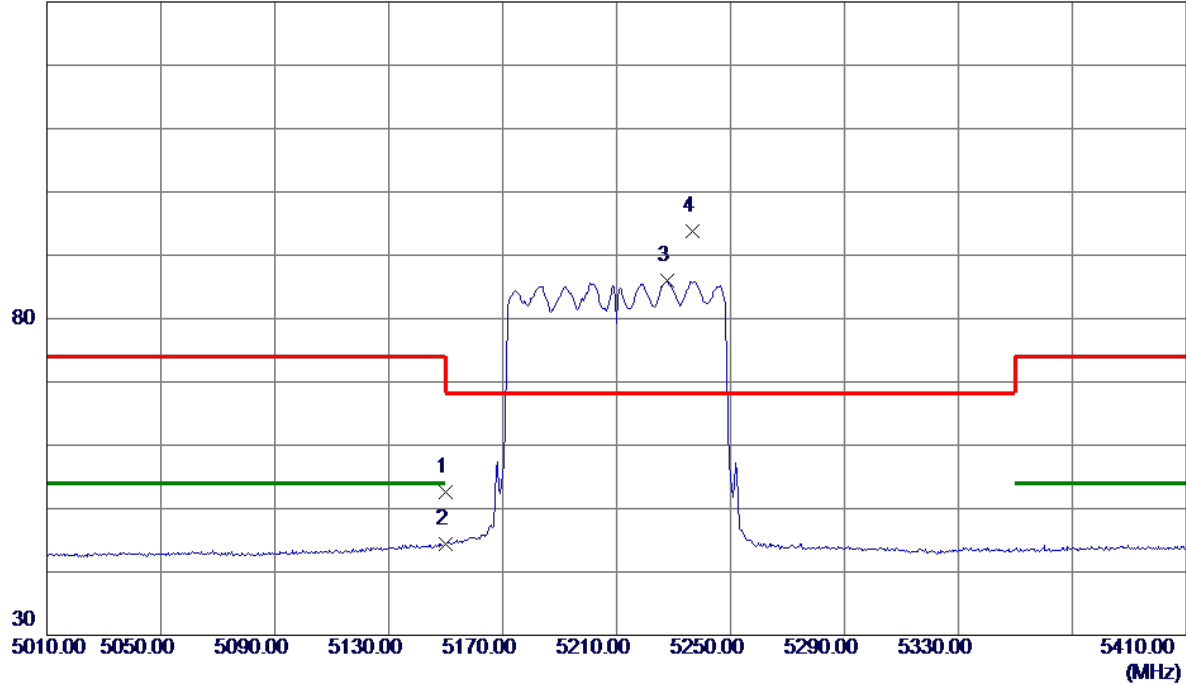

No.	Freq. MHz	Reading Level dBuV/m	Correct Factor dB	Measure ment dBuV/m	Limit dBuV/m	Margin dB	Detector	Comment
1	5150.0000	35.90	16.65	52.55	74.00	-21.45	Peak	
2	5150.0000	27.73	16.65	44.38	54.00	-9.62	AVG	
3	5227.6000	69.08	16.87	85.95	999.00	-913.05	AVG	No Limit
4 *	5236.8000	76.89	16.89	93.78	68.30	25.48	Peak	No Limit

Orthogonal Axis:	X
Test Mode:	UNII-1/ TX AC80 Mode 5210MHz

Horizontal

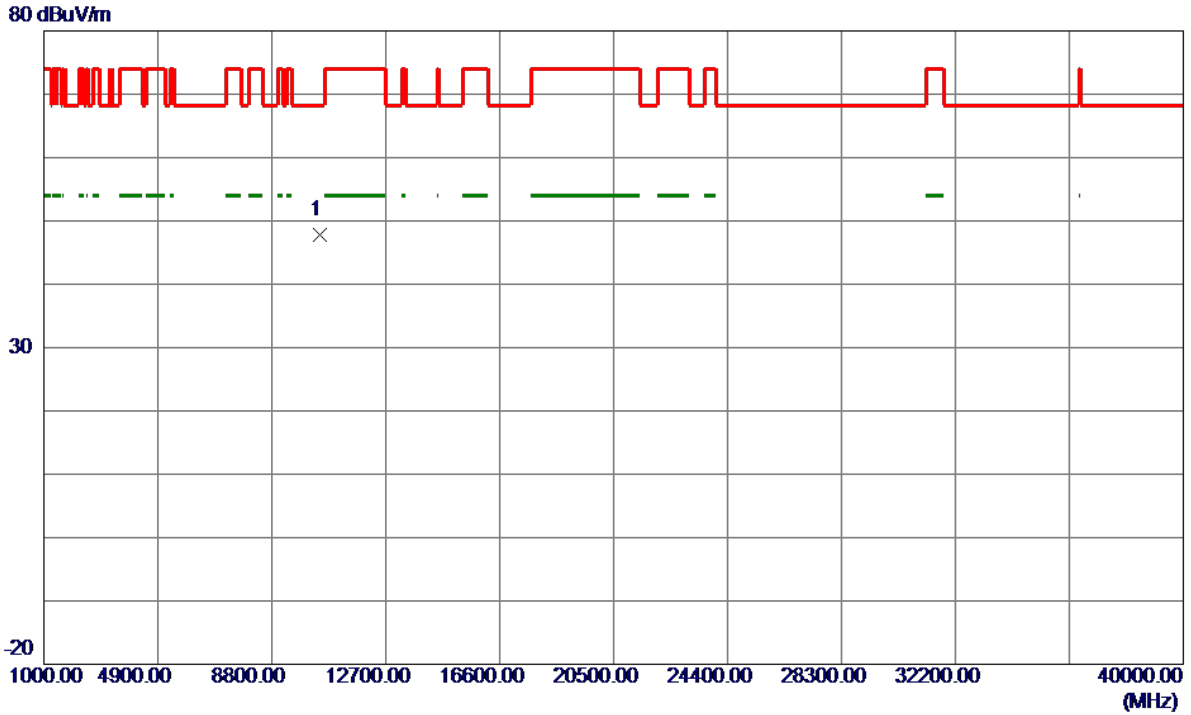

No.	Freq. MHz	Reading Level dBuV/m	Correct Factor dB	Measure ment dBuV/m	Limit dBuV/m	Margin dB	Detector	Comment
1 *	10425.9000	32.84	14.96	47.80	68.30	-20.50	Peak	

Orthogonal Axis:	X
Test Mode:	UNII-3/TX AC20 Mode 5745MHz

Vertical

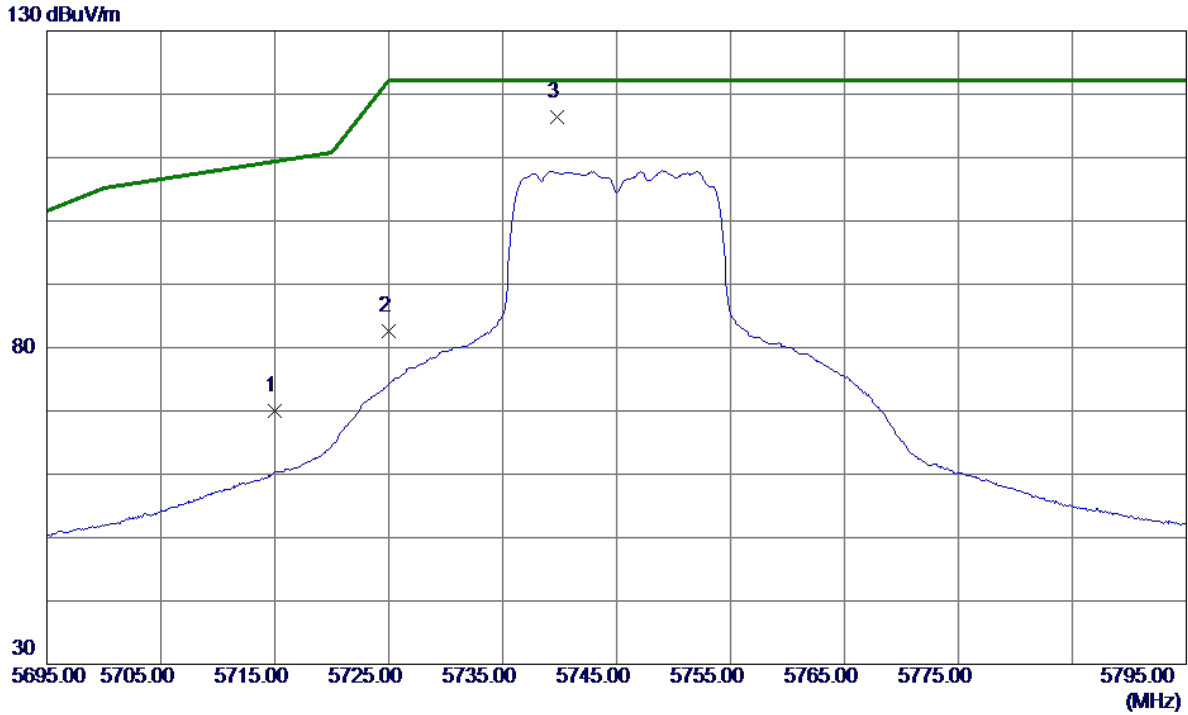

No.	Freq. MHz	Reading Level dBuV/m	Correct Factor dB	Measure ment dBuV/m	Limit dBuV/m	Margin dB	Detector	Comment
1	5715.0000	51.66	18.40	70.06	109.40	-39.34	Peak	
2	5725.0000	64.13	18.44	82.57	122.20	-39.63	Peak	
3 *	5739.8000	97.87	18.49	116.36	122.20	-5.84	Peak	

Orthogonal Axis:	X
Test Mode:	UNII-3/TX AC20 Mode 5745MHz

Vertical

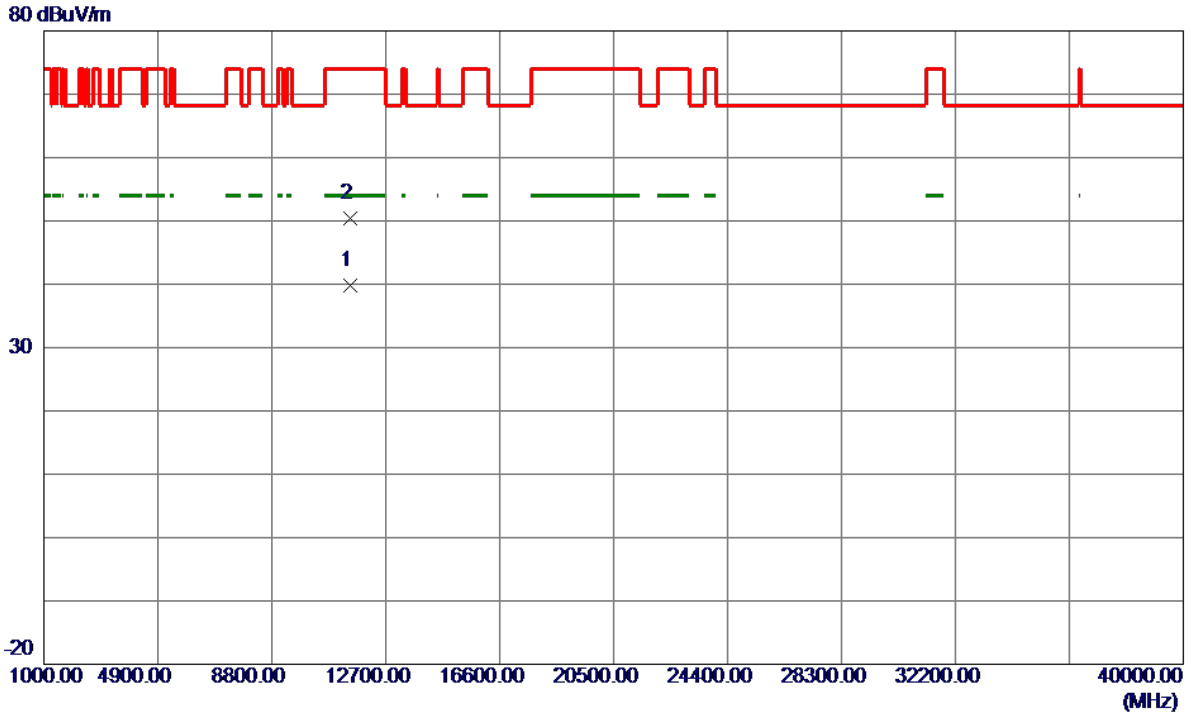

No.	Freq. MHz	Reading Level dBuV/m	Correct Factor dB	Measure ment dBuV/m	Limit dBuV/m	Margin dB	Detector	Comment
1 *	11486.5500	23.83	15.94	39.77	54.00	-14.23	AVG	
2	11494.8500	34.53	15.95	50.48	74.00	-23.52	Peak	

Orthogonal Axis:	X
Test Mode:	UNII-3/TX AC20 Mode 5745MHz

Horizontal

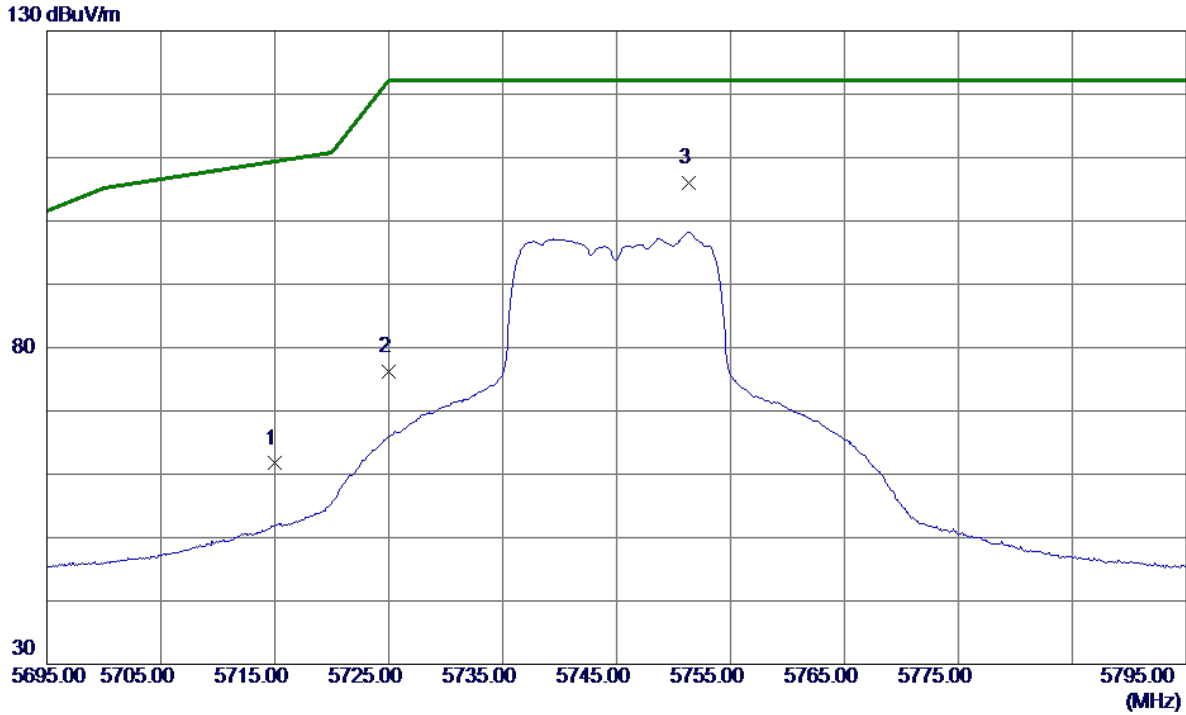

No.	Freq. MHz	Reading Level dBuV/m	Correct Factor dB	Measure ment dBuV/m	Limit dBuV/m	Margin dB	Detector	Comment
1	5715.0000	43.30	18.40	61.70	109.40	-47.70	Peak	
2	5725.0000	57.70	18.44	76.14	122.20	-46.06	Peak	
3 *	5751.3000	87.46	18.53	105.99	122.20	-16.21	Peak	

Orthogonal Axis:	X
Test Mode:	UNII-3/TX AC20 Mode 5745MHz

Horizontal

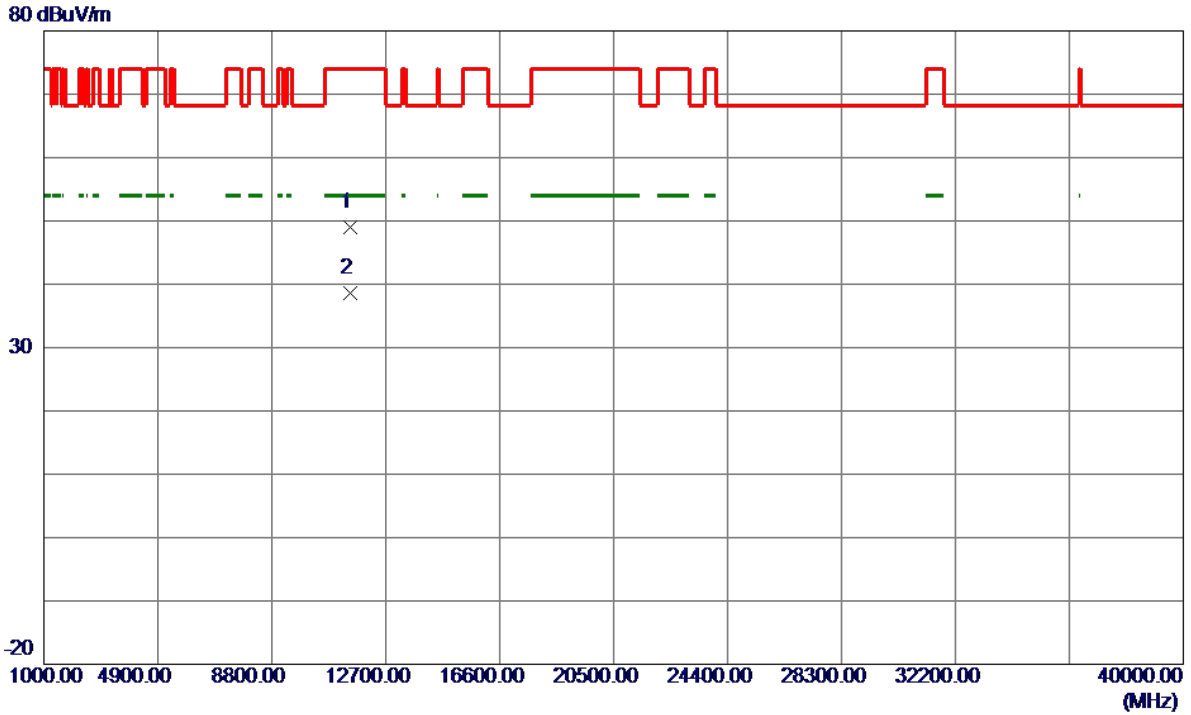

No.	Freq. MHz	Reading Level dBuV/m	Correct Factor dB	Measure ment dBuV/m	Limit dBuV/m	Margin dB	Detector	Comment
1	11482.7500	33.12	15.94	49.06	74.00	-24.94	Peak	
2 *	11492.2000	22.63	15.95	38.58	54.00	-15.42	AVG	

Orthogonal Axis:	X
Test Mode:	UNII-3/TX AC20 Mode 5785MHz

Vertical

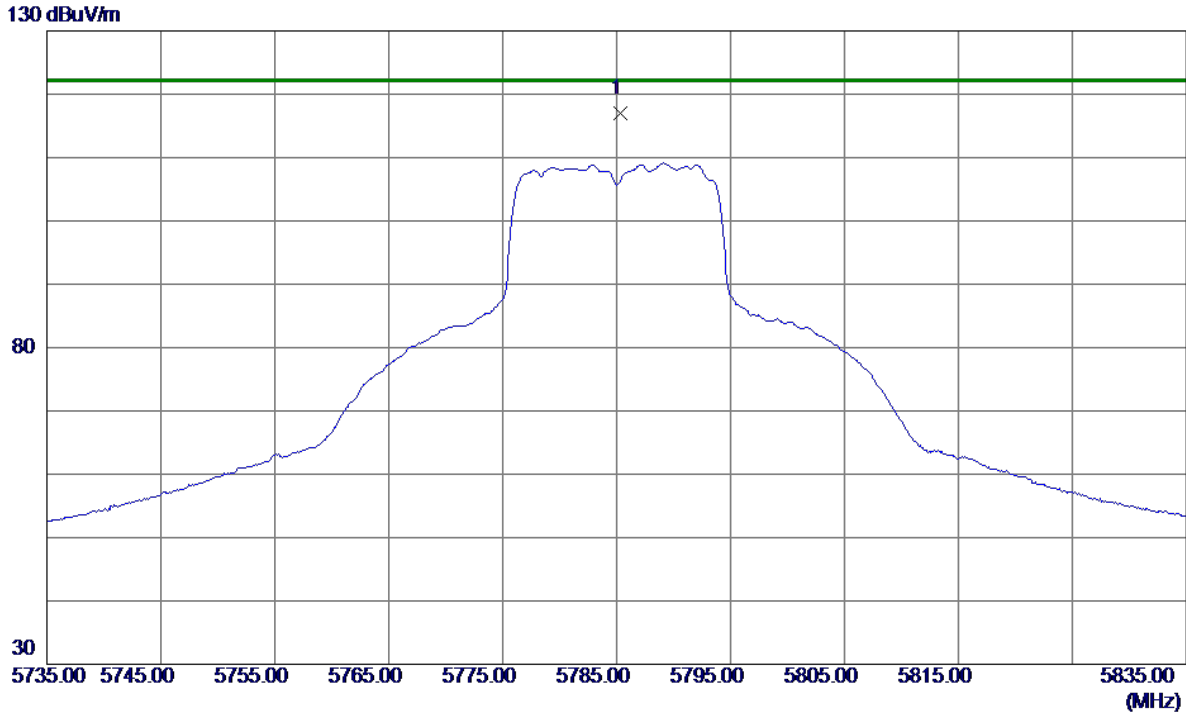

No.	Freq. MHz	Reading Level dBuV/m	Correct Factor dB	Measure ment dBuV/m	Limit dBuV/m	Margin dB	Detector	Comment
1 *	5785.3000	98.43	18.65	117.08	122.20	-5.12	Peak	

Orthogonal Axis:	X
Test Mode:	UNII-3/TX AC20 Mode 5785MHz

Vertical

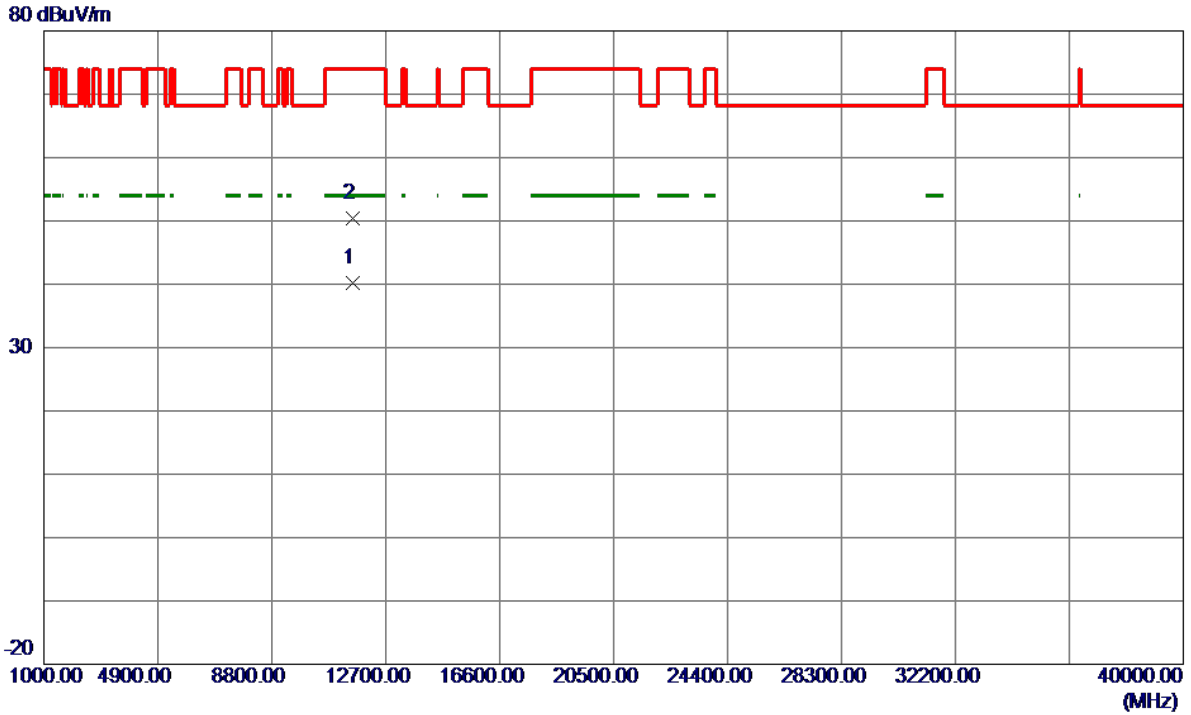

No.	Freq. MHz	Reading Level dBuV/m	Correct Factor dB	Measure ment dBuV/m	Limit dBuV/m	Margin dB	Detector	Comment
1 *	11572.4500	24.16	15.99	40.15	54.00	-13.85	AVG	
2	11574.8500	34.40	15.99	50.39	74.00	-23.61	Peak	

Orthogonal Axis:	X
Test Mode:	UNII-3/TX AC20 Mode 5785MHz

Horizontal

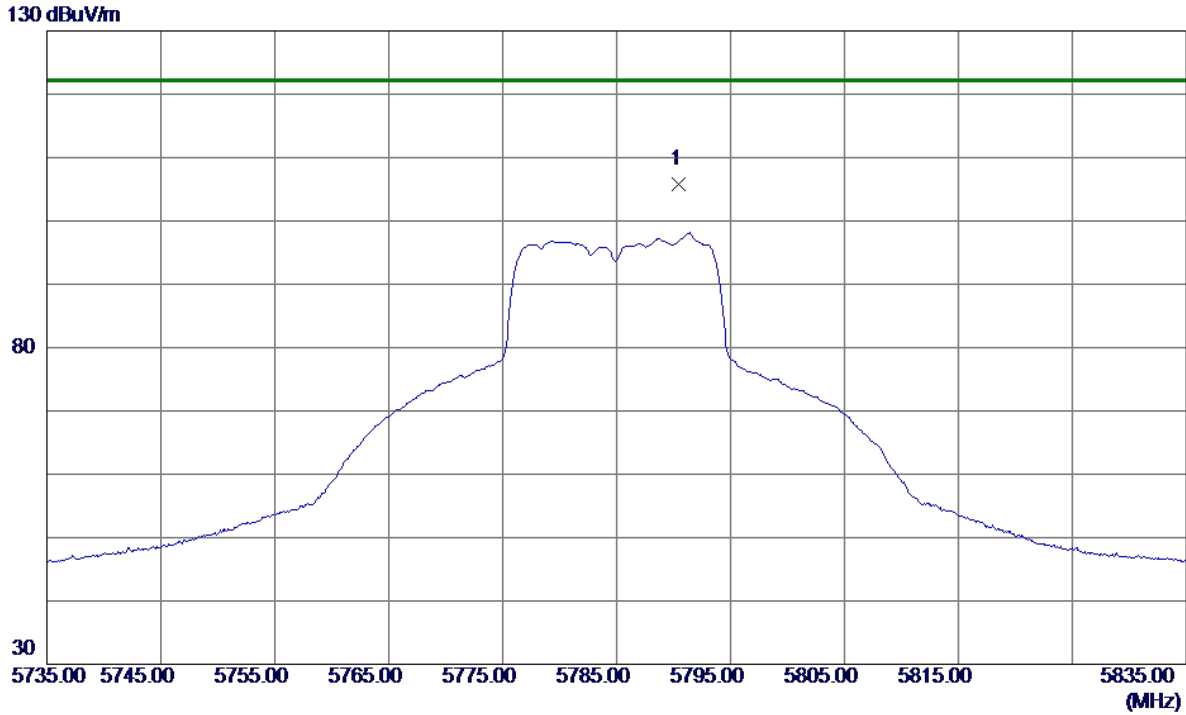

No.	Freq. MHz	Reading Level dBuV/m	Correct Factor dB	Measure ment dBuV/m	Limit dBuV/m	Margin dB	Detector	Comment
1 *	5790.5000	87.07	18.67	105.74	122.20	-16.46	Peak	

Orthogonal Axis:	X
Test Mode:	UNII-3/TX AC20 Mode 5785MHz

Horizontal

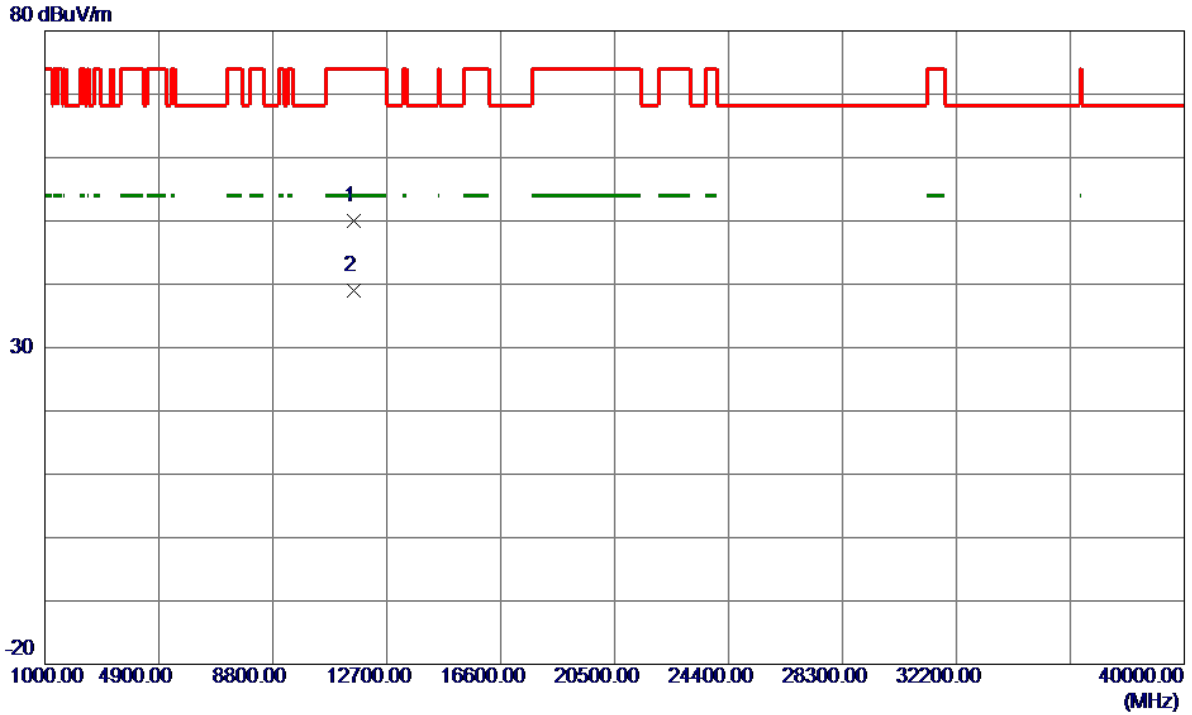

No.	Freq. MHz	Reading Level dBuV/m	Correct Factor dB	Measure ment dBuV/m	Limit dBuV/m	Margin dB	Detector	Comment
1	11567.7500	33.95	15.99	49.94	74.00	-24.06	Peak	
2 *	11568.6500	23.06	15.99	39.05	54.00	-14.95	AVG	

Orthogonal Axis:	X
Test Mode:	UNII-3/TX AC20 Mode 5825MHz

Vertical

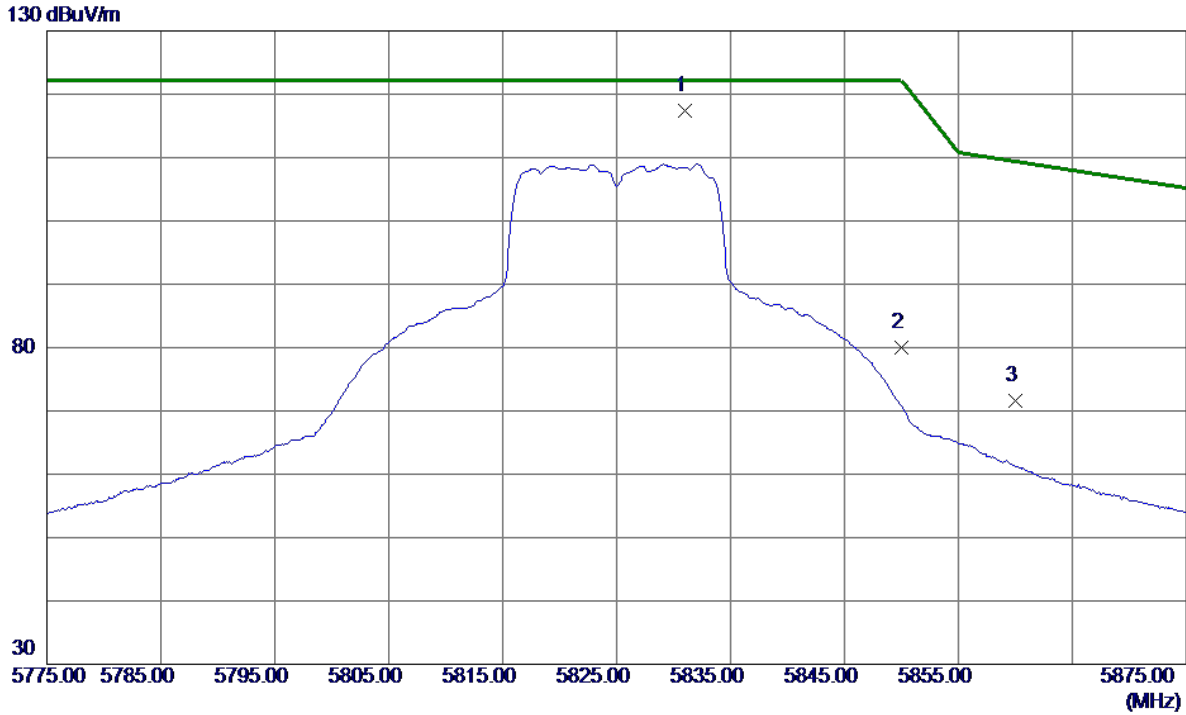

No.	Freq. MHz	Reading Level dBuV/m	Correct Factor dB	Measure ment dBuV/m	Limit dBuV/m	Margin dB	Detector	Comment
1 *	5831.0000	98.56	18.81	117.37	122.20	-4.83	Peak	
2	5850.0000	61.18	18.88	80.06	122.20	-42.14	Peak	
3	5860.0000	52.75	18.91	71.66	109.40	-37.74	Peak	

Orthogonal Axis:	X
Test Mode:	UNII-3/TX AC20 Mode 5825MHz

Vertical

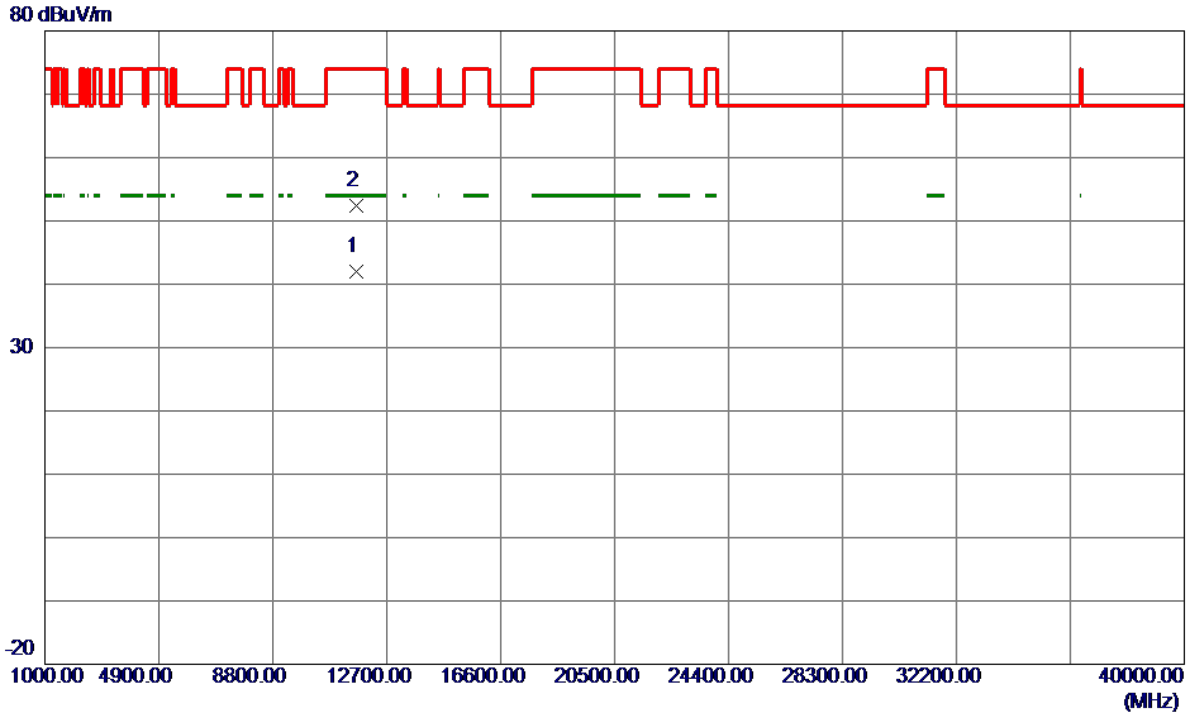

No.	Freq. MHz	Reading Level dBuV/m	Correct Factor dB	Measure ment dBuV/m	Limit dBuV/m	Margin dB	Detector	Comment
1 *	11648.2500	25.96	16.03	41.99	54.00	-12.01	AVG	
2	11650.5000	36.35	16.03	52.38	74.00	-21.62	Peak	

Orthogonal Axis:	X
Test Mode:	UNII-3/TX AC20 Mode 5825MHz

Horizontal

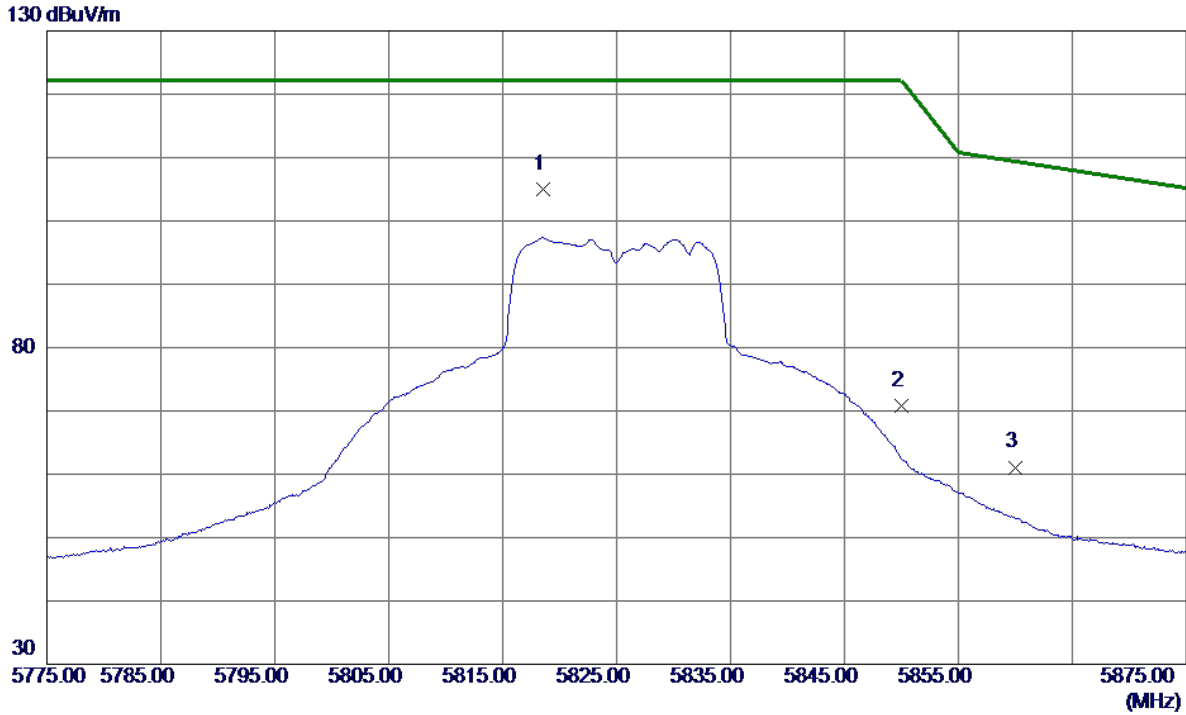

No.	Freq. MHz	Reading Level dBuV/m	Correct Factor dB	Measure ment dBuV/m	Limit dBuV/m	Margin dB	Detector	Comment
1 *	5818.6000	86.23	18.77	105.00	122.20	-17.20	Peak	
2	5850.0000	51.90	18.88	70.78	122.20	-51.42	Peak	
3	5860.0000	42.19	18.91	61.10	109.40	-48.30	Peak	

Orthogonal Axis:	X
Test Mode:	UNII-3/TX AC20 Mode 5825MHz

Horizontal

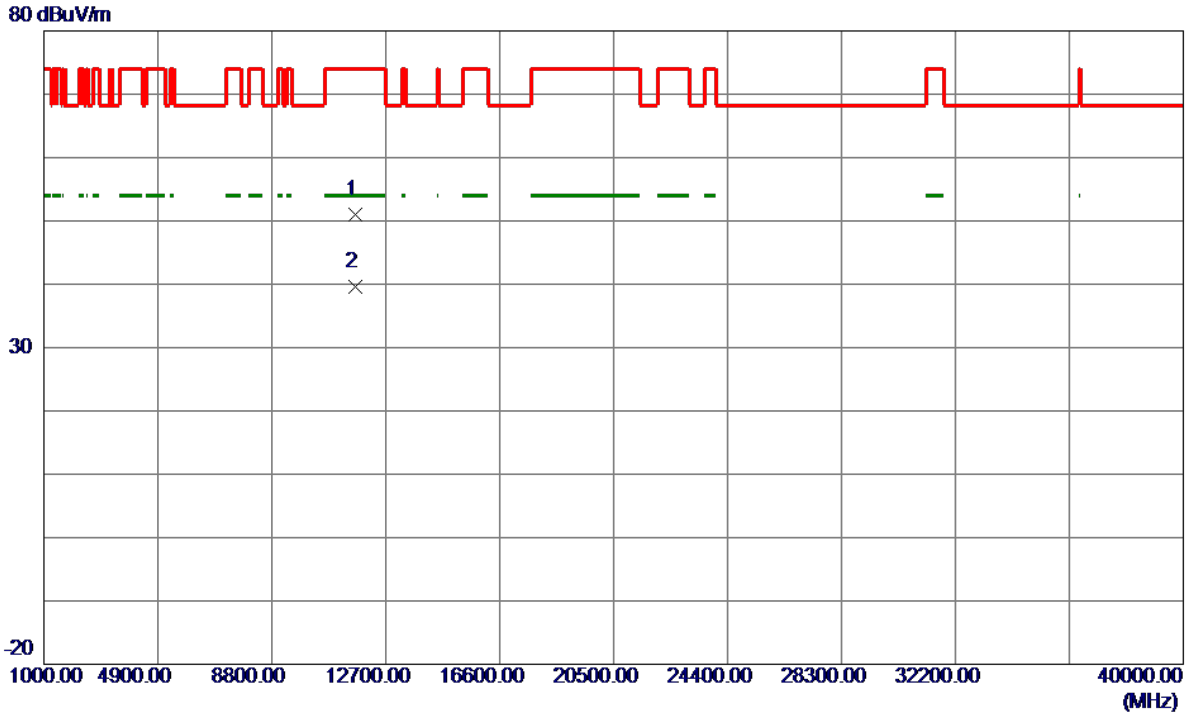

No.	Freq. MHz	Reading Level dBuV/m	Correct Factor dB	Measure ment dBuV/m	Limit dBuV/m	Margin dB	Detector	Comment
1	11648.8000	34.88	16.03	50.91	74.00	-23.09	Peak	
2 *	11649.3000	23.52	16.03	39.55	54.00	-14.45	AVG	

Orthogonal Axis:	X
Test Mode:	UNII-3/TX AC40 Mode 5755MHz

Vertical

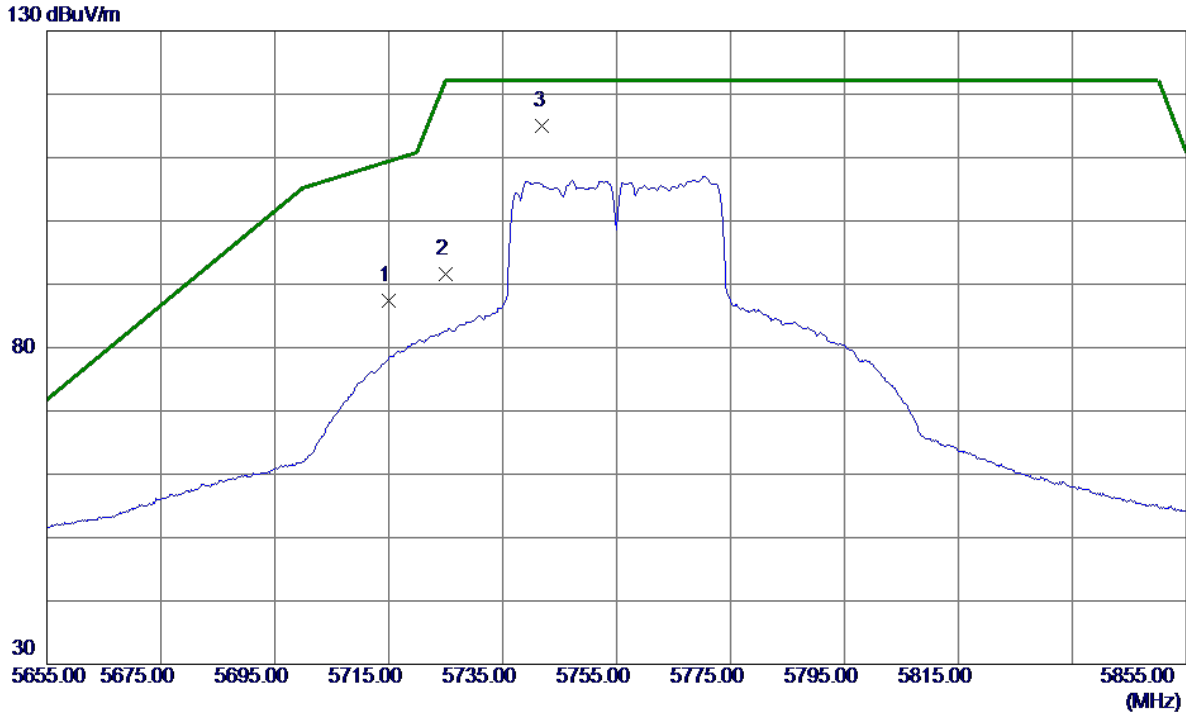

No.	Freq. MHz	Reading Level dBuV/m	Correct Factor dB	Measure ment dBuV/m	Limit dBuV/m	Margin dB	Detector	Comment
1	5715.0000	69.02	18.40	87.42	109.40	-21.98	Peak	
2	5725.0000	73.07	18.44	91.51	122.20	-30.69	Peak	
3 *	5742.0000	96.56	18.50	115.06	122.20	-7.14	Peak	

Orthogonal Axis:	X
Test Mode:	UNII-3/TX AC40 Mode 5755MHz

Vertical

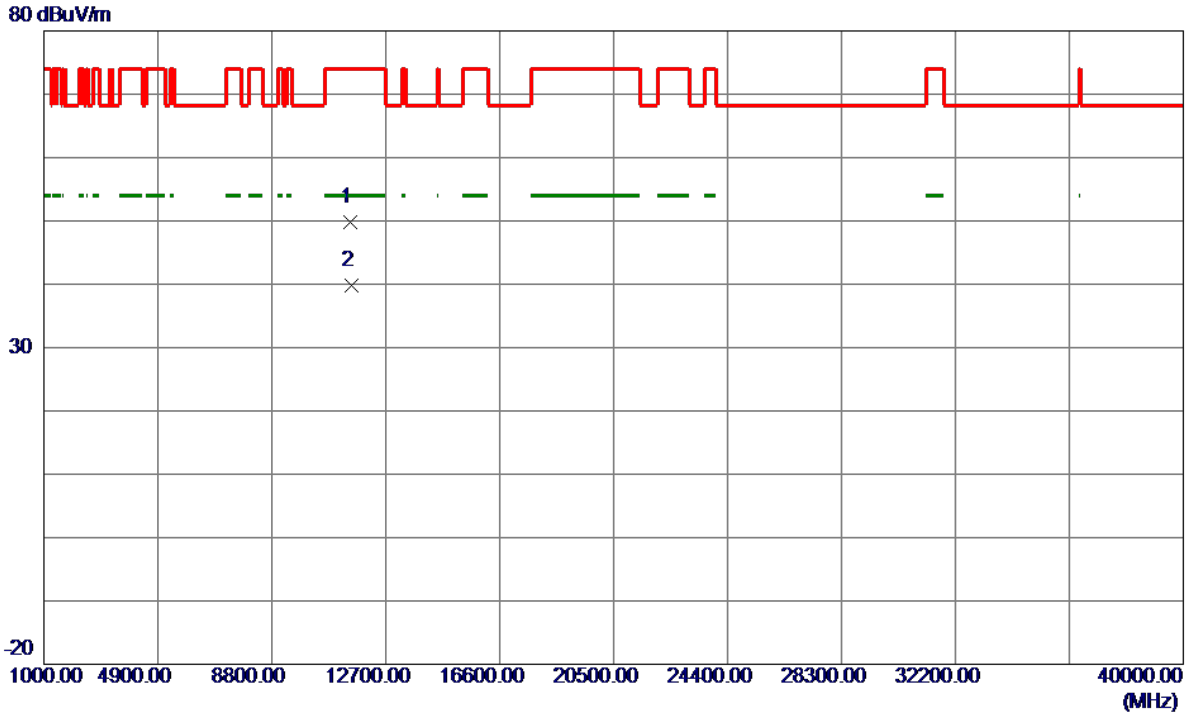

No.	Freq. MHz	Reading Level dBuV/m	Correct Factor dB	Measure ment dBuV/m	Limit dBuV/m	Margin dB	Detector	Comment
1	11507.9000	33.88	15.96	49.84	74.00	-24.16	Peak	
2 *	11510.5000	23.88	15.96	39.84	54.00	-14.16	AVG	

Orthogonal Axis:	X
Test Mode:	UNII-3/TX AC40 Mode 5755MHz

Horizontal

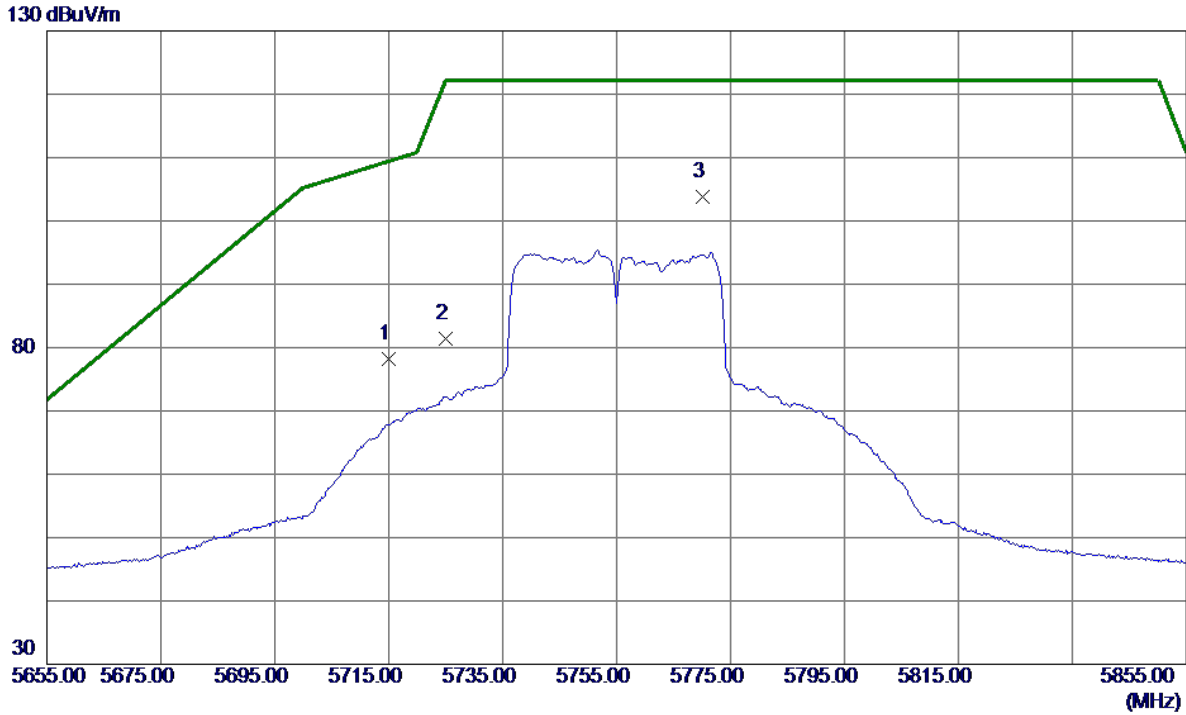

No.	Freq. MHz	Reading Level dBuV/m	Correct Factor dB	Measure ment dBuV/m	Limit dBuV/m	Margin dB	Detector	Comment
1	5715.0000	59.73	18.40	78.13	109.40	-31.27	Peak	
2	5725.0000	62.95	18.44	81.39	122.20	-40.81	Peak	
3 *	5770.2000	85.18	18.60	103.78	122.20	-18.42	Peak	

Orthogonal Axis:	X
Test Mode:	UNII-3/TX AC40 Mode 5755MHz

Horizontal

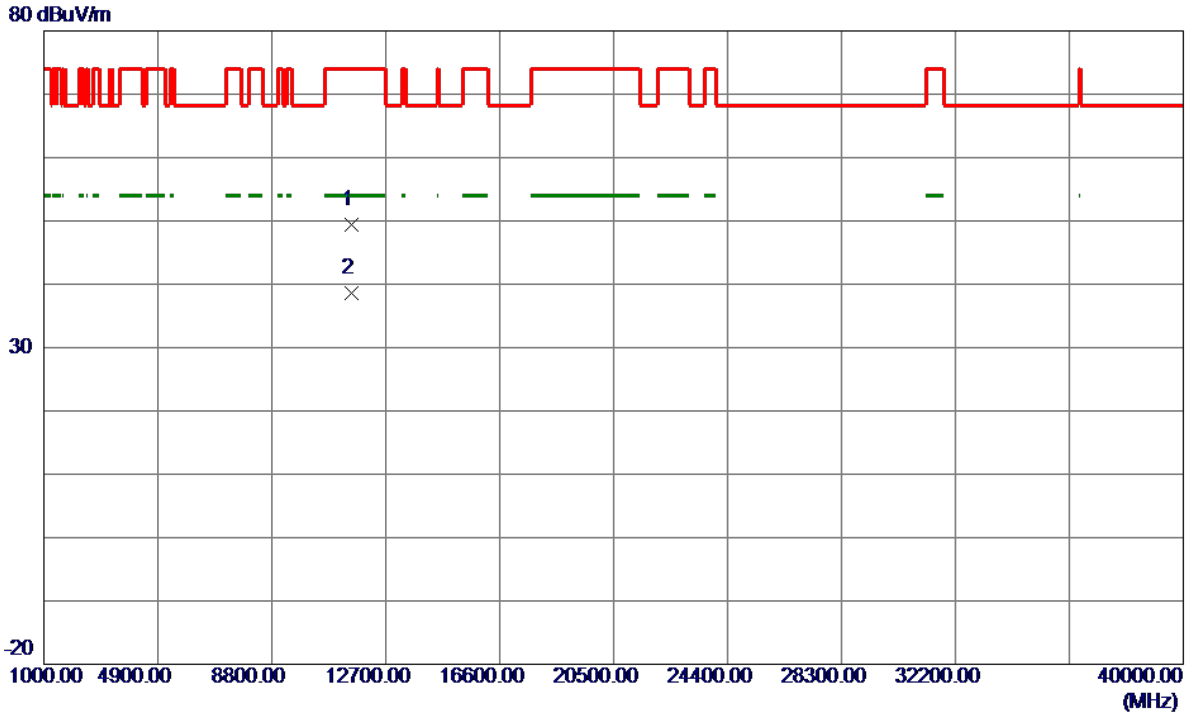

No.	Freq. MHz	Reading Level dBuV/m	Correct Factor dB	Measure ment dBuV/m	Limit dBuV/m	Margin dB	Detector	Comment
1	11511.9000	33.41	15.96	49.37	74.00	-24.63	Peak	
2 *	11512.6500	22.72	15.96	38.68	54.00	-15.32	AVG	

Orthogonal Axis:	X
Test Mode:	UNII-3/TX AC40 Mode 5795MHz

Vertical

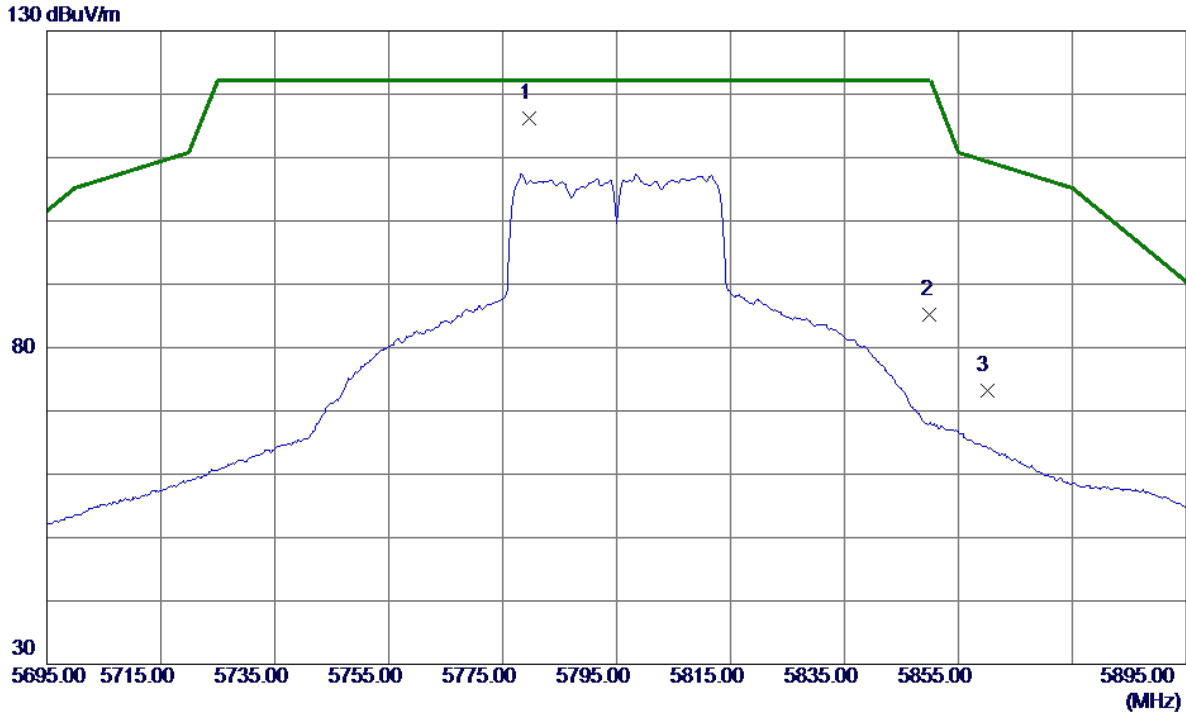

No.	Freq. MHz	Reading Level dBuV/m	Correct Factor dB	Measure ment dBuV/m	Limit dBuV/m	Margin dB	Detector	Comment
1 *	5779.6000	97.64	18.63	116.27	122.20	-5.93	Peak	
2	5850.0000	66.30	18.88	85.18	122.20	-37.02	Peak	
3	5860.0000	54.20	18.91	73.11	109.40	-36.29	Peak	

Orthogonal Axis:	X
Test Mode:	UNII-3/TX AC40 Mode 5795MHz

Vertical

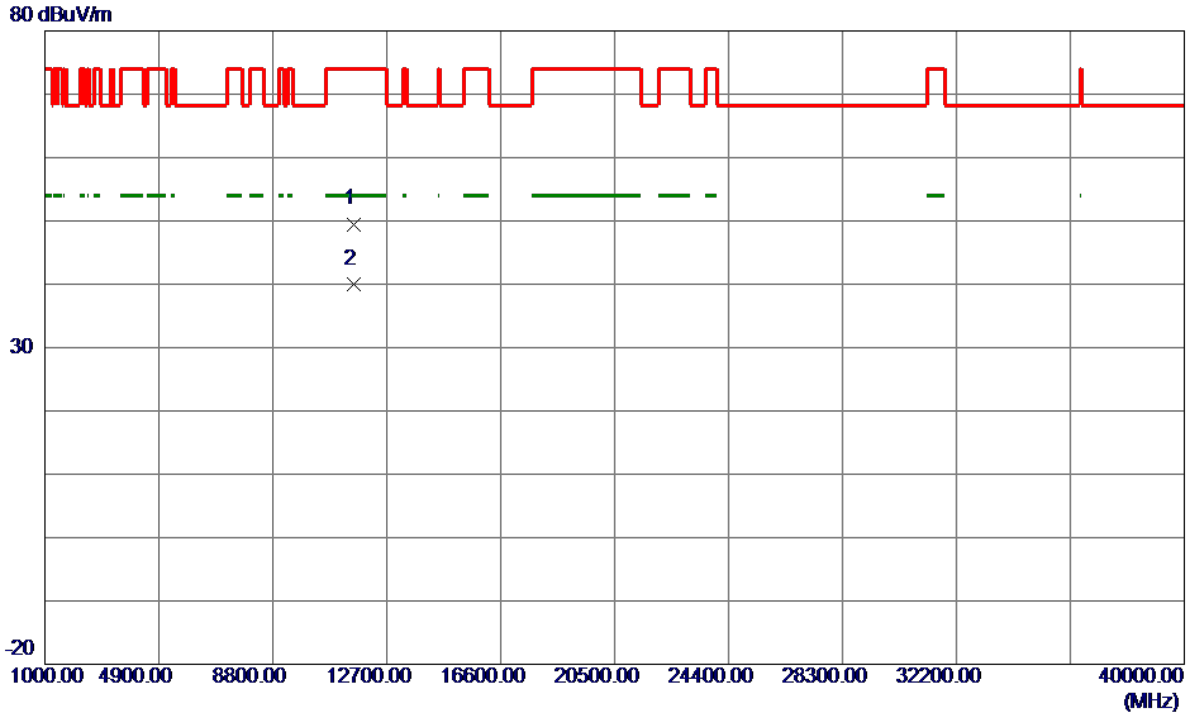

No.	Freq. MHz	Reading Level dBuV/m	Correct Factor dB	Measure ment dBuV/m	Limit dBuV/m	Margin dB	Detector	Comment
1	11577.5500	33.50	16.00	49.50	74.00	-24.50	Peak	
2 *	11588.0000	24.01	16.00	40.01	54.00	-13.99	AVG	

Orthogonal Axis:	X
Test Mode:	UNII-3/TX AC40 Mode 5795MHz

Horizontal

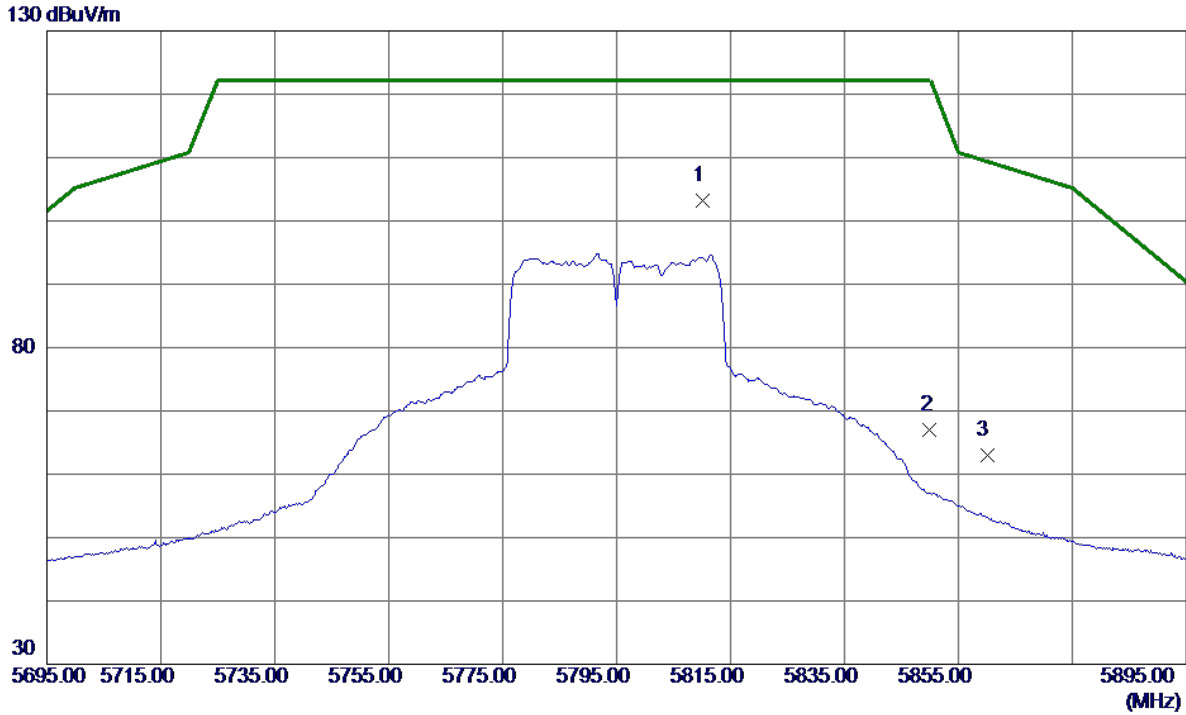

No.	Freq. MHz	Reading Level dBuV/m	Correct Factor dB	Measure ment dBuV/m	Limit dBuV/m	Margin dB	Detector	Comment
1 *	5810.2000	84.46	18.74	103.20	122.20	-19.00	Peak	
2	5850.0000	48.21	18.88	67.09	122.20	-55.11	Peak	
3	5860.0000	44.16	18.91	63.07	109.40	-46.33	Peak	

Orthogonal Axis:	X
Test Mode:	UNII-3/TX AC40 Mode 5795MHz

Horizontal

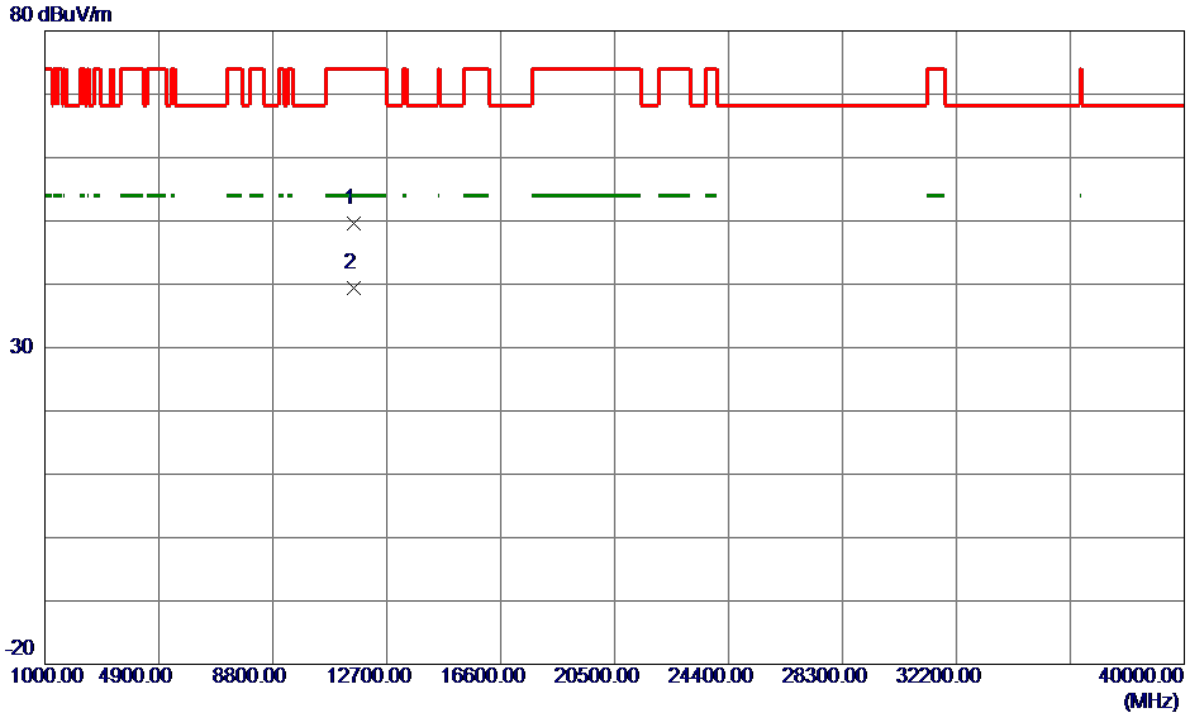

No.	Freq. MHz	Reading Level dBuV/m	Correct Factor dB	Measure ment dBuV/m	Limit dBuV/m	Margin dB	Detector	Comment
1	11582.1000	33.51	16.00	49.51	74.00	-24.49	Peak	
2 *	11590.1500	23.32	16.00	39.32	54.00	-14.68	AVG	

Orthogonal Axis:	X
Test Mode:	UNII-3/TX AC80 Mode 5775MHz

Vertical

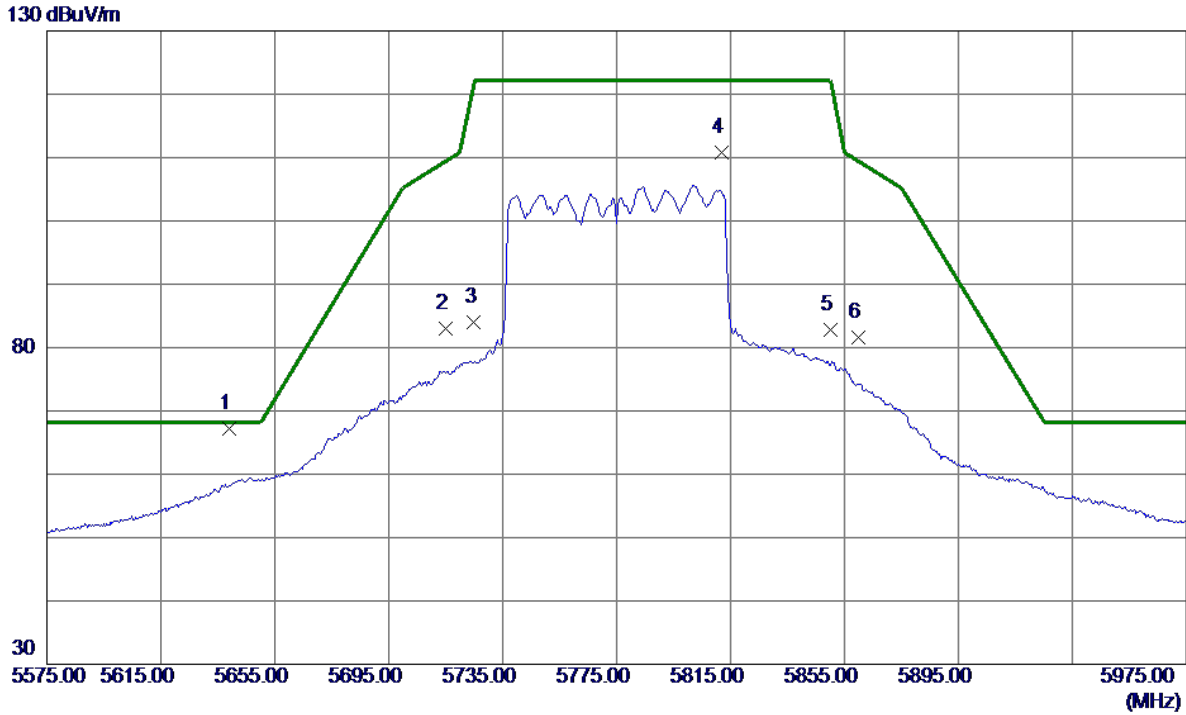

No.	Freq. MHz	Reading Level dBuV/m	Correct Factor dB	Measure ment dBuV/m	Limit dBuV/m	Margin dB	Detector	Comment
1 *	5639.0000	49.15	18.13	67.28	68.20	-0.92	Peak	
2	5715.0000	64.62	18.40	83.02	109.40	-26.38	Peak	
3	5725.0000	65.55	18.44	83.99	122.20	-38.21	Peak	
4	5811.8000	92.13	18.74	110.87	122.20	-11.33	Peak	
5	5850.0000	63.86	18.88	82.74	122.20	-39.46	Peak	
6	5860.0000	62.60	18.91	81.51	109.40	-27.89	Peak	

Orthogonal Axis:	X
Test Mode:	UNII-3/TX AC80 Mode 5775MHz

Vertical

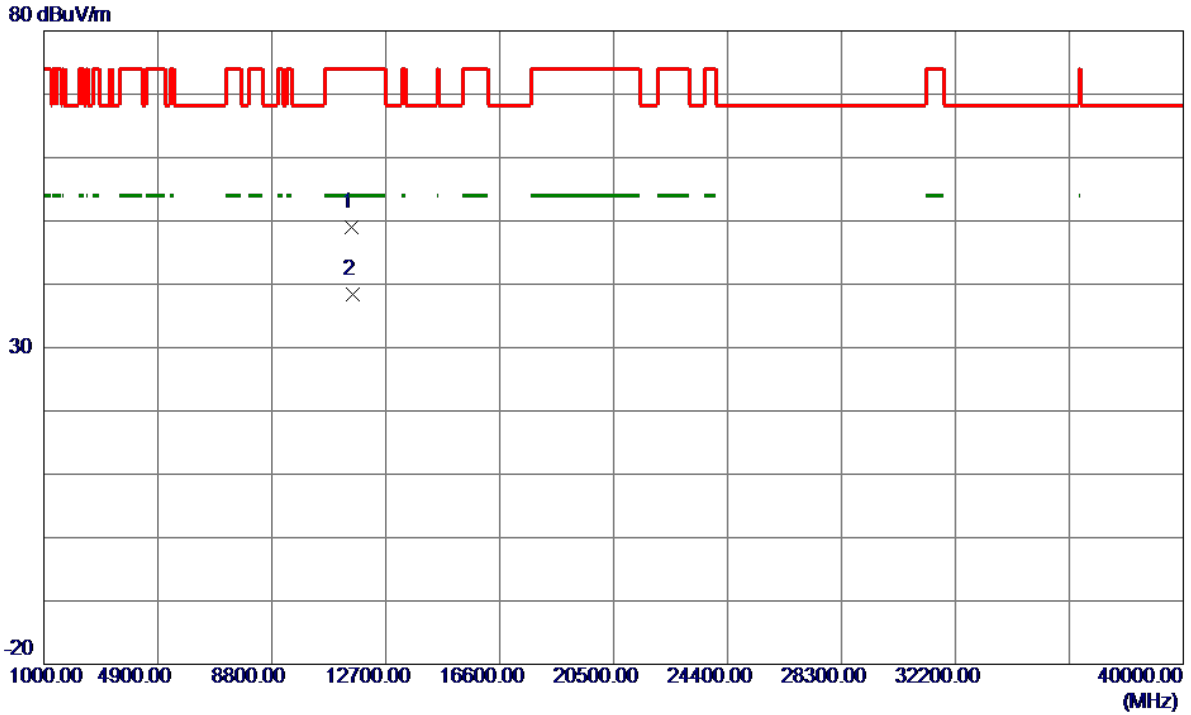

No.	Freq. MHz	Reading Level dBuV/m	Correct Factor dB	Measure ment dBuV/m	Limit dBuV/m	Margin dB	Detector	Comment
1	11527.1000	32.99	15.97	48.96	74.00	-25.04	Peak	
2 *	11559.6000	22.48	15.99	38.47	54.00	-15.53	AVG	

Orthogonal Axis:	X
Test Mode:	UNII-3/TX AC80 Mode 5775MHz

Horizontal

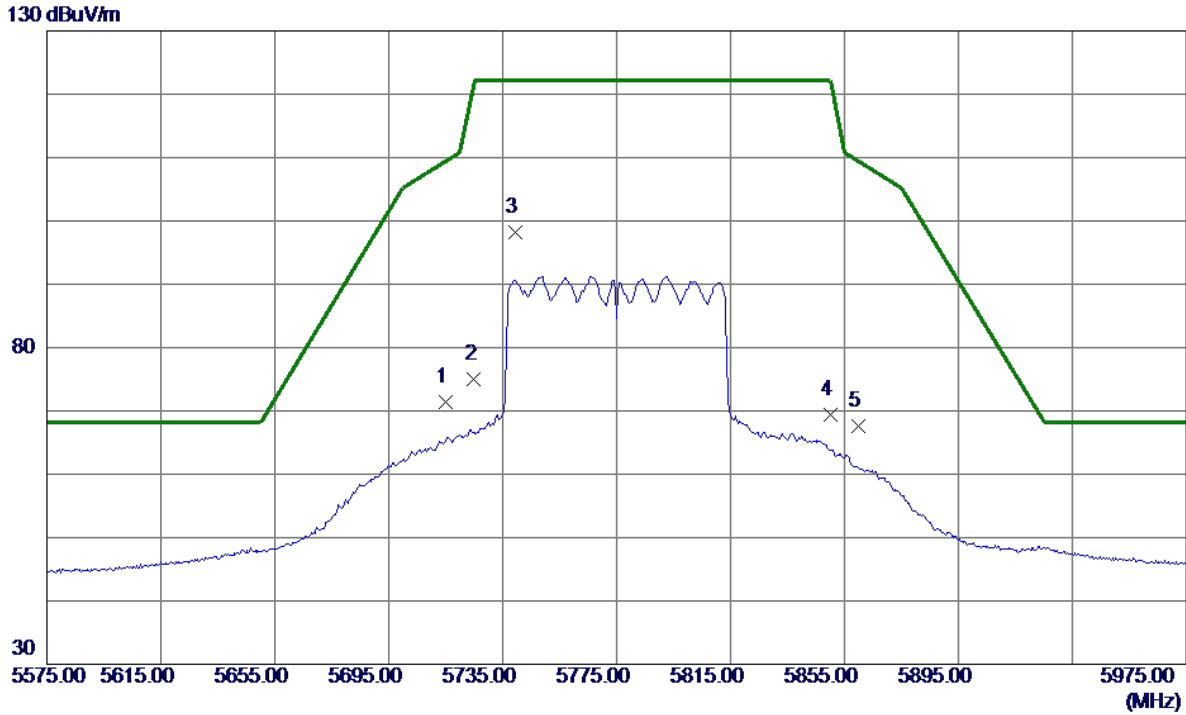

No.	Freq. MHz	Reading Level dBuV/m	Correct Factor dB	Measure ment dBuV/m	Limit dBuV/m	Margin dB	Detector	Comment
1	5715.0000	53.00	18.40	71.40	109.40	-38.00	Peak	
2	5725.0000	56.55	18.44	74.99	122.20	-47.21	Peak	
3 *	5739.4000	79.71	18.49	98.20	122.20	-24.00	Peak	
4	5850.0000	50.53	18.88	69.41	122.20	-52.79	Peak	
5	5860.0000	48.73	18.91	67.64	109.40	-41.76	Peak	

Orthogonal Axis:	X
Test Mode:	UNII-3/TX AC80 Mode 5775MHz

Horizontal

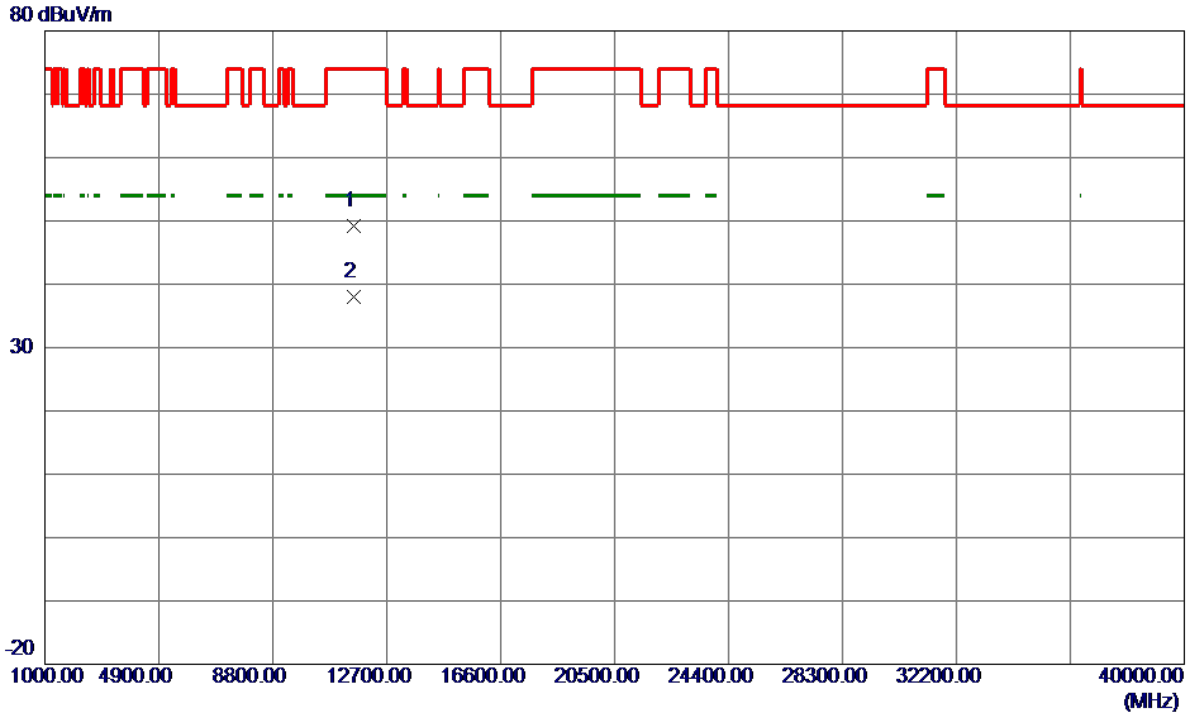

No.	Freq. MHz	Reading Level dBuV/m	Correct Factor dB	Measure ment dBuV/m	Limit dBuV/m	Margin dB	Detector	Comment
1	11558.0500	33.13	15.99	49.12	74.00	-24.88	Peak	
2 *	11566.3000	22.08	15.99	38.07	54.00	-15.93	AVG	

TX A Mode_DUTY CYCLE

Duty cycle: TX DUTYMHz

Duty cycle = T_{ON} / T_{Total}

T_{ON} : 100000.000 msec

T_{Total} : 100000.000 msec

Duty cycle: 100.000%

Duty Factor = $10 \log(1/Duty \text{ cycle})$

Duty Factor = 0.00

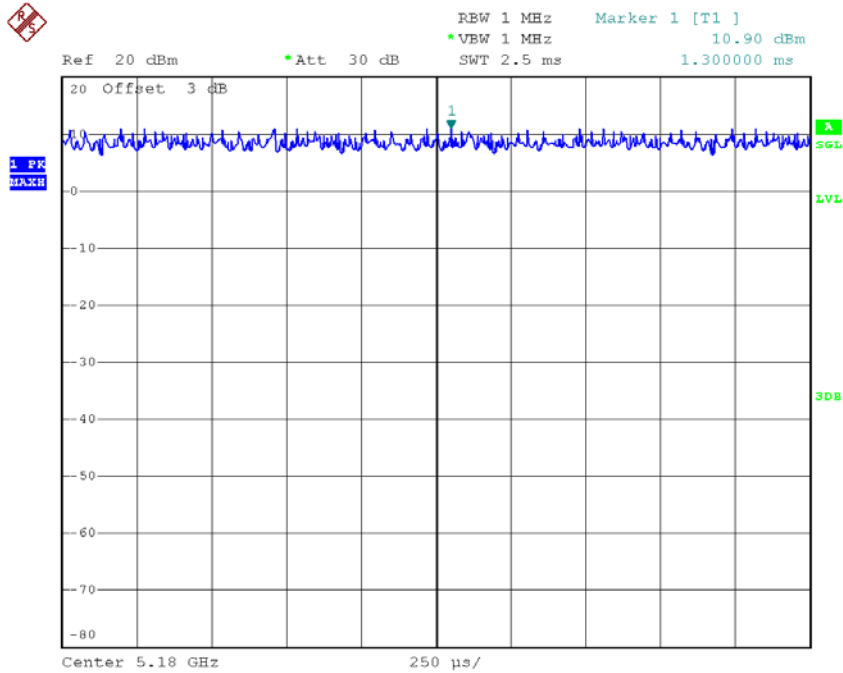

Date: 13.APR.2018 17:00:27

Note: The EUT was programmed to be in countinously transmitting mode and the transmit duty cycle is not less than 98 %, so, the output power and power density should be cacluated as Output Power = Measured power + Ducus factor
 Power Spectral Density = Measured density + Duty factor

TX N20 Mode_DUTY CYCLE

Duty cycle: TX DUTYMHz

Duty cycle = T_{ON} / T_{Total}

T_{ON} : 100000.000 msec

T_{Total} : 100000.000 msec

Duty cycle: 100.000%

Duty Factor = $10 \log(1/Duty \text{ cycle})$

Duty Factor = 0.00

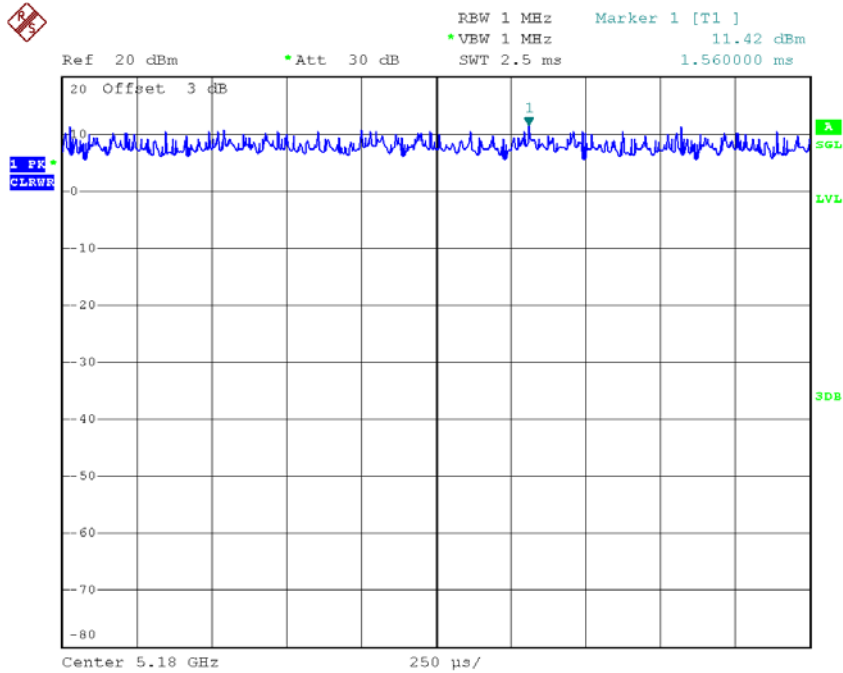

Date: 13.APR.2018 17:01:11

Note: The EUT was programmed to be in continuously transmitting mode and the transmit duty cycle is not less than 98 %, so, the output power and power density should be calculated as Output Power = Measured power + Duty factor
 Power Spectral Density = Measured density + Duty factor

TX N40 Mode_DUTY CYCLE

Duty cycle: TX DUTYMHZ

$$\text{Duty cycle} = T_{\text{ON}} / T_{\text{Total}}$$

T_{ON} : 100000.000 msec

T_{Total} : 100000.000 msec

Duty cycle: 100.000%

$$\text{Duty Factor} = 10 \log(1/\text{Duty cycle})$$

Duty Factor = 0.00

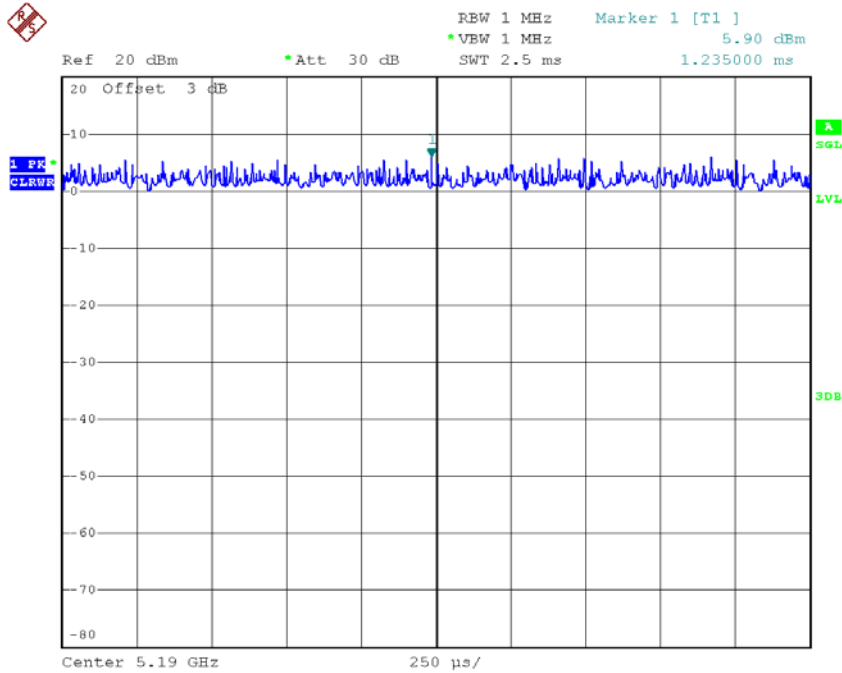

Date: 13.APR.2018 17:01:56

Note: The EUT was programmed to be in countinously transmitting mode and the transmit duty cycle is not less than 98 %, so, the output power and power density should be cacluated as Output Power = Measured power + Ducus factor
 Power Spectral Density = Measured density + Duty factor

TX AC20 Mode_DUTY CYCLE

Duty cycle: TX DUTYMHZ

Duty cycle = T_{ON} / T_{Total}

T_{ON} : 100000.000 msec

T_{Total} : 100000.000 msec

Duty cycle: 100.000%

Duty Factor = $10 \log(1/Duty \text{ cycle})$

Duty Factor = 0.00

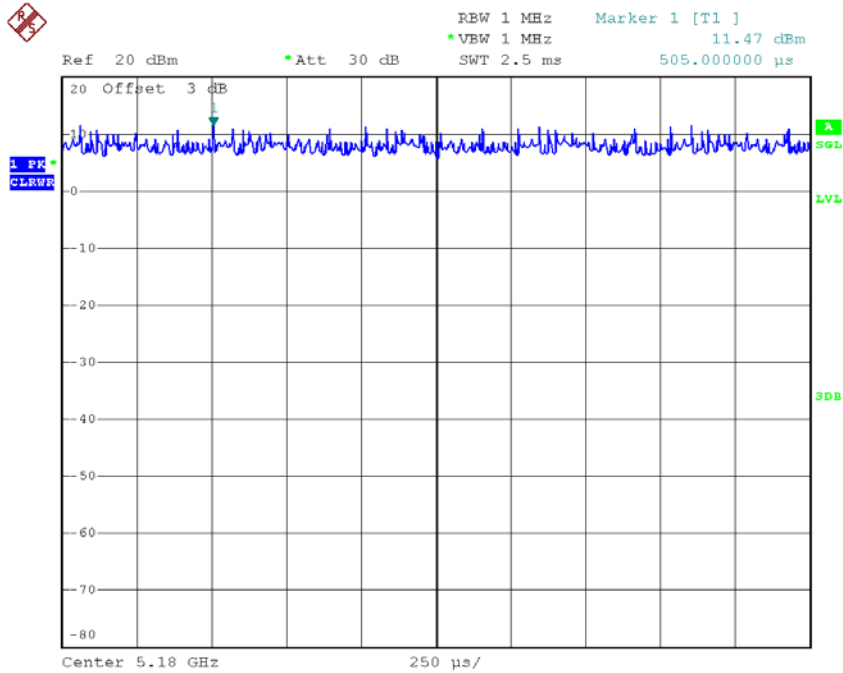

Date: 13.APR.2018 17:01:39

Note: The EUT was programmed to be in continuously transmitting mode and the transmit duty cycle is not less than 98 %, so, the output power and power density should be cacluated as Output Power = Measured power + Ducy factor
 Power Spectral Density = Measured density + Duty factor

TX AC40 Mode_DUTY CYCLE

Duty cycle: TX DUTYMHZ

Duty cycle = T_{ON} / T_{Total}

T_{ON} : 100000.000 msec

T_{Total} : 100000.000 msec

Duty cycle: 100.000%

Duty Factor = $10 \log(1/Duty \text{ cycle})$

Duty Factor = 0.00

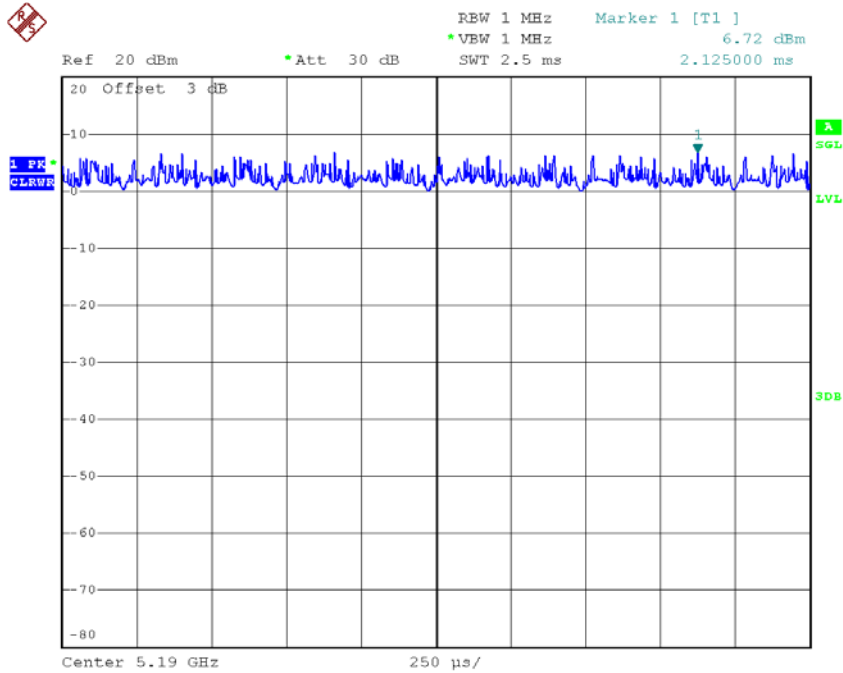

Date: 13.APR.2018 17:02:20

Note: The EUT was programmed to be in countinously transmitting mode and the transmit duty cycle is not less than 98 %, so, the output power and power density should be cacluated as Output Power = Measured power + Ducus factor
 Power Spectral Density = Measured density + Duty factor

TX AC80 Mode_DUTY CYCLE

Duty cycle: TX DUTYMHZ

Duty cycle = T_{ON} / T_{Total}

T_{ON} : 100000.000 msec

T_{Total} : 100000.000 msec

Duty cycle: 100.000%

Duty Factor = $10 \log(1/Duty \text{ cycle})$

Duty Factor = 0.00

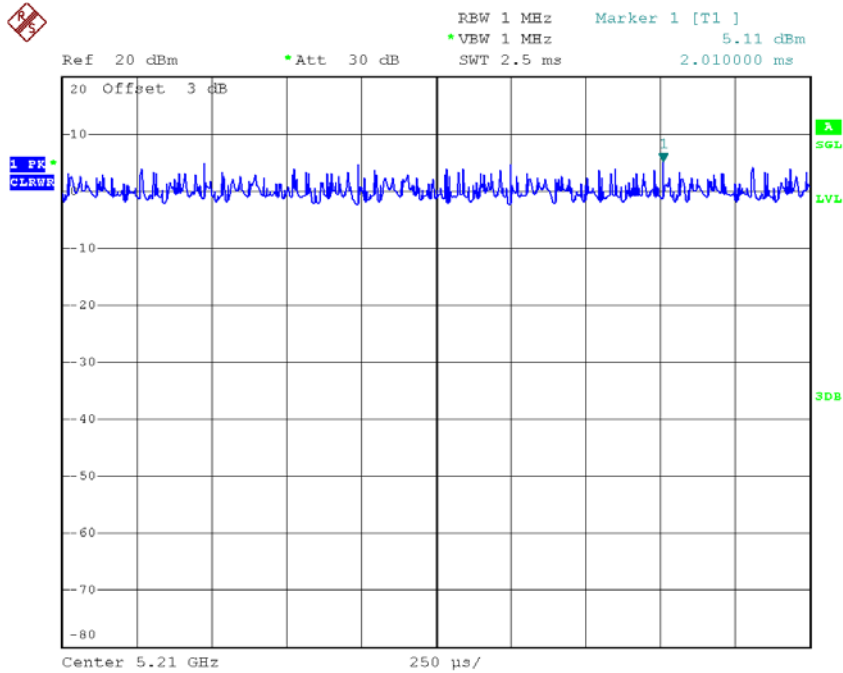

Date: 13.APR.2018 17:02:39

Note: The EUT was programmed to be in countinously transmitting mode and the transmit duty cycle is not less than 98 %, so, the output power and power density should be cacluated as Output Power = Measured power + Ducus factor
Power Spectral Density = Measured density + Duty factor

APPENDIX E - BANDWIDTH