

FCC Radio Test Report

FCC ID: V7TAC9

This report concerns (check one): Original Grant Class II Change

Project No. : 1603C223
Equipment : AC1200 Smart Dual-Band Gigabit WiFi Router
Model Name : AC9
Applicant : SHENZHEN TENDA TECHNOLOGY CO.,LTD
Address : 6-8 Floor, Tower E3, No. 1001, Zhongshanyuan Road, Nanshan District, Shenzhen, China. 518052

Date of Receipt : Mar. 17, 2016
Date of Test : Mar. 17, 2016 ~ Jun. 08, 2016
Issued Date : Jun. 13, 2016
Tested by : BTL Inc.

Testing Engineer : Shawn Xiao
(Shawn Xiao)

Technical Manager : David Mao
(David Mao)

Authorized Signatory : Steven Lu
(Steven Lu)

B T L I N C .

No.3, Jinshagang 1st Road, Shixia, Dalang Town, Dongguan,
Guangdong, China.

TEL: +86-769-8318-3000 FAX: +86-769-8319-6000

Declaration

BTL represents to the client that testing is done in accordance with standard procedures as applicable and that test instruments used has been calibrated with standards traceable to international standard(s) and/or national standard(s).

BTL's reports apply only to the specific samples tested under conditions. It is manufacture's responsibility to ensure that additional production units of this model are manufactured with the identical electrical and mechanical components. **BTL** shall have no liability for any declarations, inferences or generalizations drawn by the client or others from **BTL** issued reports.

BTL's report must not be used by the client to claim product certification, approval, or endorsement by NVLAP, NIST, or any agency of the Federal Government.

This report is the confidential property of the client. As a mutual protection to the clients, the public and **BTL-self**, extracts from the test report shall not be reproduced except in full with **BTL's** authorized written approval.

BTL's laboratory quality assurance procedures are in compliance with the **ISO Guide 17025** requirements, and accredited by the conformity assessment authorities listed in this test report.

Limitation

For the use of the authority's logo is limited unless the Test Standard(s)/Scope(s)/Item(s) mentioned in this test report is (are) included in the conformity assessment authorities acceptance respective.

Table of Contents	Page
1 . CERTIFICATION	6
2 . SUMMARY OF TEST RESULTS	7
2.1 TEST FACILITY	8
2.2 MEASUREMENT UNCERTAINTY	8
3 . GENERAL INFORMATION	9
3.1 GENERAL DESCRIPTION OF EUT	9
3.2 DESCRIPTION OF TEST MODES	11
3.3 TABLE OF PARAMETERS OF TEST SOFTWARE SETTING	12
3.4 BLOCK DIAGRAM SHOWING THE CONFIGURATION OF SYSTEM TESTED	14
3.5 DESCRIPTION OF SUPPORT UNITS	14
4 . EMC EMISSION TEST	15
4.1 CONDUCTED EMISSION MEASUREMENT	15
4.1.1 POWER LINE CONDUCTED EMISSION	15
4.1.2 TEST PROCEDURE	15
4.1.3 DEVIATION FROM TEST STANDARD	15
4.1.4 TEST SETUP	16
4.1.5 EUT OPERATING CONDITIONS	16
4.1.6 EUT TEST CONDITIONS	16
4.1.7 TEST RESULTS	16
4.2 RADIATED EMISSION MEASUREMENT	17
4.2.1 RADIATED EMISSION LIMITS	17
4.2.2 TEST PROCEDURE	18
4.2.3 DEVIATION FROM TEST STANDARD	18
4.2.4 TEST SETUP	18
4.2.5 EUT OPERATING CONDITIONS	19
4.2.6 EUT TEST CONDITIONS	19
4.2.7 TEST RESULTS (9K TO 30MHz)	20
4.2.8 TEST RESULTS (BETWEEN 30 TO 1000 MHz)	20
4.2.9 TEST RESULTS (ABOVE 1000 MHz)	20
5 . 26dB SPECTRUM BANDWIDTH	21
5.1 APPLIED PROCEDURES / LIMIT	21
5.1.1 TEST PROCEDURE	21
5.1.2 DEVIATION FROM STANDARD	21
5.1.3 TEST SETUP	21
5.1.4 EUT OPERATION CONDITIONS	21
5.1.5 EUT TEST CONDITIONS	22
5.1.6 TEST RESULTS	22
6 . MAXIMUM CONDUCTED OUTPUT POWER	23

Table of Contents	Page
6.1 APPLIED PROCEDURES / LIMIT	23
6.1.1 TEST PROCEDURE	23
6.1.2 DEVIATION FROM STANDARD	24
6.1.3 TEST SETUP	24
6.1.4 EUT OPERATION CONDITIONS	24
6.1.5 EUT TEST CONDITIONS	24
6.1.6 TEST RESULTS	24
7 . POWER SPECTRAL DENSITY TEST	25
7.1 APPLIED PROCEDURES / LIMIT	25
8.1.1 TEST PROCEDURE	25
7.1.1 DEVIATION FROM STANDARD	26
7.1.2 TEST SETUP	26
7.1.3 EUT OPERATION CONDITIONS	26
7.1.4 EUT TEST CONDITIONS	26
7.1.5 TEST RESULTS	26
8 . FREQUENCY STABILITY MEASUREMENT	27
8.1 APPLIED PROCEDURES / LIMIT	27
8.1.1 TEST PROCEDURE	27
8.1.2 DEVIATION FROM STANDARD	27
8.1.3 TEST SETUP	28
8.1.4 EUT OPERATION CONDITIONS	28
8.1.5 EUT TEST CONDITIONS	28
8.1.6 TEST RESULTS	28
9 . MEASUREMENT INSTRUMENTS LIST	29
10 . EUT TEST PHOTOS	31
ATTACHMENT A - CONDUCTED EMISSION	35
ATTACHMENT B - RADIATED EMISSION (9KHZ TO 30MHZ)	38
ATTACHMENT C - RADIATED EMISSION (30MHZ TO 1000MHZ)	40
ATTACHMENT D - RADIATED EMISSION (ABOVE 1000MHZ)	53
ATTACHMENT E - BANDWIDTH	172
ATTACHMENT F - MAXIMUM OUTPUT POWER	195
ATTACHMENT G - POWER SPECTRAL DENSITY	206
ATTACHMENT H - FREQUENCY STABILITY	257

REPORT ISSUED HISTORY

Issued No.	Description	Issued Date
BTL-FCCP-2-1603C223	Original Issue.	Jun. 13, 2016

1. CERTIFICATION

Equipment : AC1200 Smart Dual-Band Gigabit WiFi Router
Brand Name : Tenda
Model Name : AC9
Applicant : SHENZHEN TENDA TECHNOLOGY CO.,LTD.
Manufacturer : SHENZHEN TENDA TECHNOLOGY CO.,LTD.
Address : 6-8 Floor, Tower E3, No. 1001, Zhongshanyuan Road, Nanshan District,
Shenzhen, China. 518052
Date of Test : Mar. 17, 2016 ~ Jun. 08, 2016
Test Sample : Engineering Sample
Standard(s) : FCC Part15, Subpart E(15.407) / ANSI C63.10-2013

The above equipment has been tested and found compliance with the requirement of the relative standards by BTL Inc.

The test data, data evaluation, and equipment configuration contained in our test report (Ref No. BTL-FCCP-2-1603C223) were obtained utilizing the test procedures, test instruments, test sites that has been accredited by the Authority of TAF according to the ISO-17025 quality assessment standard and technical standard(s).

2. SUMMARY OF TEST RESULTS

Test procedures according to the technical standard(s):

FCC Part15, Subpart E			
Standard(s) Section	Test Item	Judgment	Remark
15.207	AC Power Line Conducted Emissions	PASS	
15.407(a)	26dB Spectrum Bandwidth	PASS	
15.407(a)	Maximum Conducted Output Power	PASS	
15.407(a)	Power Spectral Density	PASS	
15.407(a)	Radiated Emissions	PASS	
15.407(b)	Band Edge Emissions	PASS	
15.407(g)	Frequency Stability	PASS	
15.203	Antenna Requirements	PASS	

NOTE:

(1) "N/A" denotes test is not applicable in this test report.

2.1 TEST FACILITY

The test facilities used to collect the test data in this report is at the location of No.3,Jinshagang 1st Road, Shixia, Dalang Town, Dongguan, Guangdong, China.
BTL's test firm number for FCC: 319330

2.2 MEASUREMENT UNCERTAINTY

Where relevant, the following measurement uncertainty levels have been estimated for tests performed on the EUT as specified in CISPR 16-4-2. The BTL measurement uncertainty is less than the CISPR 16-4-2 U_{CISPR} requirement.

The reported uncertainty of measurement $y \pm U$, where expanded uncertainty U is based on a standard uncertainty multiplied by a coverage factor of $k=2$, providing a level of confidence of approximately 95 %.

A. Conducted Measurement:

Test Site	Method	Measurement Frequency Range	U, (dB)
DG-C02	CISPR	150 KHz ~ 30MHz	1.94

B. Radiated Measurement:

Test Site	Method	Measurement Frequency Range	Ant. H / V	U, (dB)
DG-CB03	CISPR	9kHz~30MHz	V	3.79
		9kHz~30MHz	H	3.57
		30MHz ~ 200MHz	V	3.82
		30MHz ~ 200MHz	H	3.60
		200MHz ~ 1,000MHz	V	3.86
		200MHz ~ 1,000MHz	H	3.94
		1GHz~18GHz	V	3.12
		1GHz~18GHz	H	3.68
		18GHz~40GHz	V	4.15
		18GHz~40GHz	H	4.14

Note: Unless specifically mentioned, the uncertainty of measurement has not been taken into account to declare the compliance or non-compliance to the specification.

3. GENERAL INFORMATION

3.1 GENERAL DESCRIPTION OF EUT

Equipment	AC1200 Smart Dual-Band Gigabit WiFi Router	
Brand Name	Tenda	
Model Name	AC9	
Mode Different	N/A	
Product Description	Operation Frequency	UNII-1: 5150-5250MHz UNII-3: 5725-5850MHz
	Modulation Type	OFDM
	Bit Rate of Transmitter	866Mbps
Output Power	Output Power (Max.)for UNII-1	802.11A: 18.99dBm 802.11N (20M): 19.77dBm 802.11N (40M): 19.59dBm 802.11AC (VHT20MHz): 19.45dBm 802.11AC (VHT40MHz): 19.95dBm 802.11AC (VHT80MHz): 19.89dBm
	Output Power (Max.)for UNII-3	802.11A: 13.89dBm 802.11N (20M): 16.05dBm 802.11N (40M): 18.24dBm 802.11AC (VHT20MHz): 15.28dBm 802.11AC (VHT40MHz): 17.83dBm 802.11AC (VHT80MHz): 19.85dBm
Power Source	DC Voltage supplied from AC/DC adapter. Manufacturer: SHENZHEN HEWEISHUN NETWORK TECHNOLOGY CO.,LTD Model: BN058-A24012U	
Power Rating	I/P: 100-240V ~, 50/60Hz, 0.7A O/P:12V 2.0A	

Note:

- For a more detailed features description, please refer to the manufacturer's specifications or the user's manual.
- Channel List:

UNII-1		UNII-1		UNII-1	
Channel	Frequency (MHz)	Channel	Frequency (MHz)	Channel	Frequency (MHz)
36	5180	38	5190	42	5210
40	5200	46	5230		
44	5220				
48	5240				

UNII-3		UNII-3		UNII-3	
Channel	Frequency (MHz)	Channel	Frequency (MHz)	Channel	Frequency (MHz)
149	5745	151	5755	155	5775
153	5765	159	5795		
157	5785				
161	5805				
165	5825				

3. Antenna Specification:

Ant.	Brand	Model Name	Antenna Type	Connector	Gain (dBi)
1	Tenda	N/A	Dipole	N/A	3
2	Tenda	N/A	Dipole	N/A	3

Note:

- (1) The EUT incorporates a MIMO function. Physically, the EUT provides two completed two transmitters and two receivers (2T2R).
- (2) ANT 1 for 1TX was found to be the worst case and recorded.

4.

Operating Mode TX Mode	1TX	2TX
802.11A	V (ANT 1)	-
802.11N (20MHz)	-	V (ANT 1+ANT 2)
802.11N (40MHz)	-	V (ANT 1+ANT 2)
802.11AC (VHT20MHz)	-	V (ANT 1+ANT 2)
802.11AC (VHT40MHz)	-	V (ANT 1+ANT 2)
802.11AC (VHT80MHz)	-	V (ANT 1+ANT 2)

3.2 DESCRIPTION OF TEST MODES

To investigate the maximum EMI emission characteristics generates from EUT, the test system was pre-scanning tested base on the consideration of following EUT operation mode or test configuration mode which possible have effect on EMI emission level. Each of these EUT operation mode(s) or test configuration mode(s) mentioned above was evaluated respectively.

Pretest Mode	Description
Mode 1	TX A Mode / CH36, CH40, CH48 (UNII-1)
Mode 2	TX N20 Mode / CH36, CH40, CH48 (UNII-1)
Mode 3	TX N40 Mode / CH38, CH46 (UNII-1)
Mode 4	TX AC (VHT20MHz) Mode / CH36, CH40, CH48 (UNII-1)
Mode 5	TX AC (VHT40MHz) Mode / CH38, CH46 (UNII-1)
Mode 6	TX AC(VHT80) Mode / CH42 (UNII-1)
Mode 7	TX A Mode / CH149,CH157,CH165 (UNII-3)
Mode 8	TX N20 Mode / CH149,CH157,CH165 (UNII-3)
Mode 9	TX N40 Mode / CH151,CH159 (UNII-3)
Mode 10	TX AC (VHT20MHz) Mode / CH149,CH157,CH165 (UNII-3)
Mode 11	TX AC (VHT40MHz) Mode / CH151,CH159 (UNII-3)
Mode 12	TX AC(VHT80) Mode / CH155 (UNII-3)
Mode 13	TX Mode

The EUT system operated these modes were found to be the worst case during the pre-scanning test as following:

For Conducted Test	
Final Test Mode	Description
Mode 13	TX Mode

For Radiated Test	
Final Test Mode	Description
Mode 1	TX A Mode / CH36, CH40, CH48 (UNII-1)
Mode 2	TX N20 Mode / CH36, CH40, CH48 (UNII-1)
Mode 3	TX N40 Mode / CH38, CH46 (UNII-1)
Mode 4	TX AC (VHT20MHz) Mode / CH36, CH40, CH48 (UNII-1)
Mode 5	TX AC (VHT40MHz) Mode / CH38, CH46 (UNII-1)
Mode 6	TX AC(VHT80) Mode / CH42 (UNII-1)
Mode 7	TX A Mode / CH149,CH157,CH165 (UNII-3)
Mode 8	TX N20 Mode / CH149,CH157,CH165 (UNII-3)
Mode 9	TX N40 Mode / CH151,CH159 (UNII-3)
Mode 10	TX AC (VHT20MHz) Mode / CH149,CH157,CH165 (UNII-3)
Mode 11	TX AC (VHT40MHz) Mode / CH151,CH159 (UNII-3)
Mode 12	TX AC(VHT80) Mode / CH155 (UNII-3)

Note:

(1) For radiated below 1GHz test, the 802.11A mode is found to be the worst case and recorded.

3.3 TABLE OF PARAMETERS OF TEST SOFTWARE SETTING

During testing channel & power controlling software provided by the customer was used to control the operating channel as well as the output power level. The RF output power selection is for the setting of RF output power expected by the customer and is going to be fixed on the firmware of the final end product

UNII-1 - 1TX			
Test Software Version	MTool_REL_2_0_1_7		
Frequency (MHz)	5180	5200	5240
A Mode	74	74	76

UNII-3 - 1TX			
Test Software Version	MTool_REL_2_0_1_7		
Frequency (MHz)	5745	5785	5825
A Mode	56	56	56

UNII-1 - 2TX			
Test Software Version	MTool_REL_2_0_1_7		
Frequency (MHz)	5180	5200	5240
N20 Mode	66	68	68
Frequency (MHz)	5190	5230	
N40 Mode	66	68	

UNII-3 - 2TX			
Test Software Version	MTool_REL_2_0_1_7		
Frequency (MHz)	5745	5785	5825
N20 Mode	52	52	52
Frequency (MHz)	5755	5795	
N40 Mode	61	60	

UNII-1 - 2TX			
Test Software Version	MTool_REL_2_0_1_7		
Frequency (MHz)	5180	5200	5240
AC (VHT20MHz) Mode	64	65	67
Frequency (MHz)	5190	5230	
AC (VHT40MHz) Mode	70	77	
Frequency (MHz)	5210		
AC(VHT80) Mode	67		

UNII-3 - 2TX			
Test Software Version	MTool_REL_2_0_1_7		
Frequency (MHz)	5745	5785	5825
AC (VHT20MHz) Mode	49	49	50
Frequency (MHz)	5755	5795	
AC (VHT40MHz) Mode	60	61	
Frequency (MHz)	5775		
AC(VHT80) Mode	67		

3.4 BLOCK DIAGRAM SHOWING THE CONFIGURATION OF SYSTEM TESTED

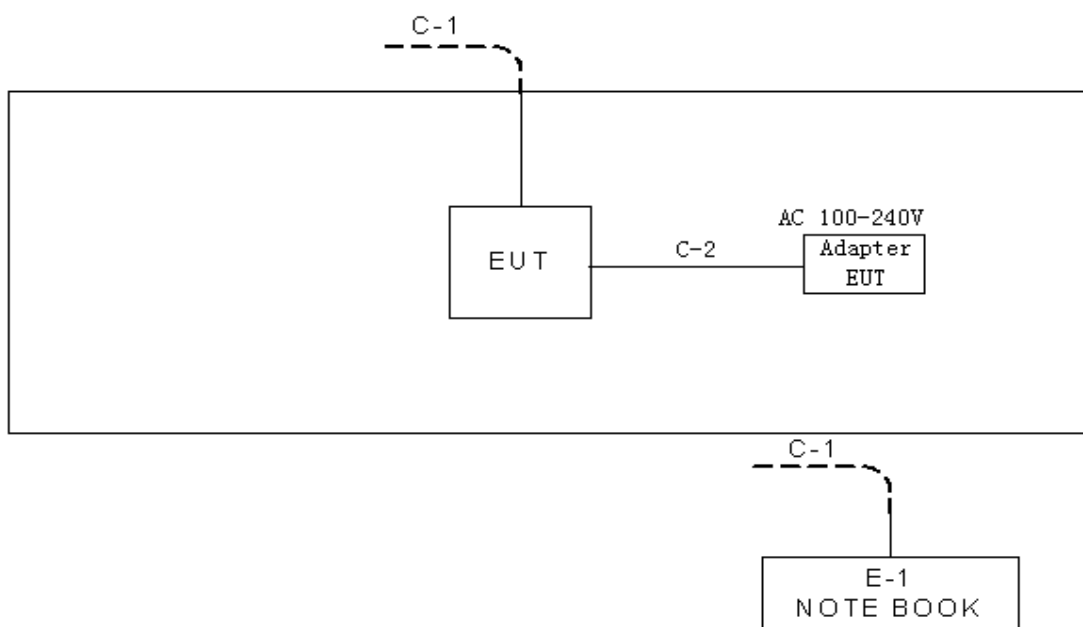

3.5 DESCRIPTION OF SUPPORT UNITS

The EUT has been tested as an independent unit together with other necessary accessories or support units. The following support units or accessories were used to form a representative test configuration during the tests.

Item	Equipment	Mfr/Brand	Model/Type No.	FCC ID	Series No.
E-1	Notebook	DELL	DCSM	DOC	G7K832X

Item	Shielded Type	Ferrite Core	Length	Note
C-1	NO	NO	10M	RJ-45 Cable
C-2	NO	NO	1M	DC Cable

4. EMC EMISSION TEST

4.1 CONDUCTED EMISSION MEASUREMENT

4.1.1 POWER LINE CONDUCTED EMISSION (Frequency Range 150kHz-30MHz)

FREQUENCY (MHz)	Class A (dBuV)		Class B (dBuV)	
	Quasi-peak	Average	Quasi-peak	Average
0.15 -0.5	79.00	66.00	66 - 56 *	56 - 46 *
0.50 -5.0	73.00	60.00	56.00	46.00
5.0 -30.0	73.00	60.00	60.00	50.00

Note:

- (1) The tighter limit applies at the band edges.
- (2) The limit of " * " marked band means the limitation decreases linearly with the logarithm of the frequency in the range.

4.1.2 TEST PROCEDURE

- a. The EUT was placed 0.8 meters from the horizontal ground plane with EUT being connected to the power mains through a line impedance stabilization network (LISN). All other support equipments powered from additional LISN(s). The LISN provide 50 Ohm/ 50uH of coupling impedance for the measuring instrument.
- b. Interconnecting cables that hang closer than 40 cm to the ground plane shall be folded back and forth in the center forming a bundle 30 to 40 cm long.
- c. I/O cables that are not connected to a peripheral shall be bundled in the center. The end of the cable may be terminated, if required, using the correct terminating impedance. The overall length shall not exceed 1 m.
- d. LISN at least 80 cm from nearest part of EUT chassis.
- e. For the actual test configuration, please refer to the related Item –EUT Test Photos.

4.1.3 DEVIATION FROM TEST STANDARD

No deviation

4.1.4 TEST SETUP

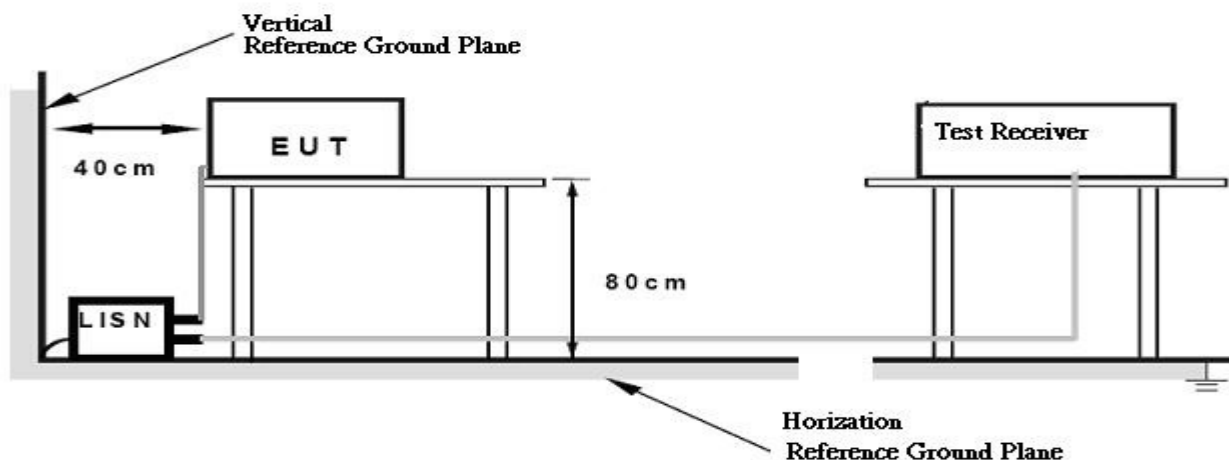

4.1.5 EUT OPERATING CONDITIONS

The EUT was configured for testing in a typical fashion (as a customer would normally use it). The EUT has been programmed to continuously transmit during test. This operating condition was tested and used to collect the included data.

The EUT was programmed to be in continuously transmitting/TX Mode mode.

4.1.6 EUT TEST CONDITIONS

Temperature: 24°C Relative Humidity: 60% Test Voltage: AC 120V/60Hz

4.1.7 TEST RESULTS

Please refer to the Attachment A.

Remark:

- (1) All readings are QP Mode value unless otherwise stated AVG in column of 『Note』. If the QP Mode Measured value compliance with the QP Limits and lower than AVG Limits, the EUT shall be deemed to meet both QP & AVG Limits and then only QP Mode was measured, but AVG Mode didn't perform. In this case, a “ * ” marked in AVG Mode column of Interference Voltage Measured.
- (2) Measuring frequency range from 150kHz to 30MHz.

4.2 RADIATED EMISSION MEASUREMENT

4.2.1 RADIATED EMISSION LIMITS

20dBc in any 100 kHz bandwidth outside the operating frequency band. In case the emission fall within the restricted band specified on 15.205(a), then the 15.209(a) limit in the table below has to be followed.

Frequencies (MHz)	Field Strength (micorvolts/meter)	Measurement Distance (meters)
0.009~0.490	2400/F(kHz)	300
0.490~1.705	24000/F(kHz)	30
1.705~30.0	30	30
30~88	100	3
88~216	150	3
216~960	200	3
Above 960	500	3

Note:

- (1) The limit for radiated test was performed according to FCC PART 15C.
- (2) The tighter limit applies at the band edges.

LIMITS OF UNWANTED EMISSION OUT OF THE RESTRICTED BANDS

Frequencies (MHz)	EIRP Limit (dBm)	Equivalent Field Strength at 3m (dBμV/m)
5150-5250	-27	68.3
5250-5350	-27	68.3
5470-5725	-27	68.3
5725-5850	-27(Note 2)	68.3
	10 (Note 2)	105.3
	15.6 (Note 2)	110.9
	27 (Note 2)	122.3

Note:

1. The following formula is used to convert the equipment isotropic radiated power (eirp) to field strength: $E = \frac{1000000\sqrt{30P}}{3}$ μV/m, where P is the eirp (Watts)
2. According to FCC 16-24, All emissions shall be limited to a level of -27 dBm/MHz at 75 MHz or more above or below the band edge increasing linearly to 10 dBm/MHz at 25 MHz above or below the band edge, and from 25MHz above or below the band edge increasing linearly to a level of 15.6 dBm/MHz at 5 MHz above or below the band edge, and from 5 MHz above or below the band edge increasing linearly to a level of 27dBm/MHz at the band edge.

4.2.2 TEST PROCEDURE

- a. The measuring distance of at 3 m shall be used for measurements. The EUT was placed on the top of a rotating table 0.8 meter above the ground at a 3 meter semi-anechoic chamber. The table was rotated 360 degrees to determine the position of the highest radiation.(below 1GHz)
- b. The measuring distance of at 3 m shall be used for measurements. The EUT was placed on the top of a rotating table 1.5 meter above the ground at a 3 meter semi-anechoic chamber. The table was rotated 360 degrees to determine the position of the highest radiation.(above 1GHz)
- c. The height of the equipment or of the substitution antenna shall be 0.8 m or 1.5 m; the height of the test antenna shall vary between 1 m to 4 m. Both horizontal and vertical polarizations of the antenna are set to make the measurement.
- d. The initial step in collecting conducted emission data is a receiver peak detector mode pre-scanning the measurement frequency range. Significant peaks are then marked and then Quasi Peak detector mode re-measured.
- e. If the Peak Mode measured value compliance with and lower than Quasi Peak Mode Limit, the EUT shall be deemed to meet QP Limits and then no additional QP Mode measurement performed.
- f. For the actual test configuration, please refer to the related Item –EUT Test Photos.

4.2.3 DEVIATION FROM TEST STANDARD

No deviation

4.2.4 TEST SETUP

(A)Radiated Emission Test Set-Up Frequency Below 1GHz

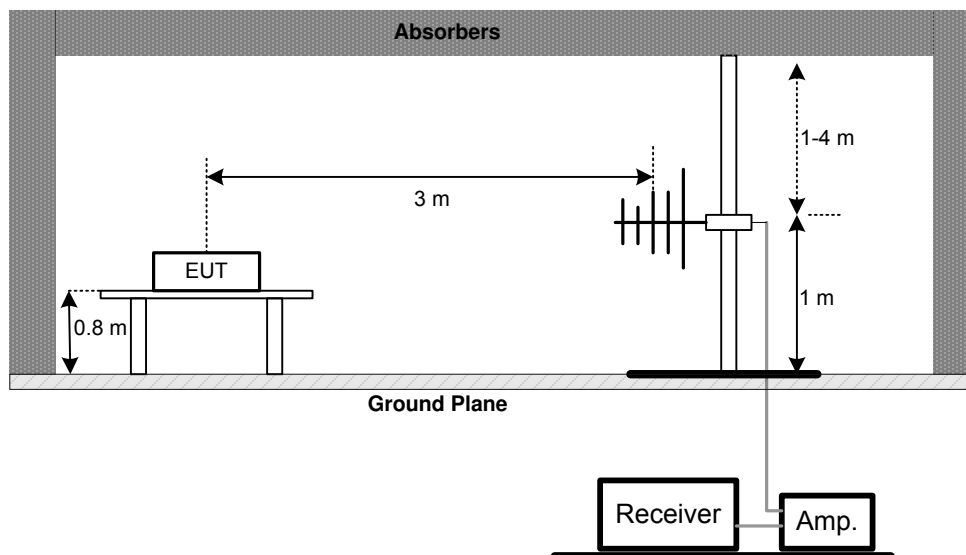

(B) Radiated Emission Test Set-Up Frequency Above 1 GHz

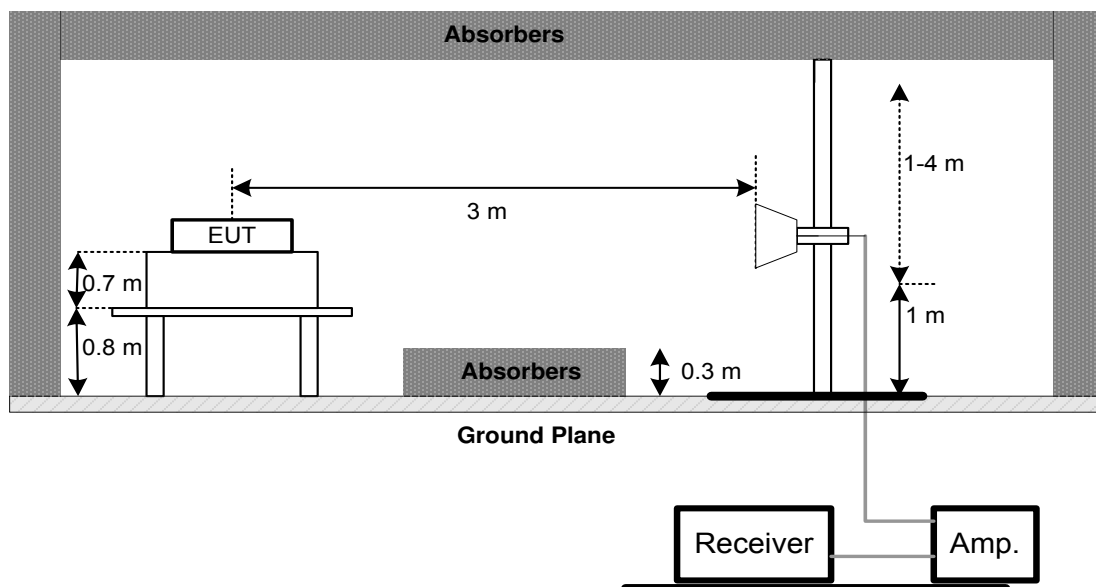

(C) Radiated emissions below 30MHz

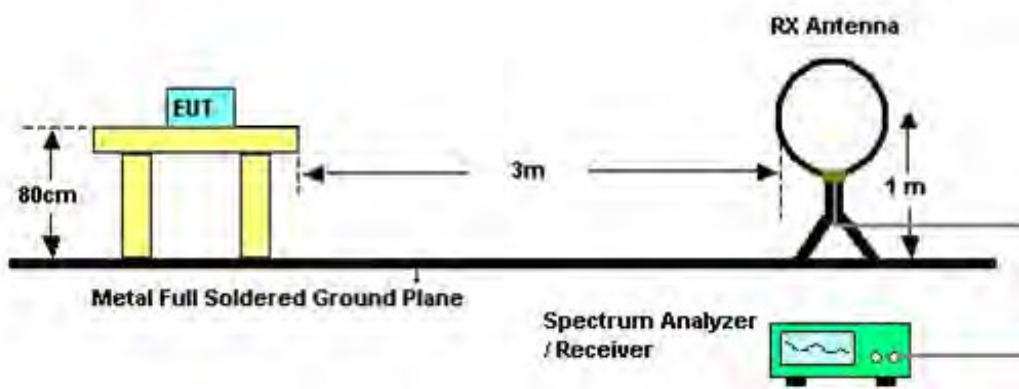

4.2.5 EUT OPERATING CONDITIONS

The EUT tested system was configured as the statements of 4.1.5 unless otherwise a special operating condition is specified in the follows during the testing.

4.2.6 EUT TEST CONDITIONS

Temperature: 24°C Relative Humidity: 52% Test Voltage: AC 120V/60Hz

4.2.7 TEST RESULTS (9K TO 30MHz)

Please refer to the Attachment B

Remark:

- (1) The amplitude of spurious emissions which are attenuated by more than 20 dB below the permissible value has no need to be reported.
- (2) Distance extrapolation factor = $40 \log(\text{specific distance} / \text{test distance})$ (dB);
- (3) Limit line = specific limits (dBuV) + distance extrapolation factor.

4.2.8 TEST RESULTS (BETWEEN 30 TO 1000 MHz)

Please refer to the Attachment C.

Remark:

- (1) Reading in which marked as QP or Peak means measurements by using are Quasi-Peak Mode or Peak Mode with Detector BW=120kHz ; SPA setting in RBW=120kHz, VBW =120kHz, Swp. Time = 0.3 sec./MHz ◦
- (2) All readings are Peak unless otherwise stated QP in column of 『Note』 . Peak denotes that the Peak reading compliance with the QP Limits and then QP Mode measurement didn't perform ◦
- (3) Measuring frequency range from 30MHz to 1000MHz ◦
- (4) If the peak scan value lower limit more than 20dB, then this signal data does not show in table ◦

4.2.9 TEST RESULTS (ABOVE 1000 MHz)

Please refer to the Attachment D.

Remark:

- (1) Spectrum Setting: 30MHz – 1000MHz , RBW= 100kHz, VBW=100kHz, Sweep time = 200 ms. 1GHz- 40GHz, RBW= 1MHz, VBW= 1MHz, Sweep time = Auto
- (2) All readings are Peak unless otherwise stated AV in column of 『Note』 . Peak denotes that the Peak reading compliance with the AV Limits and then AV Mode measurement didn't perform.
- (3) Radiated emissions measured in frequency range above 1000MHz were made with an instrument using Peak detector mode and AV detector mode of the emission ◦
- (4) Data of measurement within this frequency range shown “ * ” in the table above means the reading of emissions are attenuated more than 20dB below the permissible limits or the field strength is too small to be measured.
- (5) A preamp and high pass filter were used for this test in order to provide sufficient measurement sensitivity.
- (6) EUT Orthogonal Axes:
“X” - denotes Laid on Table ; “Y” - denotes Vertical Stand ; “Z” - denotes Side Stand
- (7) During the measurements above 1GHz it is taken care of that the EUT is always within the 3dB cone of radiation BW of the used antenna.
- (8) No limit: This is fundamental signal, the judgment is not applicable.
For fundamental signal judgment was referred to Peak output test.

5. 26dB SPECTRUM BANDWIDTH

5.1 APPLIED PROCEDURES / LIMIT

FCC Part15, Subpart E			
Test Item	Limit	Frequency Range (MHz)	Result
Bandwidth	26 dB Bandwidth	5150-5250	PASS
	Minimum 500kHz 6dB Bandwidth	5725-5850	PASS

5.1.1 TEST PROCEDURE

a. The EUT was directly connected to the spectrum analyzer and antenna output port as show in the block diagram below,

b.

Spectrum Parameters	Setting
Attenuation	Auto
Span Frequency	> 26dB Bandwidth
RBW	300 kHz
VBW	1000 kHz
Detector	Peak
Trace	Max Hold
Sweep Time	Auto

c. Measured the spectrum width with power higher than 26dB below carrier

5.1.2 DEVIATION FROM STANDARD

No deviation.

5.1.3 TEST SETUP



5.1.4 EUT OPERATION CONDITIONS

The EUT tested system was configured as the statements of 4.1.5 unless otherwise a special operating condition is specified in the follows during the testing.

5.1.5 EUT TEST CONDITIONS

Temperature: 24°C Relative Humidity: 52% Test Voltage: AC 120V/60Hz

5.1.6 TEST RESULTS

Please refer to the Attachment E.

6. MAXIMUM CONDUCTED OUTPUT POWER

6.1 APPLIED PROCEDURES / LIMIT

FCC Part15, Subpart E			
Test Item	Limit	Frequency Range (MHz)	Result
Conducted Output Power	Fixed:1 Watt (30dBm) Mobile and portable: 250mW (24dBm)	5150-5250	PASS
	1 Watt (30dBm)	5725-5850	PASS
Note: The maximum e.i.r.p at anyelevation angle above 30 degrees as measured from the horizon must not exceed 125mW(21dBm)			

6.1.1 TEST PROCEDURE

- a. The EUT was directly connected to the power meter and antenna output port as show in the block diagram below,
- b.

Spectrum Parameter	Setting
Attenuation	Auto
Span Frequency	Encompass the entire emissions bandwidth (EBW) of the signal
RBW	= 1MHz.
VBW	\geq 3MHz.
Detector	RMS
Trace	Max Hold
Sweep Time	auto

- c. Test was performed in accordance with method of KDB 789033 D02.

6.1.2 DEVIATION FROM STANDARD

No deviation.

6.1.3 TEST SETUP

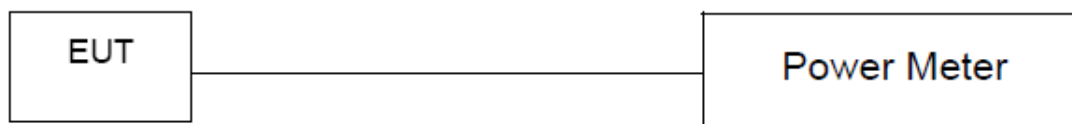

6.1.4 EUT OPERATION CONDITIONS

The EUT tested system was configured as the statements of 4.1.5 unless otherwise a special operating condition is specified in the follows during the testing.

6.1.5 EUT TEST CONDITIONS

Temperature: 24°C Relative Humidity: 52% Test Voltage: AC 120V/60Hz

6.1.6 TEST RESULTS

Please refer to the Attachment F.

7. POWER SPECTRAL DENSITY TEST

7.1 APPLIED PROCEDURES / LIMIT

FCC Part15, Subpart E			
Test Item	Limit	Frequency Range (MHz)	Result
Power Spectral Density	Other then Mobile and portable:17dBm/MHz Mobile and portable:11dBm/MHz	5150-5250	PASS
	30dBm/500kHz	5725-5850	PASS

8.1.1 TEST PROCEDURE

a. The EUT was directly connected to the spectrum analyzer and antenna output port as show in the block diagram below,

b.

Spectrum Parameter	Setting
Attenuation	Auto
Span Frequency	Encompass the entire emissions bandwidth (EBW) of the signal
RBW	= 1MHz.
VBW	≥ 3MHz.
Detector	RMS
Trace average	100 trace
Sweep Time	Auto

Note:

- For UNII-3, according to KDB publication 789033 D02 General UNII Test Procedures New Rules v01, section II.F.5., it is acceptable to set RBW at 1MHz and VBW at 3MHz if the spectrum analyzer does not have 500kHz RBW.
- The value measured with RBW=1MHz is to be added with $10\log(500\text{kHz}/1\text{MHz})$ which is -3dB. For example, if the measured value is +10dBm using RBW=1MHz (that is +10dBm/MHz), then the converted value will be +7dBm/500kHz.

7.1.1 DEVIATION FROM STANDARD

No deviation.

7.1.2 TEST SETUP



7.1.3 EUT OPERATION CONDITIONS

The EUT tested system was configured as the statements of 4.1.5 unless otherwise a special operating condition is specified in the follows during the testing.

7.1.4 EUT TEST CONDITIONS

Temperature: 24°C Relative Humidity: 52% Test Voltage: AC 120V/60Hz

7.1.5 TEST RESULTS

Please refer to the Attachment G.

8. FREQUENCY STABILITY MEASUREMENT

8.1 APPLIED PROCEDURES / LIMIT

FCC Part15, Subpart E			
Test Item	Limit	Frequency Range (MHz)	Result
FSpecified in the user's manual Specified in the user's manual frequency Stability	Specified in the user's manual	5150-5250	PASS
		5725-5850	PASS

8.1.1 TEST PROCEDURE

a. The EUT was directly connected to the spectrum analyzer and antenna output port as show in the block diagram below,

b.

Spectrum Parameter	Setting
Attenuation	Auto
Span Frequency	Entire absence of modulation emissions bandwidth
RBW	10 kHz
VBW	10 kHz
Sweep Time	Auto

c. The test extreme voltage is to change the primary supply voltage from 85 to 115 percent of the nominal value.

d. User manual temperature is 0°C~40°C.

8.1.2 DEVIATION FROM STANDARD

No deviation.

8.1.3 TEST SETUP

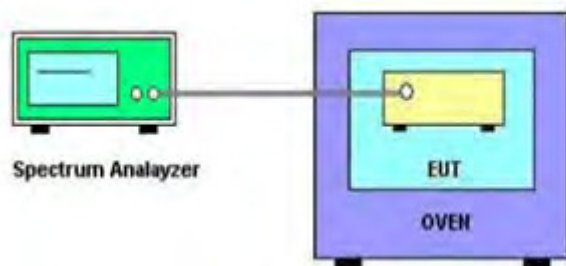

8.1.4 EUT OPERATION CONDITIONS

The EUT tested system was configured as the statements of 4.1.5 unless otherwise a special operating condition is specified in the follows during the testing.

8.1.5 EUT TEST CONDITIONS

Temperature: 25°C Relative Humidity: 55% Test Voltage: AC 120V/60Hz

8.1.6 TEST RESULTS

Please refer to the Attachment H.

9. MEASUREMENT INSTRUMENTS LIST

Conducted Emission Measurement					
Item	Kind of Equipment	Manufacturer	Type No.	Serial No.	Calibrated until
1	LISN	EMCO	3816/2	0052765	Mar. 27, 2017
2	LISN	R&S	ENV216	101447	Mar. 27, 2017
3	Test Cable	emci	RG223(9KHz-30MHz)	C_17	Mar. 10, 2017
4	EMI Test Receiver	R&S	ESCI	100382	Mar. 27, 2017
5	50Ω Terminator	SHX	TF2-3G-A	08122901	Mar. 27, 2017
6	Measurement Software	Farad	EZ-EMC Ver.NB-03A1-01	N/A	N/A

Radiated Emission Measurement					
Item	Kind of Equipment	Manufacturer	Type No.	Serial No.	Calibrated until
1	Antenna	Schwarzbeck	VULB9160	9160-3232	Mar. 27, 2017
2	Amplifier	HP	8447D	2944A09673	Nov. 09, 2016
3	Receiver	AGILENT	N9038A	MY5213003 9	Oct. 11, 2016
4	Test Cable	emci	LMR-400(30MHz-1GHz)	C-01	Jun. 28, 2016
5	Control	CT	SC100	N/A	N/A
6	Position Control	MF	MF-7802	MF78020841 6	N/A
7	Antenna	ETS	3115	00075789	Mar. 27, 2017
8	Amplifier	Agilent	8449B	3008A02274	Nov. 01, 2016
9	Receiver	AGILENT	N9038A	MY5213003 9	Oct. 11, 2016
10	Test Cable	emci	EMC104-SM-SM-10000(1GHz-26.5GHz)	C-68	Jun. 28, 2016
11	Broad-Band Horn Antenna	Schwarzbeck	BBHA 9170	9170319	Apr. 23, 2017
12	Microwave Preamplifier With Adaptor	EMC INSTRUMENT	EMC2654045	980039 & HA01	Mar. 27, 2017
13	Active Loop Antenna	R&S	HFH2-Z2	830749/020	Sep. 07, 2016
14	Measurement Software	Farad	EZ-EMC Ver.NB-03A1-01	N/A	N/A

Spectrum Bandwidth Measurement					
Item	Kind of Equipment	Manufacturer	Type No.	Serial No.	Calibrated until
1	Spectrum Analyzer	R&S	FSP 40	100185	Oct. 11, 2016

Maximum Conducted Output Power Measurement					
Item	Kind of Equipment	Manufacturer	Type No.	Serial No.	Calibrated until
1	power Meter	ANRITSU	ML2495A	1128009	Apr. 26, 2017
2	Pulse Power Sensor	ANRITSU	MA 2411B	1027500	Apr. 26, 2017

Power Spectral Density Measurement					
Item	Kind of Equipment	Manufacturer	Type No.	Serial No.	Calibrated until
1	Spectrum Analyzer	R&S	FSP 40	100185	Oct. 11, 2016

Frequency Stability Measurement					
Item	Kind of Equipment	Manufacturer	Type No.	Serial No.	Calibrated until
1	Spectrum Analyzer	R&S	FSP 40	100185	Oct. 11, 2016
2	Const Temp. & Humidity Chamber	Giant Force	ITH-225-20-S	IAB0309-001	Dec.04, 2016

Remark: "N/A" denotes no model name, serial no. or calibration specified.
 All calibration period of equipment list is one year.

10. EUT TEST PHOTOS

Conducted Measurement Photos



Radiated Measurement Photos

9KHz to 30MHz

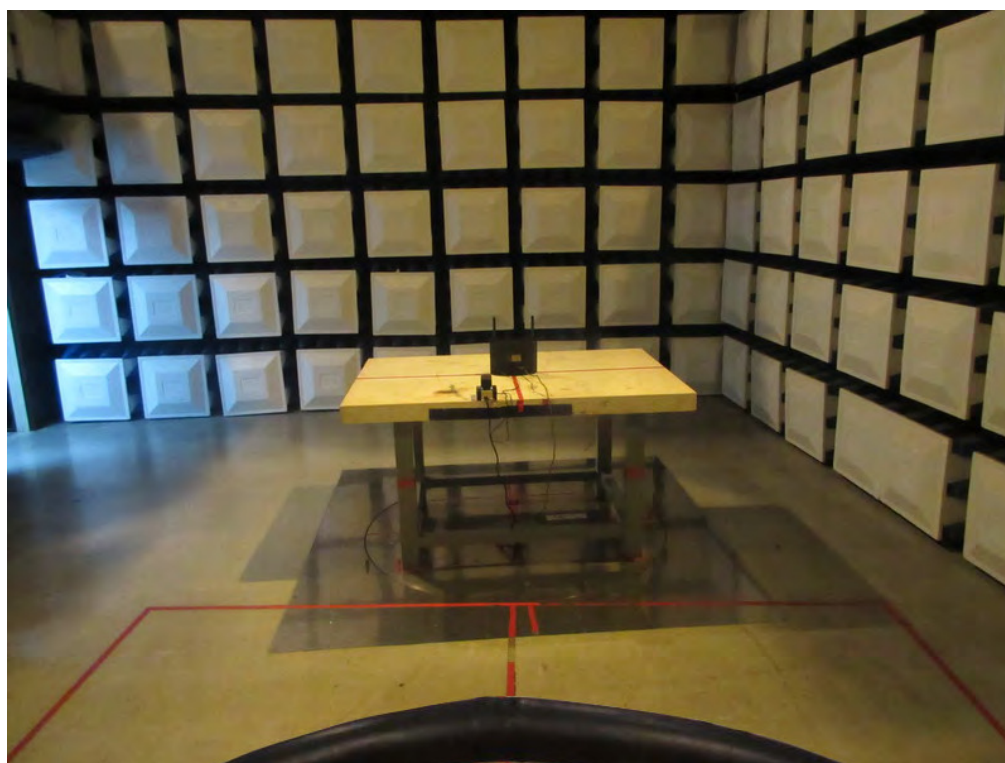

Radiated Measurement Photos

30MHz to 1000MHz

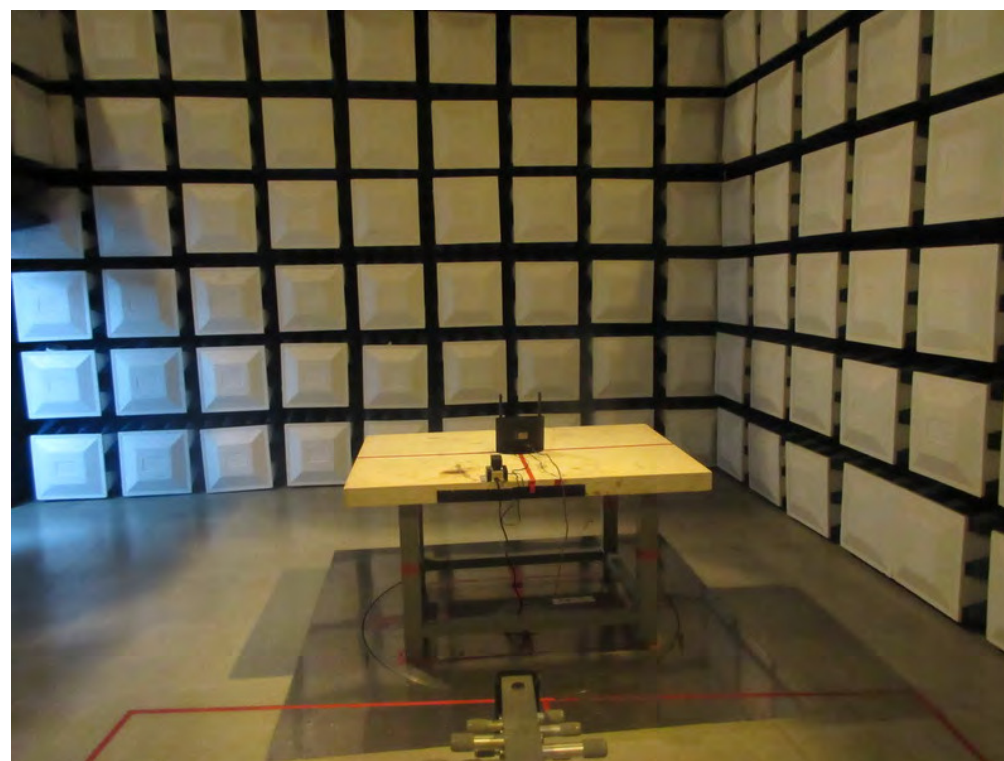
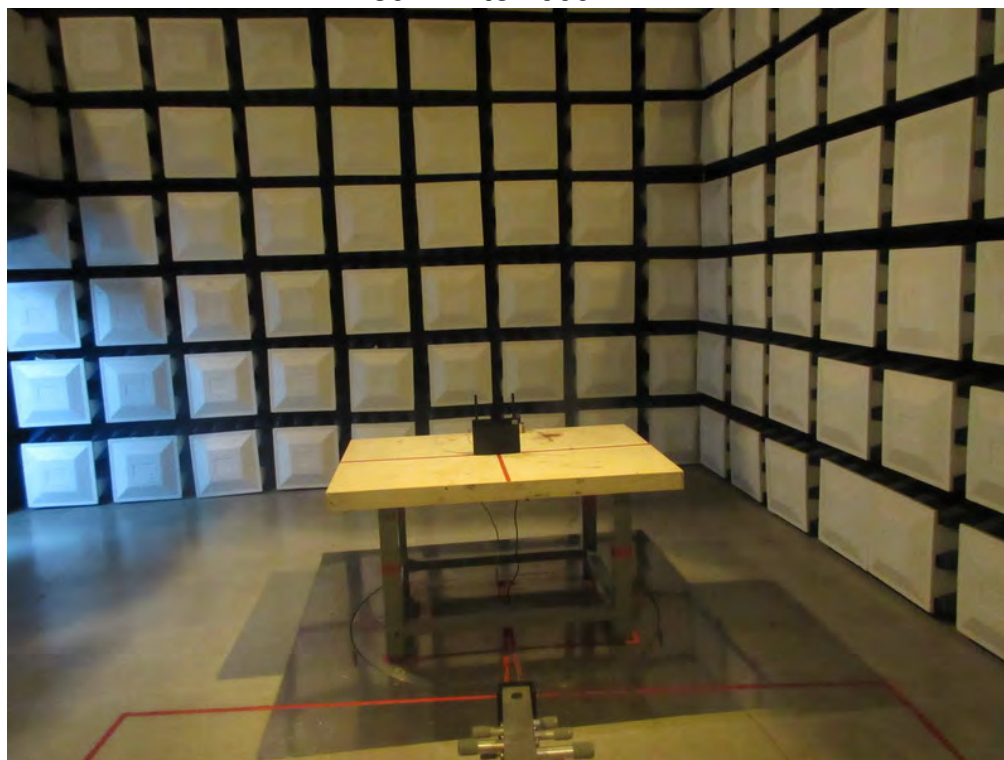

Radiated Measurement Photos

Above 1000MHz

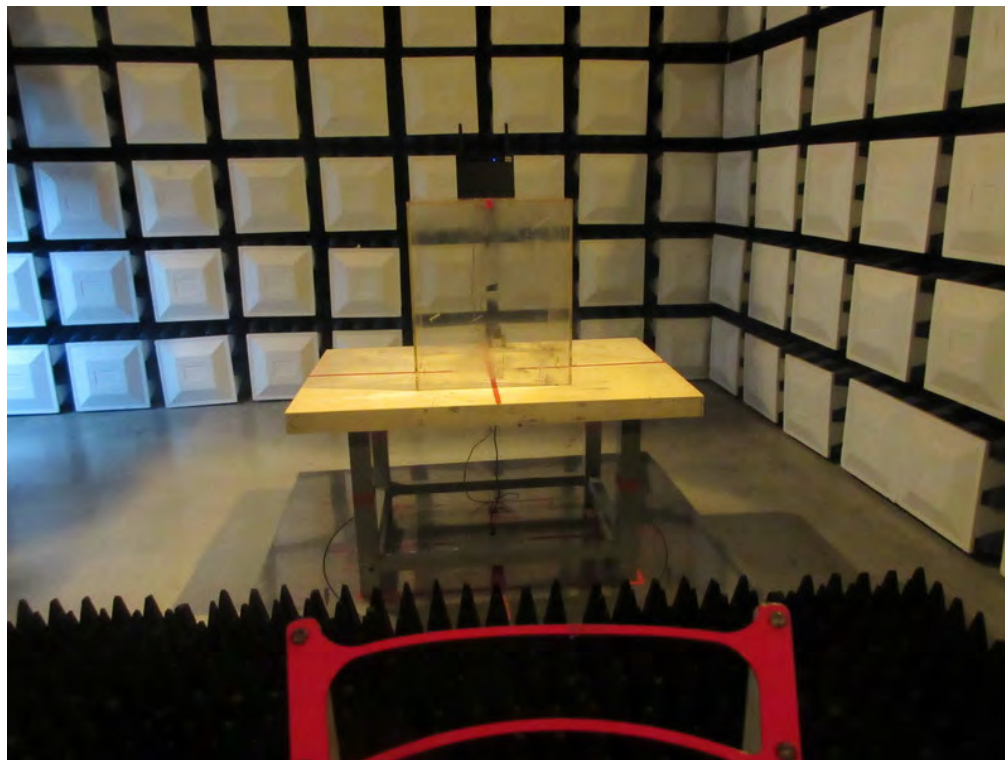

ATTACHMENT A - CONDUCTED EMISSION

Test Mode:	TX MODE
------------	---------

Line

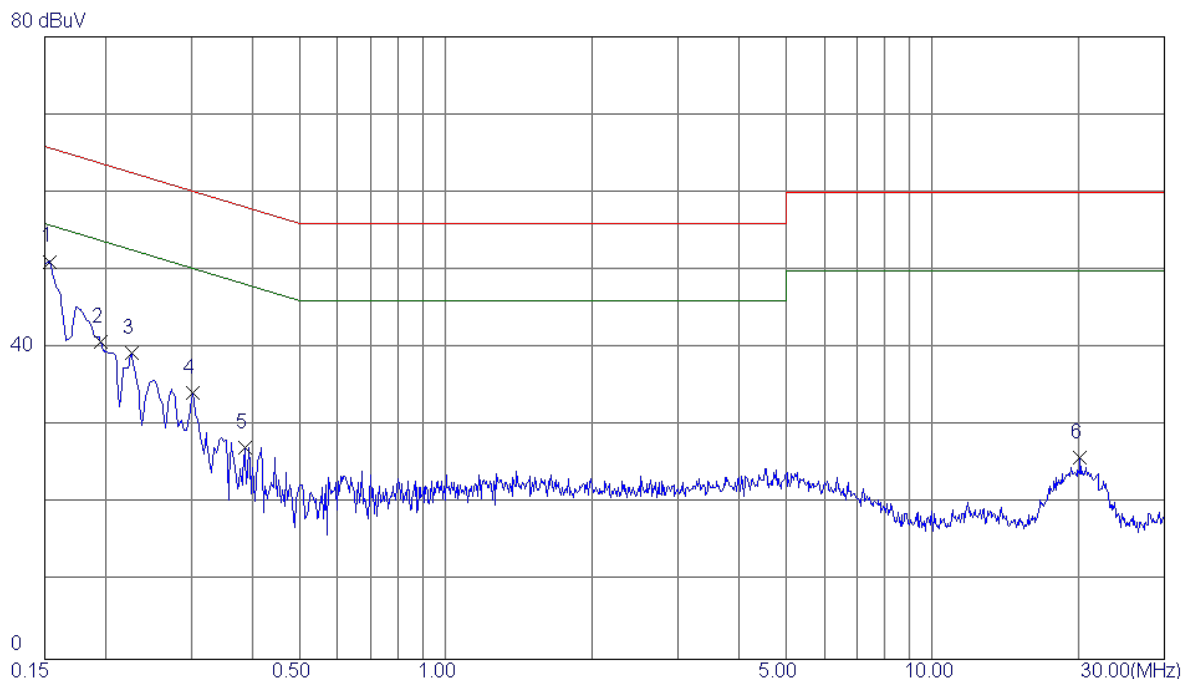

No.	Freq. MHz	Reading Level dBuV	Correct Factor dB	Measure ment dBuV	Limit dBuV	Margin dB	Detector	Comment
1 *	0.1539	41.60	9.52	51.12	65.79	-14.67	Peak	
2	0.1955	31.19	9.56	40.75	63.80	-23.05	Peak	
3	0.2260	29.80	9.58	39.38	62.60	-23.22	Peak	
4	0.3020	24.68	9.63	34.31	60.19	-25.88	Peak	
5	0.3860	17.60	9.66	27.26	58.15	-30.89	Peak	
6	20.0780	16.01	9.85	25.86	60.00	-34.14	Peak	

Note : The test result has included the cable loss.

Test Mode:	TX MODE
------------	---------

Neutral

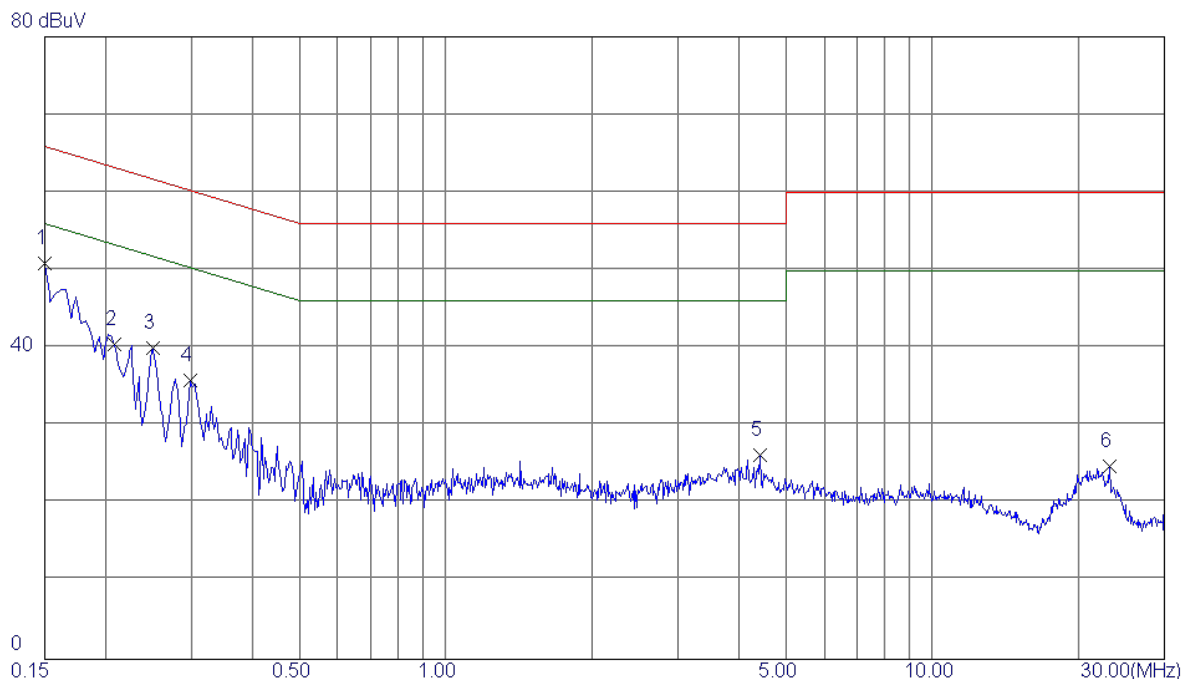

No.	Freq. MHz	Reading Level dBuV	Correct Factor dB	Measure ment dBuV	Limit dBuV	Margin dB	Detector	Comment
1 *	0.1500	41.39	9.47	50.86	66.00	-15.14	Peak	
2	0.2083	30.93	9.49	40.42	63.27	-22.85	Peak	
3	0.2500	30.55	9.50	40.05	61.76	-21.71	Peak	
4	0.2980	26.28	9.51	35.79	60.30	-24.51	Peak	
5	4.4300	16.42	9.88	26.30	56.00	-29.70	Peak	
6	23.1460	14.73	10.00	24.73	60.00	-35.27	Peak	

Note : The test result has included the cable loss.

ATTACHMENT B - RADIATED EMISSION (9KHZ TO 30MHZ)

Test Mode:	TX MODE
------------	---------

Frequency (MHz)	Ant 0°/90°	Read level dBuV/m	Factor (dB)	Measured(FS) (dBuV/m)	Limit (dBuV/m)	Margin (dB)	Note
0.0114	0°	13.28	24.8447	38.1247	126.4661	-88.3415	AVG
0.0114	0°	14.53	24.8447	39.3747	146.4661	-107.0915	PEAK
0.0217	0°	6.51	24.1923	30.7023	120.8750	-90.1727	AVG
0.0217	0°	8.44	24.1923	32.6323	140.8750	-108.2427	PEAK
0.0366	0°	3.77	23.2487	27.0187	116.3346	-89.3159	AVG
0.0366	0°	5.91	23.2487	29.1587	136.3346	-107.1759	PEAK
0.0511	0°	1.52	22.3780	23.8980	113.4358	-89.5378	AVG
0.0511	0°	2.37	22.3780	24.7480	133.4358	-108.6878	PEAK
0.5073	0°	19.73	19.8234	39.5534	73.4989	-33.9456	QP
1.9532	0°	23.17	19.5047	42.6747	69.5400	-26.8653	QP

Frequency (MHz)	Ant 0°/90°	Read level dBuV/m	Factor (dB)	Measured(FS) (dBuV/m)	Limit (dBuV/m)	Margin (dB)	Note
0.0129	90°	13.38	24.3000	37.6800	125.3924	-87.7124	AVG
0.0129	90°	14.53	24.3000	38.8300	145.3924	-106.5624	PEAK
0.0236	90°	7.56	24.0720	31.6320	120.1460	-88.5140	AVG
0.0236	90°	8.27	24.0720	32.3420	140.1460	-107.8040	PEAK
0.0432	90°	5.19	22.8307	28.0207	114.8945	-86.8739	AVG
0.0432	90°	6.23	22.8307	29.0607	134.8945	-105.8339	PEAK
0.0513	90°	1.46	22.3740	23.8340	113.4019	-89.5679	AVG
0.0513	90°	2.23	22.3740	24.6040	133.4019	-108.7979	PEAK
0.6204	90°	22.68	20.1853	42.8653	71.7508	-28.8855	QP
2.0535	90°	24.38	19.4679	43.8479	69.5400	-25.6921	QP

ATTACHMENT C - RADIATED EMISSION (30MHZ TO 1000MHZ)

Test Mode: UNII-1/TX A Mode 5180MHz

Vertical

80 dBuV/m

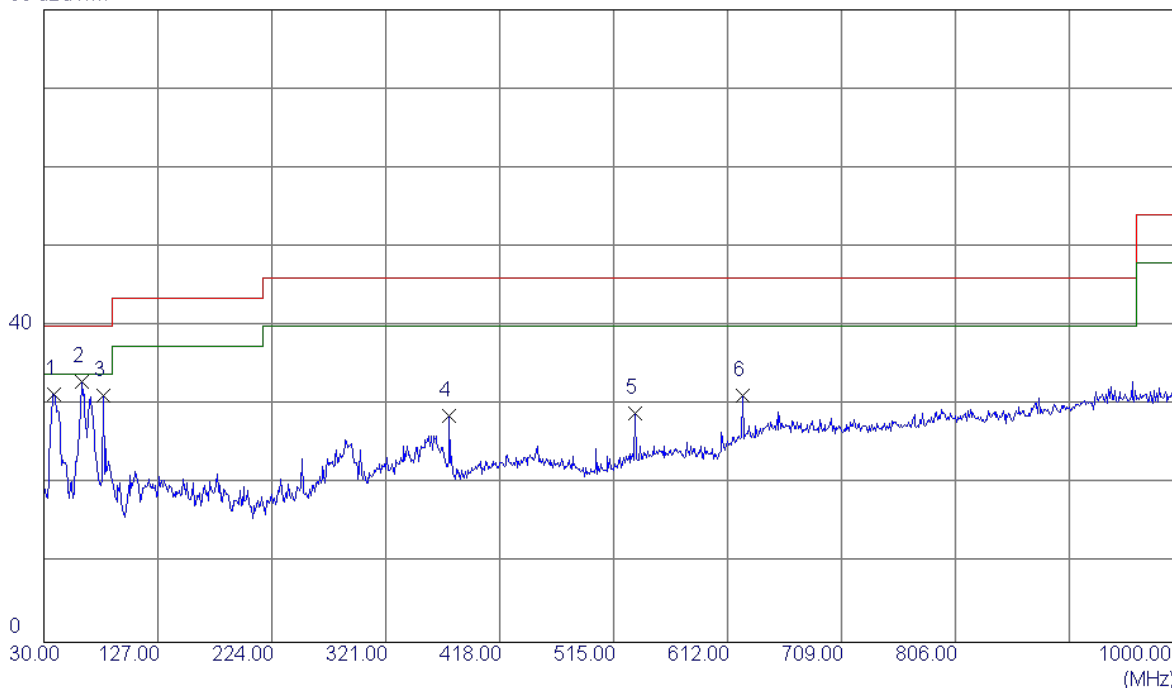

No.	Freq. MHz	Reading Level dBuV/m	Correct Factor dB	Measure ment dBuV/m	Limit dBuV/m	Margin dB	Detector	Comment
1	38.7300	44.25	-12.83	31.42	40.00	-8.58	Peak	
2 *	62.0100	46.73	-13.82	32.91	40.00	-7.09	Peak	
3	80.4400	46.92	-15.72	31.20	40.00	-8.80	Peak	
4	375.3200	37.23	-8.58	28.65	46.00	-17.35	Peak	
5	533.4300	34.57	-5.54	29.03	46.00	-16.97	Peak	
6	624.6100	34.43	-3.16	31.27	46.00	-14.73	Peak	

Test Mode: UNII-1/TX A Mode 5180MHz

Horizontal

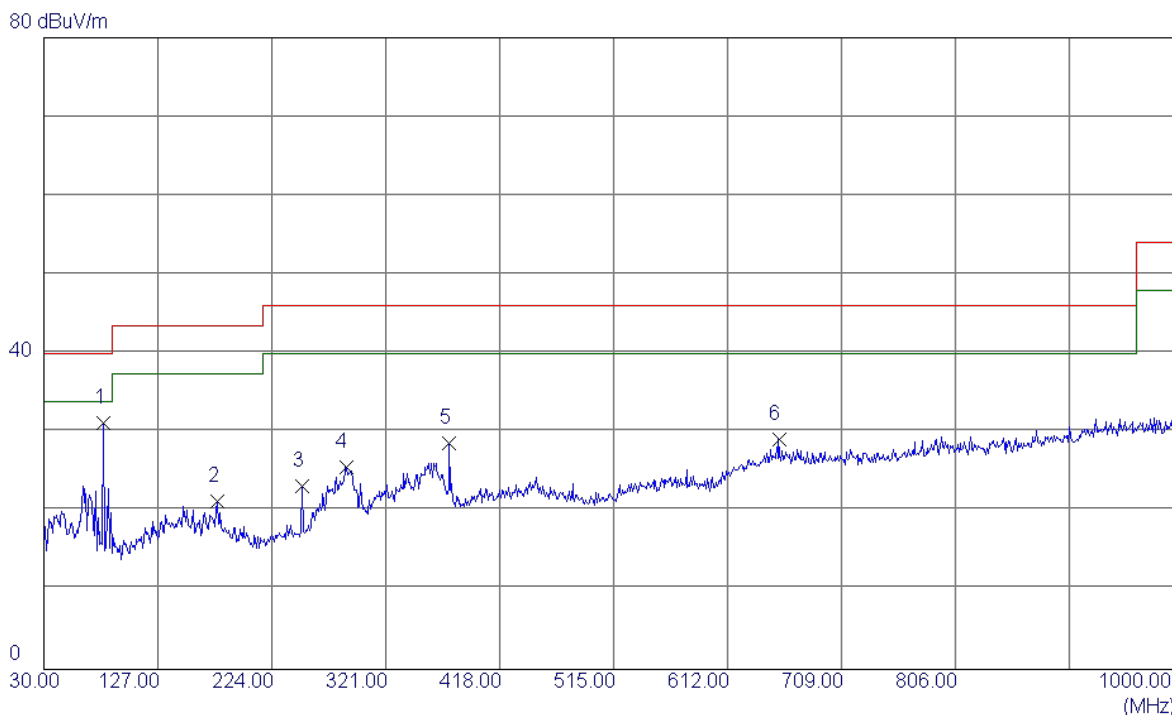

No.	Freq. MHz	Reading Level dBuV/m	Correct Factor dB	Measure ment dBuV/m	Limit dBuV/m	Margin dB	Detector	Comment
1 *	80.4400	46.92	-15.72	31.20	40.00	-8.80	Peak	
2	177.4400	32.72	-11.38	21.34	43.50	-22.16	Peak	
3	250.1900	35.83	-12.67	23.16	46.00	-22.84	Peak	
4	287.0500	35.74	-10.19	25.55	46.00	-20.45	Peak	
5	375.3200	37.23	-8.58	28.65	46.00	-17.35	Peak	
6	655.6500	30.69	-1.62	29.07	46.00	-16.93	Peak	

Test Mode: UNII-1/TX A Mode 5200MHz

Vertical

80 dBuV/m

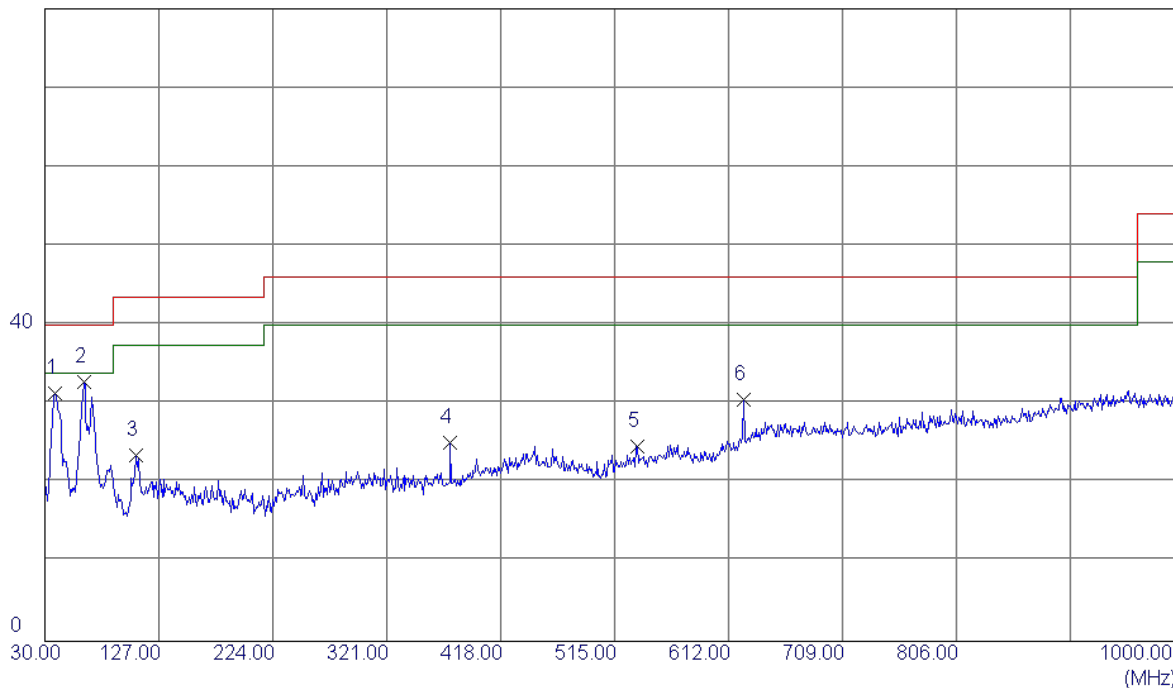

No.	Freq. MHz	Reading Level dBuV/m	Correct Factor dB	Measure ment dBuV/m	Limit dBuV/m	Margin dB	Detector	Comment
1	38.7300	44.16	-12.83	31.33	40.00	-8.67	Peak	
2 *	62.9800	46.75	-13.89	32.86	40.00	-7.14	Peak	
3	107.6000	37.46	-14.01	23.45	43.50	-20.05	Peak	
4	375.3200	33.67	-8.58	25.09	46.00	-20.91	Peak	
5	534.4000	30.19	-5.48	24.71	46.00	-21.29	Peak	
6	624.6100	33.79	-3.16	30.63	46.00	-15.37	Peak	

Test Mode: UNII-1/TX A Mode 5200MHz

Horizontal

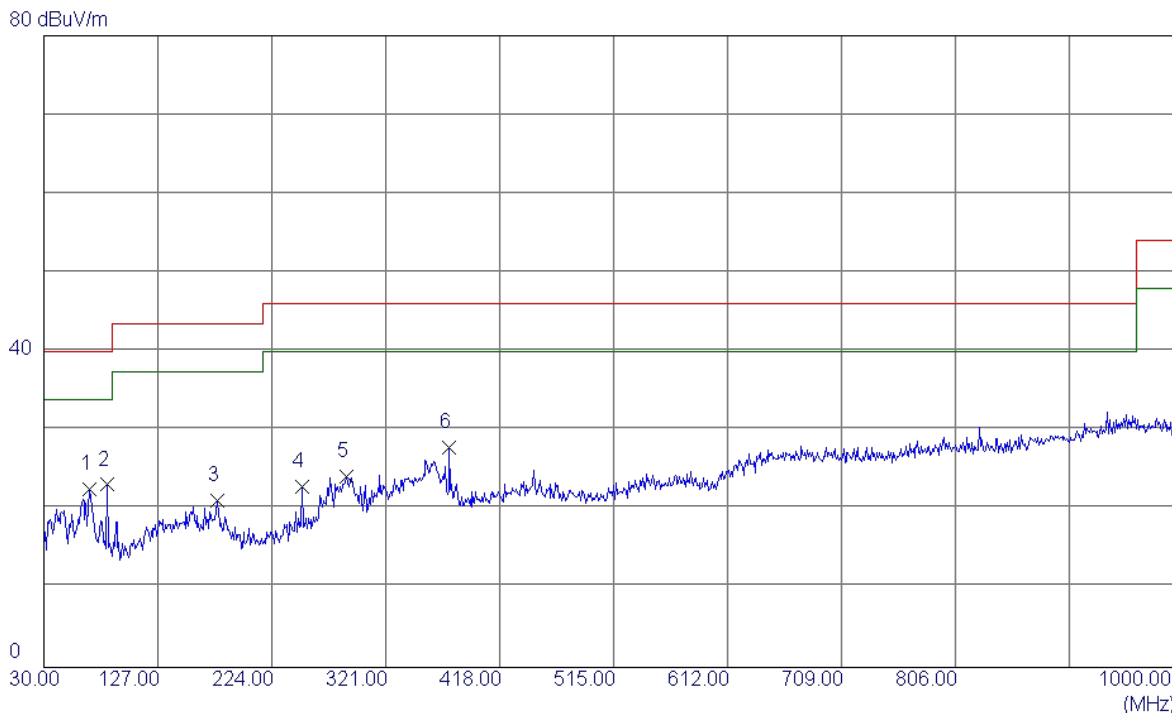

No.	Freq. MHz	Reading Level dBuV/m	Correct Factor dB	Measure ment dBuV/m	Limit dBuV/m	Margin dB	Detector	Comment
1	68.8000	37.16	-14.61	22.55	40.00	-17.45	Peak	
2 *	84.3200	38.97	-15.85	23.12	40.00	-16.88	Peak	
3	177.4400	32.53	-11.38	21.15	43.50	-22.35	Peak	
4	250.1900	35.49	-12.67	22.82	46.00	-23.18	Peak	
5	288.0200	34.28	-10.07	24.21	46.00	-21.79	Peak	
6	375.3200	36.43	-8.58	27.85	46.00	-18.15	Peak	

Test Mode: UNII-1/TX A Mode 5240MHz

Vertical

80 dBuV/m

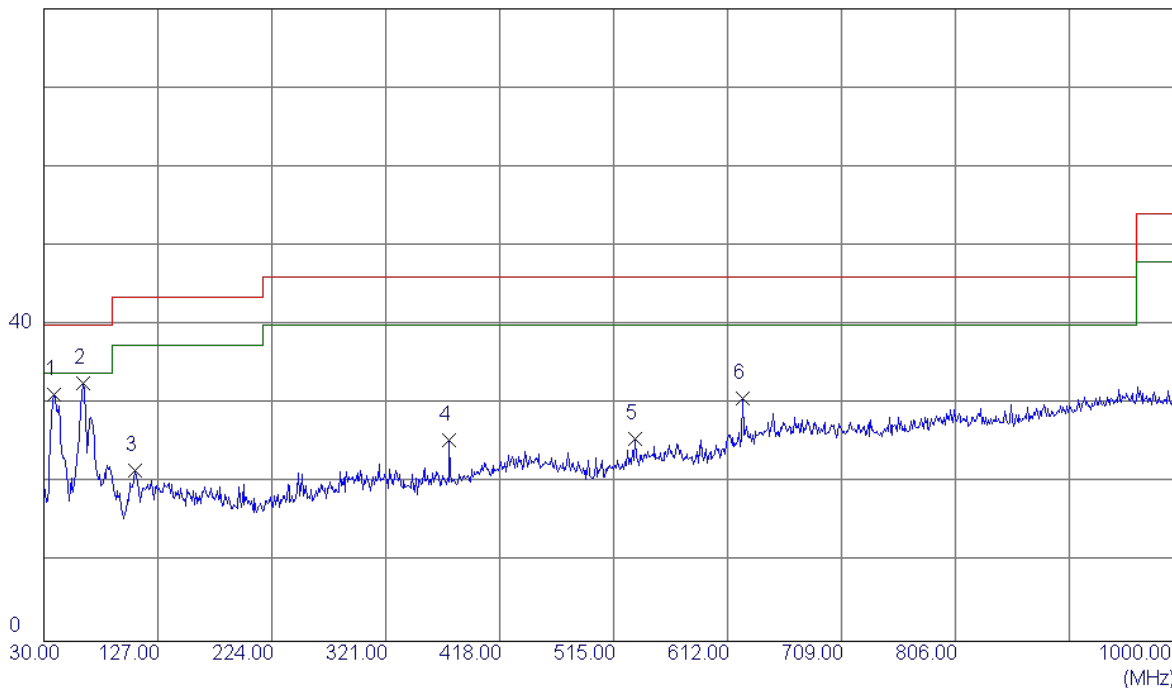

No.	Freq. MHz	Reading Level dBuV/m	Correct Factor dB	Measure ment dBuV/m	Limit dBuV/m	Margin dB	Detector	Comment
1	38.7300	44.00	-12.83	31.17	40.00	-8.83	Peak	
2 *	62.9800	46.50	-13.89	32.61	40.00	-7.39	Peak	
3	107.6000	35.63	-14.01	21.62	43.50	-21.88	Peak	
4	375.3200	33.98	-8.58	25.40	46.00	-20.60	Peak	
5	533.4300	31.07	-5.54	25.53	46.00	-20.47	Peak	
6	624.6100	33.92	-3.16	30.76	46.00	-15.24	Peak	

Test Mode: UNII-1/TX A Mode 5240MHz

Horizontal

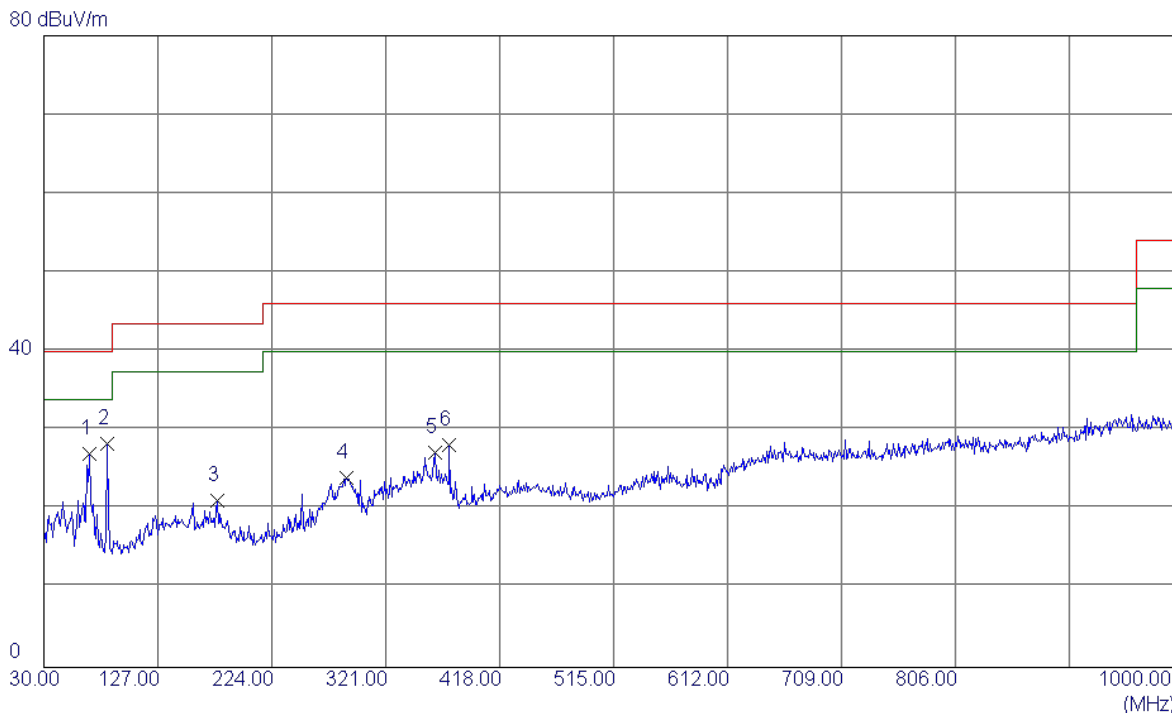

No.	Freq. MHz	Reading Level dBuV/m	Correct Factor dB	Measure ment dBuV/m	Limit dBuV/m	Margin dB	Detector	Comment
1	68.8000	41.60	-14.61	26.99	40.00	-13.01	Peak	
2 *	84.3200	44.21	-15.85	28.36	40.00	-11.64	Peak	
3	177.4400	32.57	-11.38	21.19	43.50	-22.31	Peak	
4	288.0200	34.02	-10.07	23.95	46.00	-22.05	Peak	
5	362.7100	36.48	-9.25	27.23	46.00	-18.77	Peak	
6	375.3200	36.74	-8.58	28.16	46.00	-17.84	Peak	

Test Mode: UNII-3/TX A Mode 5745MHz

Vertical

80 dBuV/m

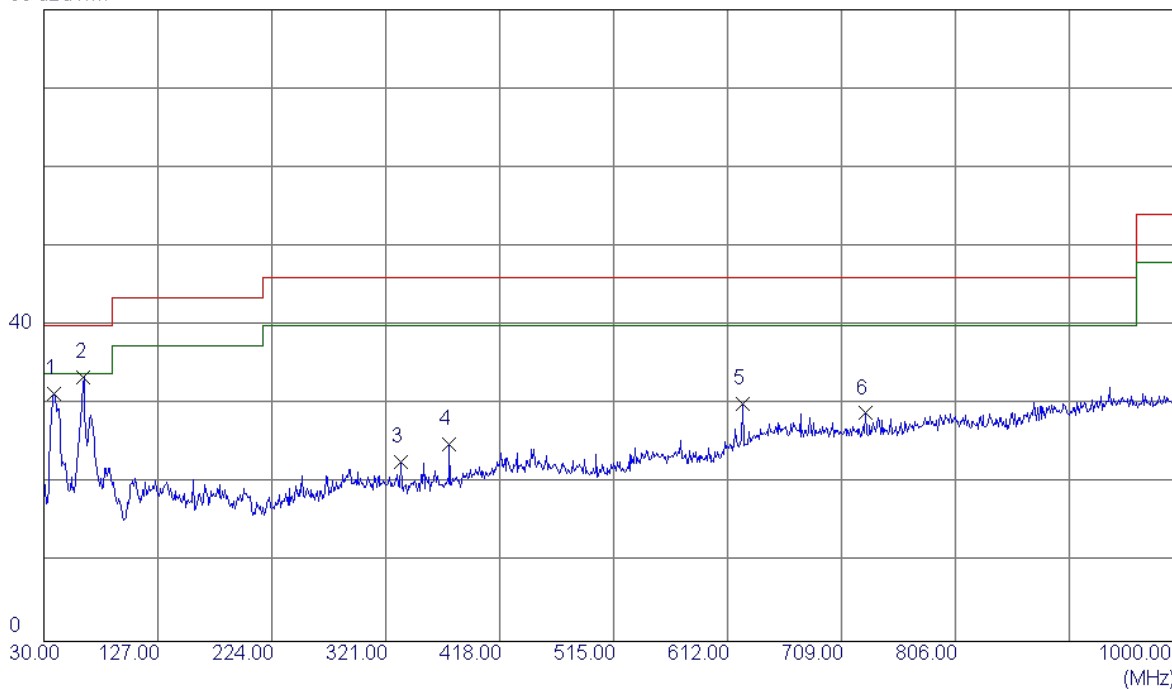

No.	Freq. MHz	Reading Level dBuV/m	Correct Factor dB	Measure ment dBuV/m	Limit dBuV/m	Margin dB	Detector	Comment
1	38.7300	44.14	-12.83	31.31	40.00	-8.69	Peak	
2 *	63.9500	47.41	-13.96	33.45	40.00	-6.55	Peak	
3	333.6099	32.57	-9.81	22.76	46.00	-23.24	Peak	
4	375.3200	33.56	-8.58	24.98	46.00	-21.02	Peak	
5	624.6100	33.26	-3.16	30.10	46.00	-15.90	Peak	
6	729.3700	30.32	-1.44	28.88	46.00	-17.12	Peak	

Test Mode: UNII-3/TX A Mode 5745MHz

Horizontal

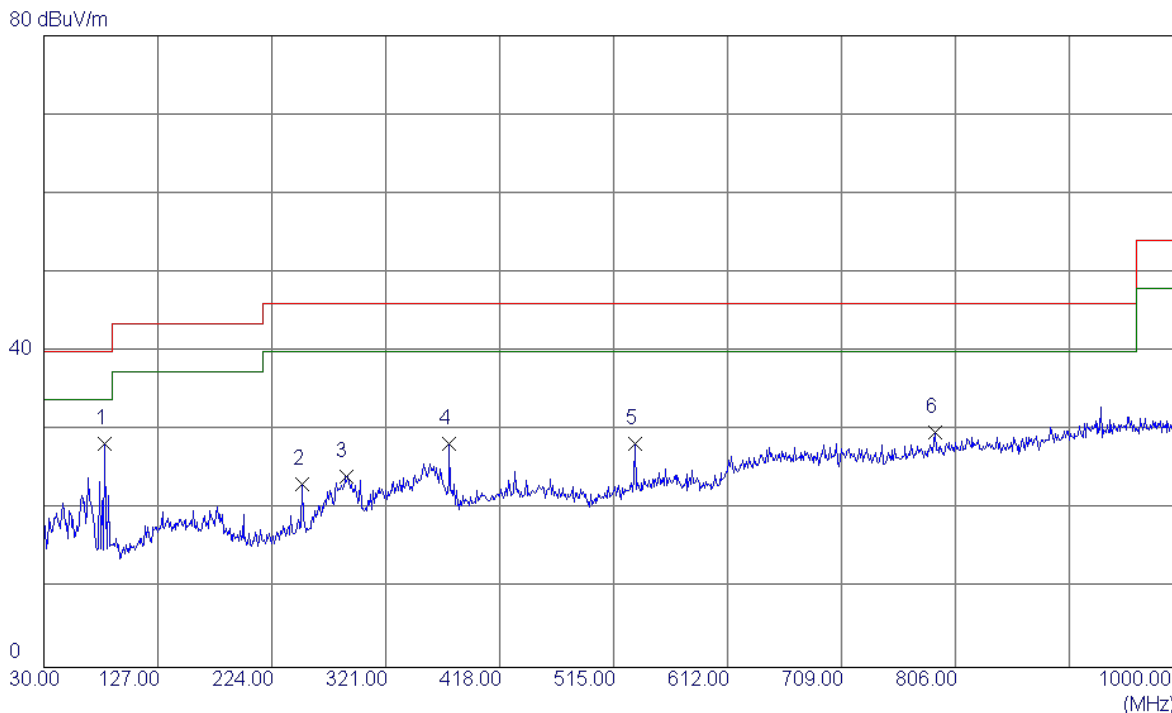

No.	Freq. MHz	Reading Level dBuV/m	Correct Factor dB	Measure ment dBuV/m	Limit dBuV/m	Margin dB	Detector	Comment
1 *	81.4100	44.13	-15.76	28.37	40.00	-11.63	Peak	
2	250.1900	35.86	-12.67	23.19	46.00	-22.81	Peak	
3	287.0500	34.32	-10.19	24.13	46.00	-21.87	Peak	
4	375.3200	36.85	-8.58	28.27	46.00	-17.73	Peak	
5	533.4300	33.86	-5.54	28.32	46.00	-17.68	Peak	
6	788.5400	29.95	-0.20	29.75	46.00	-16.25	Peak	

Test Mode: UNII-3/TX A Mode 5785MHz

Vertical

80 dBuV/m

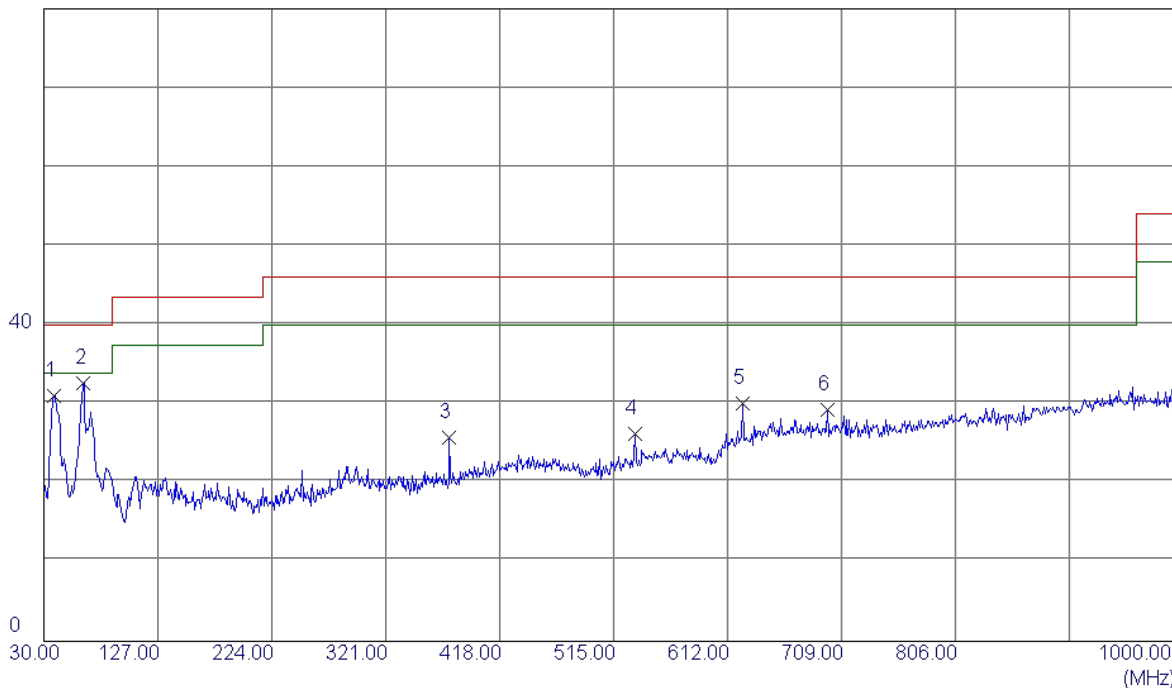

No.	Freq. MHz	Reading Level dBuV/m	Correct Factor dB	Measure ment dBuV/m	Limit dBuV/m	Margin dB	Detector	Comment
1	38.7300	43.91	-12.83	31.08	40.00	-8.92	Peak	
2 *	63.9500	46.55	-13.96	32.59	40.00	-7.41	Peak	
3	375.3200	34.27	-8.58	25.69	46.00	-20.31	Peak	
4	533.4300	31.84	-5.54	26.30	46.00	-19.70	Peak	
5	624.6100	33.24	-3.16	30.08	46.00	-15.92	Peak	
6	697.3600	30.75	-1.48	29.27	46.00	-16.73	Peak	

Test Mode: UNII-3/TX A Mode 5785MHz

Horizontal

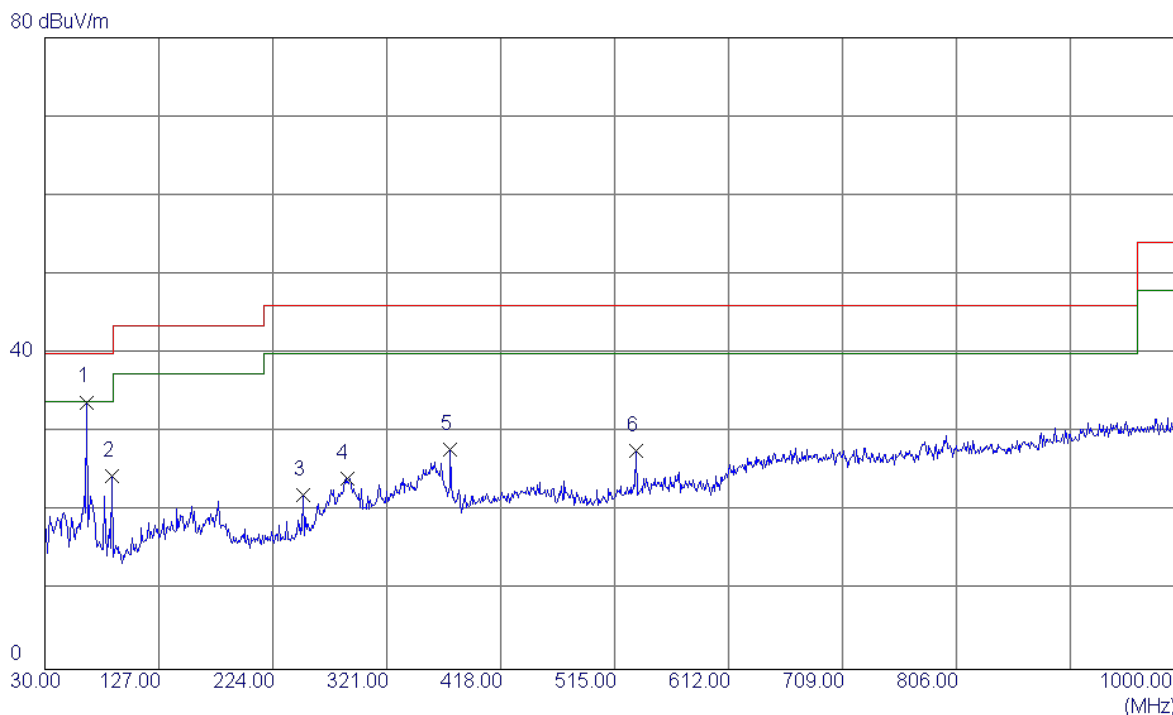

No.	Freq. MHz	Reading Level dBuV/m	Correct Factor dB	Measure ment dBuV/m	Limit dBuV/m	Margin dB	Detector	Comment
1 *	65.8900	48.01	-14.17	33.84	40.00	-6.16	Peak	
2	87.2300	40.43	-15.94	24.49	40.00	-15.51	Peak	
3	250.1900	34.68	-12.67	22.01	46.00	-23.99	Peak	
4	287.0500	34.35	-10.19	24.16	46.00	-21.84	Peak	
5	375.3200	36.38	-8.58	27.80	46.00	-18.20	Peak	
6	533.4300	33.19	-5.54	27.65	46.00	-18.35	Peak	

Test Mode: UNII-3/TX A Mode 5825MHz

Vertical

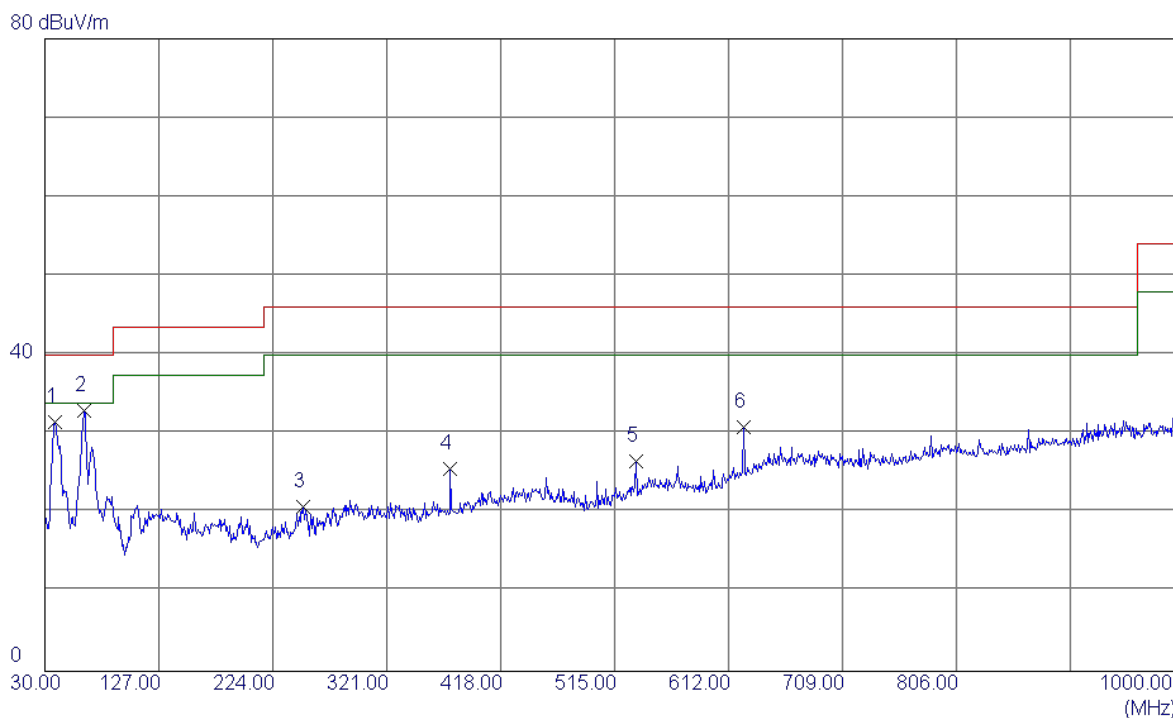

No.	Freq. MHz	Reading Level dBuV/m	Correct Factor dB	Measure ment dBuV/m	Limit dBuV/m	Margin dB	Detector	Comment
1	38.7300	44.37	-12.83	31.54	40.00	-8.46	Peak	
2 *	62.9800	46.88	-13.89	32.99	40.00	-7.01	Peak	
3	250.1900	33.46	-12.67	20.79	46.00	-25.21	Peak	
4	375.3200	34.14	-8.58	25.56	46.00	-20.44	Peak	
5	533.4300	32.10	-5.54	26.56	46.00	-19.44	Peak	
6	624.6100	33.97	-3.16	30.81	46.00	-15.19	Peak	

Test Mode: UNII-3/TX A Mode 5825MHz

Horizontal

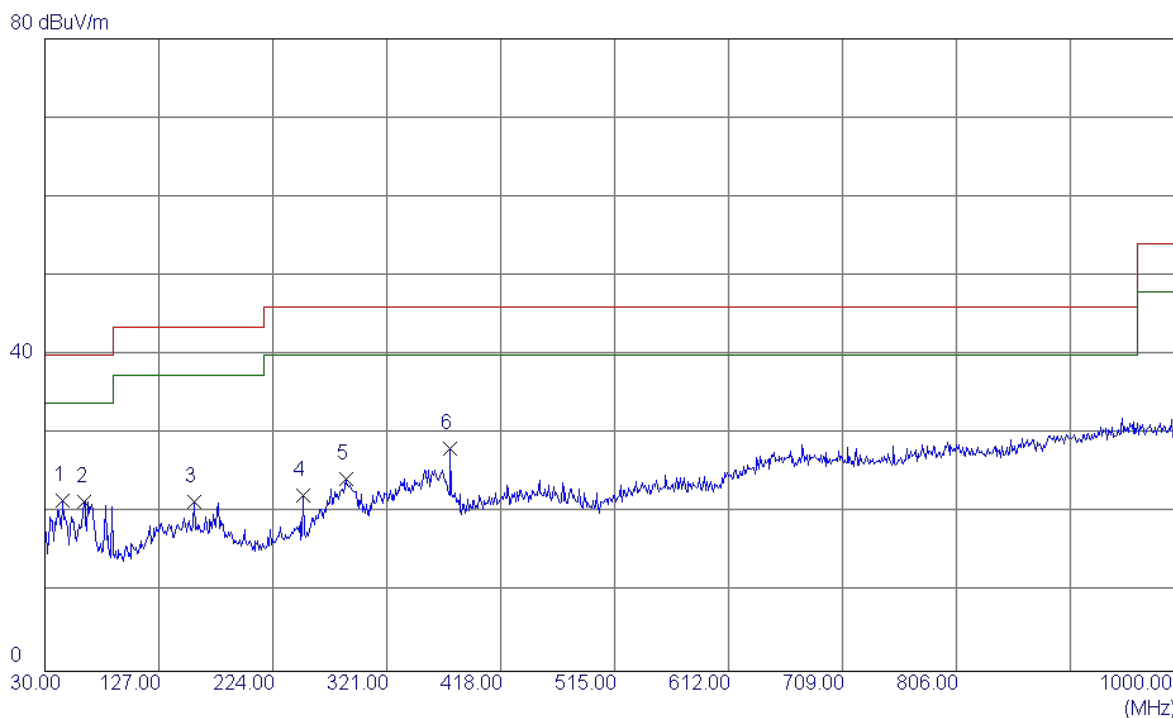

No.	Freq. MHz	Reading Level dBuV/m	Correct Factor dB	Measure ment dBuV/m	Limit dBuV/m	Margin dB	Detector	Comment
1	45.5200	33.45	-11.83	21.62	40.00	-18.38	Peak	
2	63.9500	35.46	-13.96	21.50	40.00	-18.50	Peak	
3	157.0700	33.46	-12.07	21.39	43.50	-22.11	Peak	
4	250.1900	34.93	-12.67	22.26	46.00	-23.74	Peak	
5	286.0799	34.62	-10.31	24.31	46.00	-21.69	Peak	
6 *	375.3200	36.72	-8.58	28.14	46.00	-17.86	Peak	

ATTACHMENT D - RADIATED EMISSION (ABOVE 1000MHZ)

Orthogonal Axis:	X
Test Mode:	UNII-1/ TX A Mode 5180MHz

Vertical

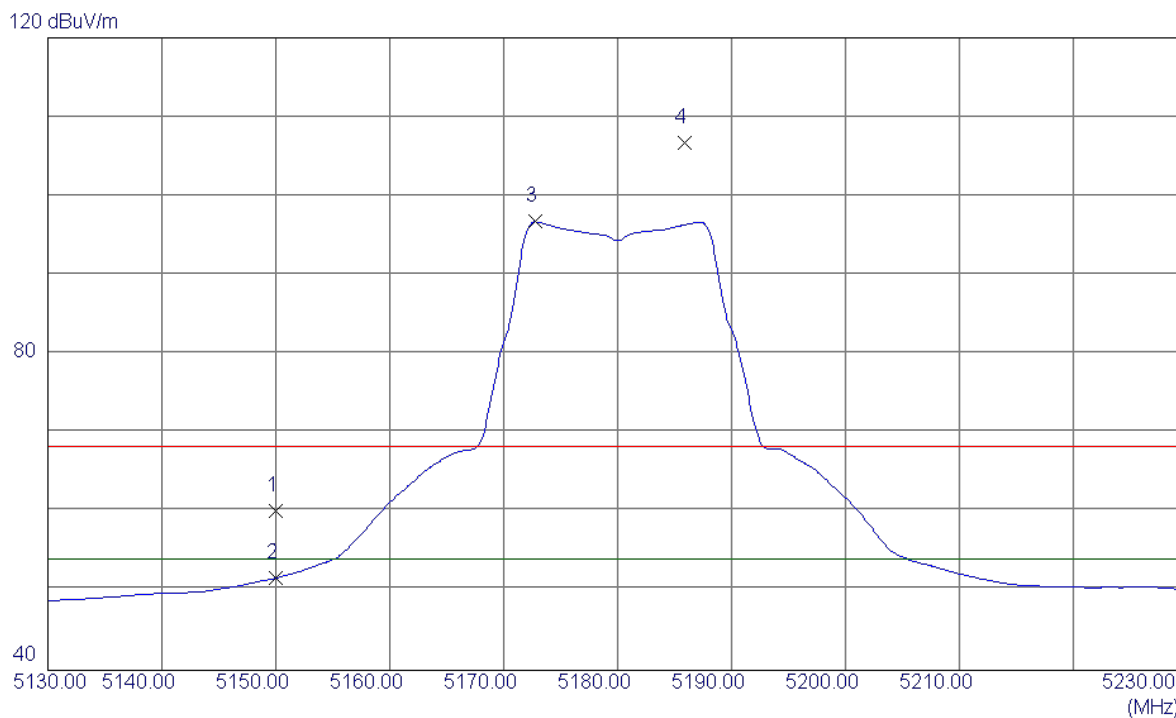

No.	Freq. MHz	Reading Level dBuV/m	Correct Factor dB	Measure ment dBuV/m	Limit dBuV/m	Margin dB	Detector	Comment
1	5150.0000	19.97	40.22	60.19	68.30	-8.11	Peak	
2	5150.0000	11.45	40.22	51.67	54.00	-2.33	AVG	
3 *	5172.8000	56.46	40.27	96.73	54.00	42.73	AVG	No Limit
4	5185.9000	66.40	40.29	106.69	68.30	38.39	Peak	No Limit

Orthogonal Axis:	X
Test Mode:	UNII-1/ TX A Mode 5180MHz

Vertical

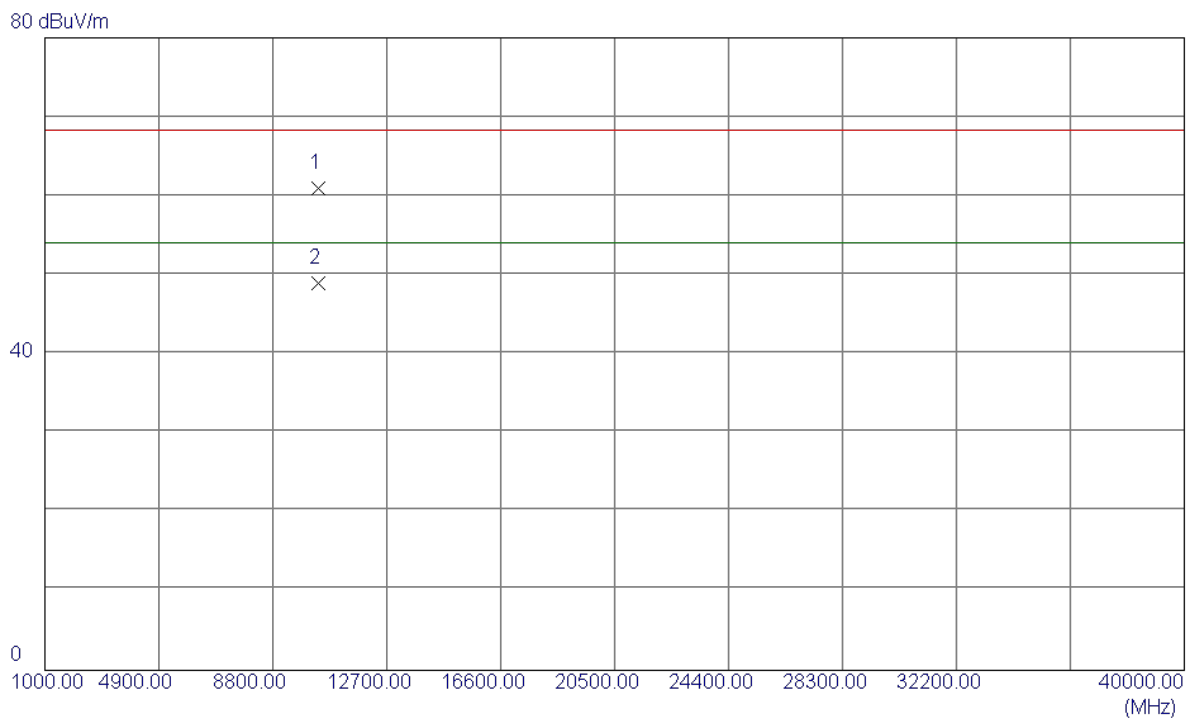

No.	Freq. MHz	Reading Level dBuV/m	Correct Factor dB	Measure ment dBuV/m	Limit dBuV/m	Margin dB	Detector	Comment
1	10359.4000	47.08	13.86	60.94	68.30	-7.36	Peak	
2 *	10360.8000	35.13	13.86	48.99	54.00	-5.01	AVG	

Orthogonal Axis:	X
Test Mode:	UNII-1/ TX A Mode 5180MHz

Horizontal

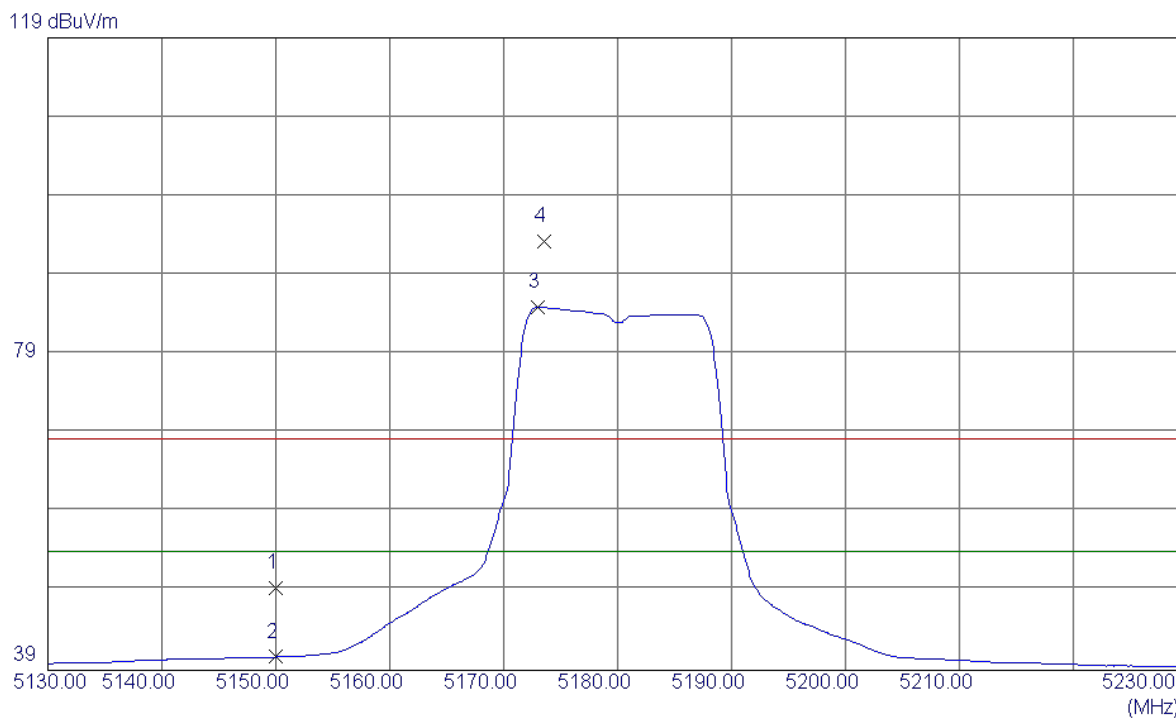

No.	Freq. MHz	Reading Level dBuV/m	Correct Factor dB	Measure ment dBuV/m	Limit dBuV/m	Margin dB	Detector	Comment
1	5150.0000	9.12	40.22	49.34	68.30	-18.96	Peak	
2	5150.0000	0.46	40.22	40.68	54.00	-13.32	AVG	
3 *	5173.0000	44.64	40.27	84.91	54.00	30.91	AVG	No Limit
4	5173.6000	53.01	40.27	93.28	68.30	24.98	Peak	No Limit

Orthogonal Axis:	X
Test Mode:	UNII-1/ TX A Mode 5180MHz

Horizontal

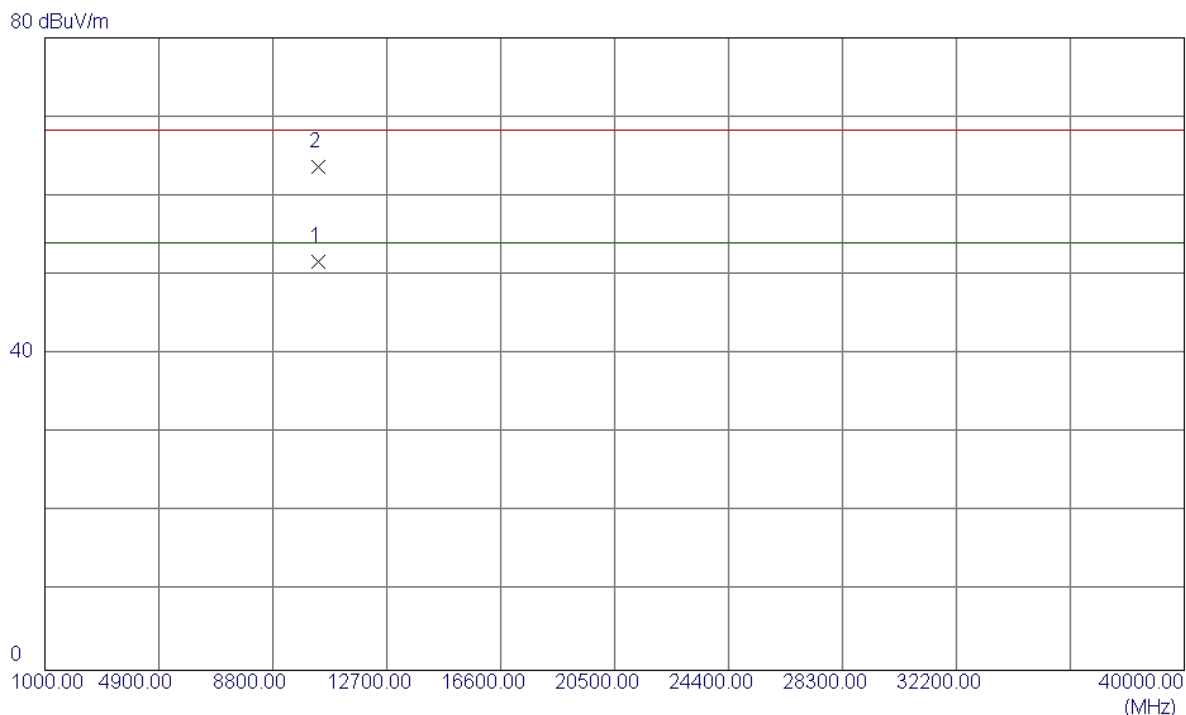

No.	Freq. MHz	Reading Level dBuV/m	Correct Factor dB	Measure ment dBuV/m	Limit dBuV/m	Margin dB	Detector	Comment
1 *	10361.0000	37.88	13.86	51.74	54.00	-2.26	AVG	
2	10364.0000	49.85	13.85	63.70	68.30	-4.60	Peak	

Orthogonal Axis:	X
Test Mode:	UNII-1/ TX A Mode 5200MHz

Vertical

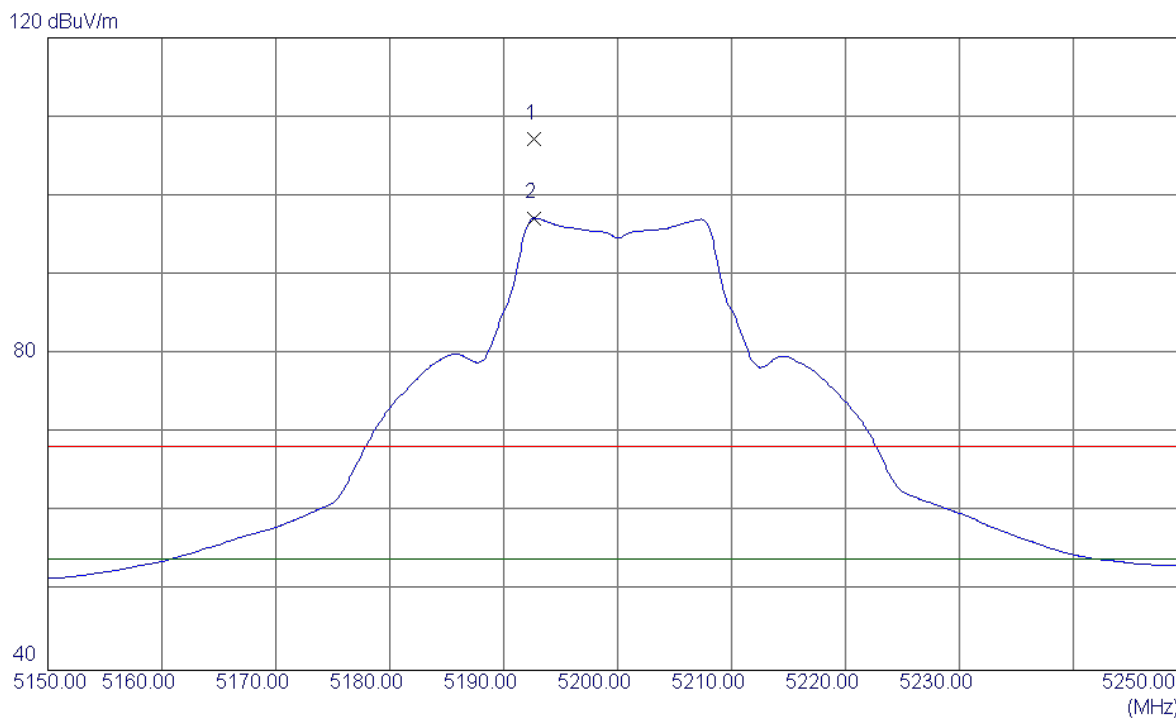

No.	Freq. MHz	Reading Level dBuV/m	Correct Factor dB	Measure ment dBuV/m	Limit dBuV/m	Margin dB	Detector	Comment
1	5192.7000	66.91	40.31	107.22	68.30	38.92	Peak	No Limit
2 *	5192.7000	56.89	40.31	97.20	54.00	43.20	AVG	No Limit

Orthogonal Axis:	X
Test Mode:	UNII-1/ TX A Mode 5200MHz

Vertical

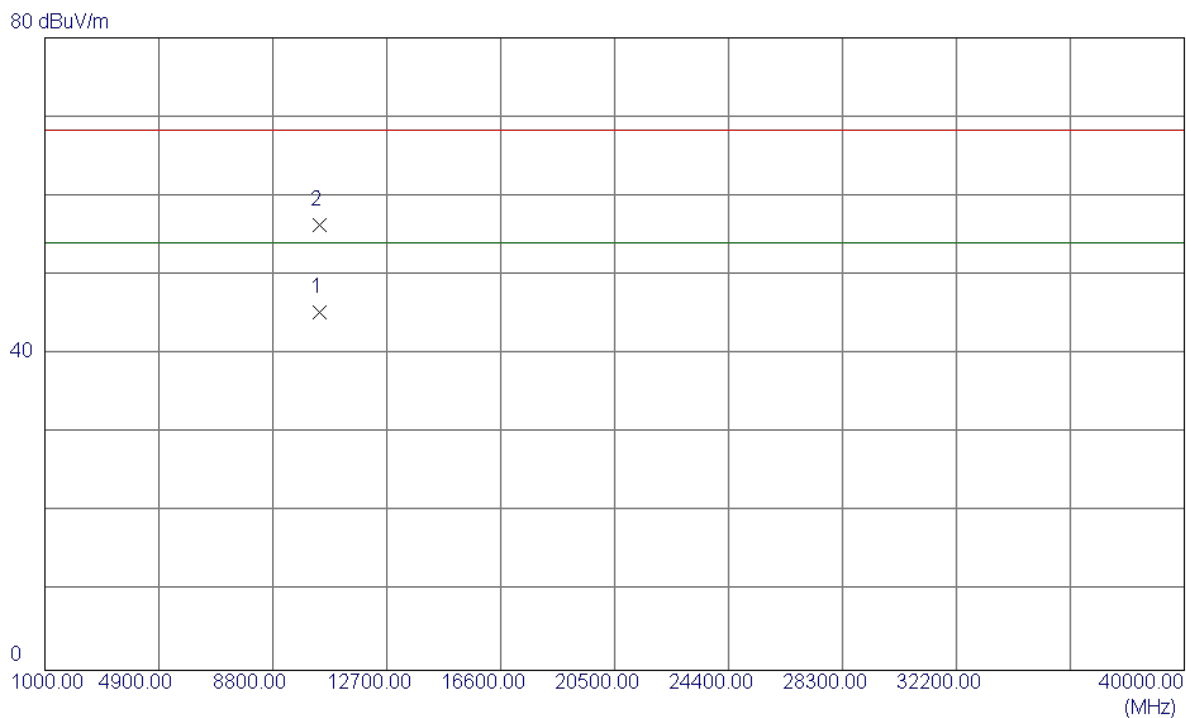

No.	Freq. MHz	Reading Level dBuV/m	Correct Factor dB	Measure ment dBuV/m	Limit dBuV/m	Margin dB	Detector	Comment
1 *	10400.0000	31.41	13.80	45.21	54.00	-8.79	AVG	
2	10396.4000	42.46	13.81	56.27	68.30	-12.03	Peak	

Orthogonal Axis:	X
Test Mode:	UNII-1/ TX A Mode 5200MHz

Horizontal

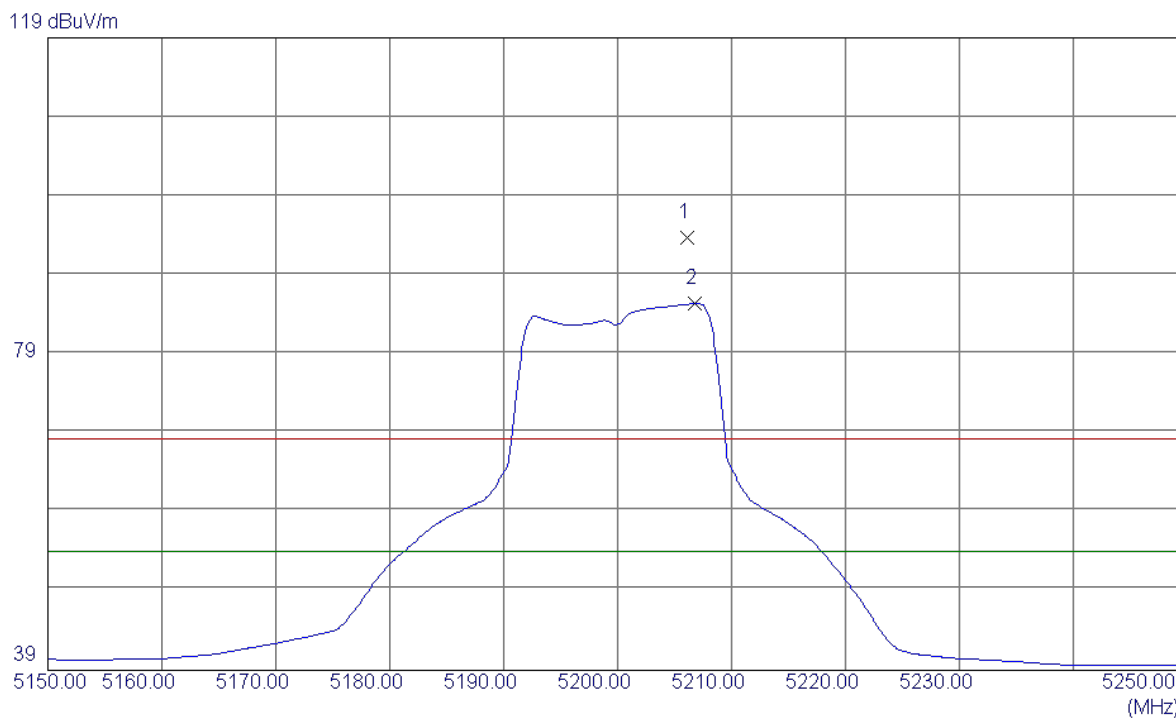

No.	Freq. MHz	Reading Level dBuV/m	Correct Factor dB	Measure ment dBuV/m	Limit dBuV/m	Margin dB	Detector	Comment
1	5206.1000	53.33	40.34	93.67	68.30	25.37	Peak	No Limit
2 *	5206.8000	45.04	40.34	85.38	54.00	31.38	AVG	No Limit

Orthogonal Axis:	X
Test Mode:	UNII-1/ TX A Mode 5200MHz

Horizontal

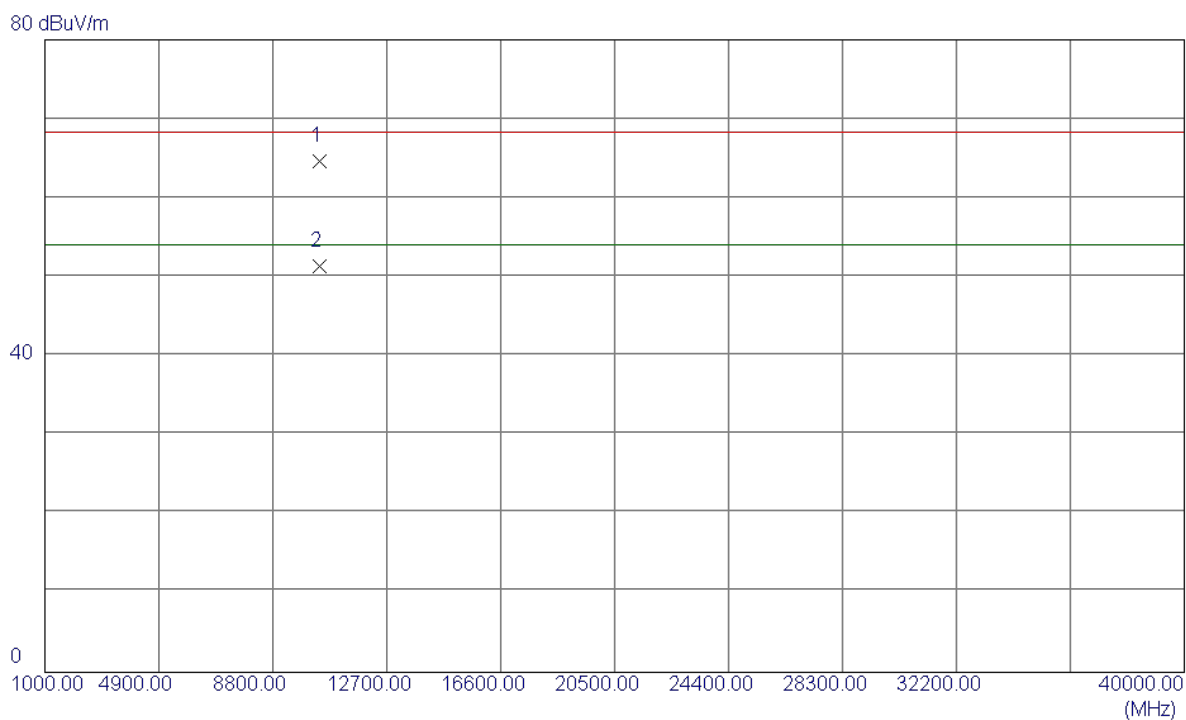

No.	Freq. MHz	Reading Level dBuV/m	Correct Factor dB	Measure ment dBuV/m	Limit dBuV/m	Margin dB	Detector	Comment
1	10399.0000	50.86	13.80	64.66	68.30	-3.64	Peak	
2 *	10400.8000	37.53	13.80	51.33	54.00	-2.67	AVG	

Orthogonal Axis:	X
Test Mode:	UNII-1/ TX A Mode 5240MHz

Vertical

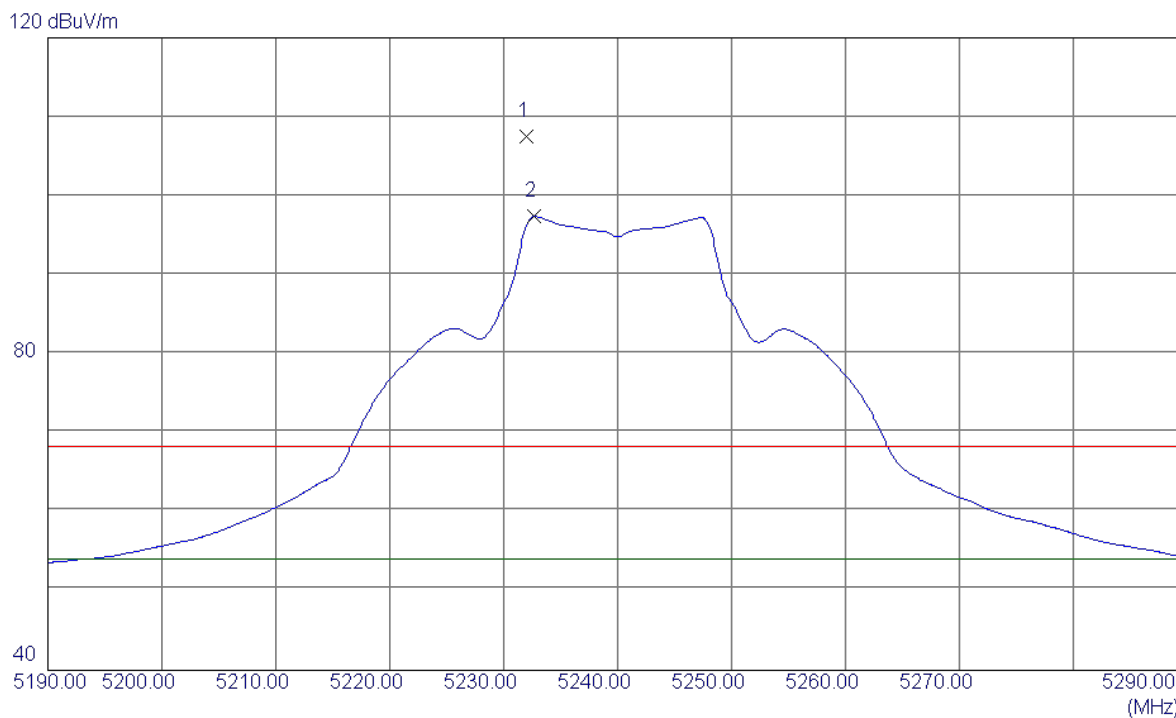

No.	Freq. MHz	Reading Level dBuV/m	Correct Factor dB	Measure ment dBuV/m	Limit dBuV/m	Margin dB	Detector	Comment
1	5232.0000	67.21	40.39	107.60	68.30	39.30	Peak	No Limit
2 *	5232.7000	57.02	40.39	97.41	54.00	43.41	AVG	No Limit

Orthogonal Axis:	X
Test Mode:	UNII-1/ TX A Mode 5240MHz

Vertical

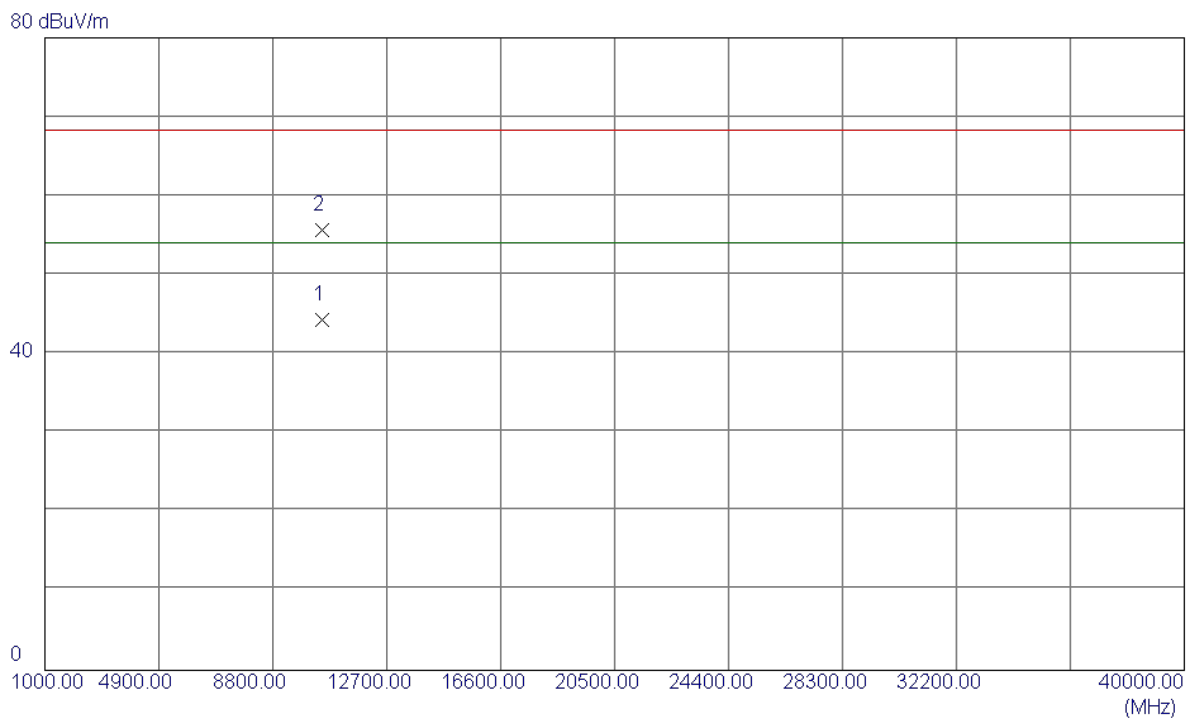

No.	Freq. MHz	Reading Level dBuV/m	Correct Factor dB	Measure ment dBuV/m	Limit dBuV/m	Margin dB	Detector	Comment
1 *	10480.0000	30.64	13.69	44.33	54.00	-9.67	AVG	
2	10483.2000	41.99	13.69	55.68	68.30	-12.62	Peak	

Orthogonal Axis:	X
Test Mode:	UNII-1/ TX A Mode 5240MHz

Horizontal

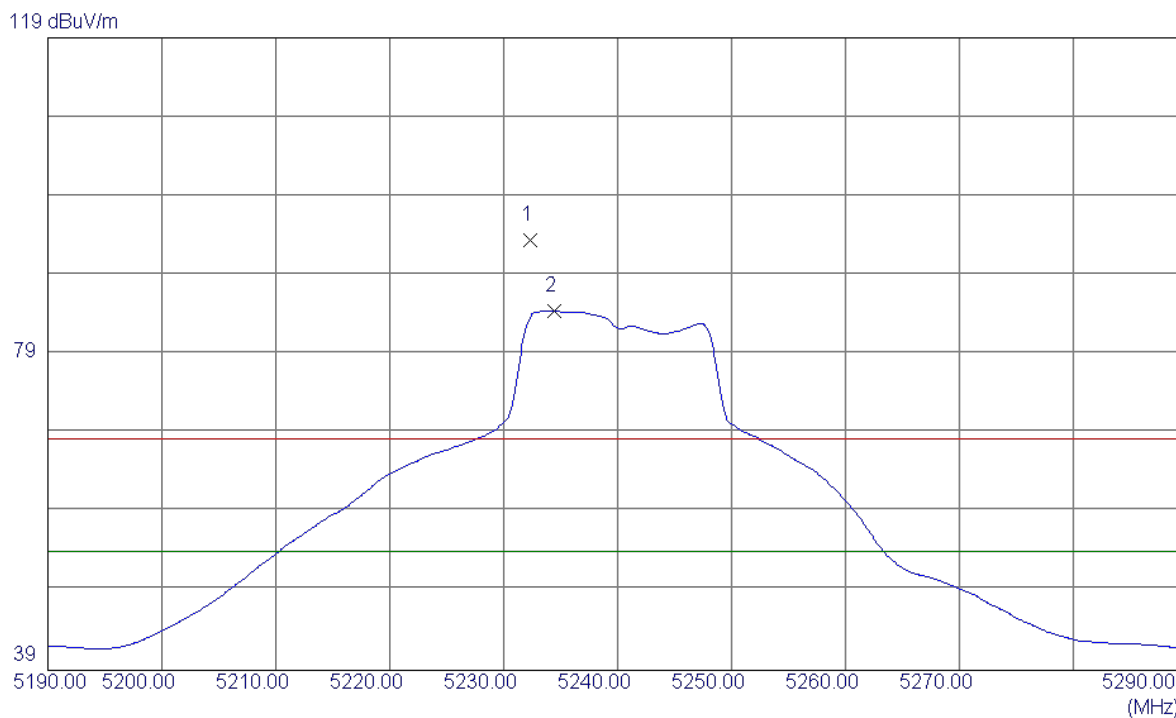

No.	Freq. MHz	Reading Level dBuV/m	Correct Factor dB	Measure ment dBuV/m	Limit dBuV/m	Margin dB	Detector	Comment
1	5232.3000	52.99	40.39	93.38	68.30	25.08	Peak	No Limit
2 *	5234.4000	44.01	40.40	84.41	54.00	30.41	AVG	No Limit

Orthogonal Axis:	X
Test Mode:	UNII-1/ TX A Mode 5240MHz

Horizontal

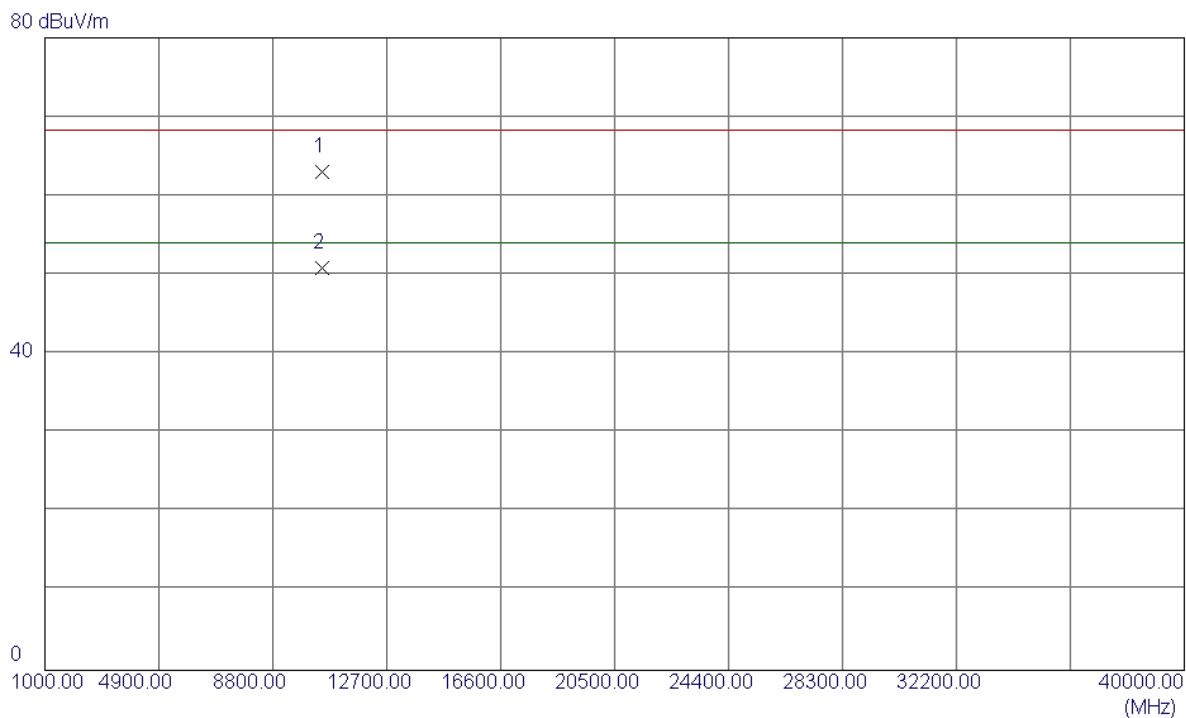

No.	Freq. MHz	Reading Level dBuV/m	Correct Factor dB	Measure ment dBuV/m	Limit dBuV/m	Margin dB	Detector	Comment
1	10478.2000	49.36	13.69	63.05	68.30	-5.25	Peak	
2 *	10481.4000	37.25	13.69	50.94	54.00	-3.06	AVG	

Orthogonal Axis:	X
Test Mode:	UNII-1/ TX N20 Mode 5180MHz

Vertical

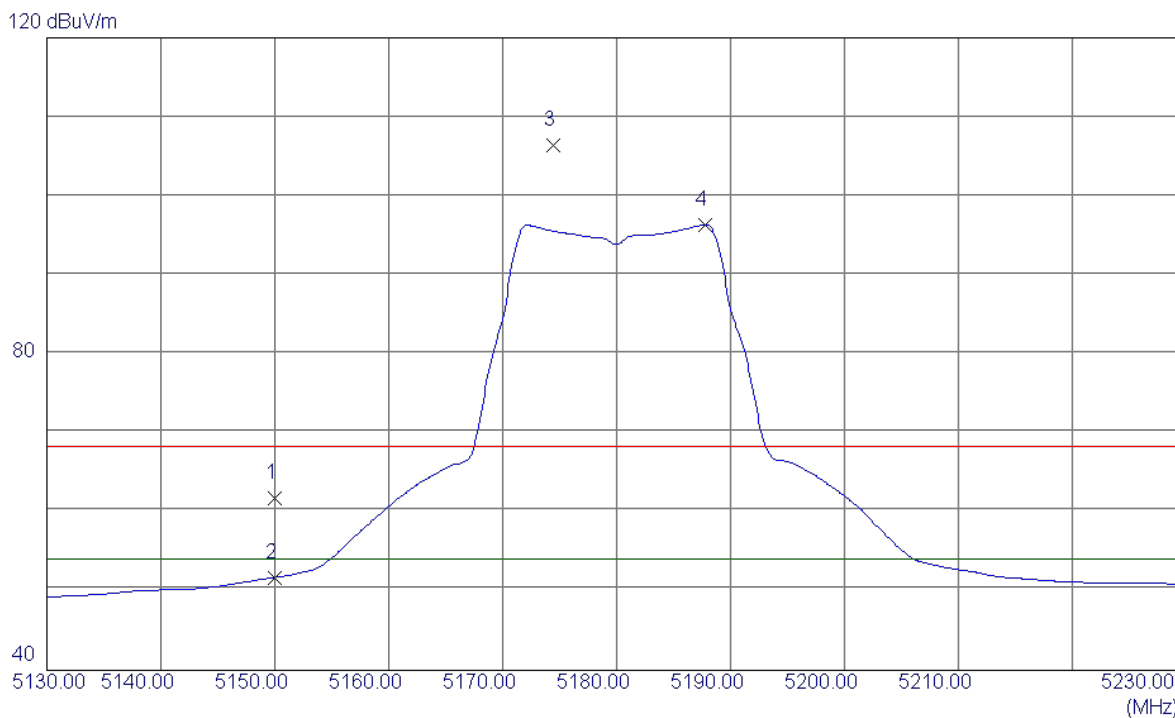

No.	Freq. MHz	Reading Level dBuV/m	Correct Factor dB	Measure ment dBuV/m	Limit dBuV/m	Margin dB	Detector	Comment
1	5150.0000	21.51	40.22	61.73	68.30	-6.57	Peak	
2	5150.0000	11.52	40.22	51.74	54.00	-2.26	AVG	
3	5174.4000	66.18	40.27	106.45	68.30	38.15	Peak	No Limit
4 *	5187.8000	56.03	40.30	96.33	54.00	42.33	AVG	No Limit

Orthogonal Axis:	X
Test Mode:	UNII-1/ TX N20 Mode 5180MHz

Vertical

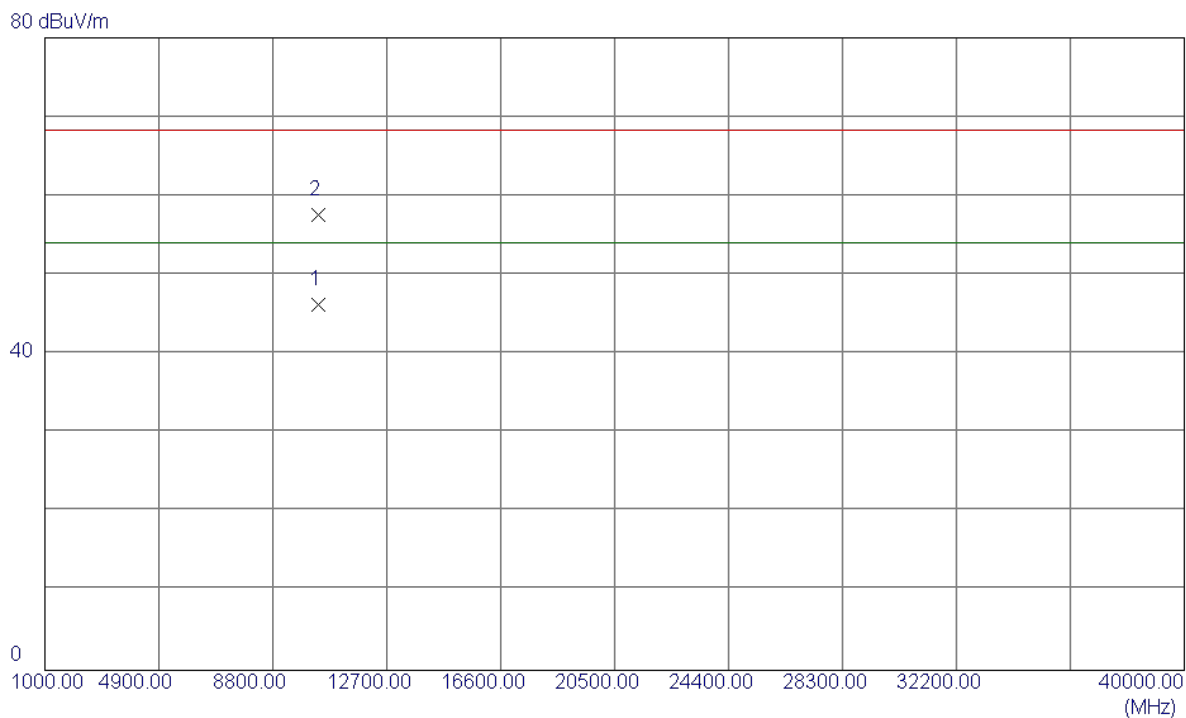

No.	Freq. MHz	Reading Level dBuV/m	Correct Factor dB	Measure ment dBuV/m	Limit dBuV/m	Margin dB	Detector	Comment
1 *	10359.6000	32.31	13.86	46.17	54.00	-7.83	AVG	
2	10358.4000	43.68	13.86	57.54	68.30	-10.76	Peak	

Orthogonal Axis:	X
Test Mode:	UNII-1/ TX N20 Mode 5180MHz

Horizontal

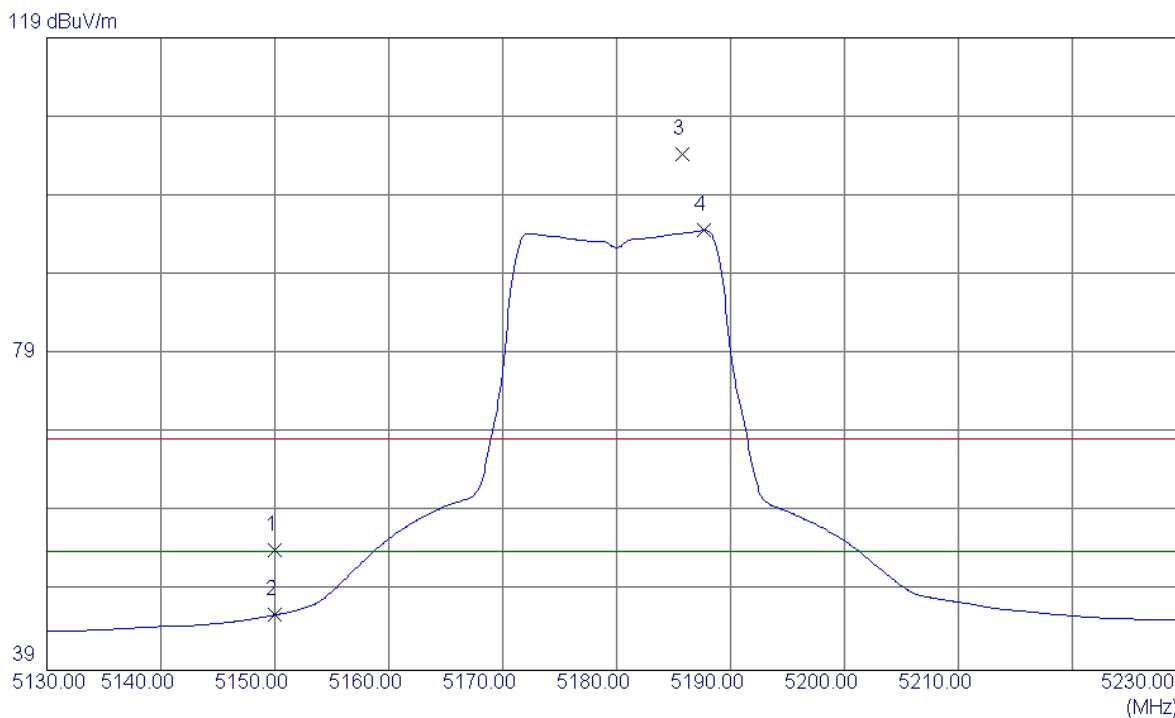

No.	Freq. MHz	Reading Level dBuV/m	Correct Factor dB	Measure ment dBuV/m	Limit dBuV/m	Margin dB	Detector	Comment
1	5150.0000	14.00	40.22	54.22	68.30	-14.08	Peak	
2	5150.0000	5.77	40.22	45.99	54.00	-8.01	AVG	
3	5185.8000	63.95	40.29	104.24	68.30	35.94	Peak	No Limit
4 *	5187.7000	54.35	40.30	94.65	54.00	40.65	AVG	No Limit

Orthogonal Axis:	X
Test Mode:	UNII-1/ TX N20 Mode 5180MHz

Horizontal

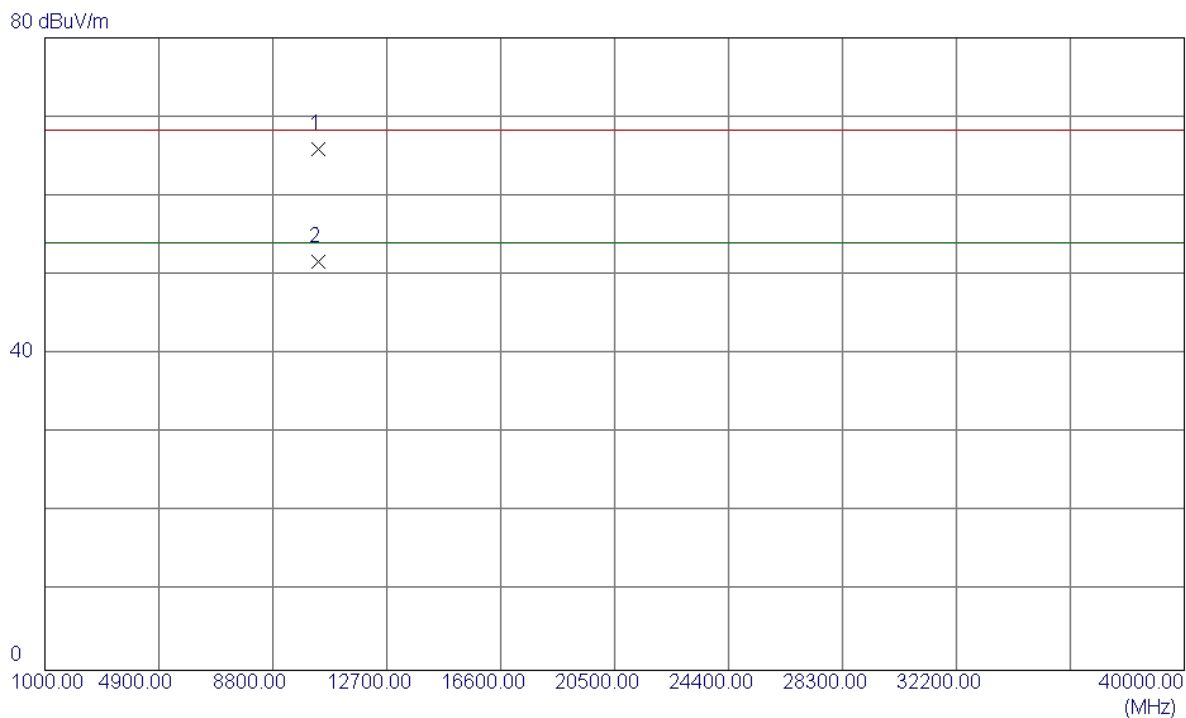

No.	Freq. MHz	Reading Level dBuV/m	Correct Factor dB	Measure ment dBuV/m	Limit dBuV/m	Margin dB	Detector	Comment
1	10357.6000	52.06	13.86	65.92	68.30	-2.38	Peak	
2 *	10360.4000	37.87	13.86	51.73	54.00	-2.27	AVG	

Orthogonal Axis:	X
Test Mode:	UNII-1/ TX N20 Mode 5200MHz

Vertical

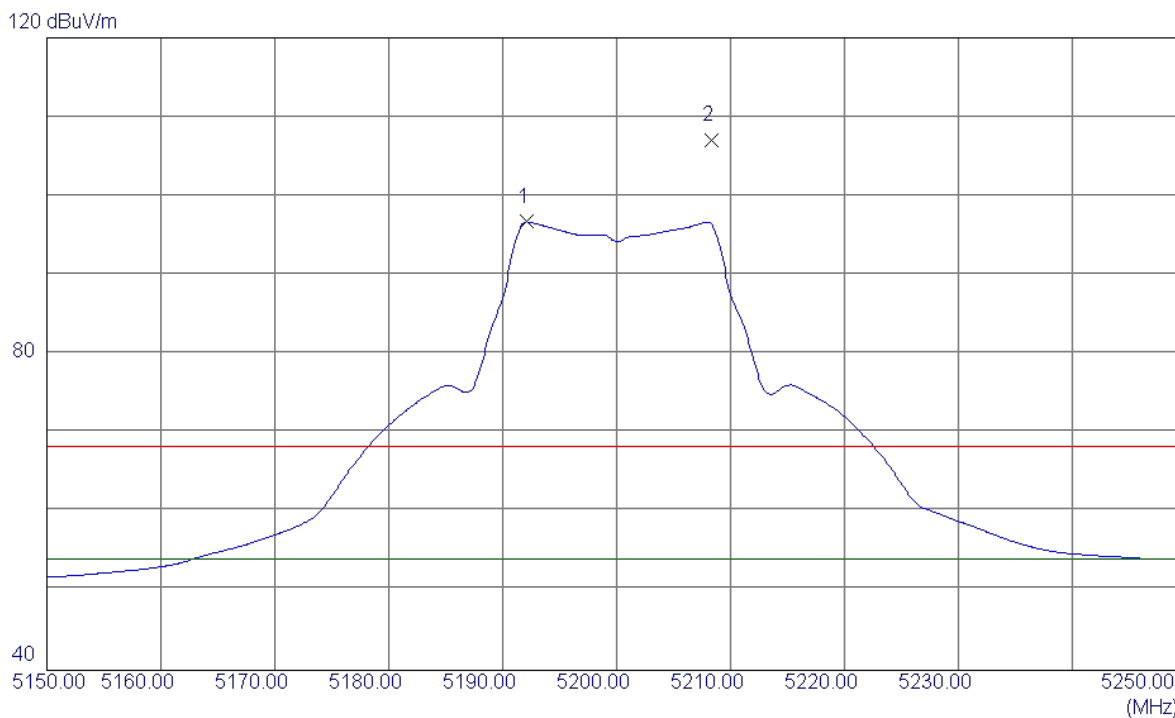

No.	Freq. MHz	Reading Level dBuV/m	Correct Factor dB	Measure ment dBuV/m	Limit dBuV/m	Margin dB	Detector	Comment
1 *	5192.1000	56.41	40.31	96.72	54.00	42.72	AVG	No Limit
2	5208.3000	66.73	40.34	107.07	68.30	38.77	Peak	No Limit

Orthogonal Axis:	X
Test Mode:	UNII-1/ TX N20 Mode 5200MHz

Vertical

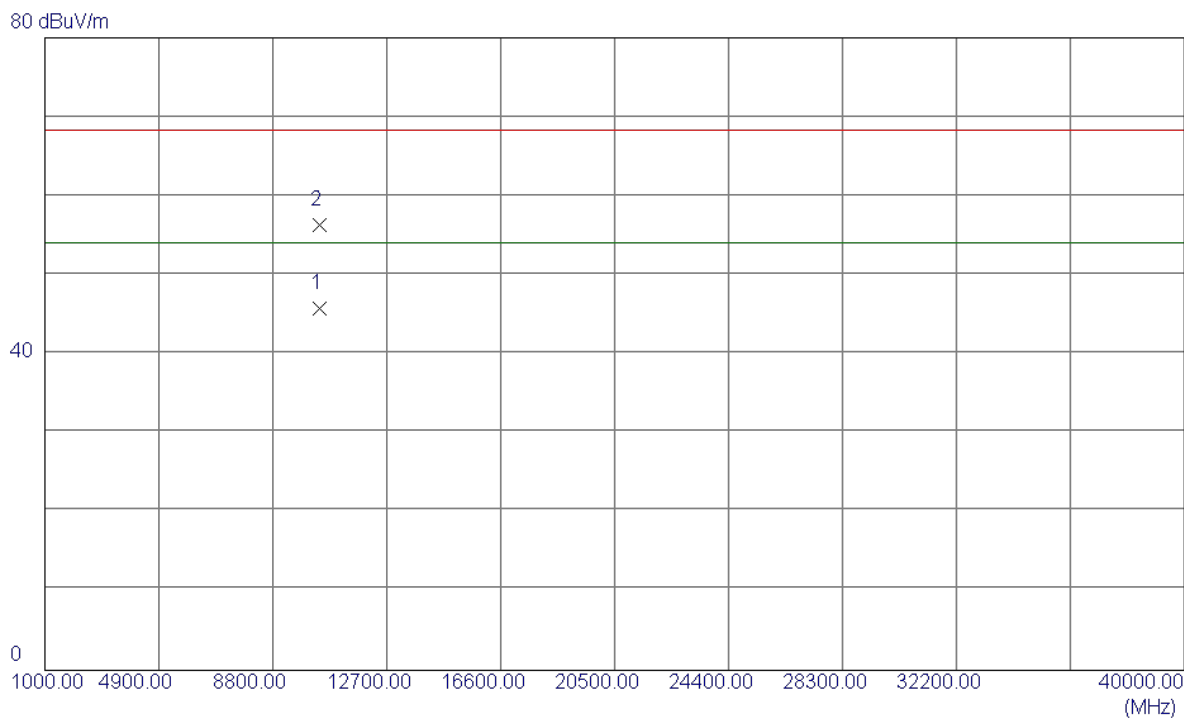

No.	Freq. MHz	Reading Level dBuV/m	Correct Factor dB	Measure ment dBuV/m	Limit dBuV/m	Margin dB	Detector	Comment
1 *	10399.6000	31.95	13.80	45.75	54.00	-8.25	AVG	
2	10401.2000	42.51	13.80	56.31	68.30	-11.99	Peak	

Orthogonal Axis:	X
Test Mode:	UNII-1/ TX N20 Mode 5200MHz

Horizontal

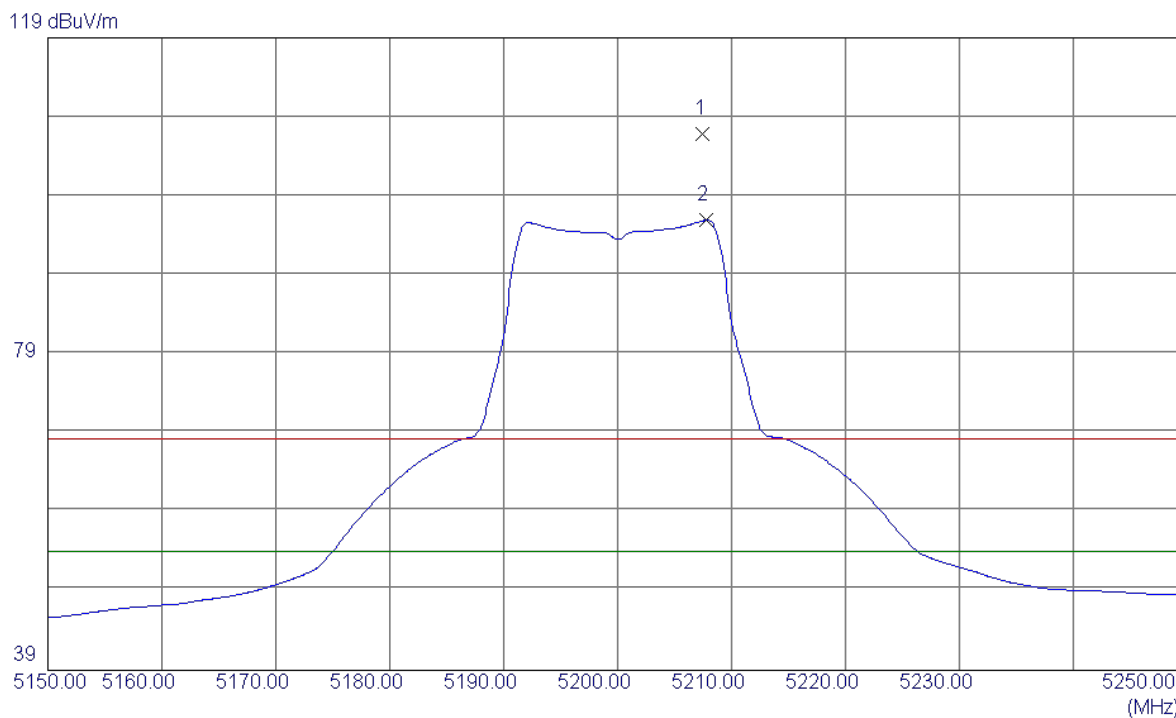

No.	Freq. MHz	Reading Level dBuV/m	Correct Factor dB	Measure ment dBuV/m	Limit dBuV/m	Margin dB	Detector	Comment
1	5207.5000	66.44	40.34	106.78	68.30	38.48	Peak	No Limit
2 *	5207.8000	55.59	40.34	95.93	54.00	41.93	AVG	No Limit

Orthogonal Axis:	X
Test Mode:	UNII-1/ TX N20 Mode 5200MHz

Horizontal

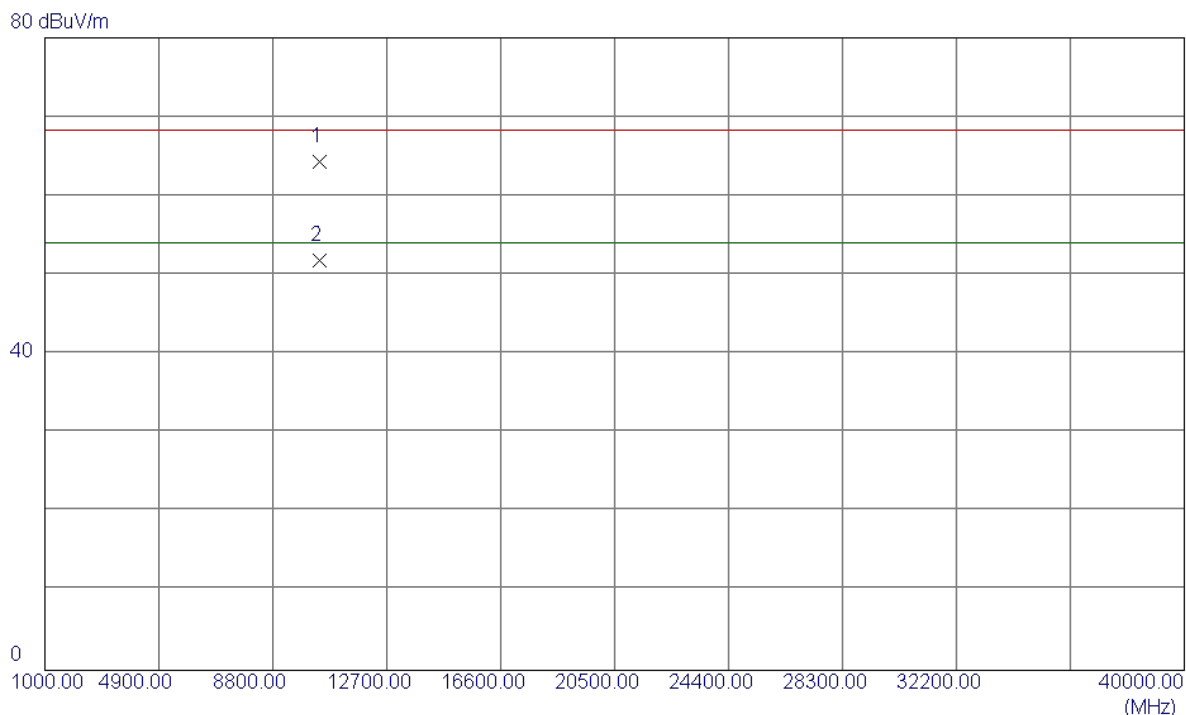

No.	Freq. MHz	Reading Level dBuV/m	Correct Factor dB	Measure ment dBuV/m	Limit dBuV/m	Margin dB	Detector	Comment
1	10399.8000	50.54	13.80	64.34	68.30	-3.96	Peak	
2 *	10400.2000	38.08	13.80	51.88	54.00	-2.12	AVG	

Orthogonal Axis:	X
Test Mode:	UNII-1/ TX N20 Mode 5240MHz

Vertical

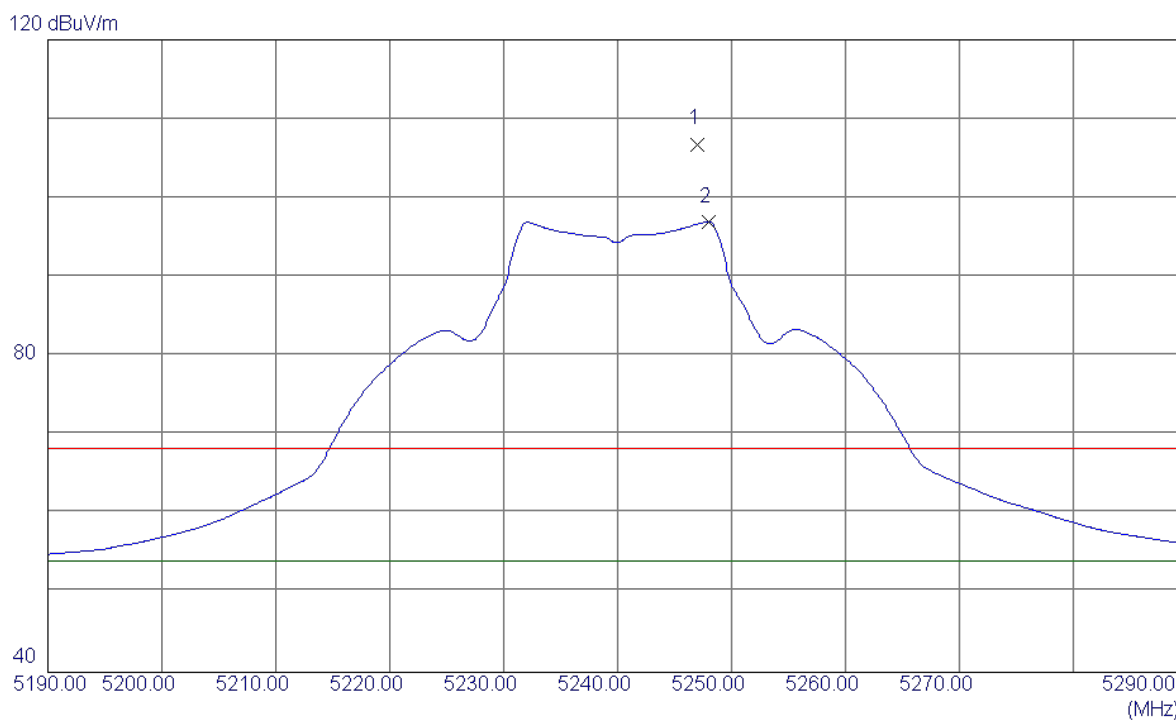

No.	Freq. MHz	Reading Level dBuV/m	Correct Factor dB	Measure ment dBuV/m	Limit dBuV/m	Margin dB	Detector	Comment
1	5247.0000	66.38	40.42	106.80	68.30	38.50	Peak	No Limit
2 *	5248.0000	56.55	40.43	96.98	54.00	42.98	AVG	No Limit

Orthogonal Axis:	X
Test Mode:	UNII-1/ TX N20 Mode 5240MHz

Vertical

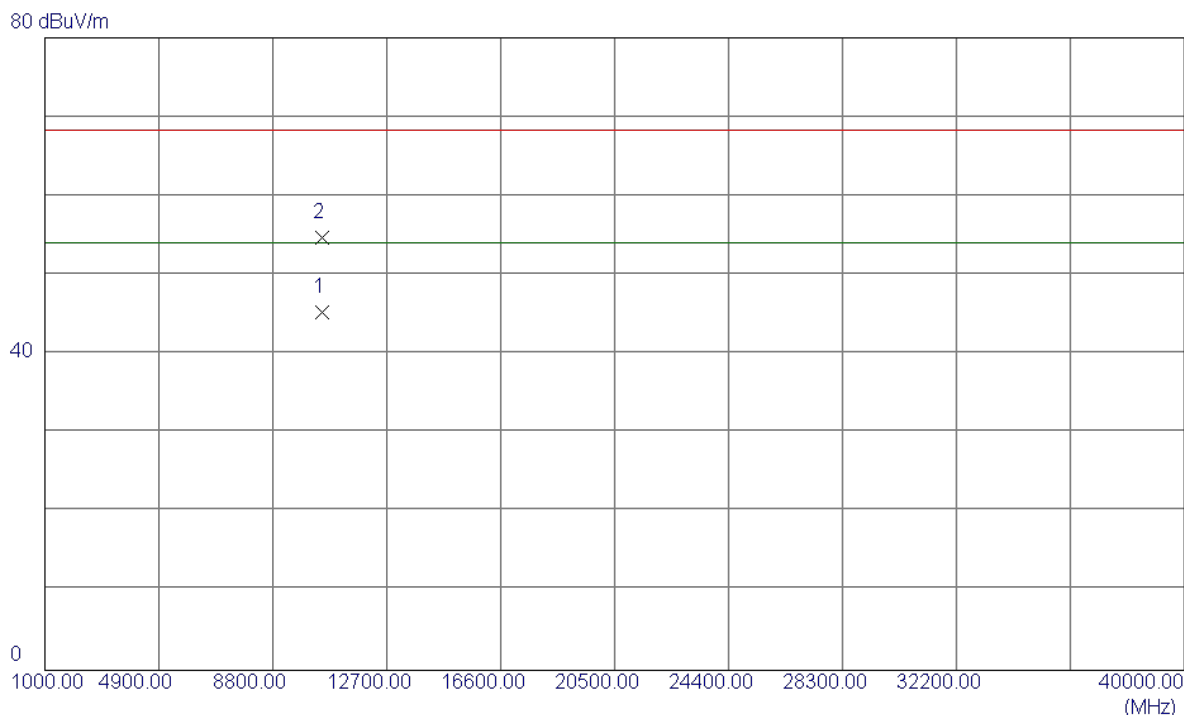

No.	Freq. MHz	Reading Level dBuV/m	Correct Factor dB	Measure ment dBuV/m	Limit dBuV/m	Margin dB	Detector	Comment
1 *	10479.2000	31.53	13.69	45.22	54.00	-8.78	AVG	
2	10484.4000	41.09	13.69	54.78	68.30	-13.52	Peak	

Orthogonal Axis:	X
Test Mode:	UNII-1/ TX N20 Mode 5240MHz

Horizontal

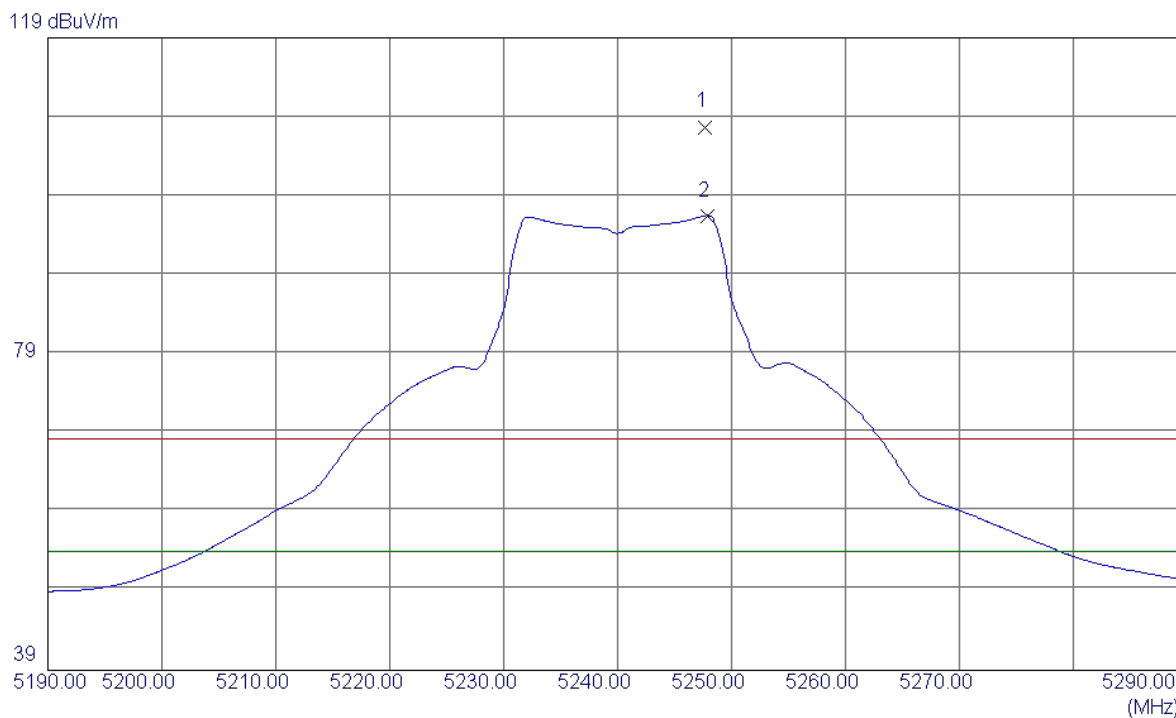

No.	Freq. MHz	Reading Level dBuV/m	Correct Factor dB	Measure ment dBuV/m	Limit dBuV/m	Margin dB	Detector	Comment
1	5247.7000	67.29	40.43	107.72	68.30	39.42	Peak	No Limit
2 *	5247.9000	56.09	40.43	96.52	54.00	42.52	AVG	No Limit

Orthogonal Axis:	X
Test Mode:	UNII-1/ TX N20 Mode 5240MHz

Horizontal

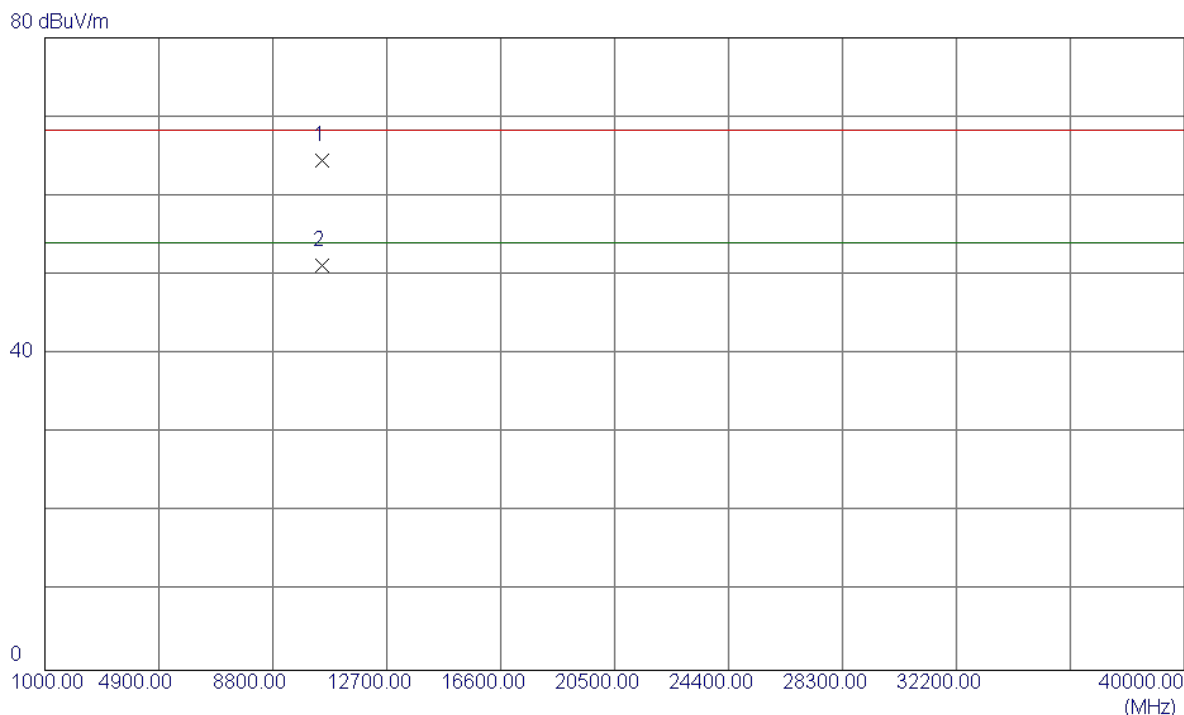

No.	Freq. MHz	Reading Level dBuV/m	Correct Factor dB	Measure ment dBuV/m	Limit dBuV/m	Margin dB	Detector	Comment
1	10476.4000	50.84	13.70	64.54	68.30	-3.76	Peak	
2 *	10480.4000	37.56	13.69	51.25	54.00	-2.75	AVG	

Orthogonal Axis:	X
Test Mode:	UNII-1/ TX N40 Mode 5190MHz

Vertical

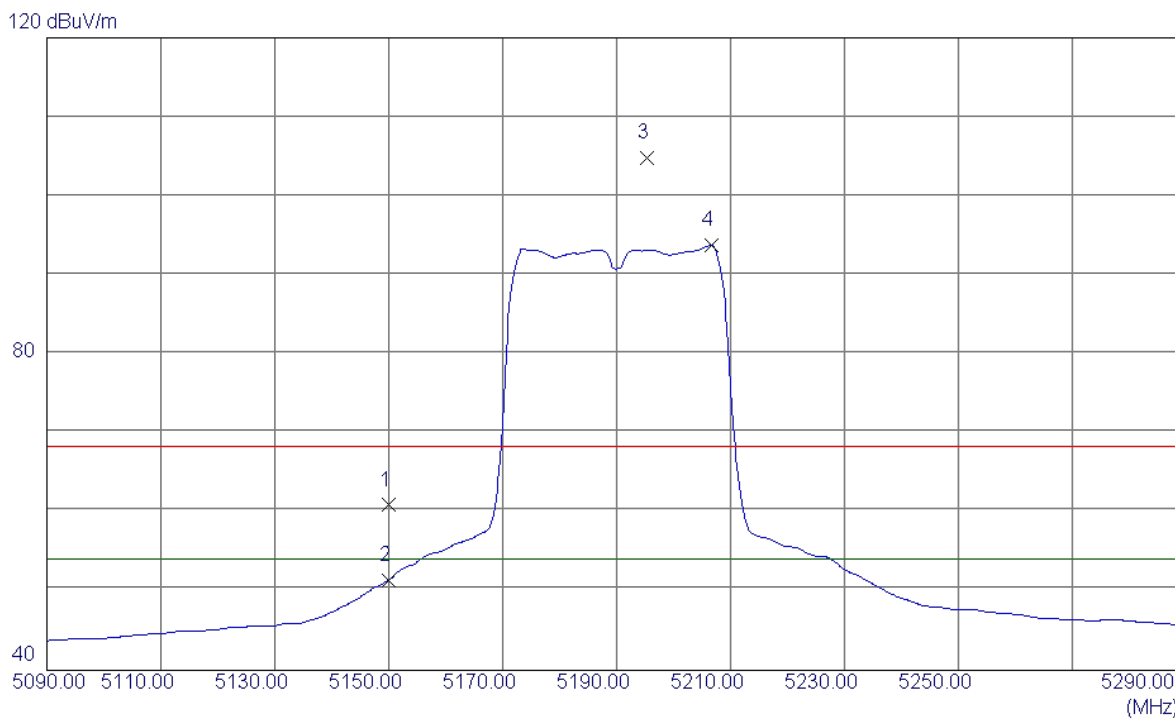

No.	Freq. MHz	Reading Level dBuV/m	Correct Factor dB	Measure ment dBuV/m	Limit dBuV/m	Margin dB	Detector	Comment
1	5150.0000	20.66	40.22	60.88	68.30	-7.42	Peak	
2	5150.0000	11.18	40.22	51.40	54.00	-2.60	AVG	
3	5195.4000	64.55	40.31	104.86	68.30	36.56	Peak	No Limit
4 *	5206.6000	53.49	40.34	93.83	54.00	39.83	AVG	No Limit

Orthogonal Axis:	X
Test Mode:	UNII-1/ TX N40 Mode 5190MHz

Vertical

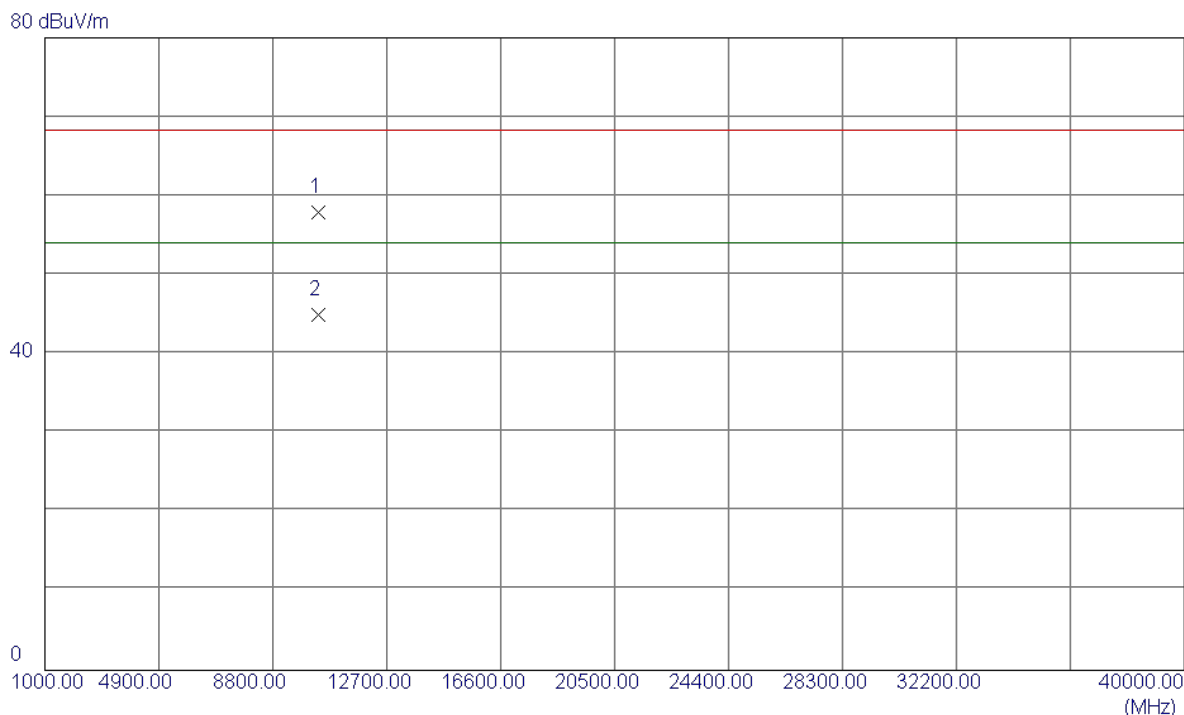

No.	Freq. MHz	Reading Level dBuV/m	Correct Factor dB	Measure ment dBuV/m	Limit dBuV/m	Margin dB	Detector	Comment
1	10380.0000	44.16	13.83	57.99	68.30	-10.31	Peak	
2 *	10381.2000	31.18	13.83	45.01	54.00	-8.99	AVG	

Orthogonal Axis:	X
Test Mode:	UNII-1/ TX N40 Mode 5190MHz

Horizontal

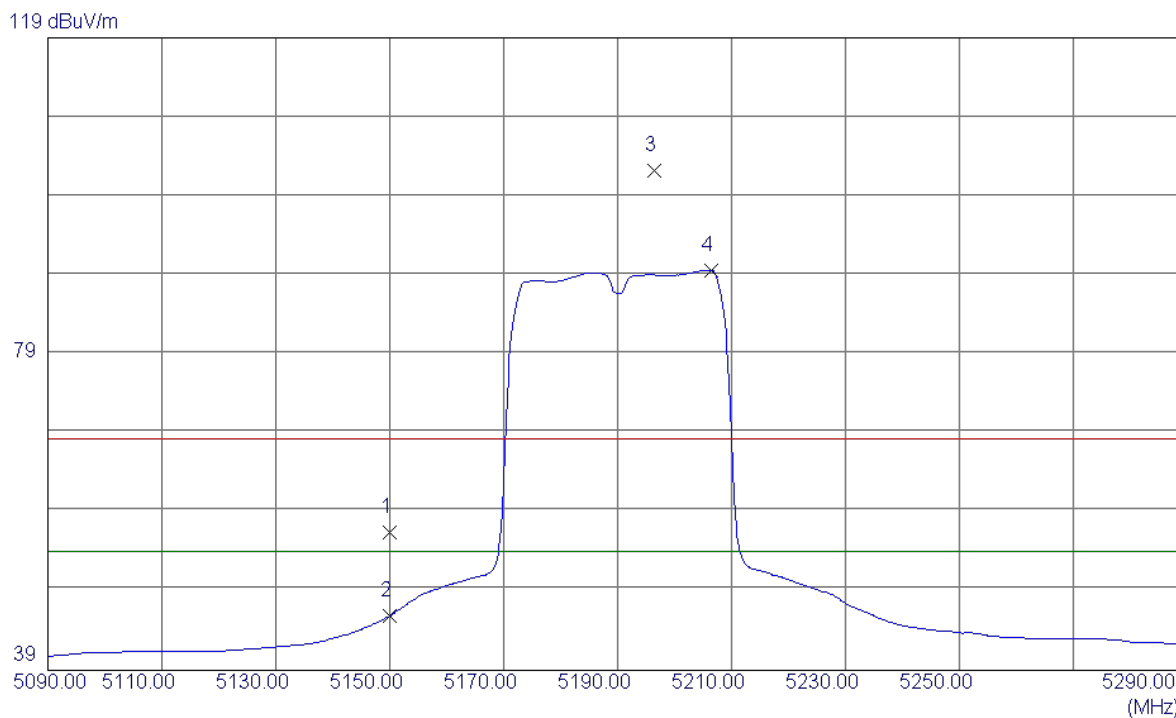

No.	Freq. MHz	Reading Level dBuV/m	Correct Factor dB	Measure ment dBuV/m	Limit dBuV/m	Margin dB	Detector	Comment
1	5150.0000	16.29	40.22	56.51	68.30	-11.79	Peak	
2	5150.0000	5.65	40.22	45.87	54.00	-8.13	AVG	
3	5196.4000	61.88	40.32	102.20	68.30	33.90	Peak	No Limit
4 *	5206.4000	49.24	40.34	89.58	54.00	35.58	AVG	No Limit

Orthogonal Axis:	X
Test Mode:	UNII-1/ TX N40 Mode 5190MHz

Horizontal

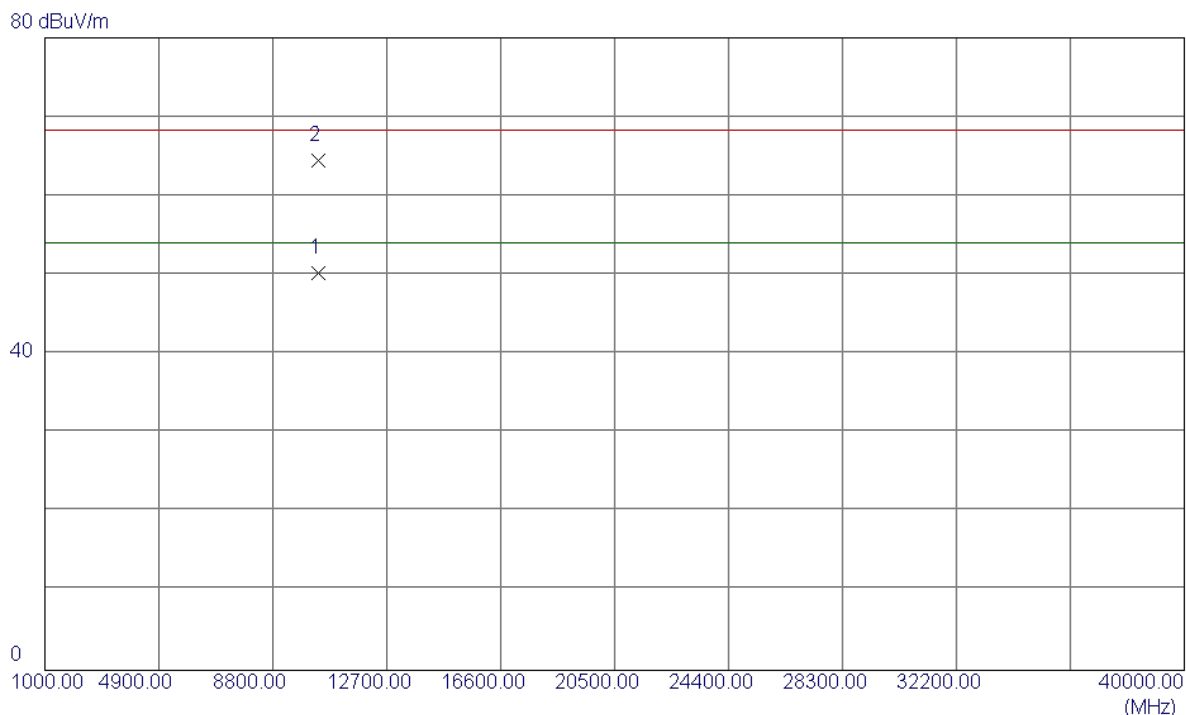

No.	Freq. MHz	Reading Level dBuV/m	Correct Factor dB	Measure ment dBuV/m	Limit dBuV/m	Margin dB	Detector	Comment
1 *	10380.0000	36.44	13.83	50.27	54.00	-3.73	AVG	
2	10380.4000	50.65	13.83	64.48	68.30	-3.82	Peak	

Orthogonal Axis:	X
Test Mode:	UNII-1/ TX N40 Mode 5230MHz

Vertical

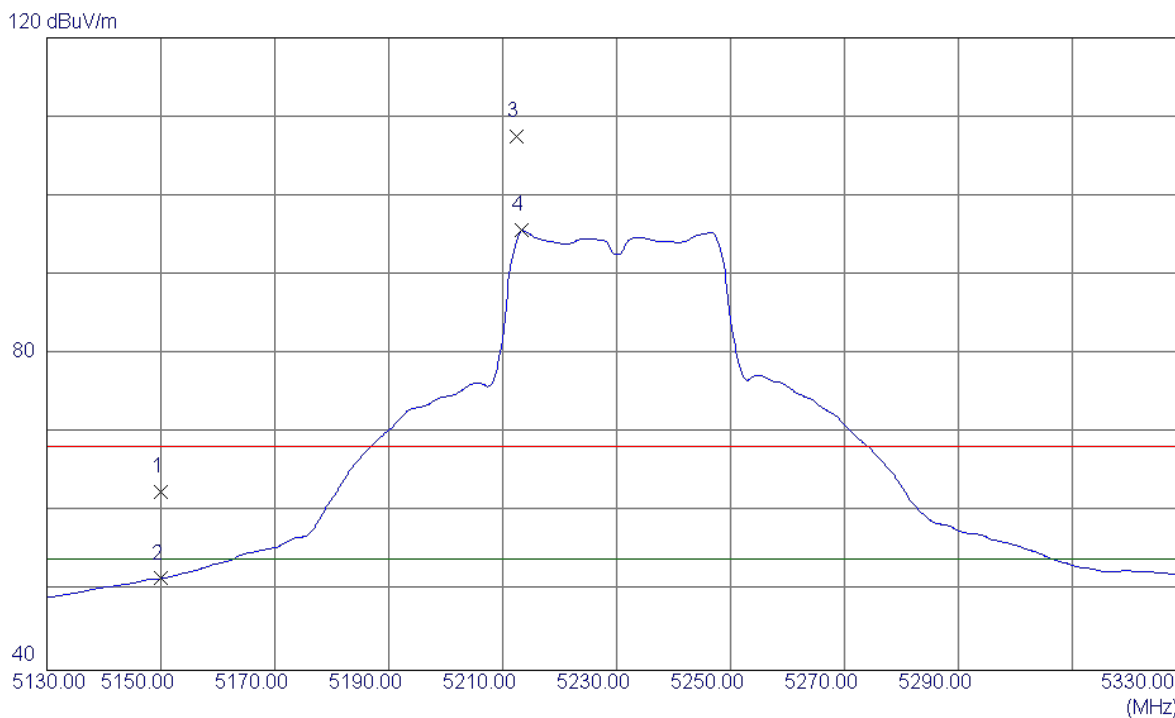

No.	Freq. MHz	Reading Level dBuV/m	Correct Factor dB	Measure ment dBuV/m	Limit dBuV/m	Margin dB	Detector	Comment
1	5150.0000	22.34	40.22	62.56	68.30	-5.74	Peak	
2	5150.0000	11.38	40.22	51.60	54.00	-2.40	AVG	
3	5212.4000	67.15	40.35	107.50	68.30	39.20	Peak	No Limit
4 *	5213.4000	55.26	40.35	95.61	54.00	41.61	AVG	No Limit

Orthogonal Axis:	X
Test Mode:	UNII-1/ TX N40 Mode 5230MHz

Vertical

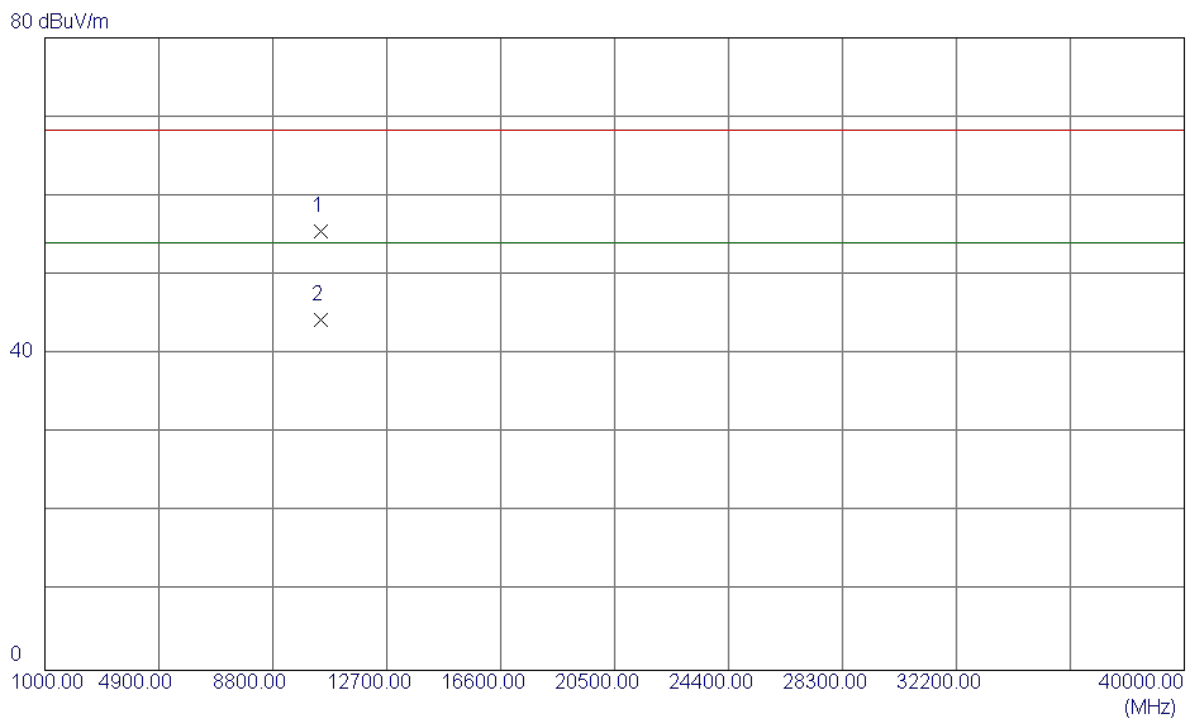

No.	Freq. MHz	Reading Level dBuV/m	Correct Factor dB	Measure ment dBuV/m	Limit dBuV/m	Margin dB	Detector	Comment
1	10460.4000	41.82	13.72	55.54	68.30	-12.76	Peak	
2 *	10460.8000	30.53	13.72	44.25	54.00	-9.75	AVG	

Orthogonal Axis:	X
Test Mode:	UNII-1/ TX N40 Mode 5230MHz

Horizontal

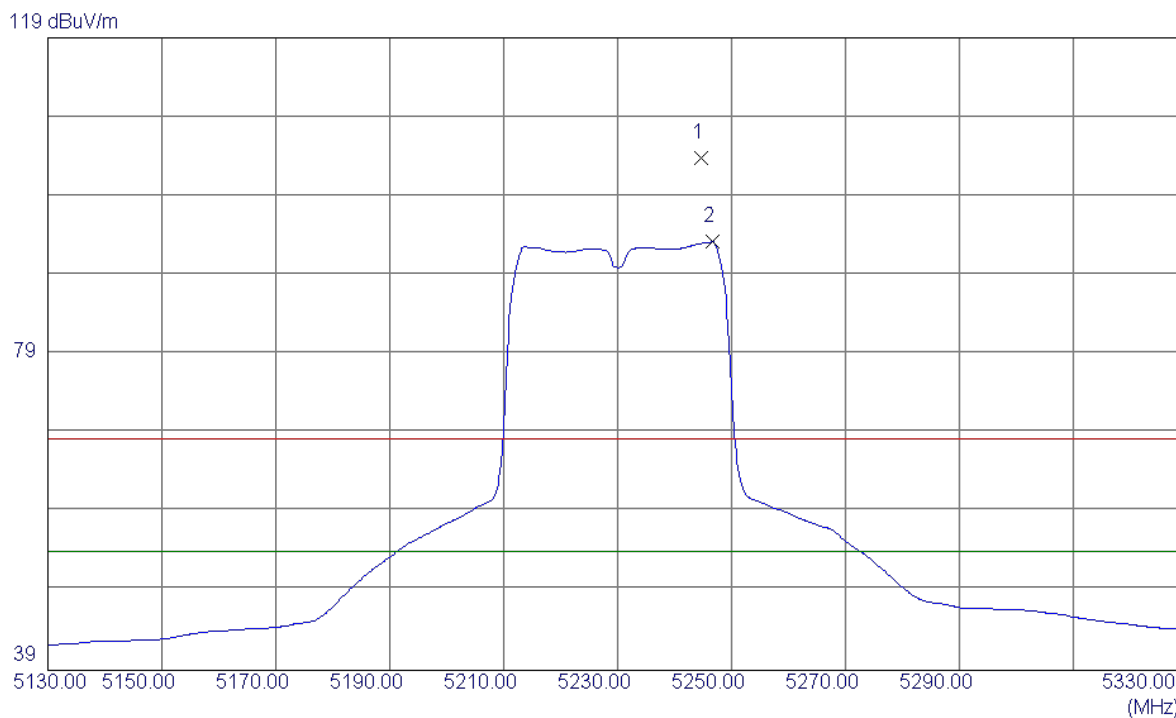

No.	Freq. MHz	Reading Level dBuV/m	Correct Factor dB	Measure ment dBuV/m	Limit dBuV/m	Margin dB	Detector	Comment
1	5244.6000	63.37	40.42	103.79	68.30	35.49	Peak	No Limit
2 *	5246.6000	52.76	40.42	93.18	54.00	39.18	AVG	No Limit

Orthogonal Axis:	X
Test Mode:	UNII-1/ TX N40 Mode 5230MHz

Horizontal

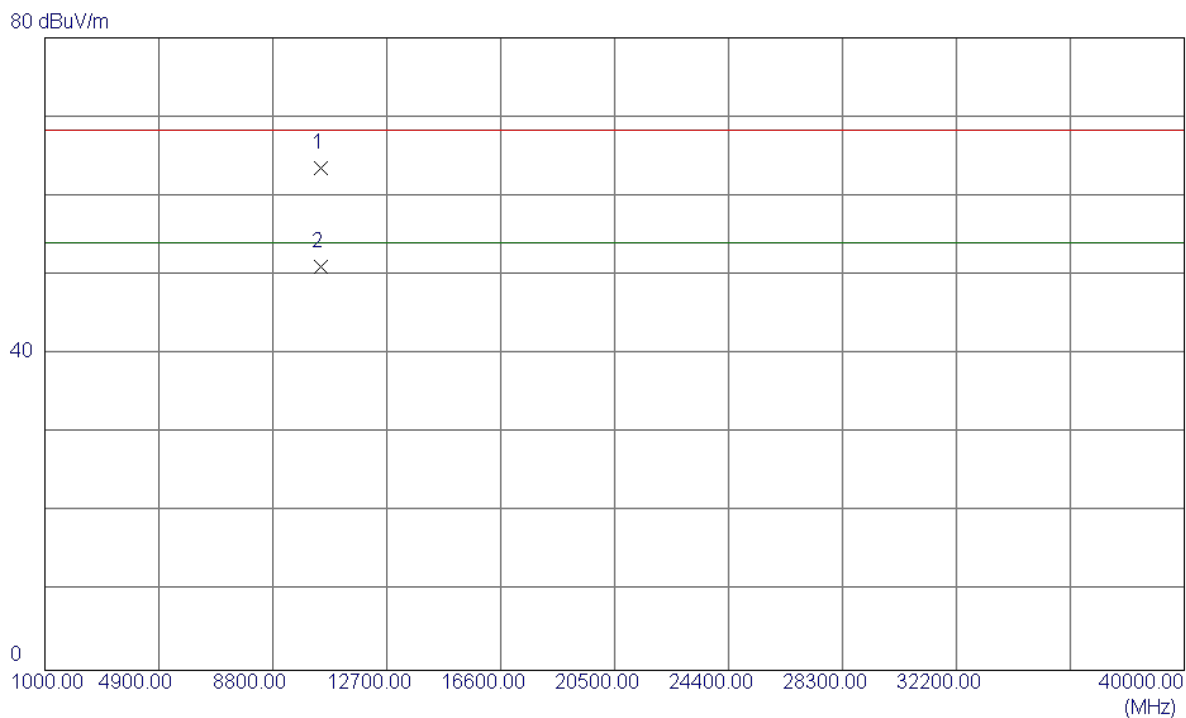

No.	Freq. MHz	Reading Level dBuV/m	Correct Factor dB	Measure ment dBuV/m	Limit dBuV/m	Margin dB	Detector	Comment
1	10461.2000	49.79	13.72	63.51	68.30	-4.79	Peak	
2 *	10461.2000	37.34	13.72	51.06	54.00	-2.94	AVG	

Orthogonal Axis:	X
Test Mode:	UNII-3/TX A Mode 5745MHz

Vertical

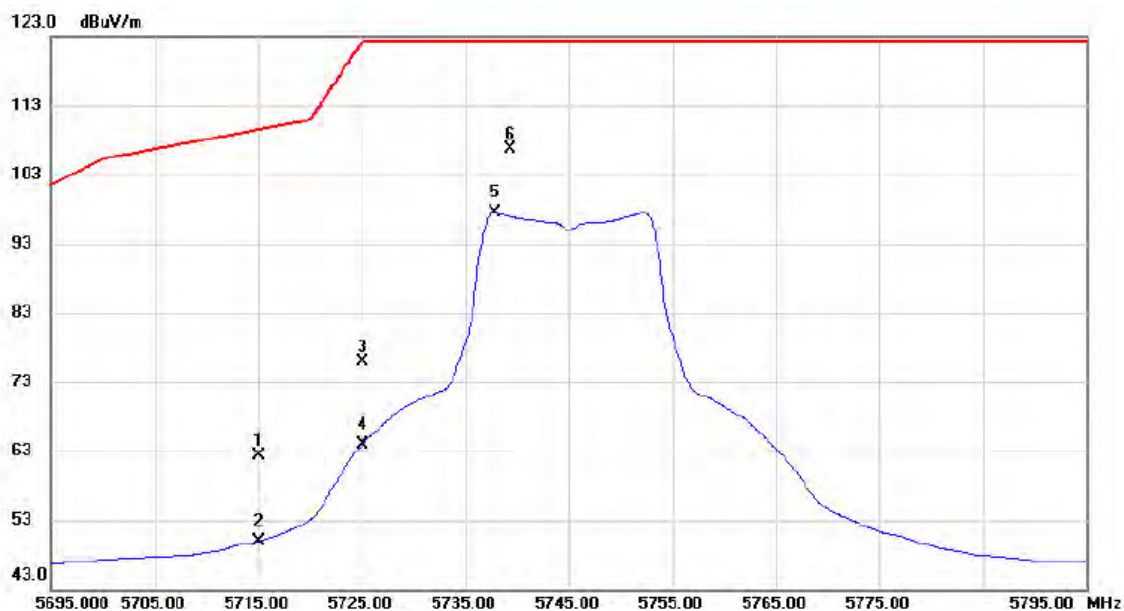

No.	Mk.	Freq. MHz	Reading Level dBuV	Correct Factor dB	Measure- ment dBuV/m	Limit dBuV/m	Margin dB	Detector	Comment
1		5715.000	20.97	41.25	62.22	109.50	-47.28	peak	
2		5715.000	8.66	41.25	49.91	109.50	-59.59	AVG	
3		5725.000	34.59	41.27	75.86	122.30	-46.44	peak	
4		5725.000	22.64	41.27	63.91	122.30	-58.39	AVG	
5		5737.800	56.20	41.28	97.48	122.30	-24.82	AVG	No Limit
6	*	5739.300	65.43	41.28	106.71	122.30	-15.59	peak	No Limit

Orthogonal Axis:	X
Test Mode:	UNII-3/TX A Mode 5745MHz

Vertical

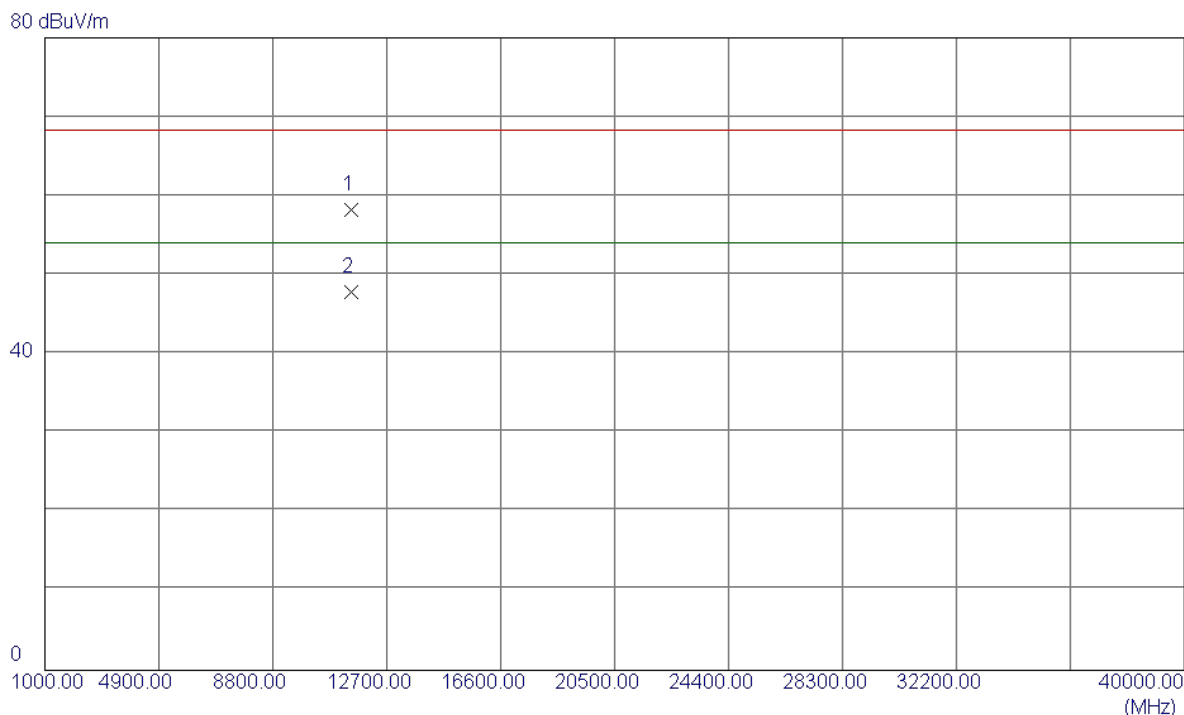

No.	Freq. MHz	Reading Level dBuV/m	Correct Factor dB	Measure ment dBuV/m	Limit dBuV/m	Margin dB	Detector	Comment
1	11489.9000	41.38	16.91	58.29	68.30	-10.01	Peak	
2 *	11490.0000	30.89	16.91	47.80	54.00	-6.20	AVG	

Orthogonal Axis:	X
Test Mode:	UNII-3/TX A Mode 5745MHz

Horizontal

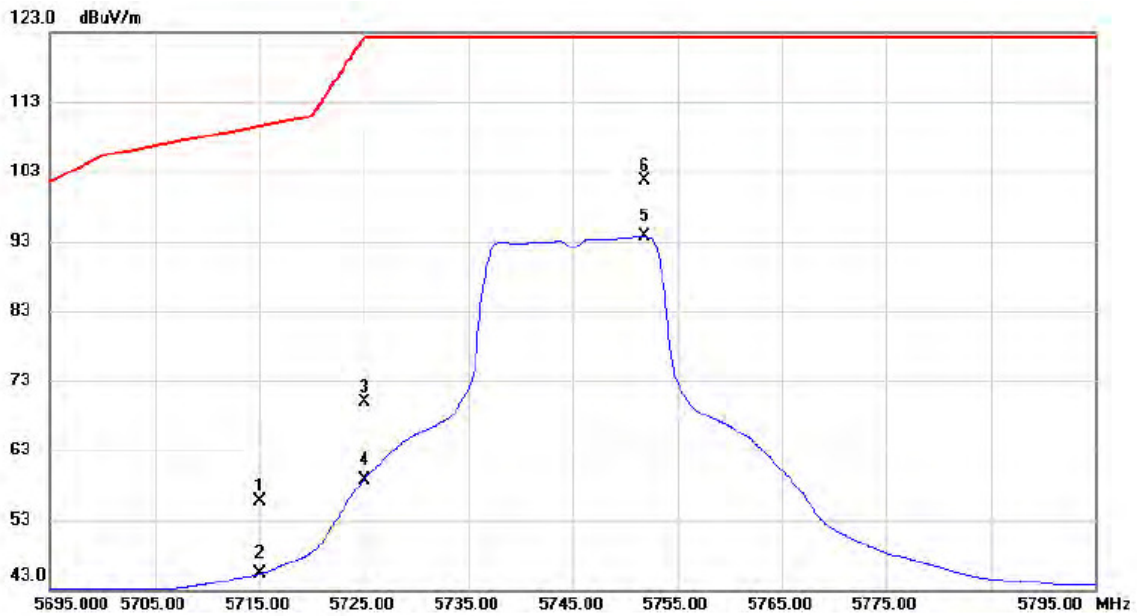

No.	Mk.	Freq. MHz	Reading Level dBuV	Correct Factor dB	Measure- ment dBuV/m	Limit dBuV/m	Margin dB	Detector	Comment
1		5715.000	14.44	41.25	55.69	109.50	-53.81	peak	
2		5715.000	4.00	41.25	45.25	109.50	-64.25	AVG	
3		5725.000	28.66	41.27	69.93	122.30	-52.37	peak	
4		5725.000	17.52	41.27	58.79	122.30	-63.51	AVG	
5		5751.800	52.39	41.30	93.69	122.30	-28.61	AVG	No Limit
6	*	5751.900	60.48	41.30	101.78	122.30	-20.52	peak	No Limit

Orthogonal Axis:	X
Test Mode:	UNII-3/TX A Mode 5745MHz

Horizontal

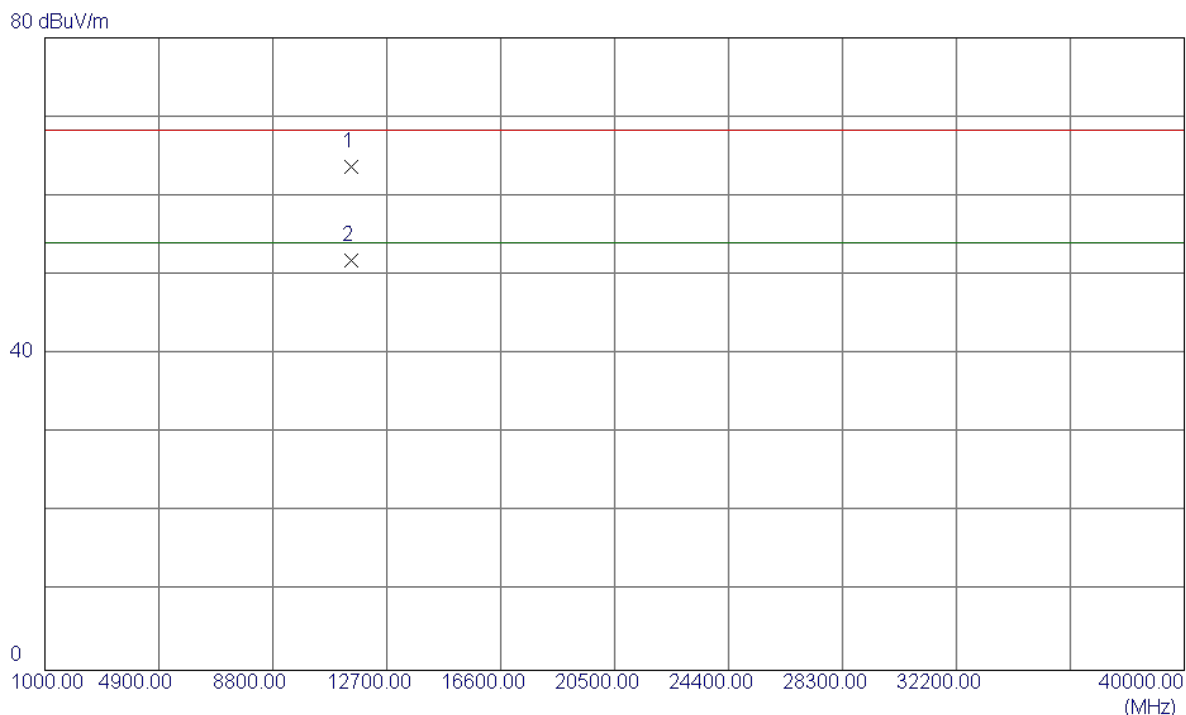

No.	Freq. MHz	Reading Level dBuV/m	Correct Factor dB	Measure ment dBuV/m	Limit dBuV/m	Margin dB	Detector	Comment
1	11485.7000	46.78	16.90	63.68	68.30	-4.62	Peak	
2 *	11490.0000	35.01	16.91	51.92	54.00	-2.08	AVG	

Orthogonal Axis:	X
Test Mode:	UNII-3/TX A Mode 5785MHz

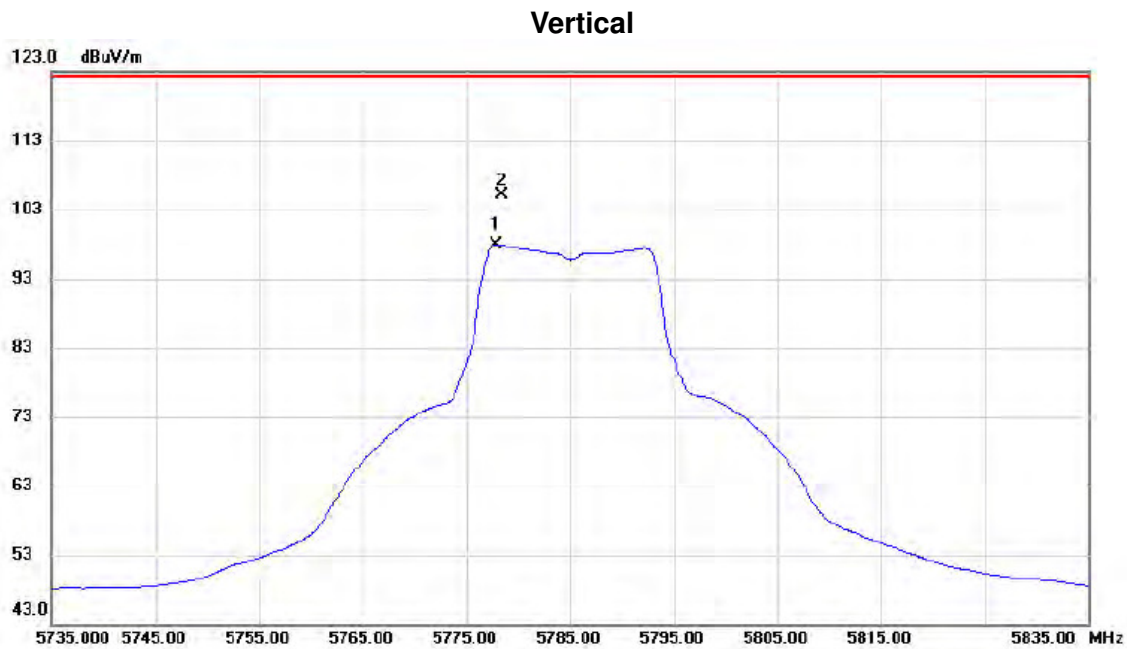

No.	Mk.	Freq. MHz	Reading Level dBuV	Correct Factor dB	Measure- ment dBuV/m	Limit dBuV/m	Margin dB	Detector	Comment
1		5777.800	56.67	41.33	98.00	122.30	-24.30	AVG	No Limit
2	*	5778.400	63.79	41.34	105.13	122.30	-17.17	peak	No Limit

Orthogonal Axis:	X
Test Mode:	UNII-3/TX A Mode 5785MHz

Vertical

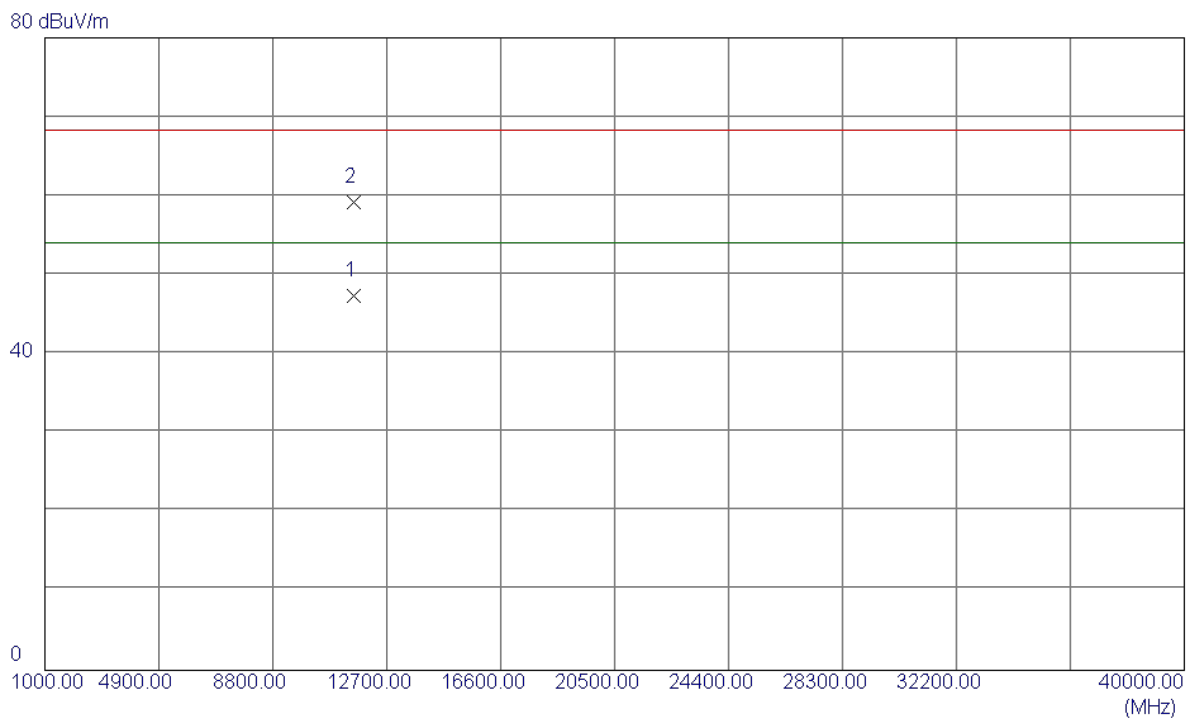

No.	Freq. MHz	Reading Level dBuV/m	Correct Factor dB	Measure ment dBuV/m	Limit dBuV/m	Margin dB	Detector	Comment
1 *	11570.0000	30.38	17.05	47.43	54.00	-6.57	AVG	
2	11570.1000	42.12	17.05	59.17	68.30	-9.13	Peak	

Orthogonal Axis:	X
Test Mode:	UNII-3/TX A Mode 5785MHz

Horizontal

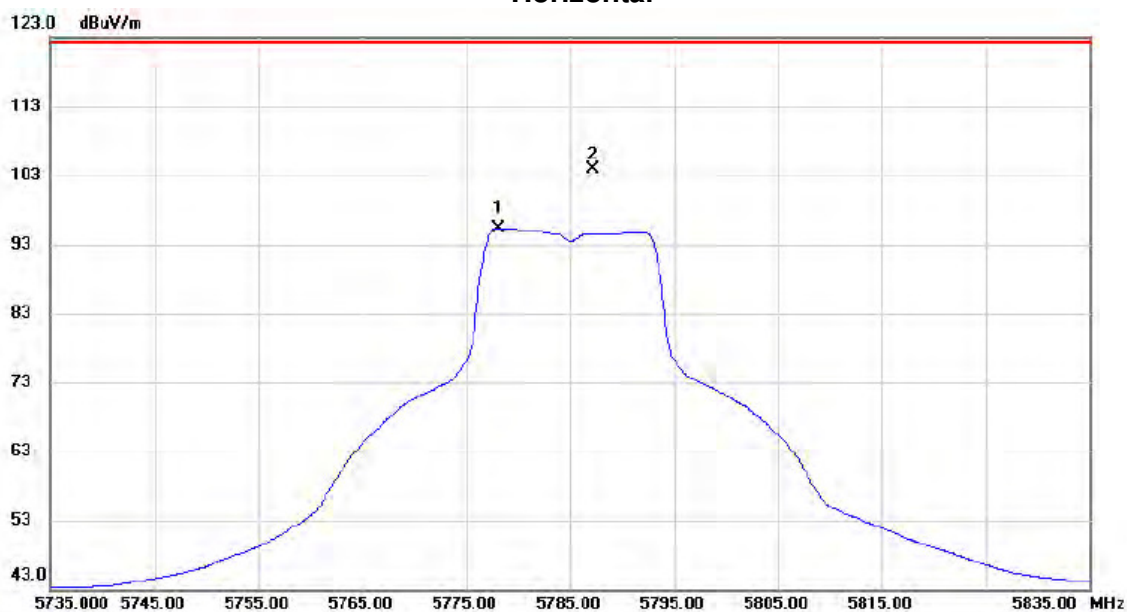

No.	Mk.	Freq. MHz	Reading Level dBuV	Correct Factor dB	Measure- ment dBuV/m	Limit dBuV/m	Margin dB	Detector	Comment
1		5778.200	54.03	41.34	95.37	122.30	-26.93	AVG	No Limit
2	*	5787.200	62.60	41.35	103.95	122.30	-18.35	peak	No Limit

Orthogonal Axis:	X
Test Mode:	UNII-3/TX A Mode 5785MHz

Horizontal

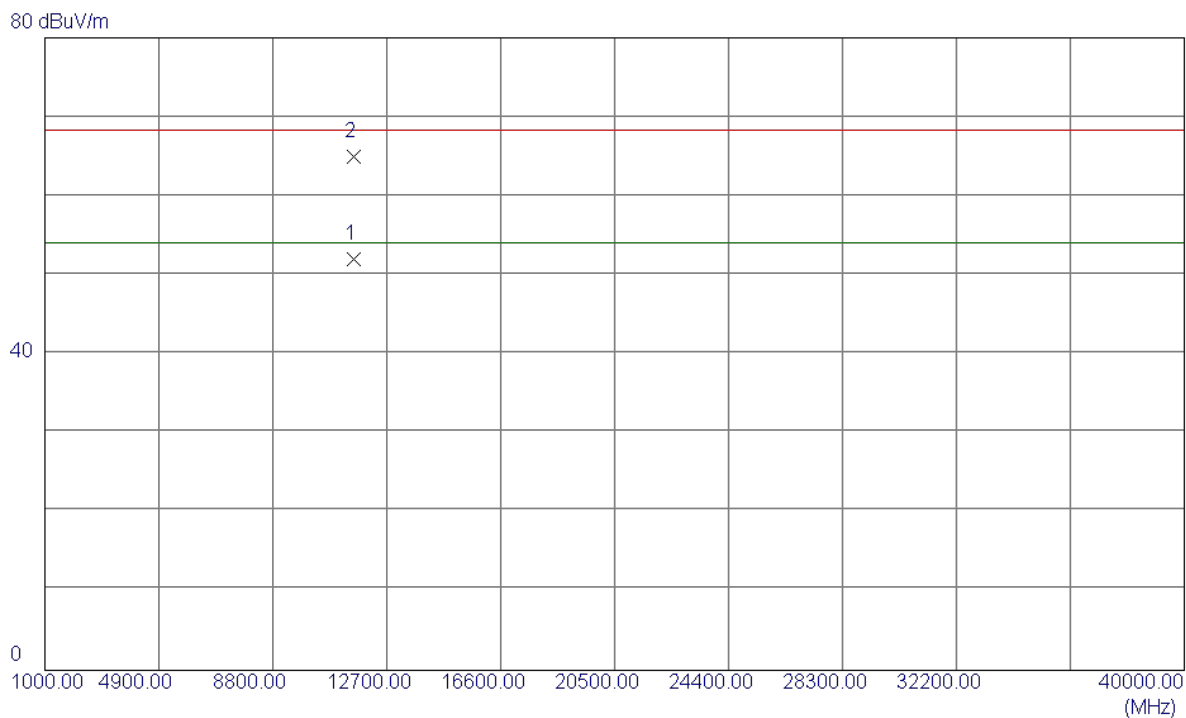

No.	Freq. MHz	Reading Level dBuV/m	Correct Factor dB	Measure ment dBuV/m	Limit dBuV/m	Margin dB	Detector	Comment
1 *	11570.0000	34.92	17.05	51.97	54.00	-2.03	AVG	
2	11570.4000	47.88	17.05	64.93	68.30	-3.37	Peak	

Orthogonal Axis:	X
Test Mode:	UNII-3/TX A Mode 5825MHz

Vertical

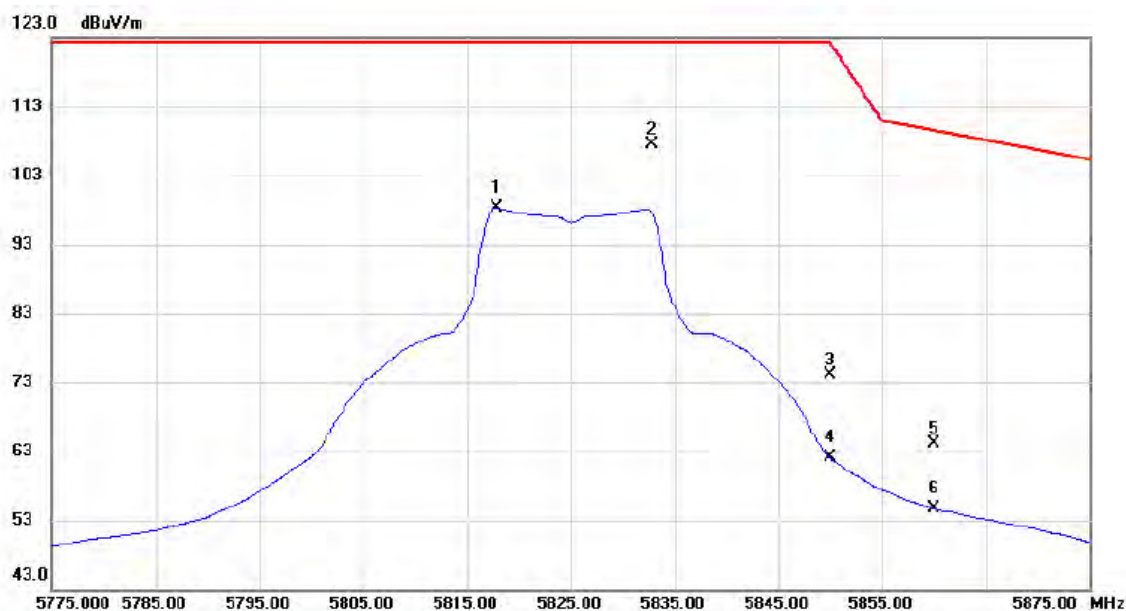

No. Mk.	Freq. MHz	Reading Level dBuV	Correct Factor dB	Measurement dBuV/m	Limit dBuV/m	Margin dB	Detector	Comment
1	5817.800	56.93	41.39	98.32	122.30	-23.98	AVG	No Limit
2 *	5832.800	66.01	41.41	107.42	122.30	-14.88	peak	No Limit
3	5850.000	32.74	41.44	74.18	122.30	-48.12	peak	
4	5850.000	20.59	41.44	62.03	122.30	-60.27	AVG	
5	5860.000	22.58	41.45	64.03	109.50	-45.47	peak	
6	5860.000	13.24	41.45	54.69	109.50	-54.81	AVG	

Orthogonal Axis:	X
Test Mode:	UNII-3/TX A Mode 5825MHz

Vertical

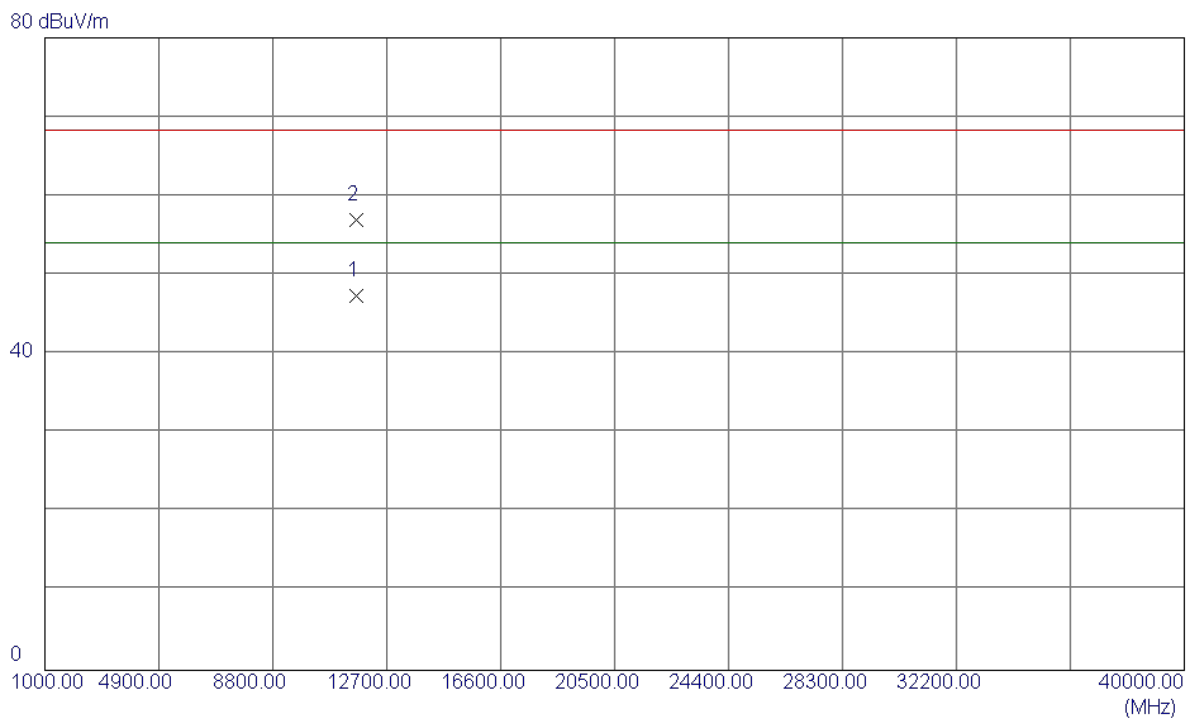

No.	Freq. MHz	Reading Level dBuV/m	Correct Factor dB	Measure ment dBuV/m	Limit dBuV/m	Margin dB	Detector	Comment
1 *	11650.0000	30.19	17.17	47.36	54.00	-6.64	AVG	
2	11649.9000	39.86	17.17	57.03	68.30	-11.27	Peak	

Orthogonal Axis:	X
Test Mode:	UNII-3/TX A Mode 5825MHz

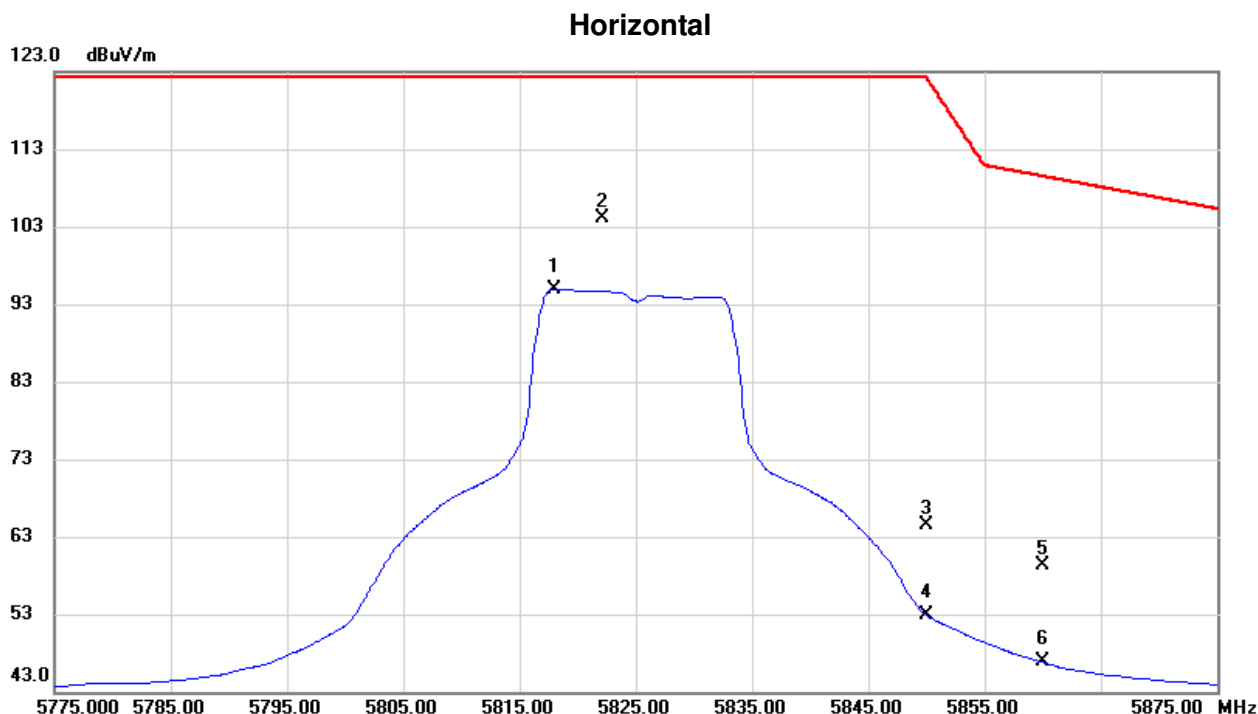

No.	Freq. MHz	Reading Level dBuV/m	Correct Factor dB	Measure ment dBuV/m	Limit dBuV/m	Margin dB	Detector	Comment
1	5818.0000	53.53	41.39	94.92	122.30	-27.38	AVG	No Limit
2 *	5822.2000	62.63	41.40	104.03	122.30	-18.27	Peak	No Limit
3	5850.0000	23.10	41.44	64.54	122.30	-57.76	Peak	
4	5850.0000	11.46	41.44	52.90	122.30	-69.40	AVG	
5	5860.0000	17.77	41.45	59.22	109.50	-50.28	Peak	
6	5860.0000	5.36	41.45	46.81	109.50	-62.69	AVG	

Orthogonal Axis:	X
Test Mode:	UNII-3/TX A Mode 5825MHz

Horizontal

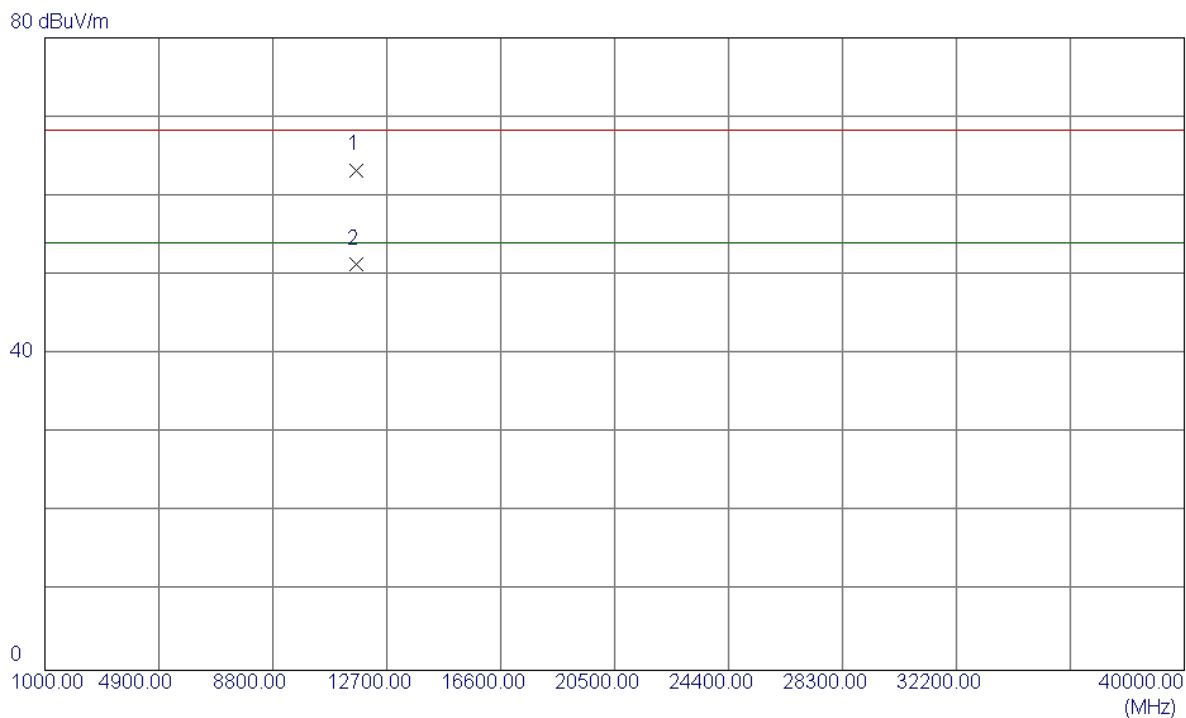

No.	Freq. MHz	Reading Level dBuV/m	Correct Factor dB	Measure ment dBuV/m	Limit dBuV/m	Margin dB	Detector	Comment
1	11648.7000	46.11	17.17	63.28	68.30	-5.02	Peak	
2 *	11650.0000	34.26	17.17	51.43	54.00	-2.57	AVG	

Orthogonal Axis:	X
Test Mode:	UNII-3/TX N20 Mode 5745MHz

Vertical

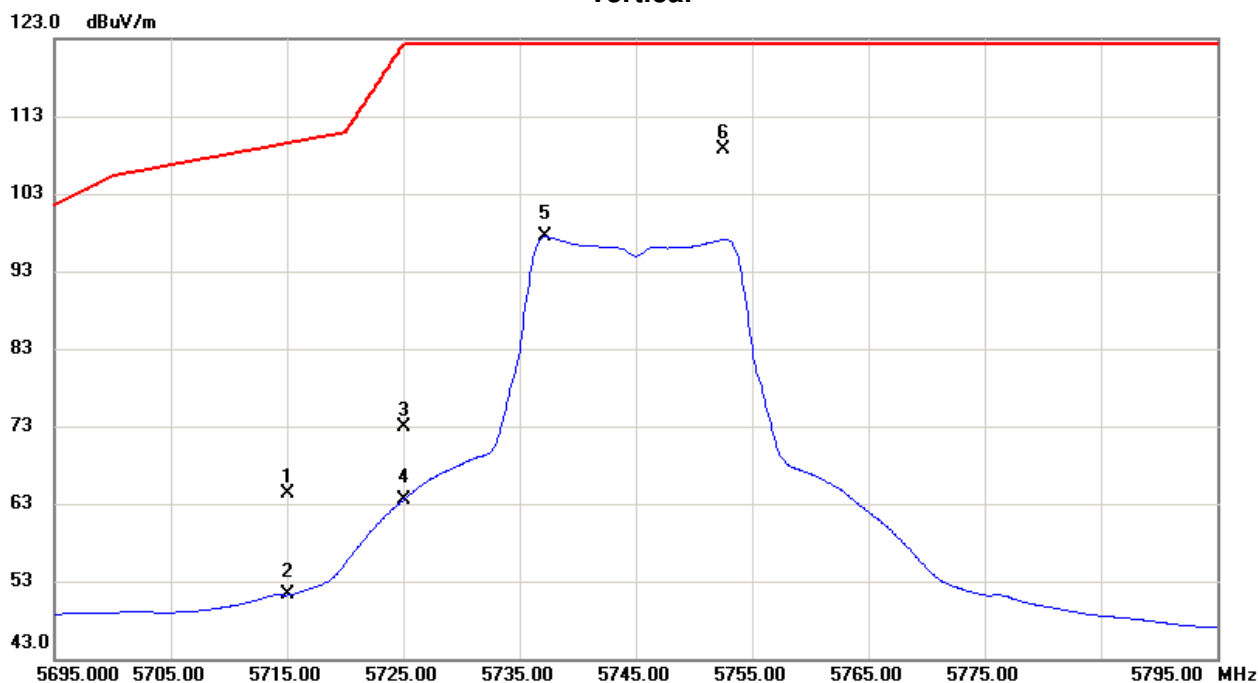

No.	Freq. MHz	Reading Level dBuV/m	Correct Factor dB	Measure ment dBuV/m	Limit dBuV/m	Margin dB	Detector	Comment
1	5715.0000	23.09	41.25	64.34	109.50	-45.16	Peak	
2	5715.0000	9.96	41.25	51.21	109.50	-58.29	AVG	
3	5725.0000	31.73	41.27	73.00	122.30	-49.30	Peak	
4	5725.0000	22.20	41.27	63.47	122.30	-58.83	AVG	
5	5737.2000	56.18	41.28	97.46	122.30	-24.84	AVG	No Limit
6 *	5752.5000	67.44	41.30	108.74	122.30	-13.56	Peak	No Limit

Orthogonal Axis:	X
Test Mode:	UNII-3/TX N20 Mode 5745MHz

Vertical

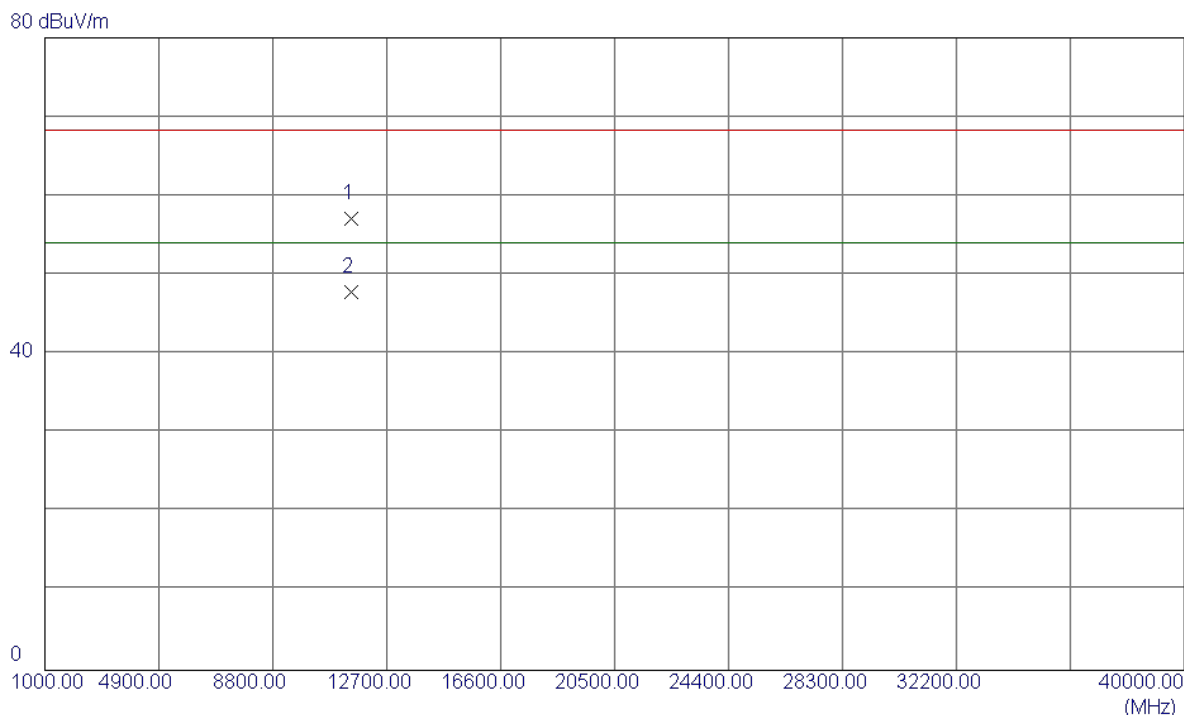

No.	Freq. MHz	Reading Level dBuV/m	Correct Factor dB	Measure ment dBuV/m	Limit dBuV/m	Margin dB	Detector	Comment
1	11490.0000	40.28	16.91	57.19	68.30	-11.11	Peak	
2 *	11490.0000	30.99	16.91	47.90	54.00	-6.10	AVG	

Orthogonal Axis:	X
Test Mode:	UNII-3/TX N20 Mode 5745MHz

Horizontal

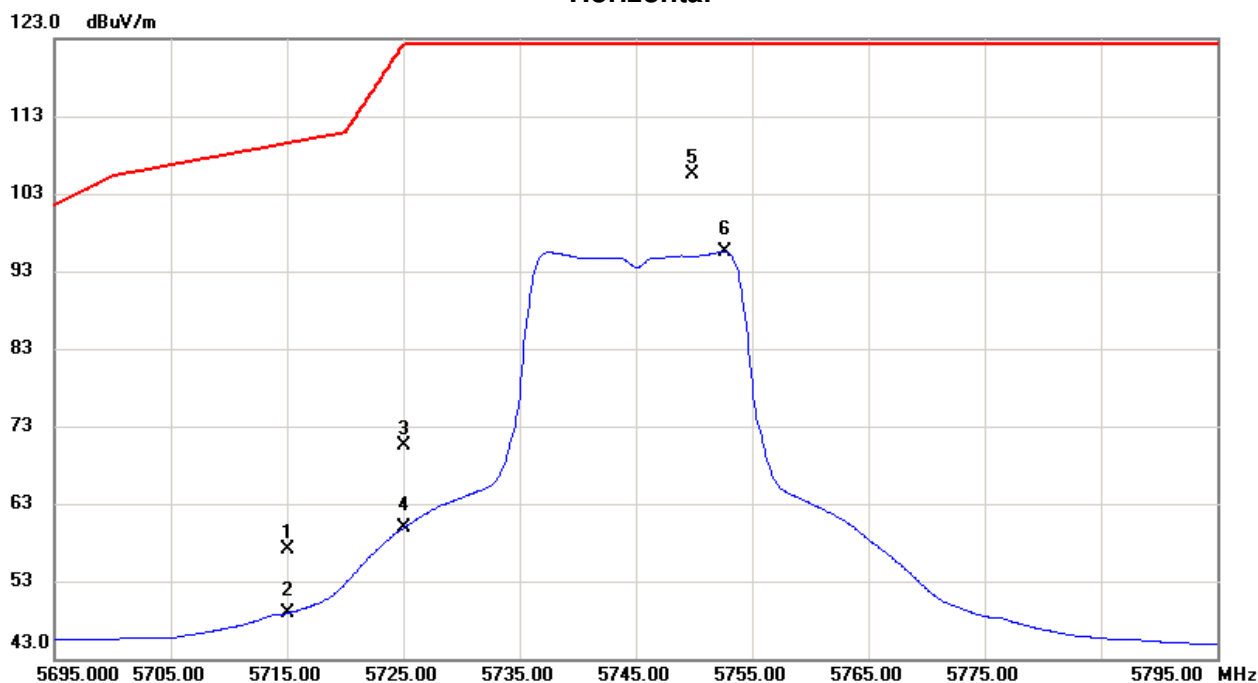

No.	Freq. MHz	Reading Level dBuV/m	Correct Factor dB	Measure ment dBuV/m	Limit dBuV/m	Margin dB	Detector	Comment
1	5715.0000	15.80	41.25	57.05	109.50	-52.45	Peak	
2	5715.0000	7.60	41.25	48.85	109.50	-60.65	AVG	
3	5725.0000	29.13	41.27	70.40	122.30	-51.90	Peak	
4	5725.0000	18.57	41.27	59.84	122.30	-62.46	AVG	
5 *	5749.8000	64.16	41.30	105.46	122.30	-16.84	Peak	No Limit
6	5752.6000	54.22	41.30	95.52	122.30	-26.78	AVG	No Limit

Orthogonal Axis:	X
Test Mode:	UNII-3/TX N20 Mode 5745MHz

Horizontal

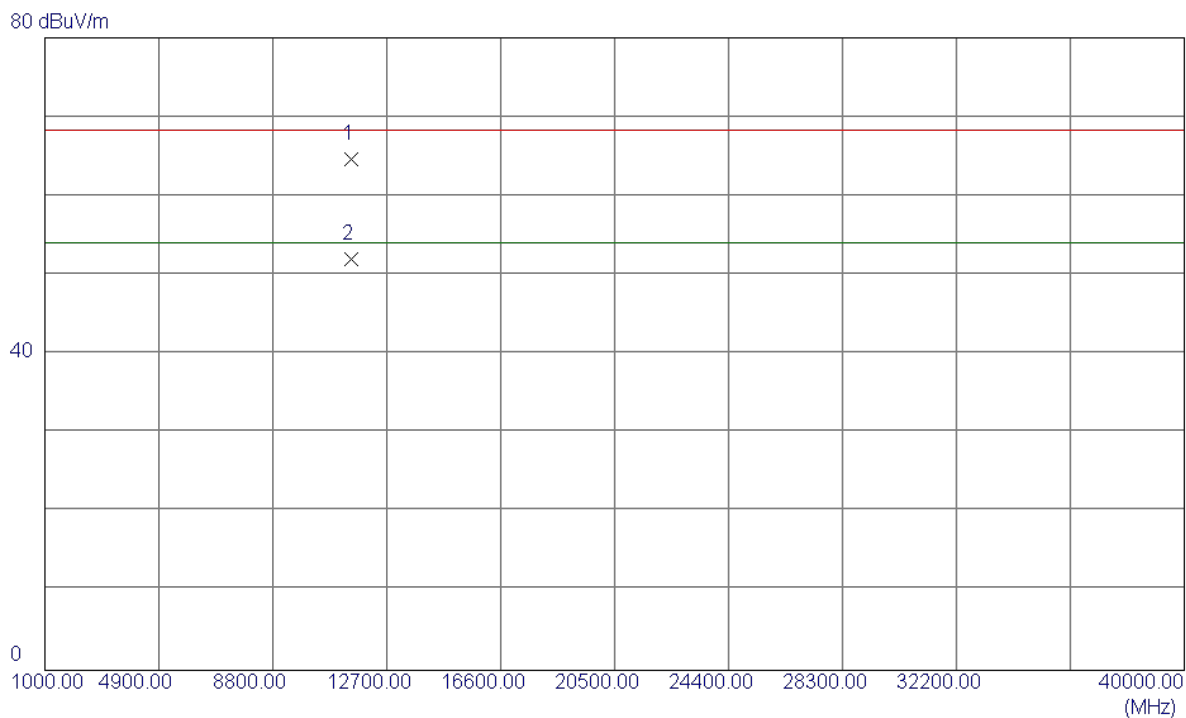

No.	Freq. MHz	Reading Level dBuV/m	Correct Factor dB	Measure ment dBuV/m	Limit dBuV/m	Margin dB	Detector	Comment
1	11486.6000	47.69	16.90	64.59	68.30	-3.71	Peak	
2 *	11490.3000	35.03	16.91	51.94	54.00	-2.06	AVG	

Orthogonal Axis:	X
Test Mode:	UNII-3/TX N20 Mode 5785MHz

Vertical

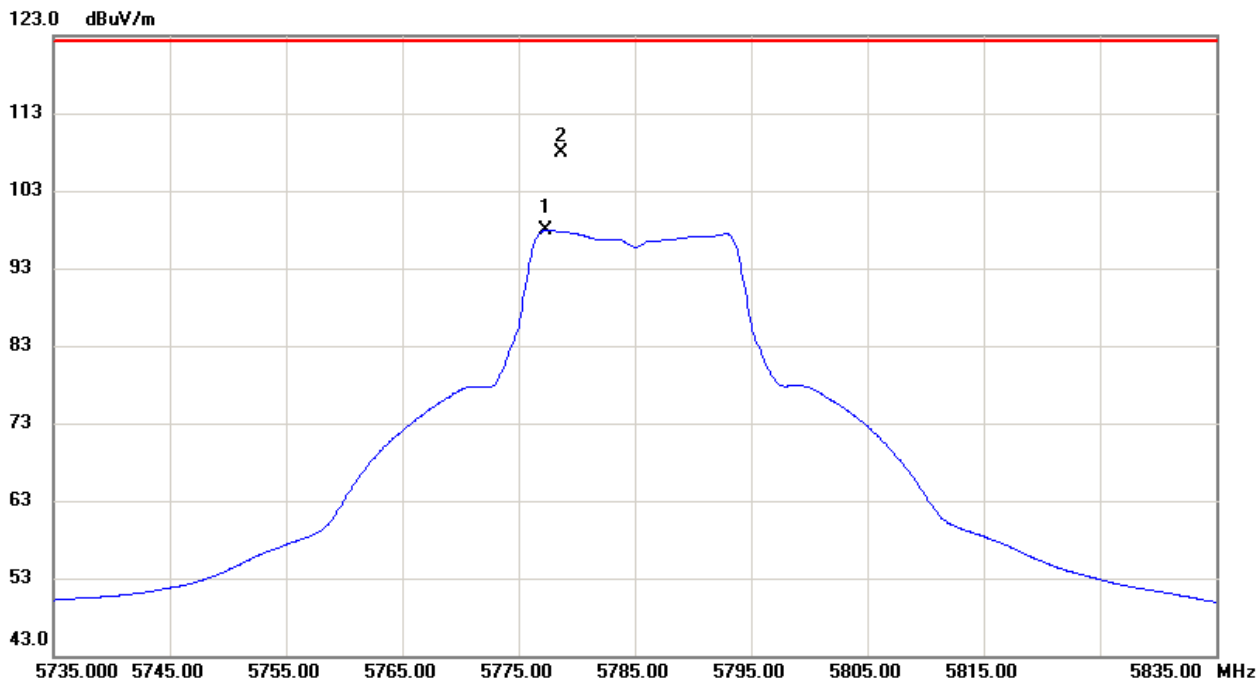

No.	Freq. MHz	Reading Level dBuV/m	Correct Factor dB	Measure ment dBuV/m	Limit dBuV/m	Margin dB	Detector	Comment
1	5777.3000	56.54	41.34	97.88	122.30	-24.42	AVG	No Limit
2 *	5778.6000	66.62	41.34	107.96	122.30	-14.34	Peak	No Limit

Orthogonal Axis:	X
Test Mode:	UNII-3/TX N20 Mode 5785MHz

Vertical

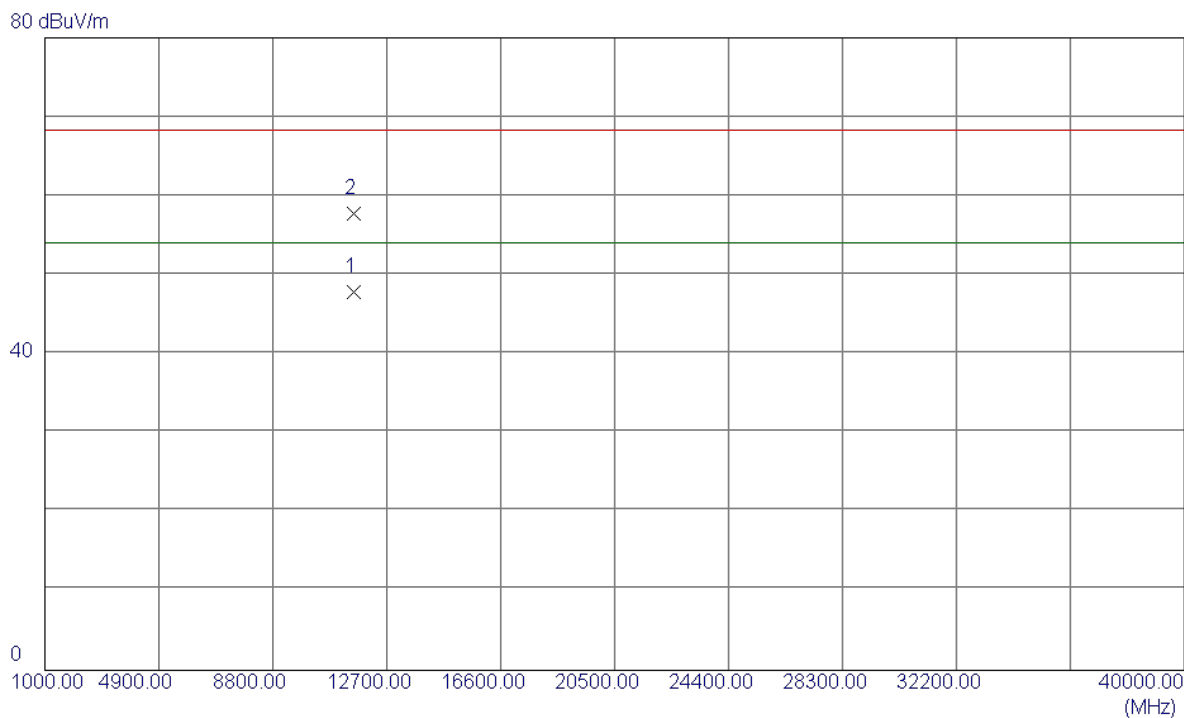

No.	Freq. MHz	Reading Level dBuV/m	Correct Factor dB	Measure ment dBuV/m	Limit dBuV/m	Margin dB	Detector	Comment
1 *	11570.0000	30.73	17.05	47.78	54.00	-6.22	AVG	
2	11570.1000	40.67	17.05	57.72	68.30	-10.58	Peak	

Orthogonal Axis:	X
Test Mode:	UNII-3/TX N20 Mode 5785MHz

Horizontal

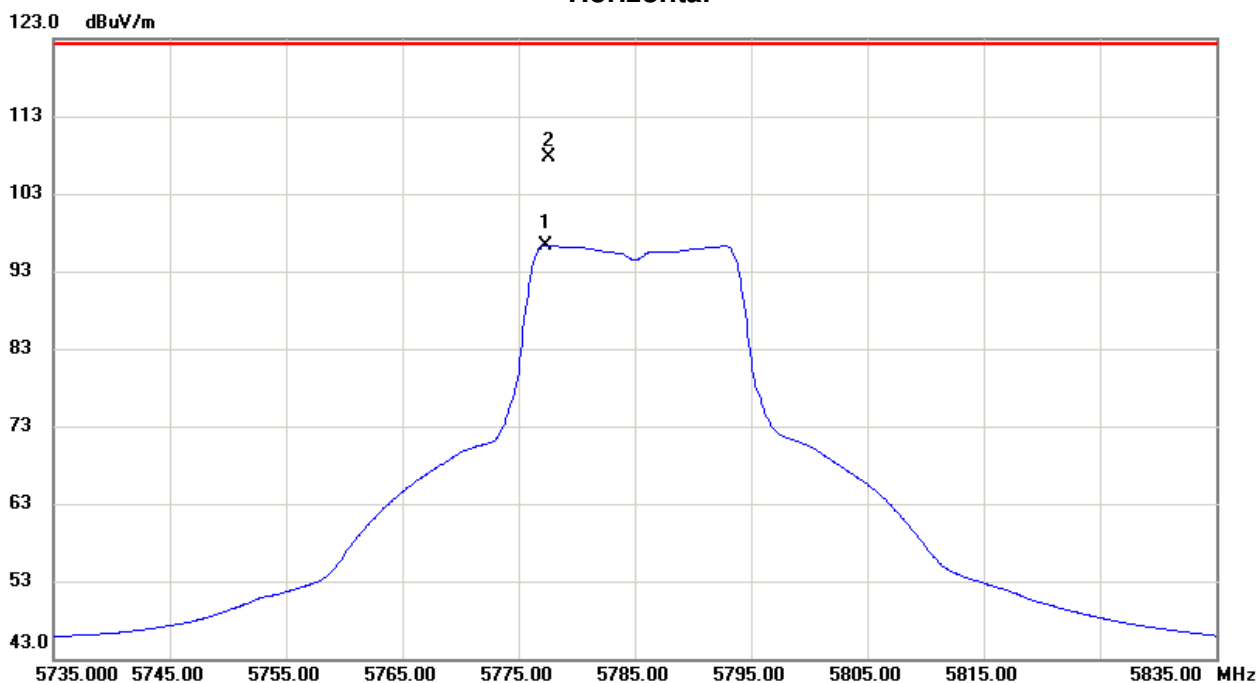

No.	Freq. MHz	Reading Level dBuV/m	Correct Factor dB	Measure ment dBuV/m	Limit dBuV/m	Margin dB	Detector	Comment
1	5777.4000	55.03	41.34	96.37	122.30	-25.93	AVG	No Limit
2 *	5777.6000	66.30	41.34	107.64	122.30	-14.66	Peak	No Limit

Orthogonal Axis:	X
Test Mode:	UNII-3/TX N20 Mode 5785MHz

Horizontal

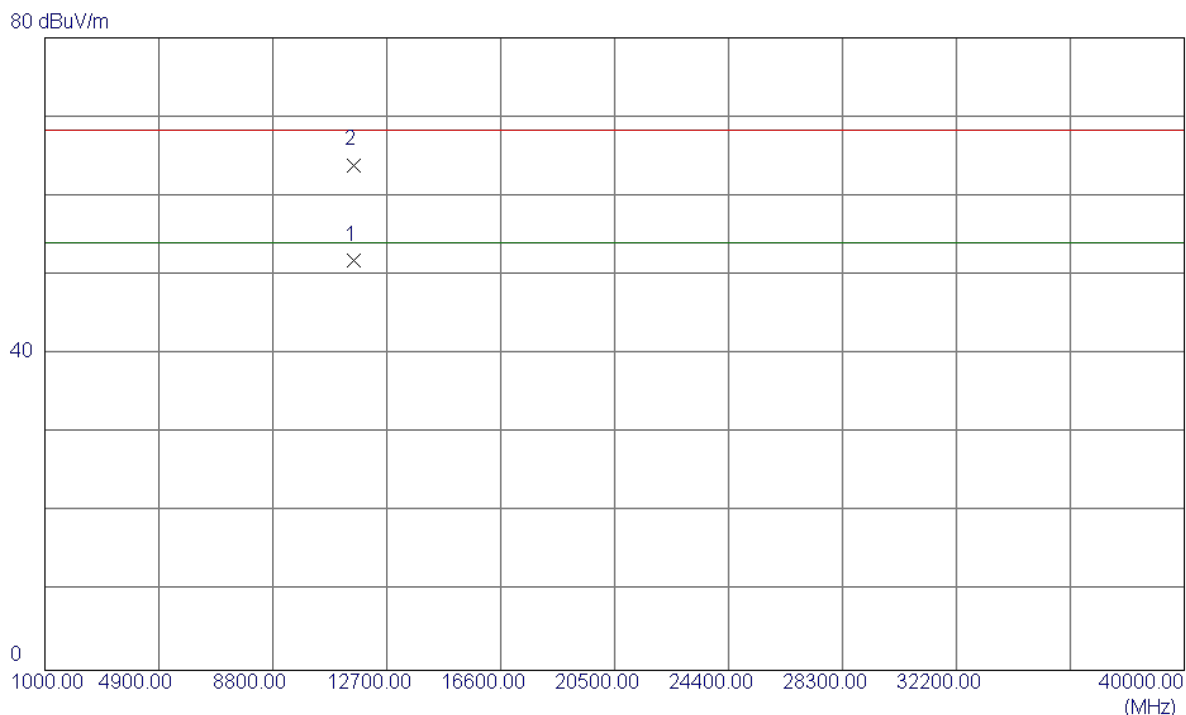

No.	Freq. MHz	Reading Level dBuV/m	Correct Factor dB	Measure ment dBuV/m	Limit dBuV/m	Margin dB	Detector	Comment
1 *	11570.4000	34.81	17.05	51.86	54.00	-2.14	AVG	
2	11571.5000	46.87	17.05	63.92	68.30	-4.38	Peak	

Orthogonal Axis:	X
Test Mode:	UNII-3/TX N20 Mode 5825MHz

Vertical

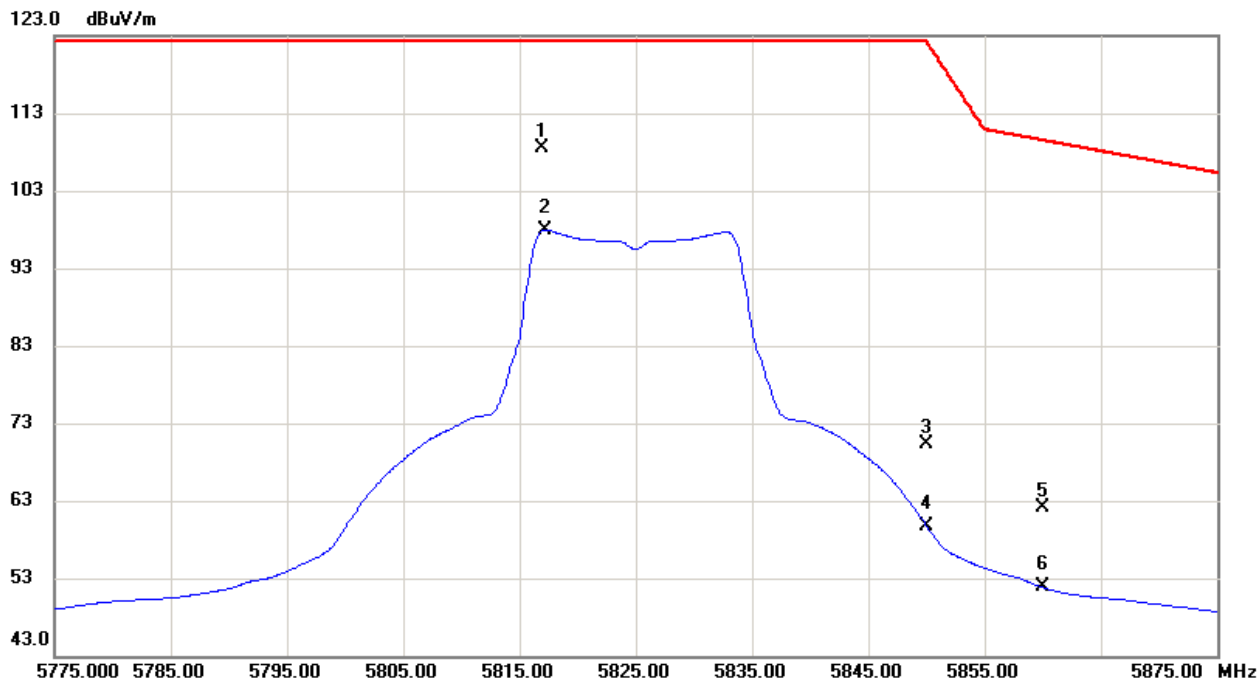

No.	Freq. MHz	Reading Level dBuV/m	Correct Factor dB	Measure ment dBuV/m	Limit dBuV/m	Margin dB	Detector	Comment
1 *	5816.9000	67.16	41.39	108.55	122.30	-13.75	Peak	No Limit
2	5817.2000	56.59	41.39	97.98	122.30	-24.32	AVG	No Limit
3	5850.0000	28.85	41.44	70.29	122.30	-52.01	Peak	
4	5850.0000	18.34	41.44	59.78	122.30	-62.52	AVG	
5	5860.0000	20.63	41.45	62.08	109.50	-47.42	Peak	
6	5860.0000	10.36	41.45	51.81	109.50	-57.69	AVG	

Orthogonal Axis:	X
Test Mode:	UNII-3/TX N20 Mode 5825MHz

Vertical

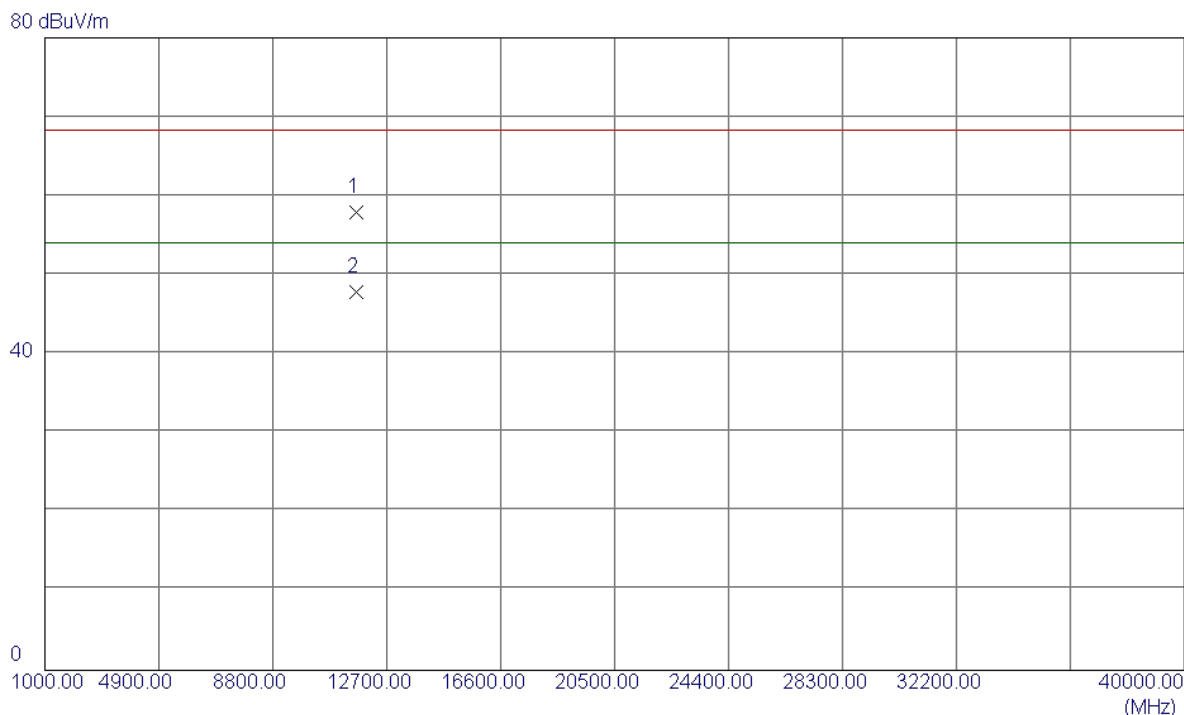

No.	Freq. MHz	Reading Level dBuV/m	Correct Factor dB	Measure ment dBuV/m	Limit dBuV/m	Margin dB	Detector	Comment
1	11649.6000	40.72	17.17	57.89	68.30	-10.41	Peak	
2 *	11650.0000	30.60	17.17	47.77	54.00	-6.23	AVG	

Orthogonal Axis:	X
Test Mode:	UNII-3/TX N20 Mode 5825MHz

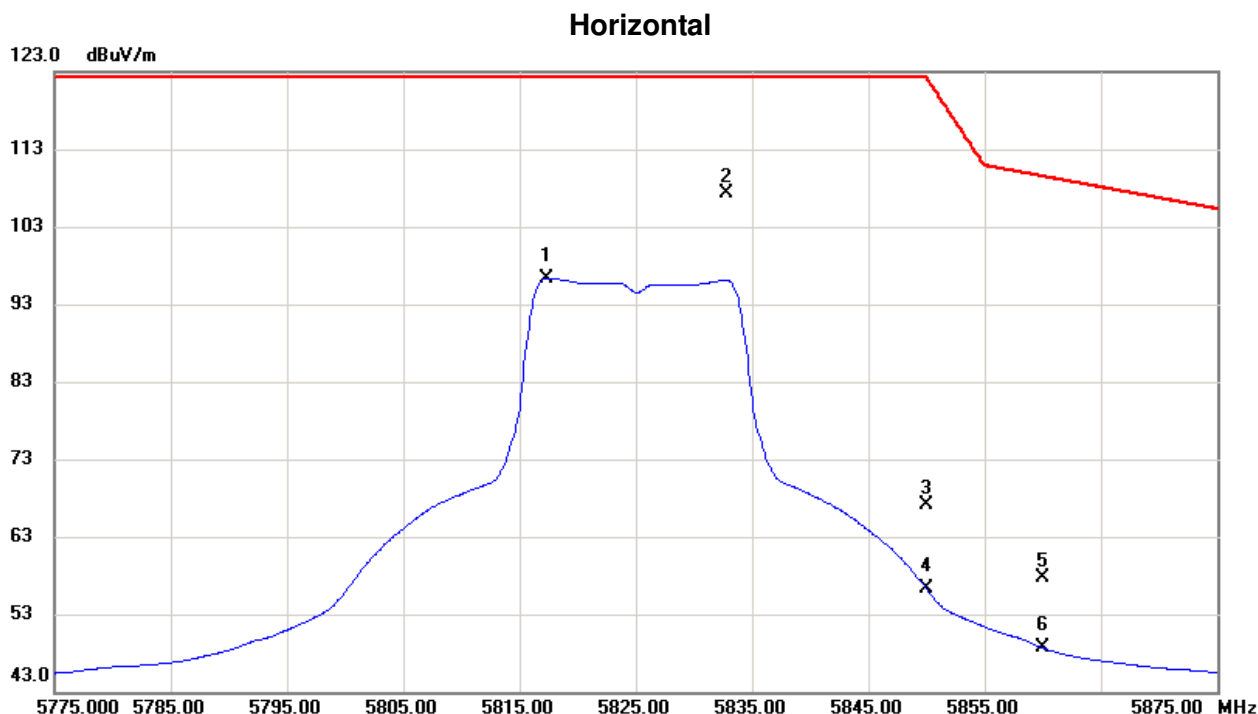

No.	Freq. MHz	Reading Level dBuV/m	Correct Factor dB	Measure ment dBuV/m	Limit dBuV/m	Margin dB	Detector	Comment
1	5817.4000	54.96	41.39	96.35	122.30	-25.95	AVG	No Limit
2 *	5832.8000	65.89	41.41	107.30	122.30	-15.00	Peak	No Limit
3	5850.0000	25.61	41.44	67.05	122.30	-55.25	Peak	
4	5850.0000	14.78	41.44	56.22	122.30	-66.08	AVG	
5	5860.0000	16.31	41.45	57.76	109.50	-51.74	Peak	
6	5860.0000	7.21	41.45	48.66	109.50	-60.84	AVG	

Orthogonal Axis:	X
Test Mode:	UNII-3/TX N20 Mode 5825MHz

Horizontal

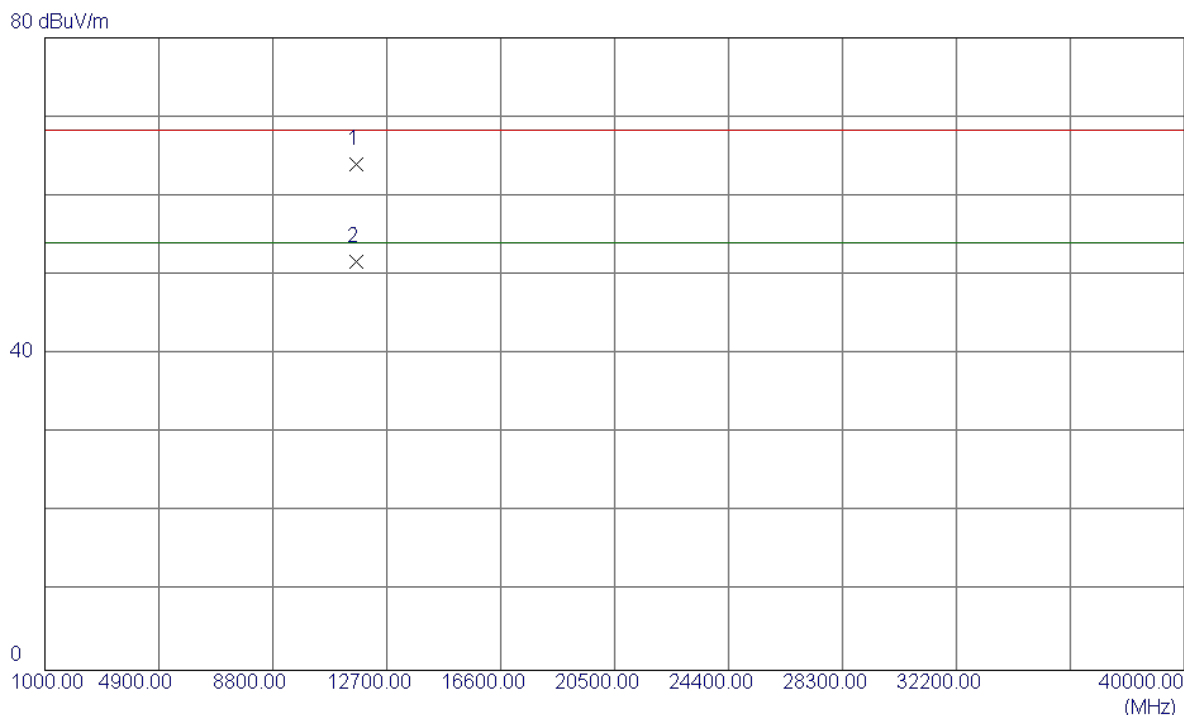

No.	Freq. MHz	Reading Level dBuV/m	Correct Factor dB	Measure ment dBuV/m	Limit dBuV/m	Margin dB	Detector	Comment
1	11646.5000	46.85	17.17	64.02	68.30	-4.28	Peak	
2 *	11650.2000	34.46	17.17	51.63	54.00	-2.37	AVG	

Orthogonal Axis:	X
Test Mode:	UNII-3/TX N40 Mode 5755MHz

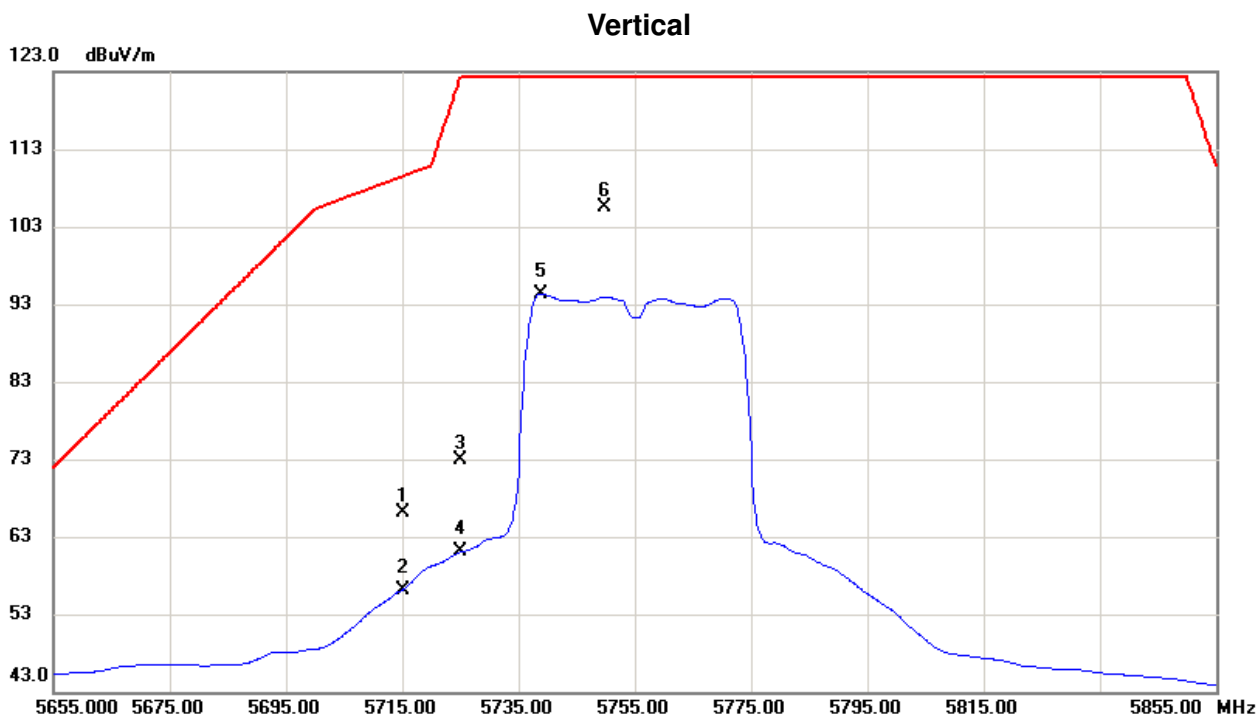

No.	Freq. MHz	Reading Level dBuV/m	Correct Factor dB	Measure ment dBuV/m	Limit dBuV/m	Margin dB	Detector	Comment
1	5715.0000	24.88	41.25	66.13	109.50	-43.37	Peak	
2	5715.0000	14.94	41.25	56.19	109.50	-53.31	AVG	
3	5725.0000	31.73	41.27	73.00	122.30	-49.30	Peak	
4	5725.0000	19.78	41.27	61.05	122.30	-61.25	AVG	
5	5738.8000	53.06	41.28	94.34	122.30	-27.96	AVG	No Limit
6 *	5749.8000	64.24	41.30	105.54	122.30	-16.76	Peak	No Limit

Orthogonal Axis:	X
Test Mode:	UNII-3/TX N40 Mode 5755MHz

Vertical

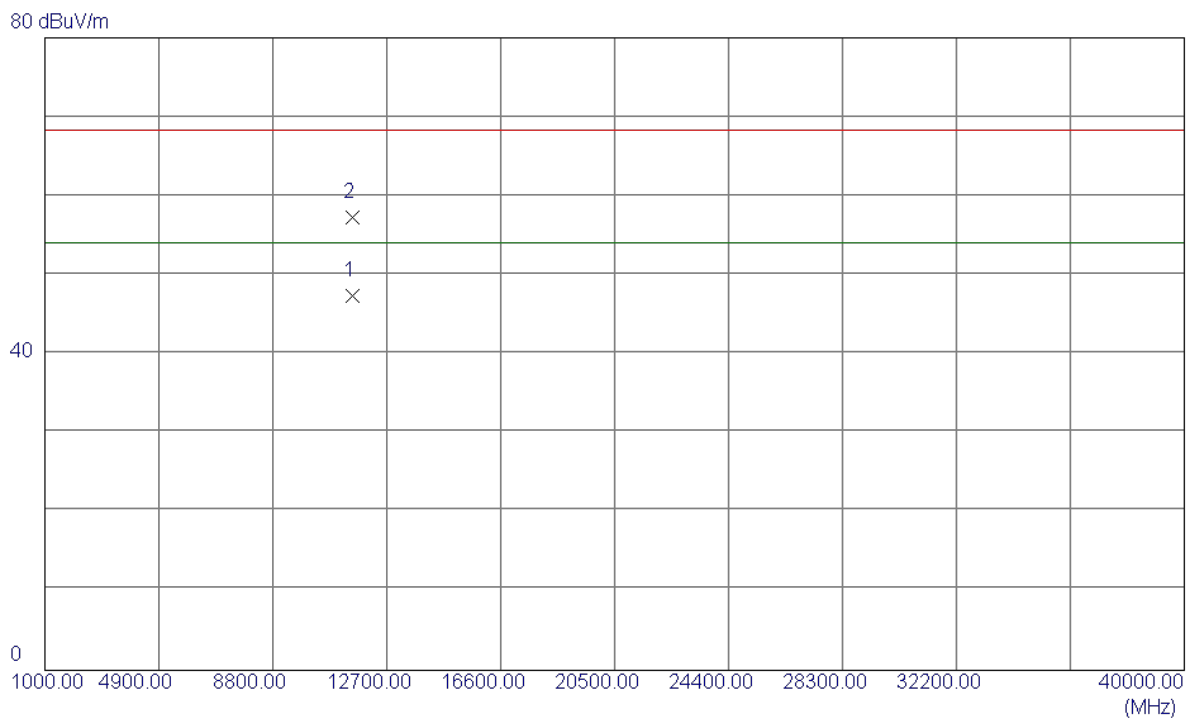

No.	Freq. MHz	Reading Level dBuV/m	Correct Factor dB	Measure ment dBuV/m	Limit dBuV/m	Margin dB	Detector	Comment
1 *	11510.0000	30.39	16.95	47.34	54.00	-6.66	AVG	
2	11510.8000	40.35	16.95	57.30	68.30	-11.00	Peak	

Orthogonal Axis:	X
Test Mode:	UNII-3/TX N40 Mode 5755MHz

Horizontal

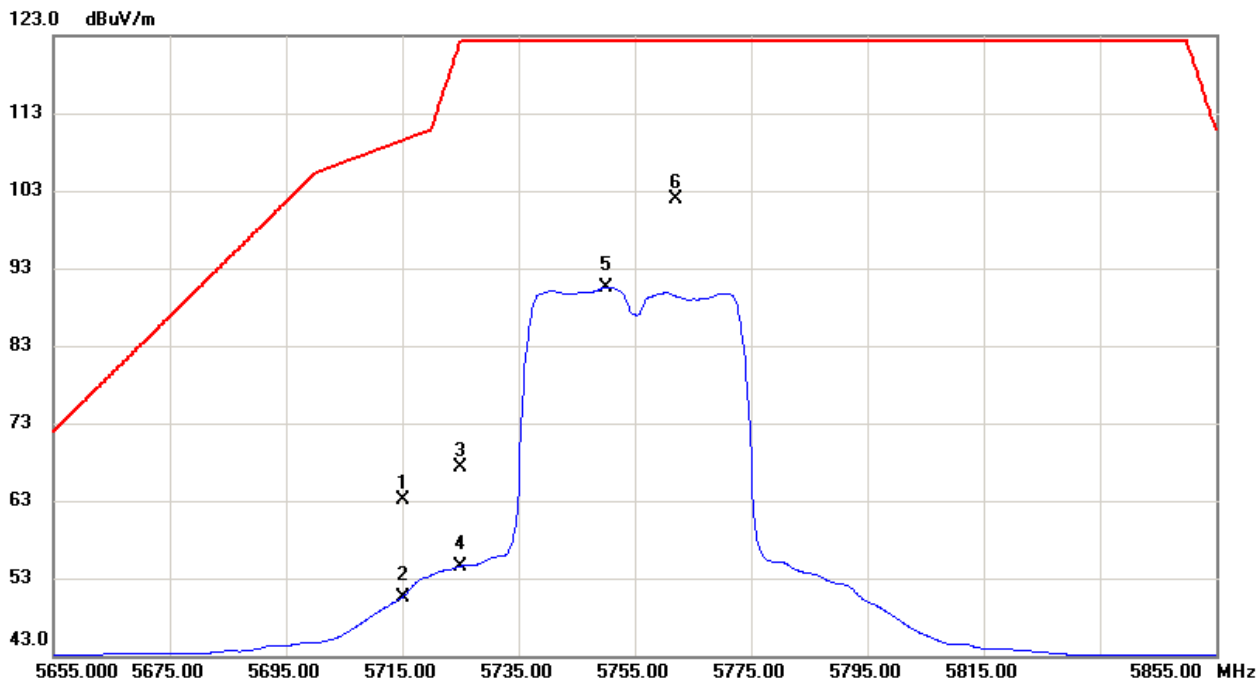

No.	Freq. MHz	Reading Level dBuV/m	Correct Factor dB	Measure ment dBuV/m	Limit dBuV/m	Margin dB	Detector	Comment
1	5715.0000	21.86	41.25	63.11	109.50	-46.39	Peak	
2	5715.0000	9.30	41.25	50.55	109.50	-58.95	AVG	
3	5725.0000	26.07	41.27	67.34	122.30	-54.96	Peak	
4	5725.0000	13.29	41.27	54.56	122.30	-67.74	AVG	
5	5750.2000	49.24	41.30	90.54	122.30	-31.76	AVG	No Limit
6 *	5762.0000	60.53	41.32	101.85	122.30	-20.45	Peak	No Limit

Orthogonal Axis:	X
Test Mode:	UNII-3/TX N40 Mode 5755MHz

Horizontal

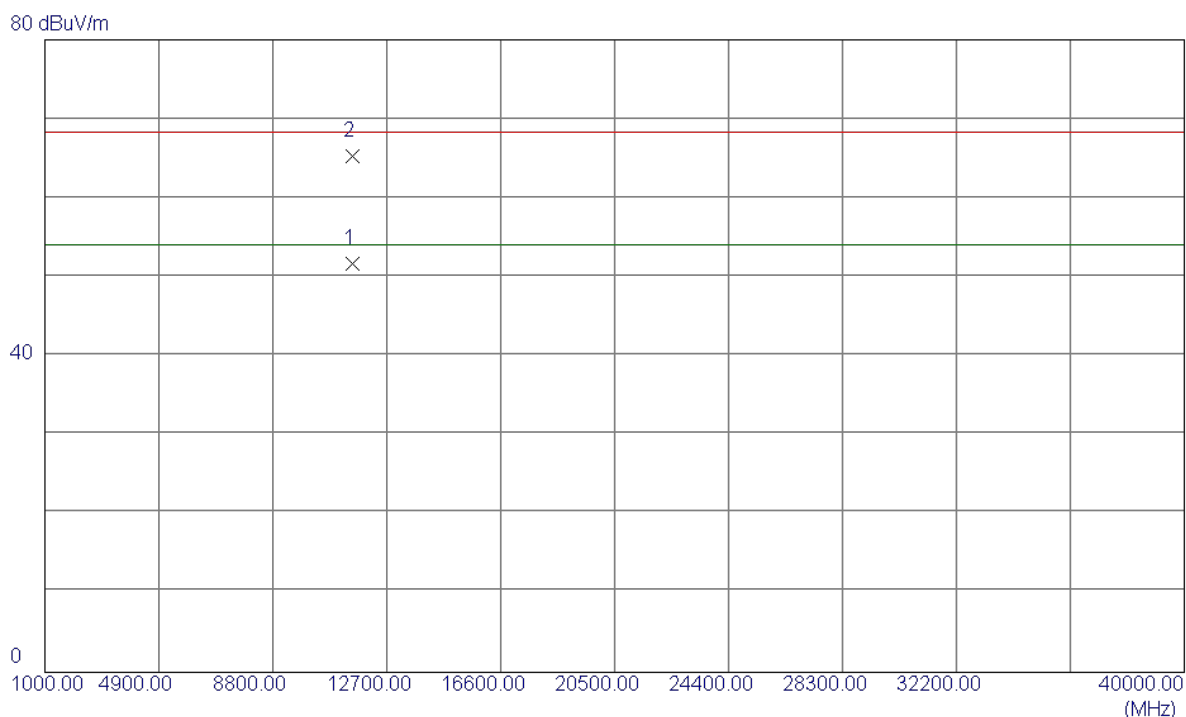

No.	Freq. MHz	Reading Level dBuV/m	Correct Factor dB	Measure ment dBuV/m	Limit dBuV/m	Margin dB	Detector	Comment
1 *	11510.6000	34.71	16.95	51.66	54.00	-2.34	AVG	
2	11511.4000	48.30	16.95	65.25	68.30	-3.05	Peak	

Orthogonal Axis:	X
Test Mode:	UNII-3/TX N40 Mode 5795MHz

Vertical

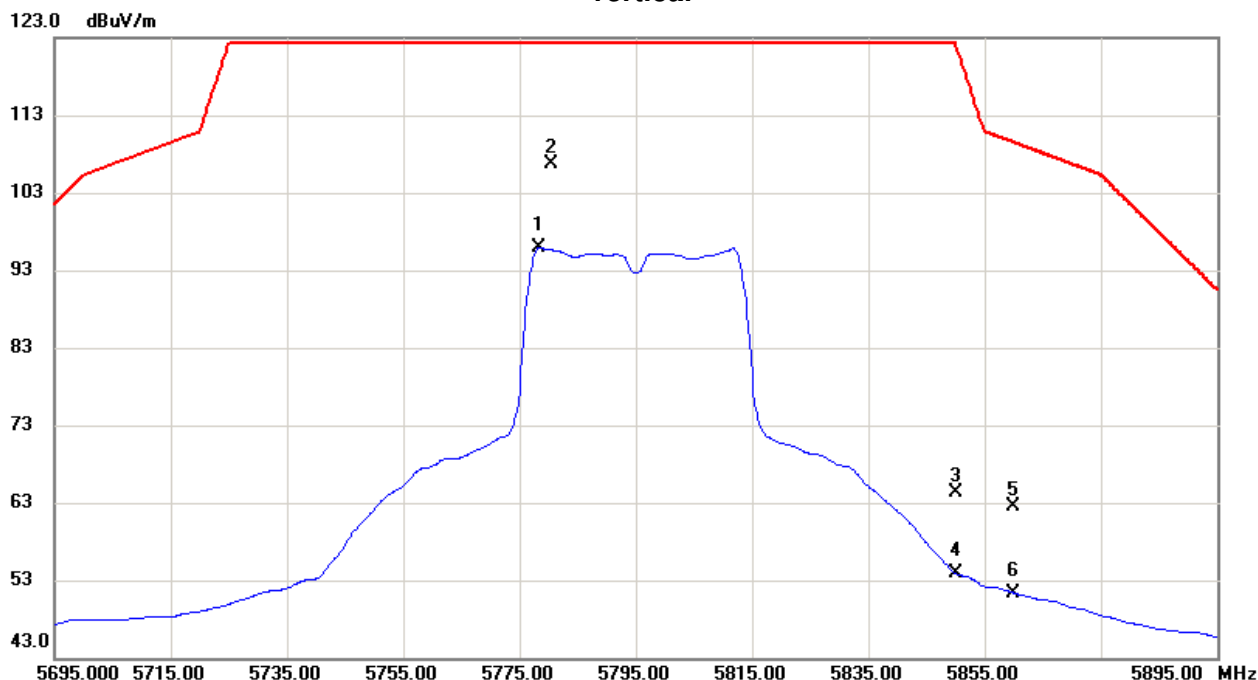

No.	Freq. MHz	Reading Level dBuV/m	Correct Factor dB	Measure ment dBuV/m	Limit dBuV/m	Margin dB	Detector	Comment
1	5778.4000	54.59	41.34	95.93	122.30	-26.37	AVG	No Limit
2 *	5780.4000	65.31	41.34	106.65	122.30	-15.65	Peak	No Limit
3	5850.0000	22.87	41.44	64.31	122.30	-57.99	Peak	
4	5850.0000	12.45	41.44	53.89	122.30	-68.41	AVG	
5	5860.0000	21.14	41.45	62.59	109.50	-46.91	Peak	
6	5860.0000	9.93	41.45	51.38	109.50	-58.12	AVG	

Orthogonal Axis:	X
Test Mode:	UNII-3/TX N40 Mode 5795MHz

Vertical

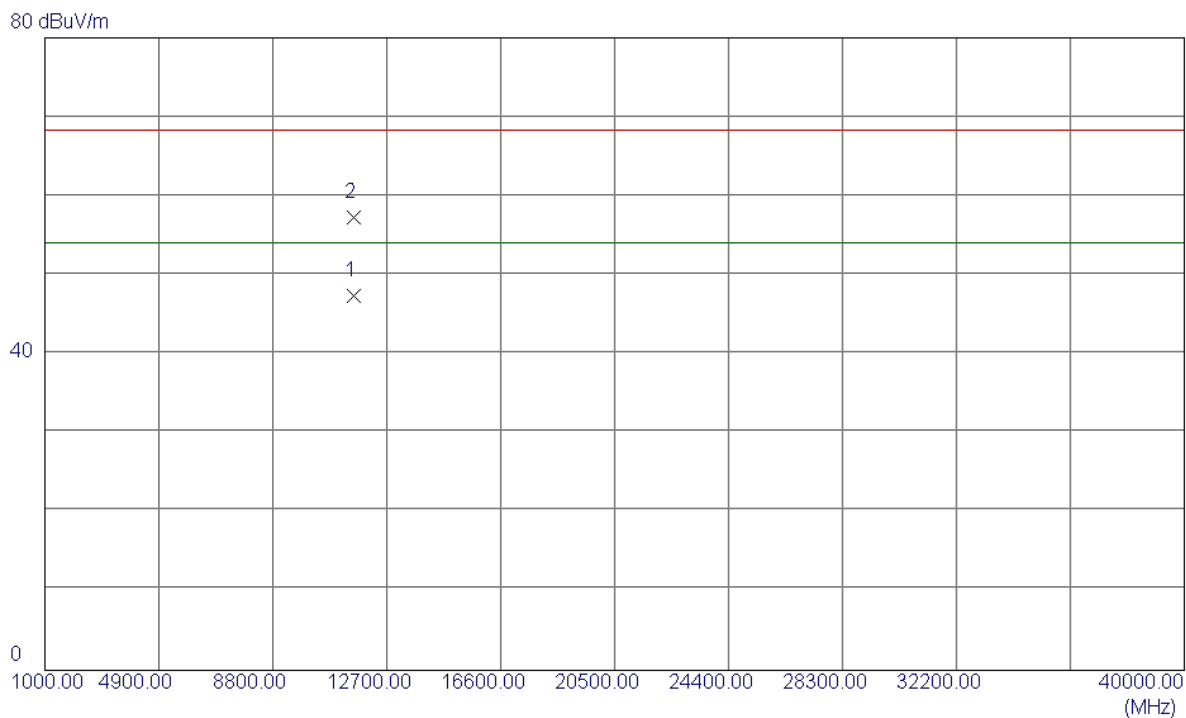

No.	Freq. MHz	Reading Level dBuV/m	Correct Factor dB	Measure ment dBuV/m	Limit dBuV/m	Margin dB	Detector	Comment
1 *	11590.0000	30.34	17.08	47.42	54.00	-6.58	AVG	
2	11590.1000	40.23	17.08	57.31	68.30	-10.99	Peak	

Orthogonal Axis:	X
Test Mode:	UNII-3/TX N40 Mode 5795MHz

Horizontal

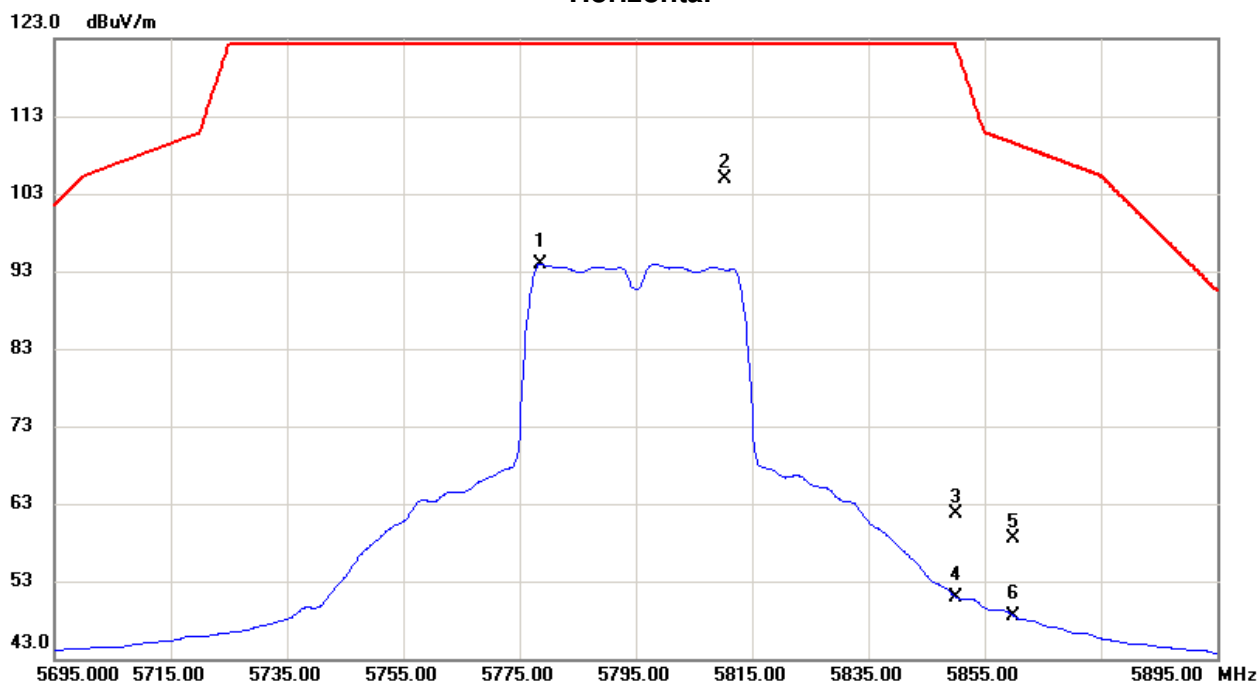

No.	Freq. MHz	Reading Level dBuV/m	Correct Factor dB	Measure ment dBuV/m	Limit dBuV/m	Margin dB	Detector	Comment
1	5778.6000	52.60	41.34	93.94	122.30	-28.36	AVG	No Limit
2 *	5810.4000	63.58	41.38	104.96	122.30	-17.34	Peak	No Limit
3	5850.0000	20.36	41.44	61.80	122.30	-60.50	Peak	
4	5850.0000	9.56	41.44	51.00	122.30	-71.30	AVG	
5	5860.0000	17.03	41.45	58.48	109.50	-51.02	Peak	
6	5860.0000	7.07	41.45	48.52	109.50	-60.98	AVG	

Orthogonal Axis:	X
Test Mode:	UNII-3/TX N40 Mode 5795MHz

Horizontal

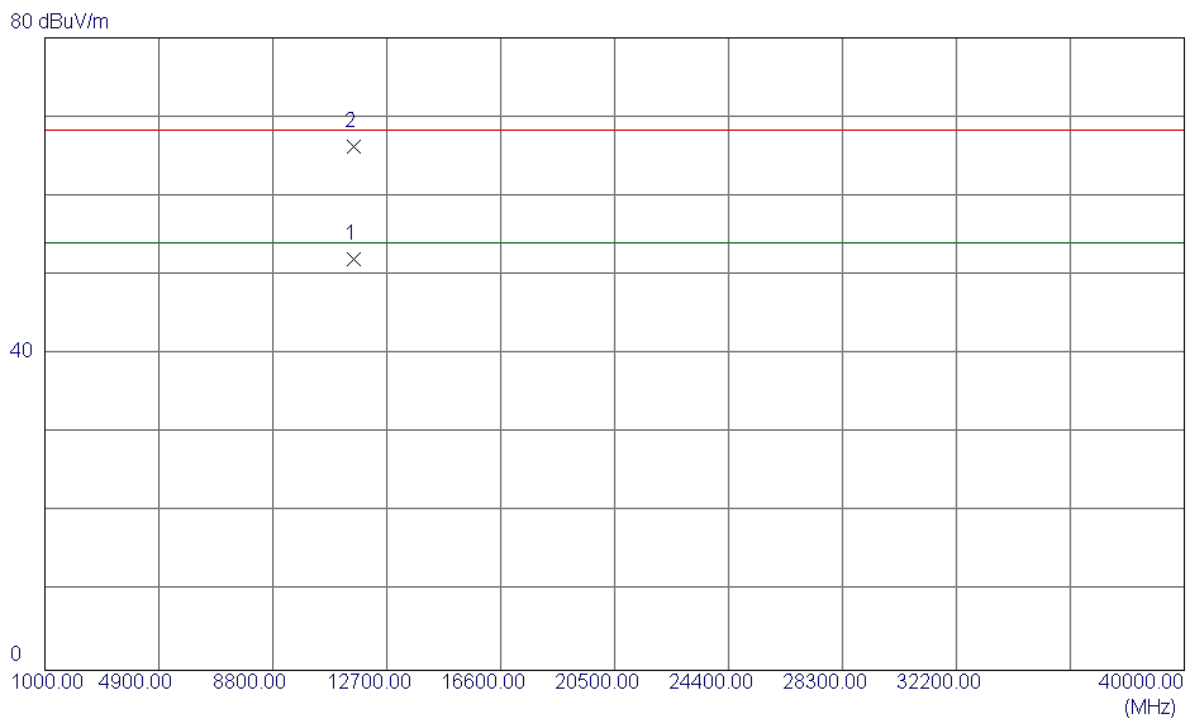

No.	Freq. MHz	Reading Level dBuV/m	Correct Factor dB	Measure ment dBuV/m	Limit dBuV/m	Margin dB	Detector	Comment
1 *	11590.4000	34.90	17.08	51.98	54.00	-2.02	AVG	
2	11591.2000	49.12	17.08	66.20	68.30	-2.10	Peak	

Orthogonal Axis:	X
Test Mode:	UNII-1/ TX AC (VHT20MHz) Mode 5180MHz

Vertical

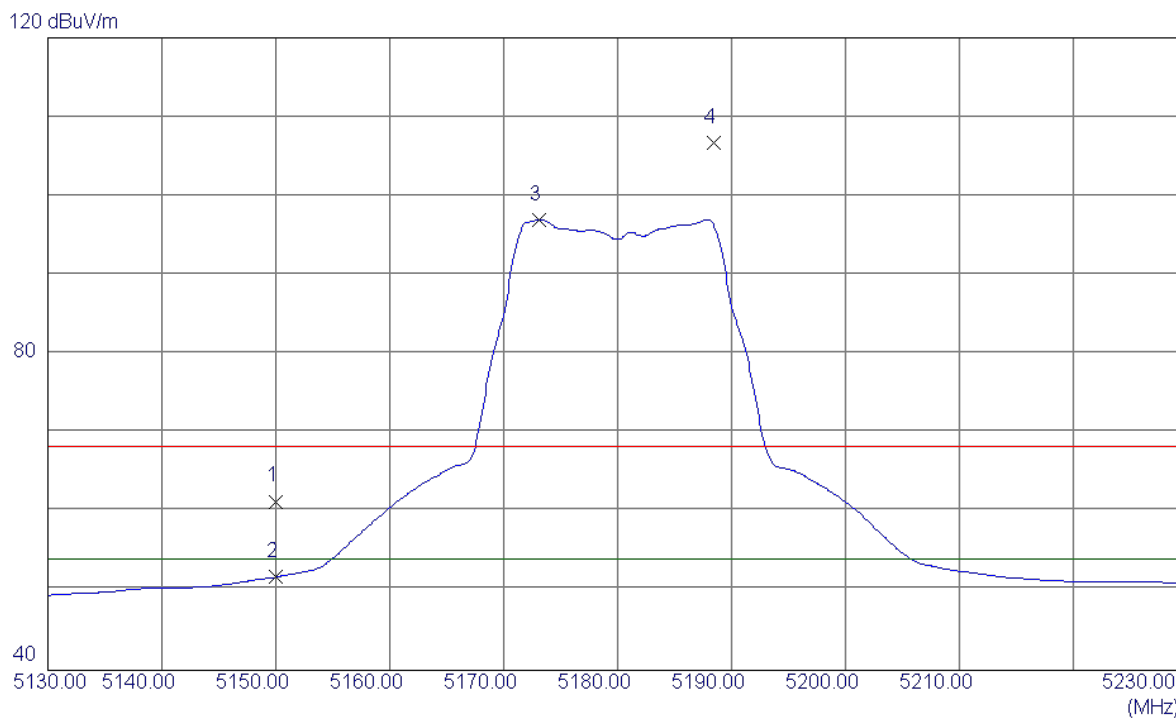

No.	Freq. MHz	Reading Level dBuV/m	Correct Factor dB	Measure ment dBuV/m	Limit dBuV/m	Margin dB	Detector	Comment
1	5150.0000	21.14	40.22	61.36	68.30	-6.94	Peak	
2	5150.0000	11.56	40.22	51.78	54.00	-2.22	AVG	
3 *	5173.1000	56.75	40.27	97.02	54.00	43.02	AVG	No Limit
4	5188.4000	66.37	40.30	106.67	68.30	38.37	Peak	No Limit

Orthogonal Axis:	X
Test Mode:	UNII-1/ TX AC (VHT20MHz) Mode 5180MHz

Vertical

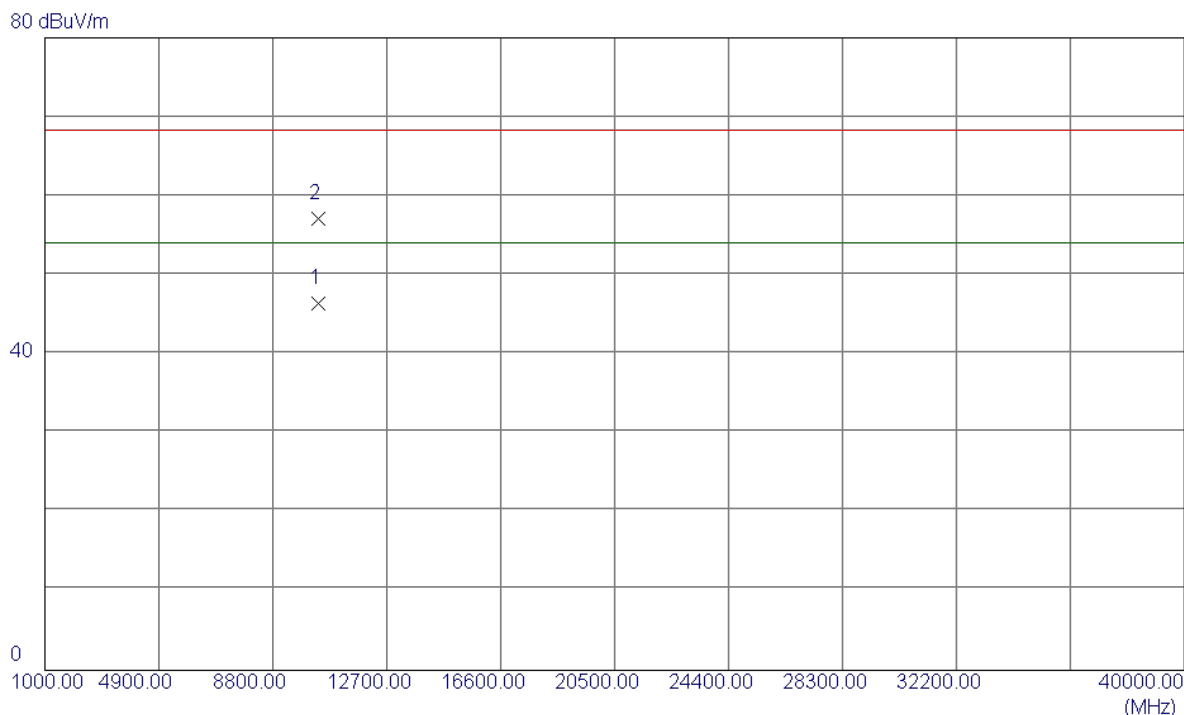

No.	Freq. MHz	Reading Level dBuV/m	Correct Factor dB	Measure ment dBuV/m	Limit dBuV/m	Margin dB	Detector	Comment
1 *	10359.6000	32.49	13.86	46.35	54.00	-7.65	AVG	
2	10359.2000	43.30	13.86	57.16	68.30	-11.14	Peak	

Orthogonal Axis:	X
Test Mode:	UNII-1/ TX AC (VHT20MHz) Mode 5180MHz

Horizontal

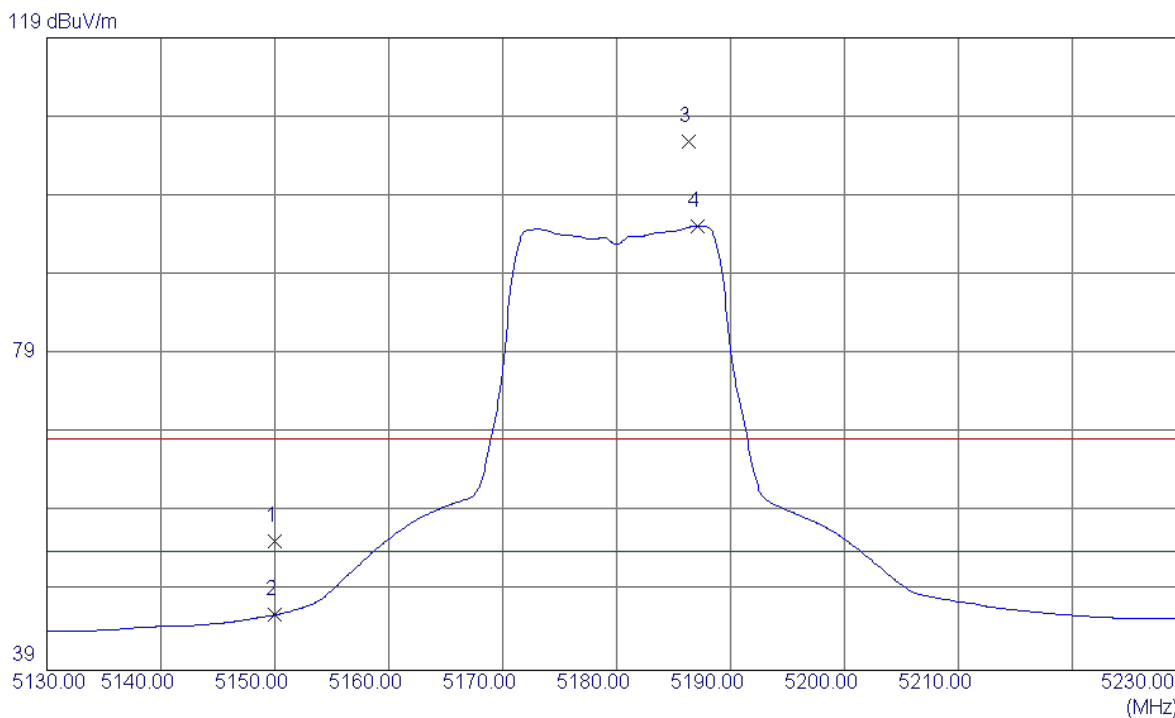

No.	Freq. MHz	Reading Level dBuV/m	Correct Factor dB	Measure ment dBuV/m	Limit dBuV/m	Margin dB	Detector	Comment
1	5150.0000	15.17	40.22	55.39	68.30	-12.91	Peak	
2	5150.0000	5.77	40.22	45.99	54.00	-8.01	AVG	
3	5186.3000	65.62	40.29	105.91	68.30	37.61	Peak	No Limit
4 *	5187.1000	54.90	40.30	95.20	54.00	41.20	AVG	No Limit

Orthogonal Axis:	X
Test Mode:	UNII-1/ TX AC (VHT20MHz) Mode 5180MHz

Horizontal

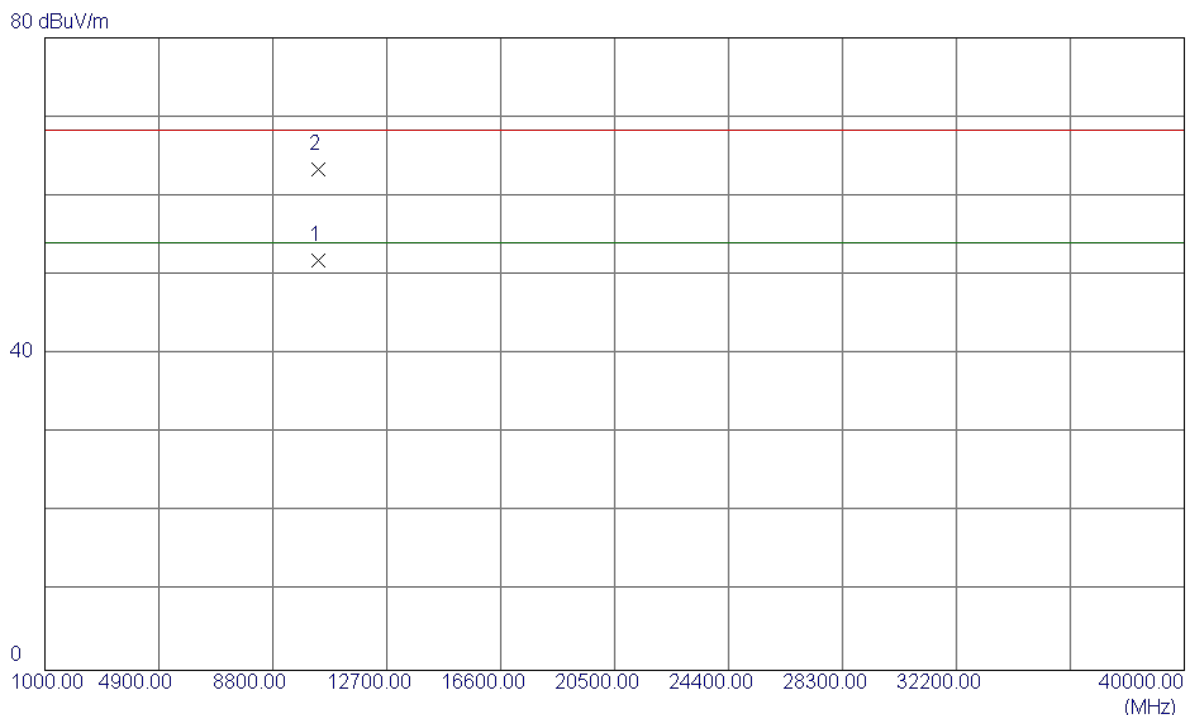

No.	Freq. MHz	Reading Level dBuV/m	Correct Factor dB	Measure ment dBuV/m	Limit dBuV/m	Margin dB	Detector	Comment
1 *	10360.2000	37.92	13.86	51.78	54.00	-2.22	AVG	
2	10365.4000	49.50	13.85	63.35	68.30	-4.95	Peak	

Orthogonal Axis:	X
Test Mode:	UNII-1/ TX AC (VHT20MHz) Mode 5200MHz

Vertical

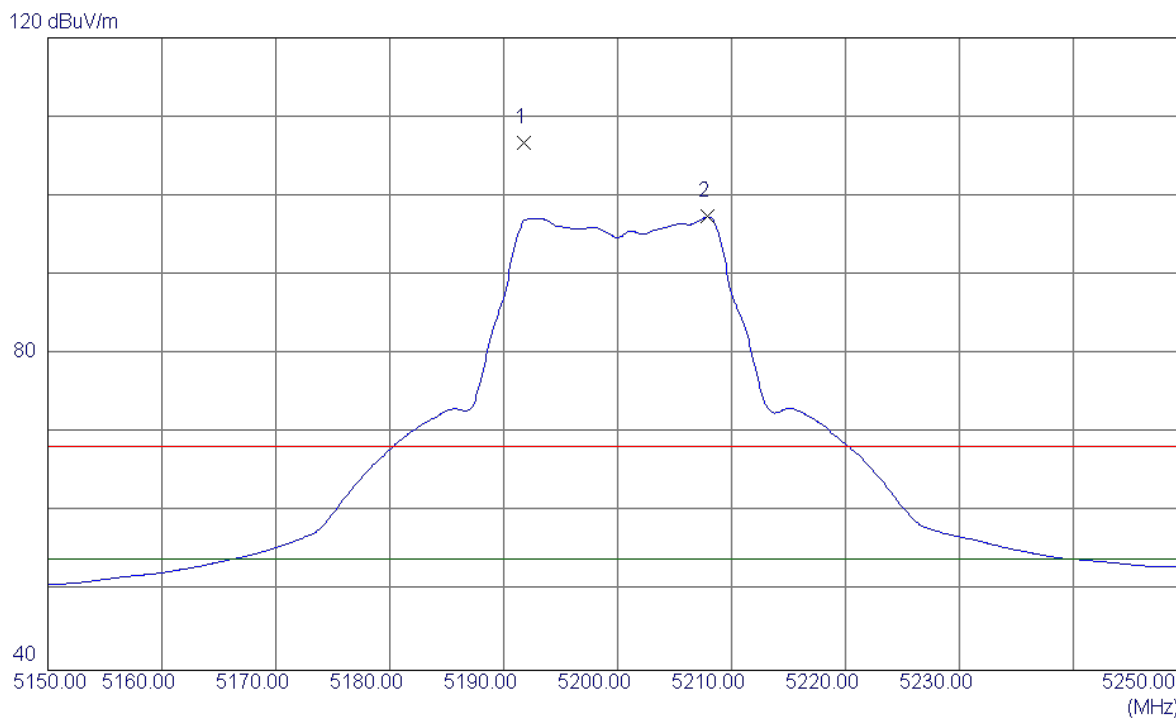

No.	Freq. MHz	Reading Level dBuV/m	Correct Factor dB	Measure ment dBuV/m	Limit dBuV/m	Margin dB	Detector	Comment
1	5191.8000	66.46	40.31	106.77	68.30	38.47	Peak	No Limit
2 *	5207.9000	57.03	40.34	97.37	54.00	43.37	AVG	No Limit

Orthogonal Axis:	X
Test Mode:	UNII-1/ TX AC (VHT20MHz) Mode 5200MHz

Vertical

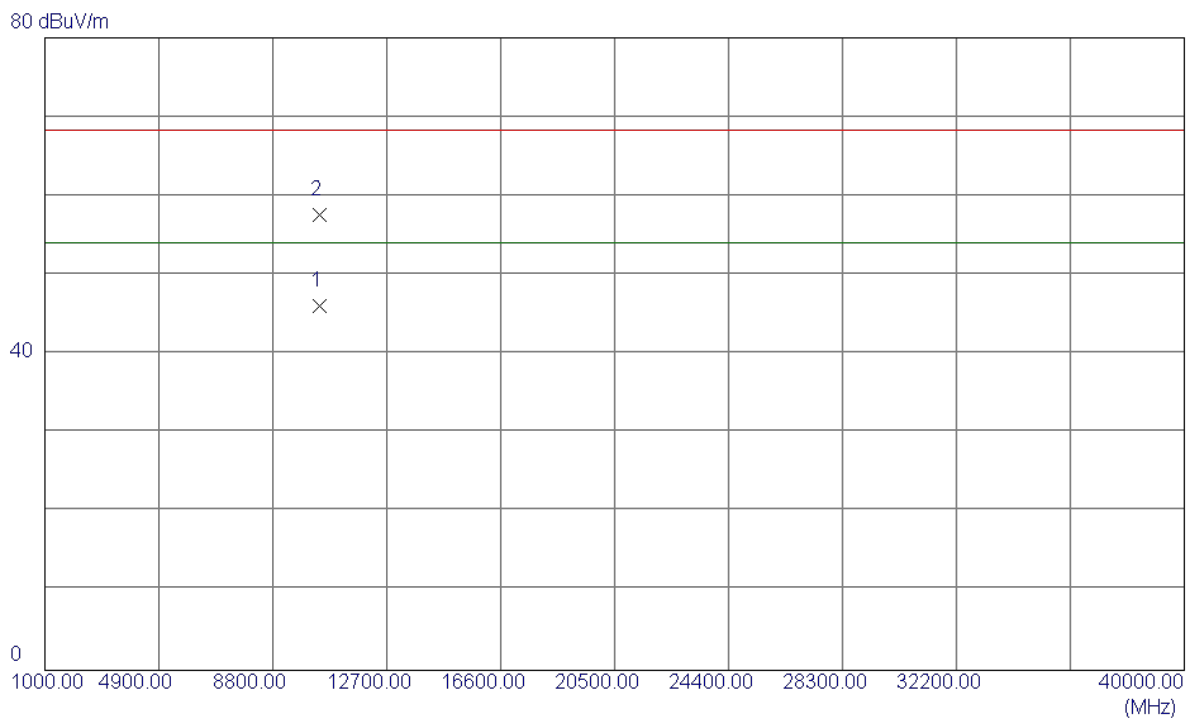

No.	Freq. MHz	Reading Level dBuV/m	Correct Factor dB	Measure ment dBuV/m	Limit dBuV/m	Margin dB	Detector	Comment
1 *	10400.0000	32.31	13.80	46.11	54.00	-7.89	AVG	
2	10399.6000	43.83	13.80	57.63	68.30	-10.67	Peak	

Orthogonal Axis:	X
Test Mode:	UNII-1/ TX AC (VHT20MHz) Mode 5200MHz

Horizontal

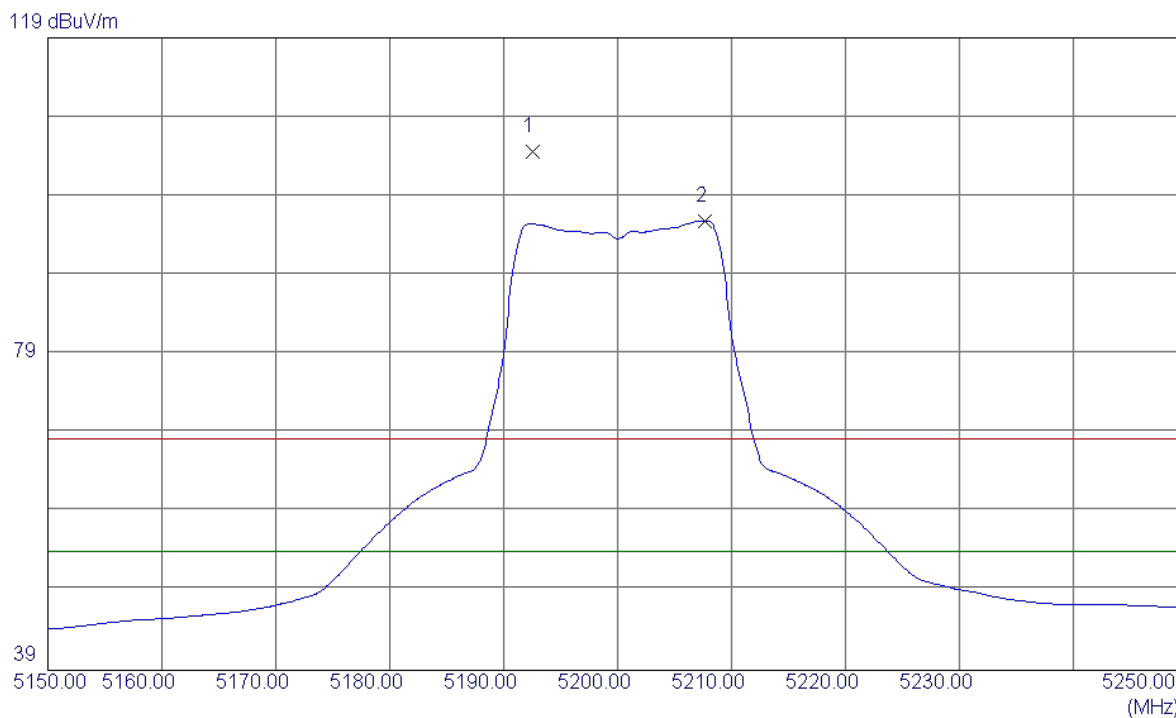

No.	Freq. MHz	Reading Level dBuV/m	Correct Factor dB	Measure ment dBuV/m	Limit dBuV/m	Margin dB	Detector	Comment
1	5192.5000	64.35	40.31	104.66	68.30	36.36	Peak	No Limit
2 *	5207.7000	55.51	40.34	95.85	54.00	41.85	AVG	No Limit

Orthogonal Axis:	X
Test Mode:	UNII-1/ TX AC (VHT20MHz) Mode 5200MHz

Horizontal

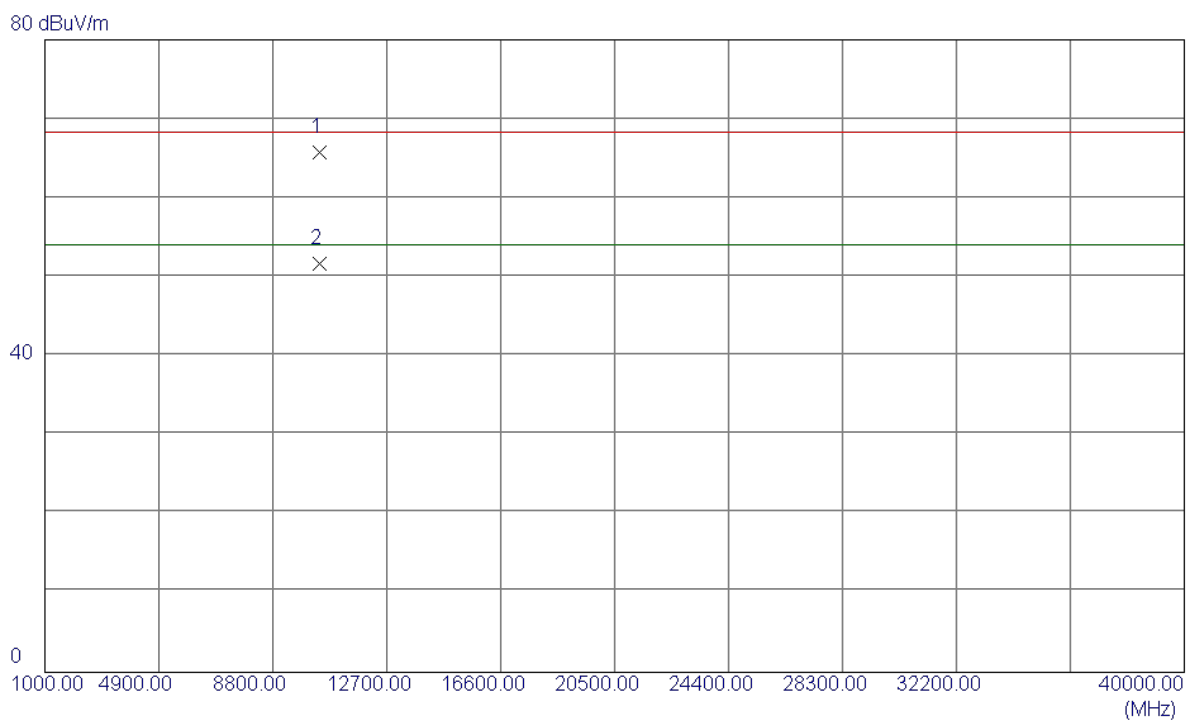

No.	Freq. MHz	Reading Level dBuV/m	Correct Factor dB	Measure ment dBuV/m	Limit dBuV/m	Margin dB	Detector	Comment
1	10395.2000	51.96	13.81	65.77	68.30	-2.53	Peak	
2 *	10400.4000	37.81	13.80	51.61	54.00	-2.39	AVG	

Orthogonal Axis:	X
Test Mode:	UNII-1/ TX AC (VHT20MHz) Mode 5240MHz

Vertical

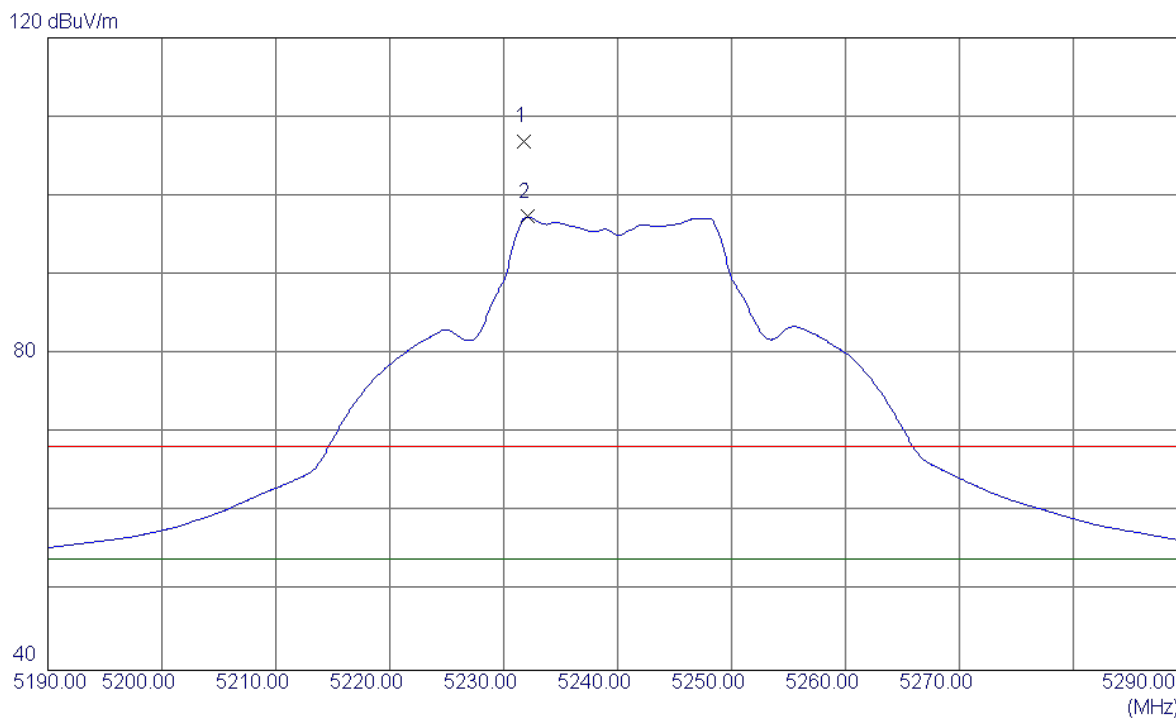

No.	Freq. MHz	Reading Level dBuV/m	Correct Factor dB	Measure ment dBuV/m	Limit dBuV/m	Margin dB	Detector	Comment
1	5231.8000	66.43	40.39	106.82	68.30	38.52	Peak	No Limit
2 *	5232.1000	56.97	40.39	97.36	54.00	43.36	AVG	No Limit

Orthogonal Axis:	X
Test Mode:	UNII-1/ TX AC (VHT20MHz) Mode 5240MHz

Vertical

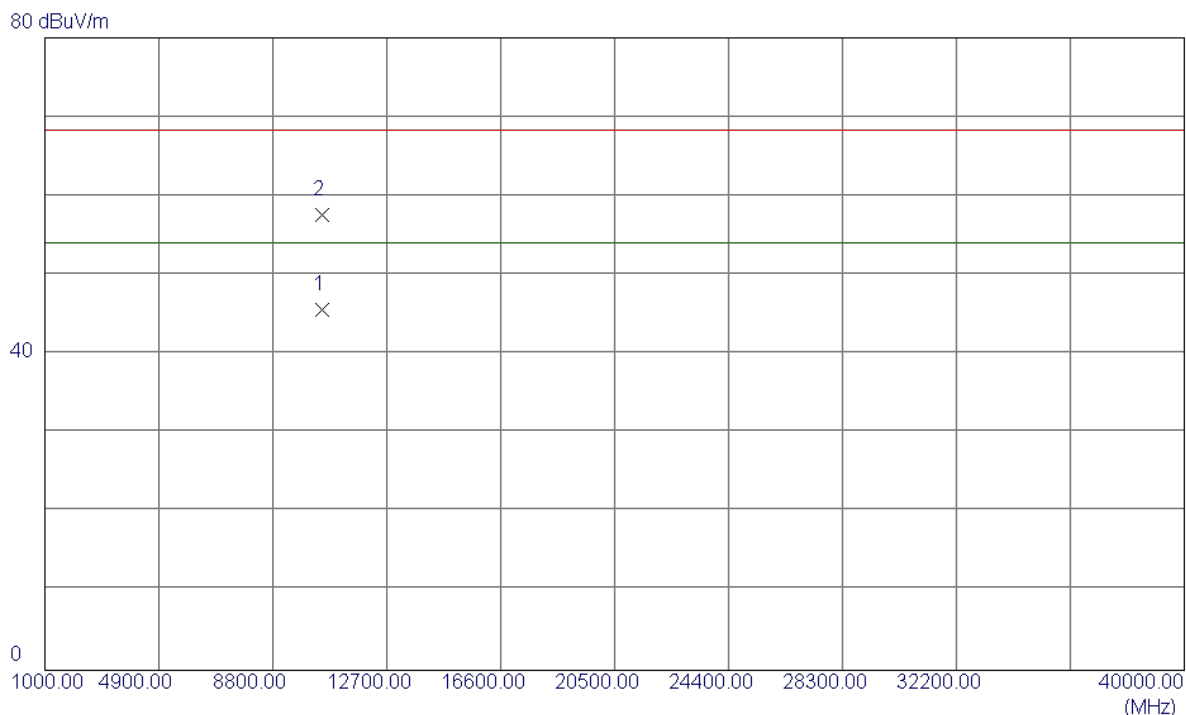

No.	Freq. MHz	Reading Level dBuV/m	Correct Factor dB	Measure ment dBuV/m	Limit dBuV/m	Margin dB	Detector	Comment
1 *	10479.6000	31.91	13.69	45.60	54.00	-8.40	AVG	
2	10482.4000	43.98	13.69	57.67	68.30	-10.63	Peak	

Orthogonal Axis:	X
Test Mode:	UNII-1/ TX AC (VHT20MHz) Mode 5240MHz

Horizontal

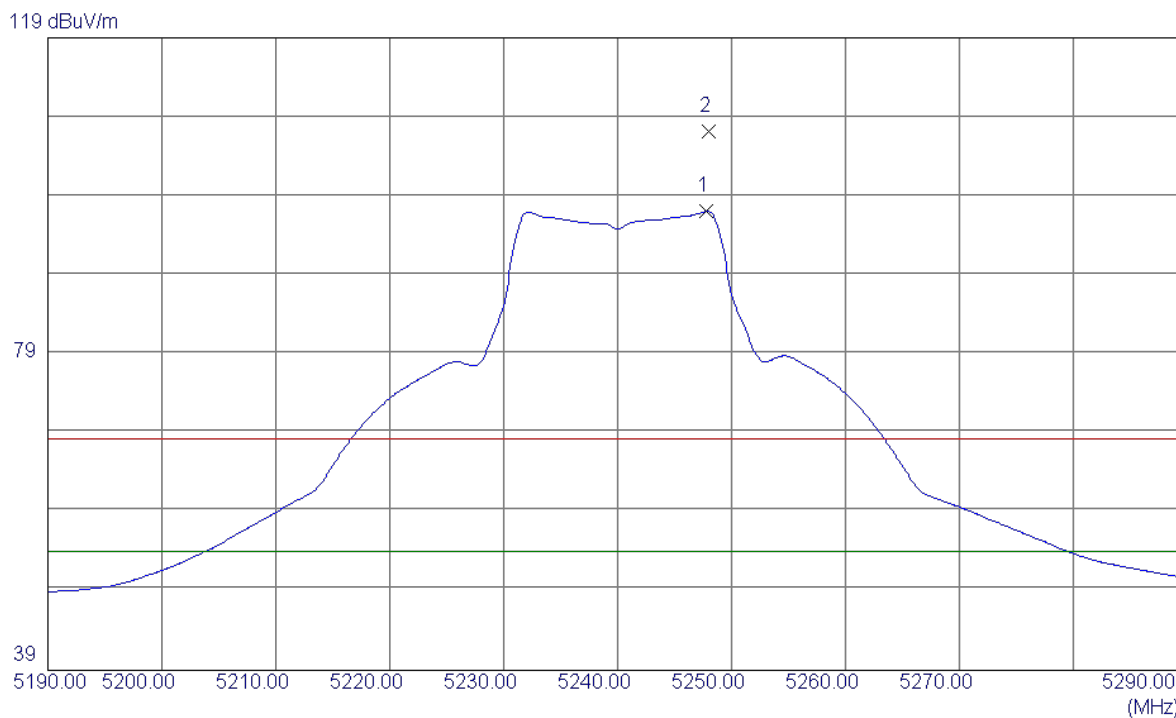

No.	Freq. MHz	Reading Level dBuV/m	Correct Factor dB	Measure ment dBuV/m	Limit dBuV/m	Margin dB	Detector	Comment
1 *	5247.8000	56.60	40.43	97.03	54.00	43.03	AVG	No Limit
2	5248.0000	66.67	40.43	107.10	68.30	38.80	Peak	No Limit

Orthogonal Axis:	X
Test Mode:	UNII-1/ TX AC (VHT20MHz) Mode 5240MHz

Horizontal

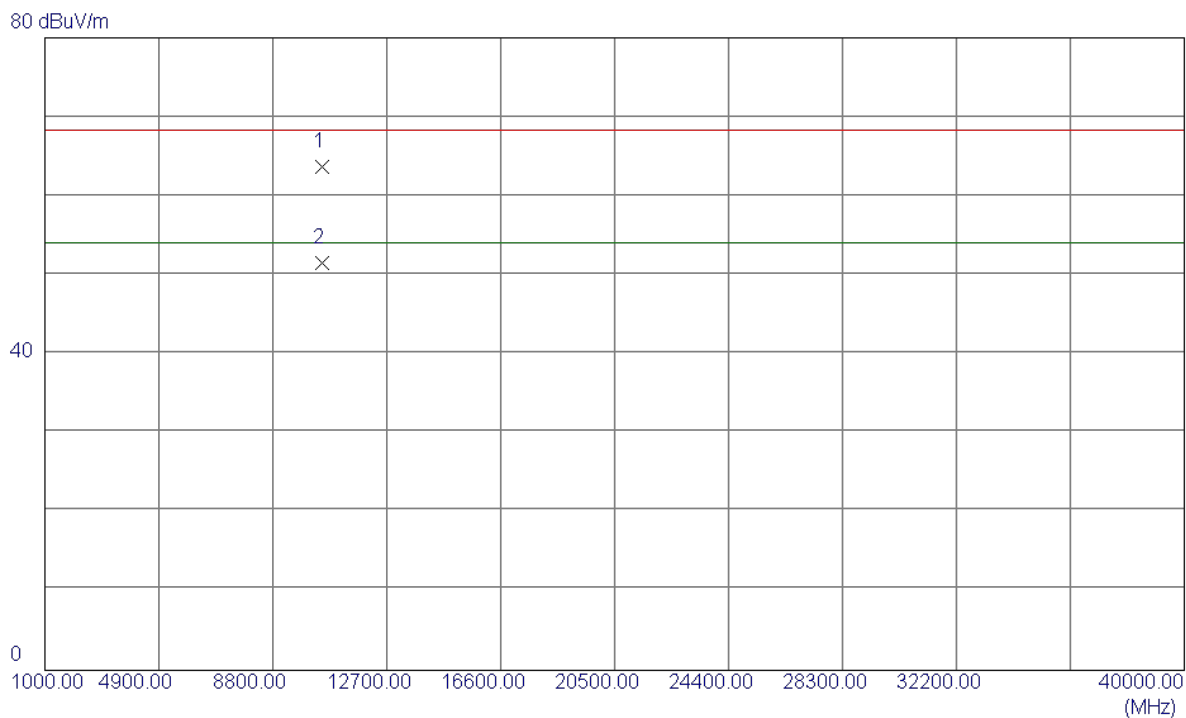

No.	Freq. MHz	Reading Level dBuV/m	Correct Factor dB	Measure ment dBuV/m	Limit dBuV/m	Margin dB	Detector	Comment
1	10475.0000	50.02	13.70	63.72	68.30	-4.58	Peak	
2 *	10480.2000	37.79	13.69	51.48	54.00	-2.52	AVG	

Orthogonal Axis:	X
Test Mode:	UNII-1/ TX AC (VHT40MHz) Mode 5190MHz

Vertical

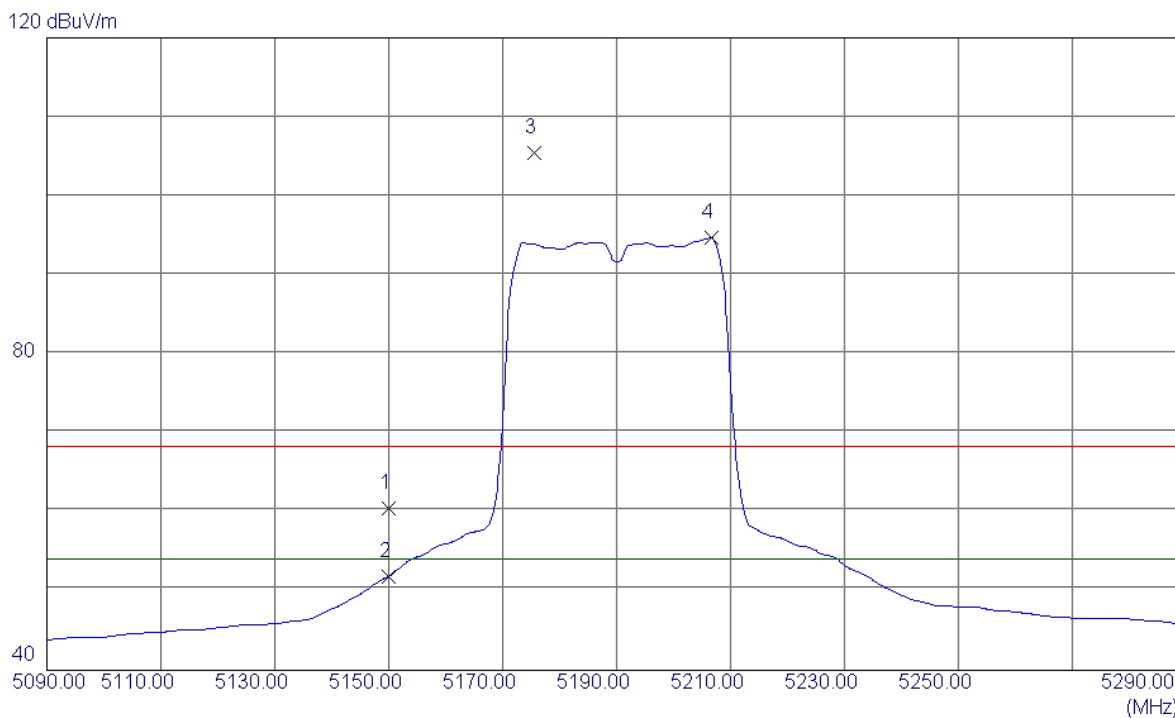

No.	Freq. MHz	Reading Level dBuV/m	Correct Factor dB	Measure ment dBuV/m	Limit dBuV/m	Margin dB	Detector	Comment
1	5150.0000	20.26	40.22	60.48	68.30	-7.82	Peak	
2	5150.0000	11.69	40.22	51.91	54.00	-2.09	AVG	
3	5175.6000	65.22	40.27	105.49	68.30	37.19	Peak	No Limit
4 *	5206.6000	54.39	40.34	94.73	54.00	40.73	AVG	No Limit

Orthogonal Axis:	X
Test Mode:	UNII-1/ TX AC (VHT40MHz) Mode 5190MHz

Vertical

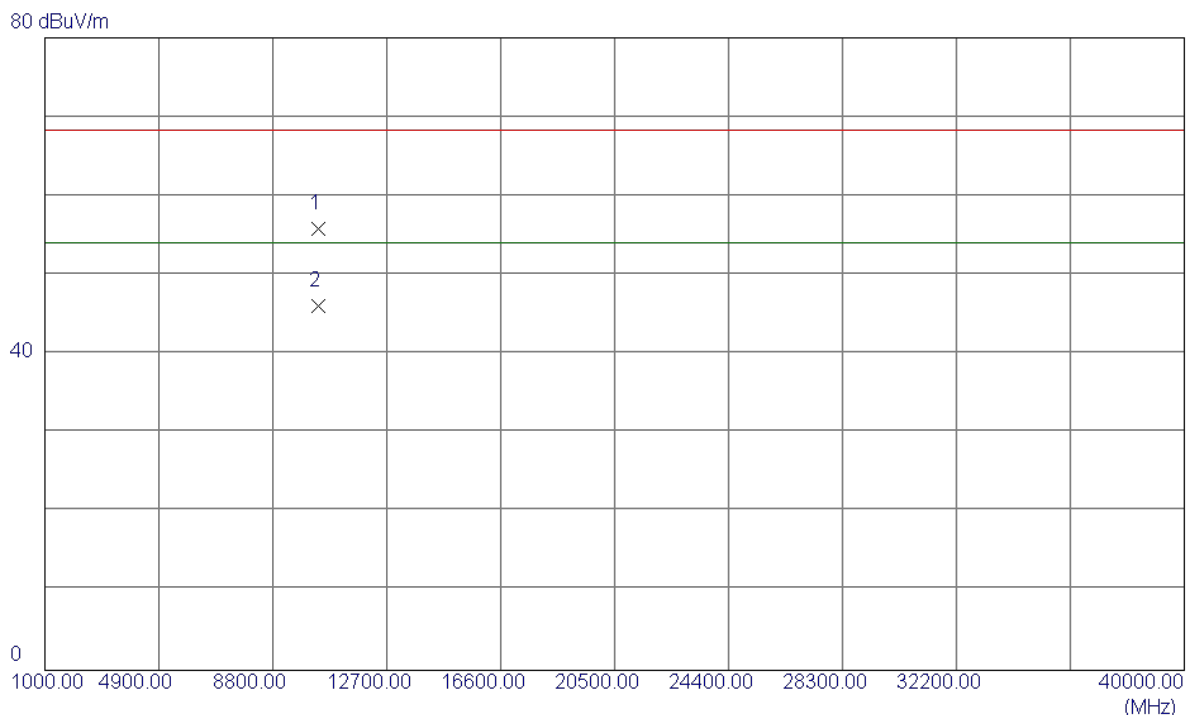

No.	Freq. MHz	Reading Level dBuV/m	Correct Factor dB	Measure ment dBuV/m	Limit dBuV/m	Margin dB	Detector	Comment
1	10379.8000	42.07	13.83	55.90	68.30	-12.40	Peak	
2 *	10379.9800	32.19	13.83	46.02	54.00	-7.98	AVG	

Orthogonal Axis:	X
Test Mode:	UNII-1/ TX AC (VHT40MHz) Mode 5190MHz

Horizontal

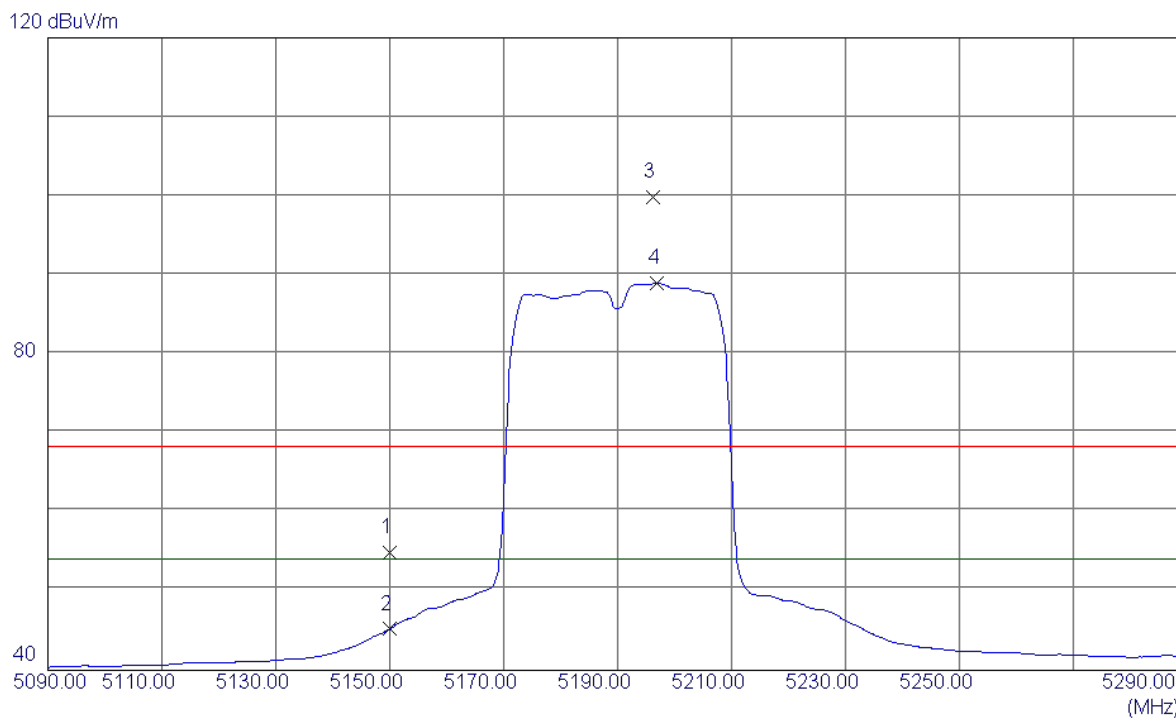

No.	Freq. MHz	Reading Level dBuV/m	Correct Factor dB	Measure ment dBuV/m	Limit dBuV/m	Margin dB	Detector	Comment
1	5150.0000	14.73	40.22	54.95	68.30	-13.35	Peak	
2	5150.0000	4.98	40.22	45.20	54.00	-8.80	AVG	
3	5196.2000	59.52	40.32	99.84	68.30	31.54	Peak	No Limit
4 *	5197.0000	48.69	40.32	89.01	54.00	35.01	AVG	No Limit

Orthogonal Axis:	X
Test Mode:	UNII-1/ TX AC (VHT40MHz) Mode 5190MHz

Horizontal

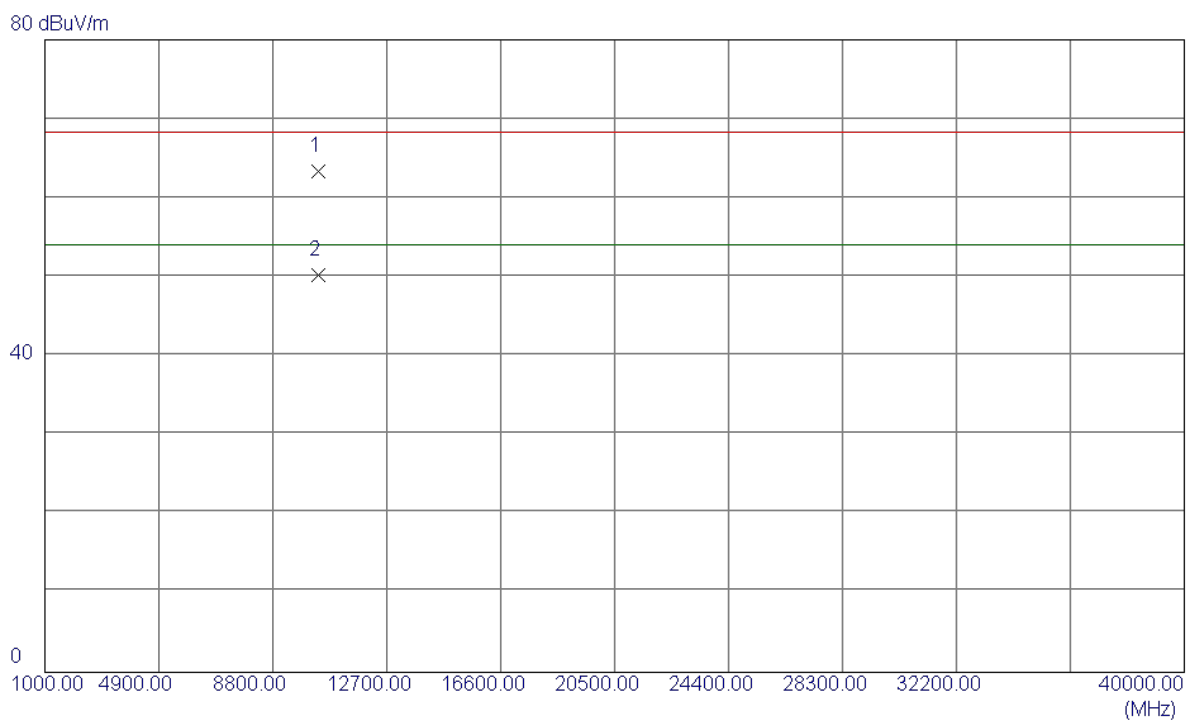

No.	Freq. MHz	Reading Level dBuV/m	Correct Factor dB	Measure ment dBuV/m	Limit dBuV/m	Margin dB	Detector	Comment
1	10380.2000	49.48	13.83	63.31	68.30	-4.99	Peak	
2 *	10380.9000	36.47	13.83	50.30	54.00	-3.70	AVG	

Orthogonal Axis:	X
Test Mode:	UNII-1/ TX AC (VHT40MHz) Mode 5230MHz

Vertical

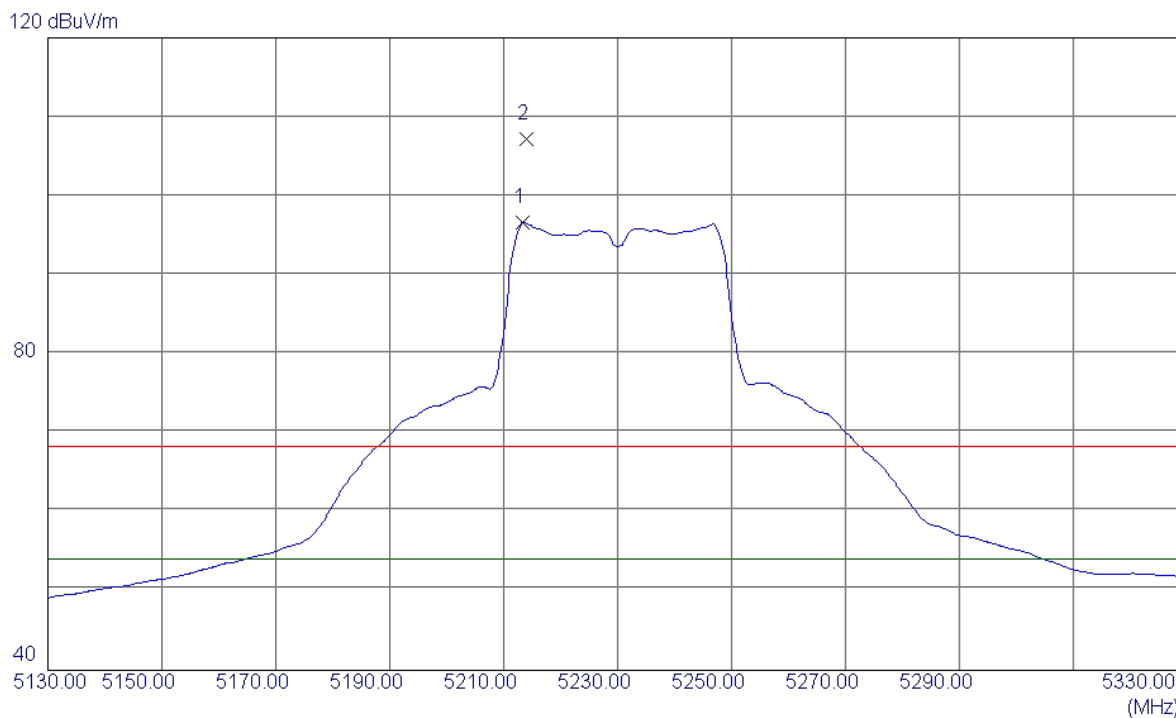

No.	Freq. MHz	Reading Level dBuV/m	Correct Factor dB	Measure ment dBuV/m	Limit dBuV/m	Margin dB	Detector	Comment
1 *	5213.4000	56.29	40.35	96.64	54.00	42.64	AVG	No Limit
2	5214.0000	66.88	40.35	107.23	68.30	38.93	Peak	No Limit

Orthogonal Axis:	X
Test Mode:	UNII-1/ TX AC (VHT40MHz) Mode 5230MHz

Vertical

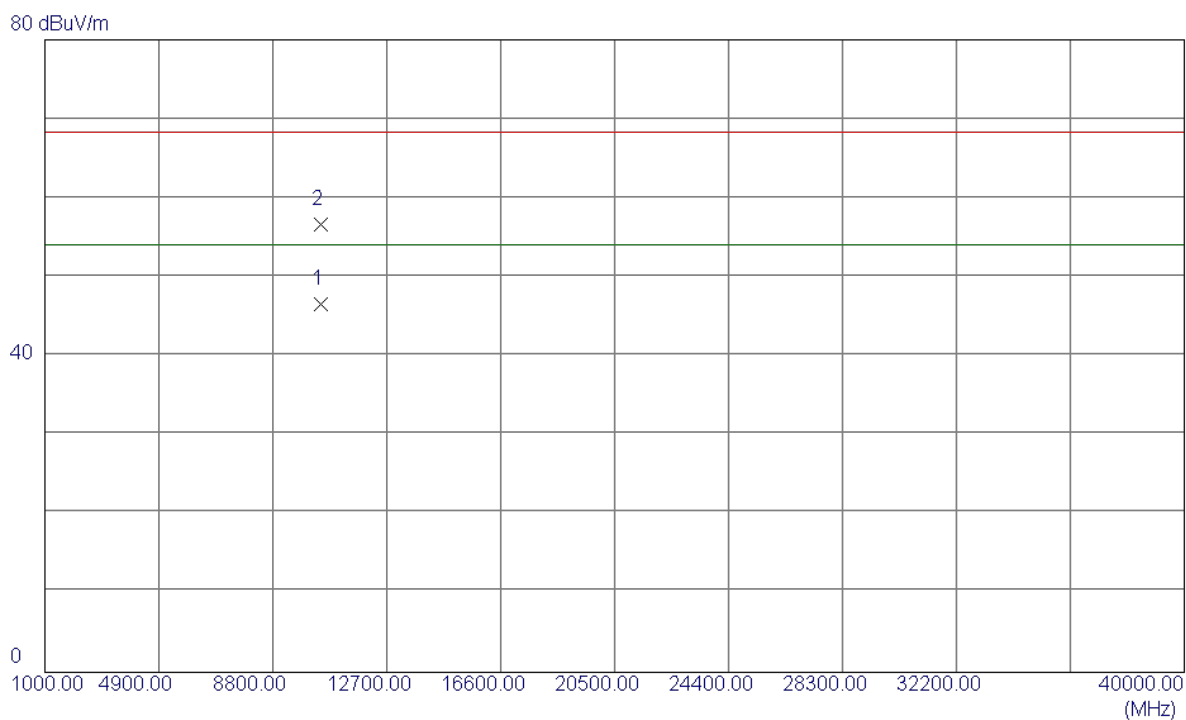

No.	Freq. MHz	Reading Level dBuV/m	Correct Factor dB	Measure ment dBuV/m	Limit dBuV/m	Margin dB	Detector	Comment
1 *	10459.9800	32.86	13.72	46.58	54.00	-7.42	AVG	
2	10460.2400	42.86	13.72	56.58	68.30	-11.72	Peak	

Orthogonal Axis:	X
Test Mode:	UNII-1/ TX AC (VHT40MHz) Mode 5230MHz

Horizontal

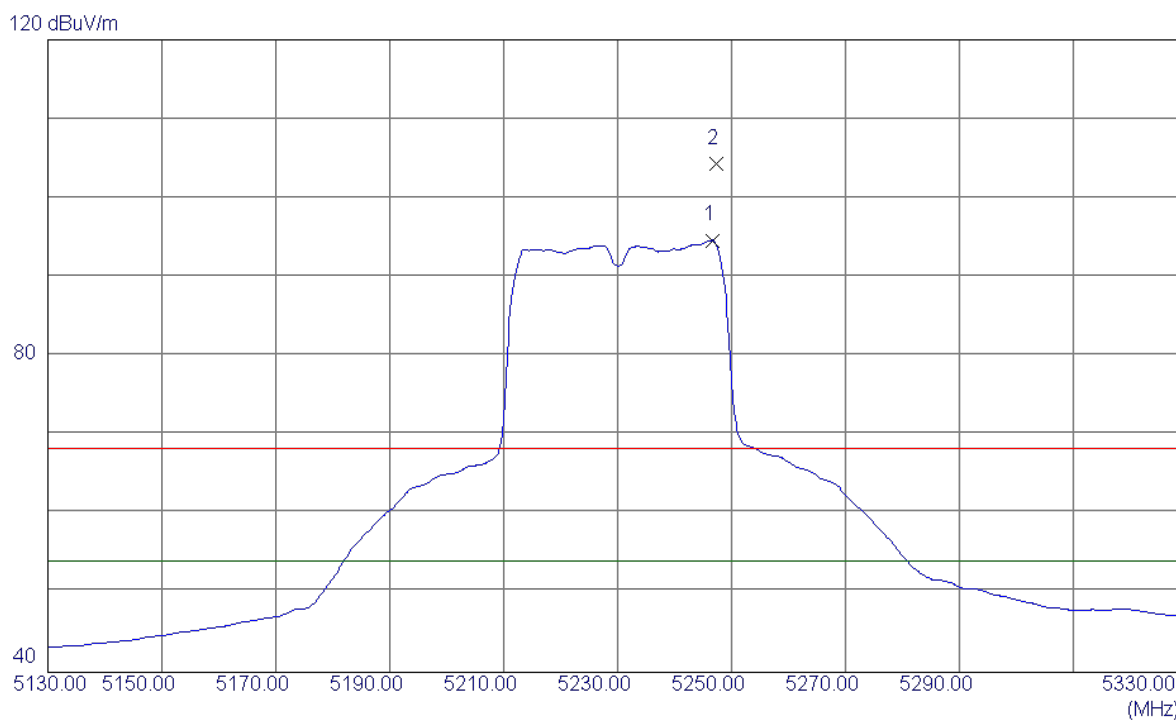

No.	Freq. MHz	Reading Level dBuV/m	Correct Factor dB	Measure ment dBuV/m	Limit dBuV/m	Margin dB	Detector	Comment
1 *	5246.6000	54.22	40.42	94.64	54.00	40.64	AVG	No Limit
2	5247.4000	63.94	40.42	104.36	68.30	36.06	Peak	No Limit

Orthogonal Axis:	X
Test Mode:	UNII-1/ TX AC (VHT40MHz) Mode 5230MHz

Horizontal

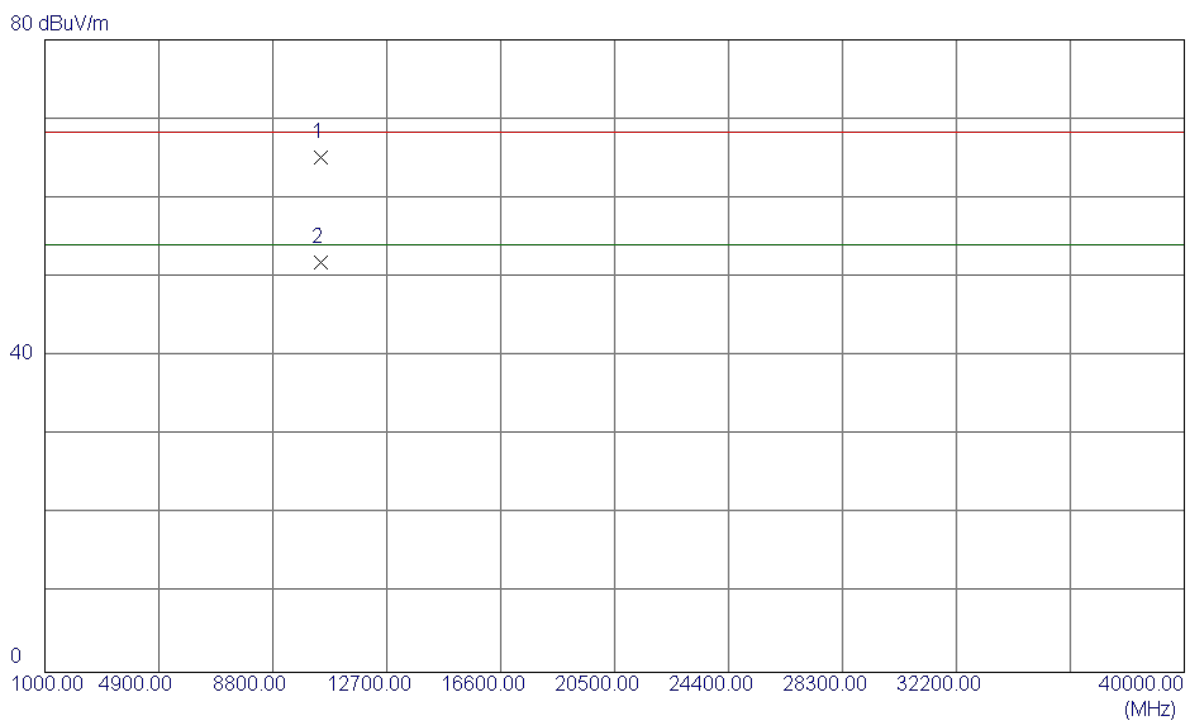

No.	Freq. MHz	Reading Level dBuV/m	Correct Factor dB	Measure ment dBuV/m	Limit dBuV/m	Margin dB	Detector	Comment
1	10455.6000	51.36	13.73	65.09	68.30	-3.21	Peak	
2 *	10460.8000	38.19	13.72	51.91	54.00	-2.09	AVG	

Orthogonal Axis:	X
Test Mode:	UNII-1/ TX AC(VHT80) Mode 5210MHz

Vertical

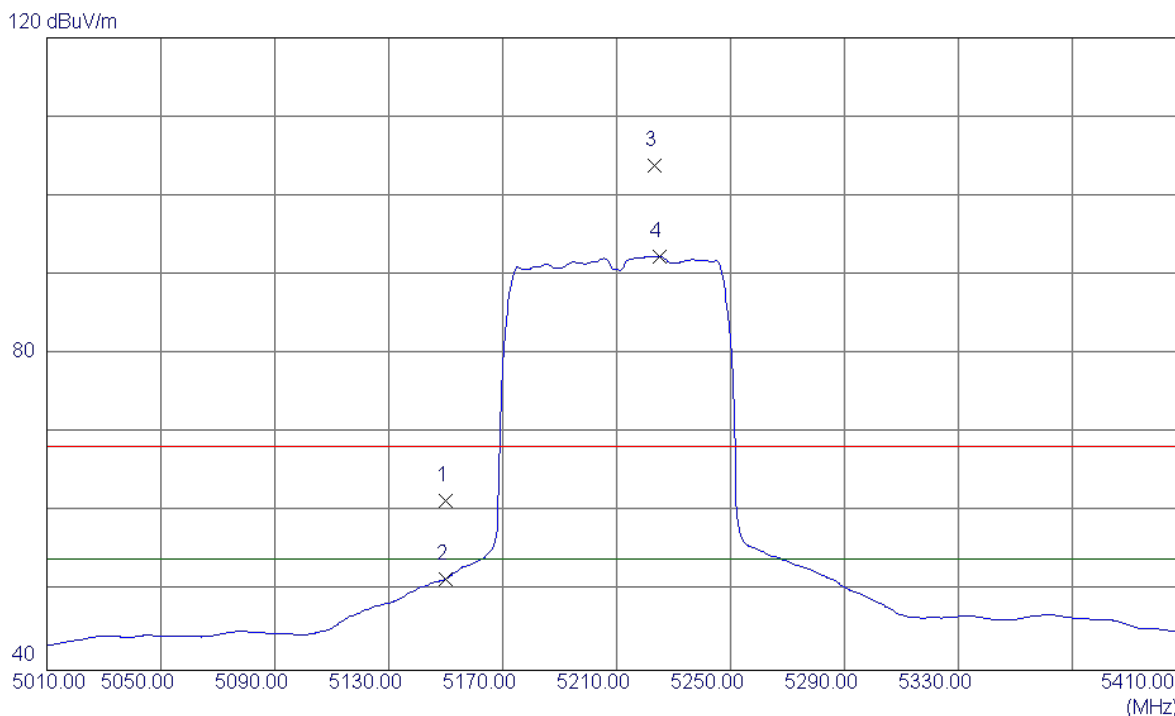

No.	Freq. MHz	Reading Level dBuV/m	Correct Factor dB	Measure ment dBuV/m	Limit dBuV/m	Margin dB	Detector	Comment
1	5150.0000	21.19	40.22	61.41	68.30	-6.89	Peak	
2	5150.0000	11.34	40.22	51.56	54.00	-2.44	AVG	
3	5223.2000	63.47	40.37	103.84	68.30	35.54	Peak	No Limit
4 *	5225.2000	51.96	40.38	92.34	54.00	38.34	AVG	No Limit

Orthogonal Axis:	X
Test Mode:	UNII-1/ TX AC(VHT80) Mode 5210MHz

Vertical

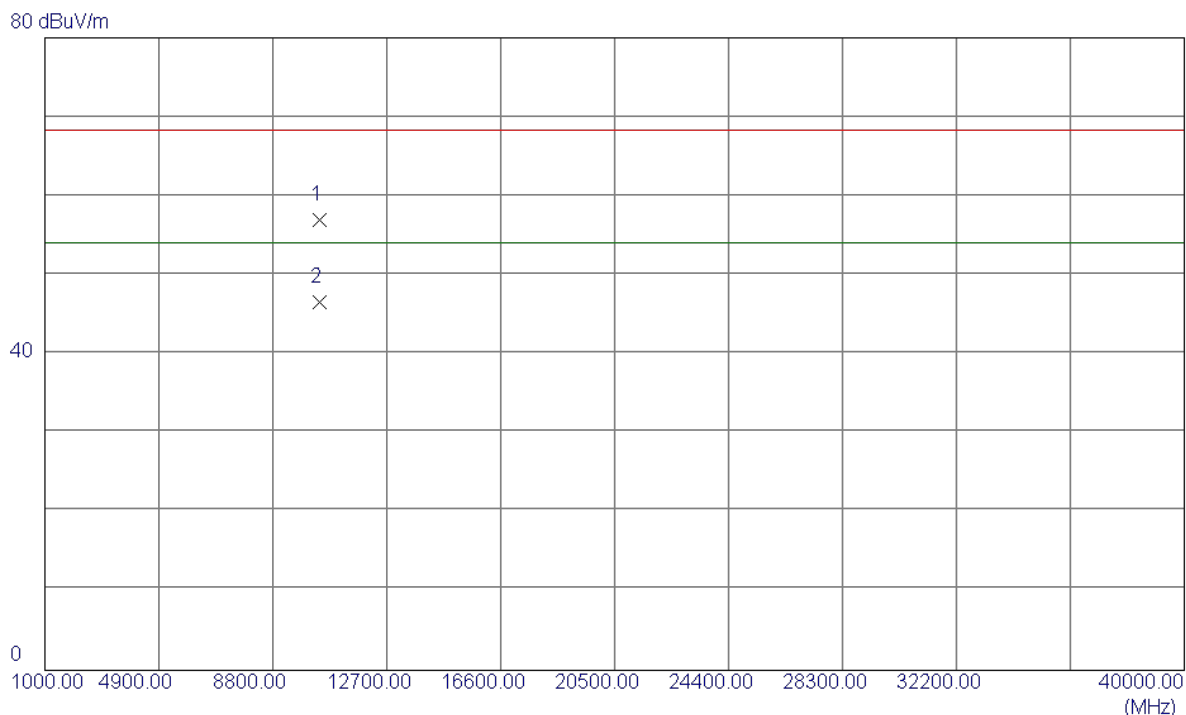

No.	Freq. MHz	Reading Level dBuV/m	Correct Factor dB	Measure ment dBuV/m	Limit dBuV/m	Margin dB	Detector	Comment
1	10419.8750	43.20	13.77	56.97	68.30	-11.33	Peak	
2 *	10419.9700	32.85	13.77	46.62	54.00	-7.38	AVG	

Orthogonal Axis:	X
Test Mode:	UNII-1/ TX AC(VHT80) Mode 5210MHz

Horizontal

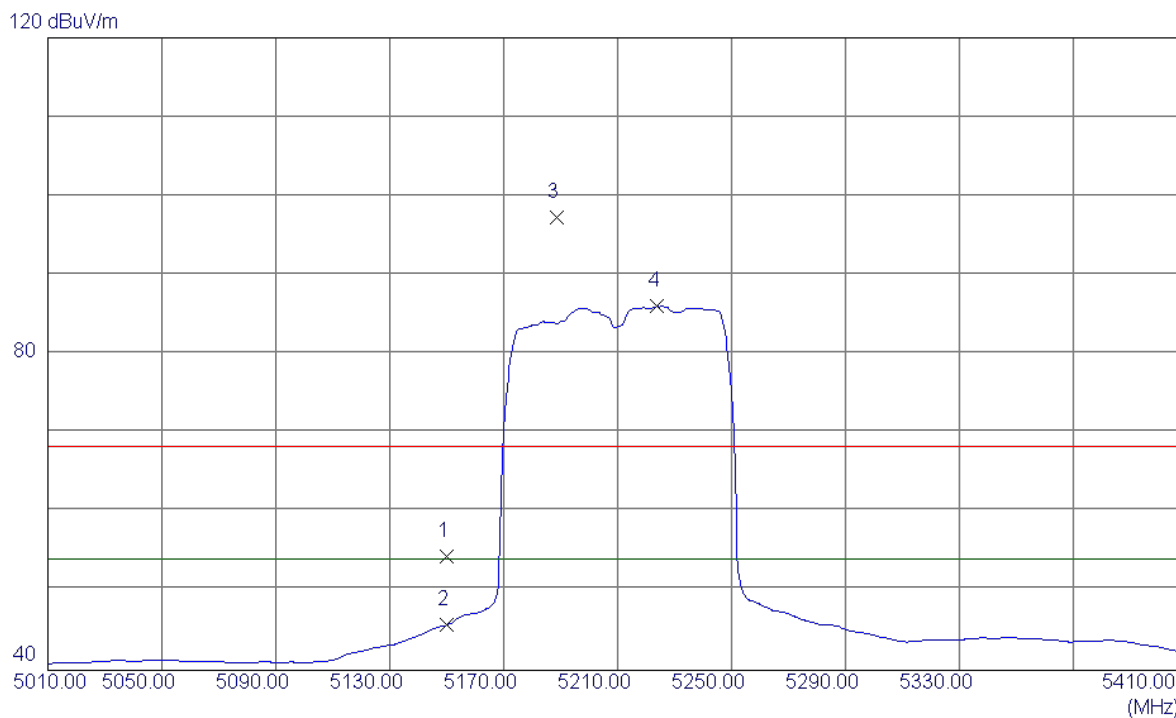

No.	Freq. MHz	Reading Level dBuV/m	Correct Factor dB	Measure ment dBuV/m	Limit dBuV/m	Margin dB	Detector	Comment
1	5150.0000	14.19	40.22	54.41	68.30	-13.89	Peak	
2	5150.0000	5.52	40.22	45.74	54.00	-8.26	AVG	
3	5188.8000	56.96	40.30	97.26	68.30	28.96	Peak	No Limit
4 *	5224.0000	45.68	40.37	86.05	54.00	32.05	AVG	No Limit

Orthogonal Axis:	X
Test Mode:	UNII-1/ TX AC(VHT80) Mode 5210MHz

Horizontal

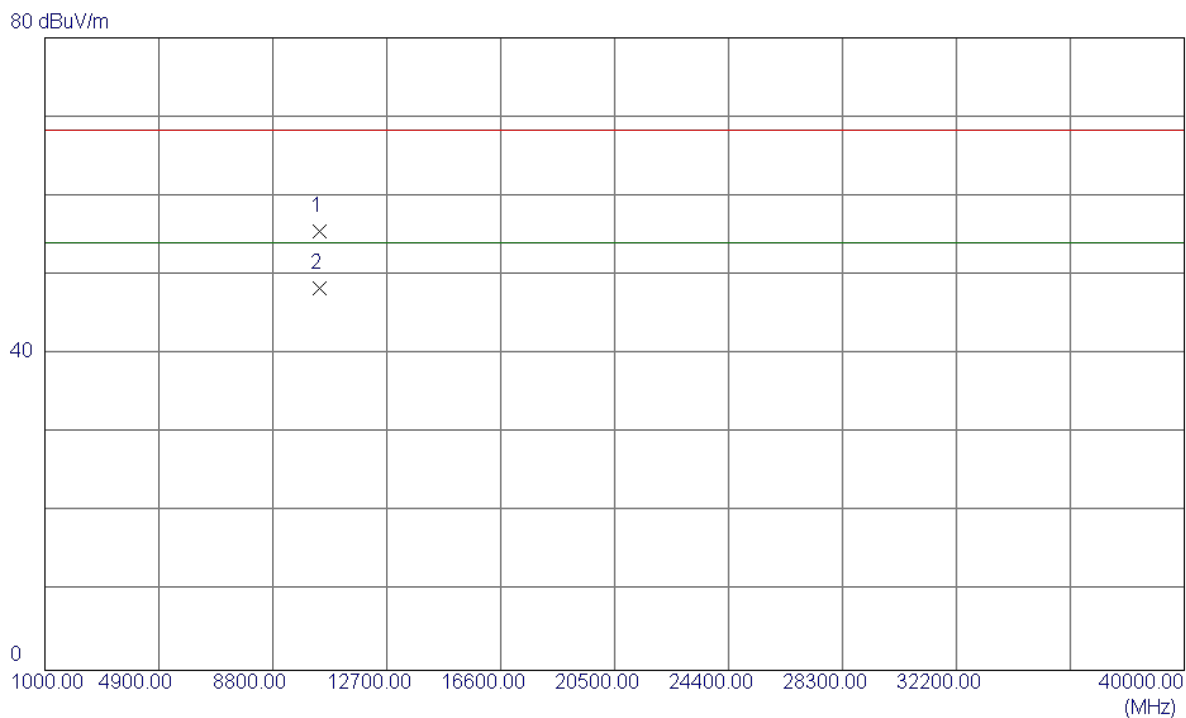

No.	Freq. MHz	Reading Level dBuV/m	Correct Factor dB	Measure ment dBuV/m	Limit dBuV/m	Margin dB	Detector	Comment
1	10419.9700	41.68	13.77	55.45	68.30	-12.85	Peak	
2 *	10419.9700	34.62	13.77	48.39	54.00	-5.61	AVG	

Orthogonal Axis:	X
Test Mode:	UNII-3/TX AC (VHT20MHz) Mode 5745MHz

Vertical

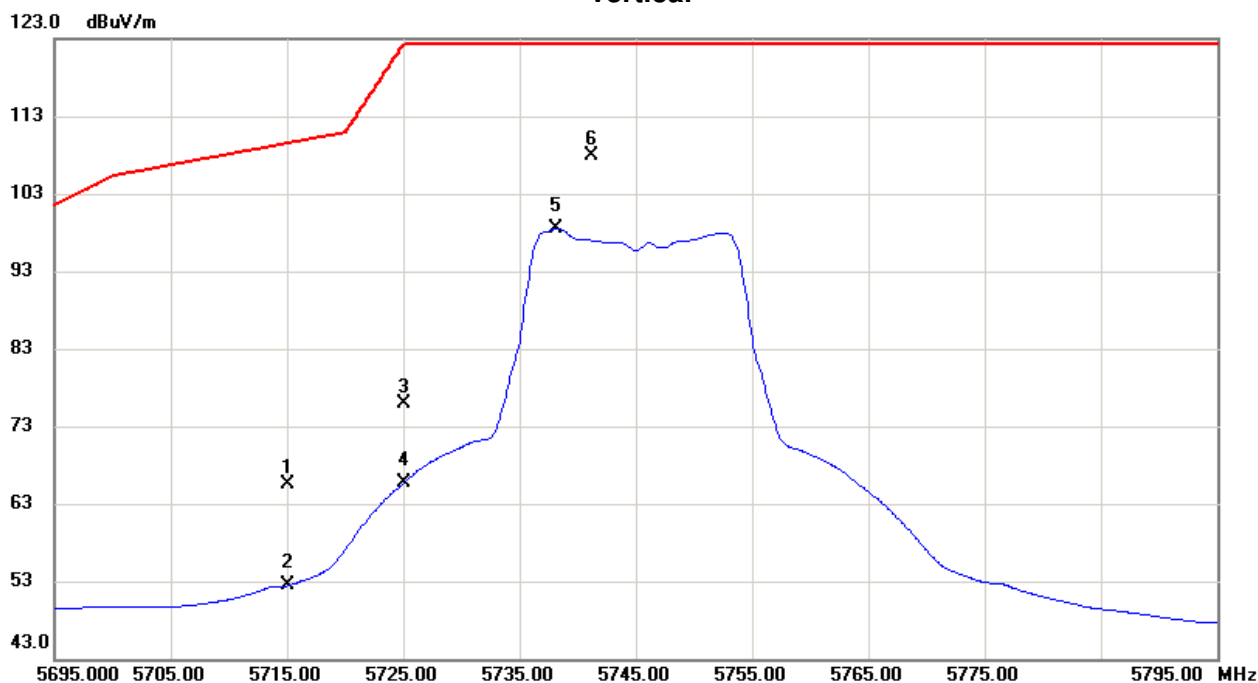

No.	Freq. MHz	Reading Level dBuV/m	Correct Factor dB	Measure ment dBuV/m	Limit dBuV/m	Margin dB	Detector	Comment
1	5715.0000	24.15	41.25	65.40	109.50	-44.10	Peak	
2	5715.0000	11.16	41.25	52.41	109.50	-57.09	AVG	
3	5725.0000	34.58	41.27	75.85	122.30	-46.45	Peak	
4	5725.0000	24.37	41.27	65.64	122.30	-56.66	AVG	
5	5738.2000	57.21	41.28	98.49	122.30	-23.81	AVG	No Limit
6 *	5741.2000	66.53	41.29	107.82	122.30	-14.48	Peak	No Limit

Orthogonal Axis:	X
Test Mode:	UNII-3/TX AC (VHT20MHz) Mode 5745MHz

Vertical

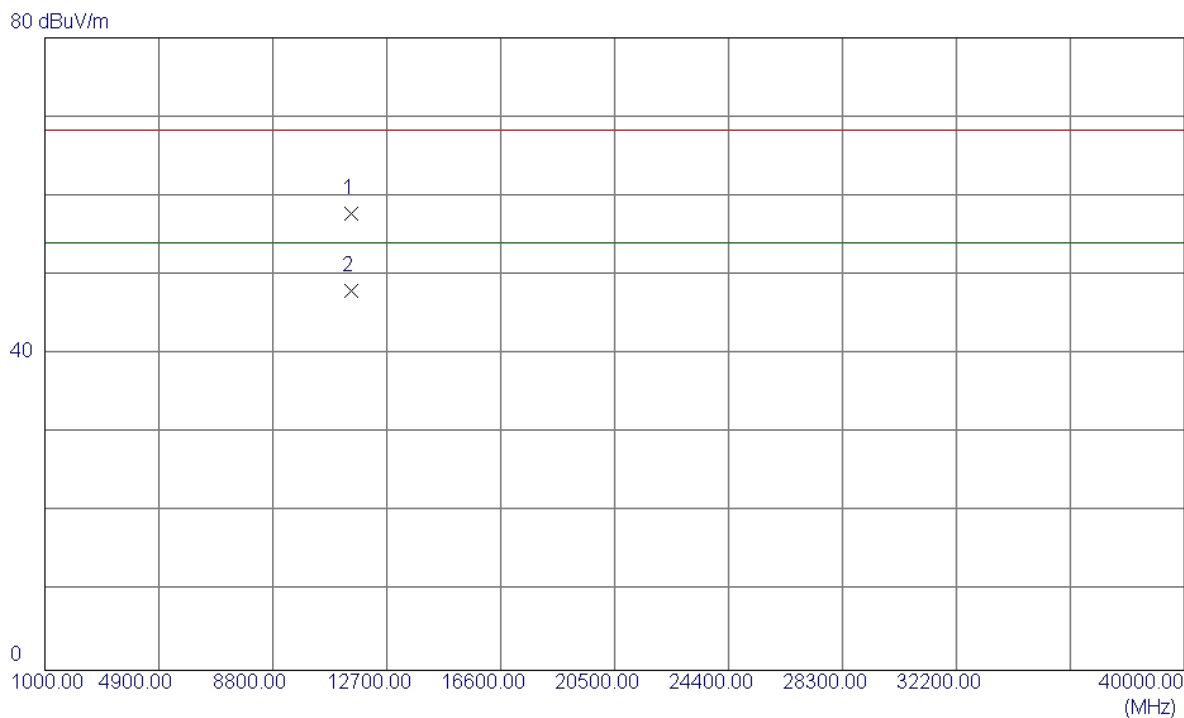

No.	Freq. MHz	Reading Level dBuV/m	Correct Factor dB	Measure ment dBuV/m	Limit dBuV/m	Margin dB	Detector	Comment
1	11490.0000	40.82	16.91	57.73	68.30	-10.57	Peak	
2 *	11490.0000	31.09	16.91	48.00	54.00	-6.00	AVG	

Orthogonal Axis:	X
Test Mode:	UNII-3/TX AC (VHT20MHz) Mode 5745MHz

Horizontal

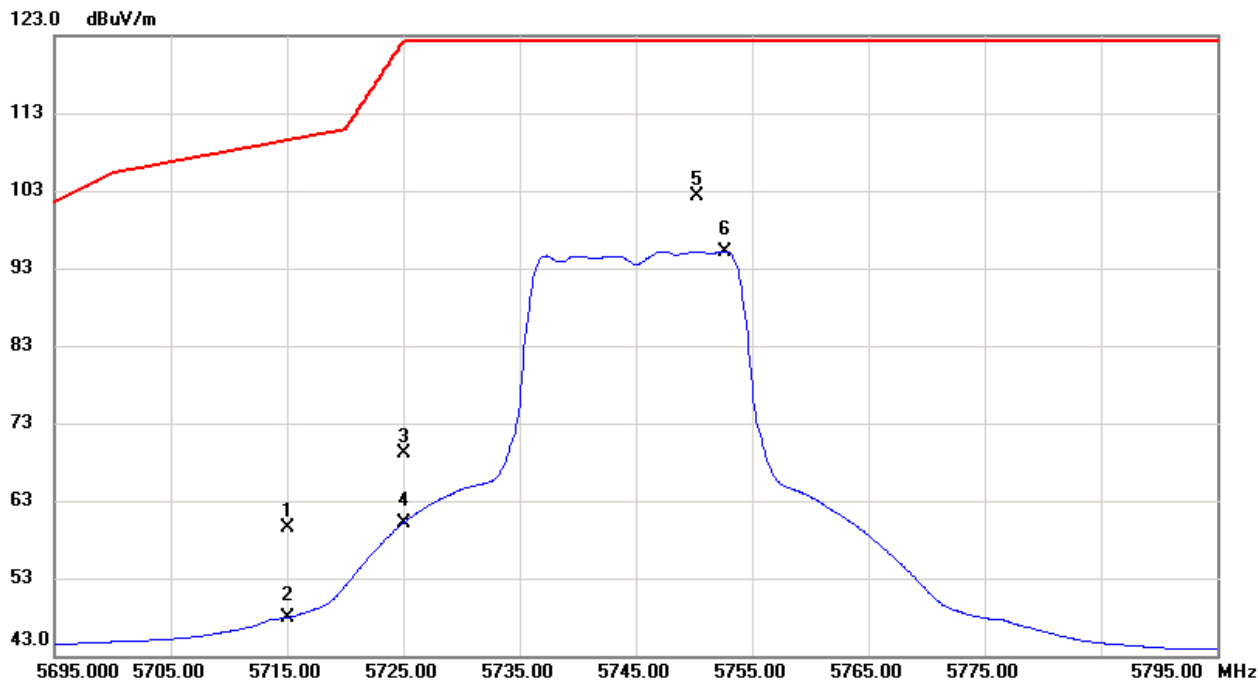

No.	Freq. MHz	Reading Level dBuV/m	Correct Factor dB	Measure ment dBuV/m	Limit dBuV/m	Margin dB	Detector	Comment
1	5715.0000	18.22	41.25	59.47	109.50	-50.03	Peak	
2	5715.0000	6.64	41.25	47.89	109.50	-61.61	AVG	
3	5725.0000	27.77	41.27	69.04	122.30	-53.26	Peak	
4	5725.0000	18.87	41.27	60.14	122.30	-62.16	AVG	
5 *	5750.3000	61.04	41.30	102.34	122.30	-19.96	Peak	No Limit
6	5752.7000	53.90	41.30	95.20	122.30	-27.10	AVG	No Limit

Orthogonal Axis:	X
Test Mode:	UNII-3/TX AC (VHT20MHz) Mode 5745MHz

Horizontal

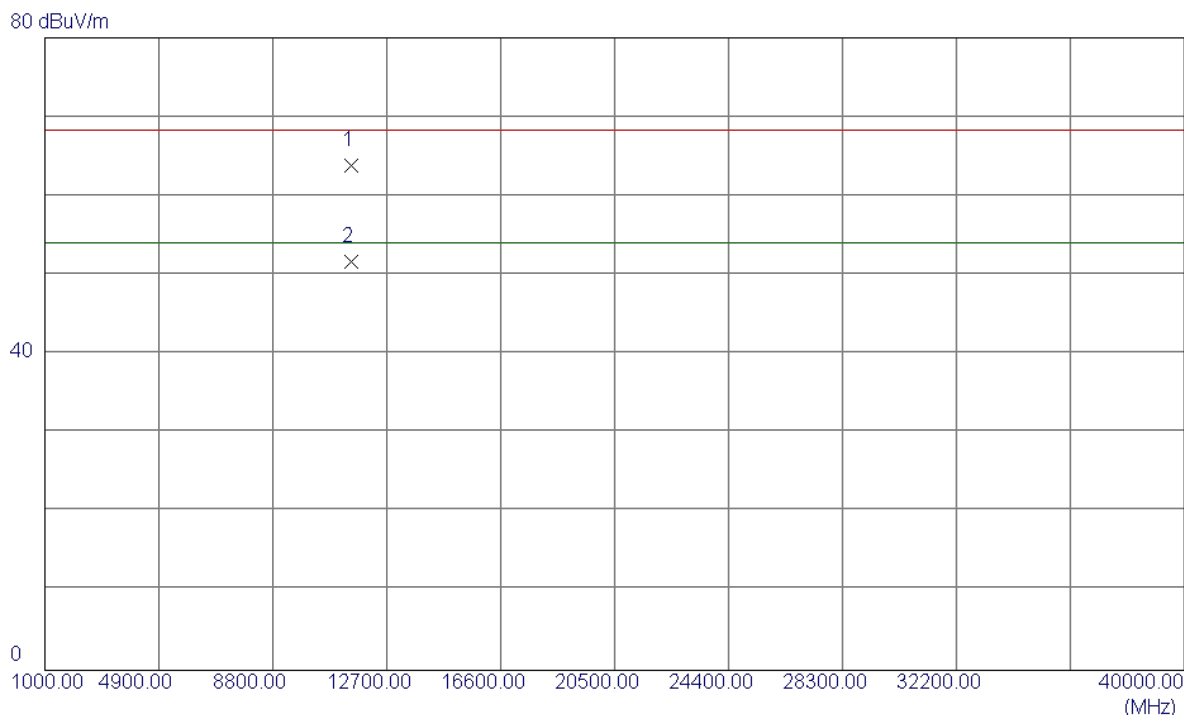

No.	Freq. MHz	Reading Level dBuV/m	Correct Factor dB	Measure ment dBuV/m	Limit dBuV/m	Margin dB	Detector	Comment
1	11489.2000	46.88	16.91	63.79	68.30	-4.51	Peak	
2 *	11490.6000	34.70	16.91	51.61	54.00	-2.39	AVG	

Orthogonal Axis:	X
Test Mode:	UNII-3/TX AC (VHT20MHz) Mode 5785MHz

Vertical

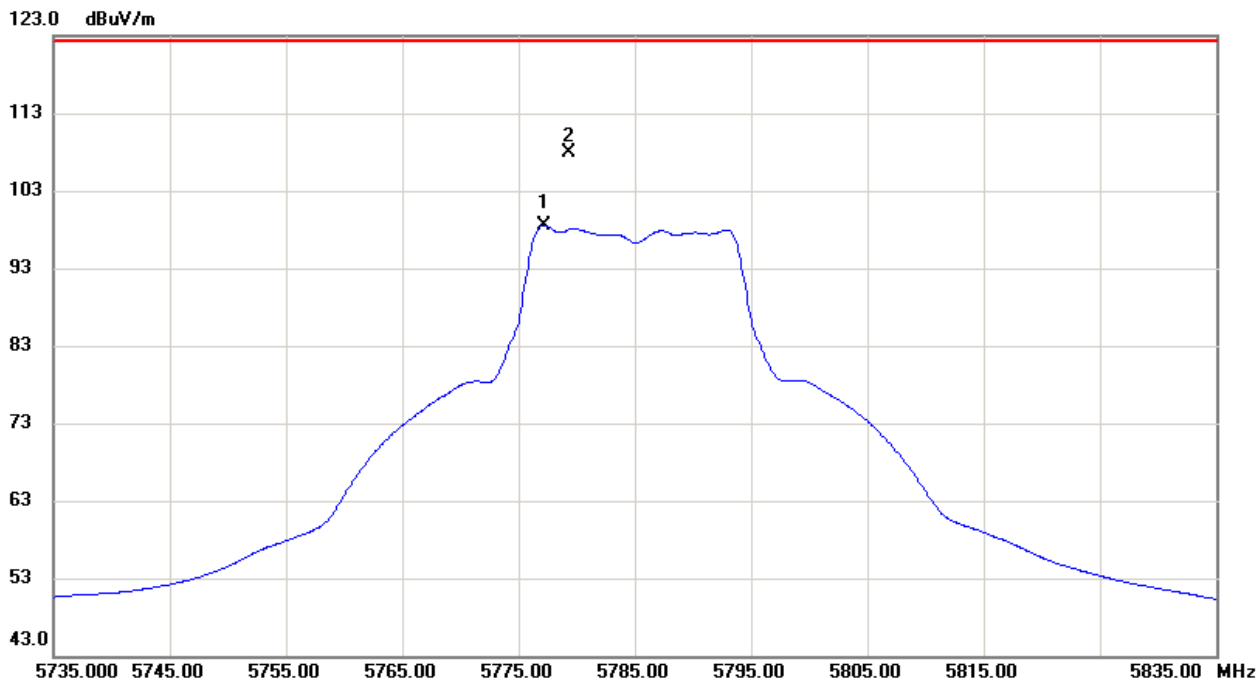

No.	Freq. MHz	Reading Level dBuV/m	Correct Factor dB	Measure ment dBuV/m	Limit dBuV/m	Margin dB	Detector	Comment
1	5777.2000	57.23	41.34	98.57	122.30	-23.73	AVG	No Limit
2 *	5779.3000	66.58	41.34	107.92	122.30	-14.38	Peak	No Limit

Orthogonal Axis:	X
Test Mode:	UNII-3/TX AC (VHT20MHz) Mode 5785MHz

Vertical

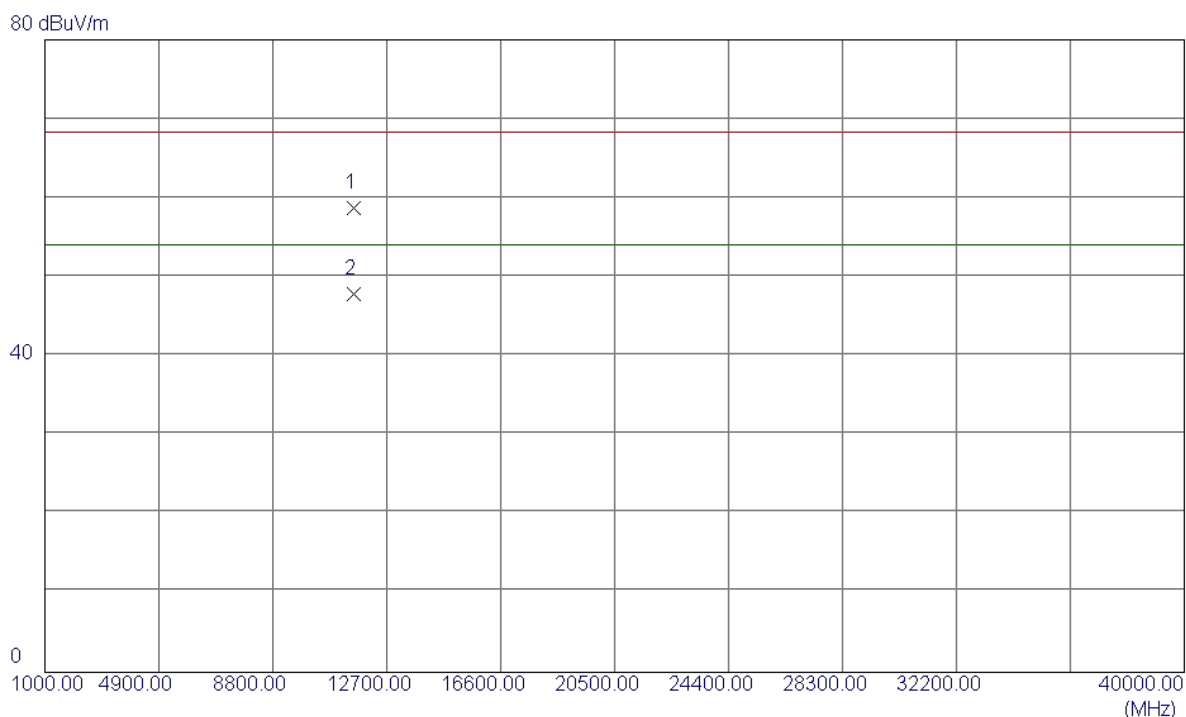

No.	Freq. MHz	Reading Level dBuV/m	Correct Factor dB	Measure ment dBuV/m	Limit dBuV/m	Margin dB	Detector	Comment
1	11569.6000	41.65	17.05	58.70	68.30	-9.60	Peak	
2 *	11570.0000	30.83	17.05	47.88	54.00	-6.12	AVG	

Orthogonal Axis:	X
Test Mode:	UNII-3/TX AC (VHT20MHz) Mode 5785MHz

Horizontal

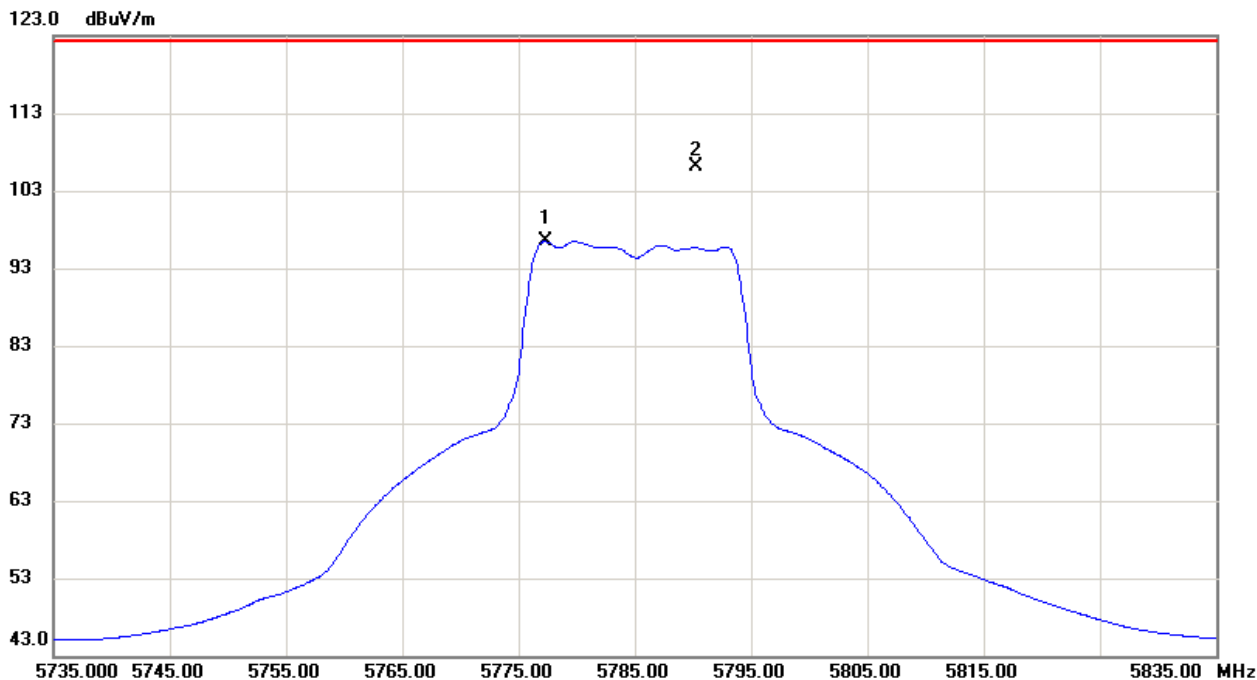

No.	Freq. MHz	Reading Level dBuV/m	Correct Factor dB	Measure ment dBuV/m	Limit dBuV/m	Margin dB	Detector	Comment
1	5777.3000	55.12	41.34	96.46	122.30	-25.84	AVG	No Limit
2 *	5790.3000	64.79	41.35	106.14	122.30	-16.16	Peak	No Limit

Orthogonal Axis:	X
Test Mode:	UNII-3/TX AC (VHT20MHz) Mode 5785MHz

Horizontal

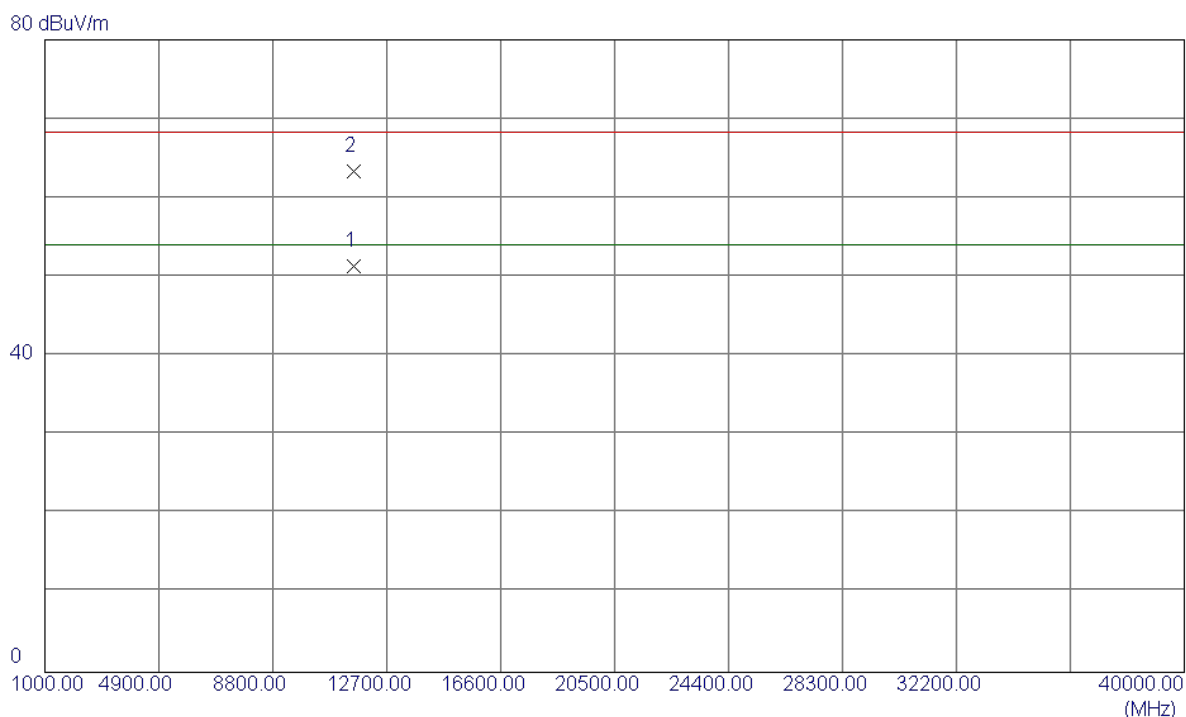

No.	Freq. MHz	Reading Level dBuV/m	Correct Factor dB	Measure ment dBuV/m	Limit dBuV/m	Margin dB	Detector	Comment
1 *	11570.4000	34.38	17.05	51.43	54.00	-2.57	AVG	
2	11574.2000	46.37	17.05	63.42	68.30	-4.88	Peak	

Orthogonal Axis:	X
Test Mode:	UNII-3/TX AC (VHT20MHz) Mode 5825MHz

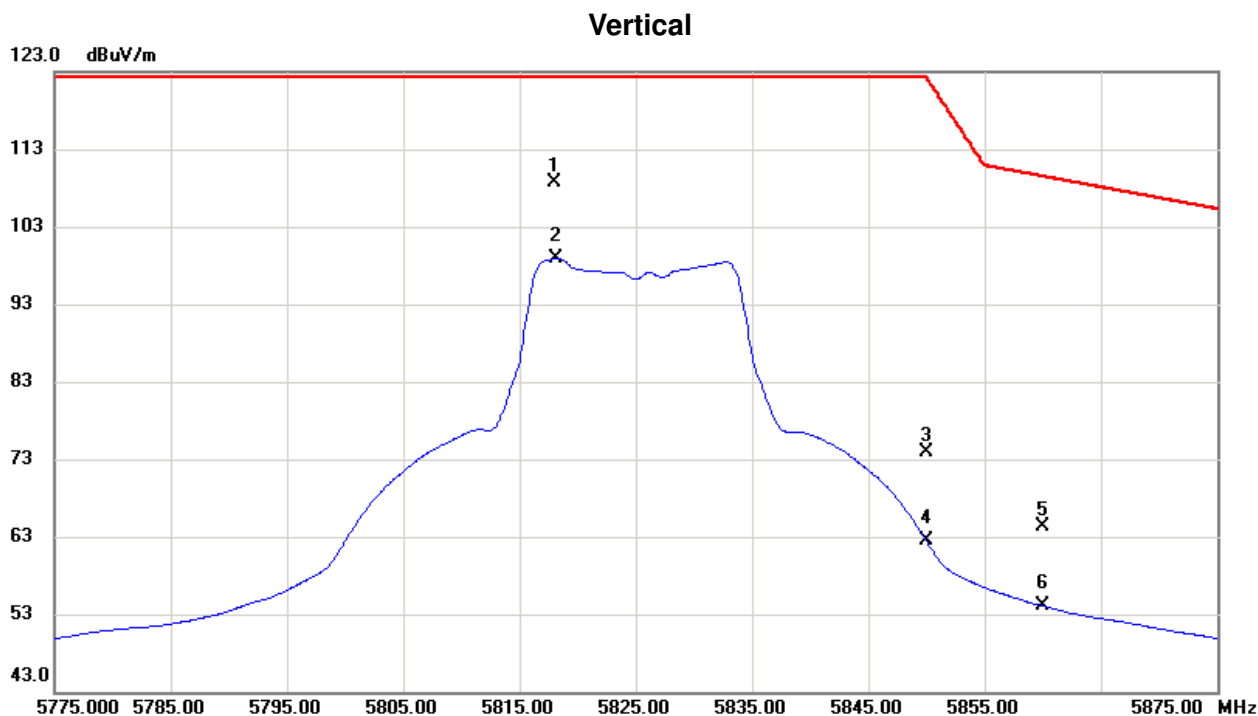

No.	Freq. MHz	Reading Level dBuV/m	Correct Factor dB	Measure ment dBuV/m	Limit dBuV/m	Margin dB	Detector	Comment
1 *	5818.0000	67.25	41.39	108.64	122.30	-13.66	Peak	No Limit
2	5818.1000	57.53	41.39	98.92	122.30	-23.38	AVG	No Limit
3	5850.0000	32.55	41.44	73.99	122.30	-48.31	Peak	
4	5850.0000	21.01	41.44	62.45	122.30	-59.85	AVG	
5	5860.0000	22.75	41.45	64.20	109.50	-45.30	Peak	
6	5860.0000	12.68	41.45	54.13	109.50	-55.37	AVG	

Orthogonal Axis:	X
Test Mode:	UNII-3/TX AC (VHT20MHz) Mode 5825MHz

Vertical

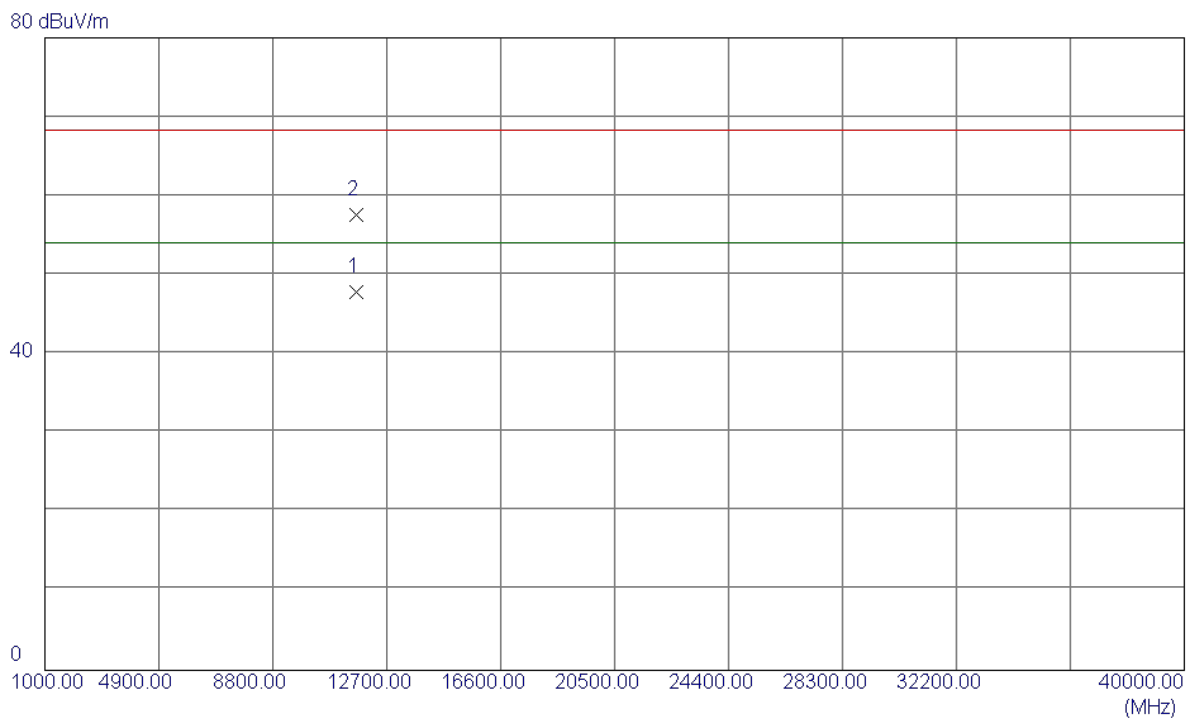

No.	Freq. MHz	Reading Level dBuV/m	Correct Factor dB	Measure ment dBuV/m	Limit dBuV/m	Margin dB	Detector	Comment
1 *	11650.0000	30.68	17.17	47.85	54.00	-6.15	AVG	
2	11650.2000	40.38	17.17	57.55	68.30	-10.75	Peak	

Orthogonal Axis:	X
Test Mode:	UNII-3/TX AC (VHT20MHz) Mode 5825MHz

Horizontal

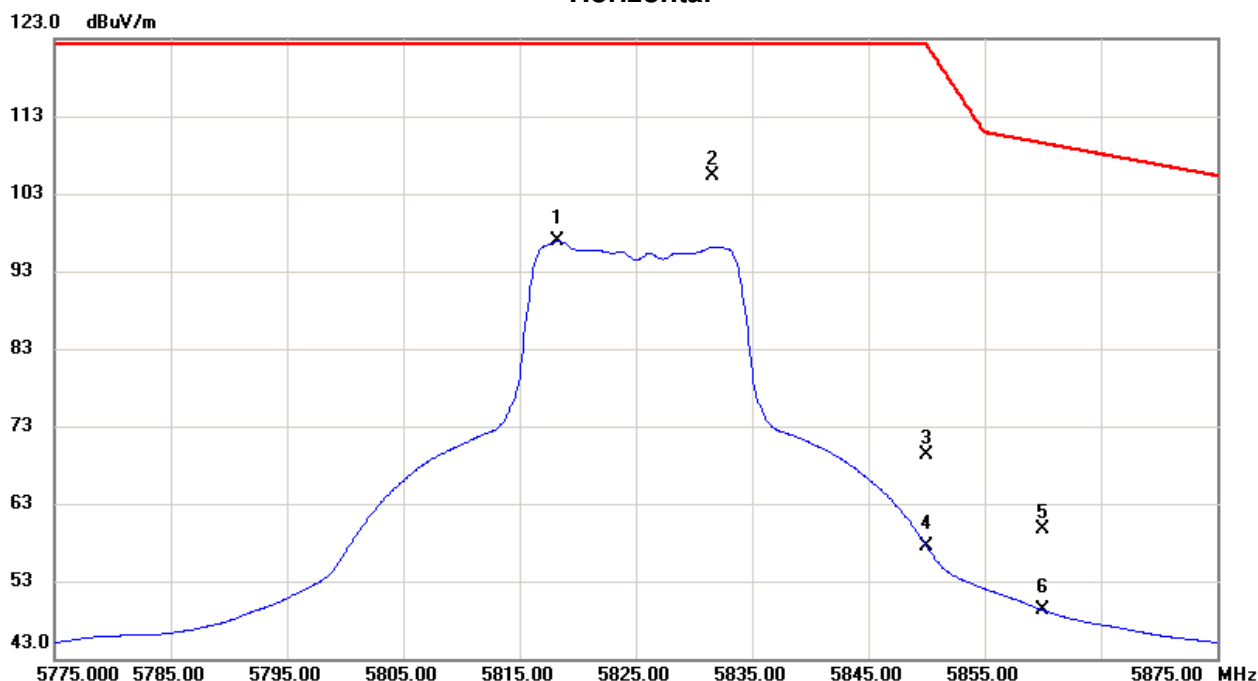

No.	Freq. MHz	Reading Level dBuV/m	Correct Factor dB	Measure ment dBuV/m	Limit dBuV/m	Margin dB	Detector	Comment
1	5818.3000	55.45	41.39	96.84	122.30	-25.46	AVG	No Limit
2 *	5831.6000	63.99	41.41	105.40	122.30	-16.90	Peak	No Limit
3	5850.0000	27.82	41.44	69.26	122.30	-53.04	Peak	
4	5850.0000	16.11	41.44	57.55	122.30	-64.75	AVG	
5	5860.0000	18.28	41.45	59.73	109.50	-49.77	Peak	
6	5860.0000	7.82	41.45	49.27	109.50	-60.23	AVG	

Orthogonal Axis:	X
Test Mode:	UNII-3/TX AC (VHT20MHz) Mode 5825MHz

Horizontal

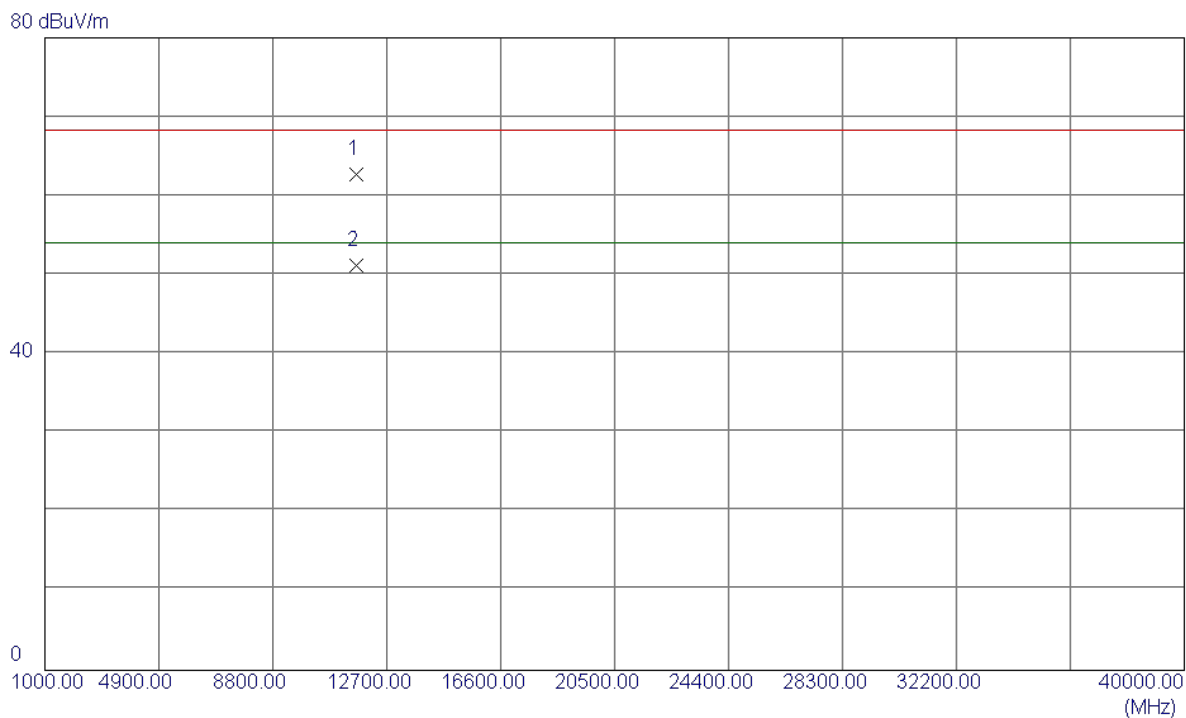

No.	Freq. MHz	Reading Level dBuV/m	Correct Factor dB	Measure ment dBuV/m	Limit dBuV/m	Margin dB	Detector	Comment
1	11649.1000	45.56	17.17	62.73	68.30	-5.57	Peak	
2 *	11650.4000	34.00	17.17	51.17	54.00	-2.83	AVG	

Orthogonal Axis:	X
Test Mode:	UNII-3/TX AC (VHT40MHz) Mode 5755MHz

Vertical

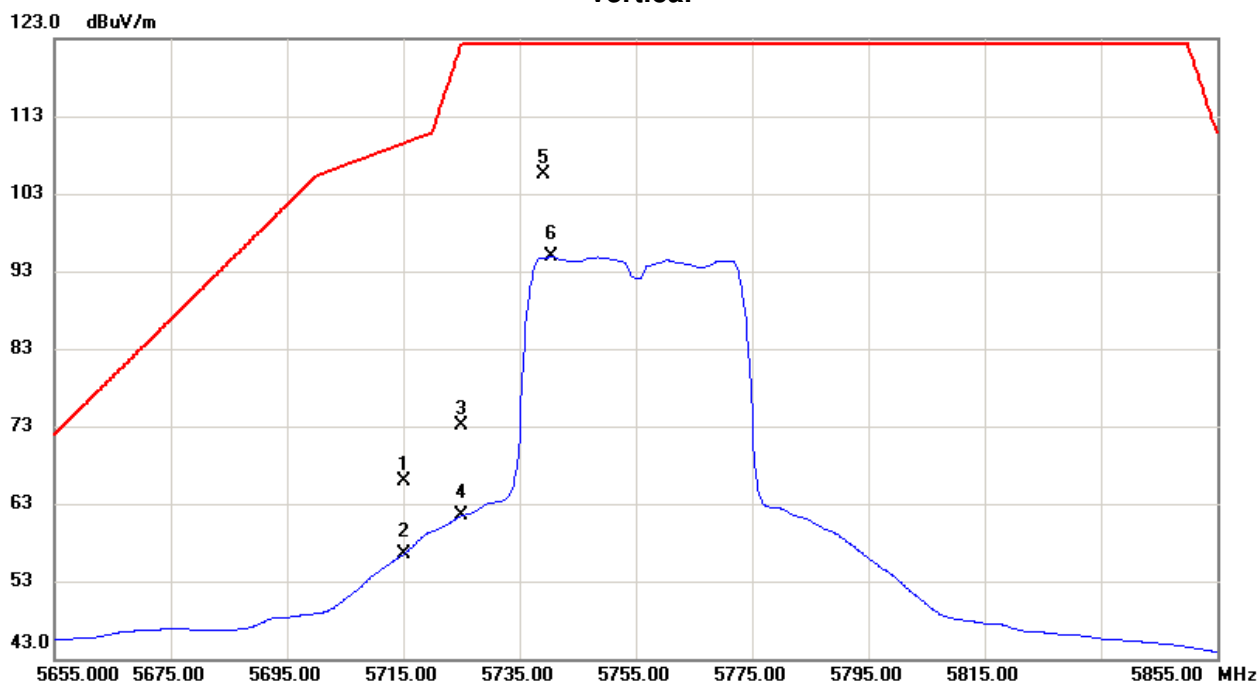

No.	Freq. MHz	Reading Level dBuV/m	Correct Factor dB	Measure ment dBuV/m	Limit dBuV/m	Margin dB	Detector	Comment
1	5715.0000	24.72	41.25	65.97	109.50	-43.53	Peak	
2	5715.0000	15.25	41.25	56.50	109.50	-53.00	AVG	
3	5725.0000	31.85	41.27	73.12	122.30	-49.18	Peak	
4	5725.0000	20.14	41.27	61.41	122.30	-60.89	AVG	
5 *	5739.0000	64.26	41.28	105.54	122.30	-16.76	Peak	No Limit
6	5740.4000	53.63	41.29	94.92	122.30	-27.38	AVG	No Limit

Orthogonal Axis:	X
Test Mode:	UNII-3/TX AC (VHT40MHz) Mode 5755MHz

Vertical

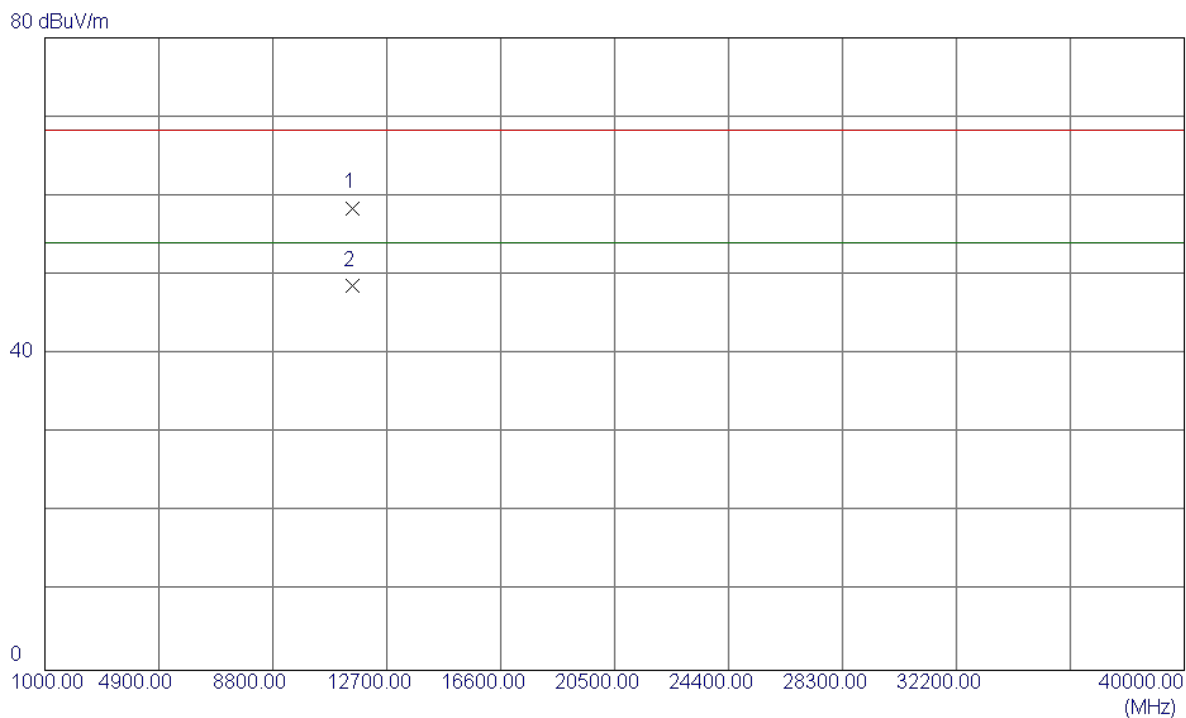

No.	Freq. MHz	Reading Level dBuV/m	Correct Factor dB	Measure ment dBuV/m	Limit dBuV/m	Margin dB	Detector	Comment
1	11509.8800	41.53	16.95	58.48	68.30	-9.82	Peak	
2 *	11509.9700	31.63	16.95	48.58	54.00	-5.42	AVG	

Orthogonal Axis:	X
Test Mode:	UNII-3/TX AC (VHT40MHz) Mode 5755MHz

Horizontal

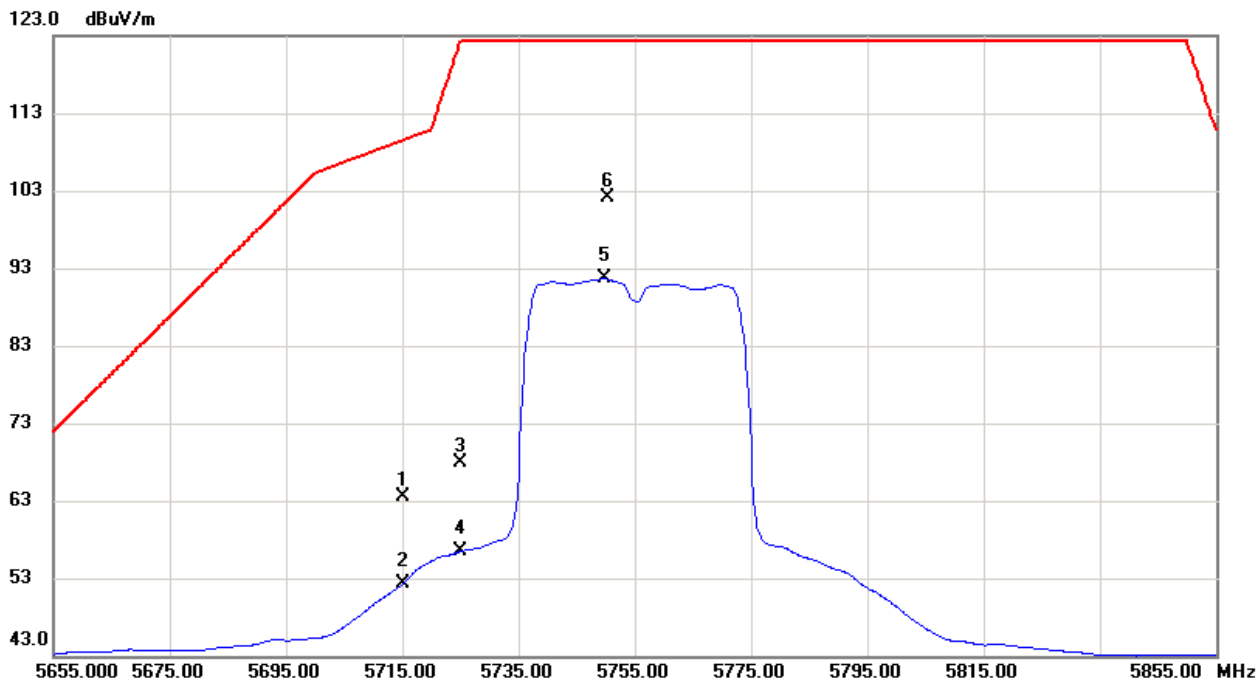

No.	Freq. MHz	Reading Level dBuV/m	Correct Factor dB	Measure ment dBuV/m	Limit dBuV/m	Margin dB	Detector	Comment
1	5715.0000	22.24	41.25	63.49	109.50	-46.01	Peak	
2	5715.0000	10.98	41.25	52.23	109.50	-57.27	AVG	
3	5725.0000	26.69	41.27	67.96	122.30	-54.34	Peak	
4	5725.0000	15.21	41.27	56.48	122.30	-65.82	AVG	
5	5749.8000	50.37	41.30	91.67	122.30	-30.63	AVG	No Limit
6 *	5750.4000	60.90	41.30	102.20	122.30	-20.10	Peak	No Limit

Orthogonal Axis:	X
Test Mode:	UNII-3/TX AC (VHT40MHz) Mode 5755MHz

Horizontal

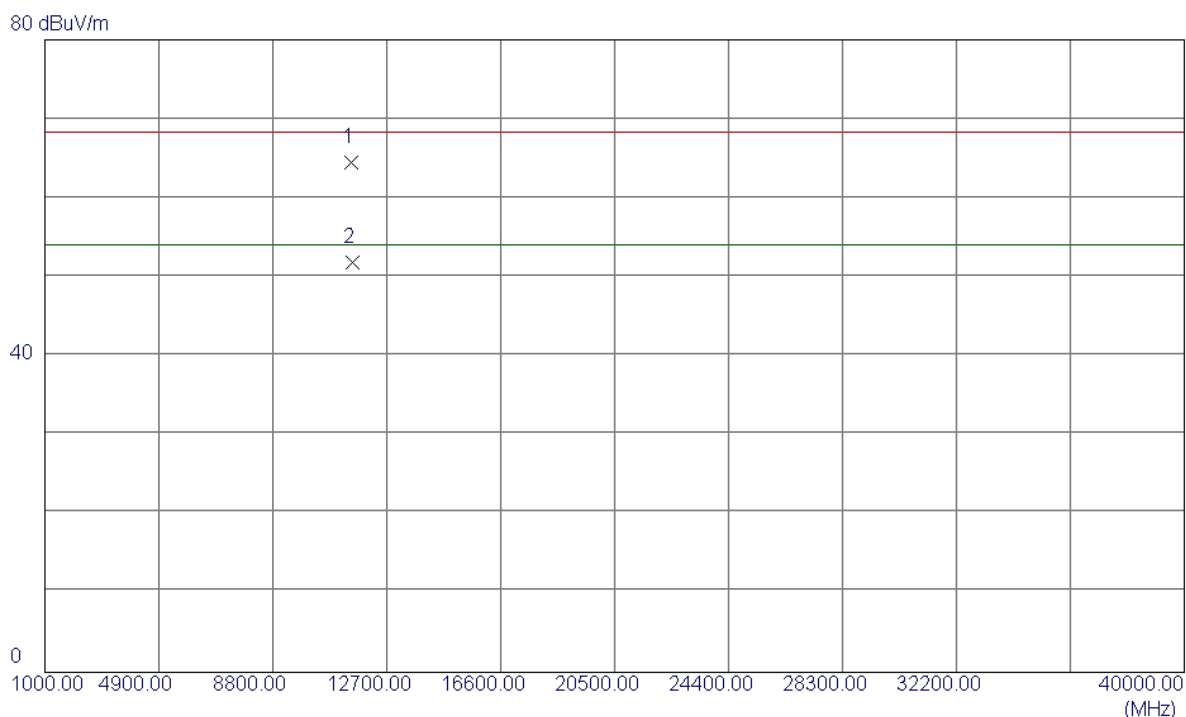

No.	Freq. MHz	Reading Level dBuV/m	Correct Factor dB	Measure ment dBuV/m	Limit dBuV/m	Margin dB	Detector	Comment
1	11506.3000	47.46	16.94	64.40	68.30	-3.90	Peak	
2 *	11511.1000	34.83	16.95	51.78	54.00	-2.22	AVG	

Orthogonal Axis:	X
Test Mode:	UNII-3/TX AC (VHT40MHz) Mode 5795MHz

Vertical

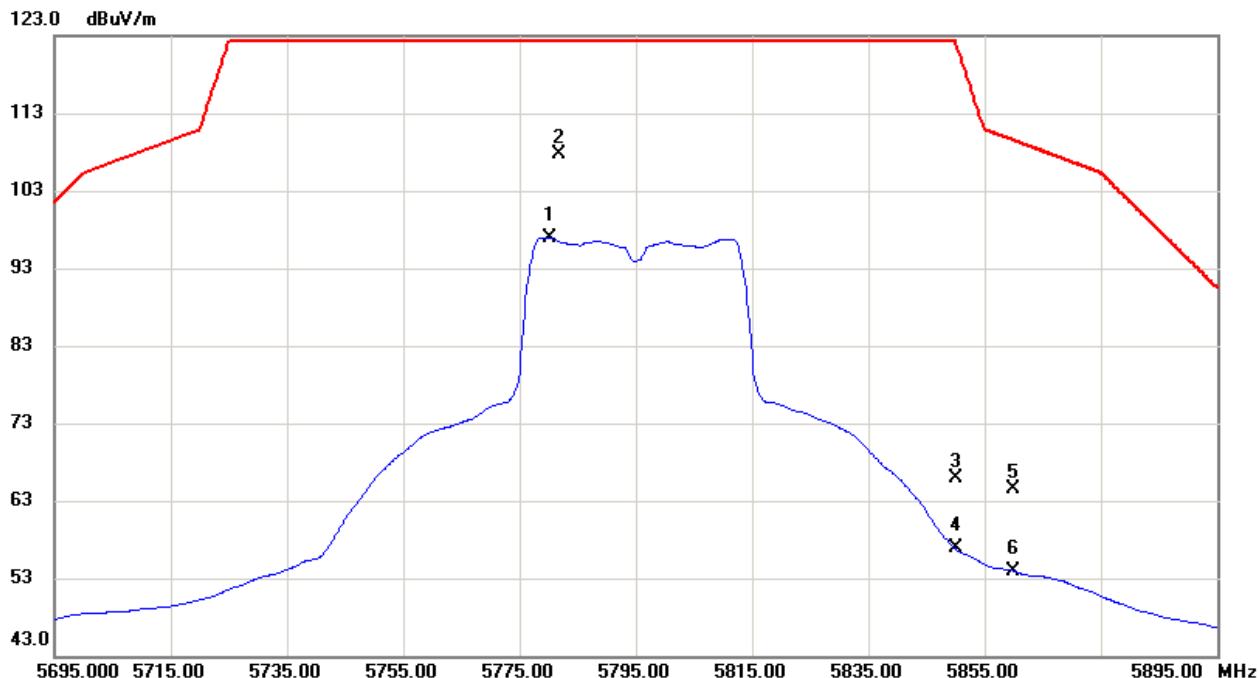

No.	Freq. MHz	Reading Level dBuV/m	Correct Factor dB	Measure ment dBuV/m	Limit dBuV/m	Margin dB	Detector	Comment
1	5780.2000	55.65	41.34	96.99	122.30	-25.31	AVG	No Limit
2 *	5781.8000	66.29	41.34	107.63	122.30	-14.67	Peak	No Limit
3	5850.0000	24.56	41.44	66.00	122.30	-56.30	Peak	
4	5850.0000	15.39	41.44	56.83	122.30	-65.47	AVG	
5	5860.0000	22.97	41.45	64.42	109.50	-45.08	Peak	
6	5860.0000	12.49	41.45	53.94	109.50	-55.56	AVG	

Orthogonal Axis:	X
Test Mode:	UNII-3/TX AC (VHT40MHz) Mode 5795MHz

Vertical

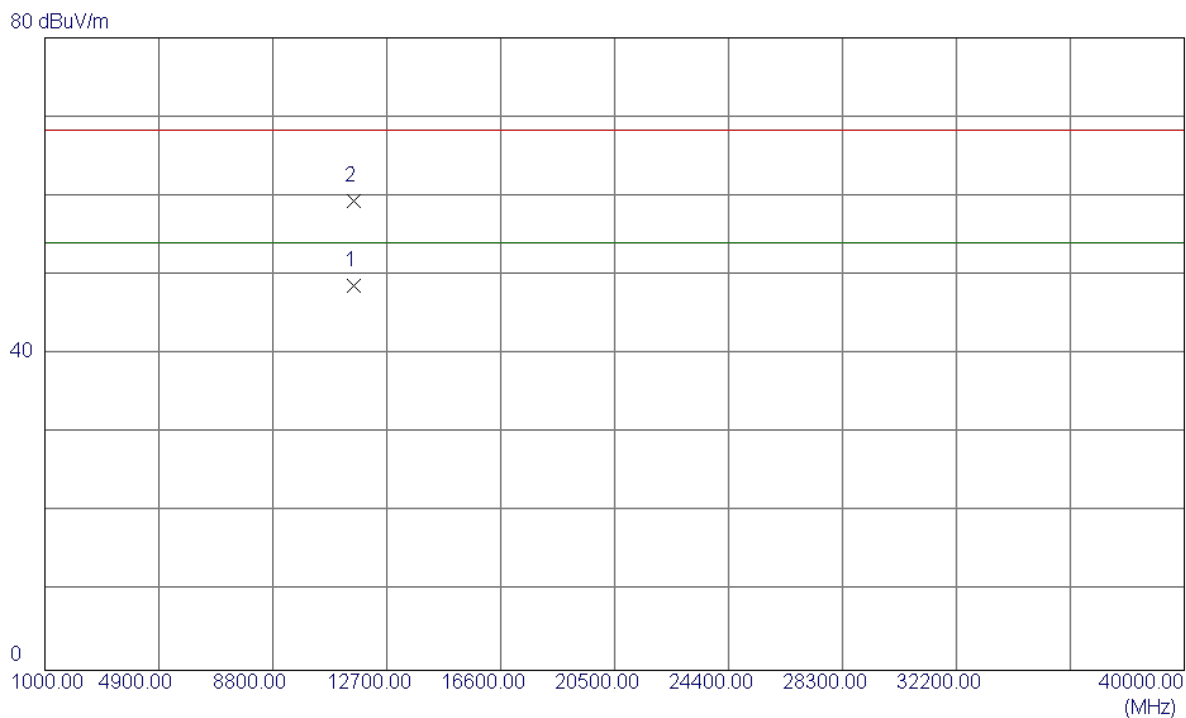

No.	Freq. MHz	Reading Level dBuV/m	Correct Factor dB	Measure ment dBuV/m	Limit dBuV/m	Margin dB	Detector	Comment
1 *	11589.9600	31.52	17.08	48.60	54.00	-5.40	AVG	
2	11590.0000	42.24	17.08	59.32	68.30	-8.98	Peak	

Orthogonal Axis:	X
Test Mode:	UNII-3/TX AC (VHT40MHz) Mode 5795MHz

Horizontal

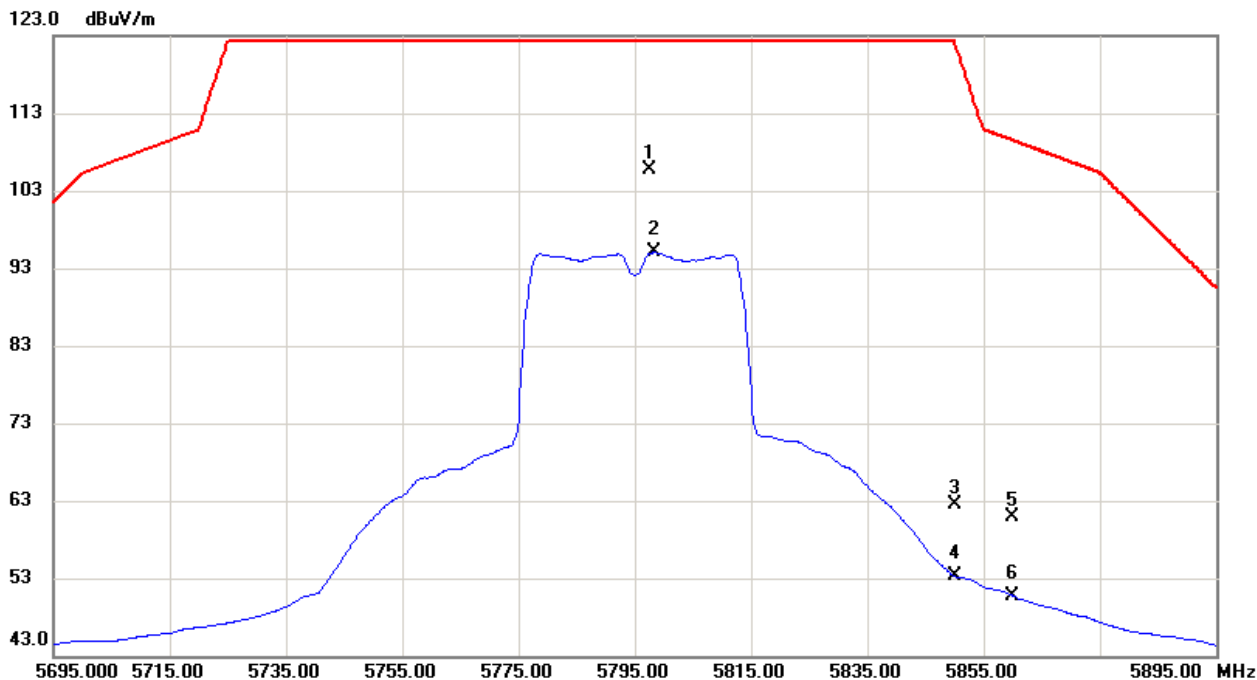

No.	Freq. MHz	Reading Level dBuV/m	Correct Factor dB	Measure ment dBuV/m	Limit dBuV/m	Margin dB	Detector	Comment
1 *	5797.6000	64.35	41.36	105.71	122.30	-16.59	Peak	No Limit
2	5798.4000	53.64	41.37	95.01	122.30	-27.29	AVG	No Limit
3	5850.0000	21.12	41.44	62.56	122.30	-59.74	Peak	
4	5850.0000	11.85	41.44	53.29	122.30	-69.01	AVG	
5	5860.0000	19.40	41.45	60.85	109.50	-48.65	Peak	
6	5860.0000	9.33	41.45	50.78	109.50	-58.72	AVG	

Orthogonal Axis:	X
Test Mode:	UNII-3/TX AC (VHT40MHz) Mode 5795MHz

Horizontal

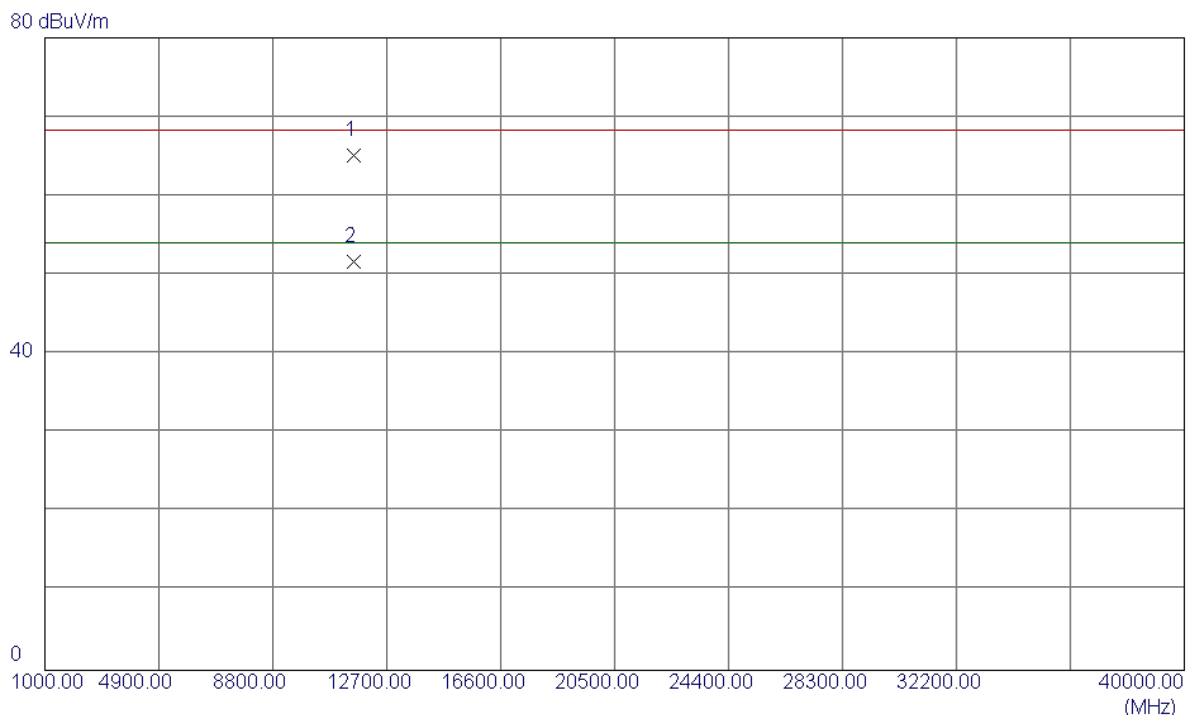

No.	Freq. MHz	Reading Level dBuV/m	Correct Factor dB	Measure ment dBuV/m	Limit dBuV/m	Margin dB	Detector	Comment
1	11586.7000	48.03	17.07	65.10	68.30	-3.20	Peak	
2 *	11591.1000	34.68	17.08	51.76	54.00	-2.24	AVG	

Orthogonal Axis:	X
Test Mode:	UNII-3/TX AC(VHT80) Mode 5775MHz

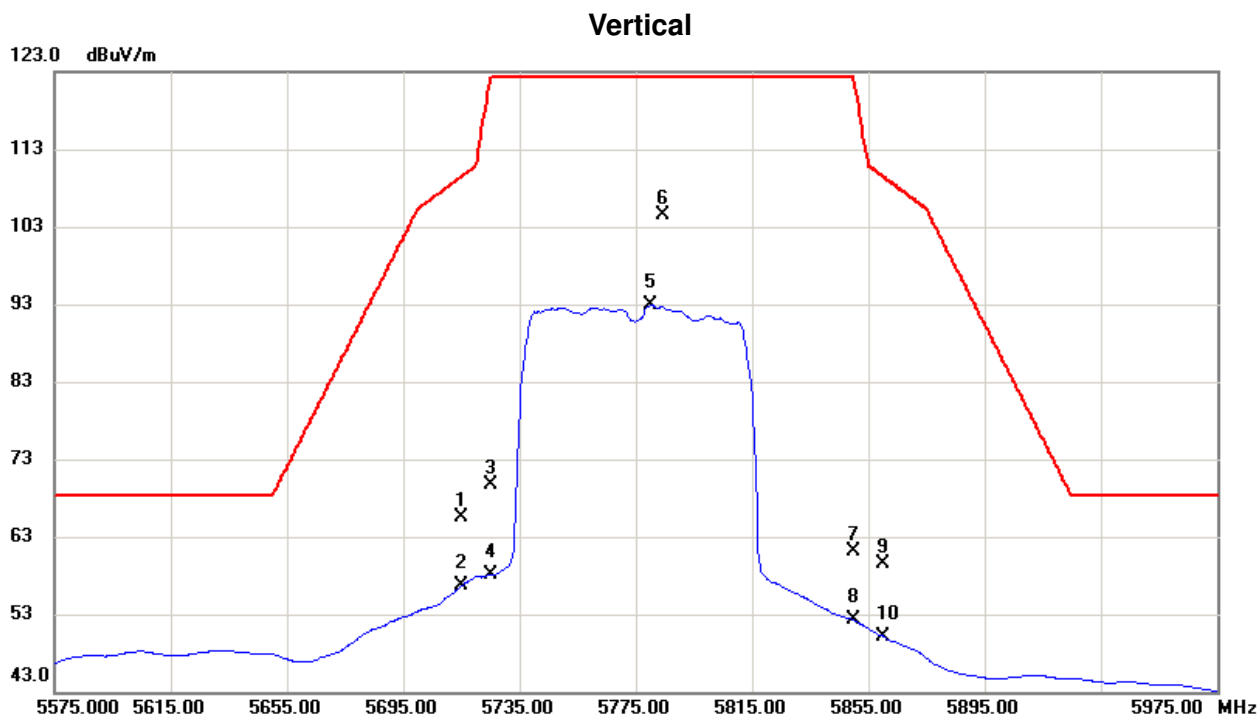

No.	Freq. MHz	Reading Level dBuV/m	Correct Factor dB	Measure ment dBuV/m	Limit dBuV/m	Margin dB	Detector	Comment
1	5715.0000	24.15	41.25	65.40	109.50	-44.10	Peak	
2	5715.0000	15.36	41.25	56.61	109.50	-52.89	AVG	
3	5725.0000	28.38	41.27	69.65	122.30	-52.65	Peak	
4	5725.0000	16.85	41.27	58.12	122.30	-64.18	AVG	
5	5780.2000	51.50	41.34	92.84	122.30	-29.46	AVG	No Limit
6 *	5784.2000	63.10	41.35	104.45	122.30	-17.85	Peak	No Limit
7	5850.0000	19.61	41.44	61.05	122.30	-61.25	Peak	
8	5850.0000	10.77	41.44	52.21	122.30	-70.09	AVG	
9	5860.0000	18.07	41.45	59.52	109.50	-49.98	Peak	
10	5860.0000	8.72	41.45	50.17	109.50	-59.33	AVG	

Orthogonal Axis:	X
Test Mode:	UNII-3/TX AC(VHT80) Mode 5775MHz

Vertical

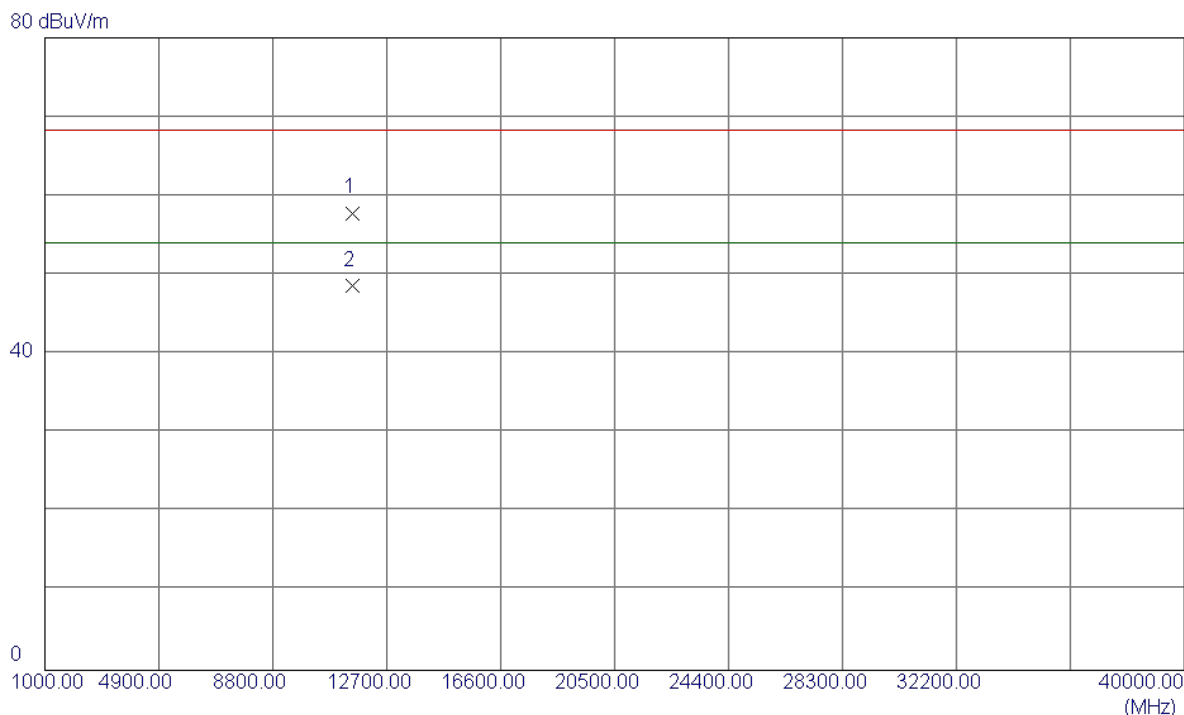

No.	Freq. MHz	Reading Level dBuV/m	Correct Factor dB	Measure ment dBuV/m	Limit dBuV/m	Margin dB	Detector	Comment
1	11549.9600	40.83	17.01	57.84	68.30	-10.46	Peak	
2 *	11549.9800	31.60	17.01	48.61	54.00	-5.39	AVG	

Orthogonal Axis:	X
Test Mode:	UNII-3/TX AC(VHT80) Mode 5775MHz

Horizontal

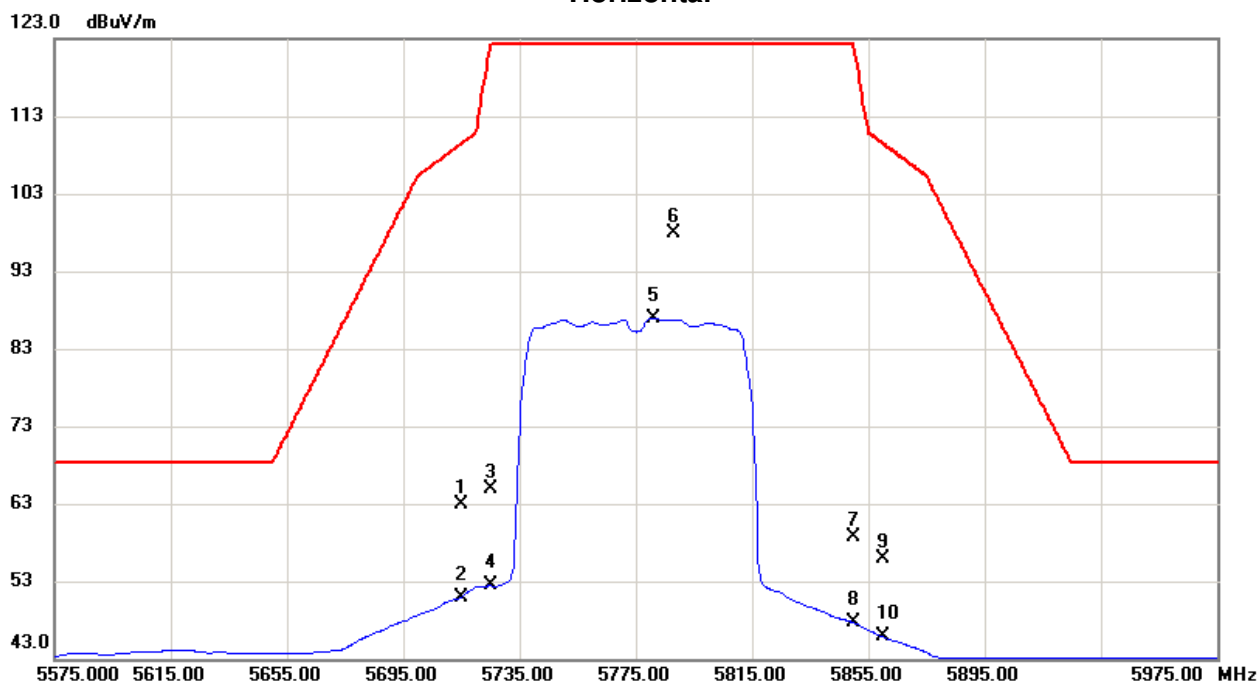

No.	Freq. MHz	Reading Level dBuV/m	Correct Factor dB	Measure ment dBuV/m	Limit dBuV/m	Margin dB	Detector	Comment
1	5715.0000	21.73	41.25	62.98	109.50	-46.52	Peak	
2	5715.0000	9.74	41.25	50.99	109.50	-58.51	AVG	
3	5725.0000	23.66	41.27	64.93	122.30	-57.37	Peak	
4	5725.0000	11.16	41.27	52.43	122.30	-69.87	AVG	
5	5781.4000	45.62	41.34	86.96	122.30	-35.34	AVG	No Limit
6 *	5787.8000	56.65	41.35	98.00	122.30	-24.30	Peak	No Limit
7	5850.0000	17.19	41.44	58.63	122.30	-63.67	Peak	
8	5850.0000	6.19	41.44	47.63	122.30	-74.67	AVG	
9	5860.0000	14.39	41.45	55.84	109.50	-53.66	Peak	
10	5860.0000	4.39	41.45	45.84	109.50	-63.66	AVG	

Orthogonal Axis:	X
Test Mode:	UNII-3/TX AC(VHT80) Mode 5775MHz

Horizontal

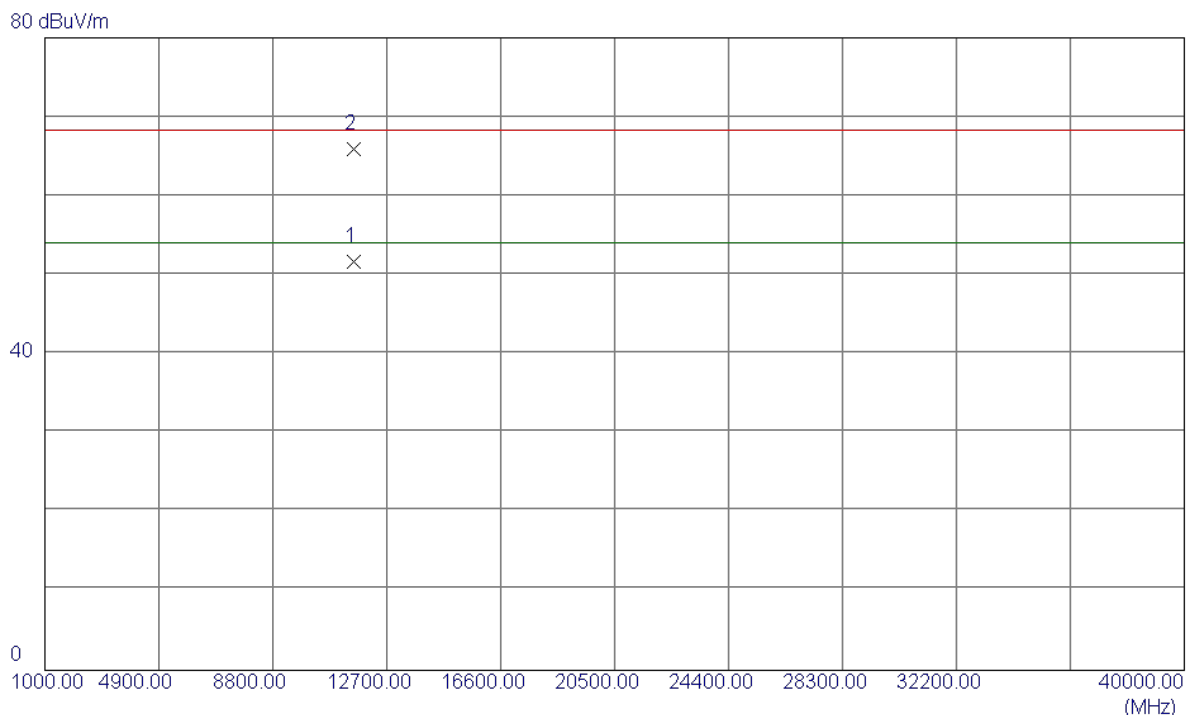

No.	Freq. MHz	Reading Level dBuV/m	Correct Factor dB	Measure ment dBuV/m	Limit dBuV/m	Margin dB	Detector	Comment
1 *	11561.6000	34.64	17.03	51.67	54.00	-2.33	AVG	
2	11566.8000	48.81	17.04	65.85	68.30	-2.45	Peak	

TX A Mode_DUTY CYCLE

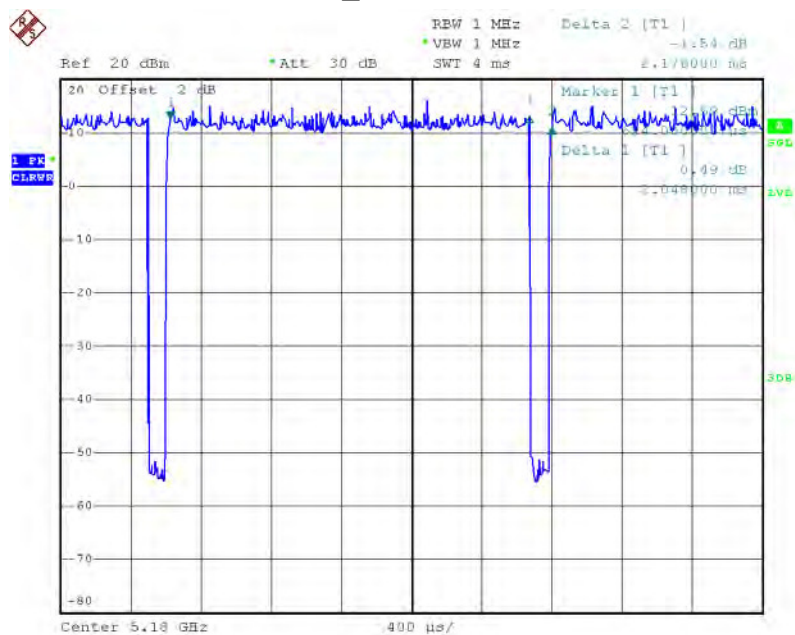

Date: 9.APR.2016 14:20:28

Duty cycle: TX DUTYMHZ

$$\text{Duty cycle} = T_{\text{ON}} / T_{\text{Total}}$$

T_{ON} : 2.05 msec

T_{Total} : 2.18 msec

Duty cycle: 94.04%

$$\text{Duty Factor} = 10 \log(1/\text{Duty cycle})$$

Duty Factor = 0.27

Note: The EUT was programmed to be in continuously transmitting mode and the transmit duty cycle is less than 98 %, so, the output power and power density should be calculated as

Output Power = Measured power + Duty factor

Power Spectral Density = Measured density + Duty factor

TX N20 Mode_DUTY CYCLE

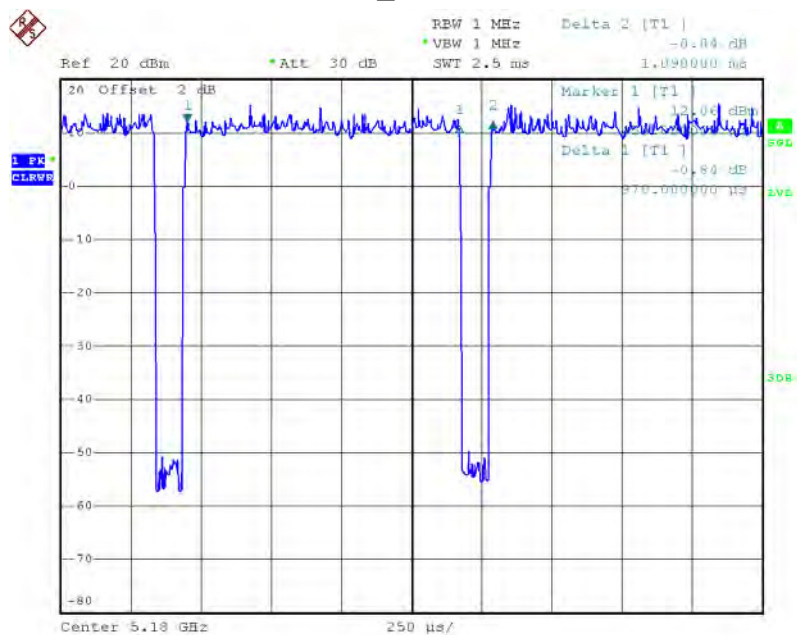

Date: 9.APR.2016 14:18:11

Duty cycle: TX DUTYMHZ

$$\text{Duty cycle} = T_{\text{ON}} / T_{\text{Total}}$$

T_{ON} : 0.97 msec

T_{Total} : 1.09 msec

Duty cycle: 88.99%

$$\text{Duty Factor} = 10 \log(1/\text{Duty cycle})$$

Duty Factor = 0.51

Note: The EUT was programmed to be in continuously transmitting mode and the transmit duty cycle is less than 98 %, so, the output power and power density should be calculated as

Output Power = Measured power + Duty factor

Power Spectral Density = Measured density + Duty factor

TX N40 Mode_DUTY CYCLE

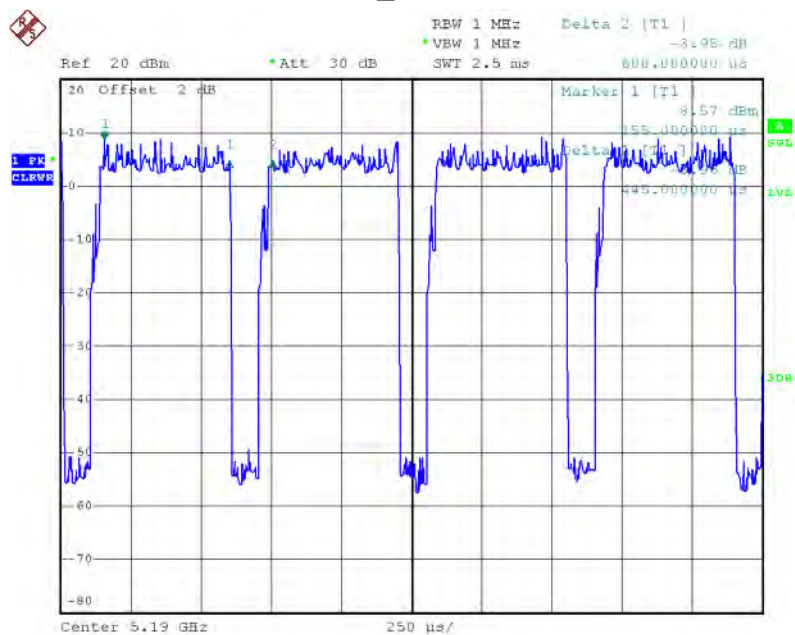

Date: 9.APR.2016 14:19:37

Duty cycle: TX DUTYMHZ

$$\text{Duty cycle} = T_{\text{ON}} / T_{\text{Total}}$$

T_{ON} : 0.44 msec

T_{Total} : 0.60 msec

Duty cycle: 73.33%

$$\text{Duty Factor} = 10 \log(1/\text{Duty cycle})$$

Duty Factor = 1.35

Note: The EUT was programmed to be in continuously transmitting mode and the transmit duty cycle is less than 98 %, so, the output power and power density should be calculated as

Output Power = Measured power + Duty factor

Power Spectral Density = Measured density + Duty factor

TX AC (VHT20MHz) Mode_DUTY CYCLE

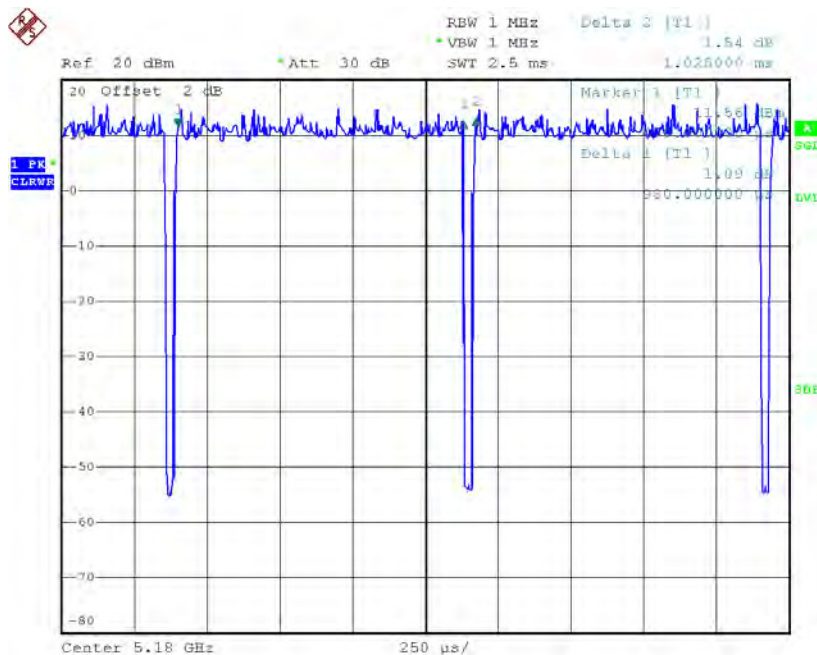

Date: 9.APR.2016 14:21:45

Duty cycle: TX DUTYMHZ

$$\text{Duty cycle} = T_{\text{ON}} / T_{\text{Total}}$$

T_{ON} : 0.98 msec

T_{Total} : 1.03 msec

Duty cycle: 95.15%

$$\text{Duty Factor} = 10 \log(1/\text{Duty cycle})$$

Duty Factor = 0.22

Note: The EUT was programmed to be in countinously transmitting mode and the transmit duty cycle is less than 98 %, so, the output power and power density should be cacluated as

Output Power = Measured power + Ducus factor

Power Spectral Density = Measured density + Duty factor

TX AC (VHT40MHz) Mode_DUTY CYCLE

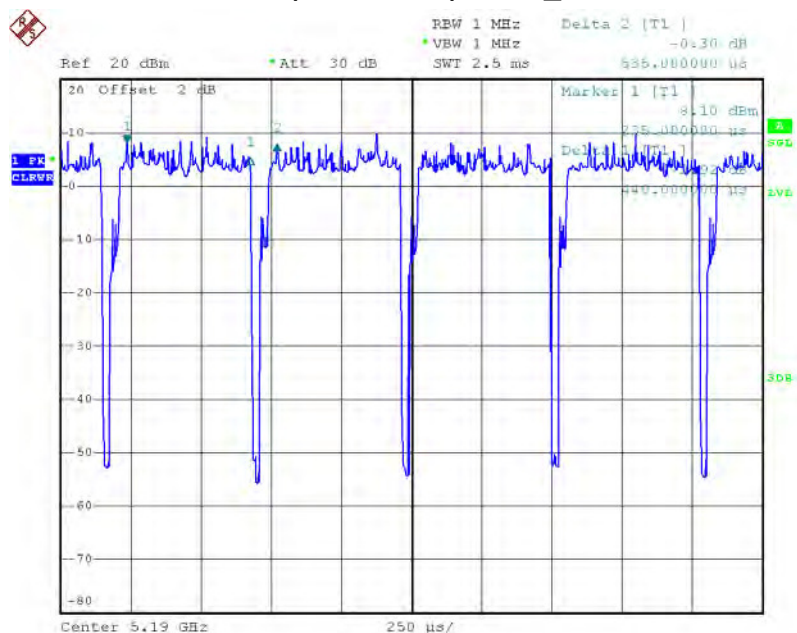

Date: 9.APR.2016 14:23:04

Duty cycle: TX DUTYMHZ

$$\text{Duty cycle} = T_{\text{ON}} / T_{\text{Total}}$$

T_{ON} : 0.44 msec

T_{Total} : 0.54 msec

Duty cycle: 81.48%

$$\text{Duty Factor} = 10 \log(1/\text{Duty cycle})$$

Duty Factor = 0.89

Note: The EUT was programmed to be in continuously transmitting mode and the transmit duty cycle is less than 98 %, so, the output power and power density should be calculated as

Output Power = Measured power + Duty factor

Power Spectral Density = Measured density + Duty factor

TX AC(VHT80) Mode_DUTY CYCLE

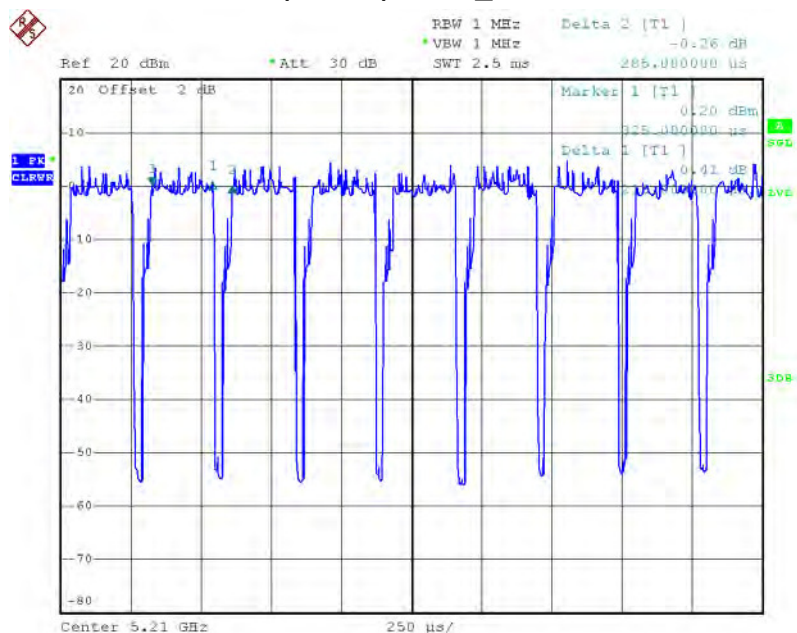

Date: 9.APR.2016 14:45:19

Duty cycle: TX DUTYMHZ

$$\text{Duty cycle} = T_{\text{ON}} / T_{\text{Total}}$$

T_{ON} : 0.22 msec

T_{Total} : 0.28 msec

Duty cycle: 78.57%

$$\text{Duty Factor} = 10 \log(1/\text{Duty cycle})$$

Duty Factor = 1.05

Note: The EUT was programmed to be in countinously transmitting mode and the transmit duty cycle is less than 98 %, so, the output power and power density should be cacluated as

Output Power = Measured power + Ducus factor

Power Spectral Density = Measured density + Duty factor

ATTACHMENT E - BANDWIDTH

Test Mode: UNII-1/TX A Mode_CH36/CH40/CH48

Channel	Frequency (MHz)	26dB Bandwidth (MHz)	99% Occupied Bandwidth (MHz)
CH36	5180	21.80	17.30
CH40	5200	21.79	17.30
CH48	5240	21.80	17.30

TX CH36

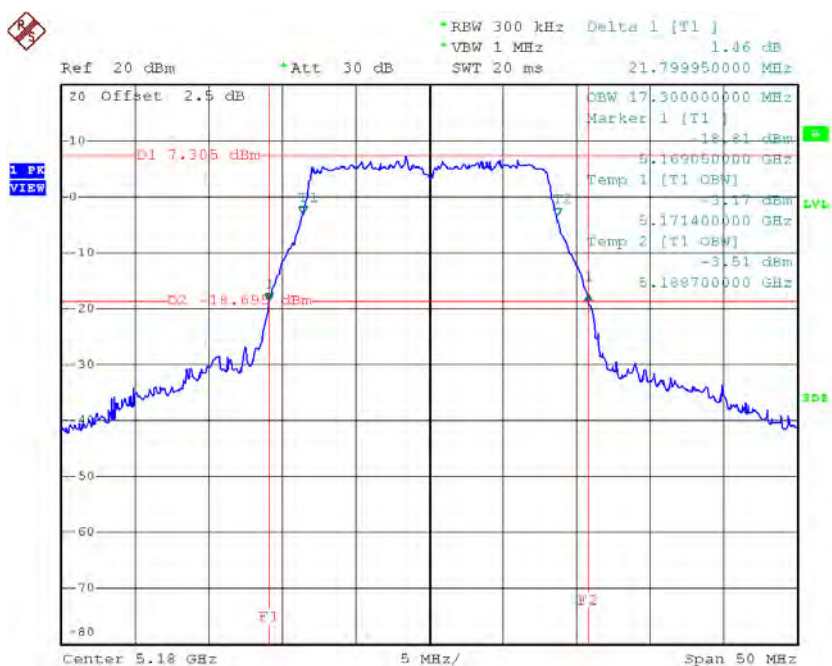

Date: 15.APR.2016 11:32:00

TX CH40

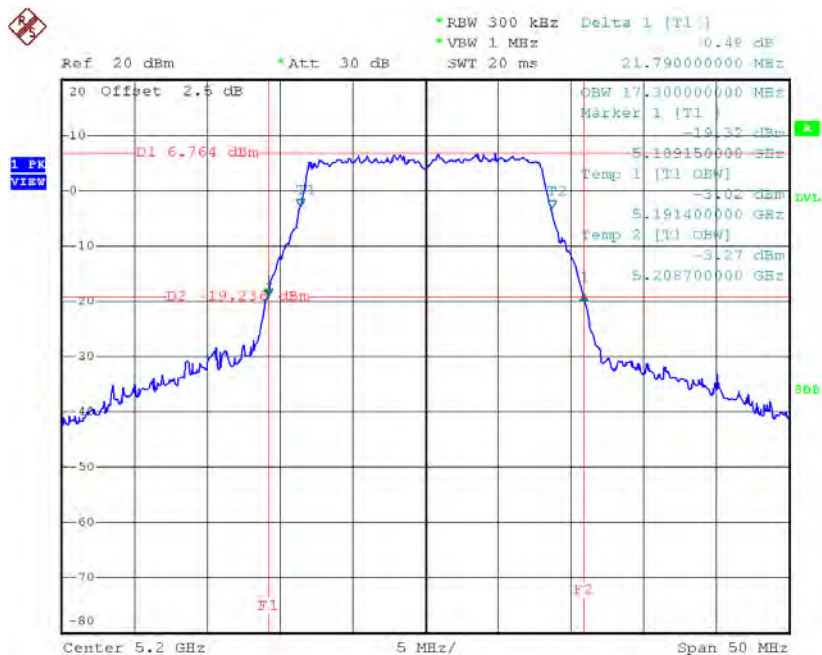

Date: 15.APR.2016 11:32:46

TX CH48

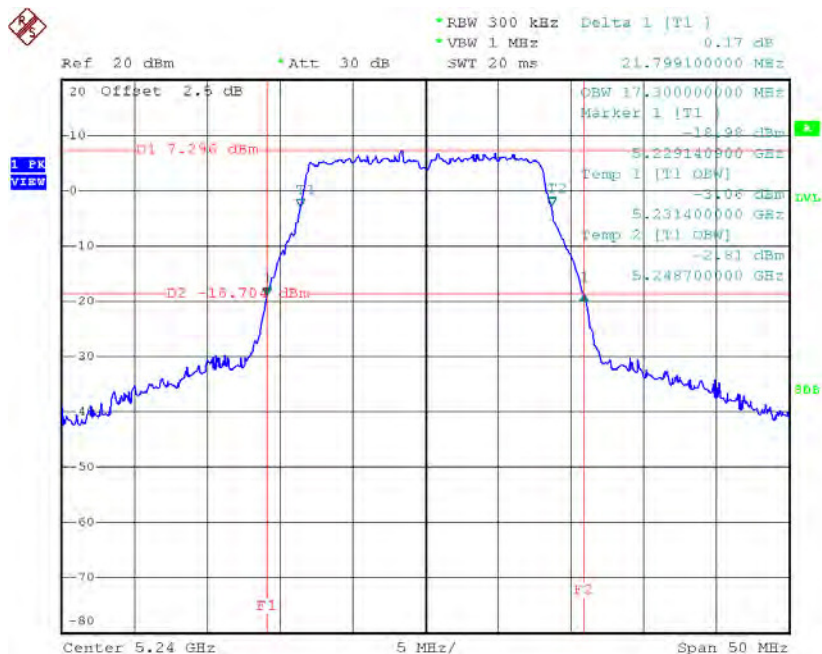

Date: 15.APR.2016 11:34:38

Test Mode: UNII-1/TX N20 Mode_CH36/CH40/CH48

Channel	Frequency (MHz)	26dB Bandwidth (MHz)	99% Occupied Bandwidth (MHz)
CH36	5180	22.20	18.40
CH40	5200	21.95	18.30
CH48	5240	22.05	18.40

TX CH36

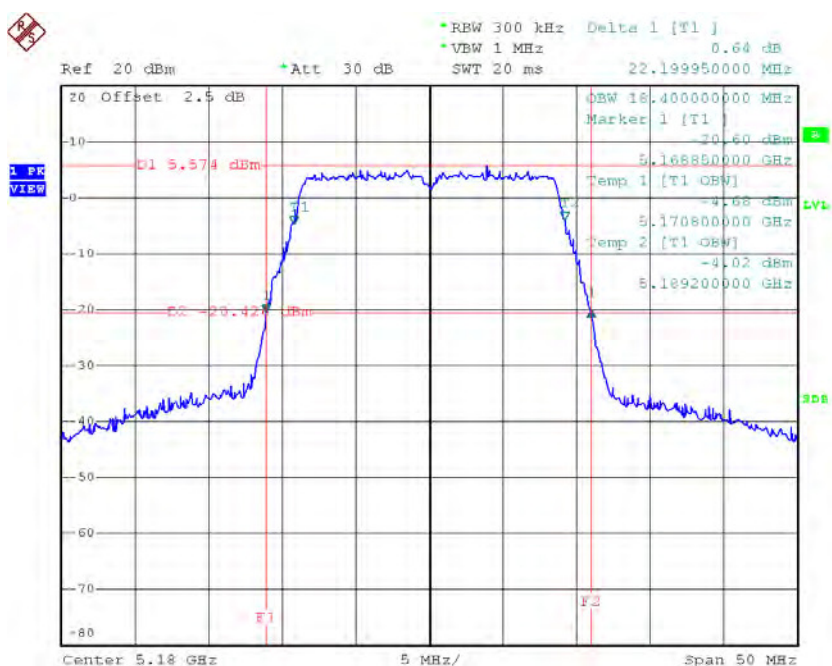

Date: 17.APR.2016 10:51:50

TX CH40

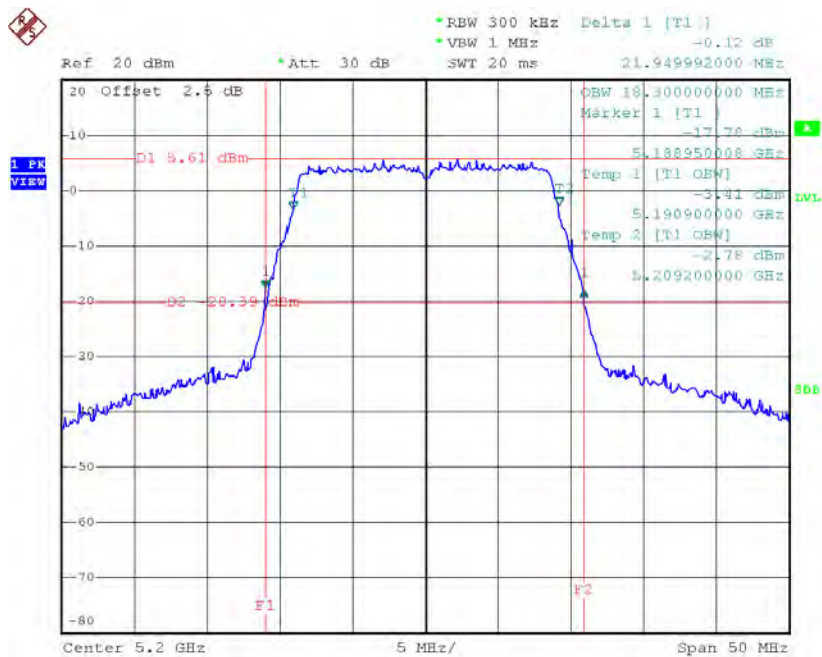

Date: 15.APR.2016 11:41:07

TX CH48

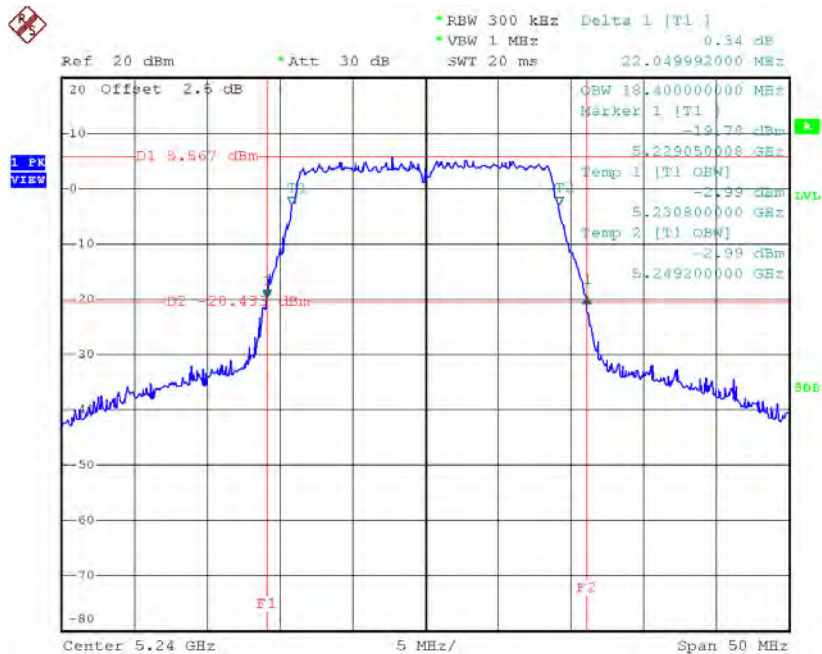

Date: 15.APR.2016 11:42:10

Test Mode: UNII-1/TX N40 Mode_CH38/CH46

Channel	Frequency (MHz)	26dB Bandwidth (MHz)	99% Occupied Bandwidth (MHz)
CH38	5190	40.00	36.40
CH46	5230	39.90	36.40

TX CH38

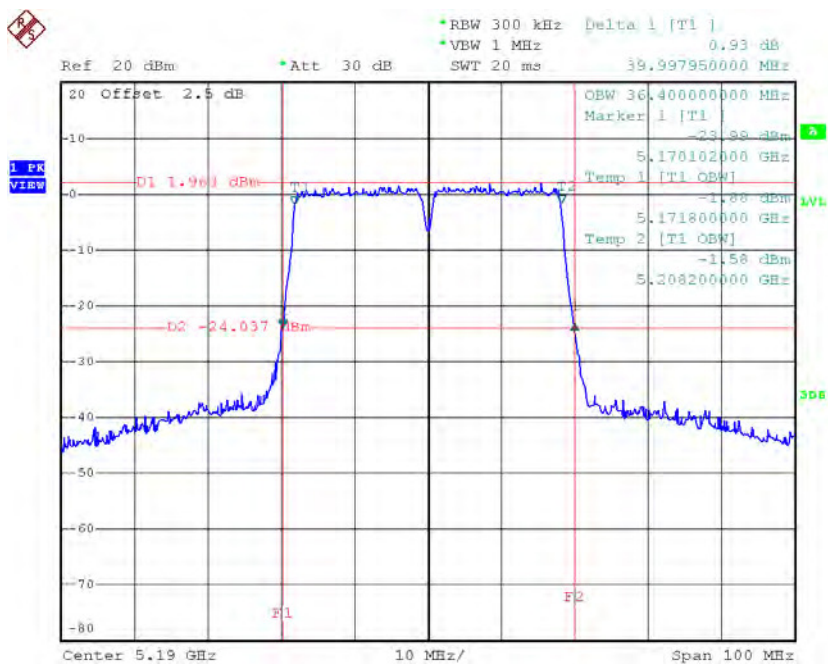

Date: 17.APR.2016 11:13:04

TX CH46

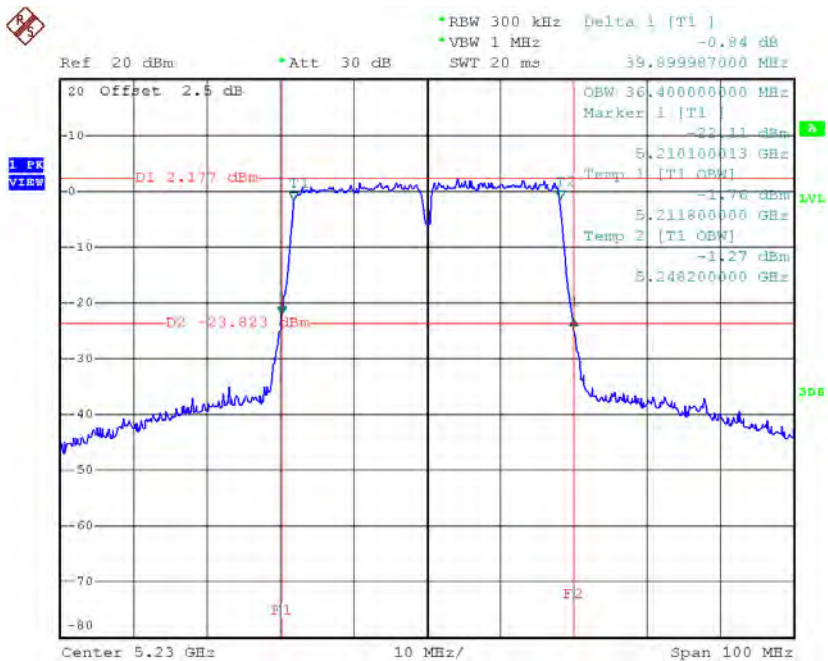

Date: 17.APR.2016 11:16:24

Test Mode: UNII-3/ TX A Mode_CH149/CH157/CH165

Channel	Frequency (MHz)	6dB Bandwidth (MHz)	99% Occupied Bandwidth (MHz)	Limit (kHz)
CH149	5745	16.51	16.60	>=500
CH157	5785	16.45	16.60	>=500
CH165	5825	16.45	16.60	>=500

TX CH 149

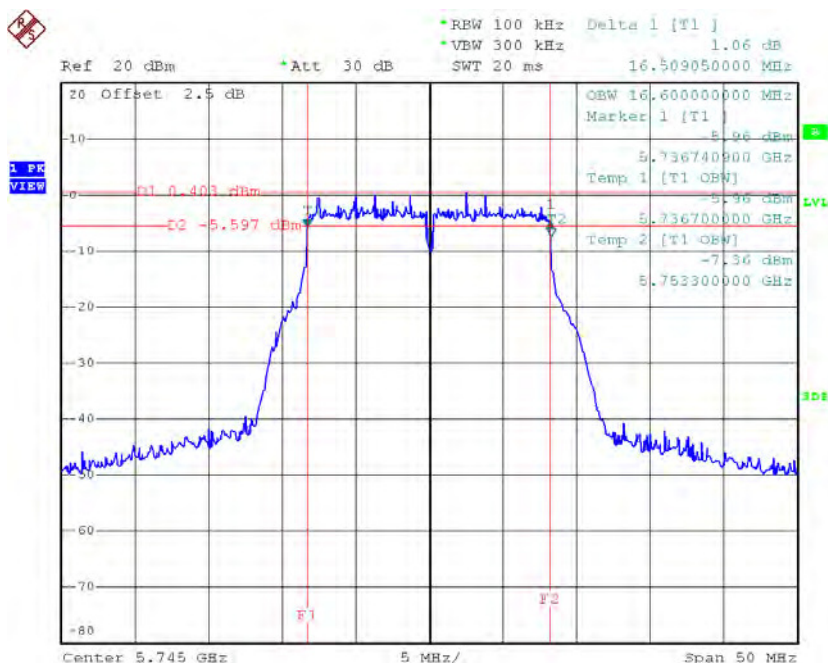

Date: 15.APR.2016 11:37:13

TX CH 157

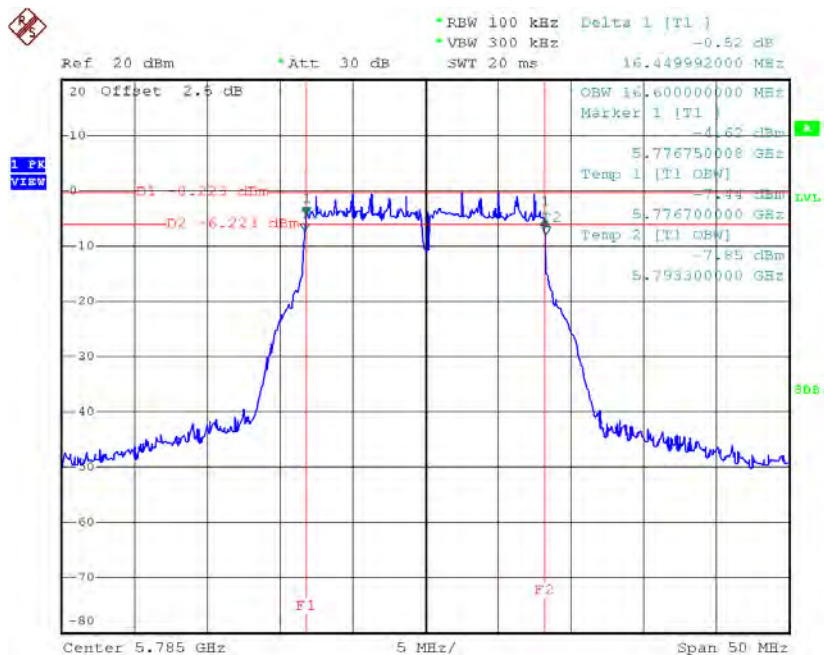

Date: 15.APR.2016 11:38:18

TX CH 165

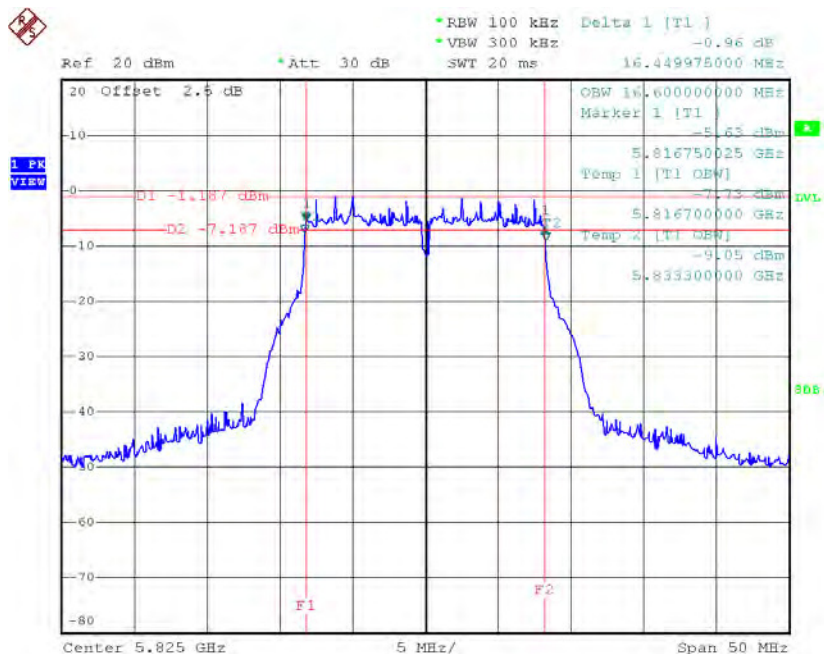

Date: 15.APR.2016 11:39:18

Test Mode: UNII-3/ TX N20 Mode_CH149/CH157/CH165

Channel	Frequency (MHz)	6dB Bandwidth (MHz)	99% Occupied Bandwidth (MHz)	Limit (kHz)
CH149	5745	17.65	17.80	>=500
CH157	5785	17.65	17.80	>=500
CH165	5825	17.65	17.80	>=500

TX CH 149

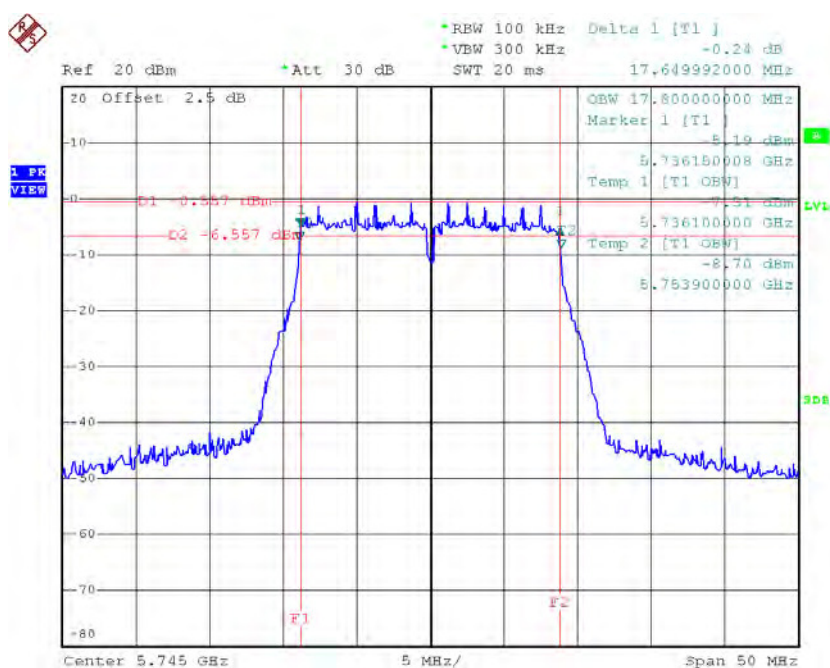

Date: 15.APR.2016 11:49:49

TX CH 157

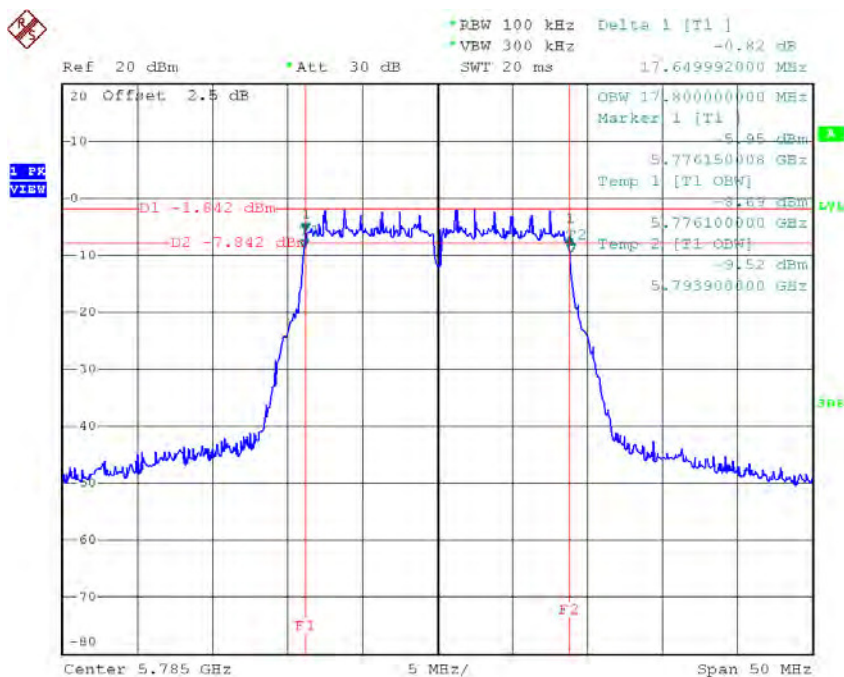

Date: 15.APR.2016 11:58:29

TX CH 165

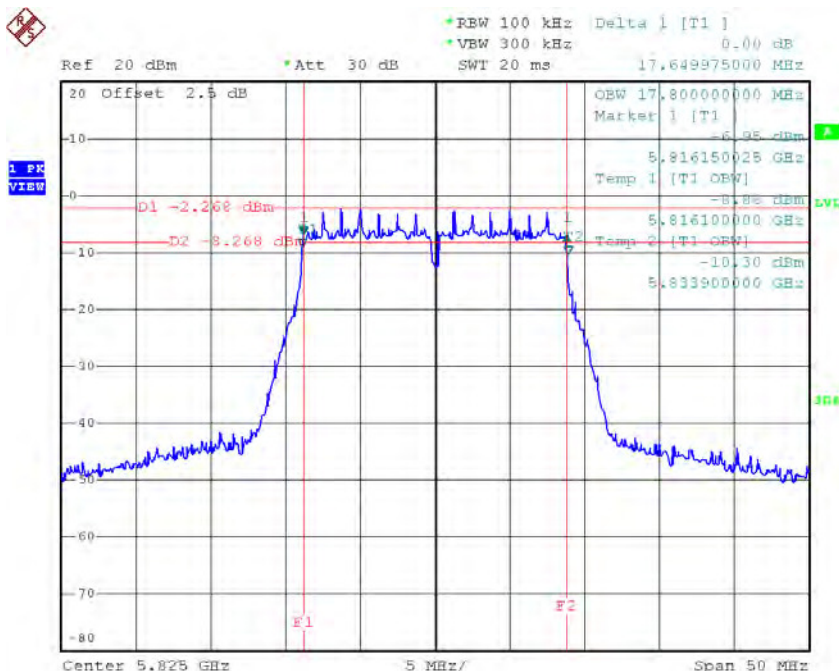

Date: 15.APR.2016 12:00:04

Test Mode: UNII-3/ TX N40 Mode_CH151/CH159

Channel	Frequency (MHz)	6dB Bandwidth (MHz)	99% Occupied Bandwidth (MHz)	Limit (kHz)
CH151	5755	36.50	36.40	>=500
CH159	5795	36.50	36.40	>=500

TX CH 151

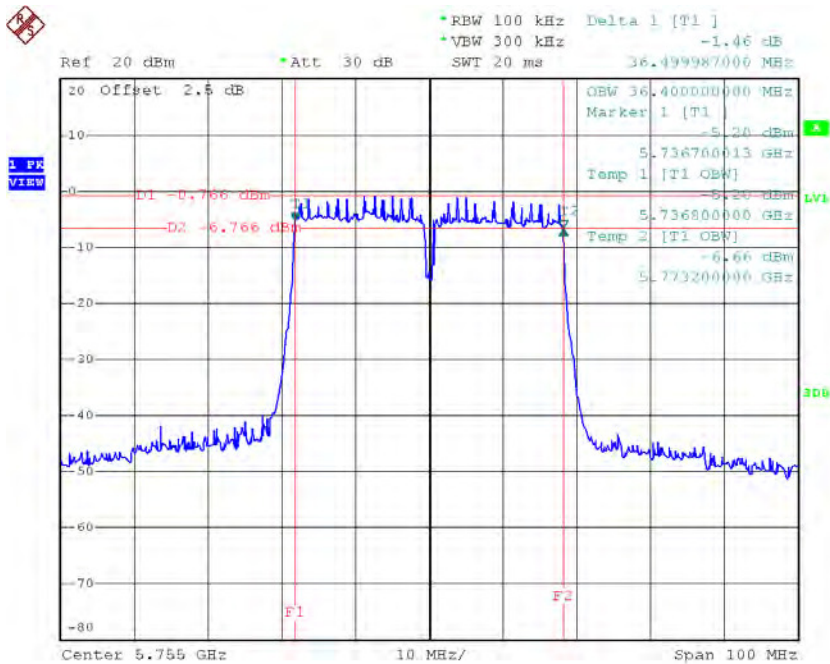

Date: 17.APR.2016 11:20:34

TX CH 159

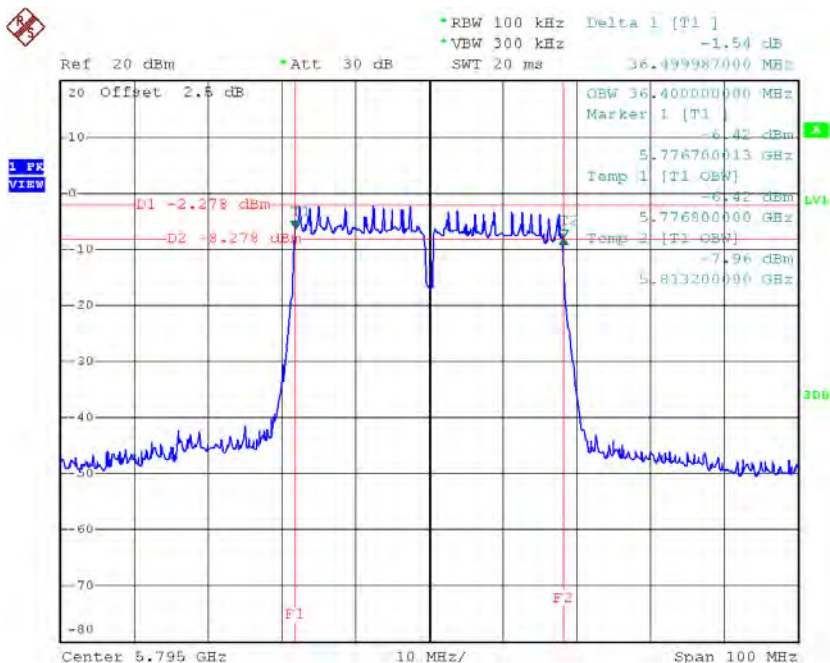

Date: 17.APR.2016 11:21:43

Test Mode: UNII-1/TX AC (VHT20MHz) Mode_CH36/CH40/CH48

Channel	Frequency (MHz)	26dB Bandwidth (MHz)	99% Occupied Bandwidth (MHz)
CH36	5180	22.09	18.40
CH40	5200	22.25	18.40
CH48	5240	21.99	18.30

TX CH36

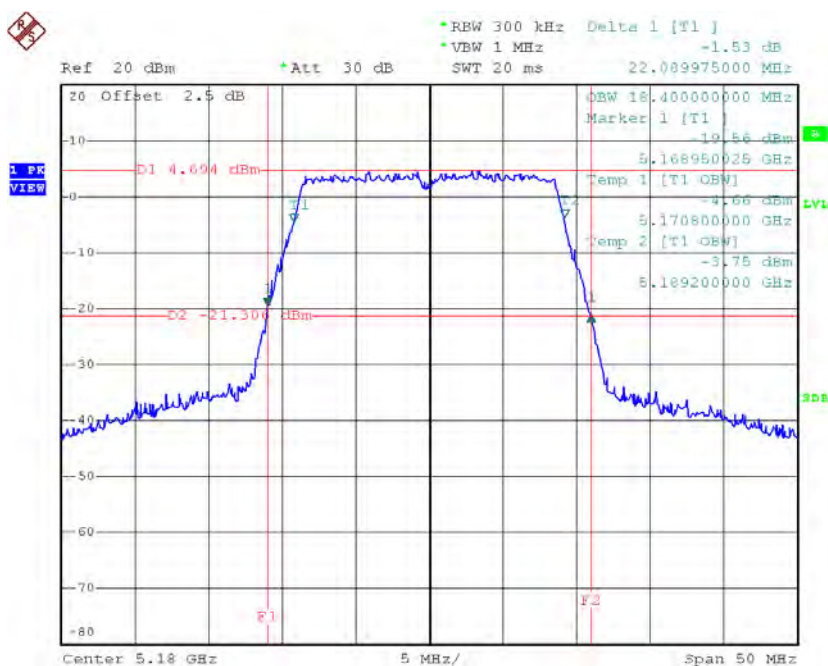

Date: 17.APR.2016 10:56:36

TX CH40

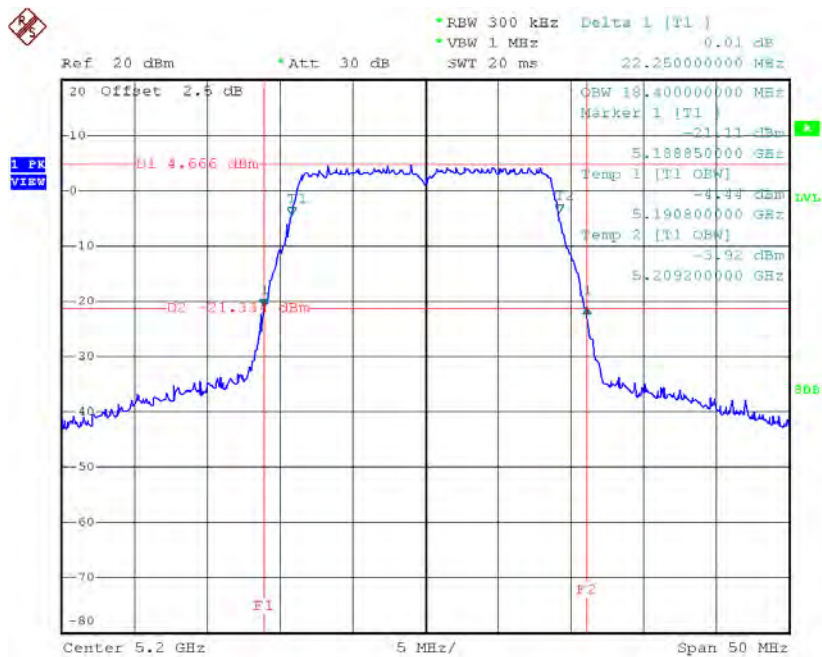

Date: 17.APR.2016 10:57:33

TX CH48

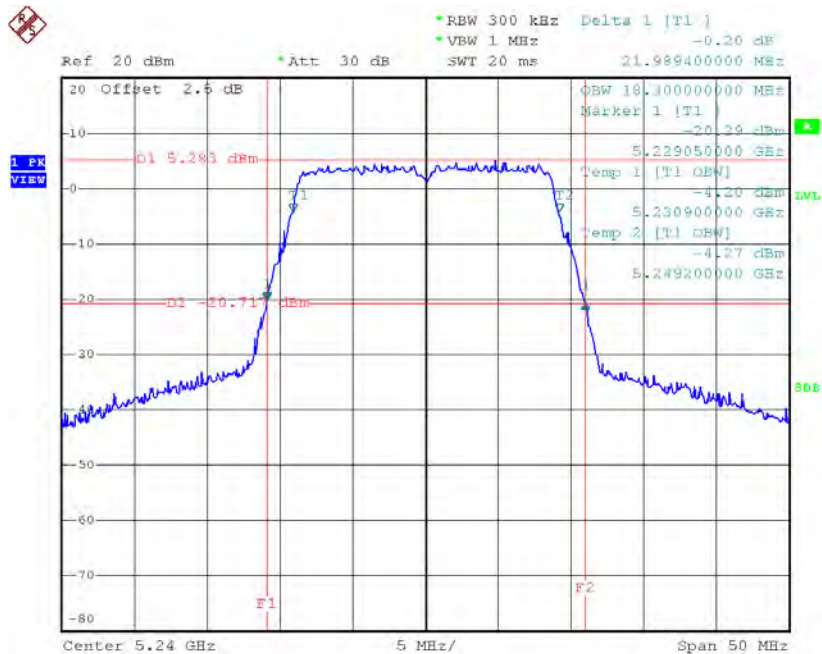

Date: 17.APR.2016 10:59:10

Test Mode: UNII-1/TX AC (VHT40MHz) Mode_CH38/CH46

Channel	Frequency (MHz)	26dB Bandwidth (MHz)	99% Occupied Bandwidth (MHz)
CH38	5190	40.01	36.40
CH46	5230	39.99	36.40

TX CH38

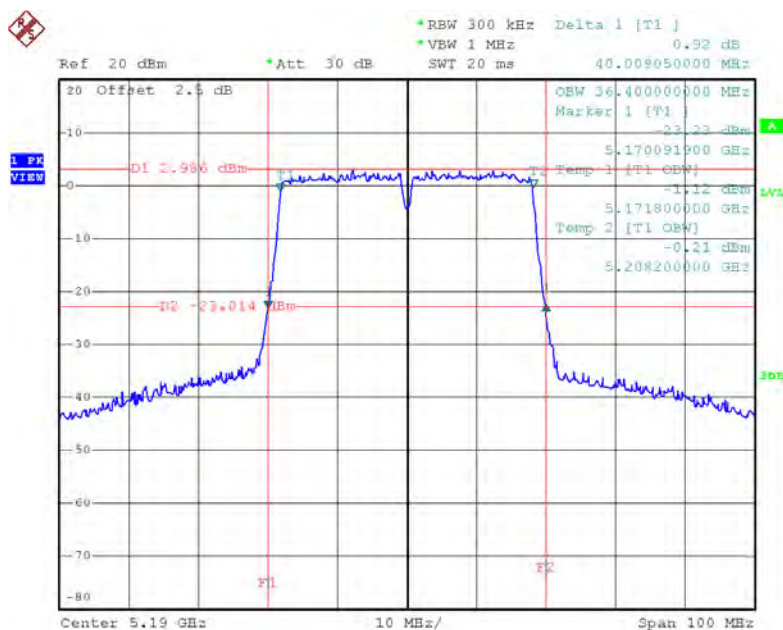

Date: 17.APR.2016 11:23:03

TX CH46

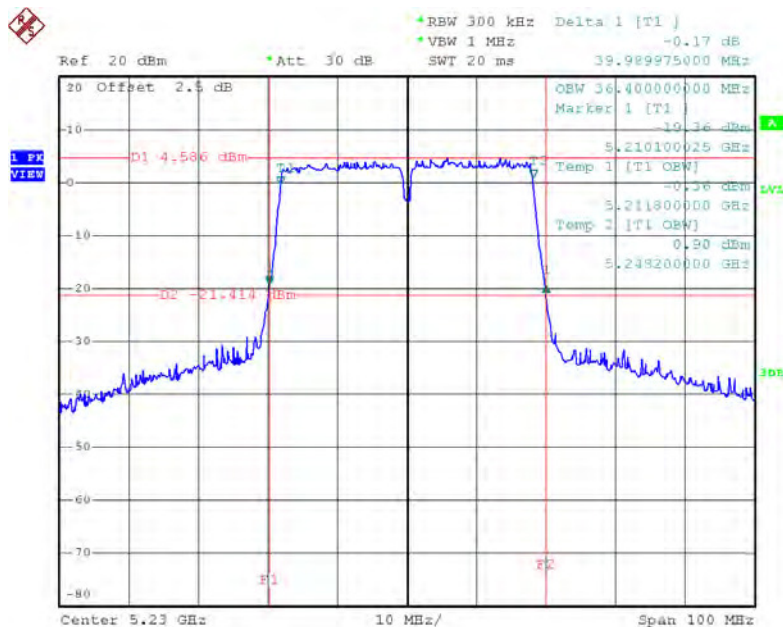

Date: 17.APR.2016 11:24:15

Test Mode: UNII-1/TX AC(VHT80) Mode_CH42

Channel	Frequency (MHz)	26dB Bandwidth (MHz)	99% Occupied Bandwidth (MHz)
CH42	5210	80.60	75.60

TX CH42

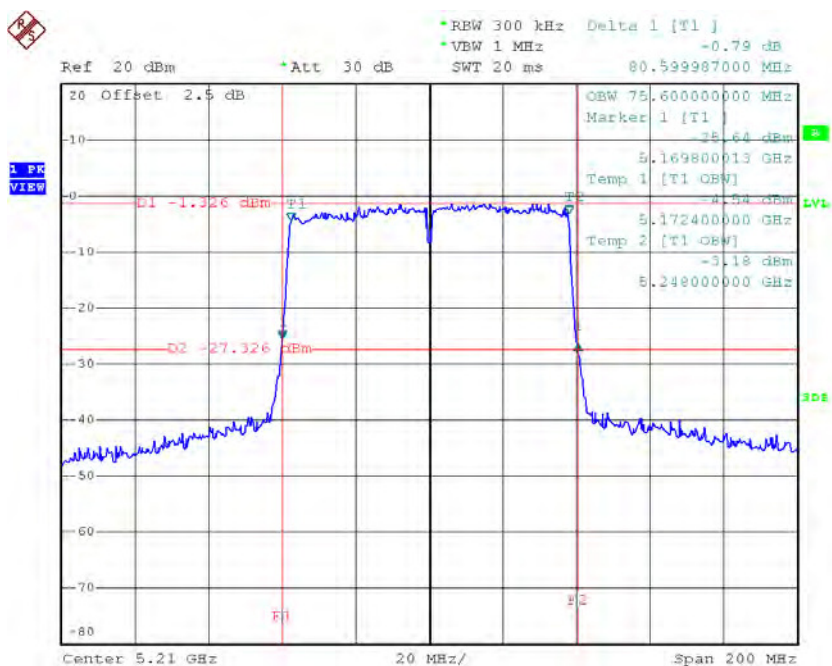

Date: 17.APR.2016 11:32:41

Test Mode: UNII-3/ TX AC (VHT20MHz) Mode_CH149/CH157/CH165

Channel	Frequency (MHz)	6dB Bandwidth (MHz)	99% Occupied Bandwidth (MHz)	Limit (kHz)
CH149	5745	17.65	17.80	>=500
CH157	5785	17.65	17.70	>=500
CH165	5825	17.65	17.80	>=500

TX CH 149

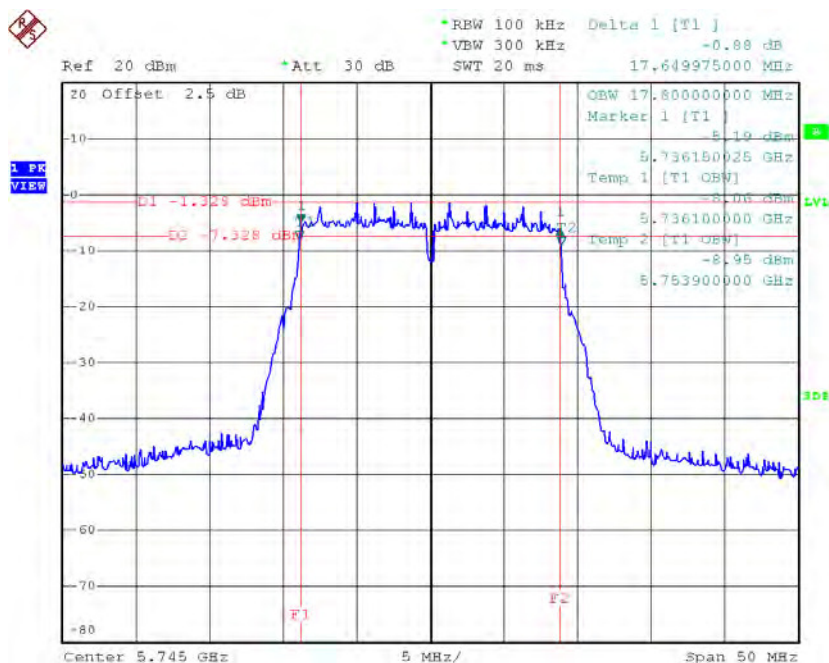

Date: 17.APR.2016 11:03:11

TX CH 157

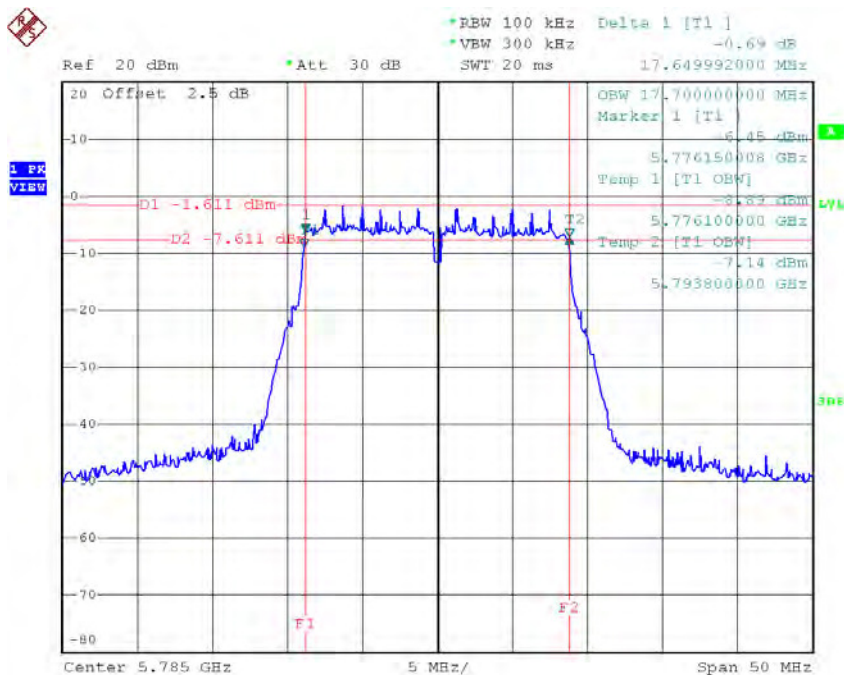

Date: 17.APR.2016 11:10:31

TX CH 165

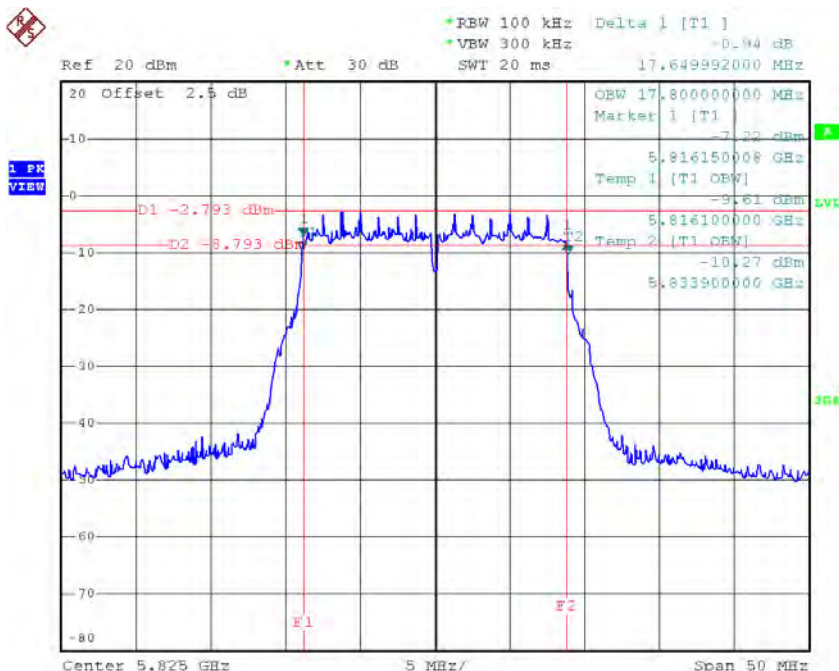

Date: 17.APR.2016 11:11:37

Test Mode: UNII-3/ TX AC (VHT40MHz) Mode_CH151/CH159

Channel	Frequency (MHz)	6dB Bandwidth (MHz)	99% Occupied Bandwidth (MHz)	Limit (kHz)
CH151	5755	36.50	36.40	>=500
CH159	5795	36.40	36.20	>=500

TX CH 151

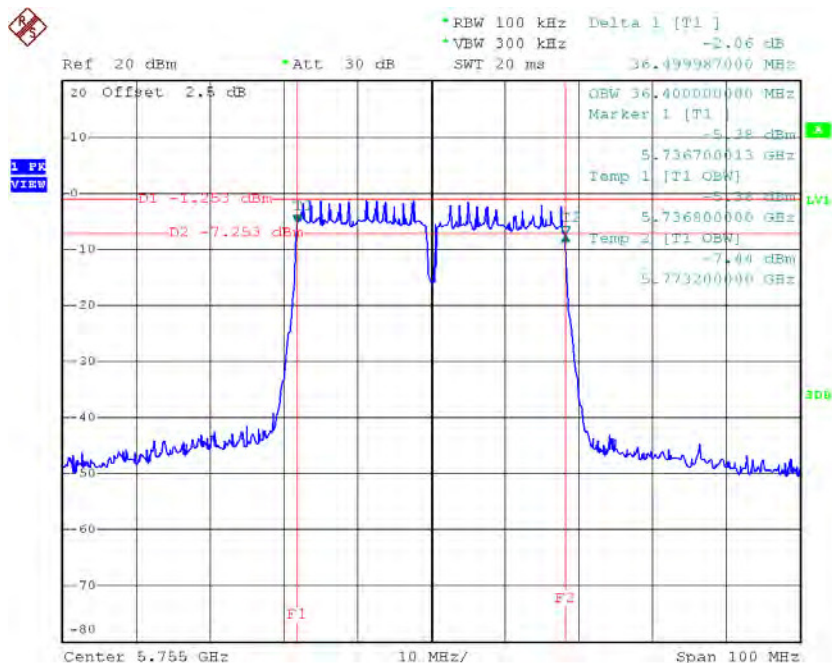

Date: 17.APR.2016 11:25:21

TX CH 159

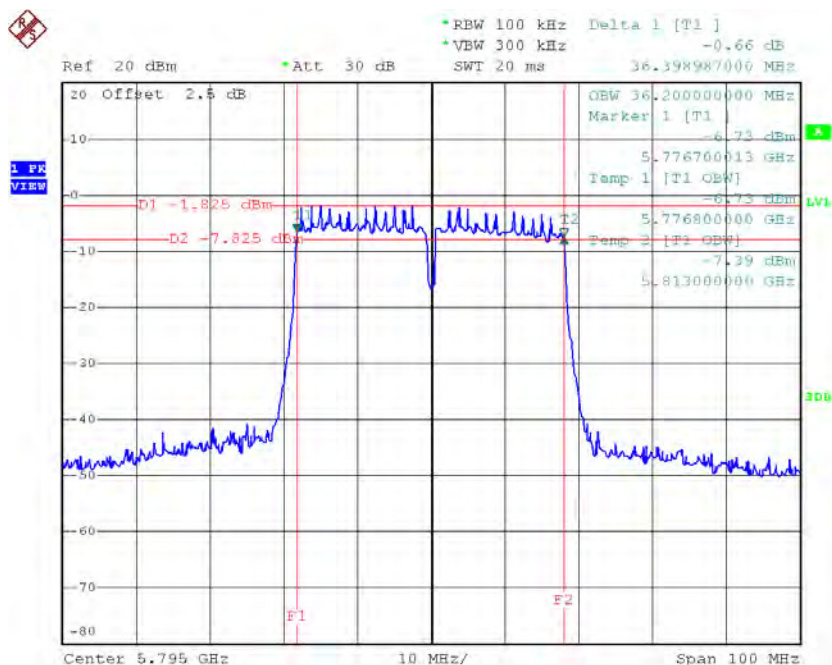

Date: 17.APR.2016 11:27:57

Test Mode: UNII-3/ TX AC(VHT80) Mode_CH155

Channel	Frequency (MHz)	6dB Bandwidth (MHz)	99% Occupied Bandwidth (MHz)	Limit (kHz)
CH155	5775	76.40	75.60	>=500

TX CH 155

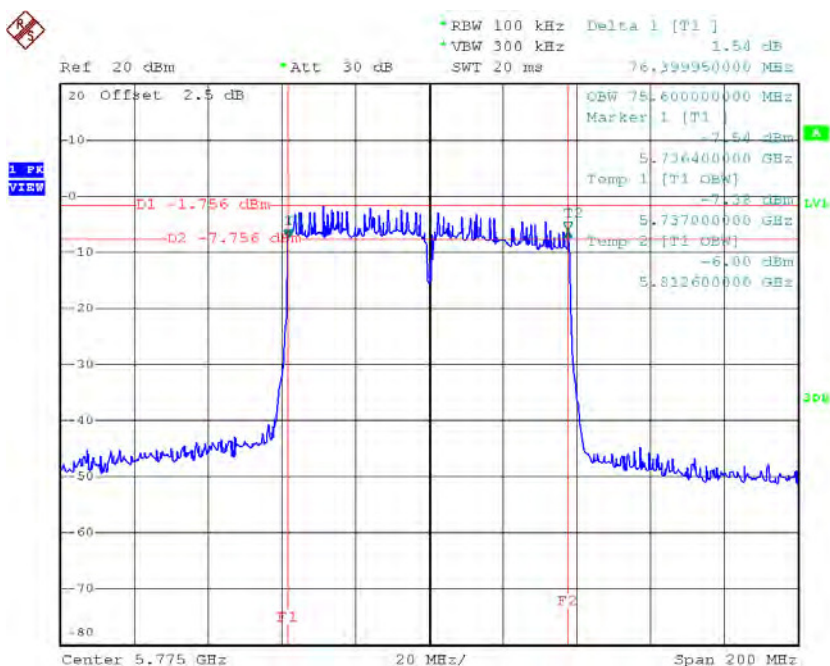

Date: 17.APR.2016 11:34:25

ATTACHMENT F - MAXIMUM OUTPUT POWER

Test Mode: UNII-1/TX A Mode

Channel	Frequency (MHz)	Output Power (dBm)	Duty Factor (dBm)	Output Power + Duty Factor (dBm)	Limit (dBm)	Limit (Watt)
CH36	5180	18.31	0.27	18.58	30.00	1.00
CH40	5200	18.29	0.27	18.56	30.00	1.00
CH48	5240	18.72	0.27	18.99	30.00	1.00

Test Mode: UNII-1/TX N20 Mode_ANT 1

Channel	Frequency (MHz)	Output Power (dBm)	Duty Factor (dBm)	Output Power + Duty Factor (dBm)	Limit (dBm)	Limit (Watt)
CH36	5180	16.12	0.51	16.63	30.00	1.00
CH40	5200	16.51	0.51	17.02	30.00	1.00
CH48	5240	16.22	0.51	16.73	30.00	1.00

Test Mode: UNII-1/TX N20 Mode_ANT 2

Channel	Frequency (MHz)	Output Power (dBm)	Duty Factor (dBm)	Output Power + Duty Factor (dBm)	Limit (dBm)	Limit (Watt)
CH36	5180	15.15	0.51	15.66	30.00	1.00
CH40	5200	15.98	0.51	16.49	30.00	1.00
CH48	5240	16.12	0.51	16.63	30.00	1.00

Test Mode: UNII-1/TX N20 Mode_Total

Channel	Frequency (MHz)	Output Power (dBm)	Duty Factor (dBm)	Output Power + Duty Factor (dBm)	Limit (dBm)	Limit (Watt)
CH36	5180	19.18	0.51	19.18	30.00	1.00
CH40	5200	19.77	0.51	19.77	30.00	1.00
CH48	5240	19.69	0.51	19.69	30.00	1.00

Test Mode: UNII-1/TX N40 Mode_ANT 1

Channel	Frequency (MHz)	Output Power (dBm)	Duty Factor (dBm)	Output Power + Duty Factor (dBm)	Limit (dBm)	Limit (Watt)
CH38	5190	14.52	1.35	15.87	30.00	1.00
CH46	5230	15.23	1.35	16.58	30.00	1.00

Test Mode: UNII-1/TX N40 Mode_ANT 2

Channel	Frequency (MHz)	Output Power (dBm)	Duty Factor (dBm)	Output Power + Duty Factor (dBm)	Limit (dBm)	Limit (Watt)
CH38	5190	13.61	1.35	14.96	30.00	1.00
CH46	5230	15.24	1.35	16.59	30.00	1.00

Test Mode: UNII-1/TX N40 Mode_Total

Channel	Frequency (MHz)	Output Power (dBm)	Limit (dBm)	Limit (Watt)
CH38	5190	18.45	30.00	1.00
CH46	5230	19.59	30.00	1.00

Test Mode: UNII-3/ TX A Mode

Channel	Frequency (MHz)	Output Power (dBm)	Duty Factor (dBm)	Output Power + Duty Factor (dBm)	Limit (dBm)	Limit (Watt)
CH149	5745	13.62	0.27	13.89	30.00	1.00
CH157	5785	13.35	0.27	13.62	30.00	1.00
CH165	5825	12.57	0.27	12.84	30.00	1.00

Test Mode: UNII-3/TX N20 Mode_ANT 1

Channel	Frequency (MHz)	Output Power (dBm)	Duty Factor (dBm)	Output Power + Duty Factor (dBm)	Limit (dBm)	Limit (Watt)
CH149	5745	12.05	0.51	12.56	30.00	1.00
CH157	5785	11.84	0.51	12.35	30.00	1.00
CH165	5825	10.89	0.51	11.40	30.00	1.00

Test Mode: UNII-3/TX N20 Mode_ANT 2

Channel	Frequency (MHz)	Output Power (dBm)	Duty Factor (dBm)	Output Power + Duty Factor (dBm)	Limit (dBm)	Limit (Watt)
CH149	5745	12.97	0.51	13.48	30.00	1.00
CH157	5785	12.17	0.51	12.68	30.00	1.00
CH165	5825	10.82	0.51	11.33	30.00	1.00

Test Mode: UNII-3/TX N20 Mode_Total

Channel	Frequency (MHz)	Output Power (dBm)	Limit (dBm)	Limit (Watt)
CH149	5745	16.05	30.00	1.00
CH157	5785	15.53	30.00	1.00
CH165	5825	14.38	30.00	1.00

Test Mode: UNII-3/ TX N40 Mode_ANT 1

Channel	Frequency (MHz)	Output Power (dBm)	Duty Factor (dBm)	Output Power + Duty Factor (dBm)	Limit (dBm)	Limit (Watt)
CH151	5755	14.12	1.35	15.47	30.00	1.00
CH159	5795	13.18	1.35	14.53	30.00	1.00

Test Mode: UNII-3/ TX N40 Mode_ANT 2

Channel	Frequency (MHz)	Output Power (dBm)	Duty Factor (dBm)	Output Power + Duty Factor (dBm)	Limit (dBm)	Limit (Watt)
CH151	5755	13.63	1.35	14.98	30.00	1.00
CH159	5795	12.55	1.35	13.90	30.00	1.00

Test Mode: UNII-3/ TX N40 Mode_Total

Channel	Frequency (MHz)	Output Power (dBm)	Limit (dBm)	Limit (Watt)
CH151	5755	18.24	30.00	1.00
CH159	5795	17.24	30.00	1.00

Test Mode: UNII-1/TX AC (VHT20MHz) Mode_ANT 1

Channel	Frequency (MHz)	Output Power (dBm)	Duty Factor (dBm)	Output Power + Duty Factor (dBm)	Limit (dBm)	Limit (Watt)
CH36	5180	16.18	0.22	16.40	30.00	1.00
CH40	5200	15.93	0.22	16.15	30.00	1.00
CH48	5240	16.32	0.22	16.54	30.00	1.00

Test Mode: UNII-1/TX AC (VHT20MHz) Mode_ANT 2

Channel	Frequency (MHz)	Output Power (dBm)	Duty Factor (dBm)	Output Power + Duty Factor (dBm)	Limit (dBm)	Limit (Watt)
CH36	5180	14.78	0.22	15.00	30.00	1.00
CH40	5200	15.37	0.22	15.59	30.00	1.00
CH48	5240	16.11	0.22	16.33	30.00	1.00

Test Mode: UNII-1/TX AC (VHT20MHz) Mode_Total

Channel	Frequency (MHz)	Output Power (dBm)	Limit (dBm)	Limit (Watt)
CH36	5180	18.77	30.00	1.00
CH40	5200	18.89	30.00	1.00
CH48	5240	19.45	30.00	1.00

Test Mode: UNII-1/TX AC (VHT40MHz) Mode_ANT 1

Channel	Frequency (MHz)	Output Power (dBm)	Duty Factor (dBm)	Output Power + Duty Factor (dBm)	Limit (dBm)	Limit (Watt)
CH38	5190	16.09	0.89	16.98	30.00	1.00
CH46	5230	16.08	0.89	16.97	30.00	1.00

Test Mode: UNII-1/TX AC (VHT40MHz) Mode_ANT 2

Channel	Frequency (MHz)	Output Power (dBm)	Duty Factor (dBm)	Output Power + Duty Factor (dBm)	Limit (dBm)	Limit (Watt)
CH38	5190	16.02	0.89	16.91	30.00	1.00
CH46	5230	15.98	0.89	16.87	30.00	1.00

Test Mode: UNII-1/TX AC (VHT40MHz) Mode_Total

Channel	Frequency (MHz)	Output Power (dBm)	Limit (dBm)	Limit (Watt)
CH38	5190	19.95	30.00	1.00
CH46	5230	19.93	30.00	1.00

Test Mode: UNII-1/TX AC(VHT80) Mode_ANT 1

Channel	Frequency (MHz)	Output Power (dBm)	Duty Factor (dBm)	Output Power + Duty Factor (dBm)	Limit (dBm)	Limit (Watt)
CH42	5210	16.21	1.05	17.26	30.00	1.00

Test Mode: UNII-1/TX AC(VHT80) Mode_ANT 2

Channel	Frequency (MHz)	Output Power (dBm)	Duty Factor (dBm)	Output Power + Duty Factor (dBm)	Limit (dBm)	Limit (Watt)
CH42	5210	15.41	1.05	16.46	30.00	1.00

Test Mode: UNII-1/TX AC(VHT80) Mode_Total

Channel	Frequency (MHz)	Output Power (dBm)	Limit (dBm)	Limit (Watt)
CH42	5210	19.89	30.00	1.00

Test Mode: UNII-3/TX AC (VHT20MHz) Mode_ANT 1

Channel	Frequency (MHz)	Output Power (dBm)	Duty Factor (dBm)	Output Power + Duty Factor (dBm)	Limit (dBm)	Limit (Watt)
CH149	5745	11.33	0.22	11.55	30.00	1.00
CH157	5785	10.91	0.22	11.13	30.00	1.00
CH165	5825	10.42	0.22	10.64	30.00	1.00

Test Mode: UNII-3/TX AC (VHT20MHz) Mode_ANT 2

Channel	Frequency (MHz)	Output Power (dBm)	Duty Factor (dBm)	Output Power + Duty Factor (dBm)	Limit (dBm)	Limit (Watt)
CH149	5745	12.67	0.22	12.89	30.00	1.00
CH157	5785	11.72	0.22	11.94	30.00	1.00
CH165	5825	10.82	0.22	11.04	30.00	1.00

Test Mode: UNII-3/TX AC (VHT20MHz) Mode_Total

Channel	Frequency (MHz)	Output Power (dBm)	Limit (dBm)	Limit (Watt)
CH149	5745	15.28	30.00	1.00
CH157	5785	14.56	30.00	1.00
CH165	5825	13.85	30.00	1.00

Test Mode: UNII-3/TX AC (VHT40MHz) Mode_ANT 1

Channel	Frequency (MHz)	Output Power (dBm)	Duty Factor (dBm)	Output Power + Duty Factor (dBm)	Limit (dBm)	Limit (Watt)
CH151	5755	14.29	0.89	15.18	30.00	1.00
CH159	5795	14.07	0.89	14.96	30.00	1.00

Test Mode: UNII-3/TX AC (VHT40MHz) Mode_ANT 2

Channel	Frequency (MHz)	Output Power (dBm)	Duty Factor (dBm)	Output Power + Duty Factor (dBm)	Limit (dBm)	Limit (Watt)
CH151	5755	13.53	0.89	14.42	30.00	1.00
CH159	5795	13.11	0.89	14.00	30.00	1.00

Test Mode: UNII-3/TX AC (VHT40MHz) Mode_Total

Channel	Frequency (MHz)	Output Power (dBm)	Limit (dBm)	Limit (Watt)
CH151	5755	17.83	30.00	1.00
CH159	5795	17.52	30.00	1.00

Test Mode: UNII-3/TX AC(VHT80) Mode_ANT 1

Channel	Frequency (MHz)	Output Power (dBm)	Duty Factor (dBm)	Output Power + Duty Factor (dBm)	Limit (dBm)	Limit (Watt)
CH155	5775	15.84	1.05	16.89	30.00	1.00

Test Mode: UNII-3/TX AC(VHT80) Mode_ANT 2

Channel	Frequency (MHz)	Output Power (dBm)	Duty Factor (dBm)	Output Power + Duty Factor (dBm)	Limit (dBm)	Limit (Watt)
CH155	5775	15.74	1.05	16.79	30.00	1.00

Test Mode: UNII-3/TX AC(VHT80) Mode_Total

Channel	Frequency (MHz)	Output Power (dBm)	Limit (dBm)	Limit (Watt)
CH155	5775	19.85	30.00	1.00

ATTACHMENT G - POWER SPECTRAL DENSITY

Test Mode: UNII-1/ TX A Mode_CH36/CH40/CH48

Channel	Frequency (MHz)	Power Density (dBm/MHz)	Duty Factor (dBm/MHz)	Power Density + Duty Factor (dBm/MHz)	Limit (dBm/MHz)
CH36	5180	2.83	0.27	3.10	17.00
CH40	5200	2.85	0.27	3.12	17.00
CH48	5240	3.65	0.27	3.92	17.00

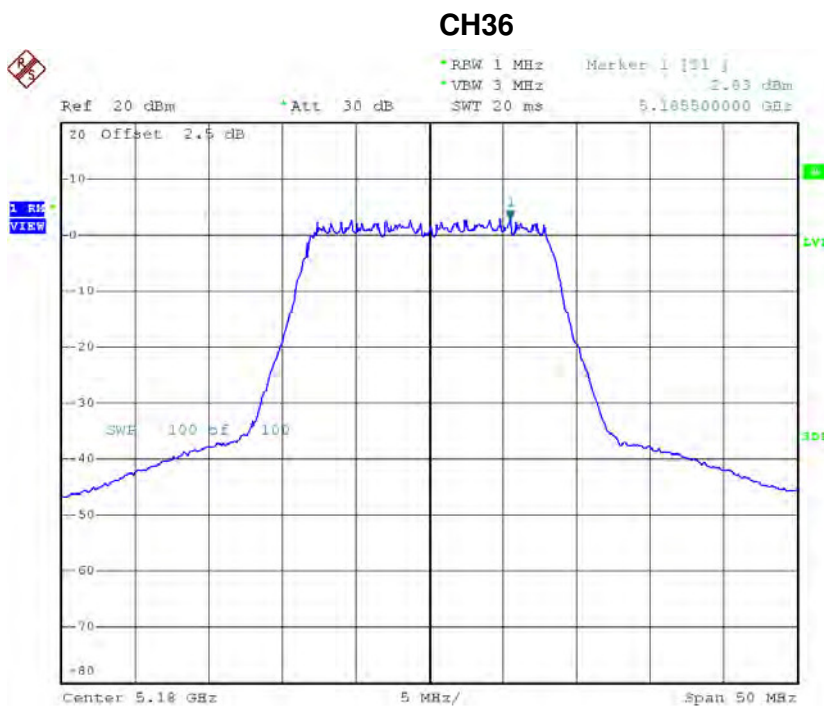

Date: 15.APR.2016 10:41:18

CH40

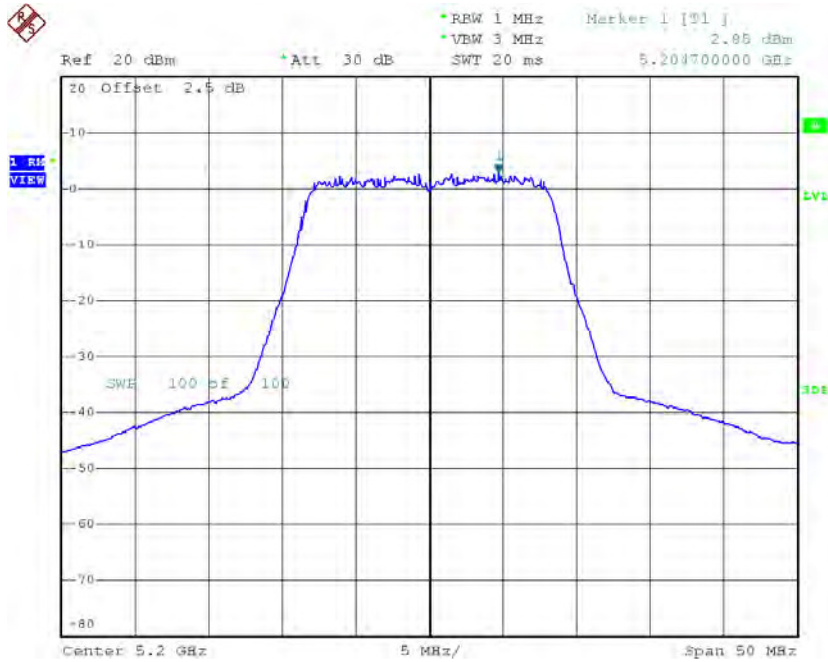

Date: 15.APR.2016 10:41:46

CH48

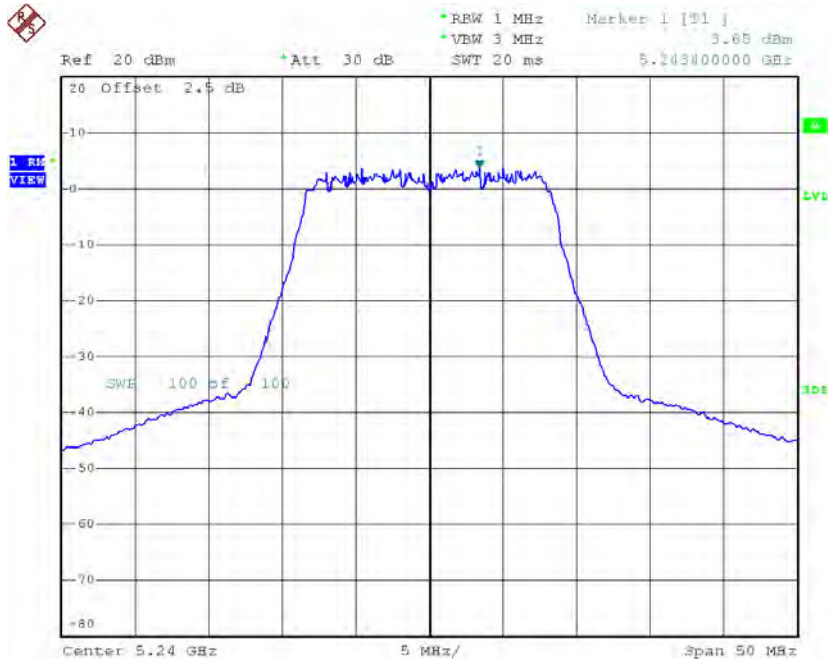

Date: 15.APR.2016 10:42:14

Test Mode: UNII-3/TX A Mode_CH149/CH157/CH165

Channel	Frequency (MHz)	Power Density (dBm/500kHz)	Duty Factor (dBm/MHz)	Power Density + Duty Factor (dBm/500kHz)	Limit (dBm/500kHz)
CH149	5745	-3.10	0.27	-2.83	30.00
CH157	5785	-4.49	0.27	-4.22	30.00
CH165	5825	-4.82	0.27	-4.55	30.00

TX CH149

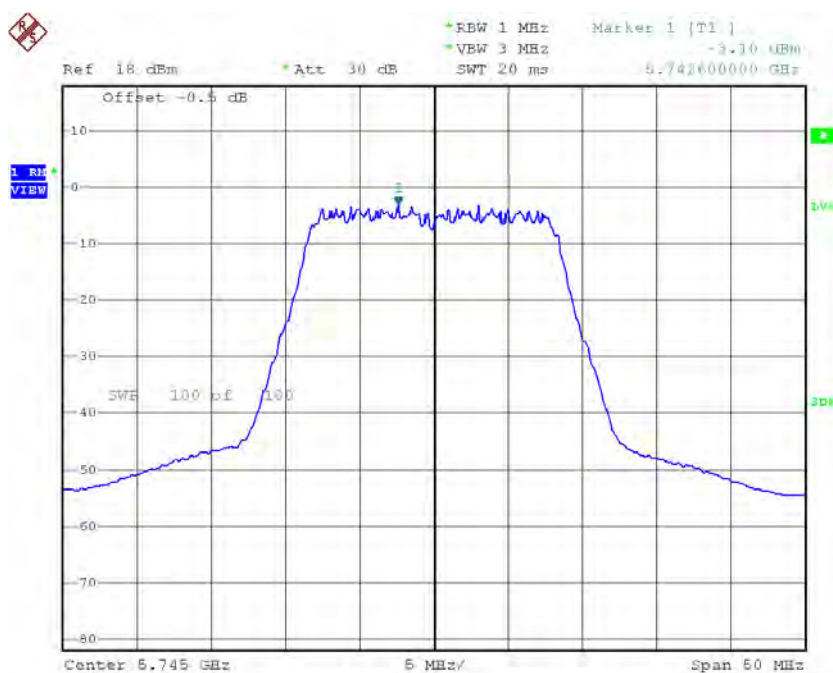

Date: 15.APR.2016 10:46:00

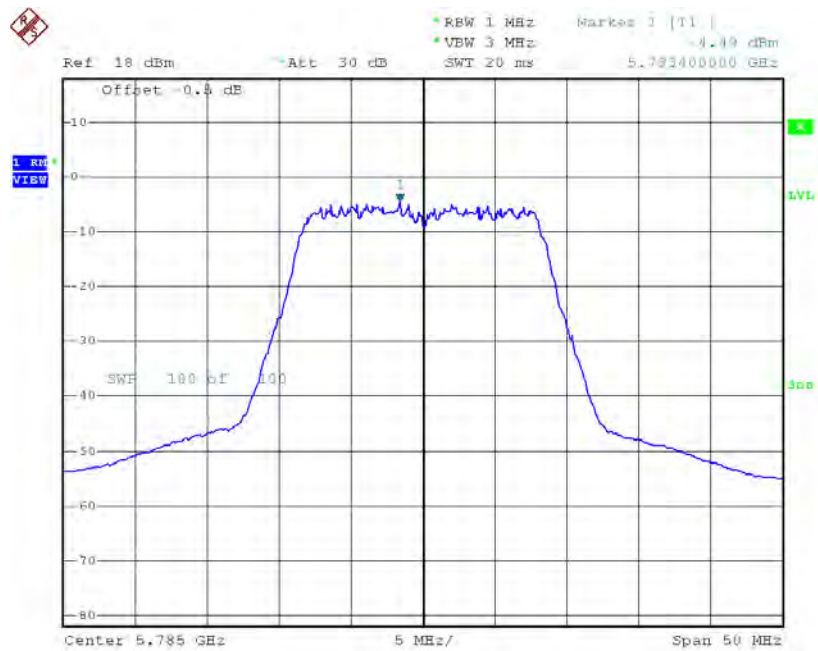
TX CH157

Date: 15.APR.2016 10:46:21

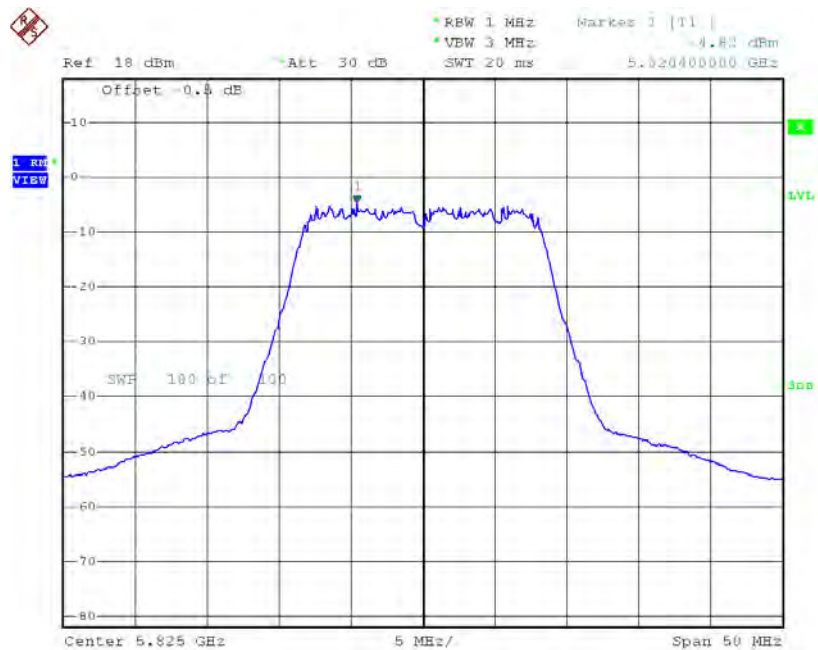
TX CH165

Date: 15.APR.2016 10:46:45

Test Mode: UNII-1/TX N20 Mode_CH36/CH40/CH48_ANT 1

Channel	Frequency (MHz)	Power Density (dBm/MHz)	Duty Factor (dBm/MHz)	Power Density + Duty Factor (dBm/MHz)	Limit (dBm/MHz)
CH36	5180	0.58	0.51	1.09	17.00
CH40	5200	1.01	0.51	1.52	17.00
CH48	5240	0.80	0.51	1.31	17.00

CH36

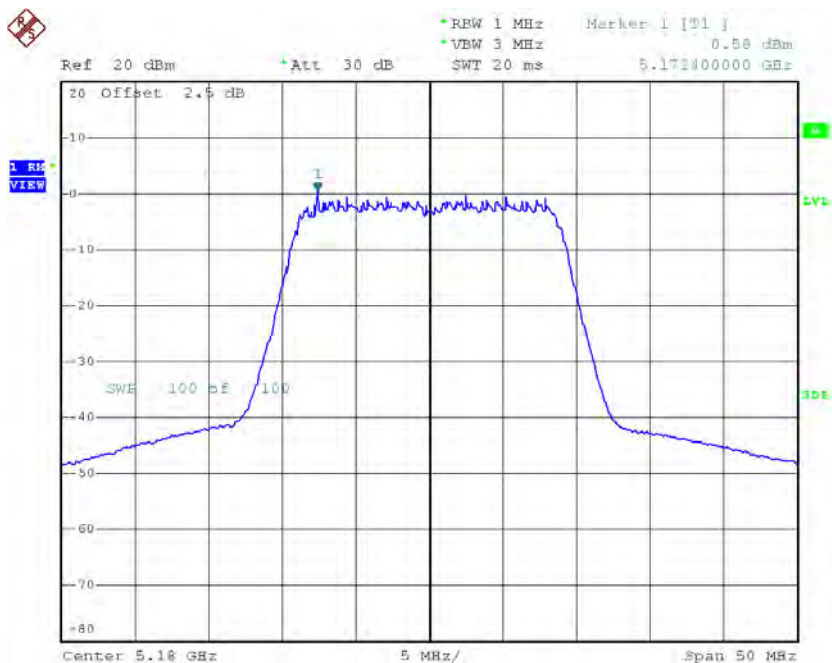

Date: 17.APR.2016 10:51:59

CH40

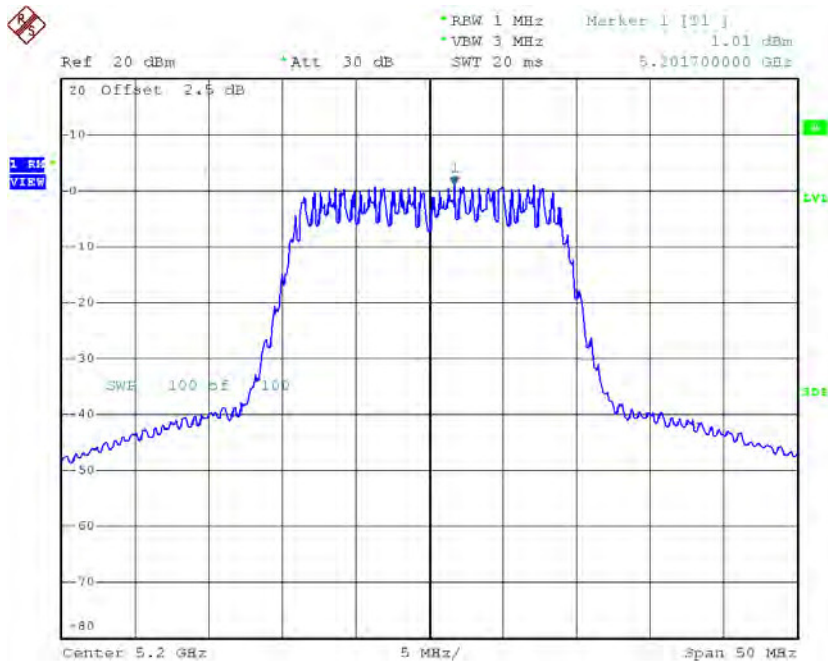

Date: 15.APR.2016 11:41:17

CH48

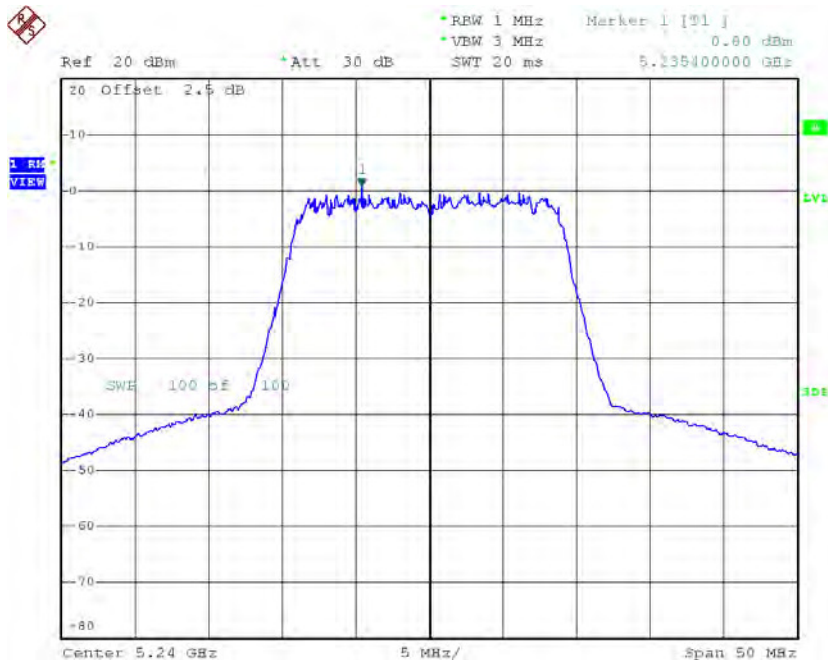

Date: 15.APR.2016 11:42:19

Test Mode: UNII-1/TX N20 Mode_CH36/CH40/CH48_ANT 2

Channel	Frequency (MHz)	Power Density (dBm/MHz)	Duty Factor (dBm/MHz)	Power Density + Duty Factor (dBm/MHz)	Limit (dBm/MHz)
CH36	5180	0.21	0.51	0.72	17.00
CH40	5200	1.03	0.51	1.54	17.00
CH48	5240	2.20	0.51	2.71	17.00

CH36

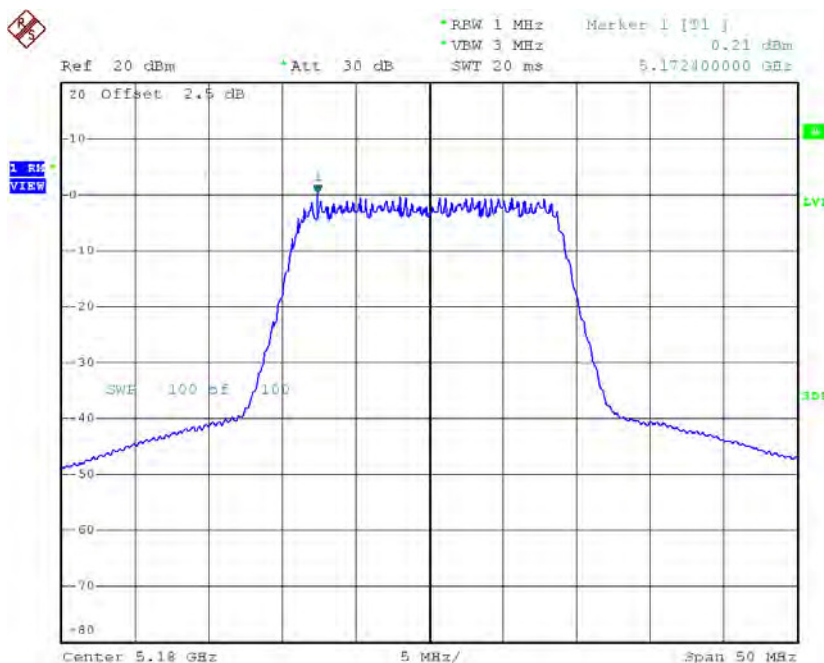

Date: 17.APR.2016 11:38:13

CH40

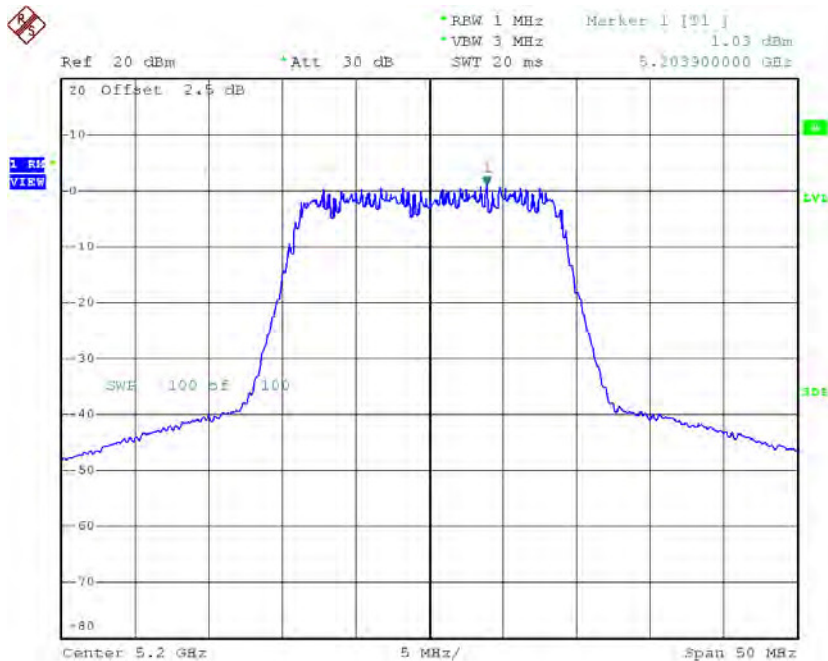

Date: 17.APR.2016 11:39:17

CH48

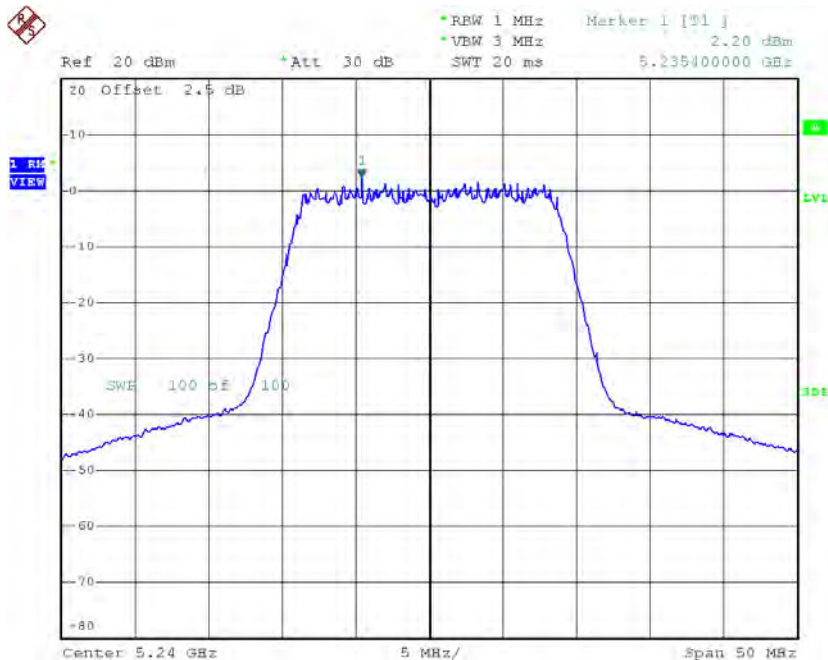

Date: 17.APR.2016 11:40:19

Test Mode: UNII-1/TX N20 Mode_CH36/CH40/CH48_Total

Channel	Frequency (MHz)	Power Density (dBm/MHz)	Limit (dBm/MHz)
CH36	5180	3.92	17.00
CH40	5200	4.54	17.00
CH48	5240	5.08	17.00

Test Mode: UNII-1/TX N40 Mode_CH38/CH46_ANT 1

Channel	Frequency (MHz)	Power Density (dBm/MHz)	Duty Factor (dBm/MHz)	Power Density + Duty Factor (dBm/MHz)	Limit (dBm/MHz)
CH38	5190	-3.62	1.35	-2.27	17.00
CH46	5230	-2.49	1.35	-1.14	17.00

CH38

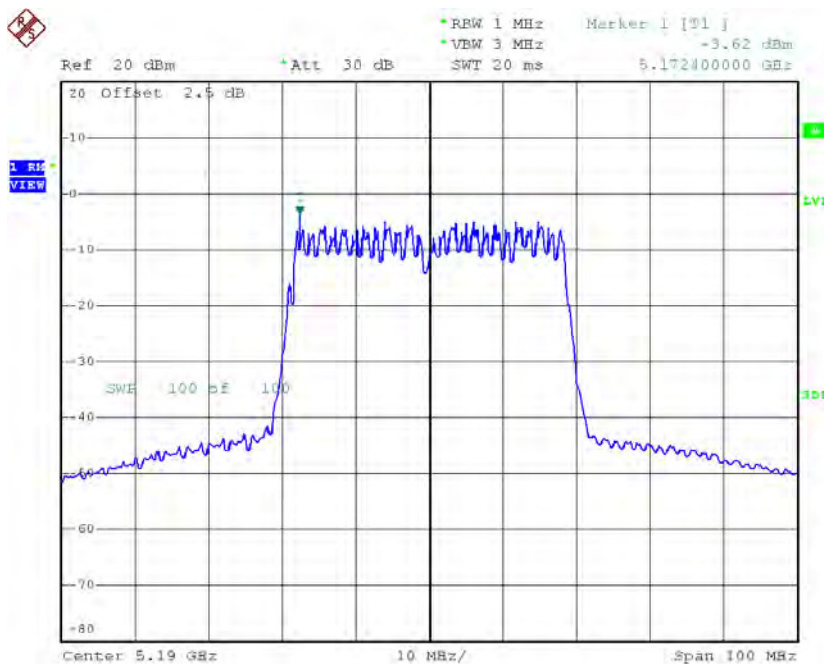

Date: 17.APR.2016 11:13:13

CH46

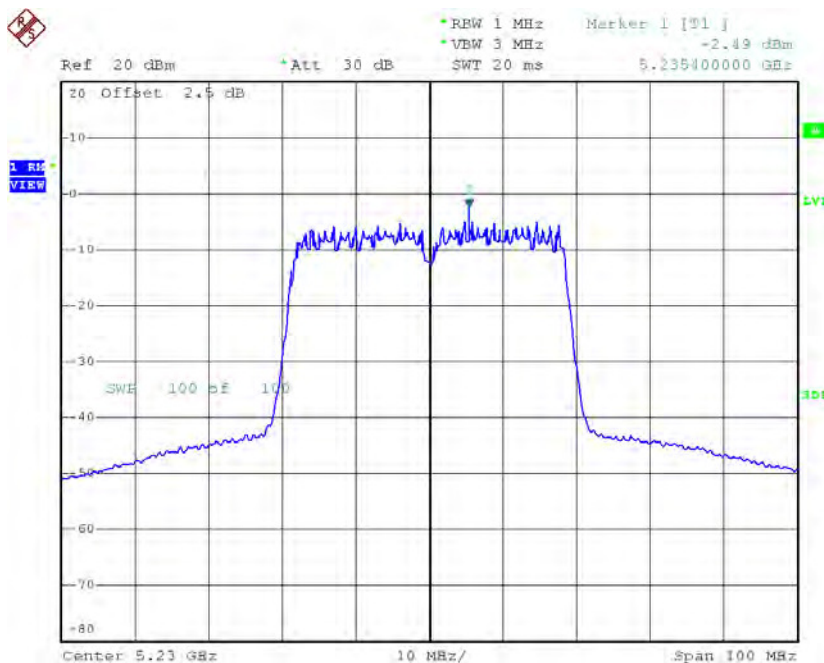

Date: 17.APR.2016 11:16:34

Test Mode: UNII-1/TX N40 Mode_CH38/CH46_ANT 2

Channel	Frequency (MHz)	Power Density (dBm/MHz)	Duty Factor (dBm/MHz)	Power Density + Duty Factor (dBm/MHz)	Limit (dBm/MHz)
CH38	5190	-3.59	1.35	-2.24	17.00
CH46	5230	-0.84	1.35	0.51	17.00

CH38

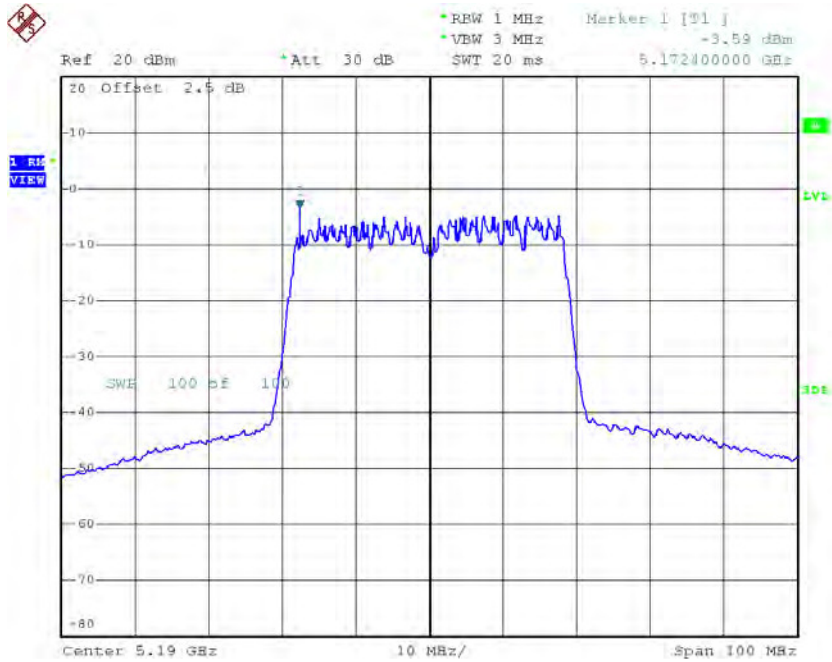

Date: 17.APR.2016 12:12:11

CH46

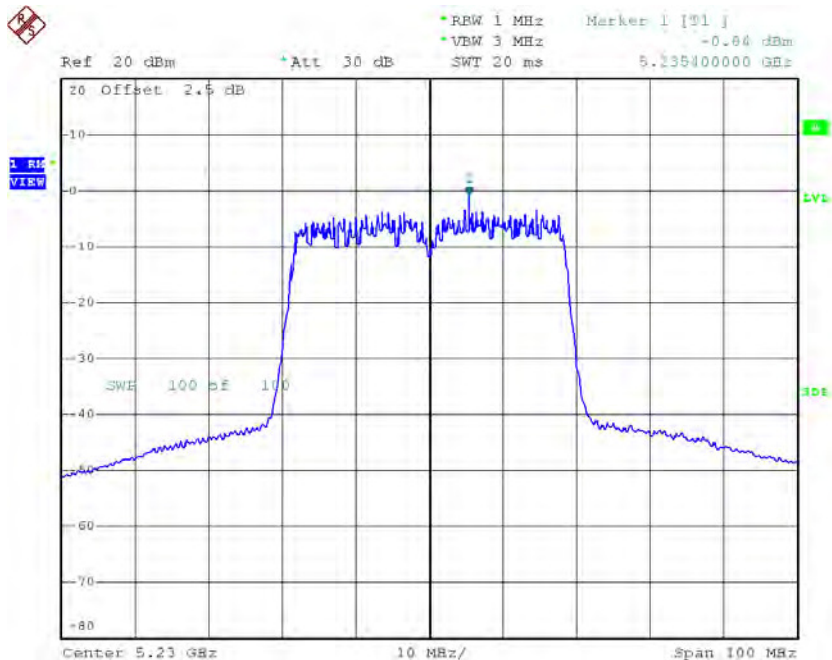

Date: 17.APR.2016 12:14:40

Test Mode: UNII-1/TX N40 Mode_CH38/CH46_Total

Channel	Frequency (MHz)	Power Density (dBm/MHz)	Limit (dBm/MHz)
CH38	5190	0.76	17.00
CH46	5230	2.77	17.00

Test Mode: UNII-3/ TX N20 Mode_CH149/CH157/CH165_ANT 1

Channel	Frequency (MHz)	Power Density (dBm/500kHz)	Duty Factor (dBm/MHz)	Power Density + Duty Factor (dBm/500kHz)	Limit (dBm/500kHz)
CH149	5745	-4.82	0.51	-4.31	30.00
CH157	5785	-6.64	0.51	-6.13	30.00
CH165	5825	-6.59	0.51	-6.08	30.00

TX CH149

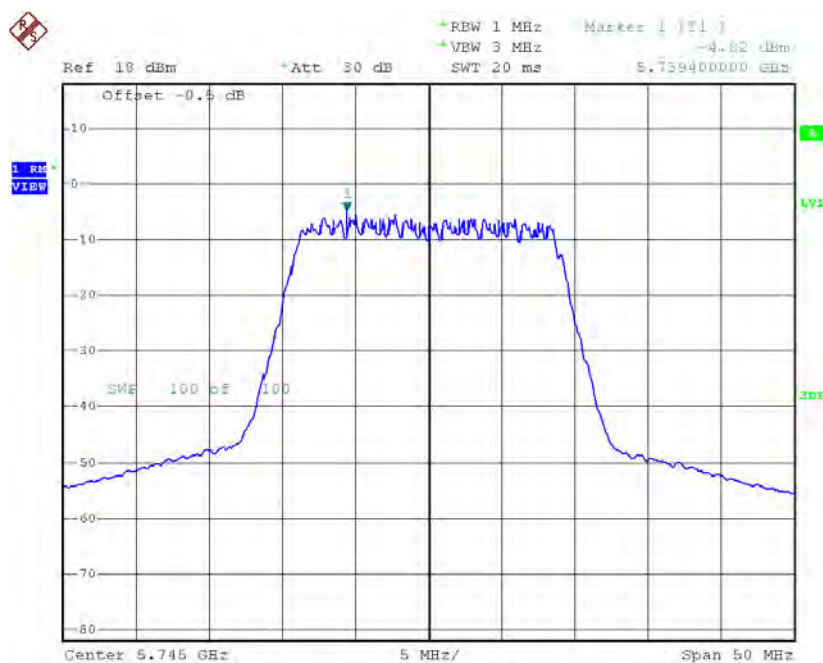

Date: 15.APR.2016 11:49:59

TX CH157

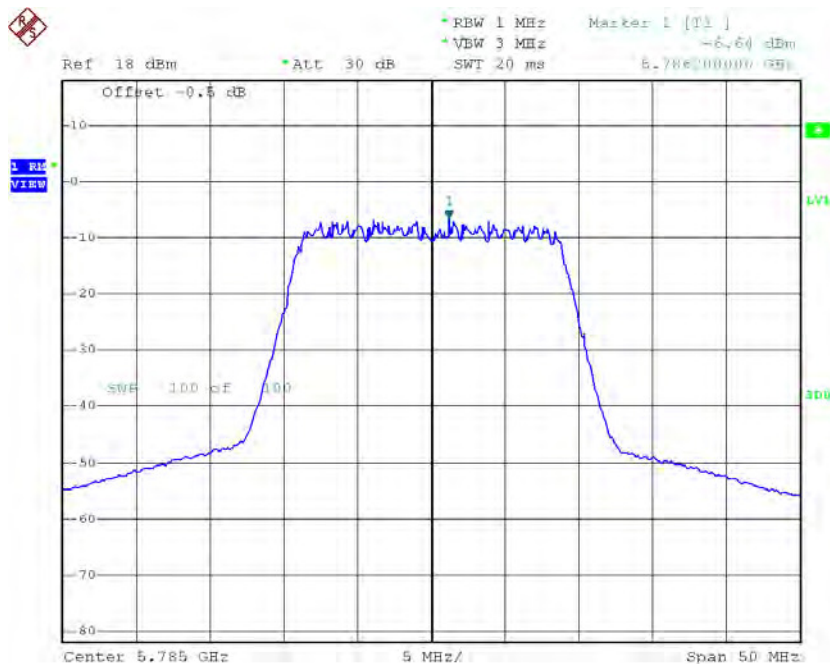

Date: 15.APR.2016 11:58:38

TX CH165

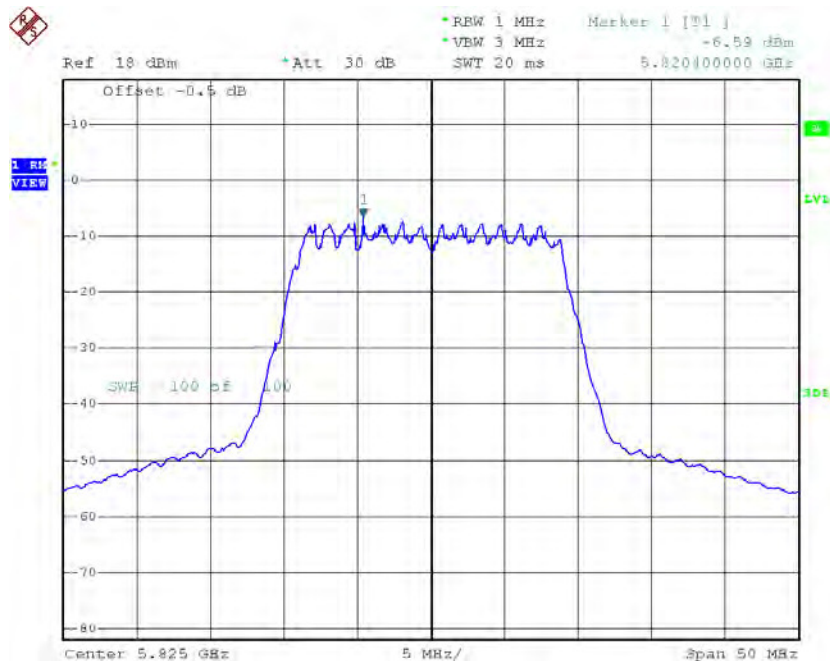

Date: 15.APR.2016 12:00:14

Test Mode: UNII-3/ TX N20 Mode_CH149/CH157/CH165_ANT 2

Channel	Frequency (MHz)	Power Density (dBm/500kHz)	Duty Factor (dBm/MHz)	Power Density + Duty Factor (dBm/500kHz)	Limit (dBm/500kHz)
CH149	5745	-2.66	0.51	-2.15	30.00
CH157	5785	-3.24	0.51	-2.73	30.00
CH165	5825	-3.76	0.51	-3.25	30.00

TX CH149

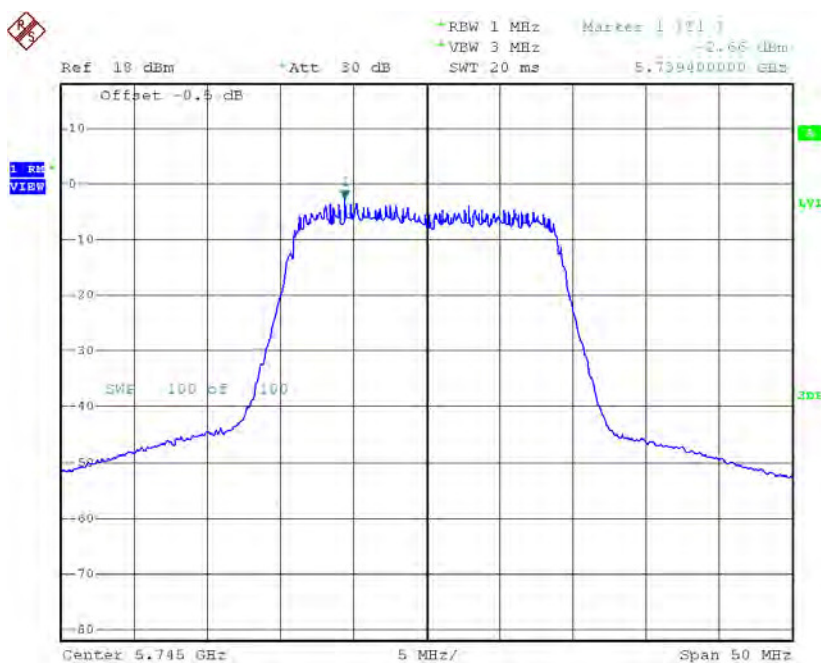

Date: 17.APR.2016 11:41:36

TX CH157

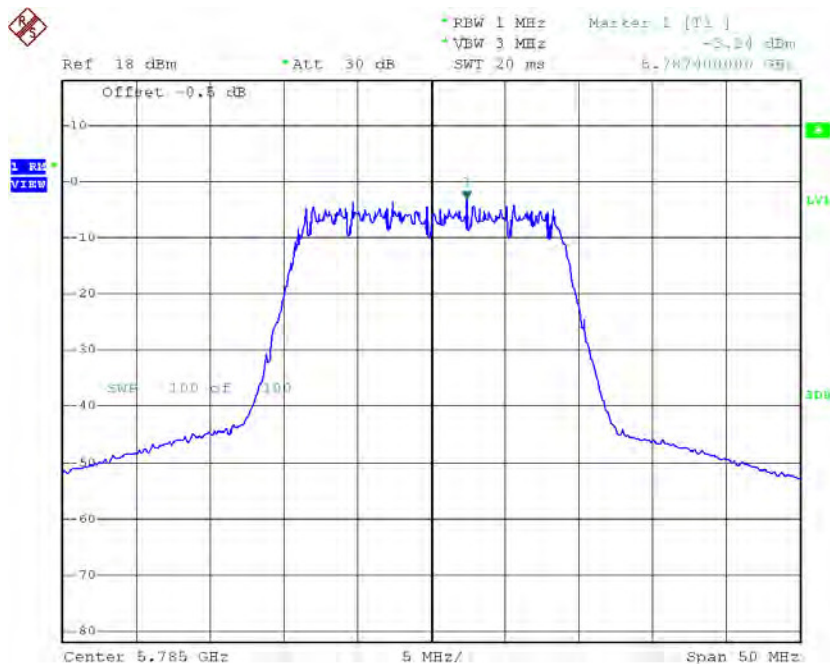

Date: 17.APR.2016 11:43:30

TX CH165

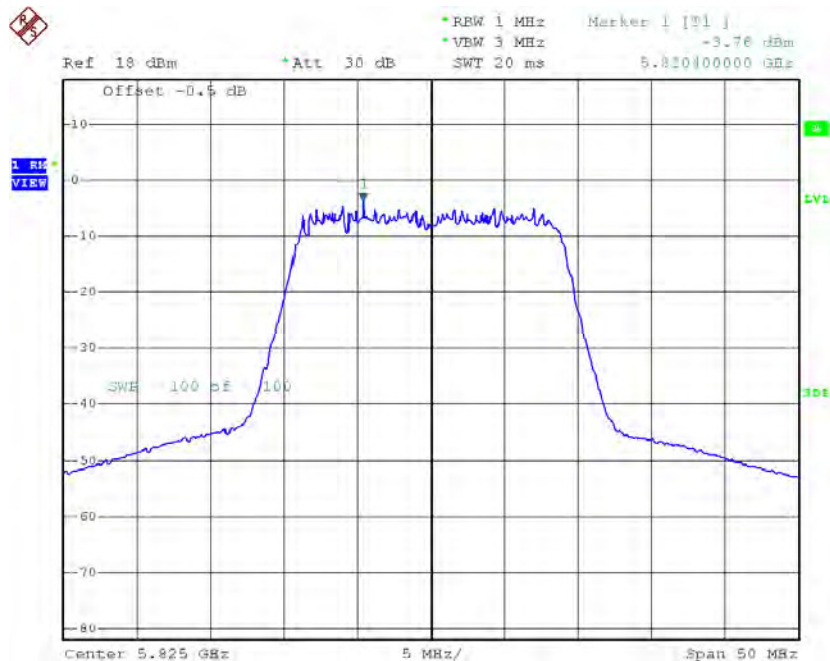

Date: 17.APR.2016 11:44:32

Test Mode: UNII-3/ TX N20 Mode_CH149/CH157/CH165_Total

Channel	Frequency (MHz)	Power Density (dBm/500kHz)	Limit (dBm/500kHz)
CH149	5745	-0.09	30.00
CH157	5785	-1.10	30.00
CH165	5825	-1.43	30.00

Test Mode: UNII-3/ TX N40 Mode_CH151/CH159_ANT 1

Channel	Frequency (MHz)	Power Density (dBm/500kHz)	Duty Factor (dBm/MHz)	Power Density + Duty Factor (dBm/500kHz)	Limit (dBm/500kHz)
CH151	5755	-5.42	1.35	-4.07	30.00
CH159	5795	-9.08	1.35	-7.73	30.00

TX CH151

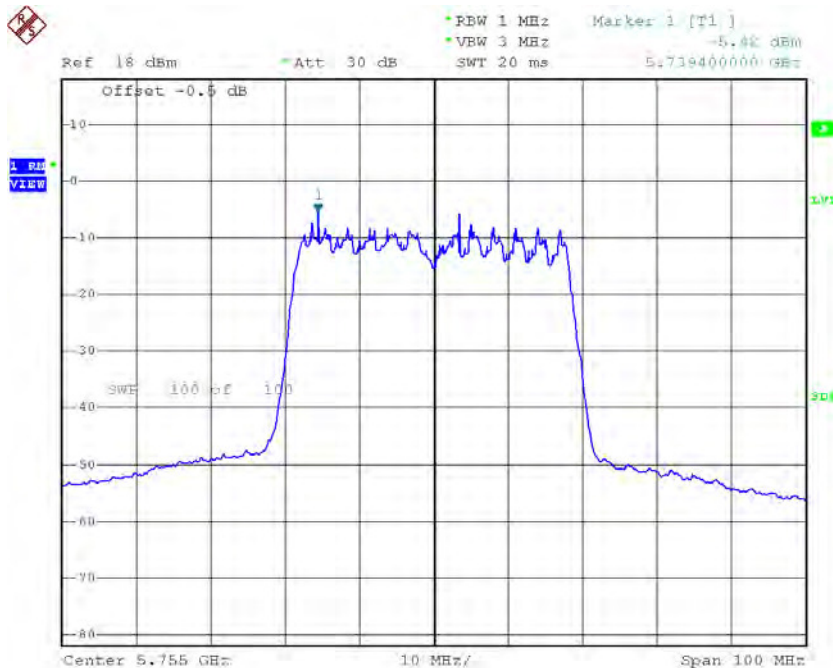

Date: 17.APR.2016 11:20:44

TX CH159

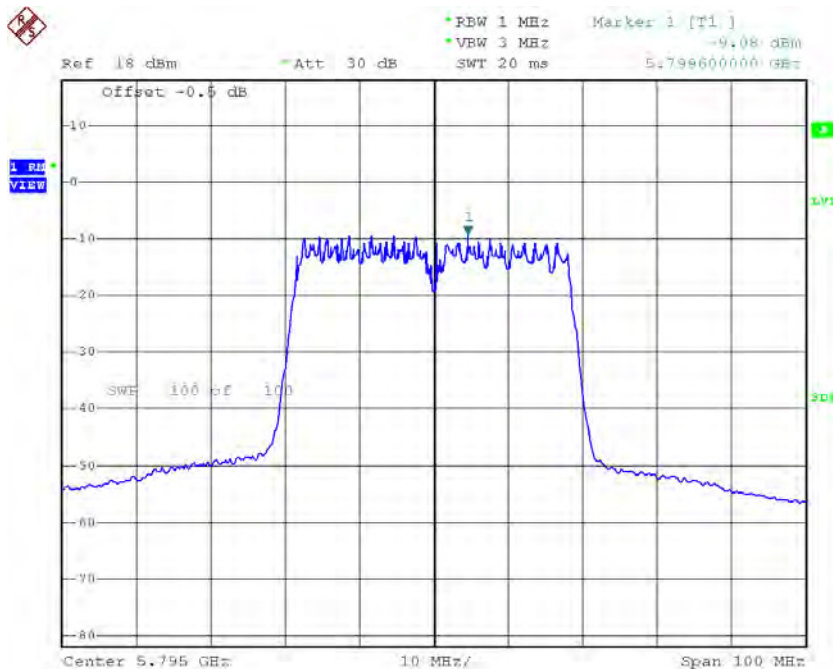

Date: 17.APR.2016 11:21:53

Test Mode: UNII-3/ TX N40 Mode_CH151/CH159_ANT 2

Channel	Frequency (MHz)	Power Density (dBm/500kHz)	Duty Factor (dBm/MHz)	Power Density + Duty Factor (dBm/500kHz)	Limit (dBm/500kHz)
CH151	5755	-4.60	1.35	-3.25	30.00
CH159	5795	-8.06	1.35	-6.71	30.00

TX CH151

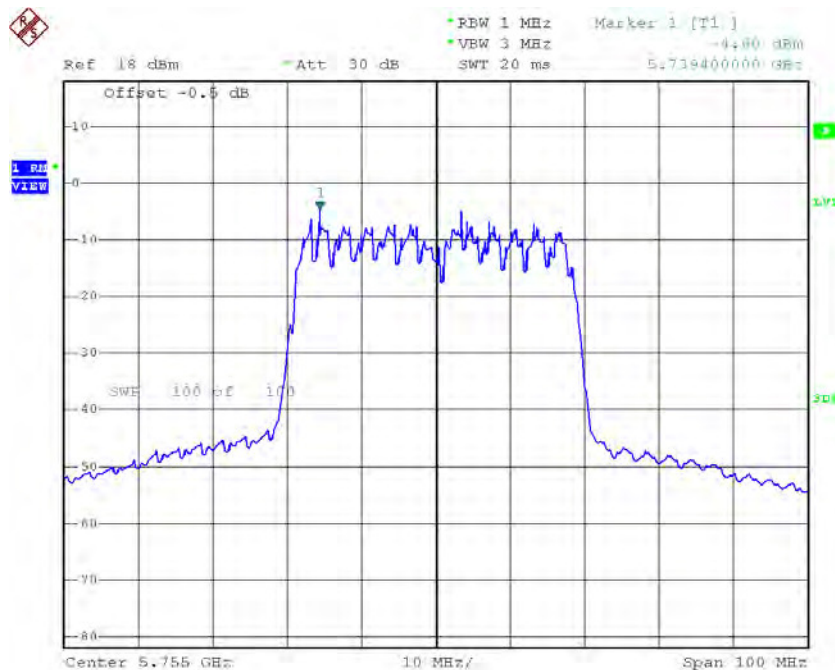

Date: 17.APR.2016 12:16:35

TX CH159

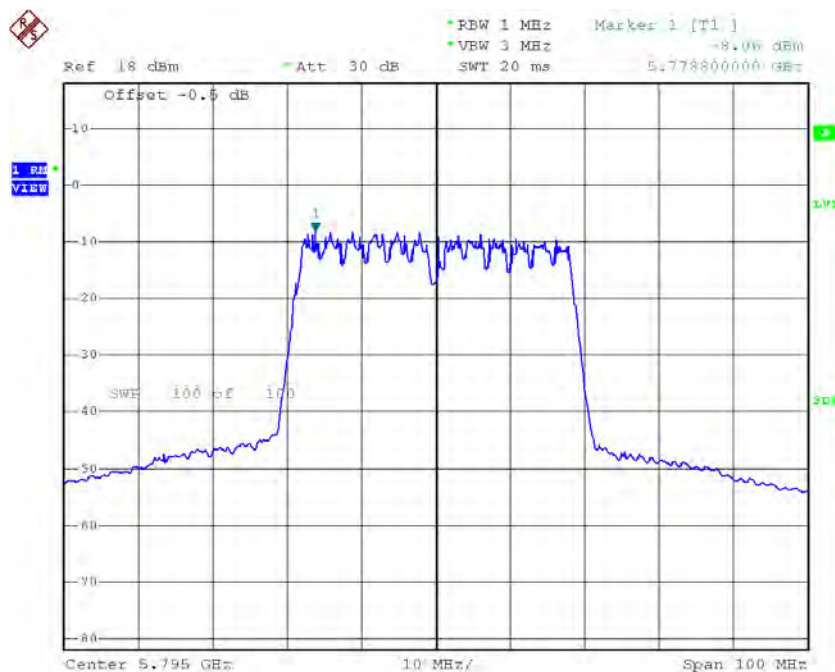

Date: 17.APR.2016 12:17:41

Test Mode: UNII-3/ TX N40 Mode_CH151/CH159_Total

Channel	Frequency (MHz)	Power Density (dBm/500kHz)	Limit (dBm/500kHz)
CH151	5755	-0.63	30.00
CH159	5795	-4.18	30.00

Test Mode: UNII-1/TX AC (VHT20MHz) Mode_CH36/CH40/CH48_ANT 1

Channel	Frequency (MHz)	Power Density (dBm/MHz)	Duty Factor (dBm/MHz)	Power Density + Duty Factor (dBm/MHz)	Limit (dBm/MHz)
CH36	5180	1.01	0.22	1.23	17.00
CH40	5200	1.00	0.22	1.22	17.00
CH48	5240	1.17	0.22	1.39	17.00

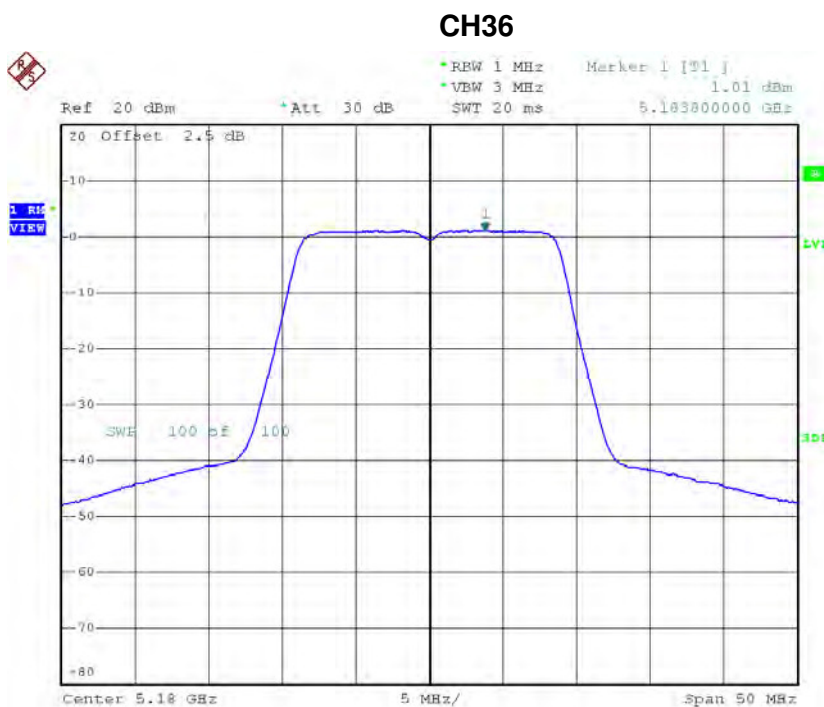

Date: 17.APR.2016 10:56:45

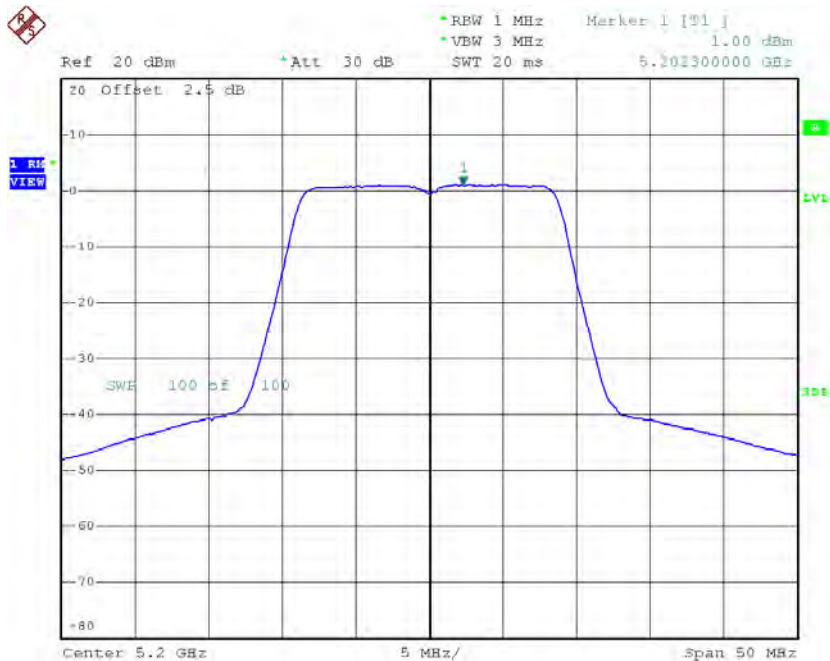
CH40

Date: 17.APR.2016 10:57:43

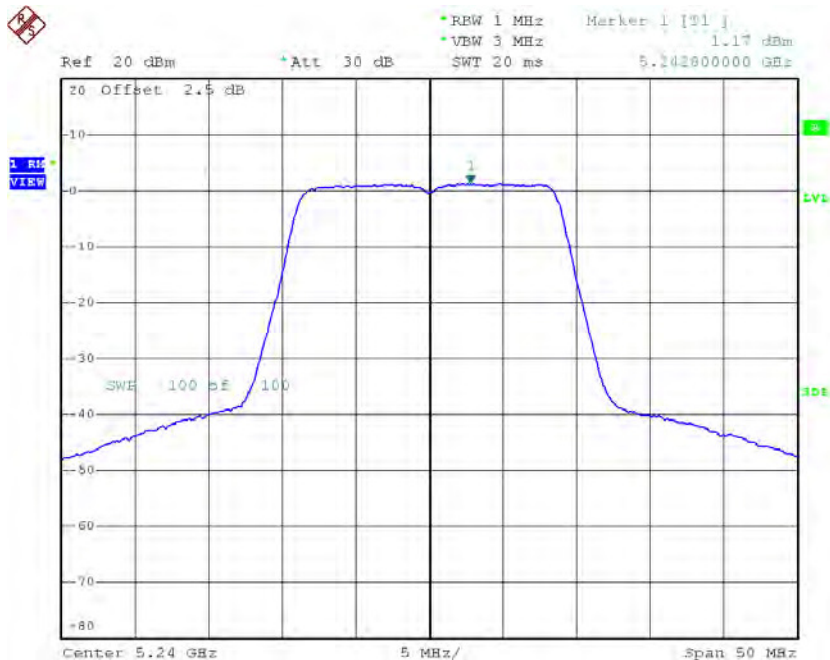
CH48

Date: 17.APR.2016 10:59:19

Test Mode: UNII-1/TX AC (VHT20MHz) Mode_CH36/CH40/CH48_ANT 2

Channel	Frequency (MHz)	Power Density (dBm/MHz)	Duty Factor (dBm/MHz)	Power Density + Duty Factor (dBm/MHz)	Limit (dBm/MHz)
CH36	5180	1.39	0.22	1.61	17.00
CH40	5200	1.82	0.22	2.04	17.00
CH48	5240	3.00	0.22	3.22	17.00

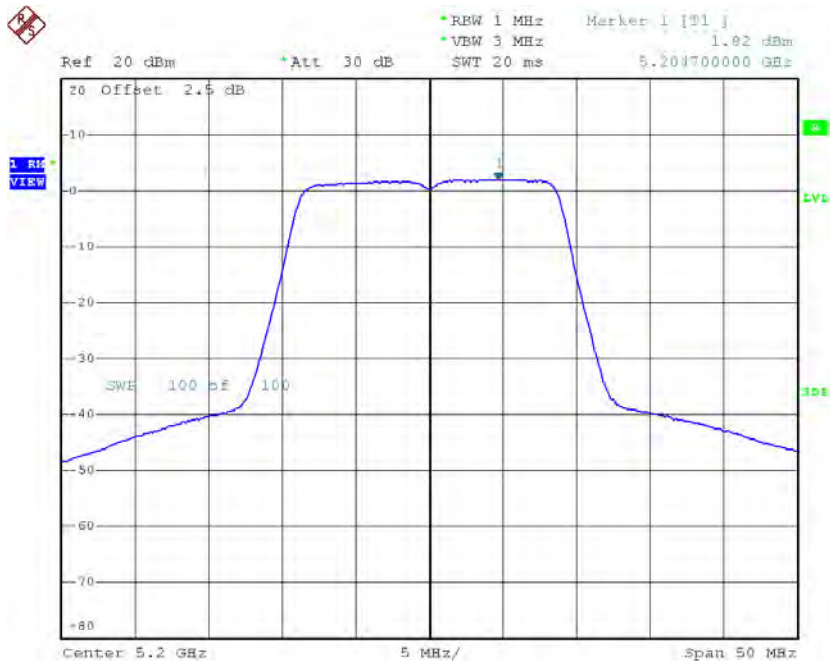

Date: 17.APR.2016 11:45:52

CH40

Date: 17.APR.2016 11:47:55

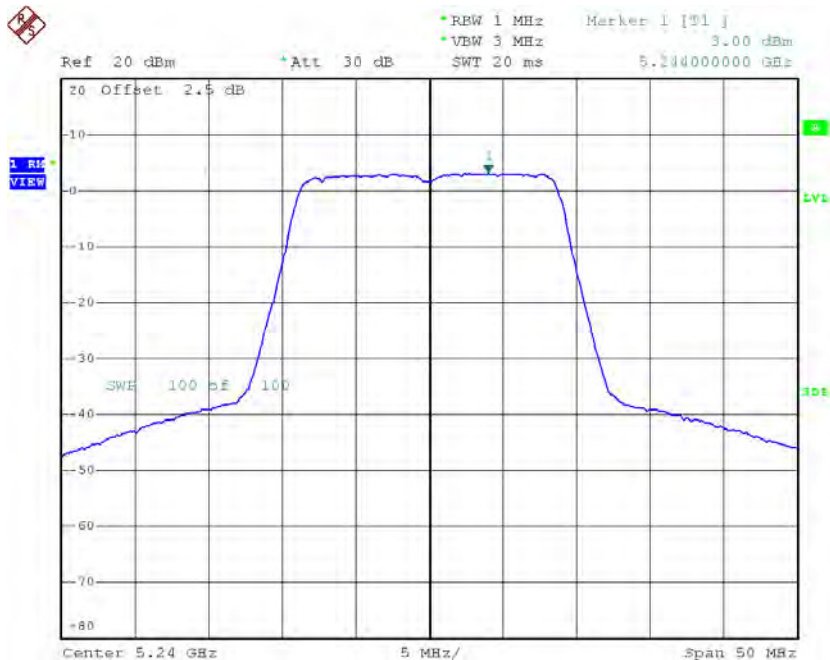
CH48

Date: 17.APR.2016 11:49:20

Test Mode: UNII-1/TX AC (VHT20MHz) Mode_CH36/CH40/CH48_Total

Channel	Frequency (MHz)	Power Density (dBm/MHz)	Limit (dBm/MHz)
CH36	5180	4.43	17.00
CH40	5200	4.66	17.00
CH48	5240	5.41	17.00

Test Mode: UNII-1/TX AC (VHT40MHz) Mode_CH38/CH46_ANT 1

Channel	Frequency (MHz)	Power Density (dBm/MHz)	Duty Factor (dBm/MHz)	Power Density + Duty Factor (dBm/MHz)	Limit (dBm/MHz)
CH38	5190	-0.59	0.89	0.30	17.00
CH46	5230	0.89	0.89	1.78	17.00

CH38

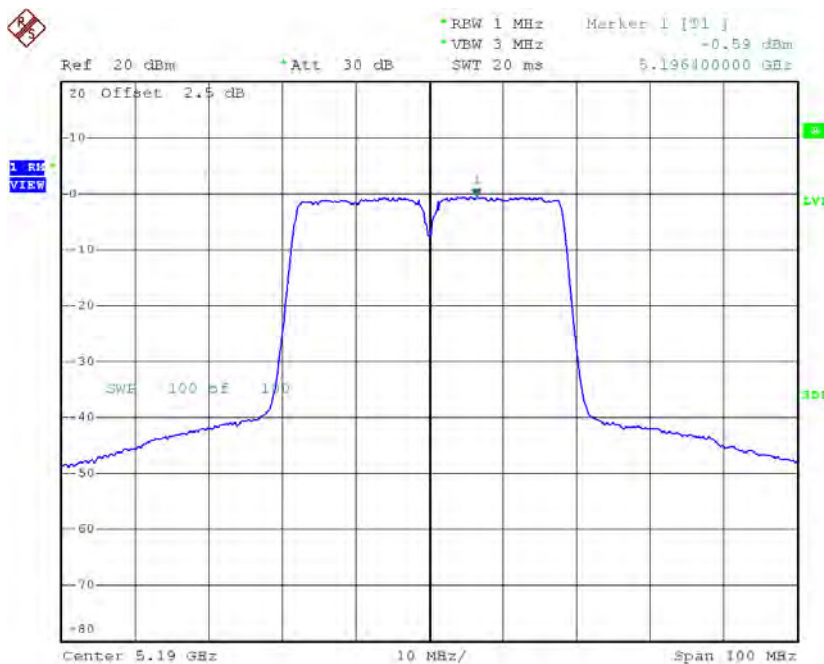

Date: 17.APR.2016 11:23:12

CH46

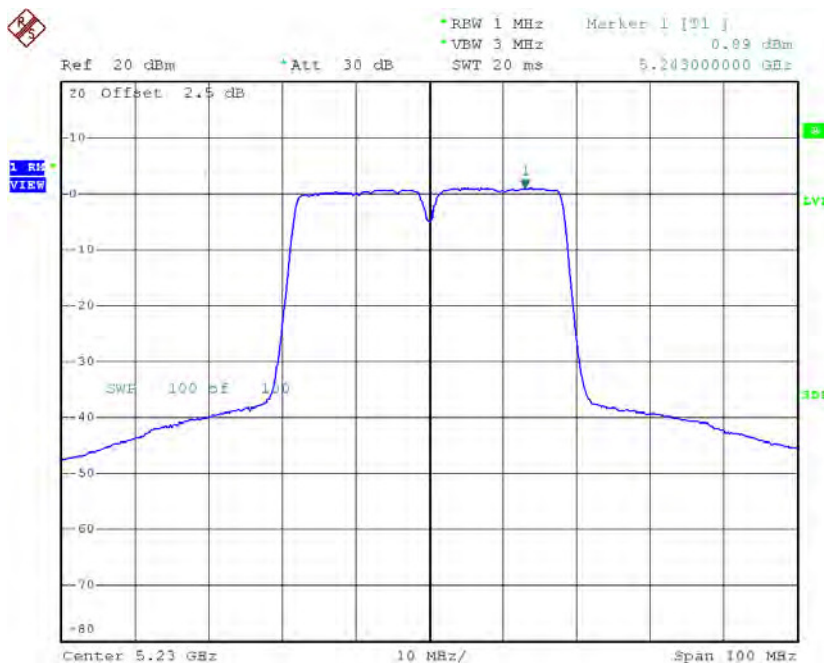

Date: 17.APR.2016 11:24:24

Test Mode: UNII-1/TX AC (VHT40MHz) Mode_CH38/CH46_ANT 2

Channel	Frequency (MHz)	Power Density (dBm/MHz)	Duty Factor (dBm/MHz)	Power Density + Duty Factor (dBm/MHz)	Limit (dBm/MHz)
CH38	5190	0.14	0.89	1.03	17.00
CH46	5230	2.42	0.89	3.31	17.00

CH38

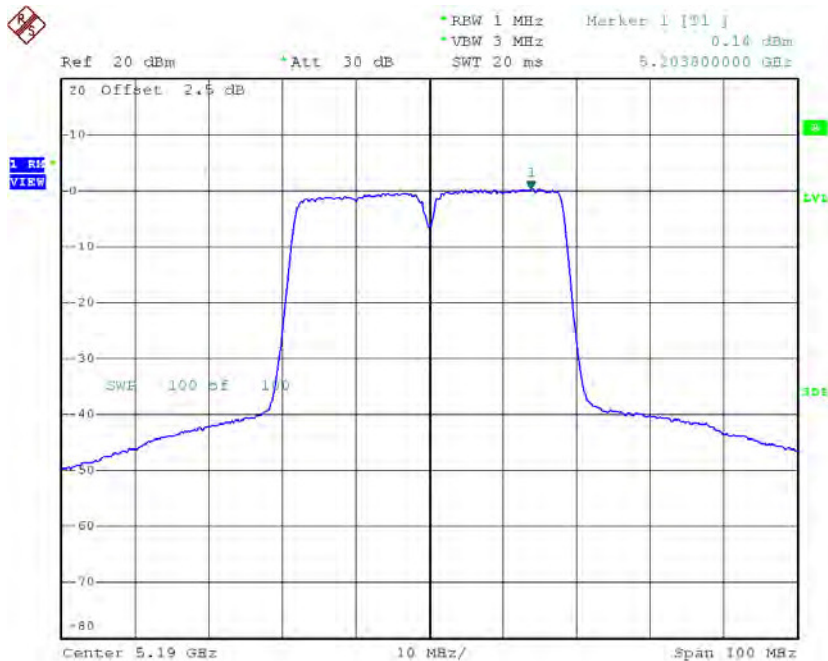

Date: 17.APR.2016 12:18:58

CH46

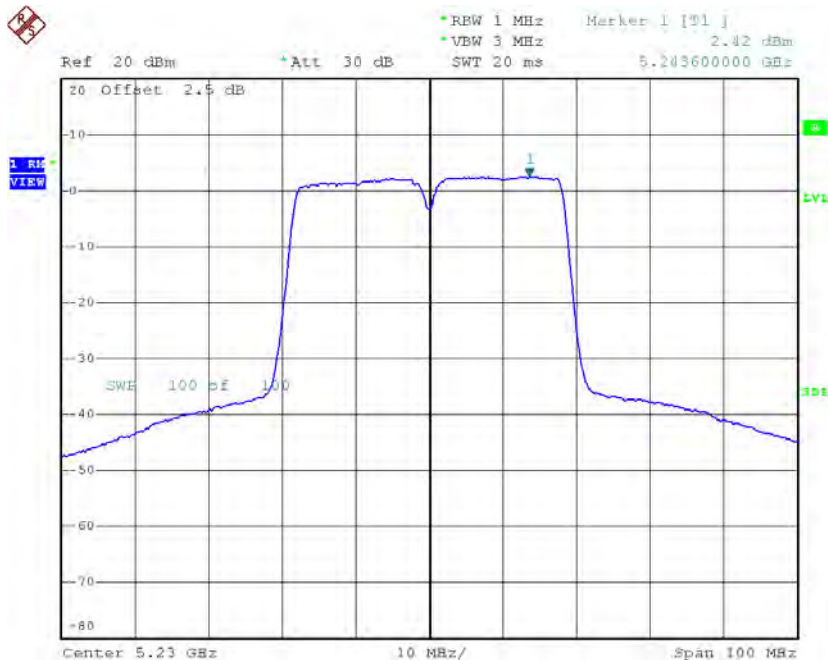

Date: 17.APR.2016 14:11:51

Test Mode: UNII-1/TX AC (VHT40MHz) Mode_CH38/CH46_Total

Channel	Frequency (MHz)	Power Density (dBm/MHz)	Limit (dBm/MHz)
CH38	5190	3.69	17.00
CH46	5230	5.62	17.00

Test Mode: UNII-1/TX AC(VHT80) Mode_CH42_ANT 1

Channel	Frequency (MHz)	Power Density (dBm/MHz)	Duty Factor (dBm/MHz)	Power Density + Duty Factor (dBm/MHz)	Limit (dBm/MHz)
CH42	5210	-4.80	1.05	-3.75	17.00

CH42

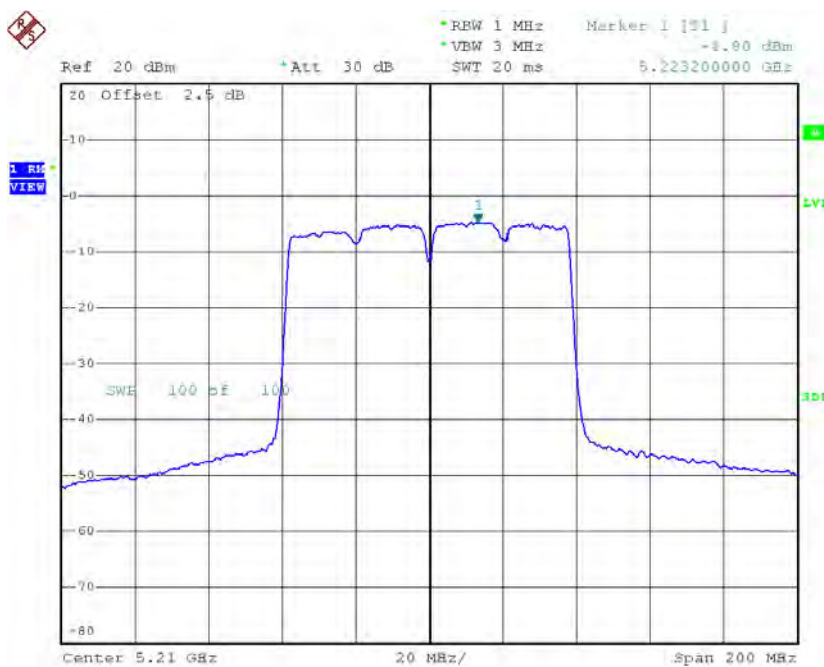

Date: 17.APR.2016 11:32:54

Test Mode: UNII-1/TX AC(VHT80) Mode_CH42_ANT 2

Channel	Frequency (MHz)	Power Density (dBm/MHz)	Duty Factor (dBm/MHz)	Power Density + Duty Factor (dBm/MHz)	Limit (dBm/MHz)
CH42	5210	-5.88	1.05	-4.83	17.00

CH42

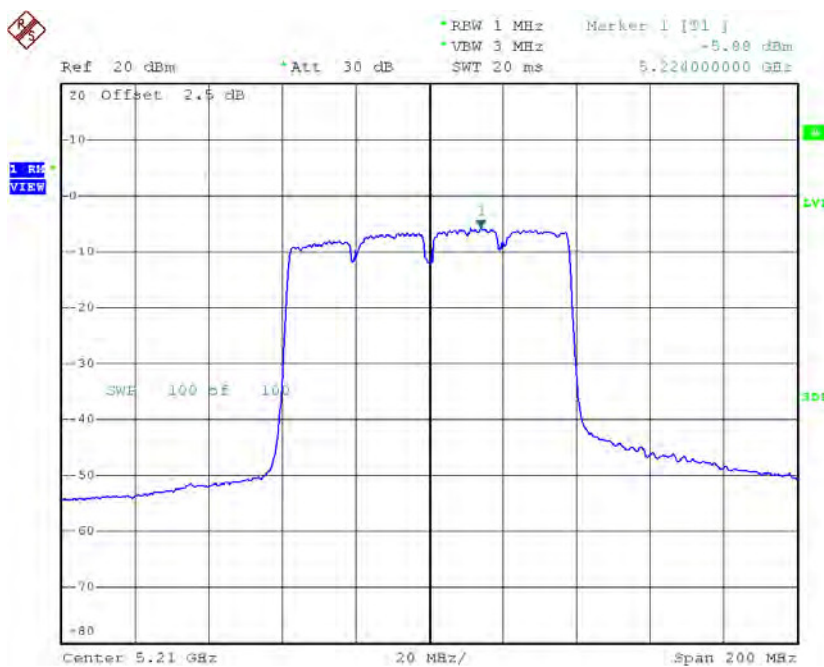

Date: 17.APR.2016 14:34:23

Test Mode: UNII-1/TX AC(VHT80) Mode_CH42_Total

Channel	Frequency (MHz)	Power Density (dBm/MHz)	Limit (dBm/MHz)
CH42	5210	-1.25	17.00

Test Mode: UNII-3/ TX AC (VHT20MHz) Mode_CH149/CH157/CH165_ANT 1

Channel	Frequency (MHz)	Power Density (dBm/500kHz)	Duty Factor (dBm/MHz)	Power Density + Duty Factor (dBm/500kHz)	Limit (dBm/500kHz)
CH149	5745	-4.59	0.22	-4.37	30.00
CH157	5785	-5.36	0.22	-5.14	30.00
CH165	5825	-6.38	0.22	-6.16	30.00

TX CH149

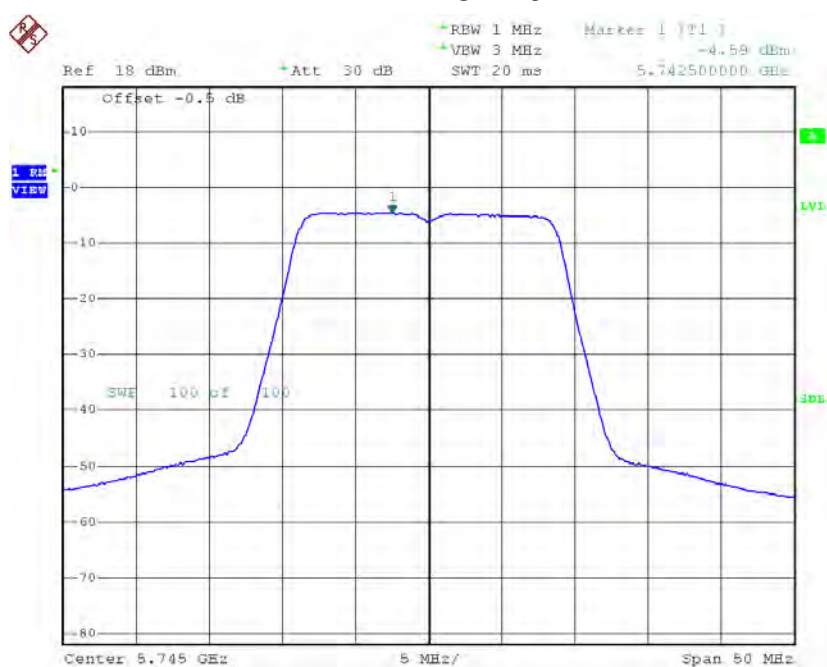

Date: 17.APR.2016 11:03:21

TX CH157

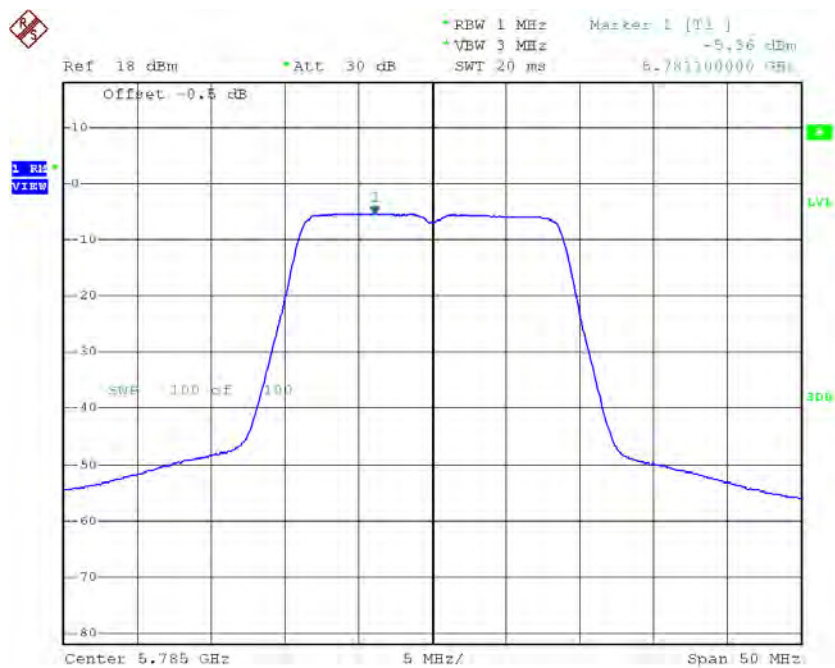

Date: 17.APR.2016 11:10:40

TX CH165

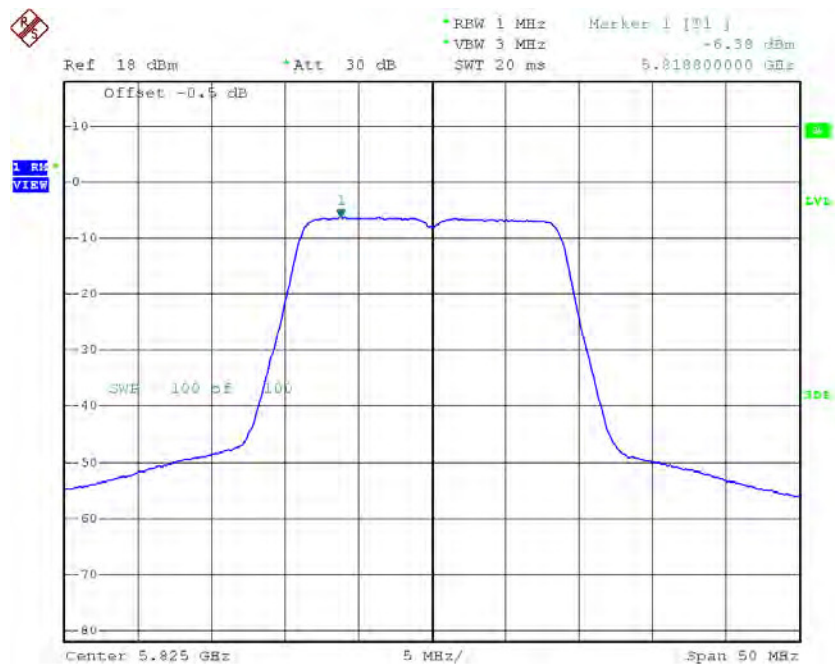

Date: 17.APR.2016 11:11:46

Test Mode: UNII-3/ TX AC (VHT20MHz) Mode_CH149/CH157/CH165_ANT 2

Channel	Frequency (MHz)	Power Density (dBm/500kHz)	Duty Factor (dBm/MHz)	Power Density + Duty Factor (dBm/500kHz)	Limit (dBm/500kHz)
CH149	5745	-2.63	0.22	-2.41	30.00
CH157	5785	-3.31	0.22	-3.09	30.00
CH165	5825	-3.74	0.22	-3.52	30.00

TX CH149

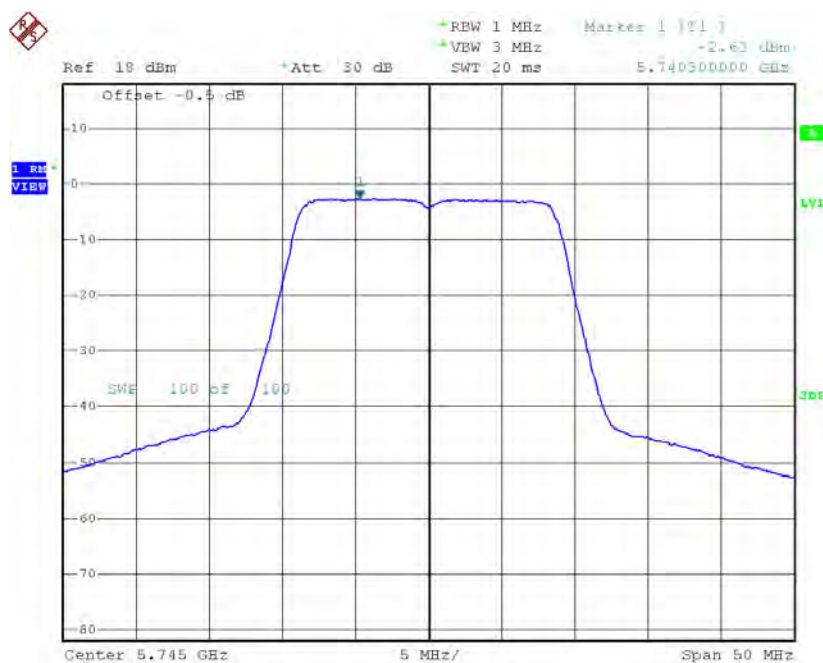

Date: 17.APR.2016 11:59:23

TX CH157

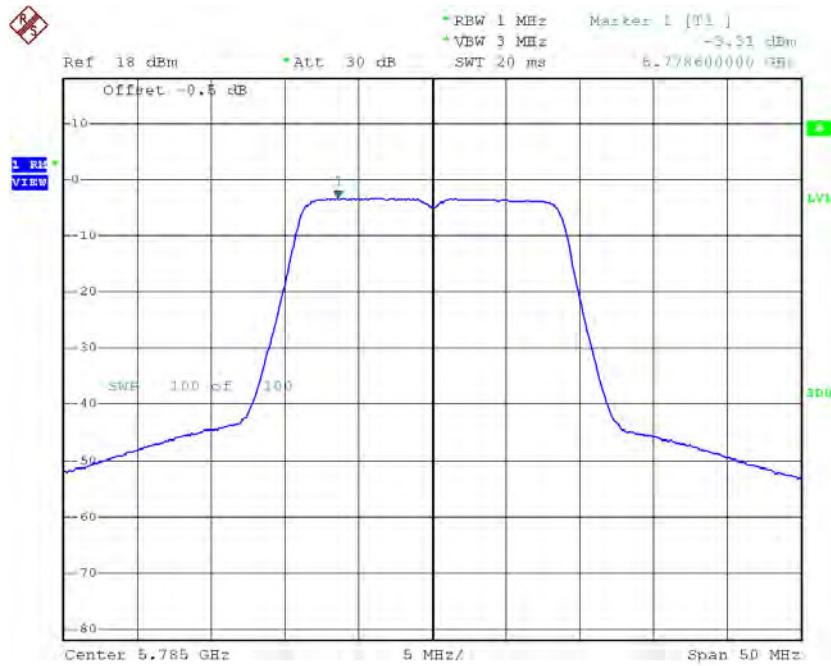

Date: 17.APR.2016 12:03:56

TX CH165

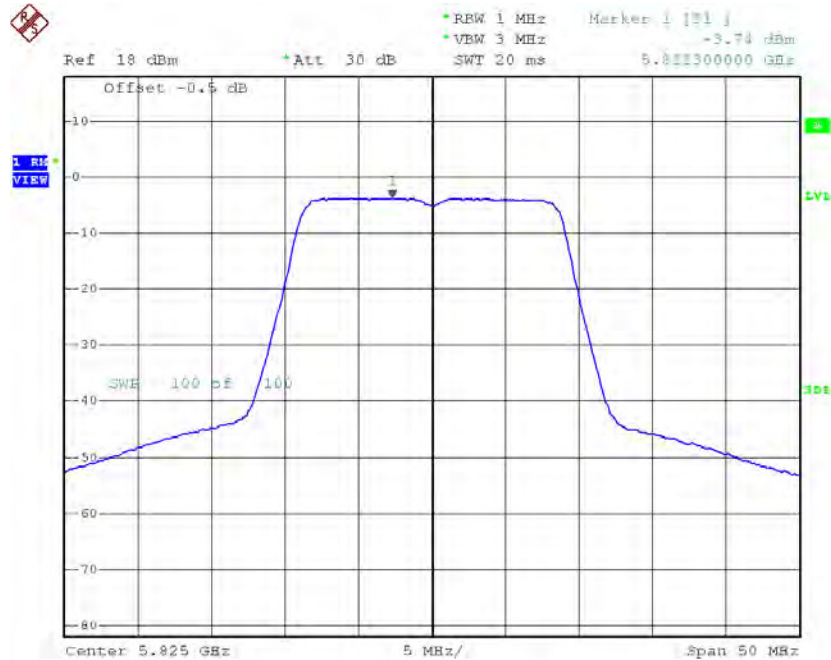

Date: 17.APR.2016 12:09:29

Test Mode: UNII-3/ TX AC (VHT20MHz) Mode_CH149/CH157/CH165_Total

Channel	Frequency (MHz)	Power Density (dBm/500kHz)	Limit (dBm/500kHz)
CH149	5745	-0.27	30.00
CH157	5785	-0.98	30.00
CH165	5825	-1.63	30.00

Test Mode: UNII-3/ TX AC (VHT40MHz) Mode_CH151/CH159_ANT 1

Channel	Frequency (MHz)	Power Density (dBm/500kHz)	Duty Factor (dBm/MHz)	Power Density + Duty Factor (dBm/500kHz)	Limit (dBm/500kHz)
CH151	5755	-4.85	0.89	-3.96	30.00
CH159	5795	-5.40	0.89	-4.51	30.00

TX CH151

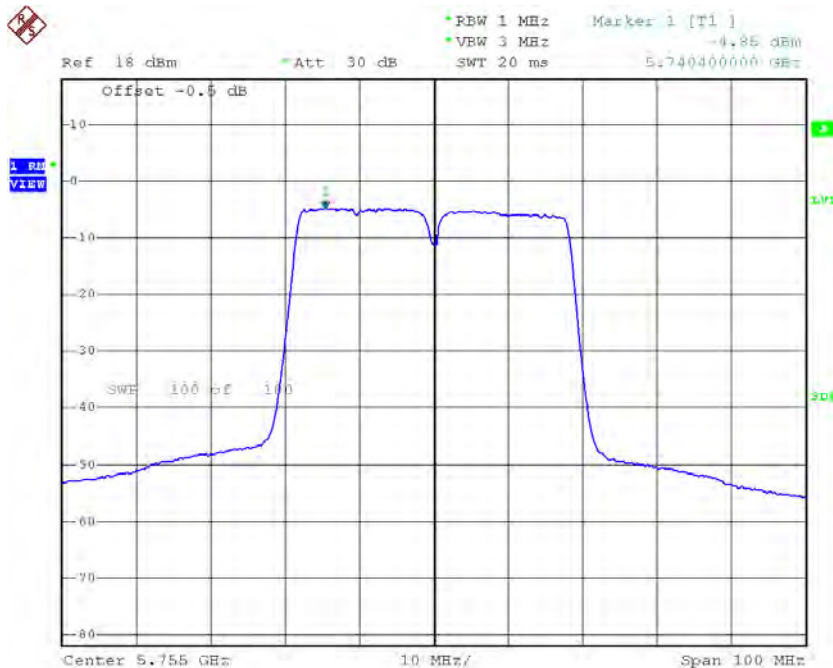

Date: 17.APR.2016 11:25:30

TX CH159

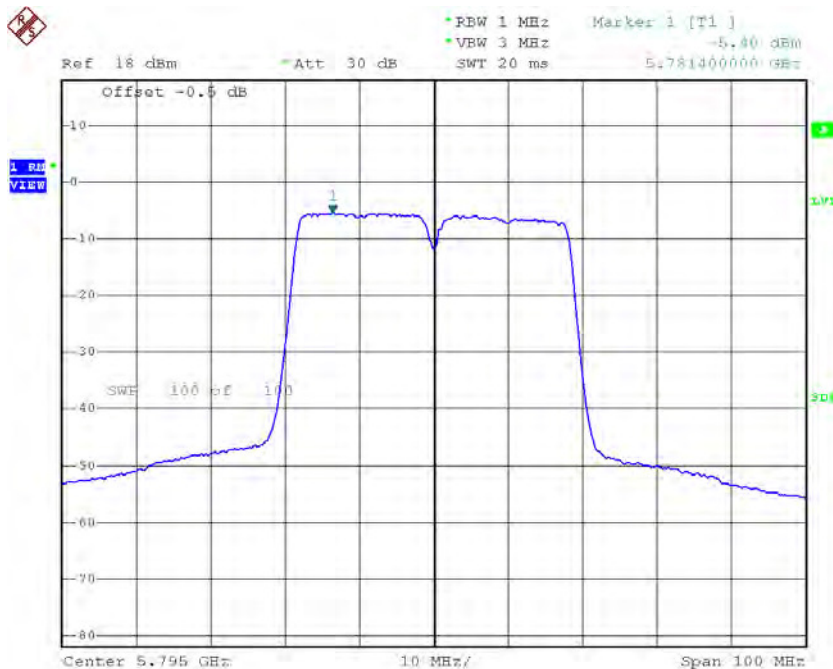

Date: 17.APR.2016 11:28:06

Test Mode: UNII-3/ TX AC (VHT40MHz) Mode_CH151/CH159_ANT 2

Channel	Frequency (MHz)	Power Density (dBm/500kHz)	Duty Factor (dBm/MHz)	Power Density + Duty Factor (dBm/500kHz)	Limit (dBm/500kHz)
CH151	5755	-4.11	0.89	-3.22	30.00
CH159	5795	-4.35	0.89	-3.46	30.00

TX CH151

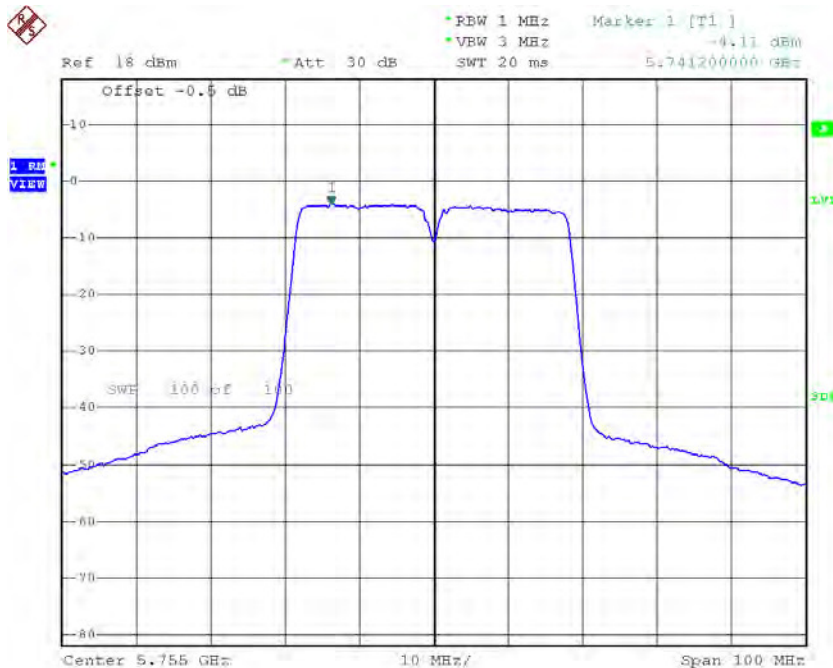

Date: 17.APR.2016 14:13:07

TX CH159

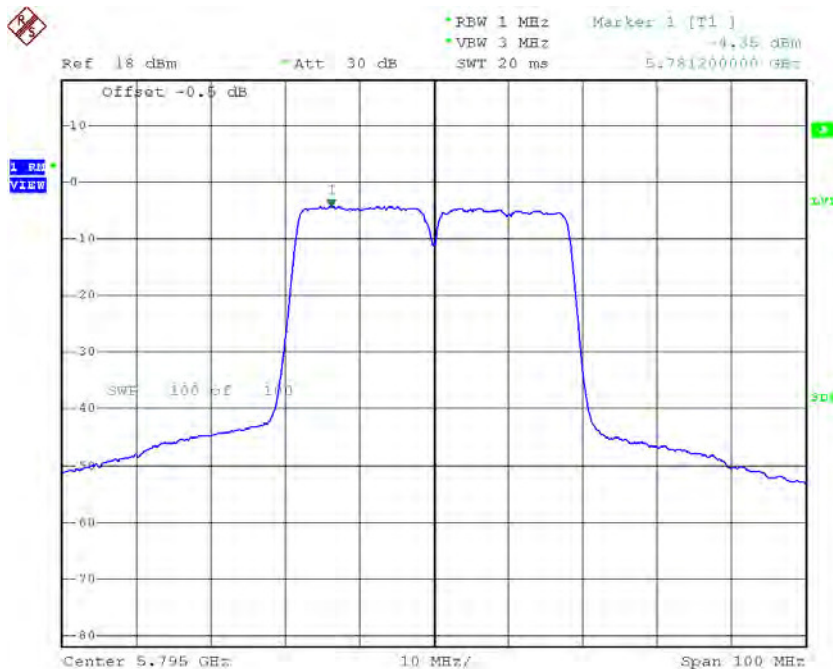

Date: 17.APR.2016 14:14:19

Test Mode: UNII-3/ TX AC (VHT40MHz) Mode_CH151/CH159_Total

Channel	Frequency (MHz)	Power Density (dBm/500kHz)	Limit (dBm/500kHz)
CH151	5755	-0.56	30.00
CH159	5795	-0.94	30.00

Test Mode: UNII-3/ TX AC(VHT80) Mode_CH155_ANT 1

Channel	Frequency (MHz)	Power Density (dBm/500kHz)	Duty Factor (dBm/MHz)	Power Density + Duty Factor (dBm/500kHz)	Limit (dBm/500kHz)
CH155	5775	-6.21	1.05	-5.16	30.00

TX CH155

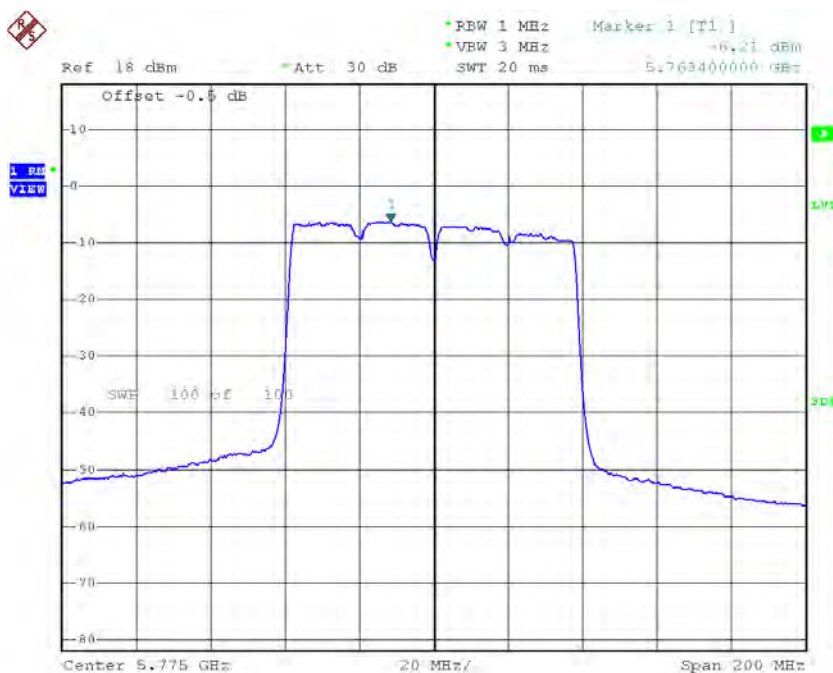

Date: 17.APR.2016 11:34:38

Test Mode: UNII-3/ TX AC(VHT80) Mode_CH155_ANT 2

Channel	Frequency (MHz)	Power Density (dBm/500kHz)	Duty Factor (dBm/MHz)	Power Density + Duty Factor (dBm/500kHz)	Limit (dBm/500kHz)
CH155	5775	-5.72	1.05	-4.67	30.00

TX CH155

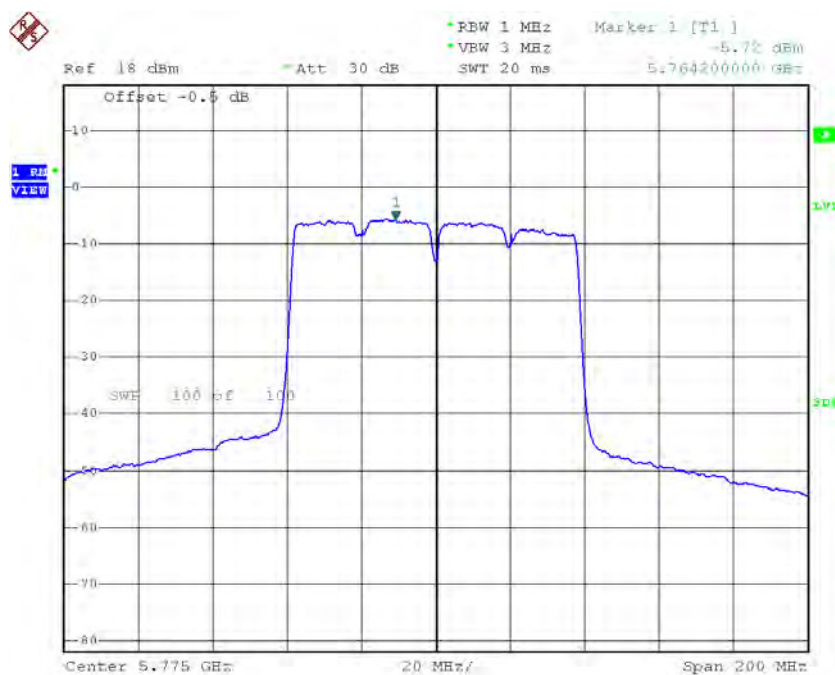

Date: 17.APR.2016 14:35:43

Test Mode: UNII-3/ TX AC(VHT80) Mode_CH155_Total

Channel	Frequency (MHz)	Power Density (dBm/500kHz)	Limit (dBm/500kHz)
CH155	5775	-1.90	30.00

ATTACHMENT H - FREQUENCY STABILITY

Test Mode:	UNII-1
-------------------	---------------

Voltage vs. Frequency Stability

Voltage	Measurement Frequency (MHz)
(V)	5180.0000
132	5179.9784
120	5179.9792
108	5179.9792
Max. Deviation (MHz)	0.0216
Max. Deviation (ppm)	4.1699

Temperature vs. Frequency Stability

Temperature	Measurement Frequency (MHz)
(°C)	5180.0000
0	5179.9792
5	5179.9796
15	5179.9796
25	5179.9792
35	5179.9800
40	5179.9796
Max. Deviation (MHz)	0.0208
Max. Deviation (ppm)	4.0154

Test Mode:	UNII-3
-------------------	---------------

Voltage vs. Frequency Stability

Voltage	Measurement Frequency (MHz)
(V)	5745.0000
132	5744.9760
120	5744.9760
108	5744.9764
Max. Deviation (MHz)	0.0240
Max. Deviation (ppm)	4.1775

Temperature vs. Frequency Stability

Temperature	Measurement Frequency (MHz)
(°C)	5745.0000
0	5744.9772
5	5744.9776
15	5744.9784
25	5744.9784
35	5744.9784
40	5744.9788
Max. Deviation (MHz)	0.0228
Max. Deviation (ppm)	3.9687