

This trace shall be routed from C67 to SWREG_SENSE&SWREG_VFB

TENDA			
Title: A5 - BCM5356C0			
Size: B	Document Number: 02 - 3.3V/1.2V POWER	Rev: 0.1	
Date: Friday, July 01, 2011	Sheet: 2	of 40	

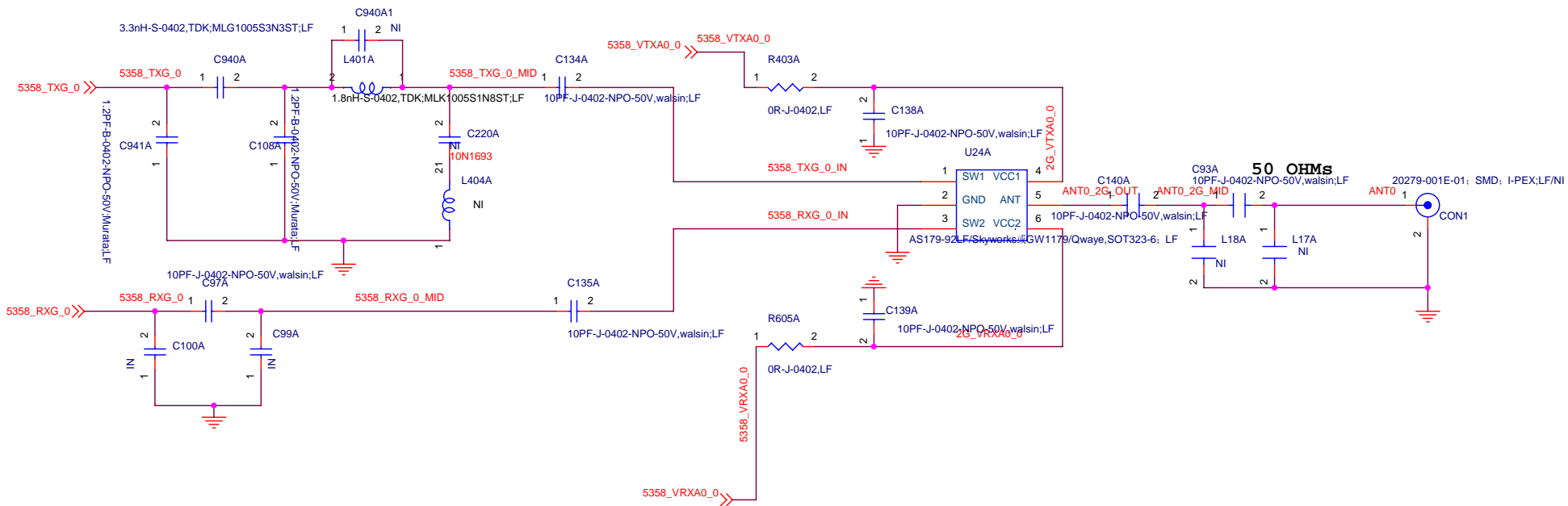

TENDA		
File: A5 - BCM5356C0		
Size: B	Document Number: 03 Front End	Rev: 0.1
Date: Thursday, June 30, 2011	Sheet: 2	of 10

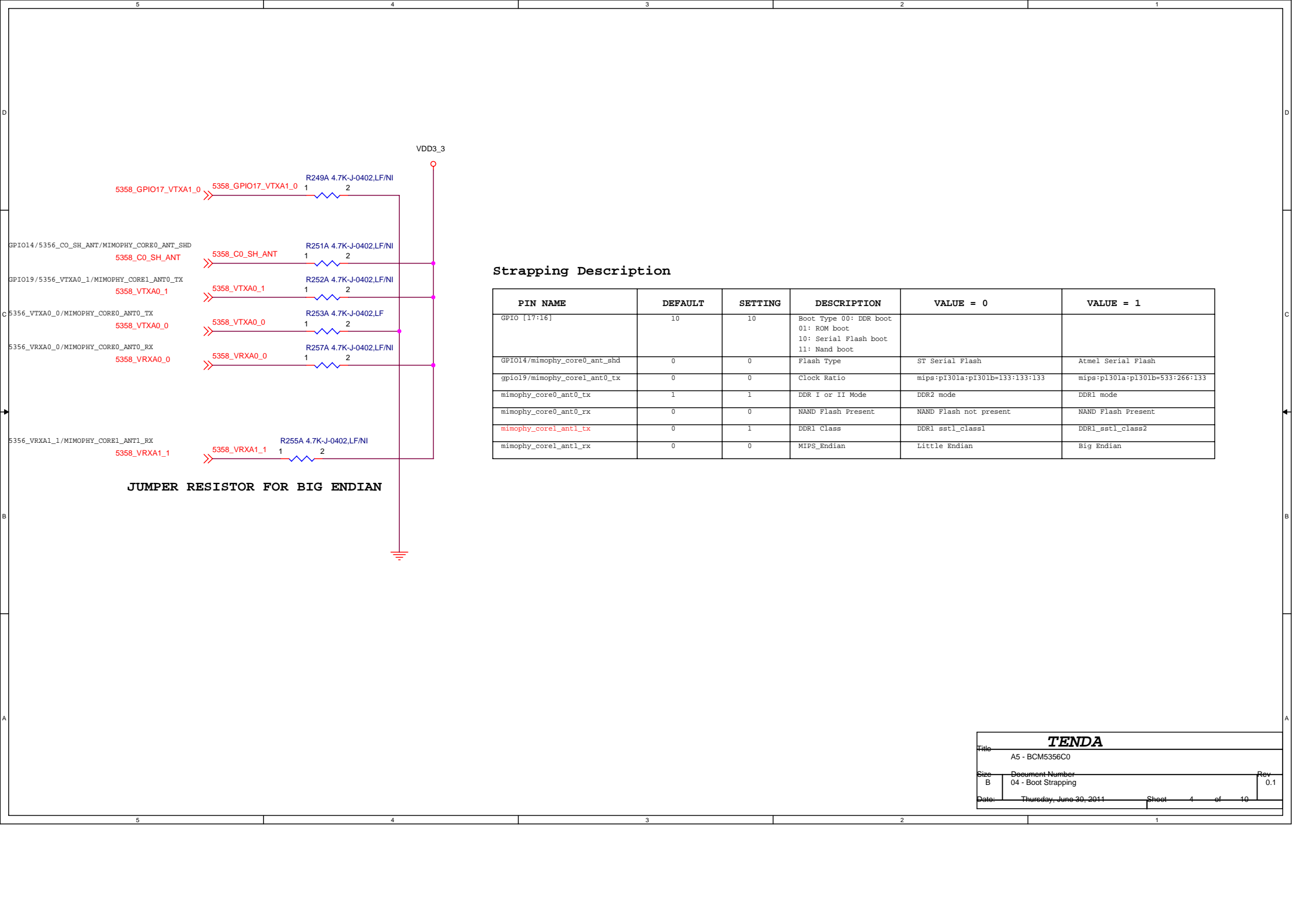

Strapping Description

PIN NAME	DEFAULT	SETTING	DESCRIPTION	VALUE = 0	VALUE = 1
GPIO [17:16]	10	10	Boot Type 00: DDR boot 01: ROM boot 10: Serial Flash boot 11: Nand boot		
GPIO14/mimophy_core0_ant_shd	0	0	Flash Type	ST Serial Flash	Atmel Serial Flash
gpio19/mimophy_core1_ant0_tx	0	0	Clock Ratio	mips:pi301a:pi301b=133:133:133	mips:pi301a:pi301b=533:266:133
mimophy_core0_ant0_tx	1	1	DDR I or II Mode	DDR2 mode	DDR1 mode
mimophy_core0_ant0_rx	0	0	NAND Flash Present	NAND Flash not present	NAND Flash Present
mimophy_core1_ant1_tx	0	1	DDR1 Class	DDR1 sst1_class1	DDR1_sst1_class2
mimophy_core1_ant1_rx	0	0	MIPS_Endian	Little Endian	Big Endian

JUMPER RESISTOR FOR BIG ENDIAN

TENDA		
Title: A5 - BCM5356C0		
Size: B	Document Number: 04 - Boot Strapping	Rev: 0.1
Date: Thursday, June 30, 2011	Sheet: 4	of 10

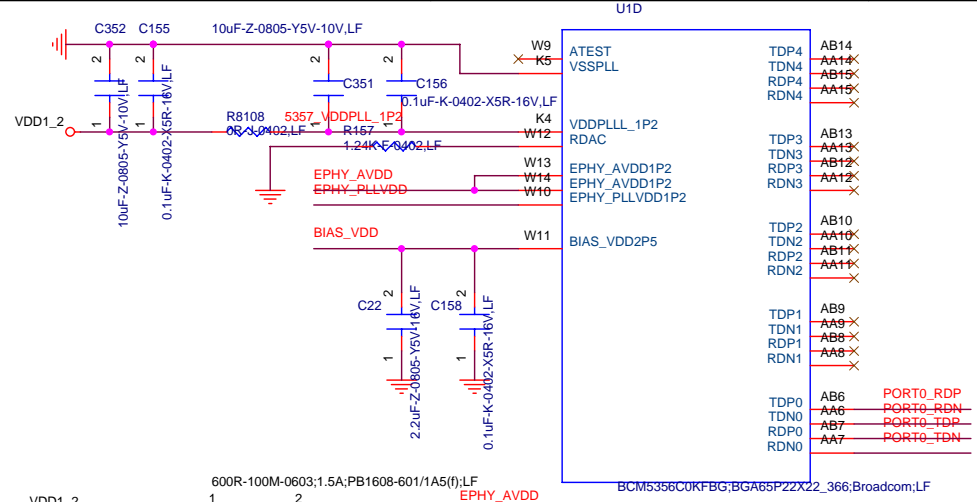

as short as possible

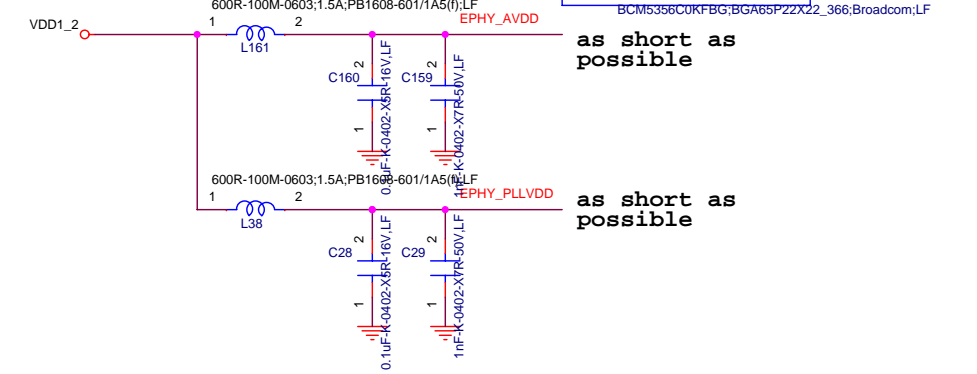

as short as possible

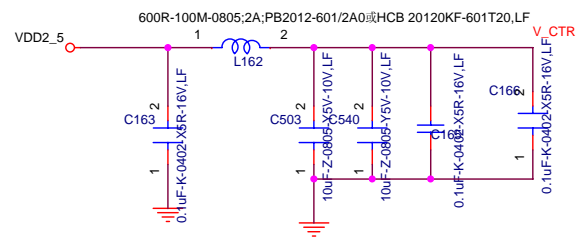

Close to Transformer

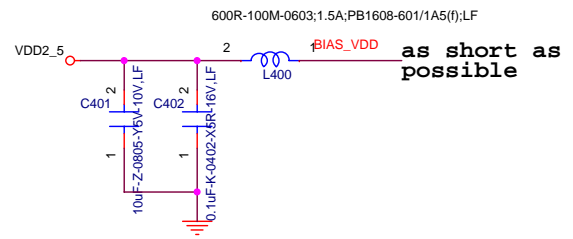

as short as possible

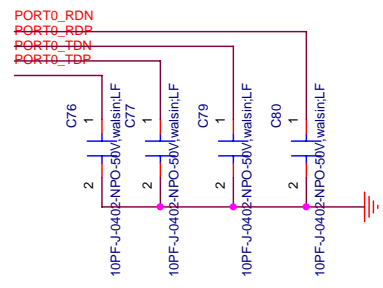
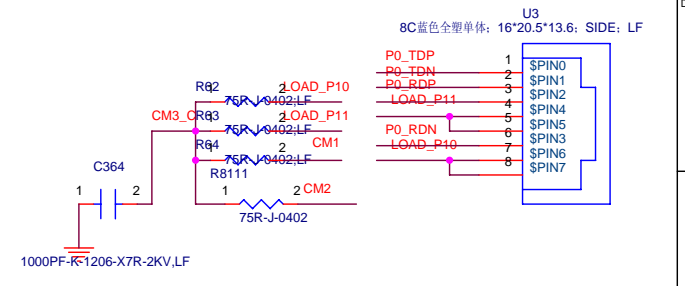
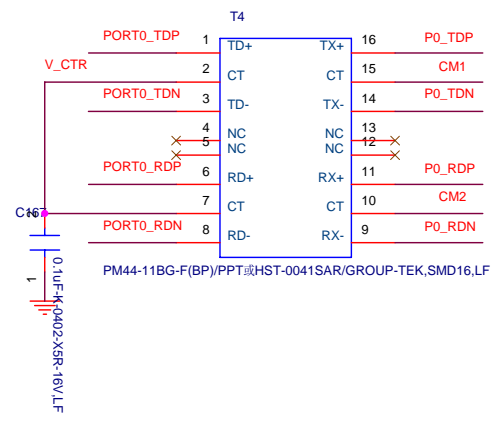
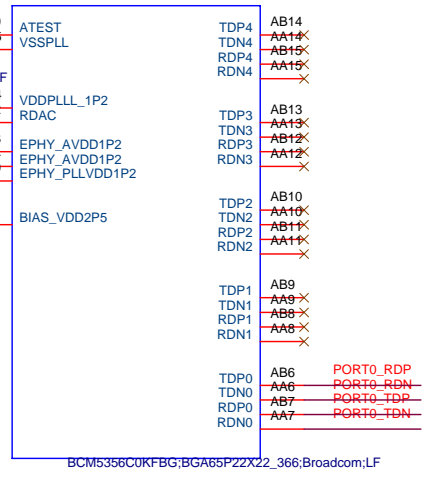

TENDA		
File: A5 - BCM5356C0		
Size: B	Document Number: 05 - Magnetic	Rev: 0.1
Date: Thursday, June 30, 2011	Sheet: 5	of 10

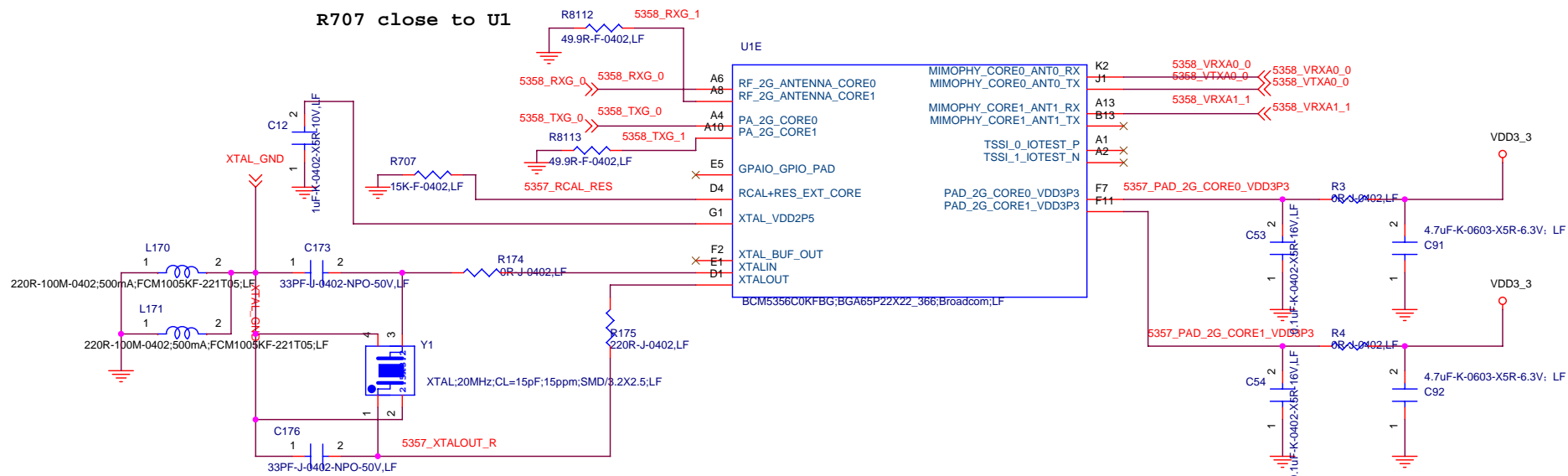

R707 close to U1

XTAL_GND

XTAL has individual ground, connect to GND through internal circuit of U1, L170 and L171

TENDA			
Title: A5 - BCM5356C0			
Size: B	Document Number: 06 - MIMO	Rev: 0.1	
Date: Thursday, June 30, 2011	Sheet: 6	of: 10	

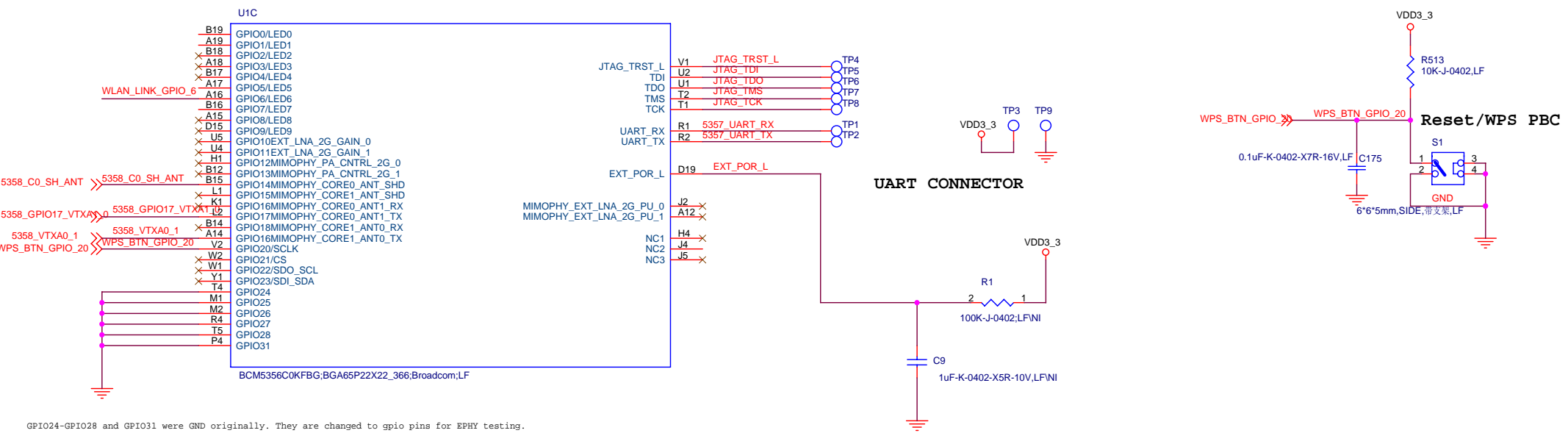

GPIO24-GPIO28 and GPIO31 were GND originally. They are changed to gpio pins for EPHY testing.

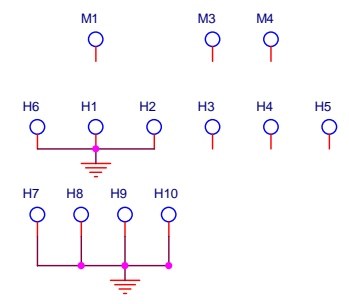
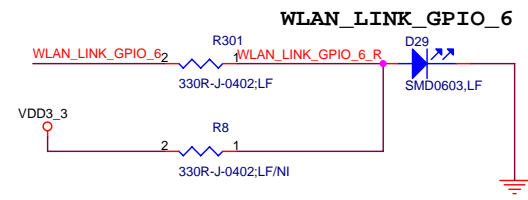

Title		
A5 - BCM5356C0		
Size	Document Number	Rev
B	07 - Misc	0.1
Date:	Friday, July 01, 2011	Sheet 7 of 10

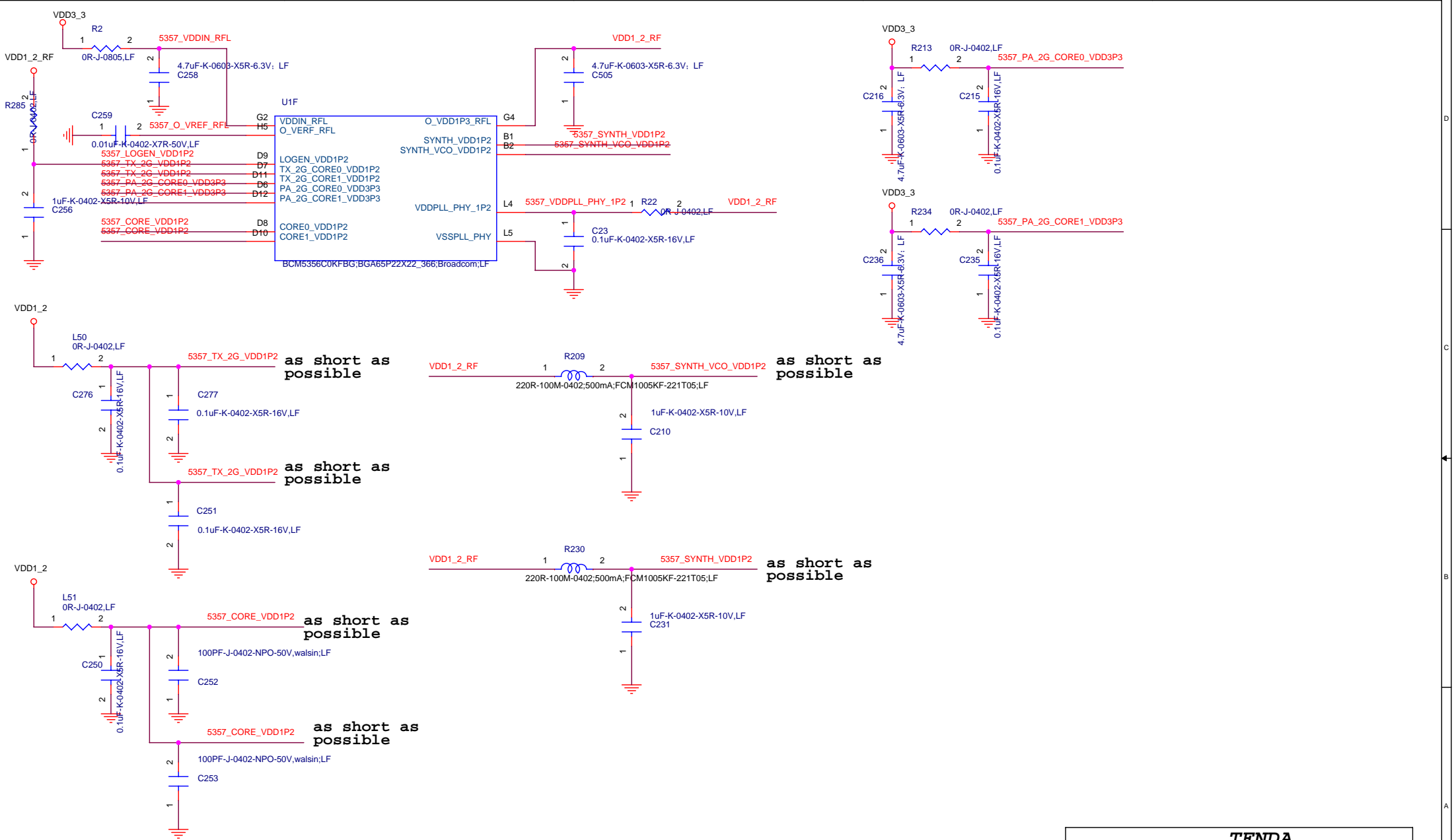

TENDA		
A5 - BCM5356C0		
Size	Document Number	Rev
B	08 Power Module	0.1
Date:	Thursday, June 30, 2011	Sheet 8 of 10

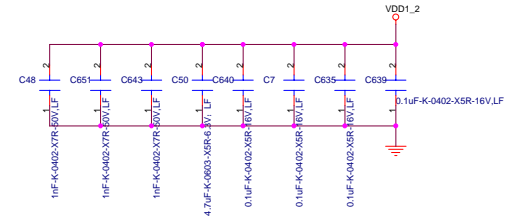
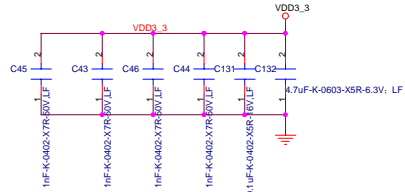
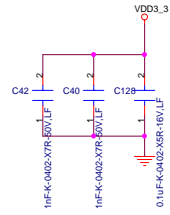
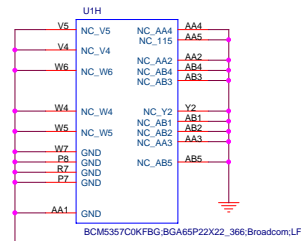
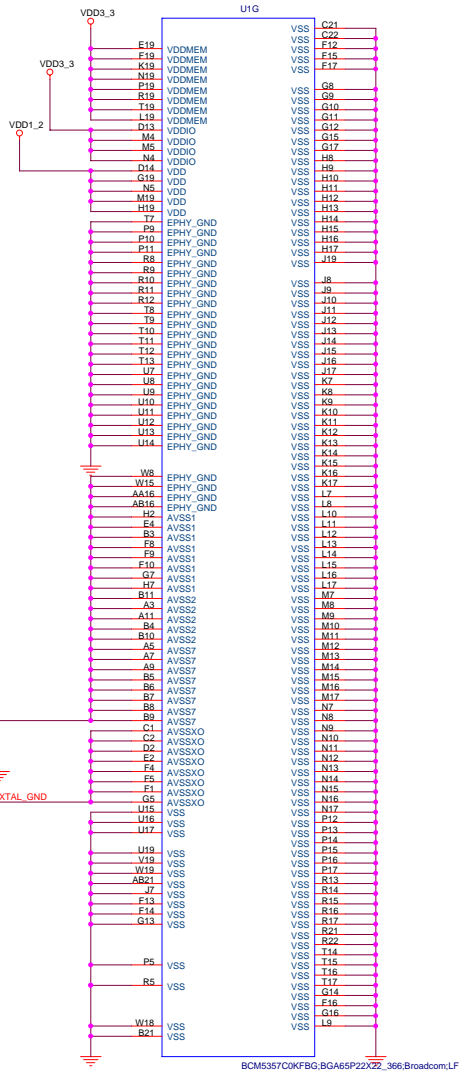

Close to U1

TENDA		
Title	A5 - BCM5356C0	
Size	Document Number	Rev
C	09 Power GND	0.1
Date	Thursday, June 30, 2011	Sheet 9 of 10

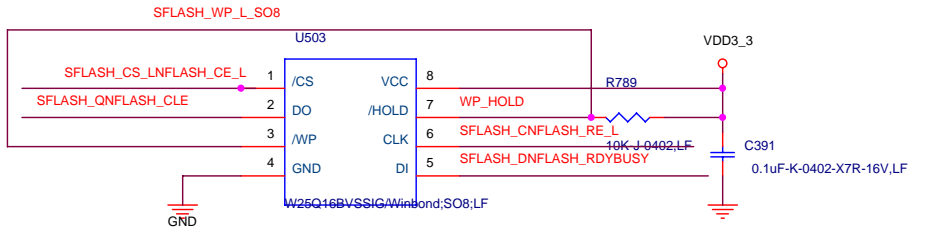
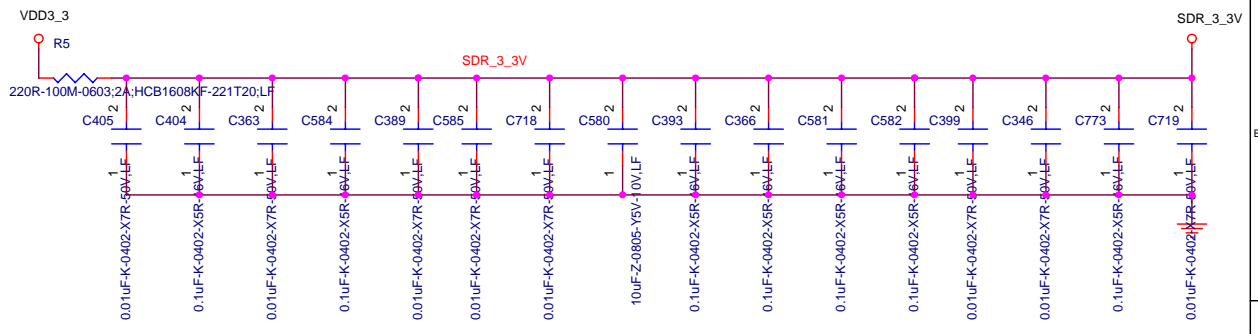
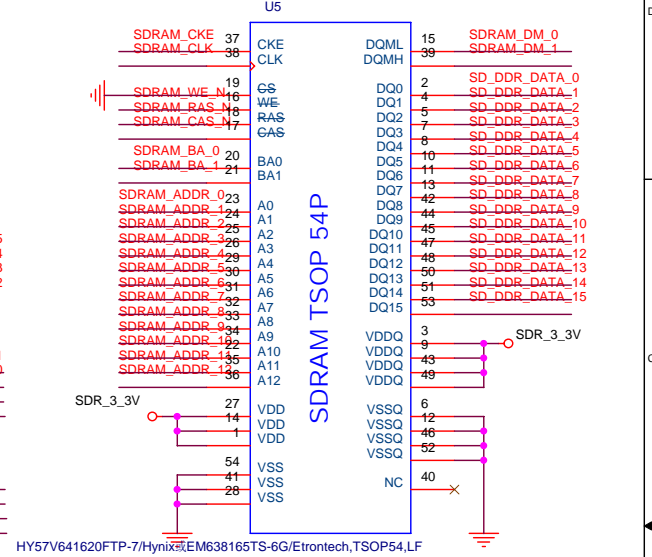
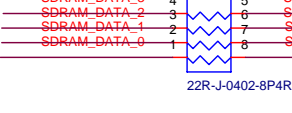
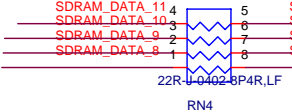
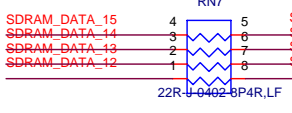
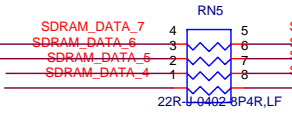
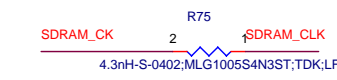
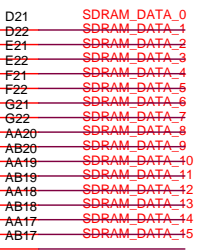
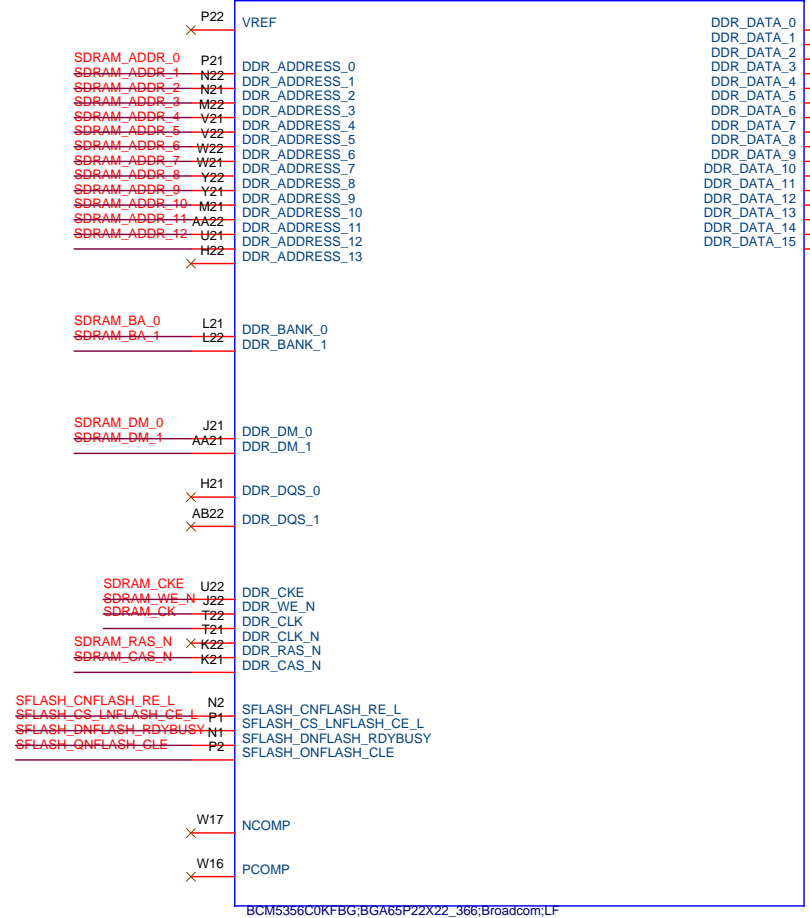

TENDA		
Title	A5 - BCM5356C0	
Size	Document Number	Rev
B	10 - Serial Flash	0.1
Date:	Friday, July 01, 2011	Sheet 10 of 10