

Product Name: 300Mbps Wireless Range Extender
Model number: A30
Trade name: Tenda
Common Product: N/A

TENDA			
Title		A30	
Size	Document Number	Rev	
B	Cover Page	0.3	
Date: Wednesday, December 28, 2011		Sheet	1 of 13

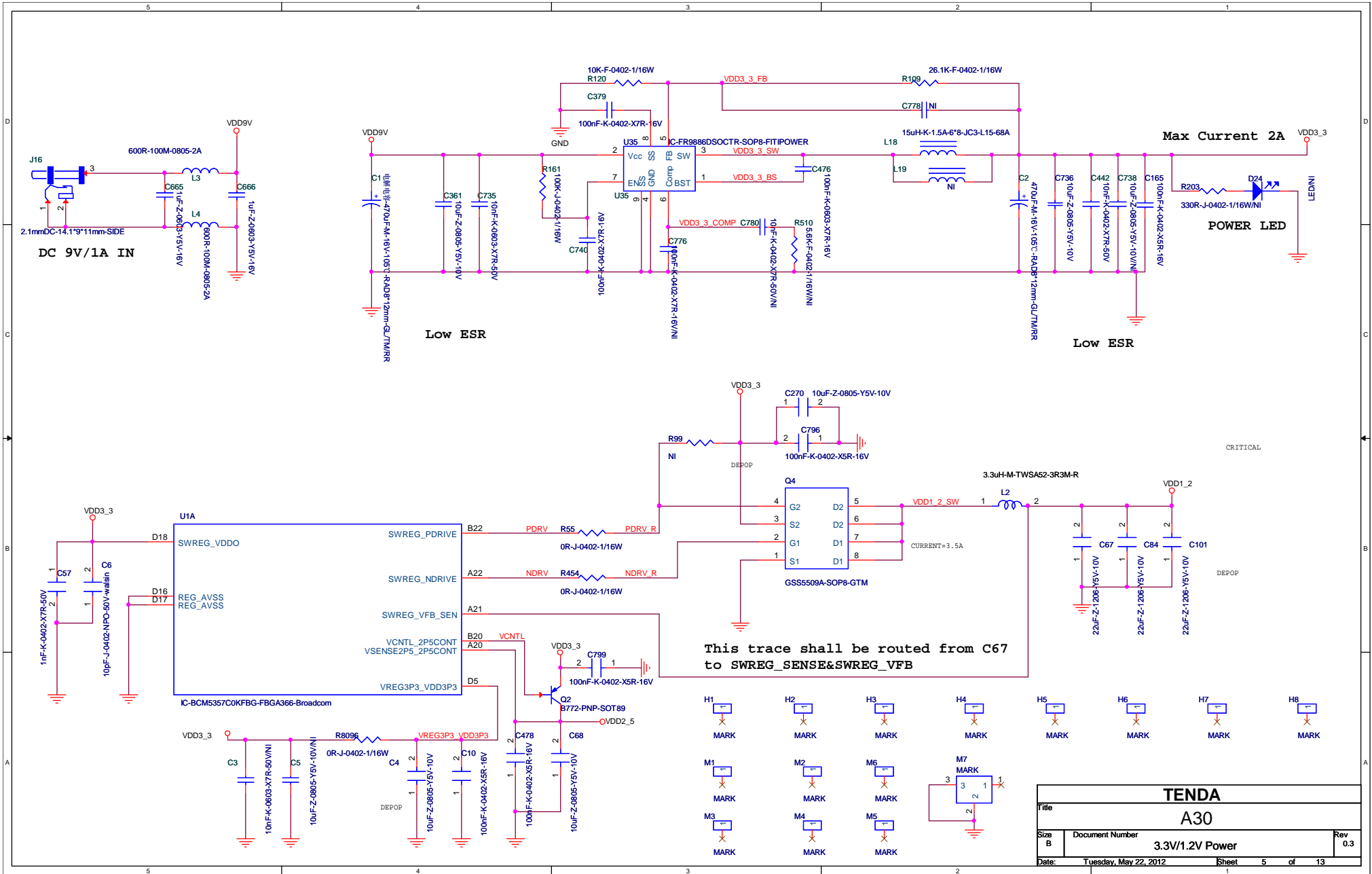

TENDA		
Title A30		
Size B	Document Number 3.3V/1.2V Power	Rev 0.3
Date: Tuesday, May 22, 2012	Sheet 5	of 13

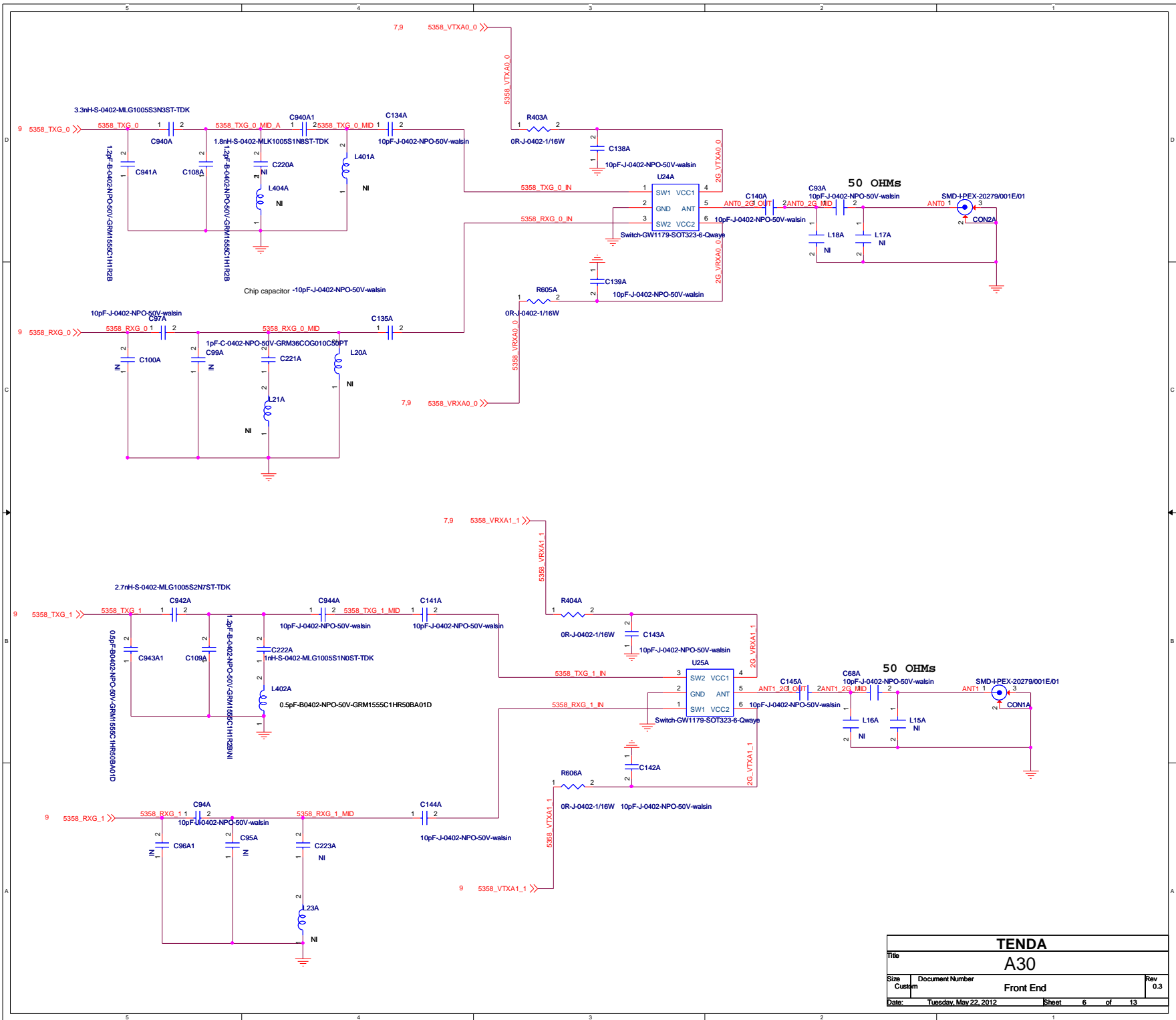

TENDA			
A30			
Size	Document Number	Rev	
Custom	Front End	0.3	
Date:	Tuesday, May 22, 2012	Sheet	6 of 13

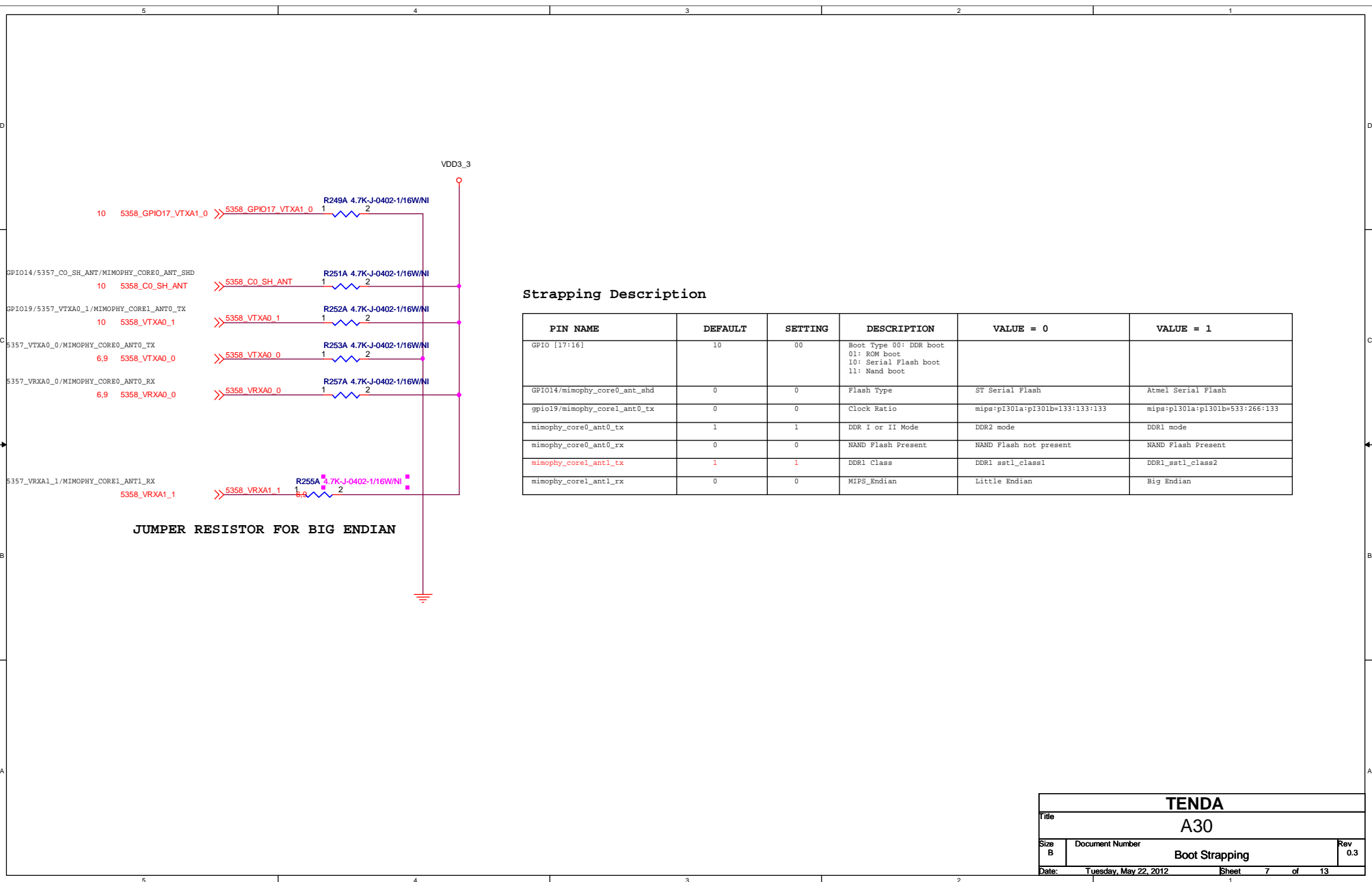

Strapping Description

PIN NAME	DEFAULT	SETTING	DESCRIPTION	VALUE = 0	VALUE = 1
GPIO [17:16]	10	00	Boot Type 00: DDR boot 01: ROW boot 10: Serial Flash boot 11: Nand boot		
GPIO14/mimophy_core0_ant_shd	0	0	Flash Type	ST Serial Flash	Atmel Serial Flash
gpio19/mimophy_core1_ant0_tx	0	0	Clock Ratio	mips:pl301a:pl301b:133:133:133	mips:pl301a:pl301b:533:266:133
mimophy_core0_ant0_tx	1	1	DDR I or II Mode	DDR2 mode	DDR1 mode
mimophy_core0_ant0_rx	0	0	NAND Flash Present	NAND Flash not present	NAND Flash Present
mimophy_core1_ant1_tx	1	1	DDR1 Class	DDR1_ast1_class1	DDR1_ast1_class2
mimophy_core1_ant1_rx	0	0	MIPS_Endian	Little Endian	Big Endian

TENDA		
Title A30		
Size B	Document Number Boot Strapping	Rev 0.3
Date: Tuesday, May 22, 2012	Sheet 7 of 13	1

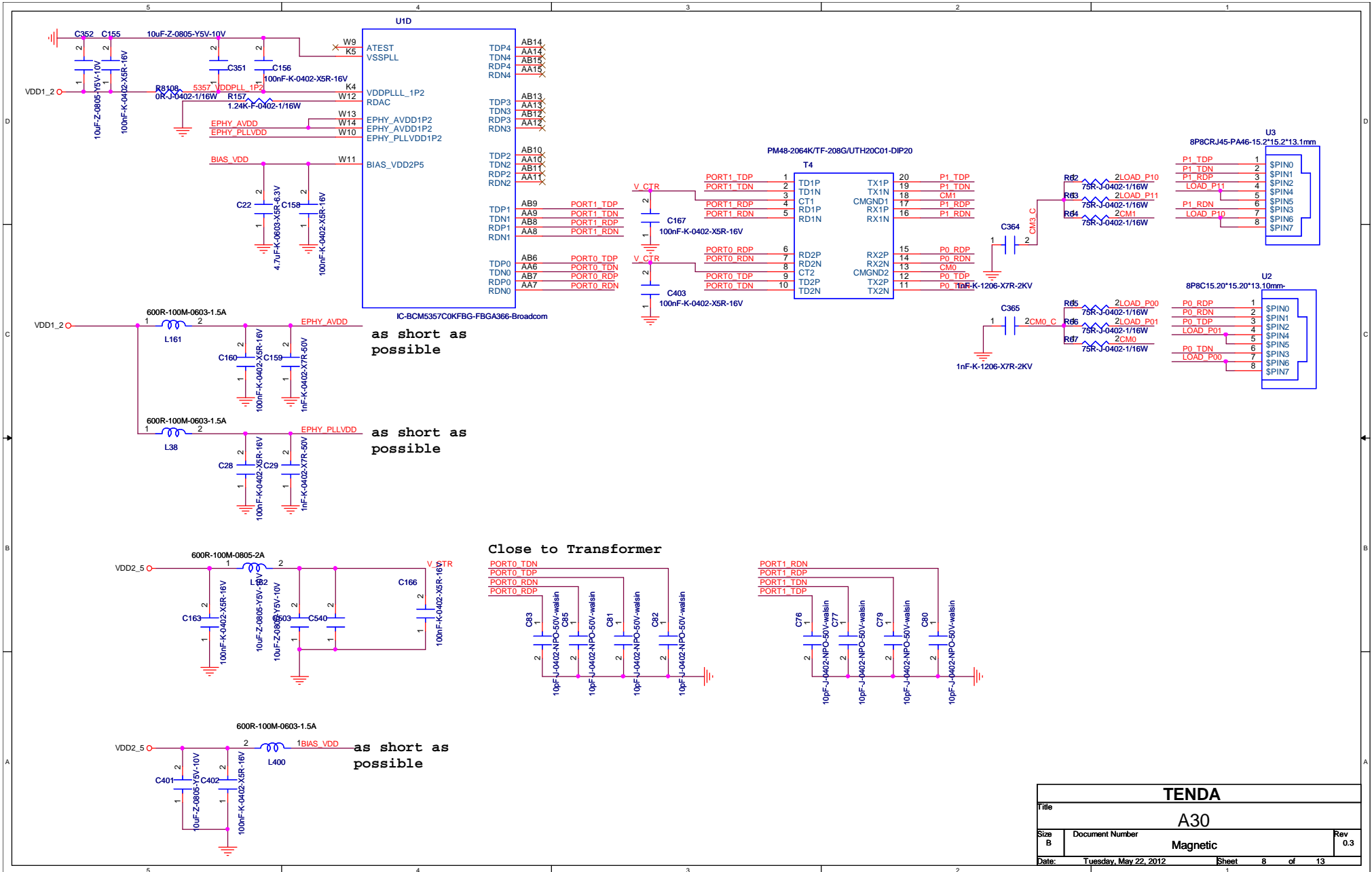

R707 close to U1

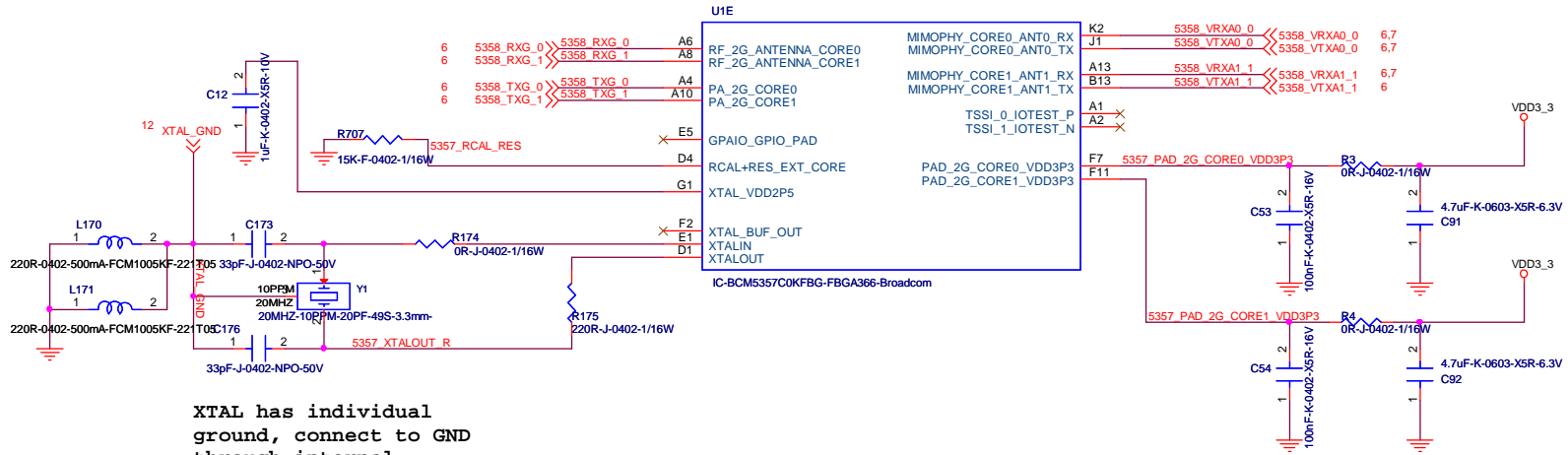

XTAL has individual ground, connect to GND through internal circuit of U1, L170 and L171

TENDA		
Title		
A30		
Size	Document Number	Rev
B	MIMO	0.3
Date:	Tuesday, May 22, 2012	Sheet 9 of 13

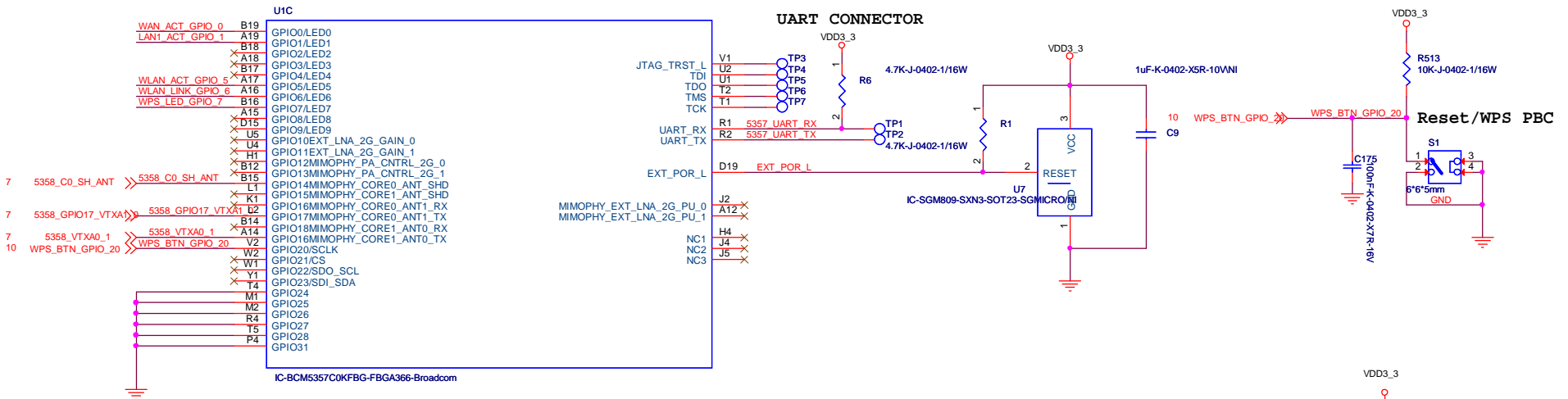

GPIO24-GPIO28 and GPIO31 were GND originally. They are changed to gpio pins for EPHY testing.

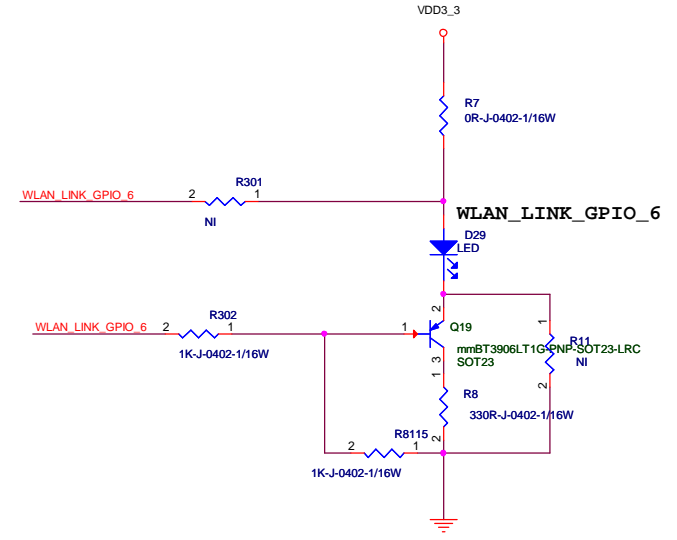
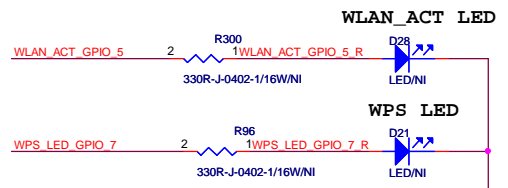
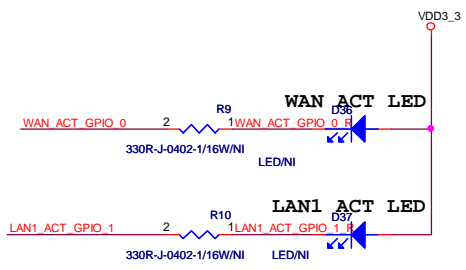

TENDA		
Title		
A30		
Size	Document Number	Rev
B	Misc	0.3
Date:	Wednesday, December 28, 2011	Sheet 10 of 13

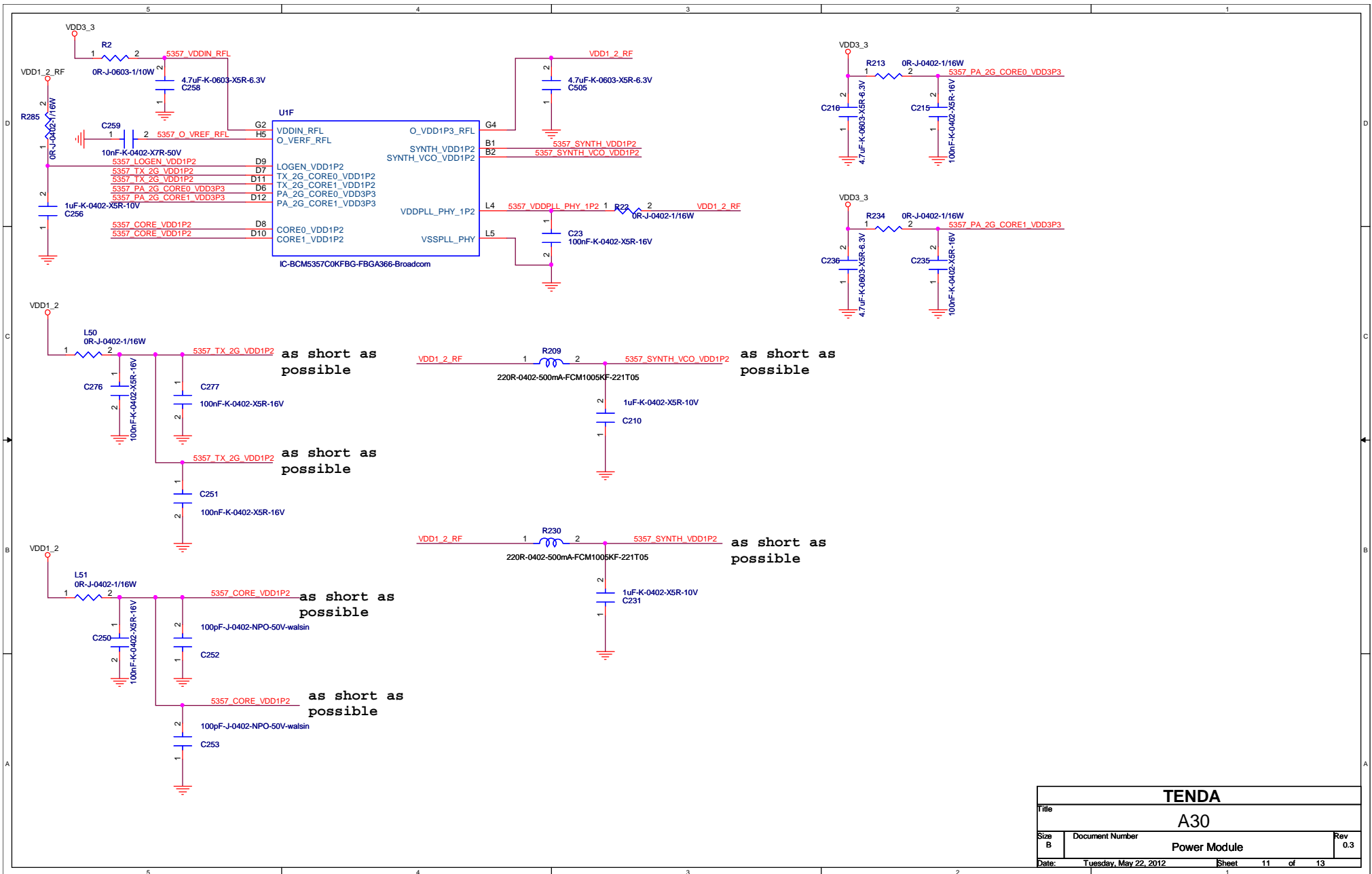

TENDA		
Title		
A30		
Size	Document Number	Rev
B	Power Module	0.3
Date:	Tuesday, May 22, 2012	Sheet 11 of 13

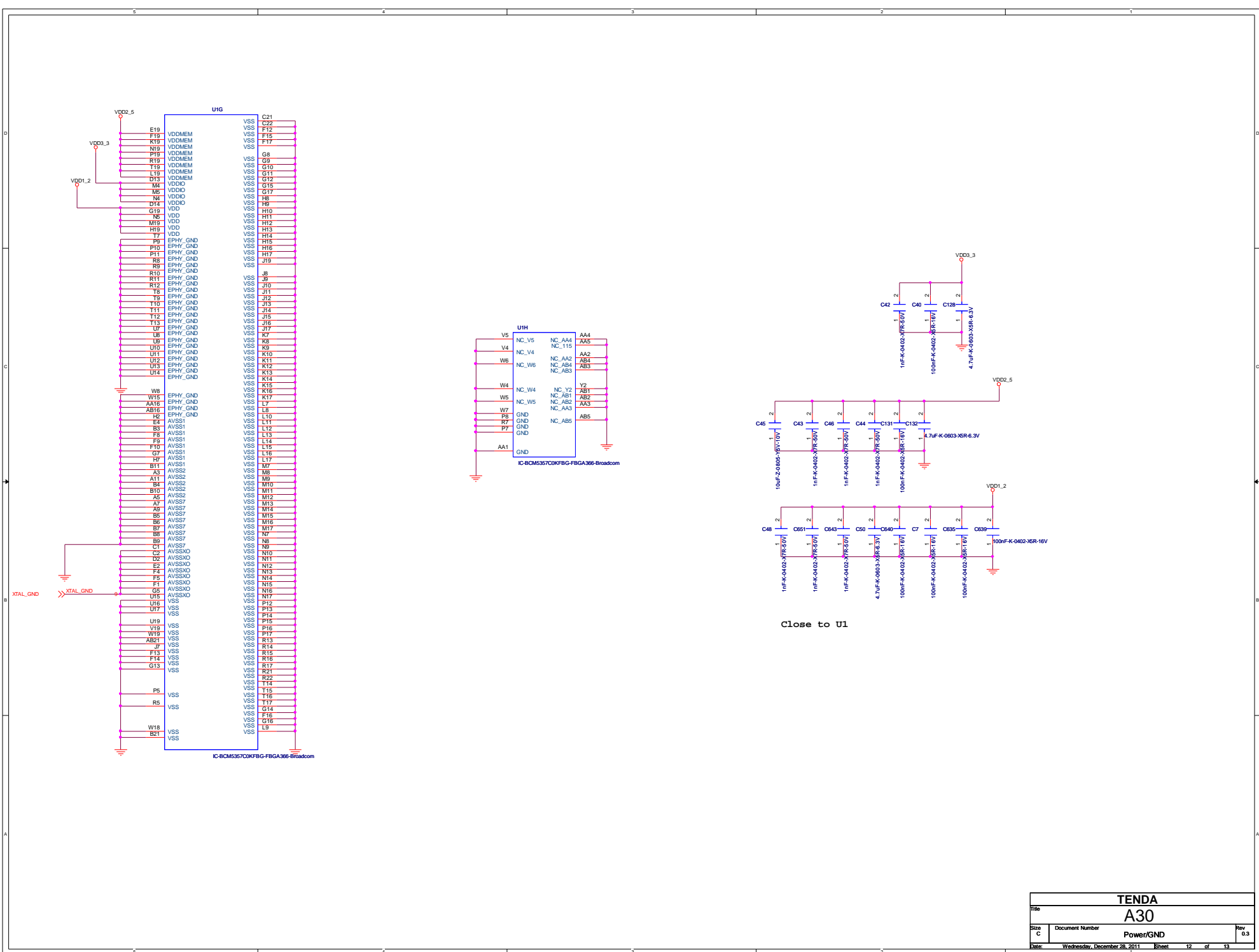

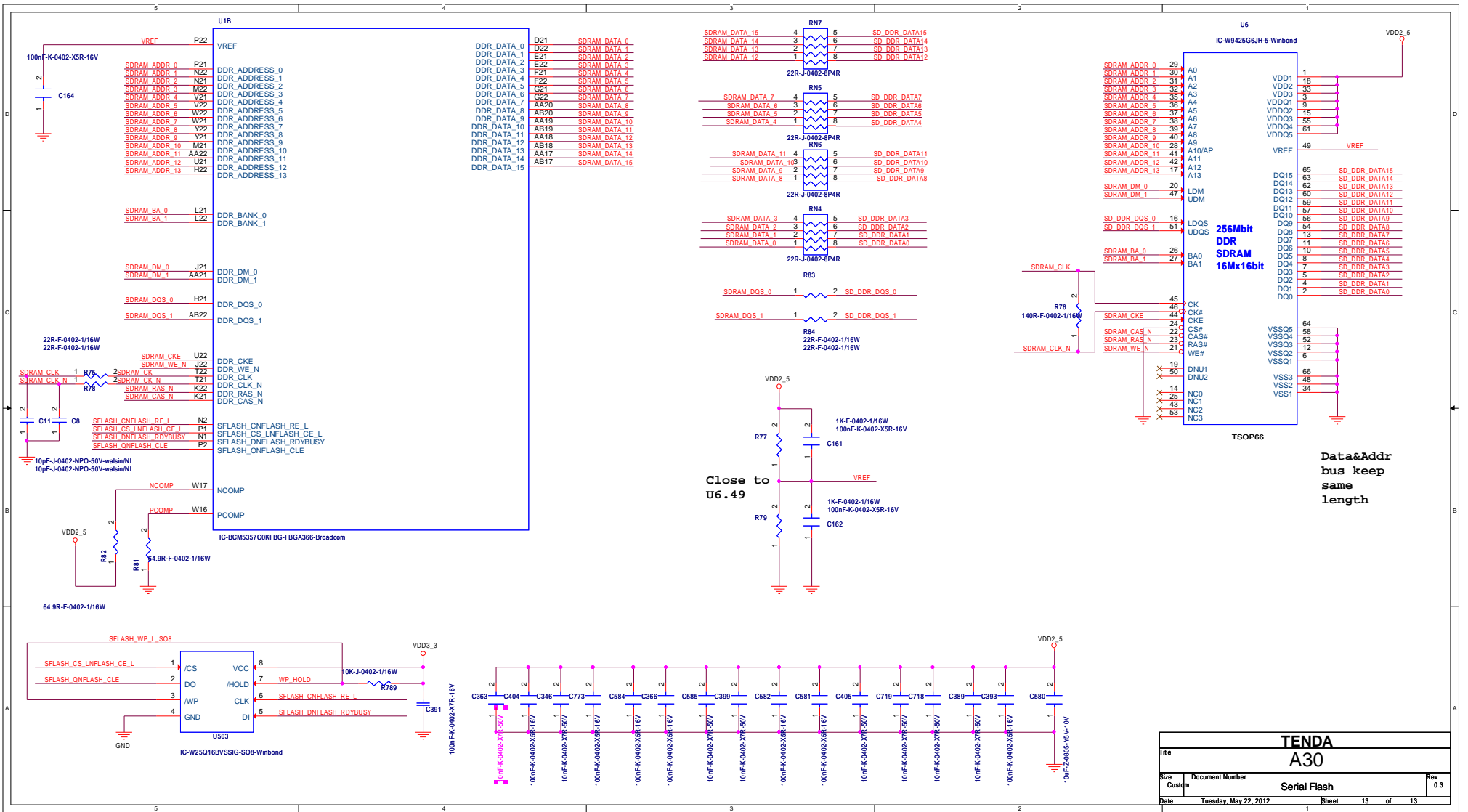

Title		
TENDA		
A30		
Size	Document Number	Rev
Custom	Serial Flash	0.3
Date:	Tuesday, May 22, 2012	Sheet 13 of 13