

MorphoAccess™

Installation Guide

MA500 Series



Produced by Sagem Sécurité

Copyright ©2007 Sagem Sécurité

www.sagem-securite.com

MorphoAccess™ Installation guide
OMA520/521 and MA500/520/521

May 08
SK 53018



Sagem Sécurité

SAFRAN Group

Siège social: Le Ponant de Paris

27, rue Leblanc - 75512 PARIS CEDEX 15 - FRANCE

CONTENTS

INTRODUCTION	5
SAFETY INSTRUCTIONS	6
EUROPE INFORMATION:	6
USA INFORMATION	7
CANADIAN INFORMATION	7
GENERAL DESCRIPTION	8
MA5XX VERSIONS INSTALLATION PROCEDURE	10
STAGE 1: DRILLING THE MOUNTING HOLES	10
STAGE 2: MOUNTING THE METAL CHASSIS ASSEMBLY	11
STAGE 3: CONNECTING THE CHASSIS ASSEMBLY TO THE COVER ASSEMBLY	12
STAGE 4: CLOSING MORPHOACCESS™	13
OMA5XX VERSIONS INSTALLATION PROCEDURE	14
STAGE 1: DRILLING THE MOUNTING HOLES	14
STAGE 2: OMA5XX FIXING	15
STAGE 3: OMA5XX CABLING	15
STAGE 4: CLOSING OMA5XX	15
ELECTRICAL INTERFACE	ERREUR ! SIGNET NON DÉFINI.
MA5XX TERMINAL BLOCK BOARD WIRING	ERREUR ! SIGNET NON DÉFINI.
OMA5XX REAR VIEW AND CABLES	ERREUR ! SIGNET NON DÉFINI.
POWER SUPPLY SOURCE	ERREUR ! SIGNET NON DÉFINI.
WIEGAND OUTPUT WIRING	ERREUR ! SIGNET NON DÉFINI.
DATA CLOCK OUTPUT WIRING	ERREUR ! SIGNET NON DÉFINI.
WIEGAND INPUT WIRING	ERREUR ! SIGNET NON DÉFINI.
DATA CLOCK INPUT WIRING	ERREUR ! SIGNET NON DÉFINI.
COM RS422 SERIAL PORT	ERREUR ! SIGNET NON DÉFINI.
COM RS485 SERIAL PORT	ERREUR ! SIGNET NON DÉFINI.
ETHERNET WIRING	ERREUR ! SIGNET NON DÉFINI.
OUTPUT RELAY AND SECURITY SWITCHES	ERREUR ! SIGNET NON DÉFINI.
USER INTERFACE	ERREUR ! SIGNET NON DÉFINI.

MORPHOACCESS™ MA5XX SERIES TECHNICAL CHARACTERISTICS

ERREUR ! SIGNET NON DÉFINI.

MAN MACHINE INTERFACE	ERREUR ! SIGNET NON DÉFINI.
BIOMETRY	ERREUR ! SIGNET NON DÉFINI.
PERIPHERALS INTERFACES	ERREUR ! SIGNET NON DÉFINI.
POWER SUPPLY	ERREUR ! SIGNET NON DÉFINI.
SIZE AND WEIGHT	ERREUR ! SIGNET NON DÉFINI.
ENVIRONNEMENTAL CONDITIONS	ERREUR ! SIGNET NON DÉFINI.

RECOMMENDATIONS

ERREUR ! SIGNET NON DÉFINI.

AREAS CONTAINING COMBUSTIBLES	ERREUR ! SIGNET NON DÉFINI.
GENERAL PRECAUTIONS	ERREUR ! SIGNET NON DÉFINI.
SPECIFIC PRECAUTIONS FOR RADIO TERMINALS	ERREUR ! SIGNET NON DÉFINI.
ETHERNET CONNECTION	ERREUR ! SIGNET NON DÉFINI.
DATE / TIME SYNCHRONIZATION	ERREUR ! SIGNET NON DÉFINI.
CLEANING PRECAUTIONS	ERREUR ! SIGNET NON DÉFINI.
WARNING	ERREUR ! SIGNET NON DÉFINI.
BIOMETRICS TERMINALS HOT LINE	ERREUR ! SIGNET NON DÉFINI.

APPENDIX 1 - FINGERPRINT PLACEMENT RULES

ERREUR ! SIGNET NON DÉFINI.

APPENDIX 2 – RELATED DOCUMENTS

ERREUR ! SIGNET NON DÉFINI.

APPENDIX 3 - DRILLING TEMPLATE

ERREUR ! SIGNET NON DÉFINI.

MA5XX VERSIONS	ERREUR ! SIGNET NON DÉFINI.
OMA5XX VERSIONS	ERREUR ! SIGNET NON DÉFINI.

SUPPORT

ERREUR ! SIGNET NON DÉFINI.

CUSTOMER SERVICE	ERREUR ! SIGNET NON DÉFINI.
HOTLINE	ERREUR ! SIGNET NON DÉFINI.

INTRODUCTION

Congratulations for choosing the SAGEM MorphoAccess™¹ Automatic Fingerprint Recognition Terminal. MorphoAccess™ provides an innovative and effective solution for access control applications using Fingerprint Verification or/ and Identification.

Among a range of alternative biometric techniques, the use of finger imaging has significant advantages: each finger constitutes an unalterable physical signature which develops before birth and is preserved until death. Unlike DNA, a finger image is unique to each individual - even identical twins.

The MorphoAccess™ terminal integrates SAGEM image processing and feature matching algorithms (MorphoSoft™ and MorphoImaging™). This technology is based on lessons learned during more than 20 years of experience in the field of biometric identification and the creation of literally millions of individual fingerprint identification records.

We believe you will find the SAGEM MorphoAccess™ fast, accurate, easy to use and suitable for physical access control.

The SAGEM MorphoAccess™ offers the following advantages:

- High quality optical sensor (IQS certified)
- Supports multiple input/output interfaces used in the physical access control industry.
- Local area network interface for easy interaction with other host systems.
- Compact size for easy installation and integration into your available office space.
- Intuitive man machine interface with keyboard and display, that is easy to use in both setup and operational modes.
- Open architecture, with dedicated applications implemented via MA5xx/1xx Software Development Kit.

To ensure the most effective use of your SAGEM MorphoAccess™, we recommend that you read this Installation Guide thoroughly.

¹ The SAGEM logo and trademark are the property of *SAGEM Sécurité*.

All other trademarks or product names are trademarks or product names of the respective title holders.

SAFETY INSTRUCTIONS

The installation of this product should be made by a qualified service technician and should conform to all local codes.

It is strongly recommended that a class II power supply at 12 V \pm 5% and 1.5 A. min be used in accordance with Safety Electrical Low Voltage (SELV) parameters. The 12 V power supply cable length should not exceed 5 meters.

This product may be installed with a power supply conforming to EN60950, in accordance with the NEC Class 2 requirements; or supplied by a listed EN60950 external Power Unit marked Class 2, Limited Power source, or LPS and rated 12 V DC, 1.5 A minimum.

In case of "Power Over Ethernet" use, the POE hub or switch features has to be conformed with IEEE 802.3-af standard. An insulation greater than 2000V is provided between MA5xx terminal and Ethernet network.

In case of building to building connection it is recommended to connect 0V to ground. This ground (ground security reference) cable must be connected with the terminal block board fixation screw marked with the universal ground symbol (see p16).

Europe information:

SAGEM hereby declares that the SAGEM MorphoAccess™ has been tested and found compliant with the following listed standards as required by the EMC Directive 89/336/EEC: EN55022 (1994) / EN55024 (1998), EN300-330 (1999) and by the low voltage Directive 73/23/EEC amended by 93/68/EEC: EN60950 (2000).

Caution: The MA5xx terminals are Class A devices. In a residential environment, these devices may cause interference. In this case, the user is encouraged to try to correct the interference with appropriated measures such as:

- Reorient or relocate the receiving antenna.
- Increase the separation between the equipment and receiver.
- Connect the equipment into an outlet on a circuit different from that to which the receiver is connected.
- Consult the dealer or an experienced radio/TV technician for help.

USA information

Responsible Party: SAGEM SECURITE , Le Ponant de Paris, 27, rue Leblanc – F 75512 PARIS CEDEX 15 – FRANCE

Caution: Changes or modifications not expressly approved by the party responsible for compliance could void the user's authority to operate the equipment.

This device complies with part 15 Class A of the FCC Rules. Operation is subject to the following two conditions: (1) This device may not cause harmful interference, and (2) this device must accept any interference received, including interference that may cause undesired operation.

Note: This equipment has been tested and found to comply with the limits for a Class A digital device, pursuant to part 15 of the FCC Rules. These limits are designed to provide reasonable protection against harmful interference in a commercial installation. This equipment generates, uses and can radiate radio frequency energy and, if not installed and used in accordance with the instructions, may cause harmful interference to radio communications. Operation of this equipment in a residential area is likely to cause harmful interference in which case the user will be required to correct the interference at their own expense.

Canadian information

This Class A digital apparatus complies with Canadian ICES-003.

Cet appareil numérique de Classe A est conformes à la norme NMB-003 du Canada.

GENERAL DESCRIPTION

MA5xx versions

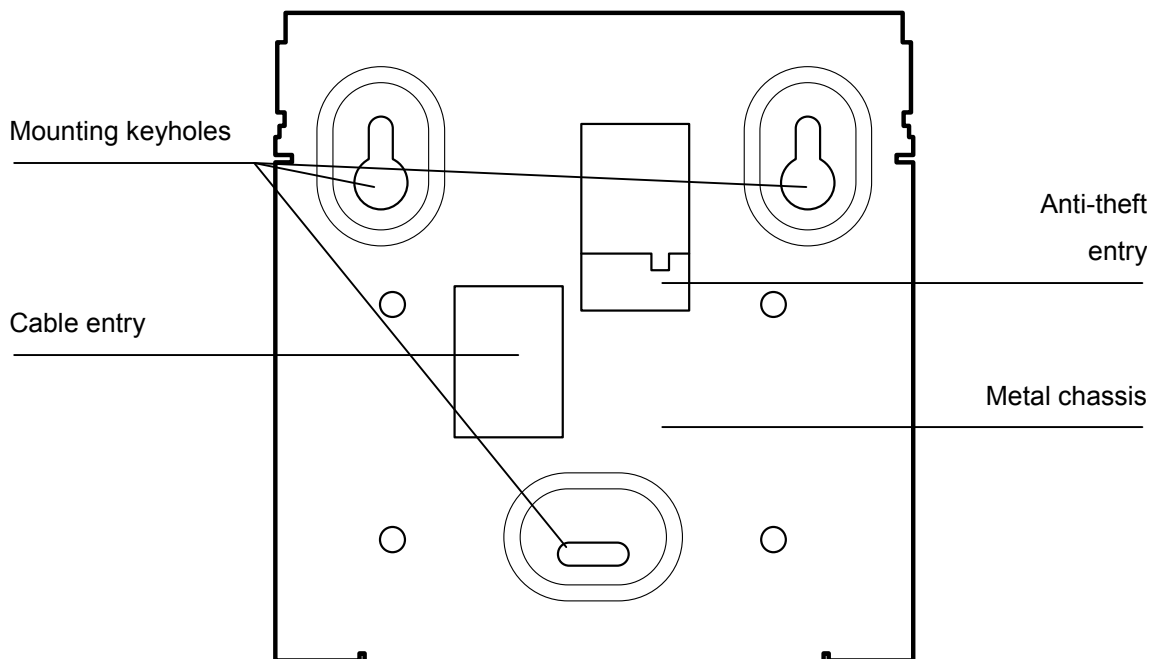

MorphoAccess™ supplies:

- 1 Cover assembly with Chassis and 2 Secured screws for fixation
- 1 Secured screwdriver Torx 20
- 1 Chassis fixation kit (4 fixations and screws , 1 anti theft block)

OMA5xx versions

Protective visor

Display
128 x 64 dots

Function keys

Keyboard

Sensor

MIFARE
Card reader
(MA520 / 521 only)



4 Mounting slots



Outdoor MorphaAccess™ supplies:

- 1 Cover assembly with chassis and protective visor
- 1 Secured screwdriver Torx 10
- 1 Chassis fixation kit (4 fixations and screws)

MA5XX VERSIONS INSTALLATION PROCEDURE

Stage 1: Drilling the mounting holes

Mounting and cable entry hole location (rear view)

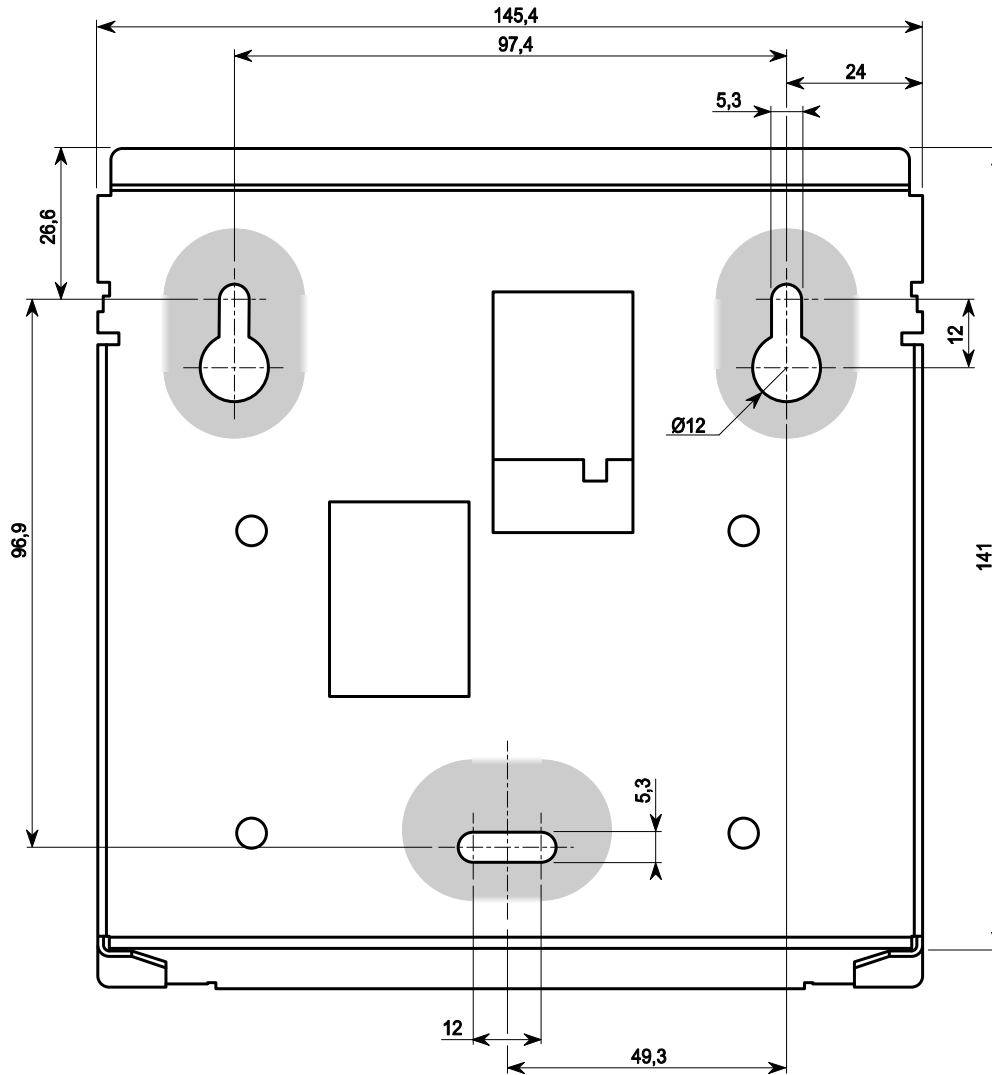

a) Using the dimensional drawing in Appendix 3, drill 2 holes for the mounting keyholes screws so that the cable entry is in a suitable position for cabling.

b) Drill the hole for the third screw in the center of the slot so that it is possible to correct the position later, if necessary.

c) The mounting screws must be 5 mm diameter maximum.

Stage 2: Mounting the metal chassis assembly

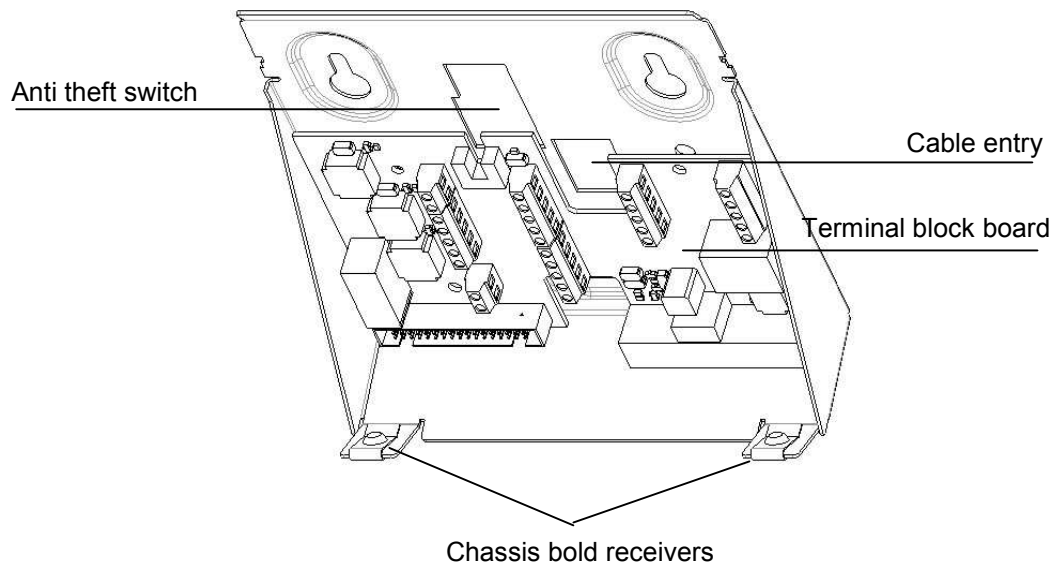

- Disconnect the ribbon cable between the motherboard and the terminal block board so that the assembly shown above can be detached from the rest of MorphoAccess™.
- Pass the connecting cables through the cable entry.
- Position the chassis assembly against the wall using the two screws in the mounting keyholes.
- Hold the chassis in place with a screw through the mounting slot.
- Adjust the position, and fix in place by tightening all three screws.
- Adjust the anti theft block into the hole designed for it, and fix in place the last and fourth screw.

Check that nothing is interfering with the anti theft switch (opto component) and the anti theft block.

- Connect cables to terminal blocks with adequate torque conformed to screw dimensions (see the detailed instructions in the following sections)



Be sure during manipulation that the power supply from the electrical source is off.

Stage 3: Connecting the chassis assembly to the cover assembly

Ribbon cable connector location

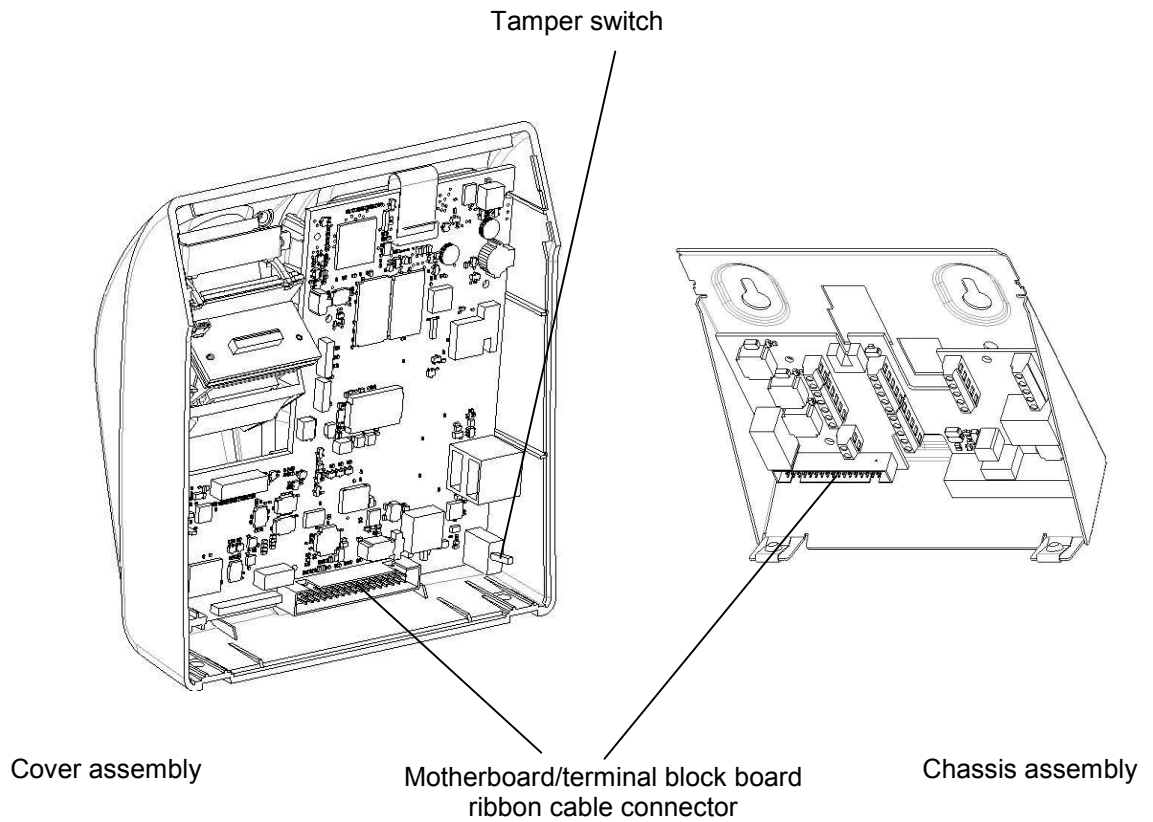

Position of the ribbon cable as the case is closed

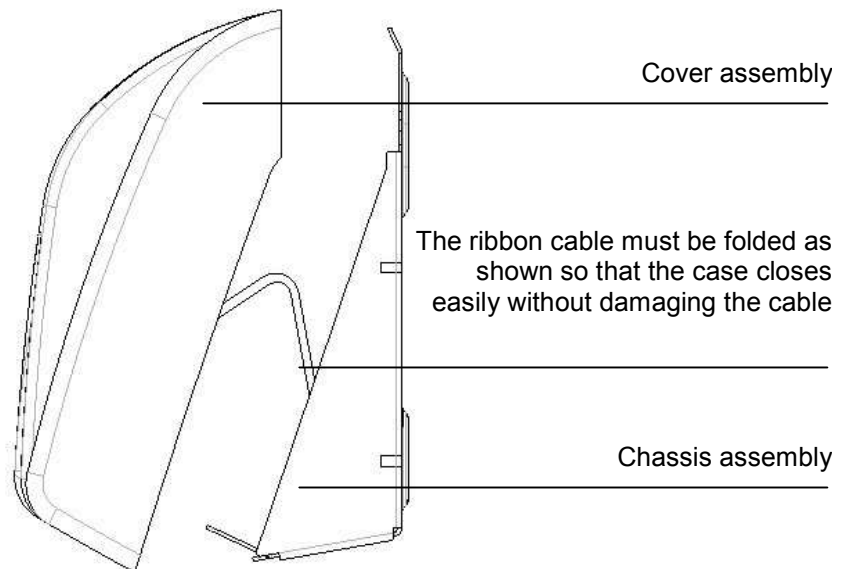

Stage 4: Closing MorphoAccess™

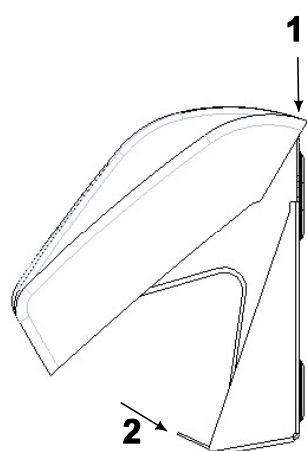
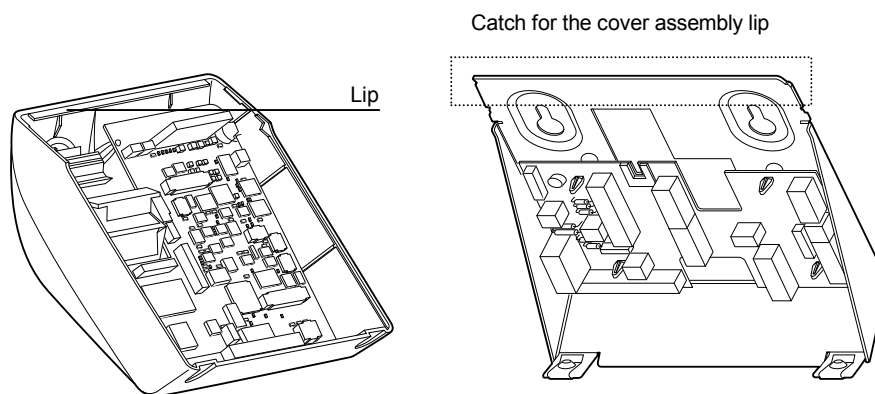

When the ribbon cable has been connected between the two assemblies (see stage 3), the cover assembly is fitted to the chassis assembly.

1 The lip on the cover slides behind the chassis, to fit over the catch shown on the diagram above.

2 The cover is fitted onto the chassis by rotating it.

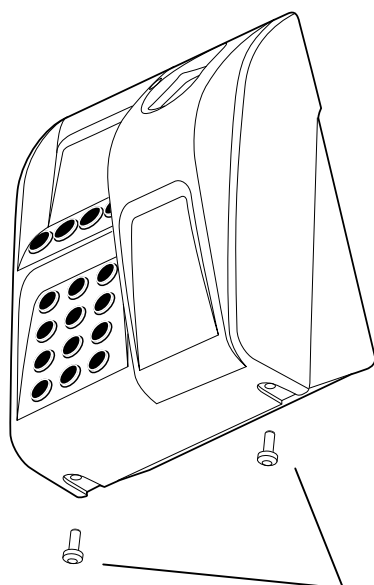

Fit the two M4x16 assembly screws.
Use screwdriver TORX 20

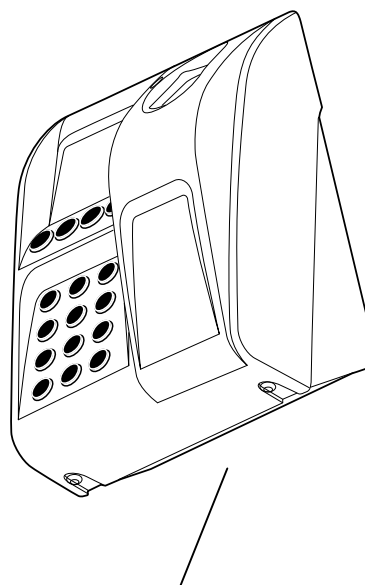

Assembled
MorphoAccess™

OMA5XX VERSIONS INSTALLATION PROCEDURE

Stage 1: Drilling the mounting holes

Mounting hole location (rear view)

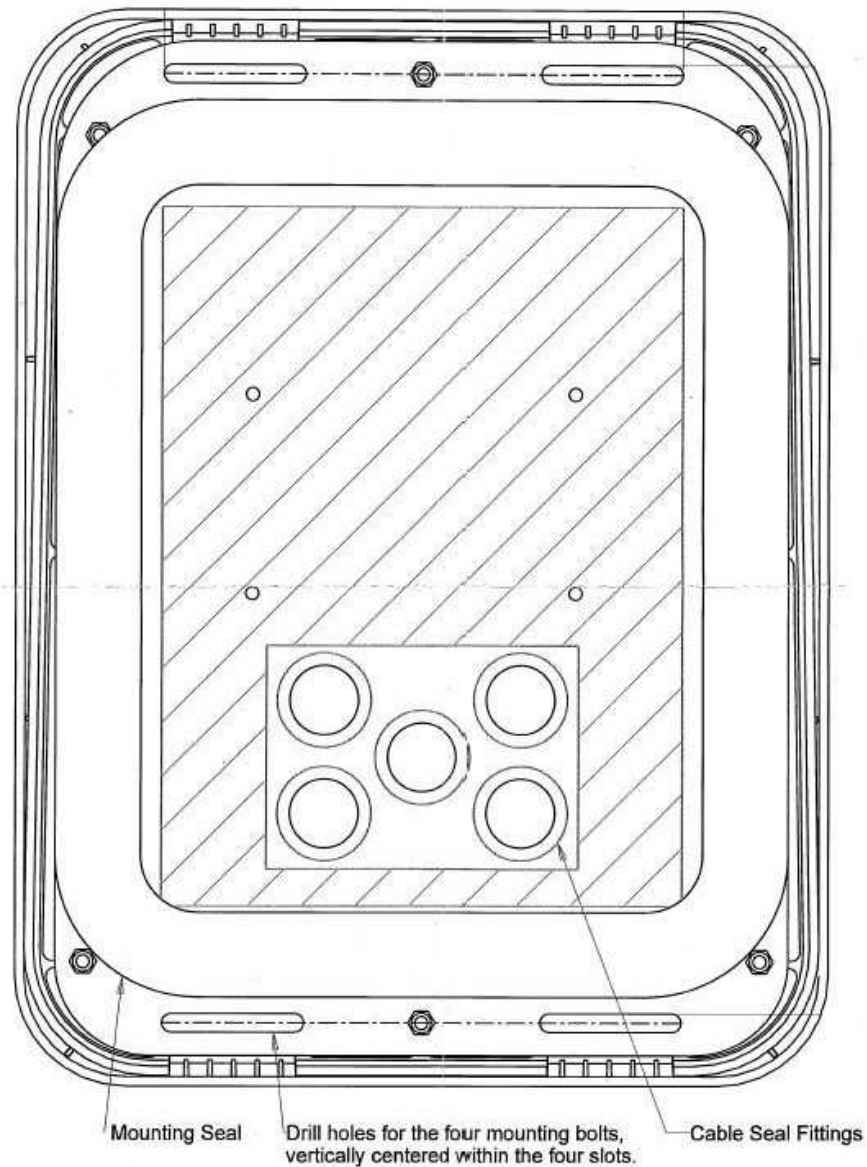

- a) Using the dimensional drawing for OMA5xx in Appendix 3, drill holes for the four mounting bolts, vertically centered within the four slots.
- b) The mounting bolts must be 5 mm diameter maximum.

Stage 2: OMA5xx fixing

- a) Remove protective visor (4 small caps at each corner) before fixing OMA5xx assembly.

Remove the 4 small caps at each corner of the protective visor , with a small screw driver

Remove the 4 screws , with T10 screw driver supplied.

- b) Adjust the OMA5xx assembly in front of the 4 holes.
- c) Fix the 4 mounting bolts (2 in upper zone , 2 in lower zone)

Stage 3: OMA5xx cabling

- a) Connect necessary OMA cables to user wires (see the detailed instructions in the following sections)

Stage 4: Closing OMA5xx

- a) Mount protective visor with 4 screws and T10 screw driver.
- b) Put the 4 small caps.