

TEST REPORT

Report No.: 19100289HKG-001

ThinkGeek, Inc.

Application For Certification
(Original Grant)

FCC ID: V77-LJSL-MV-IRN

Transmitter

Prepared and Checked by:

Approved by:



Henry Lu
Engineer
UnionTrust Quality and Technology Co., Ltd.
Date: November 18, 2019

Chan Chi Hung, Terry
Manager
Date: November 18, 2019

Intertek's standard Terms and Conditions can be obtained at our website <http://www.intertek.com/terms/>.

The test report only allows to be revised within the retention period unless further standard or the requirement was noticed.

This report is for the exclusive use of Intertek's Client and is provided pursuant to the agreement between Intertek and its Client. Intertek's responsibility and liability are limited to the terms and conditions of the agreement. Intertek assumes no liability to any party, other than to the Client in accordance with the agreement, for any loss, expense or damage occasioned by the use of this report. Only the Client is authorized to permit copying or distribution of this report and then only in its entirety. Any use of the Intertek name or one of its marks for the sale or advertisement of the tested material, product or service must first be approved in writing by Intertek. The observations and test results in this report are relevant only to the sample tested. This report by itself does not imply that the material, product, or service is or has ever been under an Intertek certification program.

© 2017 Intertek

TEST REPORT

GENERAL INFORMATION

Grantee:	ThinkGeek, Inc.
Grantee Address:	625 Westport Parkway, Grapevine, TX 76051, United States
Contact Person:	Elizabeth Sullivan
Tel:	817-424-2087
Fax:	N/A
e-mail:	elizabethsullivan@gamestop.com
Manufacturer:	ThinkGeek, Inc.
Manufacturer Address:	625 Westport Parkway, Grapevine, TX 76051, United States
Brand Name:	Iron Man Wireless Charger
Model:	LJSL-MV-IRN
Type of EUT:	Transmitter
Description of EUT:	Wireless Charger
Serial Number:	N/A
FCC ID:	V77-LJSL-MV-IRN
Date of Sample Submitted:	October 10, 2019
Date of Test:	October 24, 2019 to November 04, 2019
Report No.:	19100289HKG-001
Report Date:	November 18, 2019
Environmental Conditions:	Temperature: +10 to 40°C Humidity: 10 to 90%
Conclusion:	Test was conducted by client submitted sample. The submitted sample as received complied with the 47 CFR Part 15 Certification.

TEST REPORT

SUMMARY OF TEST RESULT

Test Specification	Reference	Results
Transmitter Power Line Conducted Emissions	15.207	Pass
Radiated Emission	15.209	Pass
Radiated Emission on the Bandedge		

The equipment under test is found to be complying with the following standards:
FCC Part 15, October 1, 2018 Edition

- Note:
1. The EUT uses a permanently attached antenna which, in accordance to section 15.203, is considered sufficient to comply with the provisions of this section.
 2. Pursuant to FCC part 15 Section 15.215(c), the 20 dB bandwidth of the emission was contained within the frequency band designated (mentioned as above) which the EUT operated. The effects, if any, from frequency sweeping, frequency hopping, other modulation techniques and frequency stability over excepted variations in temperature and supply voltage were considered.

TEST REPORT

TABLE OF CONTENTS

1.0	GENERAL DESCRIPTION	5
1.1	Product Description	5
1.2	Related Submittal(s) Grants.....	5
1.3	Test Methodology	5
1.4	Test Facility	5
2.0	SYSTEM TEST CONFIGURATION	6
2.1	Justification	6
2.2	EUT Exercising Software	6
2.3	Special Accessories.....	6
2.4	Measurement Uncertainty	6
2.5	Support Equipment List and Description.....	6
3.0	EMISSION RESULTS.....	7
3.1	Field Strength Calculation.....	7
3.2	Radiated Emission Configuration Photograph.....	8
3.3	Radiated Emission Data.....	8
3.4	Conducted Emission Configuration Photograph	8
3.5	Conducted Emission Data.....	8
4.0	EQUIPMENT PHOTOGRAPHS	14
5.0	PRODUCT LABELLING.....	14
6.0	TECHNICAL SPECIFICATIONS	14
7.0	INSTRUCTION MANUAL.....	14
8.0	MISCELLANEOUS INFORMATION	15
8.1	Measured Bandwidth.....	15
8.2	Discussion of Pulse Desensitization	15
8.3	Calculation of Average Factor	15
8.4	Emissions Test Procedures	16
9.0	CONFIDENTIALITY REQUEST	20
10.0	EQUIPMENT LIST	20

TEST REPORT

1.0 GENERAL DESCRIPTION

1.1 Product Description

The Equipment Under Test (EUT) is a wireless power transfer device that operating at 110KHz - 205KHz which is powered by adapter. After placing the smartphone on the EUT, it can be charged.

Antenna Type: Internal, Integral

For electronic filing, the brief circuit description is saved with filename: descri.pdf.

1.2 Related Submittal(s) Grants

This is a single application for certification of a transmitter.

1.3 Test Methodology

Both AC mains line-conducted and radiated emission measurements were performed according to the procedures in ANSI C63.10 (2013). All radiated measurements were performed in an 3m Chamber. Preliminary scans were performed in the 3m Chamber only to determine worst case modes. All radiated tests were performed at an antenna to EUT distance of 3 meters, unless stated otherwise in the “**Justification Section**” of this Application.

1.4 Test Facility

The 3m Chamber and conducted measurement facility used to collect the radiated data is located at UnionTrust Quality and Technology Co., Ltd. (16/F, Block A, Building 6, Baoneng Science and Technology Park, Qingxiang Road No.1, Longhua New District, Shenzhen, China). This test facility and site measurement data have been placed on file with the FCC.

TEST REPORT

2.0 SYSTEM TEST CONFIGURATION

2.1 Justification

The system was configured for testing in a typical fashion (as a customer would normally use it), and in the confines as outlined in ANSI C63.10 (2013).

The device was powered by AC/DC adaptor (Input: 100-240V 50/60HZ 0.5A; Output: 5V/3A 9V/2A 12V.15A)

For maximizing emissions below 30 MHz, the EUT was rotated through 360°, the centre of the loop antenna was placed 1 meter above the ground, and the antenna polarization was changed. For maximizing emission at and above 30 MHz, the EUT was rotated through 360°, the antenna height was varied from 1 meter to 4 meters above the ground plane, and the antenna polarization was changed. This step by step procedure for maximizing emissions led to the data report in Exhibit 3.0.

The rear of unit shall be flushed with the rear of the table.

The equipment under test (EUT) was configured for testing in a typical fashion (as a customer would normally use it). The EUT was mounted to a plastic stand if necessary and placed on the wooden turntable, which enabled the engineer to maximize emissions through its placement in the three orthogonal axes.

2.2 EUT Exercising Software

There was no special software to exercise the device. Once the unit is powered up, it transmits the RF signal continuously.

2.3 Special Accessories

There are no special accessories necessary for compliance of this product.

2.4 Measurement Uncertainty

When determining of the test conclusion, the Measurement Uncertainty of test has been considered.

Uncertainty and Compliance - Unless the standard specifically states that measured values are to be extended by the measurement uncertainty in determining compliance, all compliance determinations are based on the actual measured value.

2.5 Support Equipment List and Description

- 1) Adaptor
Model: DBS15Q
Input: 100-240V 50/60HZ 0.5A
Output: 5V/3A 9V/2A 12V.15A
(Provided by Applicant)
- 2) Phone
Model: M1803D5XA
Trade Mark: MI
(Provided by UnionTrust)

TEST REPORT

3.0 EMISSION RESULTS

Data is included of the worst case configuration (the configuration which resulted in the highest emission levels). A sample calculation, configuration photographs and data tables of the emissions are included.

3.1 Field Strength Calculation

The field strength is calculated by adding the Antenna Factor and Cable Factor, and subtracting the Amplifier Gain (if any), Average Factor (optional) from the measured reading. The basic equation with a sample calculation is as follows:

$$FS = RA + AF + CF - AG - AV$$

where FS = Field Strength in dB μ V/m

RA = Receiver Amplitude (including preamplifier) in dB μ V

CF = Cable Attenuation Factor in dB

AF = Antenna Factor in dB

AG = Amplifier Gain in dB

AV = Average Factor in dB

In the following table(s), the reading shown on the data table reflects the preamplifier gain. An example for the calculations in the following table is as follows:

$$FS = RR + LF$$

where FS = Field Strength in dB μ V/m

RR = RA - AG - AV in dB μ V

LF = CF + AF in dB

Assume a receiver reading of 52.0 dB μ V is obtained. The antenna factor of 7.4 dB and cable factor of 1.6 dB are added. The amplifier gain of 29 dB and average factor of 5 dB are subtracted, giving a field strength of 32 dB μ V/m. This value in dB μ V/m was converted to its corresponding level in μ V/m.

$$RA = 52.0 \text{ dB}\mu\text{V/m}$$

$$AF = 7.4 \text{ dB}$$

$$CF = 1.6 \text{ dB}$$

$$AG = 29.0 \text{ dB}$$

$$AV = 5.0 \text{ dB}$$

$$FS = RR + LF$$

$$FS = 18 + 9 = 27 \text{ dB}\mu\text{V/m}$$

$$RR = 18.0 \text{ dB}\mu\text{V}$$

$$LF = 9.0 \text{ dB}$$

$$\text{Level in } \mu\text{V/m} = \text{Common Antilogarithm } [(27 \text{ dB}\mu\text{V/m})/20] = 22.4 \mu\text{V/m}$$

TEST REPORT

3.2 Radiated Emission Configuration Photograph

The worst case in radiated emission was found at 32.640 MHz

For electronic filing, the worst case radiated emission configuration photographs are saved with filename: radiated photos.pdf.

3.3 Radiated Emission Data

The data on the following page lists the significant emission frequencies, the limit and the margin of compliance. Numbers with a minus sign are below the limit.

Judgment: Passed by 7.08 dB

3.4 Conducted Emission Configuration Photograph

The worst case in line-conducted emission was found at 0.850 kHz

For electronic filing, the worst case line-conducted configuration photographs are saved with filename: conducted photo.pdf.

3.5 Conducted Emission Data

For electronic filing, the graph and data table of conducted emission is saved with filename: conducted.pdf.

Judgment: Pass by 8.51 dB

TEST REPORT

CONDUCTED EMISSION

Model: LJSL-MV-IRN

Date of Test: October 24, 2019 to November 04, 2019

Worst-Case Operating Mode: Operating with Max. Power Output

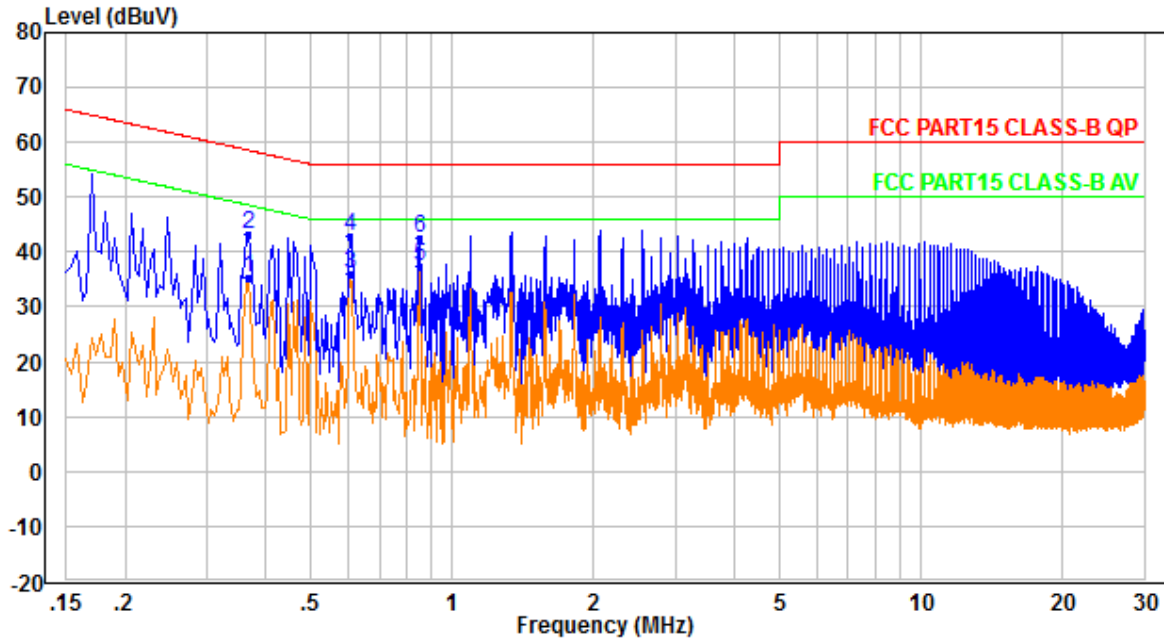

Live Line							
No.	Frequency (MHz)	Reading (dBuV)	Correction factor (dB)	Result (dBuV)	Limit (dBuV)	Margin (dB)	Remark
1	0.366	25.26	9.99	35.25	48.59	-13.34	Average
2	0.366	33.35	9.99	43.34	58.59	-15.25	QP
3	0.606	25.87	10.01	35.88	46.00	-10.12	Average
4	0.606	32.96	10.01	42.97	56.00	-13.03	QP
5	0.850	27.44	10.05	37.49	46.00	-8.51	Average
6	0.850	32.55	10.05	42.60	56.00	-13.40	QP

TEST REPORT

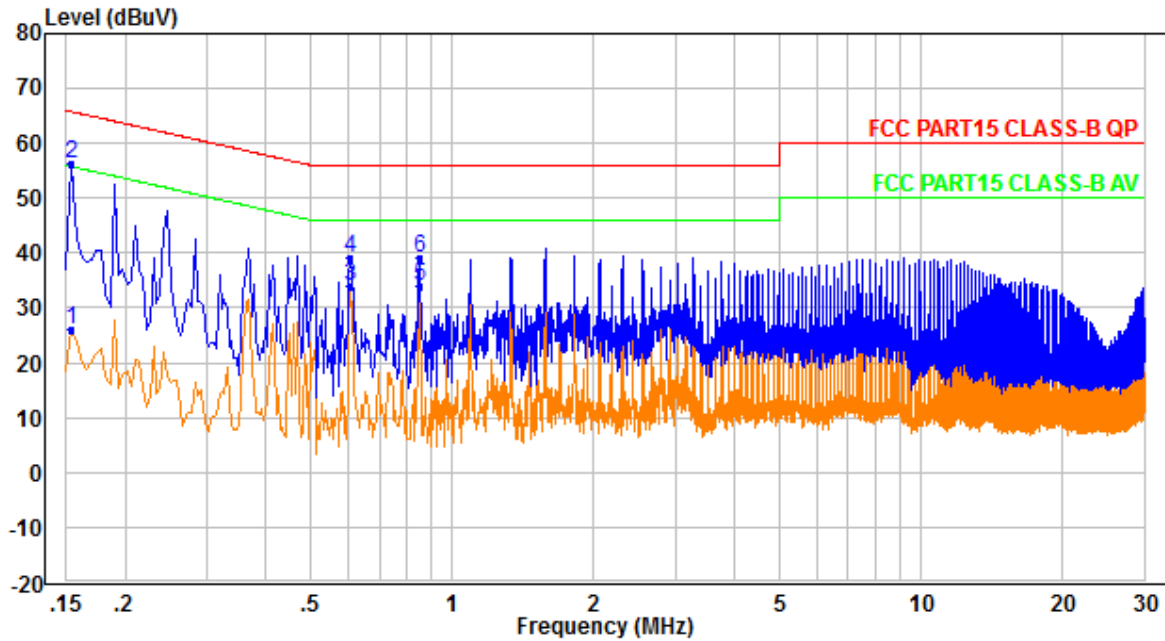

Neutral Line							
No.	Frequency (MHz)	Reading (dBuV)	Correction factor (dB)	Result (dBuV)	Limit (dBuV)	Margin (dB)	Remark
1	0.154	16.13	10.00	26.13	55.78	-29.65	Average
2	0.154	46.30	10.00	56.30	65.78	-9.48	QP
3	0.606	24.00	9.99	33.99	46.00	-12.01	Average
4	0.606	29.07	9.99	39.06	56.00	-16.94	QP
5	0.850	23.89	10.04	33.93	46.00	-12.07	Average
6	0.850	28.98	10.04	39.02	56.00	-16.98	QP

Note: Measurement Uncertainty is ± 4.2 dB at a level of confidence of 95%.

TEST REPORT

RADIATED EMISSIONS

Model: LJSL-MV-IRN

Date of Test: October 24, 2019 to November 04, 2019

Worst-Case Operating Mode: Operating with Max. Power Output

Table 1
Pursuant to FCC Part 15 Section 15.209 Requirement

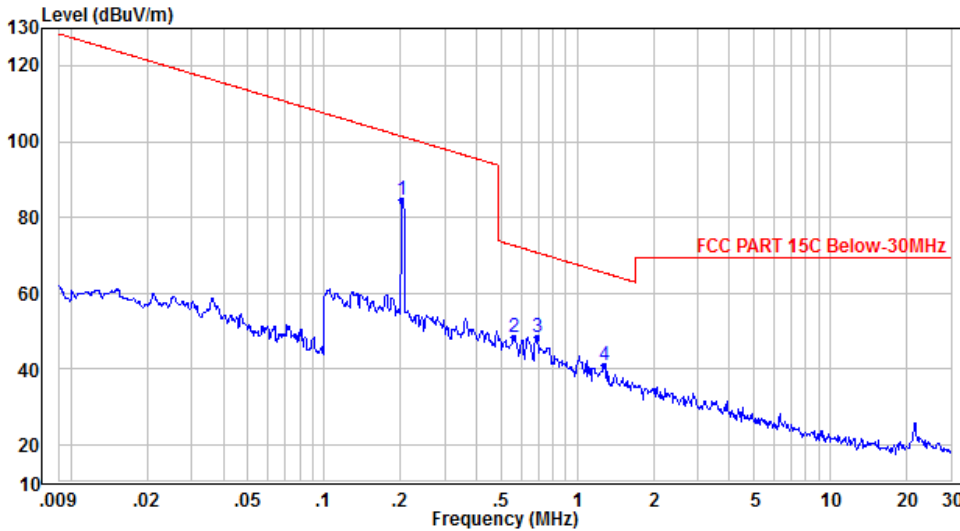

No.	Frequency (MHz)	Reading (dB μ V/m)	Correction factor (dB)	Result (dB μ V/m)	Limit (dB μ V/m)	Margin (dB)	Remark
1	0.203	101.43	-16.88	84.55	101.45	-16.90	Peak
2	0.562	65.35	-16.90	48.45	72.60	-24.15	Peak
3	0.691	64.94	-16.79	48.15	70.80	-22.65	Peak
4	1.281	57.95	-16.82	41.13	65.40	-24.27	Peak

- NOTES:
1. Peak Detector Data unless otherwise stated.
 2. All measurements were made at 3 meters. Harmonic emissions not detected at the 3-meter distances were measured at 0.3-meter and an inverse proportional extrapolation was performed to compare the signal level to the 3-meter limit. No other harmonic emissions than those reported were detected at a test distance of 0.3-meter.
 3. Negative sign in the column shows value below limit.
 4. Loop antenna is used for the emissions below 30MHz.
 5. Measurement Uncertainty is ± 5.3 dB at a level of confidence of 95%.
 6. 5W / 10W was considered in the test, only worst case was shown on the test report.

TEST REPORT

RADIATED EMISSIONS

Model: LJSL-MV-IRN

Date of Test: October 24, 2019 to November 04, 2019

Worst-Case Operating Mode: Operating with Max. Power Output

Table 2
Pursuant to FCC Part 15 Section 15.209 Requirement

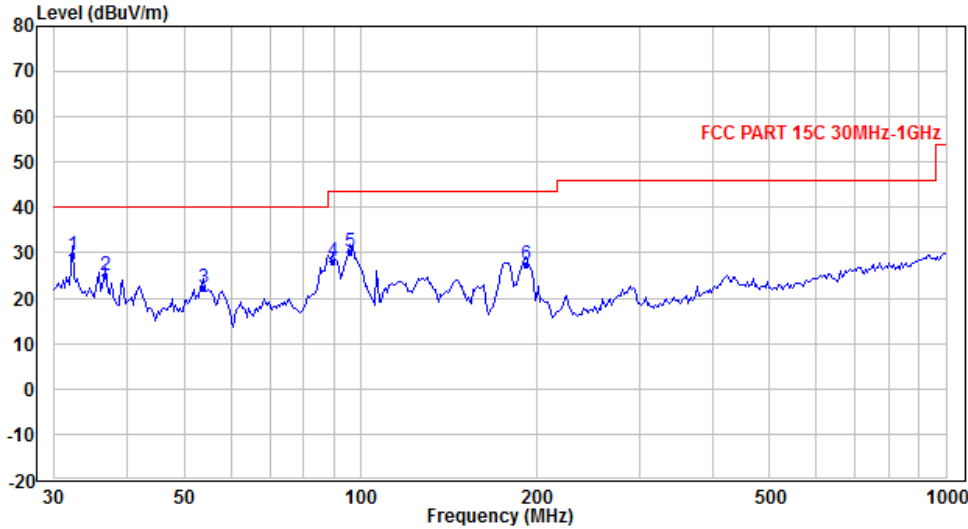

No.	Frequency (MHz)	Reading (dBµV/m)	Correction factor (dB)	Result (dBµV/m)	Limit (dBµV/m)	Margin (dB)	Remark
1	32.184	35.14	-5.54	29.60	40.00	-10.40	Peak
2	36.524	33.55	-8.67	24.88	40.00	-15.12	Peak
3	53.756	35.90	-13.73	22.17	40.00	-17.83	Peak
4	89.787	40.60	-12.65	27.95	43.50	-15.55	Peak
5	95.649	41.98	-11.96	30.02	43.50	-13.48	Peak
6	191.784	37.36	-10.11	27.25	43.50	-16.25	Peak

- NOTES:
1. Peak Detector Data unless otherwise stated.
 2. All measurements were made at 3 meters. Harmonic emissions not detected at the 3-meter distances were measured at 0.3-meter and an inverse proportional extrapolation was performed to compare the signal level to the 3-meter limit. No other harmonic emissions than those reported were detected at a test distance of 0.3-meter.
 3. Negative sign in the column shows value below limit.
 4. Loop antenna is used for the emissions below 30MHz.
 5. Measurement Uncertainty is ± 5.3 dB at a level of confidence of 95%.
 6. 5W / 10W was considered in the test, only worst case was shown on the test report.

TEST REPORT

RADIATED EMISSIONS

Model: LJSL-MV-IRN

Date of Test: October 24, 2019 to November 04, 2019

Worst-Case Operating Mode: Operating with Max. Power Output

Table 3
Pursuant to FCC Part 15 Section 15.209 Requirement

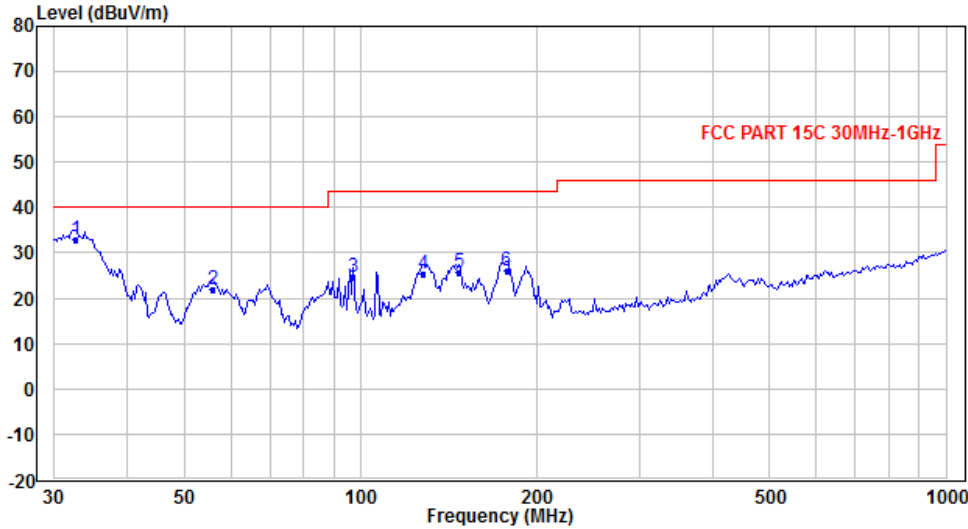

No.	Frequency (MHz)	Reading (dB μ V/m)	Correction factor (dB)	Result (dB μ V/m)	Limit (dB μ V/m)	Margin (dB)	Remark
1	32.640	38.86	-5.94	32.92	40.00	-7.08	Peak
2	56.071	36.00	-14.07	21.93	40.00	-18.07	Peak
3	97.002	36.63	-11.85	24.78	43.50	-18.72	Peak
4	127.586	36.96	-11.59	25.37	43.50	-18.13	Peak
5	146.839	36.68	-11.12	25.56	43.50	-17.94	Peak
6	177.518	36.20	-10.17	26.03	43.50	-17.47	Peak

- NOTES:
1. Peak Detector Data unless otherwise stated.
 2. All measurements were made at 3 meters. Harmonic emissions not detected at the 3-meter distances were measured at 0.3-meter and an inverse proportional extrapolation was performed to compare the signal level to the 3-meter limit. No other harmonic emissions than those reported were detected at a test distance of 0.3-meter.
 3. Negative sign in the column shows value below limit.
 4. Loop antenna is used for the emissions below 30MHz.
 5. Measurement Uncertainty is ± 5.3 dB at a level of confidence of 95%.
 6. 5W / 10W was considered in the test, only worst case was shown on the test report.

TEST REPORT

4.0 EQUIPMENT PHOTOGRAPHS

For electronic filing, the photographs are saved with filename: external photos.pdf and internal photos.pdf.

5.0 PRODUCT LABELLING

For electronics filing, the FCC ID label artwork and the label location are saved with filename: label.pdf.

6.0 TECHNICAL SPECIFICATIONS

For electronic filing, the block diagram and schematic of the tested EUT are saved with filename: block.pdf and circuit.pdf respectively.

7.0 INSTRUCTION MANUAL

For electronic filing, a preliminary copy of the Instruction Manual is saved with filename: manual.pdf.

This manual will be provided to the end-user with each unit sold/leased in the United States.

TEST REPORT

8.0 MISCELLANEOUS INFORMATION

The miscellaneous information includes details of the test procedure and measured bandwidth / calculation of factor such as pulse desensitization and averaging factor (calculation and timing diagram).

8.1 Measured Bandwidth

Pursuant to FCC Part 15 Section 15.215(c), the 20dB bandwidth of the emission was contained within the frequency band designed (mentioned as above) which the EUT operated. The effects, if any, from frequency sweeping, frequency hopping, other modulation techniques and frequency stability over expected variations in temperature and supply voltage were considered.

8.2 Discussion of Pulse Desensitization

Pulse desensitivity is not applicable for this device. Since the transmitter transmits the RF signal continuously.

8.3 Calculation of Average Factor

The average factor is not applicable for this device as the transmitted signal is a continuously signal.

TEST REPORT

8.4 Emissions Test Procedures

The following is a description of the test procedure used by Intertek Testing Services Hong Kong Ltd. in the measurements of transmitter operating under the Part 15, Subpart C rules.

The transmitting equipment under test (EUT) is placed on a wooden turntable which is four feet in diameter and approximately 0.8m in height above the ground plane for emission measurement at or below 1GHz and 1.5m in height above the ground plane for emission measurement above 1GHz. During the radiated emissions test, the turntable is rotated and any cables leaving the EUT are manipulated to find the configuration resulting in maximum emissions. The EUT is adjusted through all three orthogonal axis to obtain maximum emission levels. The antenna height and polarization are also varied during the testing to search for maximum signal levels. The height of the antenna is varied from one to four meters.

Detector function for radiated emissions is in peak mode. Average readings, when required, are taken by measuring the duty cycle of the equipment under test and subtracting the corresponding amount in dB from the measured peak readings. A detailed description for the calculation of the average factor can be found in Exhibit 8.3.

The frequency range scanned is from the lowest radio frequency signal generated in the device which is greater than 9 kHz to the tenth harmonic of the highest fundamental frequency or 40 GHz, whichever is lower. For line conducted emissions, the range scanned is 150 kHz to 30 MHz.

TEST REPORT

8.4 Emissions Test Procedures (cont'd)

The EUT is warmed up for 15 minutes prior to the test.

AC power to the unit is varied from 85% to 115% nominal and variation in the fundamental emission field strength is recorded. If battery powered, a new, fully charged battery is used.

Conducted measurements were made as described in ANSI C63.10 (2013).

The IF bandwidth used for measurement of radiated signal strength was 100 kHz or greater when frequency is below 1000 MHz. Where pulsed transmissions of short enough pulse duration warrant, a greater bandwidth is selected according to the recommendations of Hewlett Packard Application Note 150-2. A discussion of whether pulse desensitvity is applicable to this unit is included in this report (See Exhibit 8.1). Above 1000 MHz, a resolution bandwidth of 3 MHz is used.

Transmitter measurements are normally conducted at a measurement distance of three meters. However, to assure low enough noise floor in the forbidden bands and above 1 GHz, signals are acquired at a distance of one meter or less. All measurements are extrapolated to three meters using inverse scaling, unless otherwise reported. Measurements taken at a closer distance are so marked.

TEST REPORT

8.4.1 Radiated Emission Test Setup

The figure below shows the test setup, which is utilized to make these measurements.

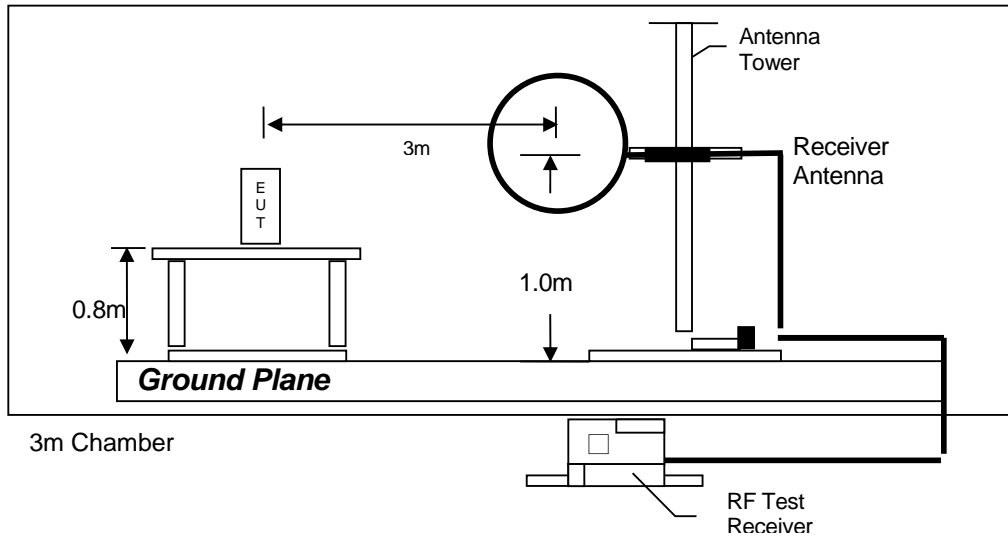

Test setup of radiated emissions up to 30MHz

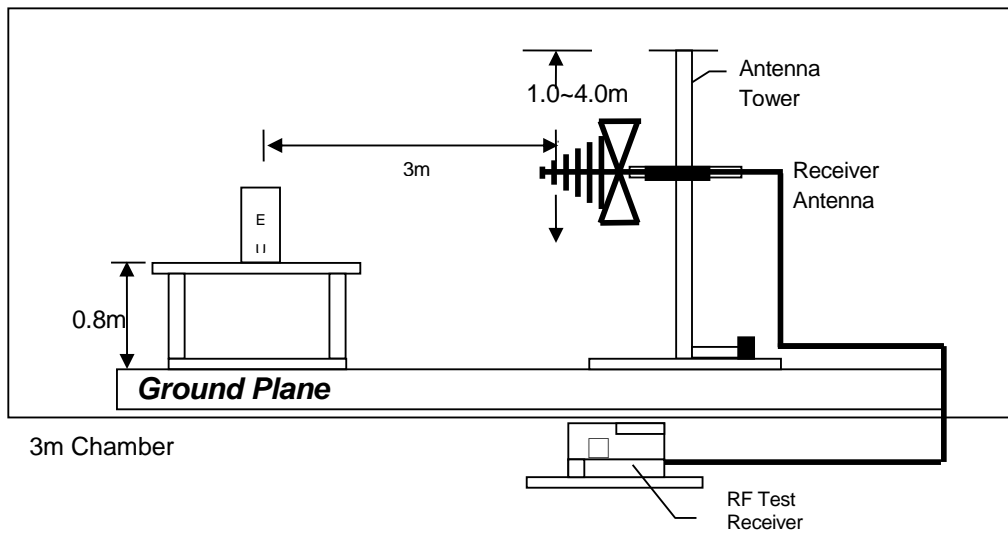

Test setup of radiated emissions above 1GHz

TEST REPORT

8.4.2 Conducted Emission Test Procedures

For tabletop equipment, the EUT along with its peripherals were placed on a 1.0m(W)×1.5m(L) and 0.8m in height wooden table. For floor-standing equipment, the EUT and all cables were insulated, if required, from the ground plane by up to 12 mm of insulating material. The EUT was adjusted to maintain a 0.4 meter space from a vertical reference plane. The EUT was connected to power mains through a line impedance stabilization network (LISN), which provided 50 ohm coupling impedance for measuring instrument and the chassis ground was bounded to the horizontal ground plane of shielded room. The excess power cable between the EUT and the LISN was bundled.

All connecting cables of EUT and peripherals were moved to find the maximum emission.

8.4.3 Conducted Emission Test Setup

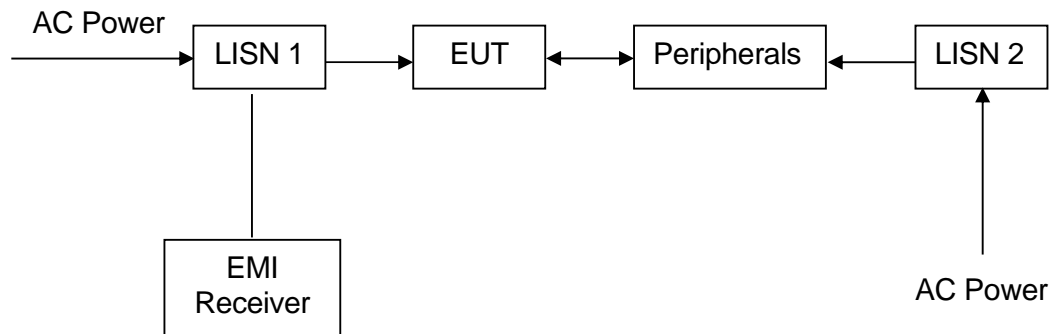

TEST REPORT

9.0 CONFIDENTIALITY REQUEST

For electronic filing, a preliminary copy of the confidentiality request is saved with filename: request.pdf.

10.0 EQUIPMENT LIST

1) Radiated Emissions Test

Equipment	3M Chamber & Accessory Equipment	Receiver	Loop Antenna
Registration No.	UTTL—E010	UTTL—E026	UTTL—E013
Manufacturer	ETS-LINDGREN	R&S	ETS-LINDGREN
Model No.	3M	ESIB26	6502
Calibration Date	December 03, 2018	November 24, 2018	December 03, 2018
Calibration Due Date	December 03, 2021	November 24, 2019	December 03, 2019

Equipment	Broadband Antenna	6dB Attenuator	Preamplifier
Registration No.	UTTL—E014	UTTL—E056	UTTL—E043
Manufacturer	ETS-LINDGREN	Talent	HP
Model No.	3142E	RA6A5-N-18	8447F
Calibration Date	December 08, 2018	December 08, 2018	November 24, 2018
Calibration Due Date	December 08, 2019	December 08, 2019	November 24, 2019

2) Conducted Emissions Test

Equipment	Receiver	Pulse Limiter	LISN
Registration No.	UTTL—E005	UTTL—E007	UTTL—E003
Manufacturer	R&S	R&S	R&S
Model No.	ESR7	ESH3-Z2	ESH2-Z5
Calibration Date	November 24, 2018	November 24, 2018	November 24, 2018
Calibration Due Date	November 24, 2019	November 24, 2019	November 24, 2019

END OF TEST REPORT