

TEST REPORT

ACCORDING TO: FCC part 27, part 15 subpart B

FOR:

Arcadian Networks

Wireless modem

Model:V487i

This report is in conformity with ISO/ IEC 17025. The "A2LA Accredited" symbol endorsement applies only to the tests and calibrations that are listed in the scope of Hermon Laboratories accreditation. The test results relate only to the items tested.
This test report shall not be reproduced in any form except in full with the written approval of Hermon Laboratories Ltd.



Table of contents

1	Applicant information.....	3
2	Equipment under test attributes	3
3	Manufacturer information	3
4	Test details.....	3
5	Tests summary.....	4
6	EUT description.....	5
6.1	General information.....	5
6.2	Ports and lines	5
6.3	Support and test equipment	5
6.4	Operating frequencies	5
6.5	Changes made in the EUT	5
6.6	Test configuration.....	6
6.7	Transmitter characteristics	7
7	Transmitter characteristics	8
7.1	Peak output power test.....	8
7.2	Spurious emissions at RF antenna connector test.....	10
7.3	Spurious emissions at RF antenna connector test in 763-775 MHz and 793 – 805 MHz.....	24
7.4	Radiated spurious emission measurements.....	30
7.5	Radiated spurious emission measurements in 1559-1610 MHz band	44
7.6	Frequency stability test.....	49
7.7	Occupied bandwidth test.....	56
8	Emissions tests according to 47CFR part 15 subpart B requirements	60
8.1	Conducted emissions	60
8.2	Radiated emission measurements	65
8.3	Antenna power conducted measurements for receiver	71
9	APPENDIX A Test equipment and ancillaries used for tests.....	74
10	APPENDIX B Measurement uncertainties.....	76
11	APPENDIX C Test laboratory description	77
12	APPENDIX D Specification references	77
13	APPENDIX E Test equipment correction factors.....	78
14	APPENDIX F Abbreviations and acronyms.....	90

1 Applicant information

Client name: Arcadian Networks Inc.
Address: 400 Columbus Avenue, Suite 210E, Valhalla, NY 10595, USA
Telephone: +972 3976 9847
Fax: +972 3976 9998
E-mail: hillel.hendler@arcadiannetworks.com
Contact name: Mr. Hillel Hendler

2 Equipment under test attributes

Product name: Wireless modem
Operating frequency range: 787.1625 – 787.8375 MHz
Model: V487i
Receipt date: 11/19/2007

3 Manufacturer information

Manufacturer name: Arcadian Networks Inc.
Address: 400 Columbus Avenue, Suite 210E, Valhalla, NY 10595, USA
Telephone: +972 3976 9847
Fax: +972 3976 9998
E-Mail: Arnon.afgin@arcadiannetworks.com
Contact name: Mr. Arnon Afgin

4 Test details



Project ID: 18308
Location: Hermon Laboratories Ltd. P.O.Box 23, Binyamina 30500, Israel
Test started: 11/19/2007
Test completed: 12/31/2007
Test specifications: FCC part 27:2007; FCC part 15: 2007 subpart B

5 Tests summary

Test	Status
Transmitter characteristics	
Section 27.50(b)(9), Peak output power at RF antenna connector	Pass
Section 2.1091, 27.52, RF safety	Pass, an exhibit provided in Application for certification
Section 27.53(c)(2), Spurious emissions RF antenna connector	Pass
Section 27.53(c)(3), Spurious emissions RF antenna connector in 763-775MHz and 793-805 MHz	Pass
Section 27.53(c)(2), Radiated spurious emissions	Pass
Section 27.53(f), Radiated spurious emissions in 1559-1610 MHz band	Pass
Section 27.54, Frequency stability	Pass
Section 2.1049, Occupied bandwidth	Pass
Unintentional emissions	
Section 15.107, Conducted emission at AC power port, class A	Pass
Section 15.109, Radiated emission, class A	Pass
Section 15.111, Antenna power conducted measurements for receiver	Pass

The test results relate only to the items tested. Pass / fail decision was based on nominal values.

This test report replaces the previously issued test report identified by Doc ID:ARCRAD_FCC.18308_rev1.

	Name and Title	Date	Signature
Tested by:	Mr. S. Samokha, test engineer	December 31, 2007	
Reviewed by:	Mrs. M. Cherniavsky, certification engineer	January 22, 2008	
Approved by:	Mr. M. Nikishin, EMC and Radio group leader	April 16, 2008	

6 EUT description

6.1 General information

The EUT is a broadband wireless data modem used by cable and wireless operators to deliver data services and high-speed data connections to business and residential subscribers. The EUT operates within 787 to 788 MHz band and is powered from AC mains through a customer power adaptor.

6.2 Ports and lines

Port type	Port description	Connected		Connector type	Qty.	Cable type	Cable length	Indoor / outdoor
		From	To					
Power	AC mains	Power supply	AC mains	IEC 60320	1	Unshielded	1.5 m	Indoor
Power	DC	EUT	Power supply	DC jack	1	Unshielded	1.5 m	Indoor
Signal	Antenna	EUT	Attenuator	F-type	1	Coax 75 Ohm	5.0 m	Outdoor
Power	AC mains	Power adaptor	AC mains	IEC 60320	1	Unshielded	1.5 m	Indoor
Power	DC	Laptop	Power adaptor	DC jack	1	Unshielded	1.5 m	Indoor

6.3 Support and test equipment

Description	Manufacturer	Model number	Serial number
Wireless modem termination system	Vyyo	V3000	0094417
Up converter	Wavecom	UC4040D	216447
Down converter	Vyyo	V3100-A	9VY0003-3
Combiner (two-way splitter)	RMS	NA	NA
Laptop	IBM	ThinkPad 600x	5573MWV
Power adaptor for laptop	IBM	02K6654	3892A299
Switch Hub	Tricom	3300	0602/7ZPV4949
Power supply for EUT	Nemic Lambda	UP36-12	2634
Power adaptor for Down converter	Deer Computers	AD1607B	NA

6.4 Operating frequencies

Source	Frequency, MHz	
Crystals	16.11	24.11
Rx	757	758
VTCXO	13	
Local oscillator	743.5	

6.5 Changes made in the EUT

No changes were implemented.

6.6 Test configuration

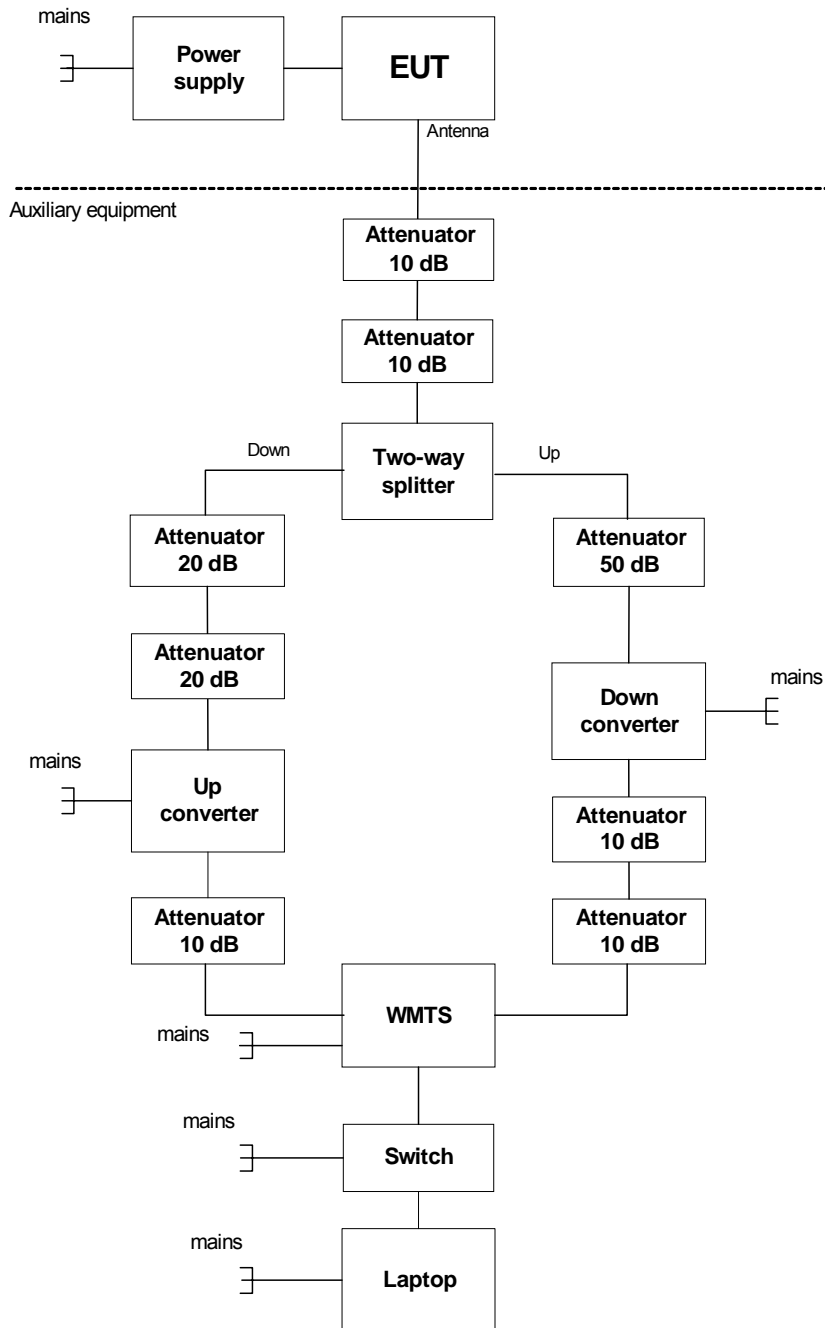



6.7 Transmitter characteristics

Type of equipment						
	Stand-alone (Equipment with or without its own control provisions)					
X	Combined equipment (Equipment where the radio part is fully integrated within another type of equipment)					
	Plug-in card (Equipment intended for a variety of host systems)					
Intended use		Condition of use				
X	fixed	Always at a distance more than 2 m from all people				
	mobile	Always at a distance more than 20 cm from all people				
	portable	May operate at a distance closer than 20 cm to human body				
Assigned frequency range		787.0 – 788.0 MHz				
Operating frequency range		787.1625 – 787.8375 MHz				
Maximum rated output power		At transmitter 50 Ω RF output connector			33 dBm	
		Effective radiated power (for equipment with no RF connector)			NA	
Is transmitter output power variable?		No				
		continuous variable				
		X	Yes	Stepped variable with stepsize		1 dB
				minimum RF power		-17.0 dBm
		maximum RF power		33 dBm		
Antenna connection						
unique coupling	X	standard F-type connector	integral	with temporary RF connector		
				without temporary RF connector		
Antenna/s technical characteristics						
Type	Manufacturer	Model number	Gain			
Yagi	Skymast	4RF0054-A	11.5 dBd			
Transmitter 99% power bandwidth		325 kHz				
Type of multiplexing		TDMA				
Modulating test signal (baseband)		PRBS				
Maximum transmitter duty cycle in normal use		50 %				
Transmitter duty cycle supplied for test		50 %				
Transmitter power source						
	Battery	Nominal rated voltage	VDC	Battery type		
	DC	Nominal rated voltage	VDC			
X	AC mains	Nominal rated voltage	120 VAC	Frequency	60 Hz	
Common power source for transmitter and receiver			X	yes	no	
Type of modulation	Modulation states (constellation)	RF channel spacing	Frequency channel			
			Low	Mid	High	
QAM	16	325 kHz	787.1625	787.5	787.8375	
QPSK	4	325 kHz	787.1625	787.5	787.8375	

Test specification:	Section 27.50(b)(9), Peak output power at RF antenna connector		
Test procedure:	47 CFR, Section 2.1046; TIA/EIA-603-C, Section 2.2.1		
Test mode:	Compliance	Verdict:	PASS
Date:	12/03/2007		
Temperature: 22 °C	Air Pressure: 1012 hPa	Relative Humidity: 45 %	Power Supply: 120 VAC
Remarks:			

7 Transmitter characteristics

7.1 Peak output power test

7.1.1 General

This test was performed to measure the peak output power at RF antenna connector. Specification test limits are given in Table 7.1.1.

Table 7.1.1 Peak output power limits

Assigned frequency range, MHz	Maximum peak output power*	
	dBm	W
787.0 – 788.0	44.77	30.0

* The peak output power limit was calculated by subtracting of antenna gain in dBd from maximum allowed ERP 44.77 dBm (30 W):

$$44.77 \text{ dBm} - (13.65 \text{ dBi} - 2.15 \text{ dB}) = 33.27 \text{ dBm}$$

7.1.2 Test procedure for measurements with power meter

7.1.2.1 The EUT was set up as shown in Figure 7.1.1, energized and its proper operation was checked.

7.1.2.2 The EUT was adjusted to produce maximum available to the end user RF output power.

7.1.2.3 The peak output power was measured with thermocouple power meter as provided in Table 7.1.2 and associated plots.

Figure 7.1.1 Peak output power test setup

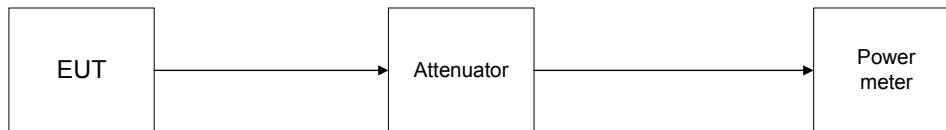



Test specification:	Section 27.50(b)(9), Peak output power at RF antenna connector		
Test procedure:	47 CFR, Section 2.1046; TIA/EIA-603-C, Section 2.2.1		
Test mode:	Compliance	Verdict:	PASS
Date:	12/03/2007		
Temperature: 22 °C	Air Pressure: 1012 hPa	Relative Humidity: 45 %	Power Supply: 120 VAC
Remarks:			

Table 7.1.2 Conducted output power test results

ASSIGNED FREQUENCY RANGE: 787.0 – 788.0 MHz
DETECTOR USED: Peak
MODULATING SIGNAL: PRBS
TRANSMITTER OUTPUT POWER SETTINGS: Maximum

Carrier frequency, MHz	Spectrum analyzer reading, dBm	External attenuation, dB	Cable loss, dB	RF output power, dBm	Limit, dBm	Margin, dB	Verdict
Modulation: 16QAM (Rx gain 10)							
787.1625	33.07	Included		33.07	33.27	-0.20	Pass
787.5000	33.02	Included		33.02	33.27	-0.25	Pass
787.8375	33.04	Included		33.04	33.27	-0.23	Pass
Modulation: QPSK (Rx gain 30)							
787.1625	33.02	Included		33.02	33.27	-0.25	Pass
787.5000	33.03	Included		33.03	33.27	-0.24	Pass
787.8375	33.04	Included		33.04	33.27	-0.23	Pass

ASSIGNED FREQUENCY RANGE: 787.0 – 788.0 MHz
DETECTOR USED: Average
MODULATING SIGNAL: PRBS
TRANSMITTER OUTPUT POWER SETTINGS: Maximum

Carrier frequency, MHz	Spectrum analyzer reading, dBm	External attenuation, dB	Cable loss, dB	RF output power, dBm	Limit, dBm	Margin, dB	Verdict
Modulation: 16QAM (Rx gain 10)							
787.1625	25.56	Included		25.56	33.27	-7.71	Pass
787.5000	25.76	Included		25.76	33.27	-7.51	Pass
787.8375	24.47	Included		24.47	33.27	-8.80	Pass
Modulation: QPSK (Rx gain 30)							
787.1625	30.12	Included		30.12	33.27	-3.15	Pass
787.5000	30.25	Included		30.25	33.27	-3.02	Pass
787.8375	30.16	Included		30.16	33.27	-3.11	Pass

Reference numbers of test equipment used

HL 2011	HL 2867	HL 2869	HL 3175	HL 3180	HL 3301	HL 3334	
---------	---------	---------	---------	---------	---------	---------	--

Full description is given in Appendix A.

Test specification:	Section 27.53(c)(2), Spurious emissions at RF antenna connector		
Test procedure:	47 CFR, Sections 2.1047, 2.1051, TIA/EIA-603-C, Section 2.2.13		
Test mode:	Compliance	Verdict:	PASS
Date:	11/27/2007		
Temperature: 23 °C	Air Pressure: 1013 hPa	Relative Humidity: 45 %	Power Supply: 120 VAC
Remarks:			

7.2 Spurious emissions at RF antenna connector test

7.2.1 General

This test was performed to measure spurious emissions at RF antenna connector. Specification test limits are given in Table 7.2.1.

Table 7.2.1 Spurious emission limits

Frequency, MHz*	Attenuation below carrier, dBc	Spurious emissions, dBm
0.009 – 10 th harmonic	43+10logP*	-13

* - P is transmitter output power in Watts.

7.2.2 Test procedure

7.2.2.1 The EUT was set up as shown in Figure 7.2.1, energized and its proper operation was checked.

7.2.2.2 The EUT was adjusted to produce maximum available for end user RF output power.

7.2.2.3 The spurious emission was measured with spectrum analyzer as provided in Table 7.2.2 and associated plots.

Figure 7.2.1 Spurious emission test setup

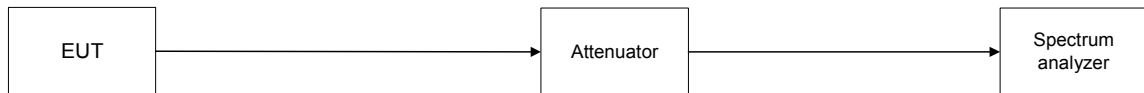



Test specification:	Section 27.53(c)(2), Spurious emissions at RF antenna connector		
Test procedure:	47 CFR, Sections 2.1047, 2.1051, TIA/EIA-603-C, Section 2.2.13		
Test mode:	Compliance	Verdict:	PASS
Date:	11/27/2007		
Temperature: 23 °C	Air Pressure: 1013 hPa	Relative Humidity: 45 %	Power Supply: 120 VAC
Remarks:			

Table 7.2.2 Spurious emission test results

ASSIGNED FREQUENCY RANGE: 787.0 – 788.0 MHz
 INVESTIGATED FREQUENCY RANGE: 0.009 – 8000 MHz
 DETECTOR USED: Peak
 VIDEO BANDWIDTH: ≥ Resolution bandwidth
 TRANSMITTER OUTPUT POWER SETTINGS: Maximum
 MODULATING SIGNAL: PRBS

MODULATION: QPSK

Frequency, MHz	Bit rate, Mbps	RBW, kHz	Spurious emission, dBm	Limit, dBm	Margin, dB*	Verdict
Low channel						
0.009 - 8000			More than 20 dB below the specified limit			Pass
High channel						
0.009 - 8000			More than 20 dB below the specified limit			Pass

*- Margin = Spurious emission – specification limit.

MODULATION: 16QAM

Frequency, MHz	Bit rate, Mbps	RBW, kHz	Spurious emission, dBm	Limit, dBm	Margin, dB*	Verdict
Low channel						
0.009 - 8000			More than 20 dB below the specified limit			Pass
High channel						
0.009 - 8000			More than 20 dB below the specified limit			Pass

Reference numbers of test equipment used

HL 1424	HL 2011	HL 2867	HL 2869	HL 3175	HL 3180	HL 3334	HL 3340
---------	---------	---------	---------	---------	---------	---------	---------

Full description is given in Appendix A.



Test specification:	Section 27.53(c)(2), Spurious emissions at RF antenna connector		
Test procedure:	47 CFR, Sections 2.1047, 2.1051, TIA/EIA-603-C, Section 2.2.13		
Test mode:	Compliance	Verdict:	PASS
Date:	11/27/2007		
Temperature: 23 °C	Air Pressure: 1013 hPa	Relative Humidity: 45 %	Power Supply: 120 VAC
Remarks:			

Plot 7.2.1 Spurious emission measurements at RF antenna connector, low channel

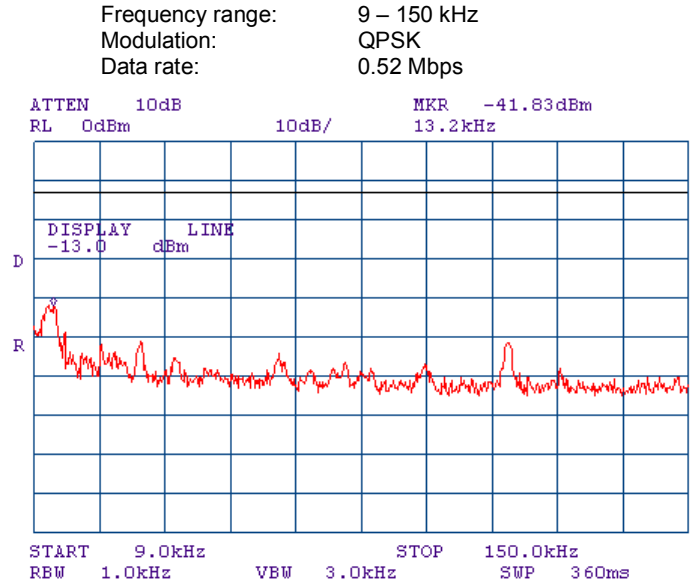

Plot 7.2.2 Spurious emission measurements at RF antenna connector, low channel

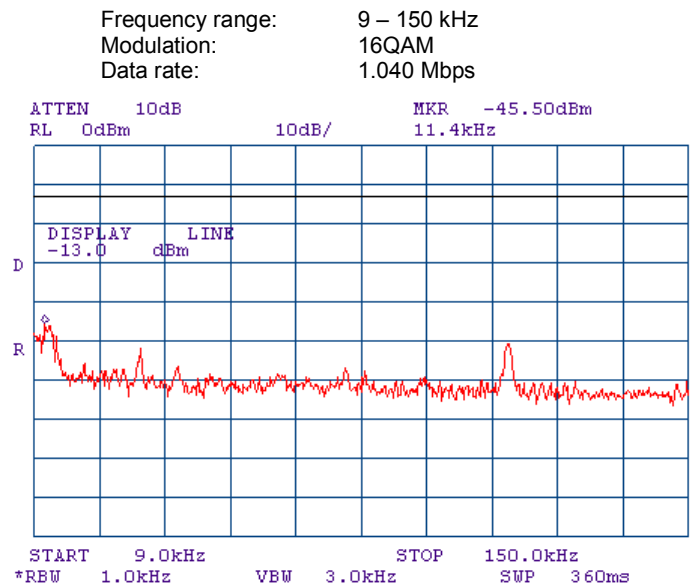

Test specification:	Section 27.53(c)(2), Spurious emissions at RF antenna connector		
Test procedure:	47 CFR, Sections 2.1047, 2.1051, TIA/EIA-603-C, Section 2.2.13		
Test mode:	Compliance	Verdict:	PASS
Date:	11/27/2007		
Temperature: 23 °C	Air Pressure: 1013 hPa	Relative Humidity: 45 %	Power Supply: 120 VAC
Remarks:			

Plot 7.2.3 Spurious emission measurements at RF antenna connector, high channel

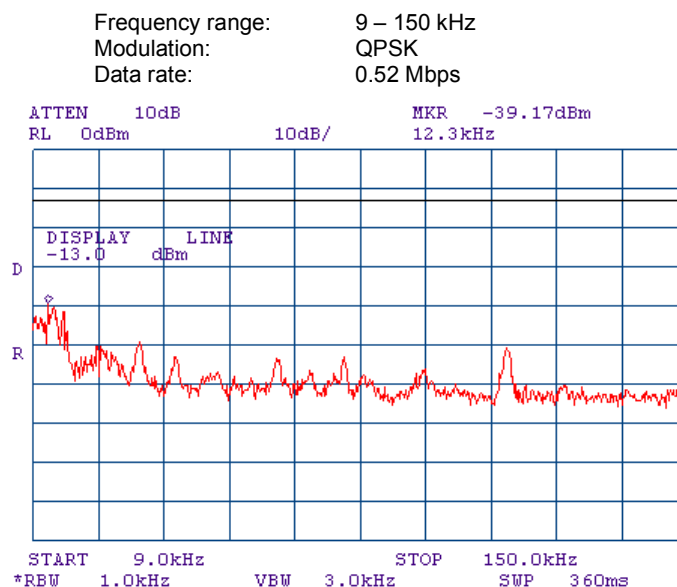

Plot 7.2.4 Spurious emission measurements at RF antenna connector, high channel

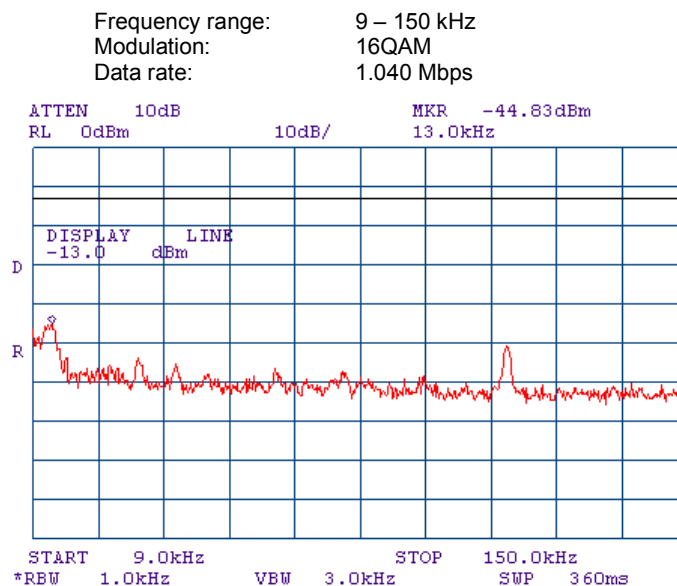

Test specification:	Section 27.53(c)(2), Spurious emissions at RF antenna connector		
Test procedure:	47 CFR, Sections 2.1047, 2.1051, TIA/EIA-603-C, Section 2.2.13		
Test mode:	Compliance	Verdict:	PASS
Date:	11/27/2007		
Temperature: 23 °C	Air Pressure: 1013 hPa	Relative Humidity: 45 %	Power Supply: 120 VAC
Remarks:			

Plot 7.2.5 Spurious emission measurements at RF antenna connector, low channel

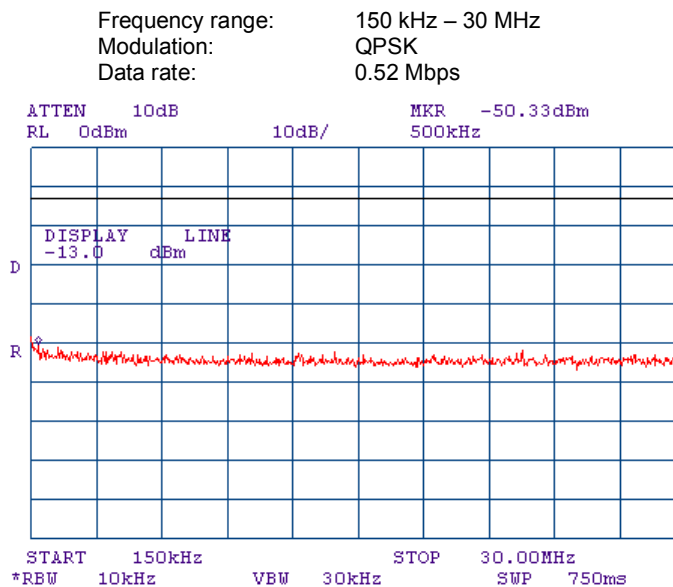

Plot 7.2.6 Spurious emission measurements at RF antenna connector, low channel

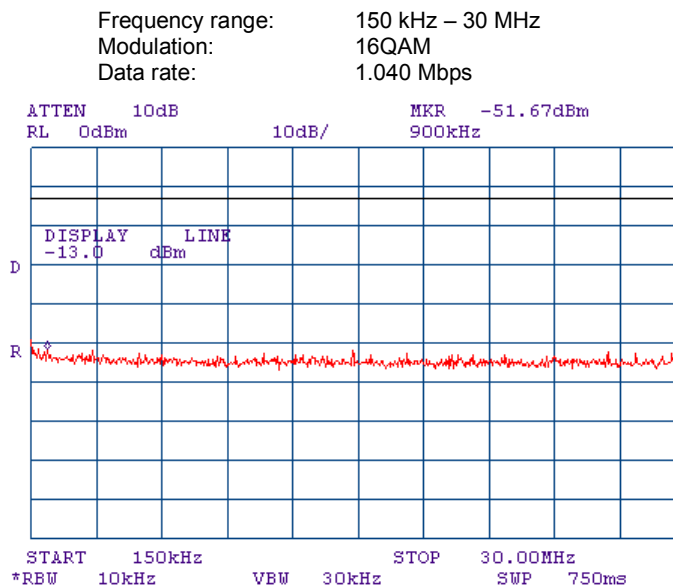



Test specification:	Section 27.53(c)(2), Spurious emissions at RF antenna connector		
Test procedure:	47 CFR, Sections 2.1047, 2.1051, TIA/EIA-603-C, Section 2.2.13		
Test mode:	Compliance	Verdict:	PASS
Date:	11/27/2007		
Temperature: 23 °C	Air Pressure: 1013 hPa	Relative Humidity: 45 %	Power Supply: 120 VAC
Remarks:			

Plot 7.2.7 Spurious emission measurements at RF antenna connector, high channel

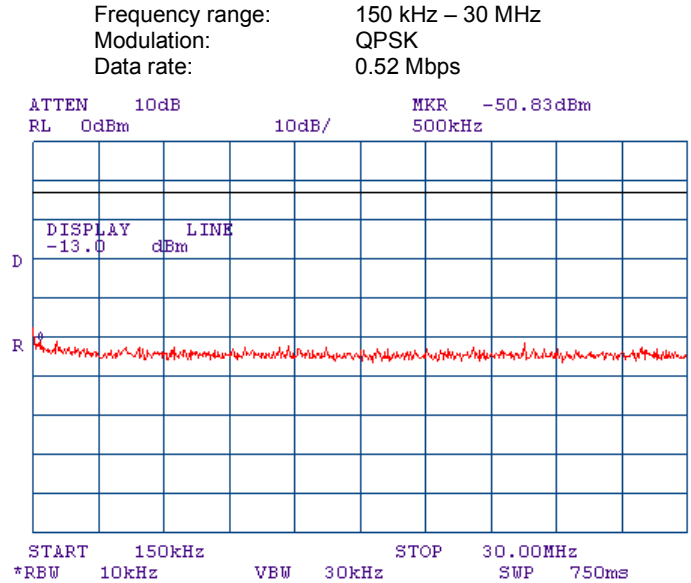

Plot 7.2.8 Spurious emission measurements at RF antenna connector, high channel

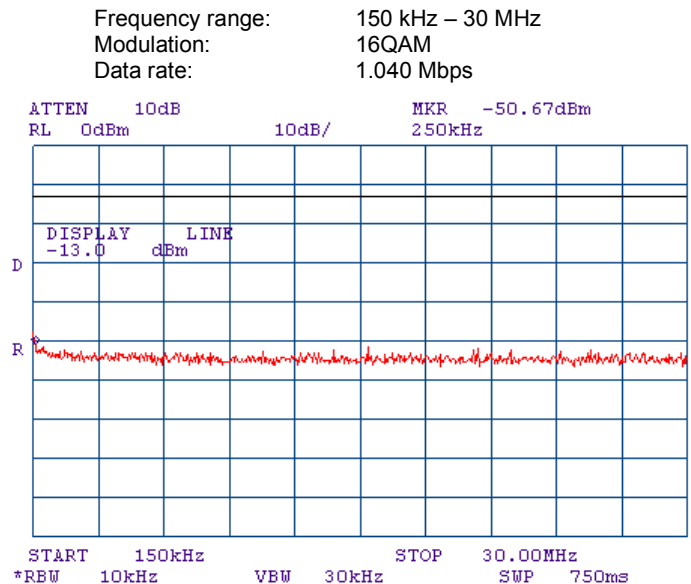

Test specification:	Section 27.53(c)(2), Spurious emissions at RF antenna connector		
Test procedure:	47 CFR, Sections 2.1047, 2.1051, TIA/EIA-603-C, Section 2.2.13		
Test mode:	Compliance	Verdict:	PASS
Date:	11/27/2007		
Temperature: 23 °C	Air Pressure: 1013 hPa	Relative Humidity: 45 %	Power Supply: 120 VAC
Remarks:			

Plot 7.2.9 Spurious emission measurements at RF antenna connector, low channel

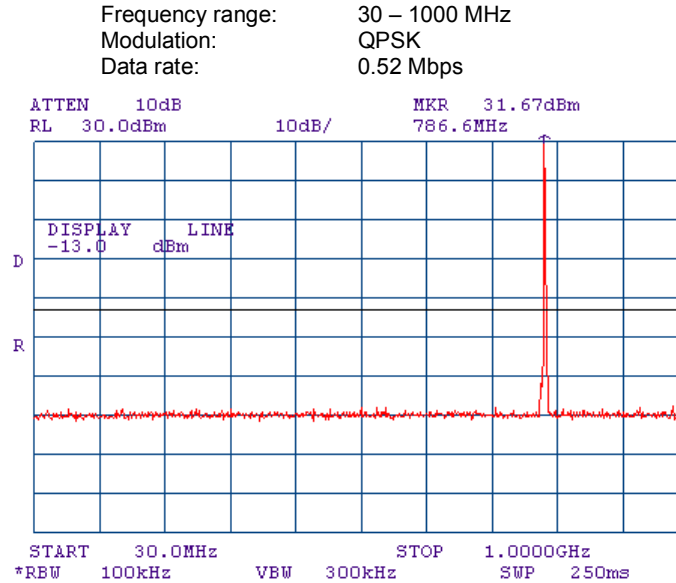

Plot 7.2.10 Spurious emission measurements at RF antenna connector, low channel

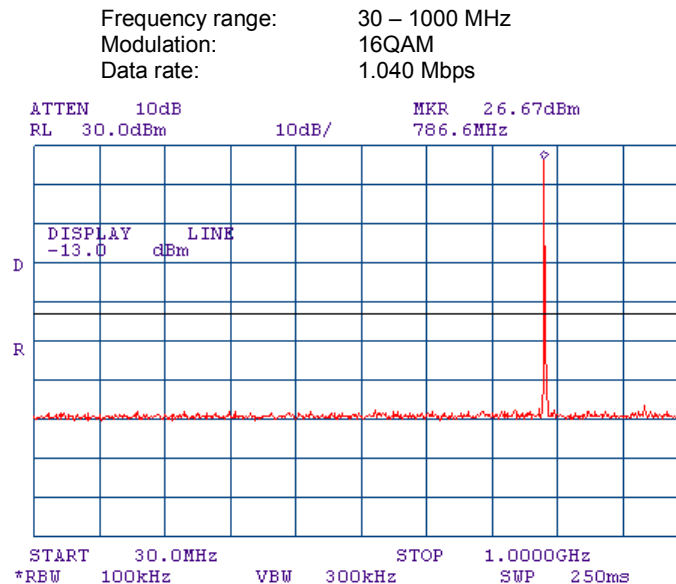

Test specification:	Section 27.53(c)(2), Spurious emissions at RF antenna connector		
Test procedure:	47 CFR, Sections 2.1047, 2.1051, TIA/EIA-603-C, Section 2.2.13		
Test mode:	Compliance	Verdict:	PASS
Date:	11/27/2007		
Temperature: 23 °C	Air Pressure: 1013 hPa	Relative Humidity: 45 %	Power Supply: 120 VAC
Remarks:			

Plot 7.2.11 Spurious emission measurements at RF antenna connector, high channel

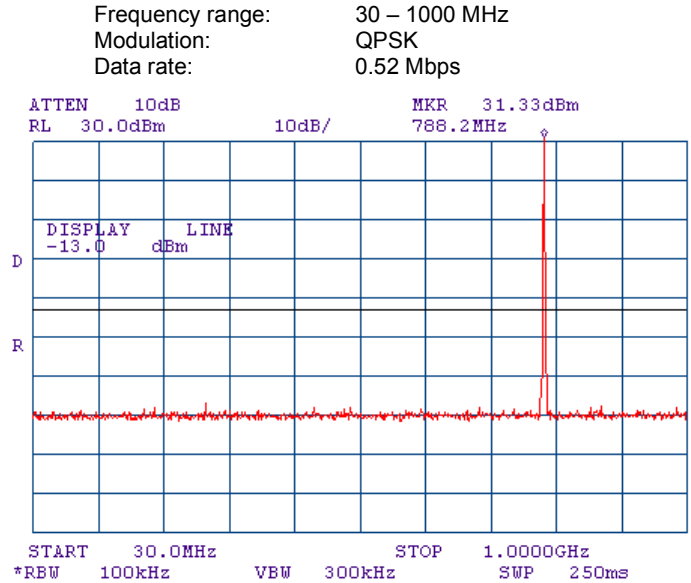

Plot 7.2.12 Spurious emission measurements at RF antenna connector, high channel

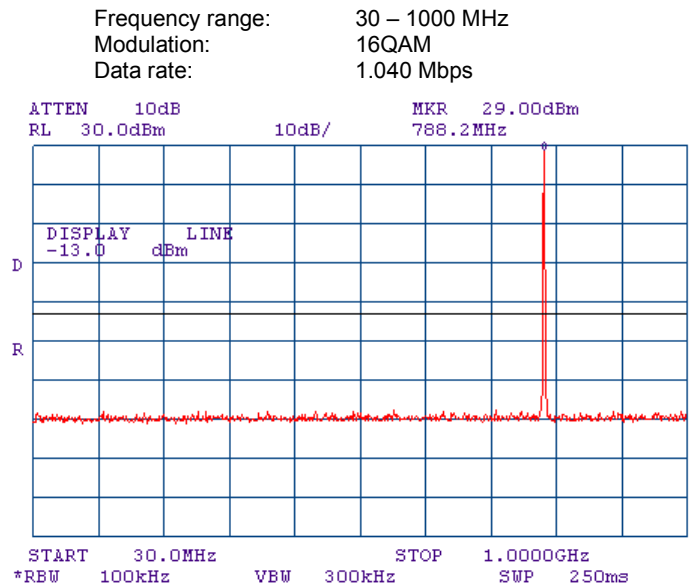



Test specification:	Section 27.53(c)(2), Spurious emissions at RF antenna connector		
Test procedure:	47 CFR, Sections 2.1047, 2.1051, TIA/EIA-603-C, Section 2.2.13		
Test mode:	Compliance	Verdict:	PASS
Date:	11/27/2007		
Temperature: 23 °C	Air Pressure: 1013 hPa	Relative Humidity: 45 %	Power Supply: 120 VAC
Remarks:			

Plot 7.2.13 Spurious emission measurements at RF antenna connector, low channel

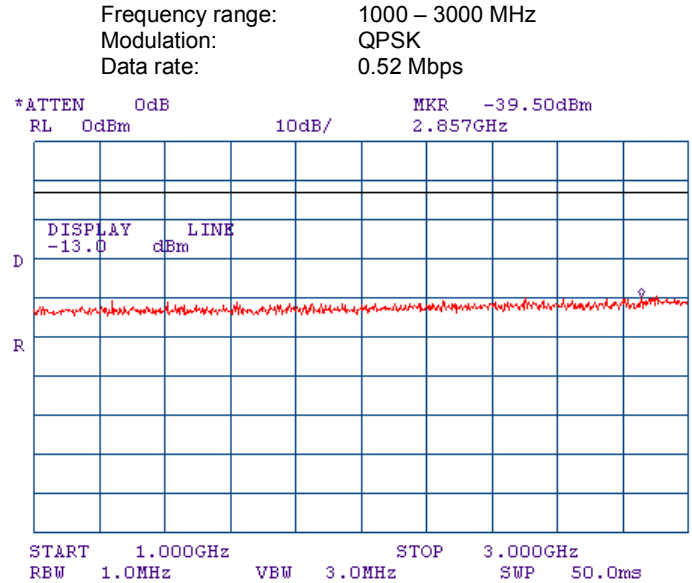

Plot 7.2.14 Spurious emission measurements at RF antenna connector, low channel

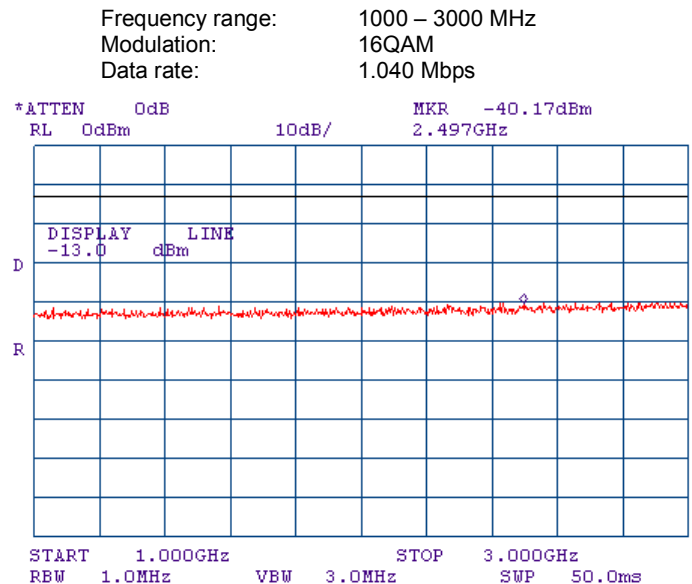



Test specification:	Section 27.53(c)(2), Spurious emissions at RF antenna connector		
Test procedure:	47 CFR, Sections 2.1047, 2.1051, TIA/EIA-603-C, Section 2.2.13		
Test mode:	Compliance	Verdict:	PASS
Date:	11/27/2007		
Temperature: 23 °C	Air Pressure: 1013 hPa	Relative Humidity: 45 %	Power Supply: 120 VAC
Remarks:			

Plot 7.2.15 Spurious emission measurements at RF antenna connector, high channel

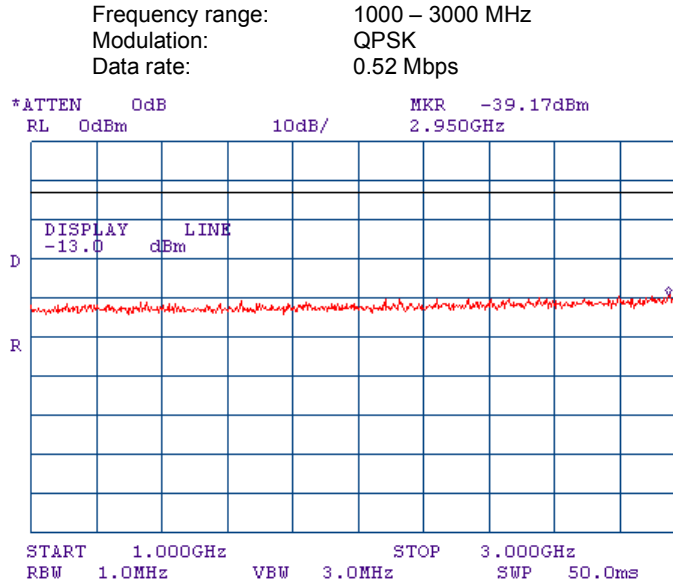

Plot 7.2.16 Spurious emission measurements at RF antenna connector, high channel

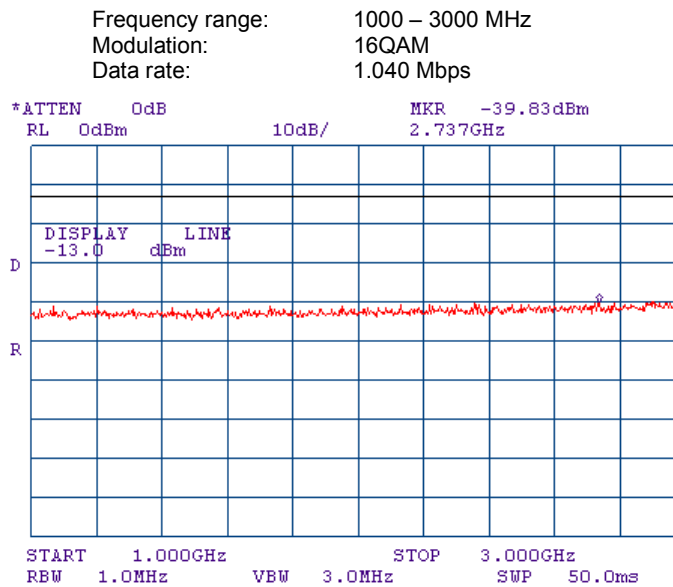



Test specification:	Section 27.53(c)(2), Spurious emissions at RF antenna connector		
Test procedure:	47 CFR, Sections 2.1047, 2.1051, TIA/EIA-603-C, Section 2.2.13		
Test mode:	Compliance	Verdict:	PASS
Date:	11/27/2007		
Temperature: 23 °C	Air Pressure: 1013 hPa	Relative Humidity: 45 %	Power Supply: 120 VAC
Remarks:			

Plot 7.2.17 Spurious emission measurements at RF antenna connector, low channel

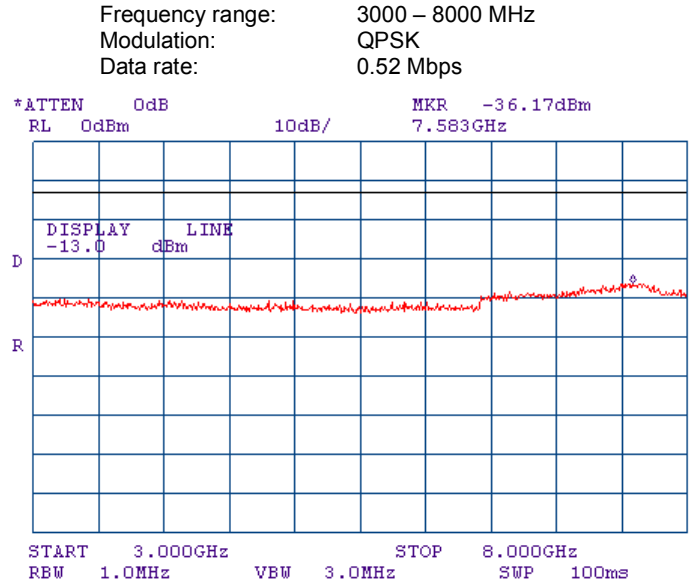

Plot 7.2.18 Spurious emission measurements at RF antenna connector, low channel

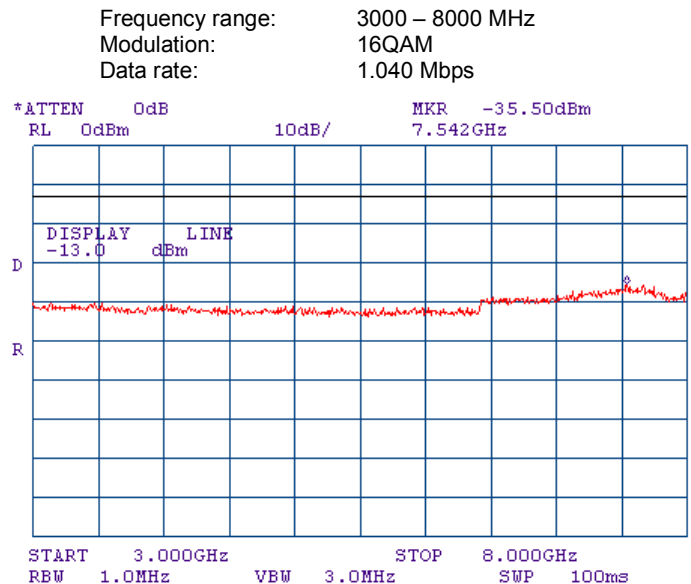



Test specification:	Section 27.53(c)(2), Spurious emissions at RF antenna connector		
Test procedure:	47 CFR, Sections 2.1047, 2.1051, TIA/EIA-603-C, Section 2.2.13		
Test mode:	Compliance	Verdict:	PASS
Date:	11/27/2007		
Temperature: 23 °C	Air Pressure: 1013 hPa	Relative Humidity: 45 %	Power Supply: 120 VAC
Remarks:			

Plot 7.2.19 Spurious emission measurements at RF antenna connector, high channel

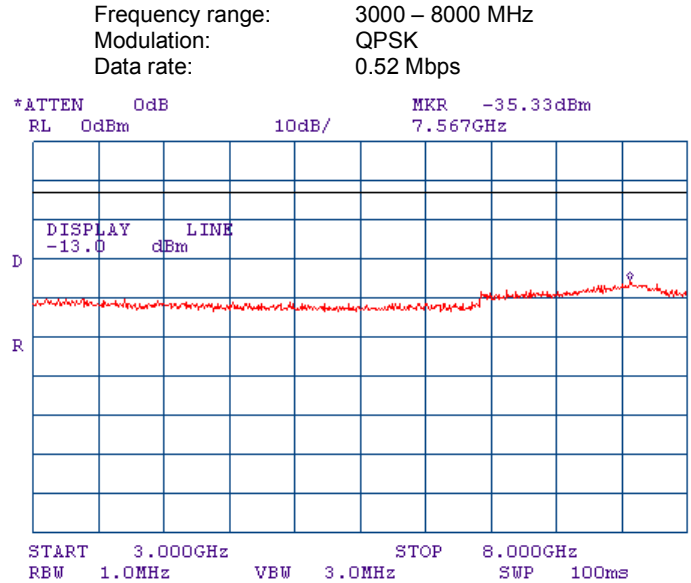

Plot 7.2.20 Spurious emission measurements at RF antenna connector, high channel

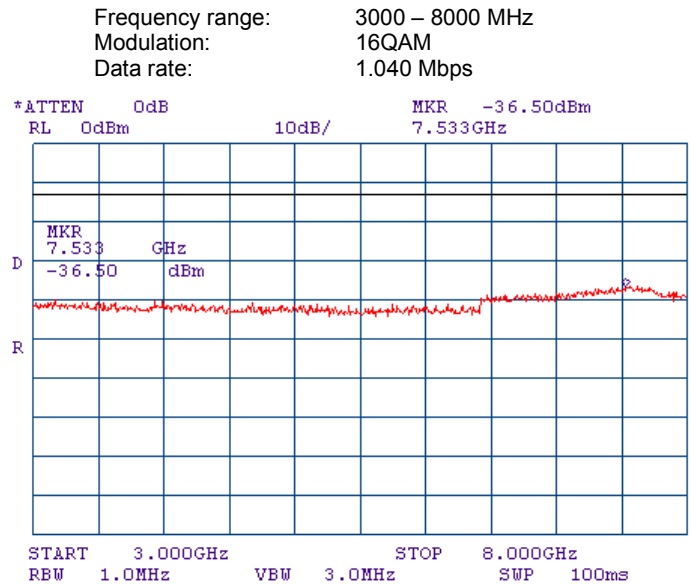



Test specification:	Section 27.53(c)(2), Spurious emissions at RF antenna connector		
Test procedure:	47 CFR, Sections 2.1047, 2.1051, TIA/EIA-603-C, Section 2.2.13		
Test mode:	Compliance	Verdict:	PASS
Date:	11/27/2007		
Temperature: 23 °C	Air Pressure: 1013 hPa	Relative Humidity: 45 %	Power Supply: 120 VAC
Remarks:			

Plot 7.2.21 Spurious emissions at RF antenna connector, low channel band edge measurements

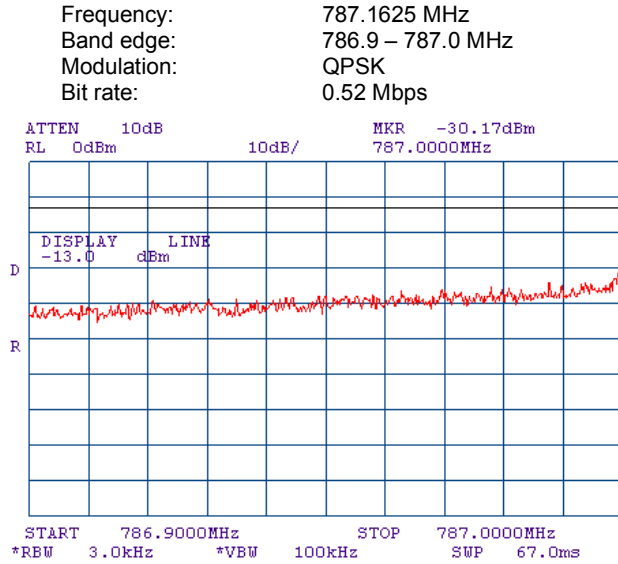

Test result = SA reading + Correction factor = -30.17 dBm + 10 dB = -20.17 dBm
Correction factor = $10 \cdot \log(30\text{kHz}/3\text{kHz}) = 10 \text{ dB}$

Plot 7.2.22 Spurious emissions at RF antenna connector, high channel band edge measurements

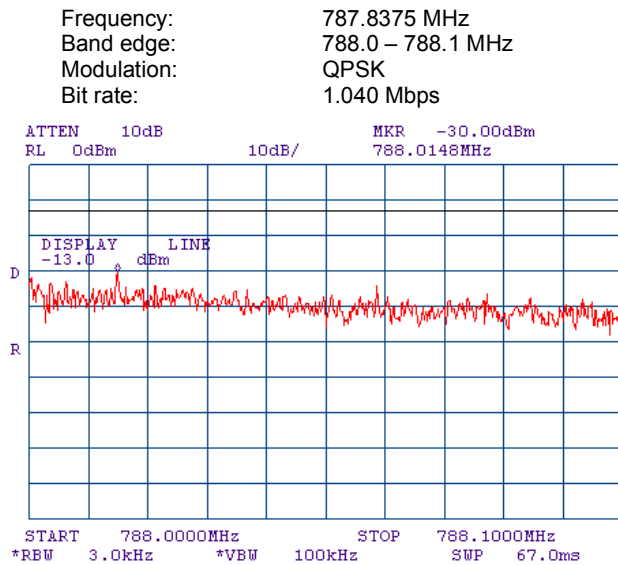

Test result = SA reading + Correction factor = -30.0 dBm + 10 dB = -20.0 dBm
Correction factor = $10 \cdot \log(30\text{kHz}/3\text{kHz}) = 10 \text{ dB}$



Test specification:	Section 27.53(c)(2), Spurious emissions at RF antenna connector		
Test procedure:	47 CFR, Sections 2.1047, 2.1051, TIA/EIA-603-C, Section 2.2.13		
Test mode:	Compliance	Verdict:	PASS
Date:	11/27/2007		
Temperature: 23 °C	Air Pressure: 1013 hPa	Relative Humidity: 45 %	Power Supply: 120 VAC
Remarks:			

Plot 7.2.23 Spurious emissions at RF antenna connector, low channel band edge measurements

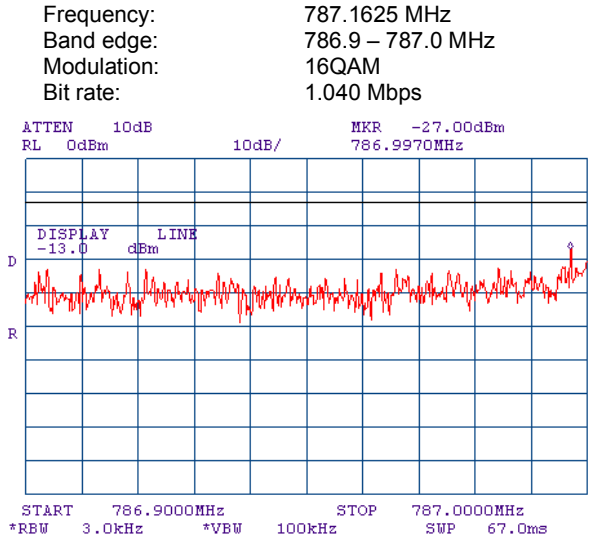

Test result = SA reading + Correction factor = -27.0 dBm + 10 dB = -17.0 dBm
Correction factor = $10 \cdot \log(30\text{kHz}/3\text{kHz}) = 10 \text{ dB}$

Plot 7.2.24 Spurious emissions at RF antenna connector, high channel band edge measurements

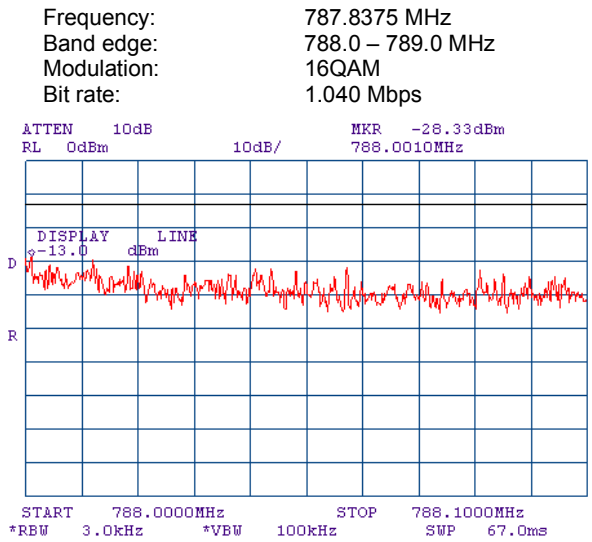

Test result = SA reading + Correction factor = -28.39 dBm + 10 dB = -18.39 dBm
Correction factor = $10 \cdot \log(30\text{kHz}/3\text{kHz}) = 10 \text{ dB}$

Test specification:	Section 27.53(c)(3), Spurious emissions at RF antenna connector in 763-775 MHz and 793 – 805 MHz		
Test procedure:	47 CFR, Sections 2.1047, 2.1051, TIA/EIA-603-C, Section 2.2.13		
Test mode:	Compliance	Verdict:	PASS
Date:	12/31/2007		
Temperature: 22 °C	Air Pressure: 1017 hPa	Relative Humidity: 42 %	Power Supply: 120 VAC
Remarks:			

7.3 Spurious emissions at RF antenna connector test in 763-775 MHz and 793 – 805 MHz

7.3.1 General

This test was performed to measure spurious emissions at RF antenna connector. Specification test limits are given in Table 7.3.1.

Table 7.3.1 Spurious emission limits

Frequency, MHz*	Attenuation below carrier, dBc	Spurious emissions, dBm
763 – 775 MHz	76+10logP*	-46
793 – 805 MHz	76+10logP*	-46

* - P is transmitter output power in Watts.

7.3.2 Test procedure

7.3.2.1 The EUT was set up as shown in Figure 7.3.1, energized and its proper operation was checked.

7.3.2.2 The EUT was adjusted to produce maximum available for end user RF output power.

7.3.2.3 The spurious emission was measured with spectrum analyzer as provided in Table 7.3.2 and associated plots.

Figure 7.3.1 Occupied bandwidth test setup

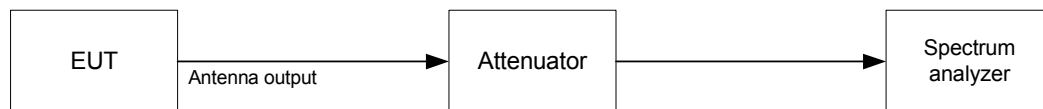



Test specification:	Section 27.53(c)(3), Spurious emissions at RF antenna connector in 763-775 MHz and 793 – 805 MHz		
Test procedure:	47 CFR, Sections 2.1047, 2.1051, TIA/EIA-603-C, Section 2.2.13		
Test mode:	Compliance	Verdict:	PASS
Date:	12/31/2007		
Temperature: 22 °C	Air Pressure: 1017 hPa	Relative Humidity: 42 %	Power Supply: 120 VAC
Remarks:			

Table 7.3.2 Spurious emission test results

ASSIGNED FREQUENCY RANGE: 787.0 – 788.0 MHz
 INVESTIGATED FREQUENCY RANGE: 763 – 775 MHz, 793 – 805 MHz
 DETECTOR USED: Peak
 VIDEO BANDWIDTH: ≥ Resolution bandwidth

MODULATING SIGNAL: PRBS
 TRANSMITTER OUTPUT POWER SETTINGS: Maximum

MODULATION: QPSK

Frequency, MHz	Bit rate, Mbps	RBW, kHz	Spurious emission, dBm	Limit, dBm	Margin, dB*	Verdict
Low channel						
763 – 775	0.52	10	-56.97	-46.00	-10.97	Pass
793 - 805	0.52	10	-51.60	-46.00	-5.60	Pass
High channel						
763 – 775	0.52	10	-57.22	-46.00	-11.22	Pass
793 - 805	0.52	10	-48.24	-46.00	-2.24	Pass

MODULATION: 16QAM

Frequency, MHz	Bit rate, Mbps	RBW, kHz	Spurious emission, dBm	Limit, dBm	Margin, dB*	Verdict
Low channel						
763 – 775	1.040	10	-56.89	-46.00	-10.89	Pass
793 - 805	1.040	10	-50.40	-46.00	-4.40	Pass
High channel						
763 – 775	1.040	10	-57.23	-46.00	-11.23	Pass
793 - 805	1.040	10	-50.25	-46.00	-4.25	Pass

*- Margin = Spurious emission – specification limit.

Reference numbers of test equipment used

HL 2011	HL 2867	HL 2869	HL 2909	HL 3175	HL 3180		
---------	---------	---------	---------	---------	---------	--	--

Full description is given in Appendix A.



Test specification:	Section 27.53(c)(3), Spurious emissions at RF antenna connector in 763-775 MHz and 793 – 805 MHz		
Test procedure:	47 CFR, Sections 2.1047, 2.1051, TIA/EIA-603-C, Section 2.2.13		
Test mode:	Compliance	Verdict:	PASS
Date:	12/31/2007		
Temperature: 22 °C	Air Pressure: 1017 hPa	Relative Humidity: 42 %	Power Supply: 120 VAC
Remarks:			

Plot 7.3.1 Spurious emission test results at low frequency

Frequency range 763 – 775 MHz
Bit rate: 0.52 Mbps
Modulation: QPSK

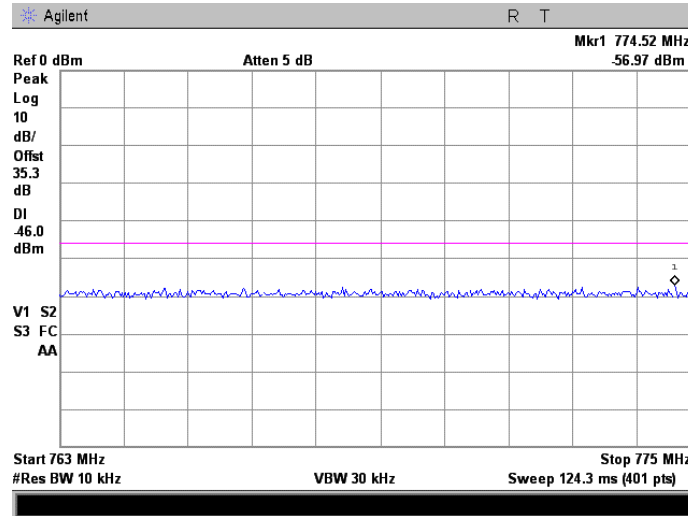

Plot 7.3.2 Spurious emission test results at low frequency

Frequency range 793 – 805 MHz
Bit rate: 0.52 Mbps
Modulation: QPSK

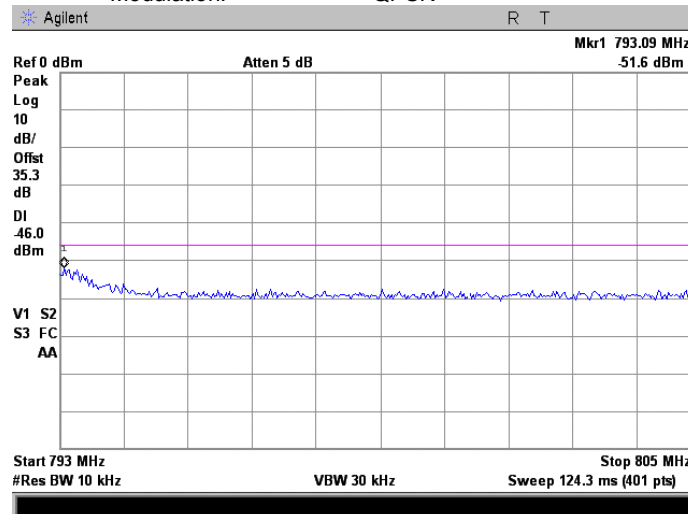



Test specification:	Section 27.53(c)(3), Spurious emissions at RF antenna connector in 763-775 MHz and 793 – 805 MHz		
Test procedure:	47 CFR, Sections 2.1047, 2.1051, TIA/EIA-603-C, Section 2.2.13		
Test mode:	Compliance	Verdict:	PASS
Date:	12/31/2007		
Temperature: 22 °C	Air Pressure: 1017 hPa	Relative Humidity: 42 %	Power Supply: 120 VAC
Remarks:			

Plot 7.3.3 Spurious emission test results at high frequency

Frequency range 763 – 775 MHz
Bit rate: 0.52 Mbps
Modulation: QPSK

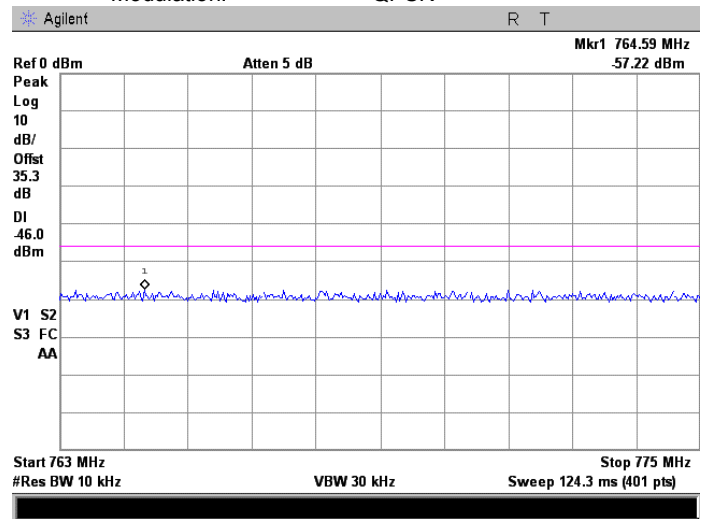

Plot 7.3.4 Spurious emission test results at high frequency

Frequency range 793 – 805 MHz
Bit rate: 0.52 Mbps
Modulation: QPSK

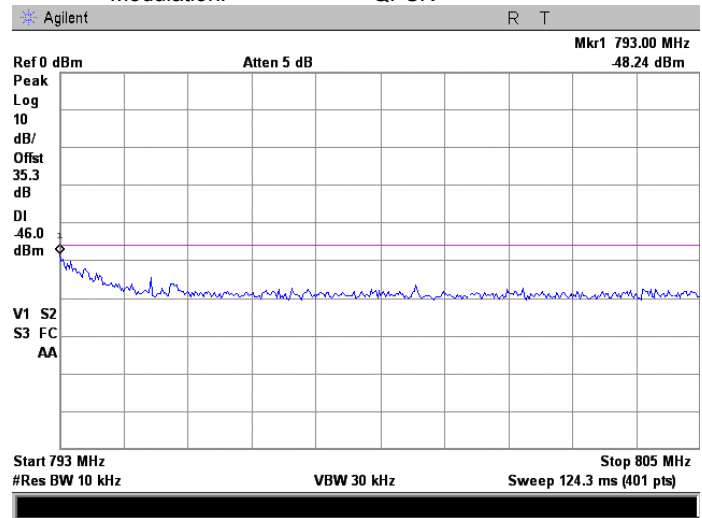

Test specification:	Section 27.53(c)(3), Spurious emissions at RF antenna connector in 763-775 MHz and 793 – 805 MHz		
Test procedure:	47 CFR, Sections 2.1047, 2.1051, TIA/EIA-603-C, Section 2.2.13		
Test mode:	Compliance	Verdict:	PASS
Date:	12/31/2007		
Temperature: 22 °C	Air Pressure: 1017 hPa	Relative Humidity: 42 %	Power Supply: 120 VAC
Remarks:			

Plot 7.3.5 Spurious emission test results at low frequency

Frequency range 763 – 775 MHz
Bit rate: 1.040 Mbps
Modulation: 16 QAM

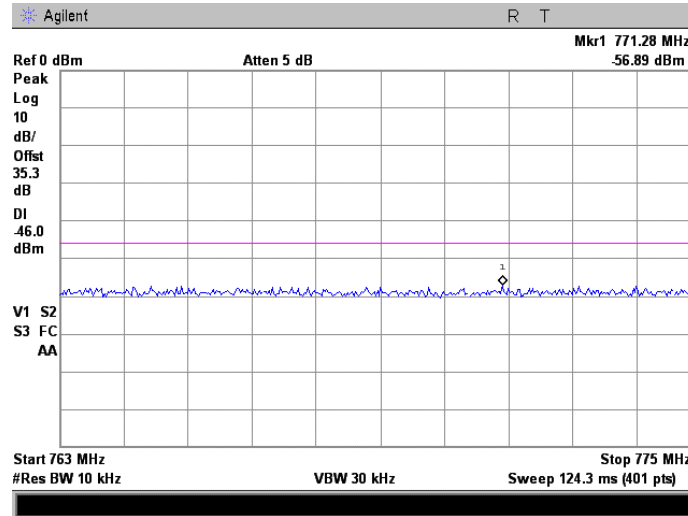

Plot 7.3.6 Spurious emission test results at low frequency

Frequency range 793 – 805 MHz
Bit rate: 1.040 Mbps
Modulation: 16 QAM

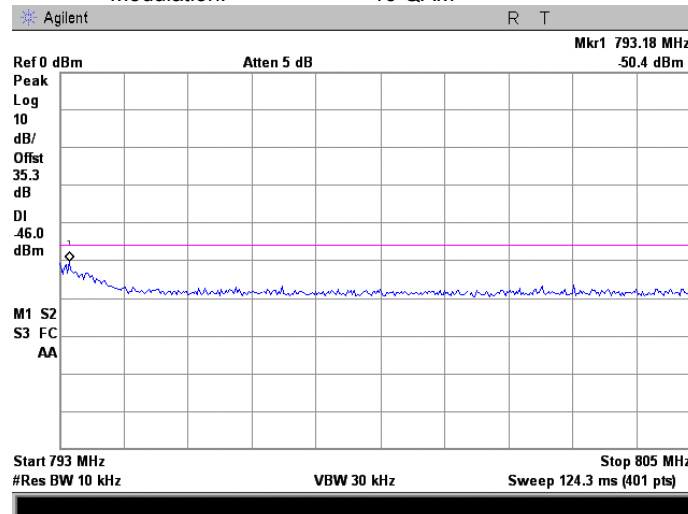



Test specification:	Section 27.53(c)(3), Spurious emissions at RF antenna connector in 763-775 MHz and 793 – 805 MHz		
Test procedure:	47 CFR, Sections 2.1047, 2.1051, TIA/EIA-603-C, Section 2.2.13		
Test mode:	Compliance	Verdict:	PASS
Date:	12/31/2007		
Temperature: 22 °C	Air Pressure: 1017 hPa	Relative Humidity: 42 %	Power Supply: 120 VAC
Remarks:			

Plot 7.3.7 Spurious emission test results at high frequency

Frequency range 763 – 775 MHz
 Bit rate: 1.040 Mbps
 Modulation: 16 QAM

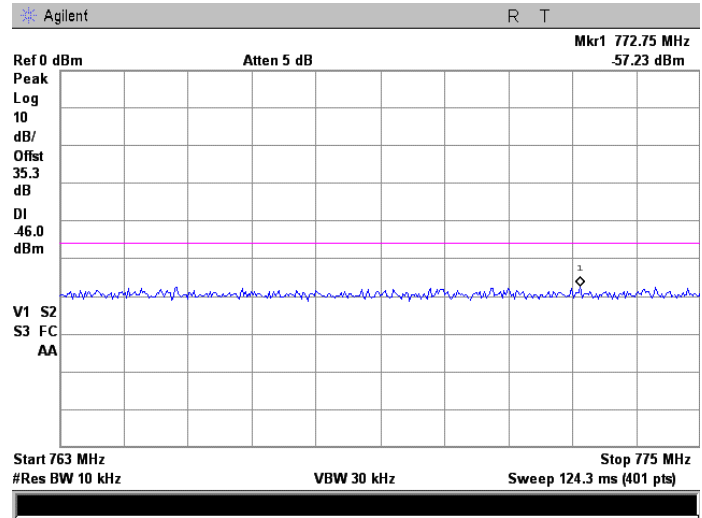

Plot 7.3.8 Spurious emission test results at high frequency

Frequency range 793 – 805 MHz
 Bit rate: 1.040 Mbps
 Modulation: 16 QAM

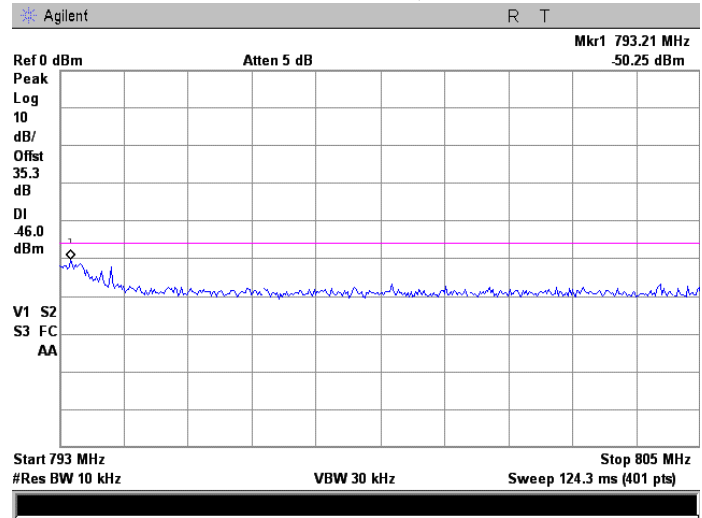

Test specification:	Section 27.53(c)(2), Radiated spurious emissions		
Test procedure:	47 CFR, Section 2.1053, TIA/EIA-603-C, Section 2.2.12		
Test mode:	Compliance	Verdict:	PASS
Date:	11/22/2007		
Temperature: 24 °C	Air Pressure: 1016 hPa	Relative Humidity: 45 %	Power Supply: 120 VAC
Remarks:			

7.4 Radiated spurious emission measurements

7.4.1 General

This test was performed to measure radiated spurious emissions from the EUT enclosure with antenna connector terminated with 50 Ohm dummy load. Specification test limits are given in Table 7.4.1.

Table 7.4.1 Radiated spurious emission test limits

Frequency, MHz*	Attenuation below carrier dBc	Spurious emissions, dBm	Equivalent field strength limit @ 3m, dB(μV/m)**
0.009 – 10 th harmonic	43+10logP*	-13	84.4

* - P is transmitter output power in Watts.

** - Equivalent field strength limit was calculated from maximum allowed ERP of spurious as follows:
 $E = \sqrt{(30 \times P \times 1.64) / r}$, where P is ERP in Watts, 1.64 is numeric gain of ideal dipole and r is antenna to EUT distance in meters.

7.4.2 Test procedure for spurious emission field strength measurements in 9 kHz to 30 MHz range

7.4.2.1 The EUT was set up as shown in Figure 7.4.1, energized and the EUT performance was checked.

7.4.2.2 The specified frequency range was investigated with antenna connected to spectrum analyzer. To find maximum radiation the turntable was rotated 360° and the measuring antenna was rotated around its vertical axis.

7.4.2.3 The test results were recorded in Table 7.4.2 and shown in the associated plots.

7.4.3 Test procedure for spurious emission field strength measurements above 30 MHz

7.4.3.1 The EUT was set up as shown in Figures 7.5.2, energized and the EUT performance was checked.

7.4.3.2 The specified frequency range was investigated with antennas connected to spectrum analyzer. To find maximum radiation the turntable was rotated 360° and the measuring antenna height was swept from 1 to 4 m in both, vertical and horizontal, polarizations.

7.4.3.3 The worst test results with respect to the limits were recorded in Table 7.4.2 and shown in the associated plots.

7.4.4 Test procedure for substitution ERP measurements of spurious

7.4.4.1 The test equipment was set up as shown in Figure 7.4.3 and energized.

7.4.4.2 RF signal generator was set to the frequency of investigated spurious emission and the RF output level was preliminary adjusted to produce the same field strength as it was measured from the EUT.

7.4.4.3 The test antenna height was swept from 1 to 4 m to find maximum emission from substitution antenna and RF signal generator output was fine adjusted to produce the same field strength as it was measured from the EUT.

7.4.4.4 The above procedure was performed in both, horizontal and vertical, polarizations of the test and substitution antennas.

7.4.4.5 The EIRP of spurious emissions was calculated as a sum of signal generator output power in dBm and antenna gain in dBd reduced by cable loss in dB.

7.4.4.6 The above procedure was repeated at the rest of investigated frequencies.

7.4.4.7 The worst test results (the lowest margins) were recorded in Table 7.4.3 and shown in the associated plots.

Test specification:	Section 27.53(c)(2), Radiated spurious emissions		
Test procedure:	47 CFR, Section 2.1053, TIA/EIA-603-C, Section 2.2.12		
Test mode:	Compliance	Verdict:	PASS
Date:	11/22/2007		
Temperature: 24 °C	Air Pressure: 1016 hPa	Relative Humidity: 45 %	Power Supply: 120 VAC
Remarks:			

Figure 7.4.1 Setup for spurious emission field strength measurements in 9 kHz to 30 MHz range

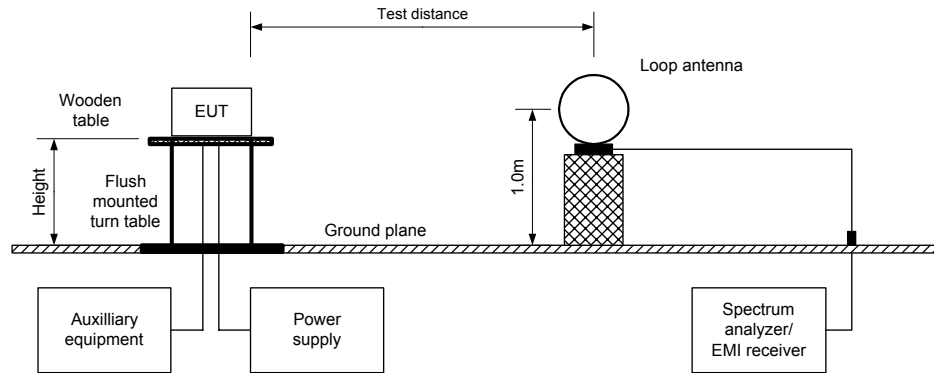
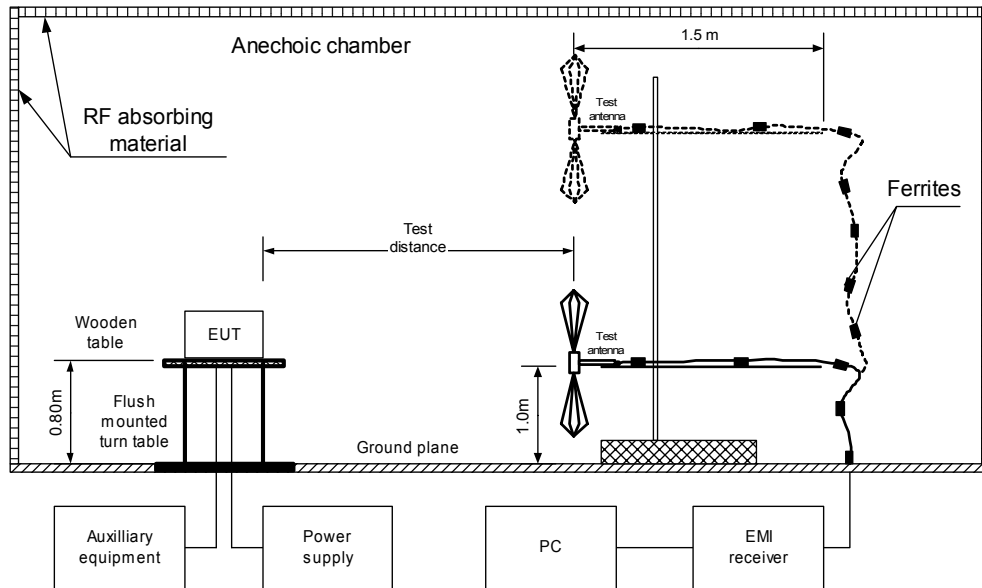
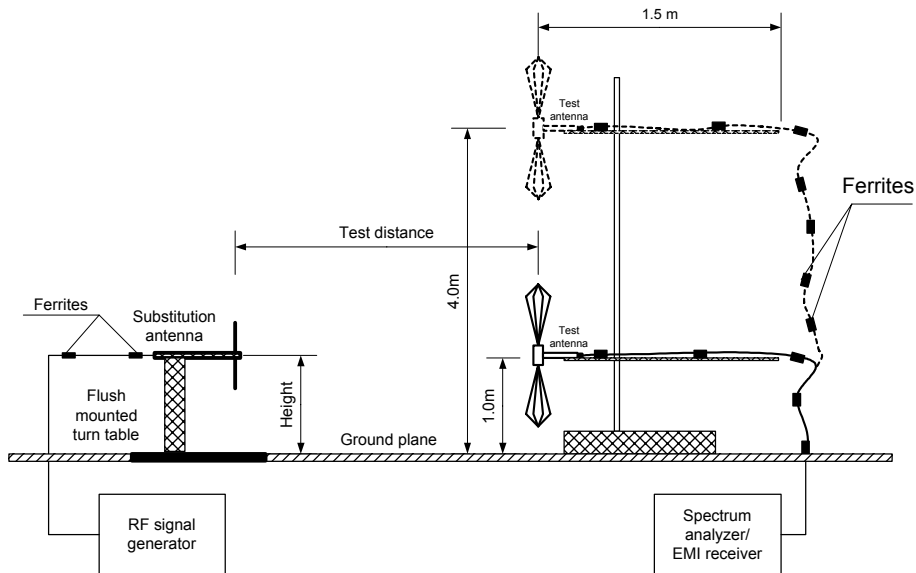

Figure 7.4.2 Setup for spurious emission field strength measurements above 30 MHz



Test specification:	Section 27.53(c)(2), Radiated spurious emissions		
Test procedure:	47 CFR, Section 2.1053, TIA/EIA-603-C, Section 2.2.12		
Test mode:	Compliance	Verdict:	PASS
Date:	11/22/2007		
Temperature: 24 °C	Air Pressure: 1016 hPa	Relative Humidity: 45 %	Power Supply: 120 VAC
Remarks:			

Figure 7.4.3 Setup for substitution ERP measurements of spurious





Test specification:	Section 27.53(c)(2), Radiated spurious emissions		
Test procedure:	47 CFR, Section 2.1053, TIA/EIA-603-C, Section 2.2.12		
Test mode:	Compliance	Verdict:	PASS
Date:	11/22/2007		
Temperature: 24 °C	Air Pressure: 1016 hPa	Relative Humidity: 45 %	Power Supply: 120 VAC
Remarks:			

Table 7.4.2 Spurious emission field strength test results

ASSIGNED FREQUENCY RANGE: 787.0 – 788.0 MHz
 TEST DISTANCE: 3 m
 EUT HEIGHT: 0.8 m
 INVESTIGATED FREQUENCY RANGE: 0.009 – 8000 MHz
 DETECTOR USED: Peak
 VIDEO BANDWIDTH: ≥ Resolution bandwidth
 TEST ANTENNA TYPE: Active loop (9 kHz – 30 MHz)
 Biconilog (30 MHz – 1000 MHz)
 Double ridged guide (above 1000 MHz)
 MODULATION: 16QAM, QPSK
 MODULATING SIGNAL: PRBS
 TRANSMITTER OUTPUT POWER SETTINGS: Maximum

Frequency, MHz	Antenna polarization	RBW, kHz	Field strength, dB(μV/m)	Limit, dB(μV/m)	Margin, dB*	Verdict
Low frequency						
2369.75	Vertical	1000	72.33	84.4	-12.07	Pass
High frequency						
2373.94	Horizontal	1000	72.43	84.4	-12.00	Pass

*- Margin = Field strength of spurious – calculated field strength limit.

Table 7.4.3 Substitution ERP of spurious test results

ASSIGNED FREQUENCY RANGE: 787.0 – 788.0 MHz
 TEST SITE: Semi anechoic chamber
 TEST DISTANCE: 3 m
 SUBSTITUTION ANTENNA HEIGHT: 0.8 m
 DETECTOR USED: Peak
 VIDEO BANDWIDTH: > Resolution bandwidth
 SUBSTITUTION ANTENNA TYPE: Tunable dipole (30 MHz – 1000 MHz)
 Double ridged guide (above 1000 MHz)

Frequency MHz	Field strength dB(μV/m)	RBW, kHz	Antenna polarization	RF generator output, dBm	Ant gain dBd	Cable loss, dB	ERP, dBm	Spurious emissions, dBm	Margin dB*	Verdict
Low carrier frequency										
2369.75	72.33	1000	Vertical	-30.79	6.94	1.62	-25.47	-13.00	-12.47	Pass
High carrier frequency										
2373.94	72.43	1000	Vertical	-30.83	6.96	1.62	-25.49	-13.00	-12.49	Pass

*- Margin = Spurious emission – specification limit.

Reference numbers of test equipment used

HL 0446	HL 0521	HL 0589	HL 0604	HL 0661	HL 1004	HL 1947	HL 2432
HL 2780	HL 2871						

Full description is given in Appendix A.



Test specification:	Section 27.53(c)(2), Radiated spurious emissions		
Test procedure:	47 CFR, Section 2.1053, TIA/EIA-603-C, Section 2.2.12		
Test mode:	Compliance	Verdict:	PASS
Date:	11/22/2007		
Temperature: 24 °C	Air Pressure: 1016 hPa	Relative Humidity: 45 %	Power Supply: 120 VAC
Remarks:			

Plot 7.4.1 Radiated emission measurements in 9 - 150 kHz range

TEST SITE: Semi anechoic chamber
 CARRIER FREQUENCY: Low
 ANTENNA POLARIZATION: Vertical
 TEST DISTANCE: 3 m
 MODULATION: QPSK

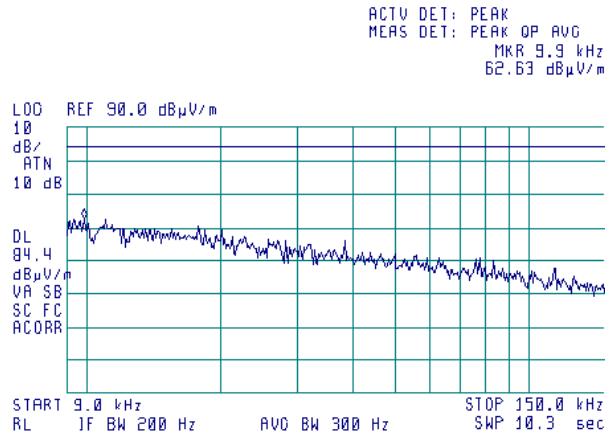

Plot 7.4.2 Radiated emission measurements in 9 - 150 kHz range

TEST SITE: Semi anechoic chamber
 CARRIER FREQUENCY: Low
 ANTENNA POLARIZATION: Vertical
 TEST DISTANCE: 3 m
 MODULATION: 16QAM

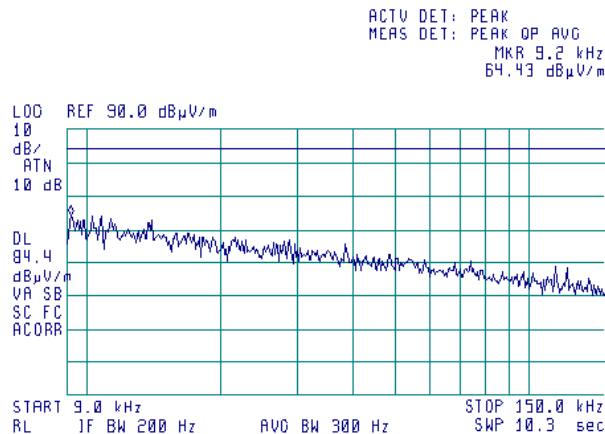



Test specification:	Section 27.53(c)(2), Radiated spurious emissions		
Test procedure:	47 CFR, Section 2.1053, TIA/EIA-603-C, Section 2.2.12		
Test mode:	Compliance	Verdict:	PASS
Date:	11/22/2007		
Temperature: 24 °C	Air Pressure: 1016 hPa	Relative Humidity: 45 %	Power Supply: 120 VAC
Remarks:			

Plot 7.4.3 Radiated emission measurements in 9 - 150 kHz range

TEST SITE: Semi anechoic chamber
 CARRIER FREQUENCY: High
 ANTENNA POLARIZATION: Vertical
 TEST DISTANCE: 3 m
 MODULATION: QPSK

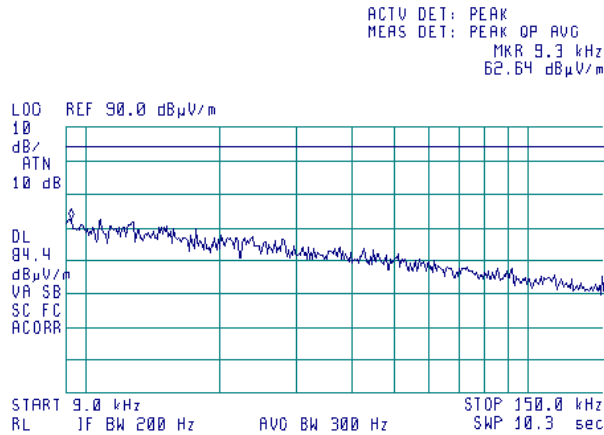

Plot 7.4.4 Radiated emission measurements in 9 - 150 kHz range

TEST SITE: Semi anechoic chamber
 CARRIER FREQUENCY: High
 ANTENNA POLARIZATION: Vertical
 TEST DISTANCE: 3 m
 MODULATION: 16QAM

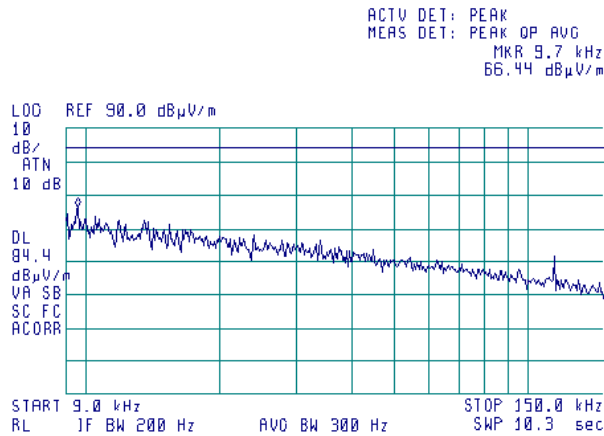



Test specification:	Section 27.53(c)(2), Radiated spurious emissions		
Test procedure:	47 CFR, Section 2.1053, TIA/EIA-603-C, Section 2.2.12		
Test mode:	Compliance	Verdict:	PASS
Date:	11/22/2007		
Temperature: 24 °C	Air Pressure: 1016 hPa	Relative Humidity: 45 %	Power Supply: 120 VAC
Remarks:			

Plot 7.4.5 Radiated emission measurements in 0.15 - 30 MHz range

TEST SITE: Semi anechoic chamber
 CARRIER FREQUENCY: Low
 ANTENNA POLARIZATION: Vertical
 TEST DISTANCE: 3 m
 MODULATION: QPSK

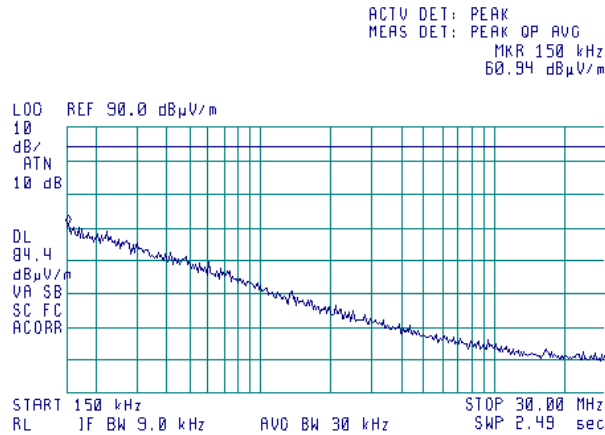

Plot 7.4.6 Radiated emission measurements in 0.15 - 30 MHz range

TEST SITE: Semi anechoic chamber
 CARRIER FREQUENCY: Low
 ANTENNA POLARIZATION: Vertical
 TEST DISTANCE: 3 m
 MODULATION: 16QAM

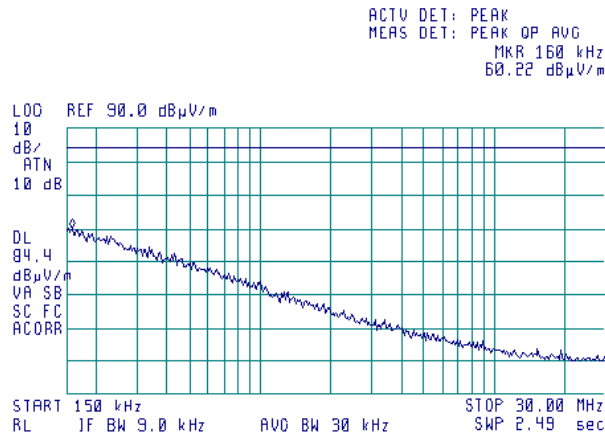



Test specification:	Section 27.53(c)(2), Radiated spurious emissions		
Test procedure:	47 CFR, Section 2.1053, TIA/EIA-603-C, Section 2.2.12		
Test mode:	Compliance	Verdict:	PASS
Date:	11/22/2007		
Temperature: 24 °C	Air Pressure: 1016 hPa	Relative Humidity: 45 %	Power Supply: 120 VAC
Remarks:			

Plot 7.4.7 Radiated emission measurements in 0.15 - 30 MHz range

TEST SITE: Semi anechoic chamber
 CARRIER FREQUENCY: High
 ANTENNA POLARIZATION: Vertical
 TEST DISTANCE: 3 m
 MODULATION: QPSK

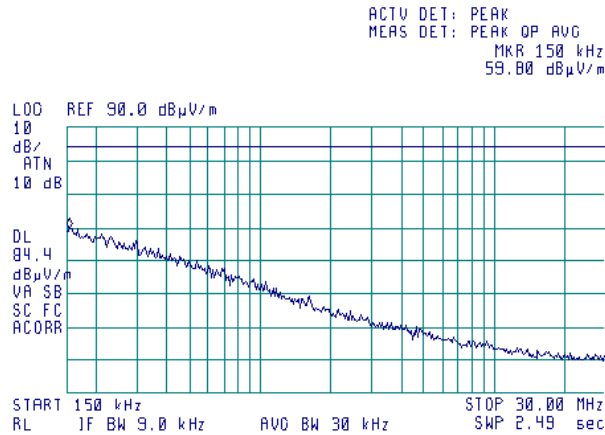

Plot 7.4.8 Radiated emission measurements in 0.15 - 30 MHz range

TEST SITE: Semi anechoic chamber
 CARRIER FREQUENCY: High
 ANTENNA POLARIZATION: Vertical
 TEST DISTANCE: 3 m
 MODULATION: 16QAM

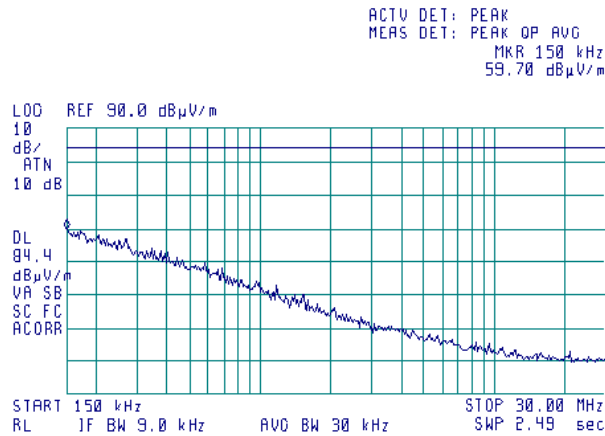



Test specification:	Section 27.53(c)(2), Radiated spurious emissions		
Test procedure:	47 CFR, Section 2.1053, TIA/EIA-603-C, Section 2.2.12		
Test mode:	Compliance	Verdict:	PASS
Date:	11/22/2007		
Temperature: 24 °C	Air Pressure: 1016 hPa	Relative Humidity: 45 %	Power Supply: 120 VAC
Remarks:			

Plot 7.4.9 Radiated emission measurements in 30 - 1000 MHz range

TEST SITE: Semi anechoic chamber
 CARRIER FREQUENCY: Low
 ANTENNA POLARIZATION: Vertical and Horizontal
 TEST DISTANCE: 3 m
 MODULATION: QPSK

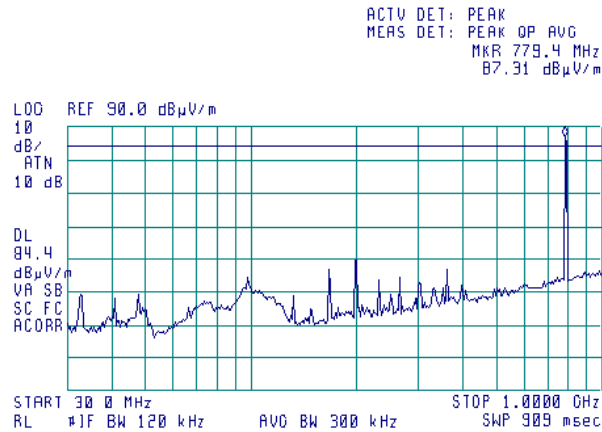

Note: 787.1625 MHz – intentional radiation of RF module

Plot 7.4.10 Radiated emission measurements in 30 - 1000 MHz range

TEST SITE: Semi anechoic chamber
 CARRIER FREQUENCY: Low
 ANTENNA POLARIZATION: Vertical and Horizontal
 TEST DISTANCE: 3 m
 MODULATION: 16QAM

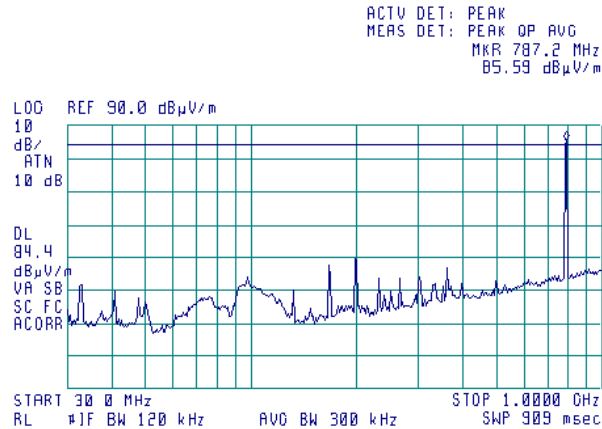

Note: 787.1625 MHz – intentional radiation of RF module



Test specification:	Section 27.53(c)(2), Radiated spurious emissions		
Test procedure:	47 CFR, Section 2.1053, TIA/EIA-603-C, Section 2.2.12		
Test mode:	Compliance	Verdict:	PASS
Date:	11/22/2007		
Temperature: 24 °C	Air Pressure: 1016 hPa	Relative Humidity: 45 %	Power Supply: 120 VAC
Remarks:			

Plot 7.4.11 Radiated emission measurements in 30 - 1000 MHz range

TEST SITE: Semi anechoic chamber
 CARRIER FREQUENCY: High
 ANTENNA POLARIZATION: Vertical and Horizontal
 TEST DISTANCE: 3 m
 MODULATION: QPSK

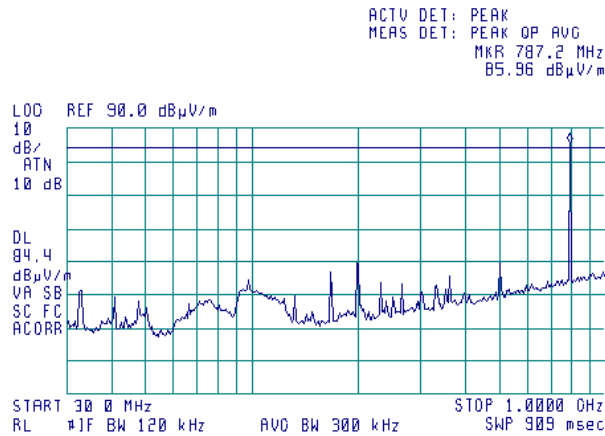

Note: 787.8375 MHz – intentional radiation of RF module

Plot 7.4.12 Radiated emission measurements in 30 - 1000 MHz range

TEST SITE: Semi anechoic chamber
 CARRIER FREQUENCY: High
 ANTENNA POLARIZATION: Vertical and Horizontal
 TEST DISTANCE: 3 m
 MODULATION: 16QAM

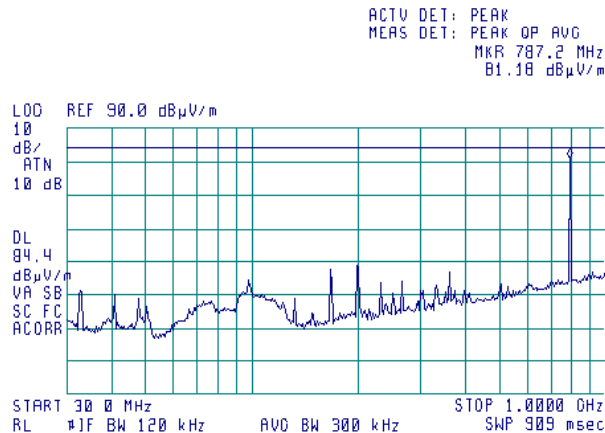

Note: 787.8375 MHz – intentional radiation of RF module



Test specification:	Section 27.53(c)(2), Radiated spurious emissions		
Test procedure:	47 CFR, Section 2.1053, TIA/EIA-603-C, Section 2.2.12		
Test mode:	Compliance	Verdict:	PASS
Date:	11/22/2007		
Temperature: 24 °C	Air Pressure: 1016 hPa	Relative Humidity: 45 %	Power Supply: 120 VAC
Remarks:			

Plot 7.4.13 Radiated emission measurements in 1 – 2.9 GHz range

TEST SITE: Semi anechoic chamber
 CARRIER FREQUENCY: Low
 ANTENNA POLARIZATION: Vertical and Horizontal
 TEST DISTANCE: 3 m
 MODULATION: QPSK

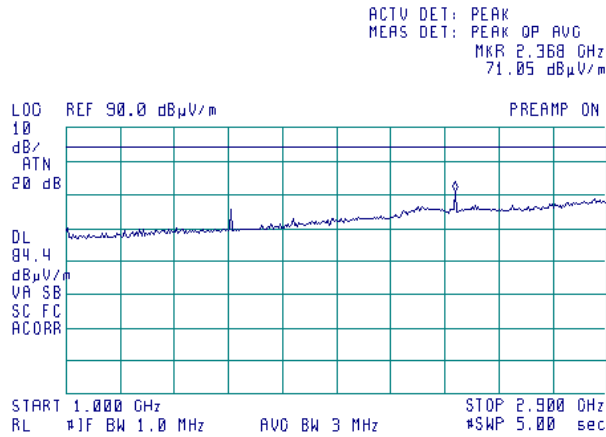

Plot 7.4.14 Radiated emission measurements in 1 – 2.9 GHz range

TEST SITE: Semi anechoic chamber
 CARRIER FREQUENCY: Low
 ANTENNA POLARIZATION: Vertical and Horizontal
 TEST DISTANCE: 3 m
 MODULATION: 16QAM

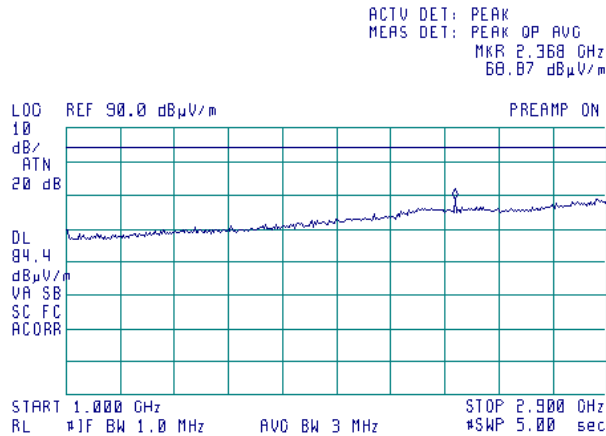



Test specification:	Section 27.53(c)(2), Radiated spurious emissions		
Test procedure:	47 CFR, Section 2.1053, TIA/EIA-603-C, Section 2.2.12		
Test mode:	Compliance	Verdict:	PASS
Date:	11/22/2007		
Temperature: 24 °C	Air Pressure: 1016 hPa	Relative Humidity: 45 %	Power Supply: 120 VAC
Remarks:			

Plot 7.4.15 Radiated emission measurements in 1 – 2.9 GHz range

TEST SITE: Semi anechoic chamber
 CARRIER FREQUENCY: High
 ANTENNA POLARIZATION: Vertical and Horizontal
 TEST DISTANCE: 3 m
 MODULATION: QPSK

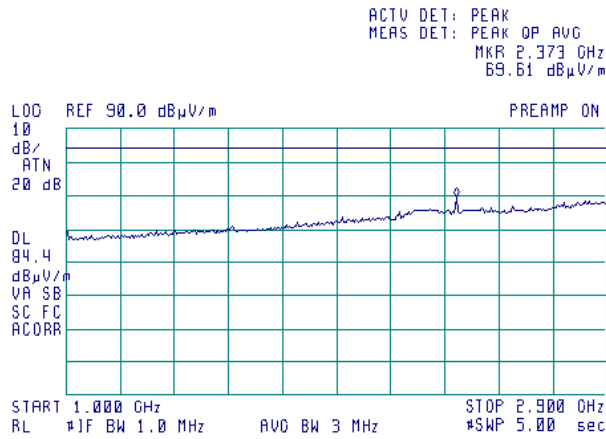

Plot 7.4.16 Radiated emission measurements in 1 – 2.9 GHz range

TEST SITE: Semi anechoic chamber
 CARRIER FREQUENCY: High
 ANTENNA POLARIZATION: Vertical and Horizontal
 TEST DISTANCE: 3 m
 MODULATION: 16QAM

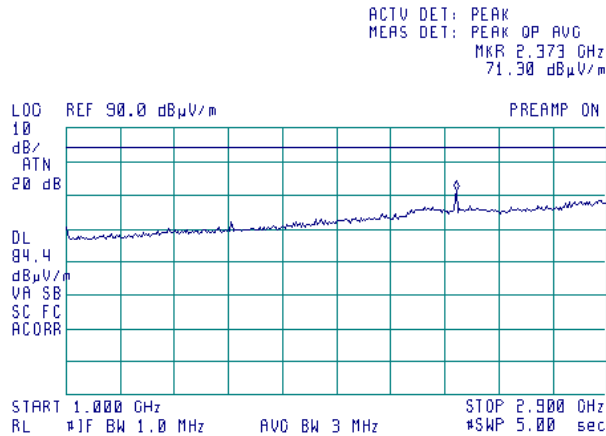

Test specification:	Section 27.53(c)(2), Radiated spurious emissions		
Test procedure:	47 CFR, Section 2.1053, TIA/EIA-603-C, Section 2.2.12		
Test mode:	Compliance	Verdict:	PASS
Date:	11/22/2007		
Temperature: 24 °C	Air Pressure: 1016 hPa	Relative Humidity: 45 %	Power Supply: 120 VAC
Remarks:			

Plot 7.4.17 Radiated emission measurements in 2.9 – 8.0 GHz range

TEST SITE: Anechoic chamber
 CARRIER FREQUENCY: Low
 ANTENNA POLARIZATION: Vertical and Horizontal
 TEST DISTANCE: 3 m
 MODULATION: QPSK

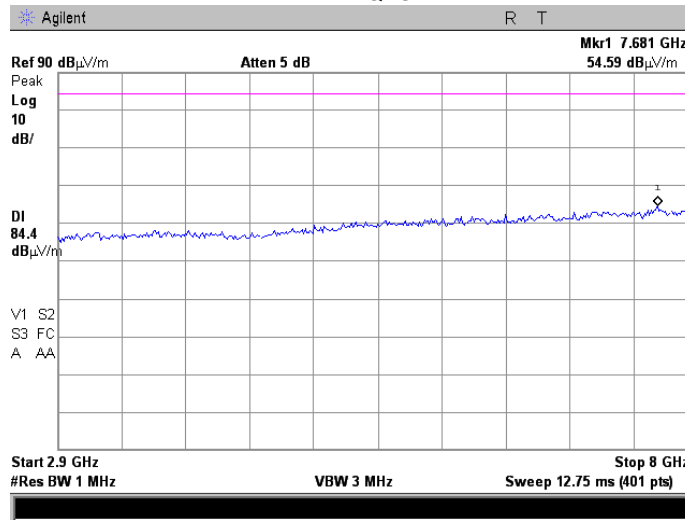

Plot 7.4.18 Radiated emission measurements in 2.9 – 8.0 GHz range

TEST SITE: Anechoic chamber
 CARRIER FREQUENCY: Low
 ANTENNA POLARIZATION: Vertical and Horizontal
 TEST DISTANCE: 3 m
 MODULATION: 16QAM

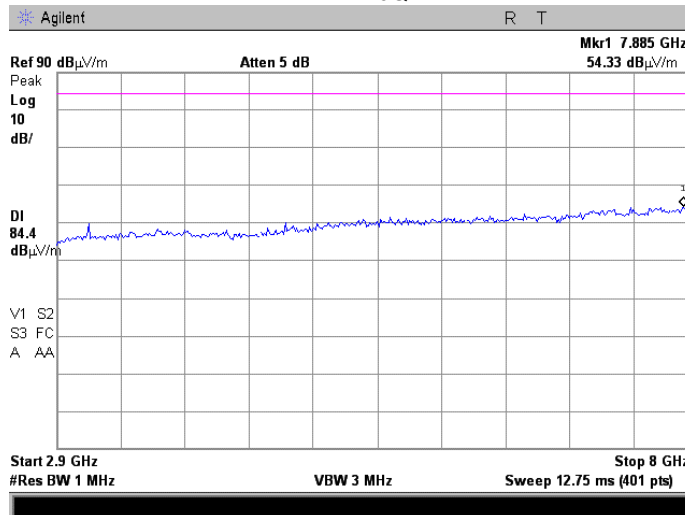

Test specification:	Section 27.53(c)(2), Radiated spurious emissions		
Test procedure:	47 CFR, Section 2.1053, TIA/EIA-603-C, Section 2.2.12		
Test mode:	Compliance	Verdict:	PASS
Date:	11/22/2007		
Temperature: 24 °C	Air Pressure: 1016 hPa	Relative Humidity: 45 %	Power Supply: 120 VAC
Remarks:			

Plot 7.4.19 Radiated emission measurements in 2.9 – 8.0 GHz range

TEST SITE: Anechoic chamber
 CARRIER FREQUENCY: High
 ANTENNA POLARIZATION: Vertical and Horizontal
 TEST DISTANCE: 3 m
 MODULATION: QPSK

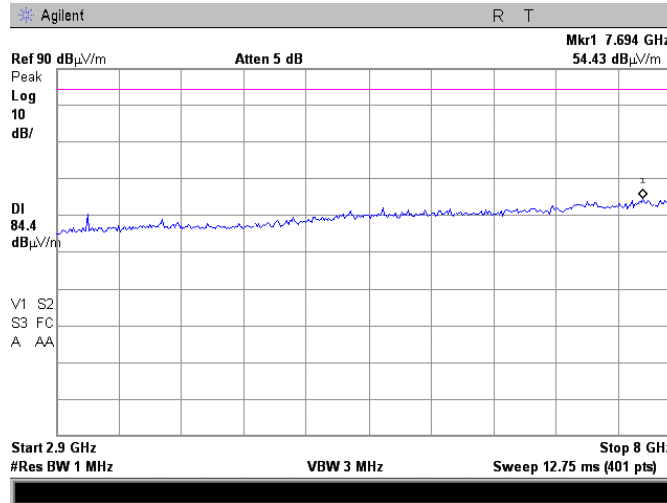

Plot 7.4.20 Radiated emission measurements in 2.9 – 8.0 GHz range

TEST SITE: Anechoic chamber
 CARRIER FREQUENCY: High
 ANTENNA POLARIZATION: Vertical and Horizontal
 TEST DISTANCE: 3 m
 MODULATION: 16QAM

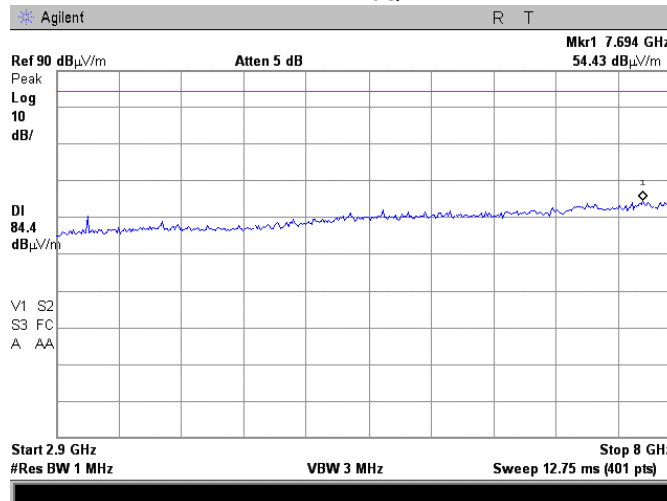



Test specification:	Section 27.53(f), Radiated emissions in the 1559-1610 MHz band		
Test procedure:	ANSI C63.4, Sections 11.5 and 12.1.3; TIA/EIA-603-C, Section 2.2.12		
Test mode:	Compliance	Verdict:	PASS
Date:	11/25/2007		
Temperature: 23 °C	Air Pressure: 1009 hPa	Relative Humidity: 48%	Power Supply: 120 VAC
Remarks:			

7.5 Radiated spurious emission measurements in 1559-1610 MHz band

7.5.1 General

This test was performed to measure radiated spurious emissions from the EUT enclosure with antenna. Specification test limits are given in Table 7.5.1.

Table 7.5.1 Radiated spurious emission test limits

Frequency, MHz	Type of signal	EIRP of spurious emissions, dBW/MHz	Spurious emissions, dBm	Equivalent field strength limit @ 3m, dB(μV/m)
1559 - 1610	Wideband	-70	-40	55.23
	Discrete or less than 700 Hz BW	-80	-50	45.23

7.5.2 Test procedure for spurious emission field strength measurements above 30 MHz

7.5.2.1 The EUT was set up as shown in Figure 7.5.1, energized and the EUT performance was checked.

7.5.2.2 The specified frequency range was investigated with antennas connected to spectrum analyzer. To find maximum radiation the turntable was rotated 360° and the measuring antenna height was swept from 1 to 4 m in both, vertical and horizontal, polarizations.

7.5.2.3 The worst test results with respect to the limits were recorded in Table 7.5.2 and shown in the associated plots.



Test specification:	Section 27.53(f), Radiated emissions in the 1559-1610 MHz band		
Test procedure:	ANSI C63.4, Sections 11.5 and 12.1.3; TIA/EIA-603-C, Section 2.2.12		
Test mode:	Compliance	Verdict:	PASS
Date:	11/25/2007		
Temperature: 23 °C	Air Pressure: 1009 hPa	Relative Humidity: 48%	Power Supply: 120 VAC
Remarks:			

Figure 7.5.1 Setup for spurious emission field strength measurements

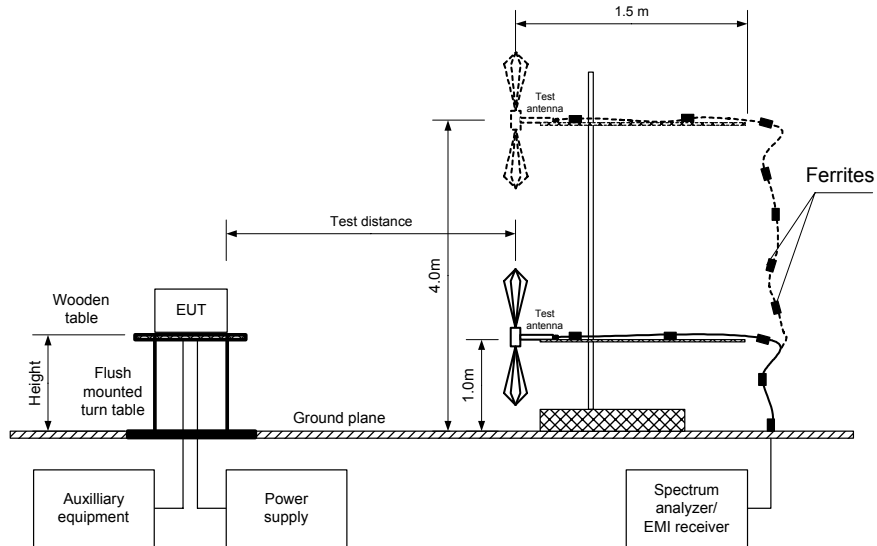



Test specification:	Section 27.53(f), Radiated emissions in the 1559-1610 MHz band		
Test procedure:	ANSI C63.4, Sections 11.5 and 12.1.3; TIA/EIA-603-C, Section 2.2.12		
Test mode:	Compliance	Verdict:	PASS
Date:	11/25/2007		
Temperature: 23 °C	Air Pressure: 1009 hPa	Relative Humidity: 48%	Power Supply: 120 VAC
Remarks:			

Table 7.5.2 Spurious emission field strength test

ASSIGNED FREQUENCY RANGE: 787.0 – 788.0 MHz
TEST SITE: OATS
TEST DISTANCE: 3 m
EUT HEIGHT: 0.8 m
INVESTIGATED FREQUENCY RANGE: 1559 – 1610 MHz
DETECTOR USED: Peak
VIDEO BANDWIDTH: ≥ Resolution bandwidth
TEST ANTENNA TYPE: Double ridged guide
MODULATION: QPSK
MODULATING SIGNAL: PRBS
TRANSMITTER OUTPUT POWER SETTINGS: Maximum

Frequency, MHz	Antenna polarization	RBW, kHz	Field strength, dB(μV/m)	Limit, dB(μV/m)	Margin, dB*	Verdict
No emissions were found						Pass

*- Margin = Field strength of spurious – calculated field strength limit.

** -For wideband signals emissions in the band 775-792 MHz shall be limited to -70 dBW/MHz equivalent isotropically radiated power (EIRP)

Reference numbers of test equipment used

HL 0415	HL 0812	HL 1430	HL 2432			
---------	---------	---------	---------	--	--	--

Full description is given in Appendix A.



Test specification:	Section 27.53(f), Radiated emissions in the 1559-1610 MHz band		
Test procedure:	ANSI C63.4, Sections 11.5 and 12.1.3; TIA/EIA-603-C, Section 2.2.12		
Test mode:	Compliance	Verdict:	PASS
Date:	11/25/2007		
Temperature: 23 °C	Air Pressure: 1009 hPa	Relative Humidity: 48%	Power Supply: 120 VAC
Remarks:			

Plot 7.5.1 Radiated emission measurements in 1559 - 1610 MHz range

TEST SITE:	OATS
CARRIER FREQUENCY:	Low
ANTENNA POLARIZATION:	Vertical and Horizontal
TEST DISTANCE:	3 m
MODULATION:	QPSK

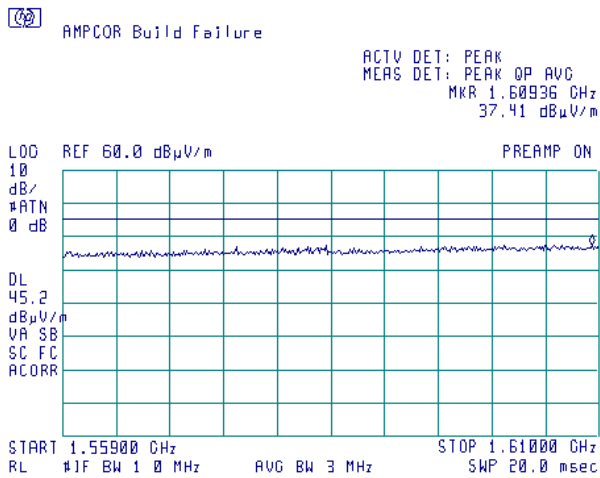



Test specification:	Section 27.53(f), Radiated emissions in the 1559-1610 MHz band		
Test procedure:	ANSI C63.4, Sections 11.5 and 12.1.3; TIA/EIA-603-C, Section 2.2.12		
Test mode:	Compliance	Verdict:	PASS
Date:	11/25/2007		
Temperature: 23 °C	Air Pressure: 1009 hPa	Relative Humidity: 48%	Power Supply: 120 VAC
Remarks:			

Plot 7.5.2 Radiated emission measurements in 1559 - 1610 MHz range

TEST SITE: Semi anechoic chamber
 CARRIER FREQUENCY: High
 ANTENNA POLARIZATION: Vertical and Horizontal
 TEST DISTANCE: 3 m
 MODULATION: QPSK



AMPCOR Build Failure

ACTV DET: PEAK
 MEAS DET: PEAK QP AVG
 MKR 1.60834 CHz
 38.25 dBµV/m

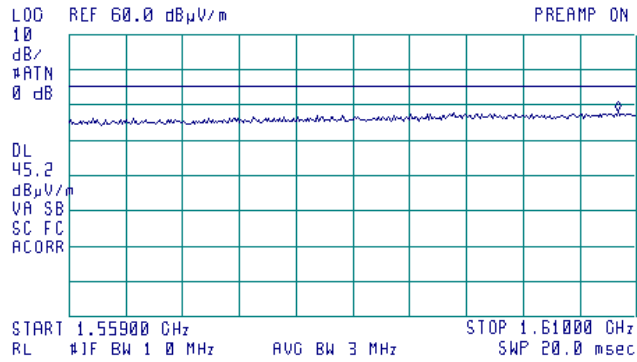

Test specification:	Section 27.54, Frequency stability		
Test procedure:	47 CFR, Section 2.1055, TIA/EIA-603-C, Section 2.2.2		
Test mode:	Compliance	Verdict:	PASS
Date:	11/28/2007		
Temperature: 23 °C	Air Pressure: 1012 hPa	Relative Humidity: 45 %	Power Supply: 120 VAC
Remarks:			

7.6 Frequency stability test

7.6.1 General

This test was performed to measure frequency stability of transmitter RF carrier. Specification test limits are given in Table 7.6.1. The test results are provided in Tables 7.6.2, 7.6.3 and shown in the associated plots.

Table 7.6.1 Frequency stability limits

Assigned frequency, MHz	Maximum allowed frequency displacement
787.0 – 788.0	26 dBc points including frequency tolerance shall remain within the assigned band

7.6.2 Test procedure

- 7.6.2.1 The EUT was set up as shown in Figure 7.6.1, energized and its proper operation was checked.
- 7.6.2.2 The EUT power was turned off. Temperature within test chamber was set to +30°C and a period of time sufficient to stabilize all of the oscillator circuit components was allowed.
- 7.6.2.3 The EUT was powered on and carrier frequency was measured at start up moment and then every minute until frequency had been stabilized or 10 minutes elapsed whichever reached the last. The EUT was powered off.
- 7.6.2.4 The above procedure was repeated at 0°C and at the lowest test temperature.
- 7.6.2.5 The EUT was powered on and carrier frequency was measured at start up moment and at the end of stabilization period at the rest of test temperatures and voltages. The EUT was powered off.
- 7.6.2.6 Frequency displacement was calculated as provided in Table 7.6.2 and Table 7.6.3.

Figure 7.6.1 Frequency stability test setup

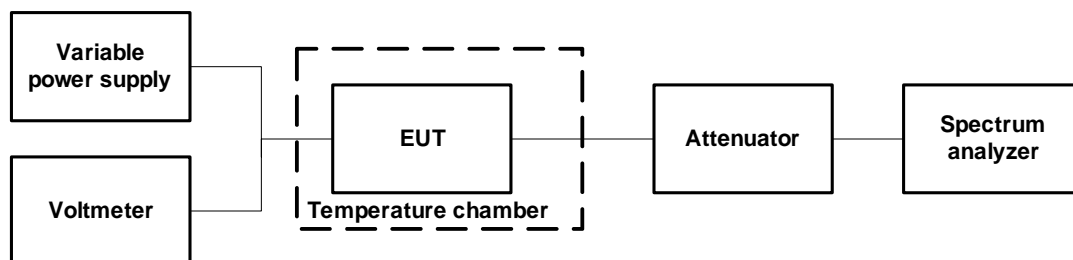



Test specification:	Section 27.54, Frequency stability		
Test procedure:	47 CFR, Section 2.1055, TIA/EIA-603-C, Section 2.2.2		
Test mode:	Compliance	Verdict:	PASS
Date:	11/28/2007		
Temperature: 23 °C	Air Pressure: 1012 hPa	Relative Humidity: 45 %	Power Supply: 120 VAC
Remarks:			

Table 7.6.2 Frequency stability test results

ASSIGNED FREQUENCY RANGE: 787.0 – 788.0 MHz
 NOMINAL POWER VOLTAGE: 120 VAC (102 VAC - 138 VAC)
 TEMPERATURE STABILIZATION PERIOD: 20 min
 POWER DURING TEMPERATURE TRANSITION: Off
 RESOLUTION BANDWIDTH: 300 Hz
 VIDEO BANDWIDTH: 300 Hz
 FREQUENCY SPAN: 10.0 kHz
 SPECTRUM ANALYZER MODE: Counter
 MODULATION: Unmodulated

T, °C	Voltage, V	Frequency, MHz							Max frequency drift, Hz	
		Start up	1 st min	2 nd min	3 rd min	4 th min	5 th min	10 th min	Positive	Negative
Low frequency, 787.01500 MHz										
-30	nominal	787.165067	787.164925	787.164883	787.164850	787.164768	787.164741	787.164608	2142	0
-20	nominal	787.163883	NA	NA	NA	NA	NA	787.163850	958	0
-10	nominal	787.163742	NA	NA	NA	NA	NA	787.163592	817	0
0	nominal	787.163383	787.163367	787.163350	787.163342	787.163325	787.163334	787.163317	458	0
10	nominal	787.163658	NA	NA	NA	NA	NA	787.163608	733	0
20	15%	787.163117	NA	NA	NA	NA	NA	787.163174	249	0
20	nominal	787.162572	NA	NA	NA	NA	NA	787.162925	0	0
20	-15%	787.163101	NA	NA	NA	NA	NA	787.163150	225	0
30	nominal	787.163425	787.163300	787.163258	787.163175	787.163075	787.163058	787.162883	500	-42
40	nominal	787.162292	NA	NA	NA	NA	NA	787.162208	0	-717
50	nominal	787.162358	NA	NA	NA	NA	NA	787.162483	0	-567
High frequency, 787.98375 MHz										
-30	nominal	787.840050	787.839967	787.839917	787.839867	787.839817	787.839808	787.839683	1925	0
-20	nominal	787.838975	NA	NA	NA	NA	NA	787.838908	850	0
-10	nominal	787.838617	NA	NA	NA	NA	NA	787.838533	492	0
0	nominal	787.837325	787.838333	787.838333	787.838330	787.838325	787.838333	787.838333	208	-800
10	nominal	787.838833	NA	NA	NA	NA	NA	787.838708	0	0
20	15%	787.838167	NA	NA	NA	NA	NA	787.838433	0	0
20	nominal	787.837893	NA	NA	NA	NA	NA	787.838125	0	-232
20	-15%	787.838167	NA	NA	NA	NA	NA	787.838183	58	0
30	nominal	787.837883	787.837858	787.837858	787.837825	787.837842	787.837825	787.837783	0	-342
40	nominal	787.837733	NA	NA	NA	NA	NA	787.837292	0	-833
50	nominal	787.837517	NA	NA	NA	NA	NA	787.837617	0	-608

* - Reference frequency



Test specification:	Section 27.54, Frequency stability		
Test procedure:	47 CFR, Section 2.1055, TIA/EIA-603-C, Section 2.2.2		
Test mode:	Compliance	Verdict:	PASS
Date:	11/28/2007		
Temperature: 23 °C	Air Pressure: 1012 hPa	Relative Humidity: 45 %	Power Supply: 120 VAC
Remarks:			

Table 7.6.3 Transmitter operating range including frequency drift

Assigned frequency band, MHz	Measured 26 dBc point, MHz	Frequency drift, Hz		26 dBc point including frequency tolerance, MHz	Verdict
		Negative	Positive		
Low frequency QPSK, channel bandwidth 325 kHz					
787.0 – 788.0	787.020800-787.305800	-717	2412	787.020083 – 787.308212	Pass
Low frequency 16QAM, channel bandwidth 325 kHz					
787.0 – 788.0	787.027500-787.296700	-717	2412	787.026783 – 787.299112	Pass
High frequency QPSK, channel bandwidth 325 kHz					
787.0 – 788.0	787.695800-787.980800	-833	1925	787.694967 – 787.982725	Pass
High frequency 16QAM, channel bandwidth 325 kHz					
787.0 – 788.0	787.701700-787.971700	-833	1925	787.700867 – 787.973625	Pass

Reference numbers of test equipment used

HL 0493	HL 2780	HL 3108					
---------	---------	---------	--	--	--	--	--

Full description is given in Appendix A.



Test specification:	Section 27.54, Frequency stability		
Test procedure:	47 CFR, Section 2.1055, TIA/EIA-603-C, Section 2.2.2		
Test mode:	Compliance	Verdict:	PASS
Date:	11/28/2007		
Temperature: 23 °C	Air Pressure: 1012 hPa	Relative Humidity: 45 %	Power Supply: 120 VAC
Remarks:			

Plot 7.6.1 Band edge emission at low frequency, QPSK

Band edge: Left
Channel Bandwidth: 325 kHz

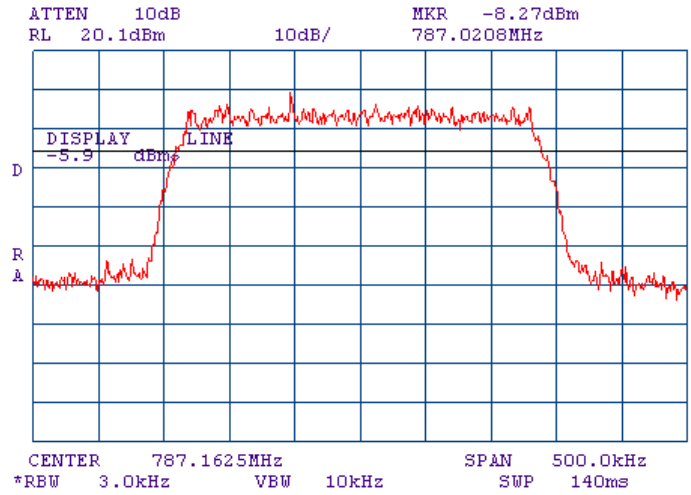

Plot 7.6.2 Band edge emission at low frequency, QPSK

Band edge: Right
Channel Bandwidth: 325 kHz

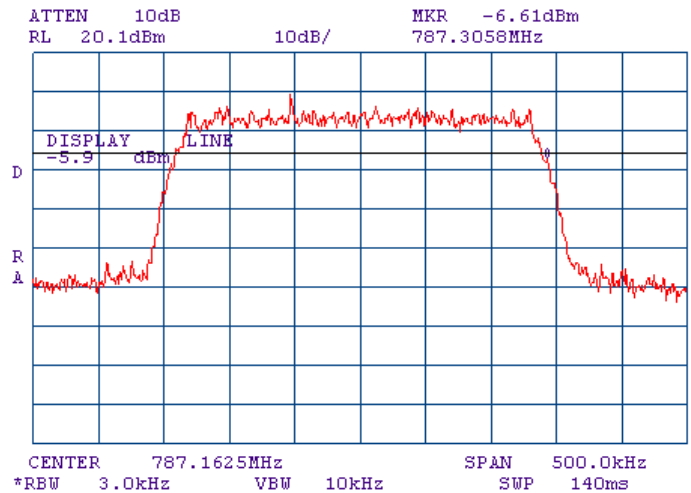

Test specification:	Section 27.54, Frequency stability		
Test procedure:	47 CFR, Section 2.1055, TIA/EIA-603-C, Section 2.2.2		
Test mode:	Compliance	Verdict:	PASS
Date:	11/28/2007		
Temperature: 23 °C	Air Pressure: 1012 hPa	Relative Humidity: 45 %	Power Supply: 120 VAC
Remarks:			

Plot 7.6.3 Band edge emission at low frequency, 16QAM

Band edge: Left
Channel Bandwidth: 325 kHz

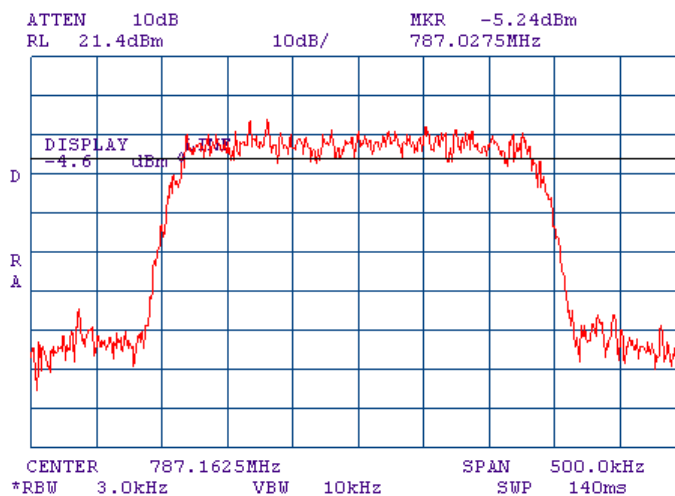

Plot 7.6.4 Band edge emission at low frequency, 16QAM

Band edge: Right
Channel Bandwidth: 325 kHz

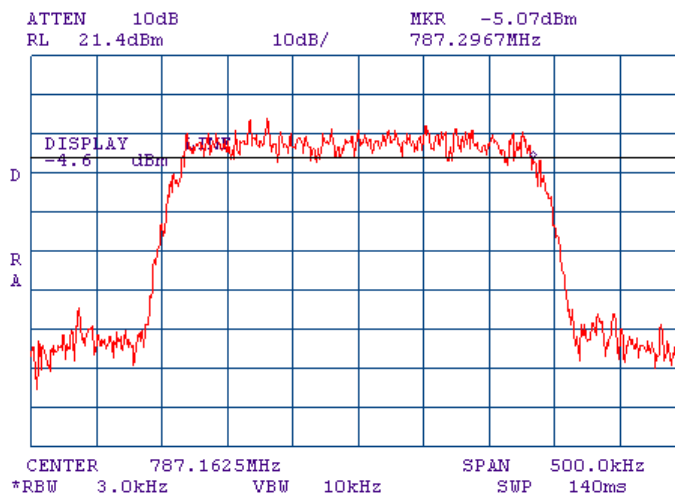



Test specification:	Section 27.54, Frequency stability		
Test procedure:	47 CFR, Section 2.1055, TIA/EIA-603-C, Section 2.2.2		
Test mode:	Compliance	Verdict:	PASS
Date:	11/28/2007		
Temperature: 23 °C	Air Pressure: 1012 hPa	Relative Humidity: 45 %	Power Supply: 120 VAC
Remarks:			

Plot 7.6.5 Band edge emission at high frequency, QPSK

Band edge: left
Channel Bandwidth: 325 kHz

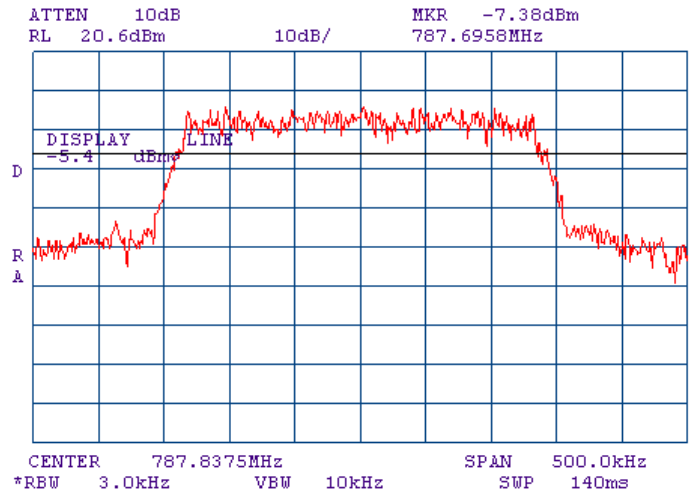

Plot 7.6.6 Band edge emission at high frequency, QPSK

Band edge: Right
Channel Bandwidth: 325 kHz

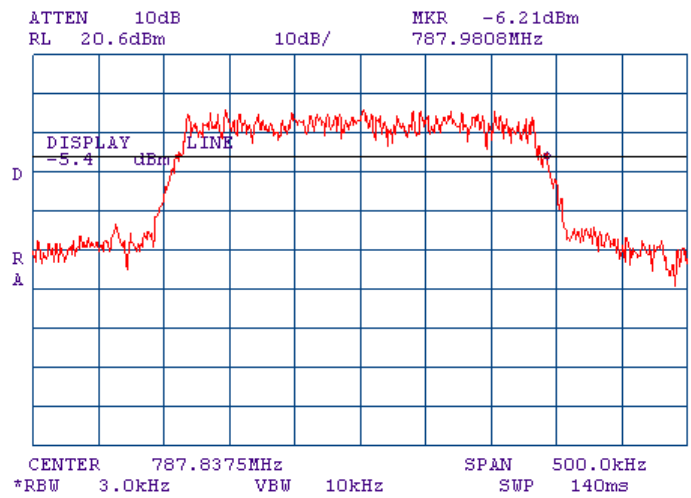



Test specification:	Section 27.54, Frequency stability		
Test procedure:	47 CFR, Section 2.1055, TIA/EIA-603-C, Section 2.2.2		
Test mode:	Compliance	Verdict:	PASS
Date:	11/28/2007		
Temperature: 23 °C	Air Pressure: 1012 hPa	Relative Humidity: 45 %	Power Supply: 120 VAC
Remarks:			

Plot 7.6.7 Band edge emission at high frequency, 16QAM

Band edge: Left
 Channel Bandwidth: 325 kHz

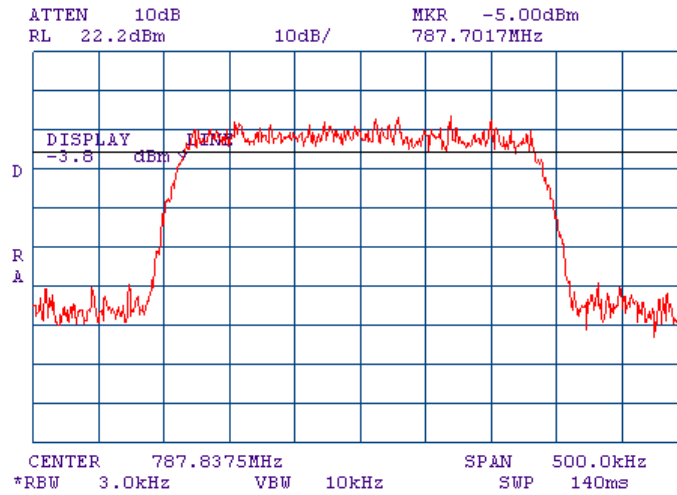

Plot 7.6.8 Band edge emission at high frequency, 16QAM

Band edge: Right
 Channel Bandwidth: 325 kHz

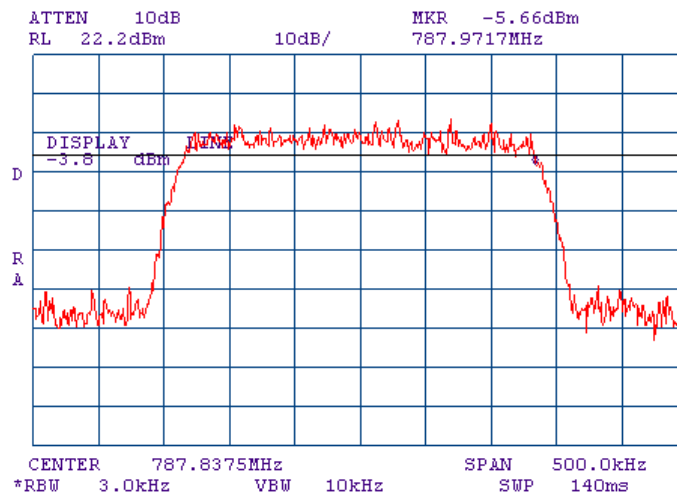

Test specification:	Section 2.1049, Occupied bandwidth		
Test procedure:	47 CFR, Section 2.1049		
Test mode:	Compliance	Verdict:	PASS
Date:	11/27/2007		
Temperature: 23 °C	Air Pressure: 1013 hPa	Relative Humidity: 45 %	Power Supply: 120 VAC
Remarks:			

7.7 Occupied bandwidth test

7.7.1 General

This test was performed to measure transmitter occupied bandwidth. Specification test limits are given in Table 7.7.1.

Table 7.7.1 Occupied bandwidth limits

Assigned frequency, MHz	Modulation envelope reference points*, dBc
787.0 – 788.0	26

* - Modulation envelope reference points provided in terms of attenuation below unmodulated carrier.

7.7.2 Test procedure

- 7.7.2.1 The EUT was set up as shown in Figure 7.7.1, energized and its proper operation was checked.
- 7.7.2.2 The EUT was set to transmit unmodulated carrier and reference peak power level was measured.
- 7.7.2.3 The EUT was set to transmit modulated carrier.
- 7.7.2.4 The transmitter occupied bandwidth was measured with spectrum analyzer as frequency delta between reference points on modulation envelope and provided in Table 7.7.2 and associated plots.

Figure 7.7.1 Occupied bandwidth test setup

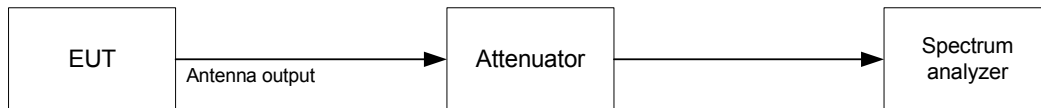



Test specification:	Section 2.1049, Occupied bandwidth		
Test procedure:	47 CFR, Section 2.1049		
Test mode:	Compliance	Verdict:	PASS
Date:	11/27/2007		
Temperature: 23 °C	Air Pressure: 1013 hPa	Relative Humidity: 45 %	Power Supply: 120 VAC
Remarks:			

Table 7.7.2 Occupied bandwidth test results

DETECTOR USED: Peak hold
 RESOLUTION BANDWIDTH: 3 kHz
 VIDEO BANDWIDTH: 10 kHz
 MODULATION ENVELOPE REFERENCE POINTS: 26 dBc
 MODULATING SIGNAL: PRBS

Carrier frequency, MHz	Occupied bandwidth, kHz
Bit rate: 0.52 Mbps / Modulation: QPSK	
787.1625	307.5
787.8375	304.2
Bit rate: 1.040 Mbps / Modulation: 16QAM	
787.1625	270.0
787.8375	273.3

Reference numbers of test equipment used

HL 1424	HL 2011	HL 2867	HL 2869	HL 3175	HL 3180		
---------	---------	---------	---------	---------	---------	--	--

Full description is given in Appendix A.



Test specification:	Section 2.1049, Occupied bandwidth		
Test procedure:	47 CFR, Section 2.1049		
Test mode:	Compliance	Verdict:	PASS
Date:	11/27/2007		
Temperature: 23 °C	Air Pressure: 1013 hPa	Relative Humidity: 45 %	Power Supply: 120 VAC
Remarks:			

Plot 7.7.1 Occupied bandwidth test results at low frequency

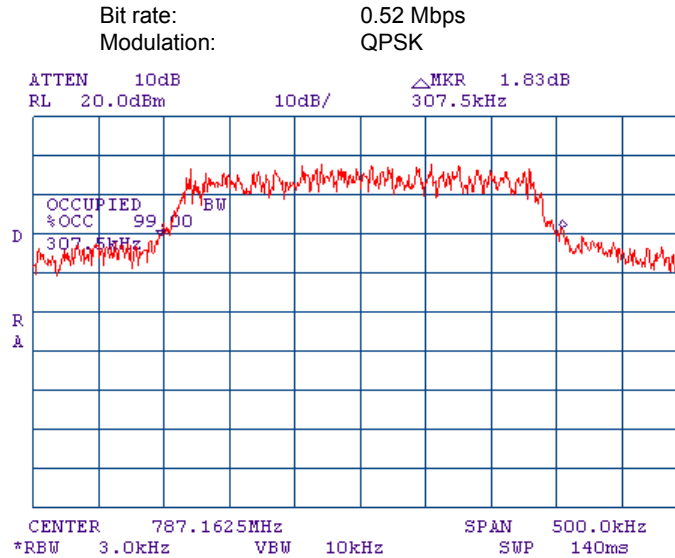

Plot 7.7.2 Occupied bandwidth test results at low frequency

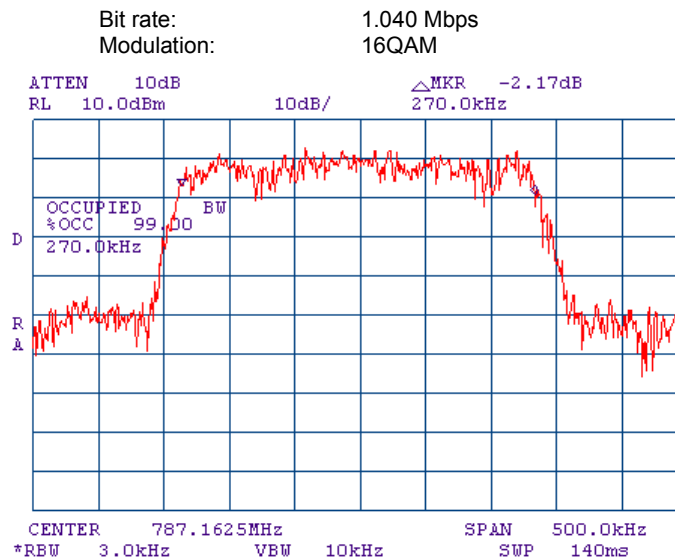



Test specification:	Section 2.1049, Occupied bandwidth		
Test procedure:	47 CFR, Section 2.1049		
Test mode:	Compliance	Verdict:	PASS
Date:	11/27/2007		
Temperature: 23 °C	Air Pressure: 1013 hPa	Relative Humidity: 45 %	Power Supply: 120 VAC
Remarks:			

Plot 7.7.3 Occupied bandwidth test results at high frequency

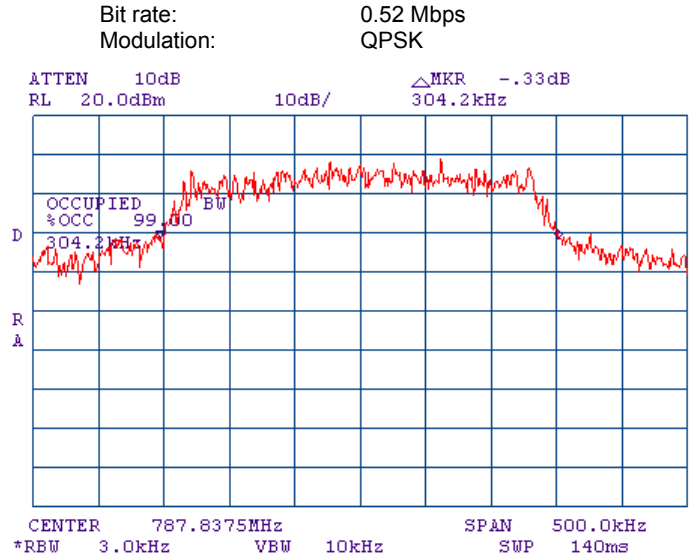

Plot 7.7.4 Occupied bandwidth test results at high frequency

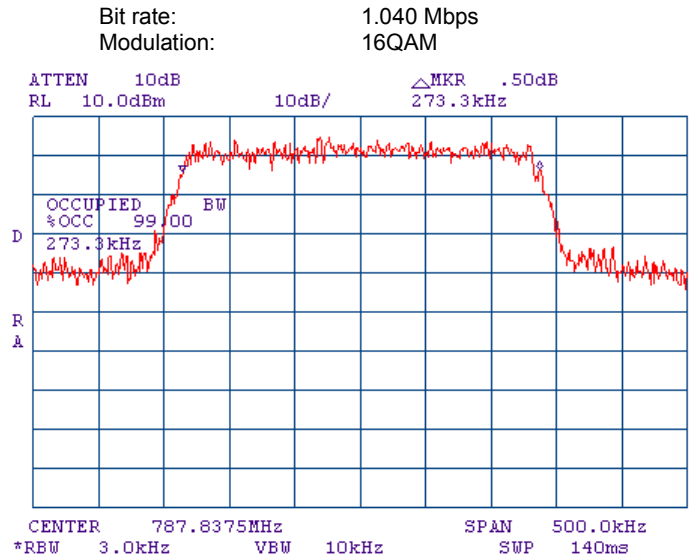

Test specification:	Section 15.107, Conducted emission at AC power port, Class A		
Test procedure:	ANSI C63.4, Sections 11.5 and 12.1.3		
Test mode:	Compliance	Verdict:	PASS
Date:	11/26/2007		
Temperature: 23 °C	Air Pressure: 1012 hPa	Relative Humidity: 46 %	Power Supply: 120 VAC
Remarks:			

8 Emissions tests according to 47CFR part 15 subpart B requirements

8.1 Conducted emissions

8.1.1 General

This test was performed to measure common mode conducted emissions at the mains power port. The specification test limits are given in Table 8.1.1.

Table 8.1.1 Limits for conducted emissions

Frequency, MHz	Class B limit, dB(μV)		Class A limit, dB(μV)	
	QP	AVRG	QP	AVRG
0.15 - 0.5	66 - 56*	56 - 46*	79	66
0.5 - 5.0	56	46	73	60
5.0 - 30	60	50	73	60

* The limit decreases linearly with the logarithm of frequency.

8.1.2 Test procedure

8.1.2.1 The EUT was set up as shown in Figure 8.1.1, energized and the EUT performance was checked.

8.1.2.2 The measurements were performed at the EUT power terminals with the LISN, connected to the EMI receiver in the frequency range referred to in Table 8.1.2, Table 8.1.3. The unused coaxial connector of the LISN was terminated with 50 Ohm.

8.1.2.3 The position of the device cables was varied to determine maximum emission level. The worst test results with respect to the limits were recorded in Table 8.1.2 and shown in the associated plots.

Figure 8.1.1 Setup for conducted emission measurements at the mains power port, table-top EUT

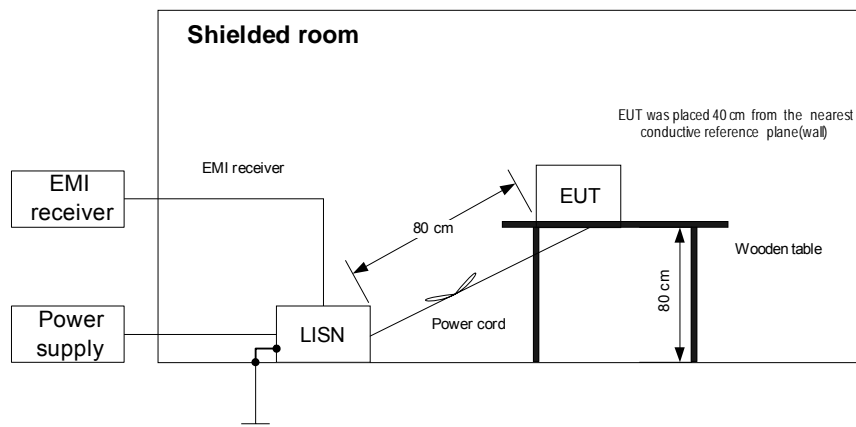



Test specification:	Section 15.107, Conducted emission at AC power port, Class A		
Test procedure:	ANSI C63.4, Sections 11.5 and 12.1.3		
Test mode:	Compliance	Verdict:	PASS
Date:	11/26/2007		
Temperature: 23 °C	Air Pressure: 1012 hPa	Relative Humidity: 46 %	Power Supply: 120 VAC
Remarks:			

Table 8.1.2 Conducted emission test results

LINE: AC mains
EUT SET UP: TABLE-TOP
TEST SITE: SHIELDED ROOM
DETECTORS USED: PEAK / QUASI-PEAK / AVERAGE
FREQUENCY RANGE: 150 kHz - 30 MHz
RESOLUTION BANDWIDTH: 9 kHz

Frequency, MHz	Peak emission, dB(μV)	Quasi-peak			Average			Line ID	Verdict
		Measured emission, dB(μV)	Limit, dB(μV)	Margin, dB*	Measured emission, dB(μV)	Limit, dB(μV)	Margin, dB*		
Transmit Mode									
0.155710	62.33	50.26	79.00	-28.74	18.44	66.00	-47.56	L1	Pass
0.182528	56.65	44.49	79.00	-34.51	9.21	66.00	-56.79		
0.189889	47.44	40.05	79.00	-38.95	7.94	66.00	-58.06		
0.191009	57.14	42.69	79.00	-36.31	7.54	66.00	-58.46		
0.248698	56.78	45.81	79.00	-33.19	12.64	66.00	-53.36		
0.158796	49.80	47.96	79.00	-31.04	15.29	66.00	-50.71	L2	Pass
0.224859	54.43	45.78	79.00	-33.22	13.11	66.00	-52.89		
Receive Mode									
0.137367	23.17	19.46	79.00	-59.54	16.21	66.00	-49.79	L1	Pass
0.226894	51.48	44.59	79.00	-34.41	12.43	66.00	-53.57		
5.908953	37.87	31.38	73.00	-41.62	21.04	60.00	-38.96		
0.228820	52.10	45.83	79.00	-33.17	13.60	66.00	-52.40	L2	Pass
5.908953	37.87	31.38	73.00	-41.62	21.04	60.00	-38.96		
PC									
0.408847	47.31	43.64	79.00	-35.36	27.17	66.00	-38.83	L1	Pass
0.225279	44.55	33.63	79.00	-45.37	29.56	66.00	-36.44	L2	Pass

*- Margin = Measured emission - specification limit.

Reference numbers of test equipment used

HL 0163	HL 0787	HL 1503					
---------	---------	---------	--	--	--	--	--

Full description is given in Appendix A.



Test specification:	Section 15.107, Conducted emission at AC power port, Class A		
Test procedure:	ANSI C63.4, Sections 11.5 and 12.1.3		
Test mode:	Compliance	Verdict:	PASS
Date:	11/26/2007		
Temperature: 23 °C	Air Pressure: 1012 hPa	Relative Humidity: 46 %	Power Supply: 120 VAC
Remarks:			

Plot 8.1.1 Conducted emission measurements on the modem AC lines

LINE: L1
LIMIT: QUASI-PEAK, AVERAGE
DETECTOR: PEAK
MODE: Transmit

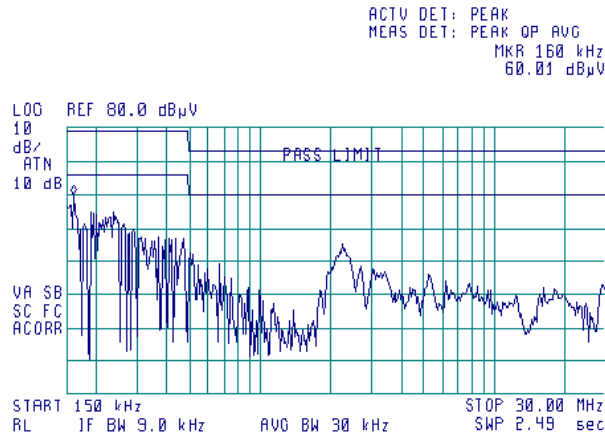

Plot 8.1.2 Conducted emission measurements on the modem AC lines

LINE: L2
LIMIT: QUASI-PEAK, AVERAGE
DETECTOR: PEAK
MODE: Transmit

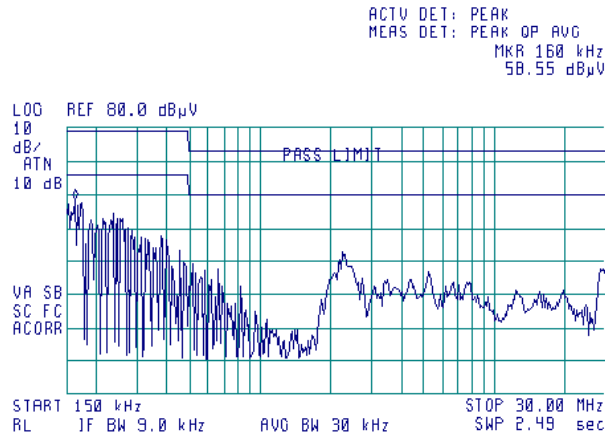



Test specification:	Section 15.107, Conducted emission at AC power port, Class A		
Test procedure:	ANSI C63.4, Sections 11.5 and 12.1.3		
Test mode:	Compliance	Verdict:	PASS
Date:	11/26/2007		
Temperature: 23 °C	Air Pressure: 1012 hPa	Relative Humidity: 46 %	Power Supply: 120 VAC
Remarks:			

Plot 8.1.3 Conducted emission measurements on the modem AC lines

LINE: L1
LIMIT: QUASI-PEAK, AVERAGE
DETECTOR: PEAK
MODE: Receive

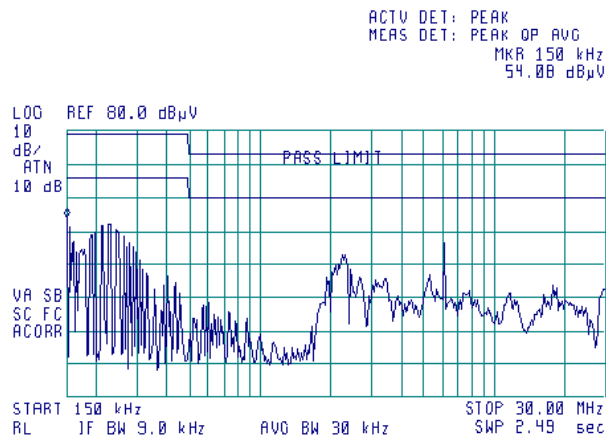

Plot 8.1.4 Conducted emission measurements on the modem AC lines

LINE: L2
LIMIT: QUASI-PEAK, AVERAGE
DETECTOR: PEAK
MODE: Receive

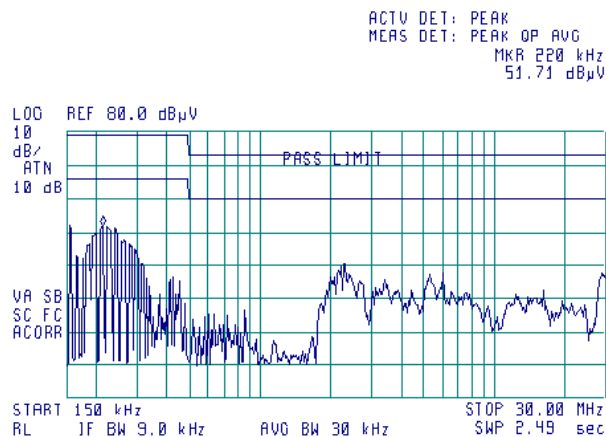



Test specification:	Section 15.107, Conducted emission at AC power port, Class A		
Test procedure:	ANSI C63.4, Sections 11.5 and 12.1.3		
Test mode:	Compliance	Verdict:	PASS
Date:	11/26/2007		
Temperature: 23 °C	Air Pressure: 1012 hPa	Relative Humidity: 46 %	Power Supply: 120 VAC
Remarks:			

Plot 8.1.5 Conducted emission measurements on PC power lines

LINE: L1
LIMIT: QUASI-PEAK, AVERAGE
DETECTOR: PEAK

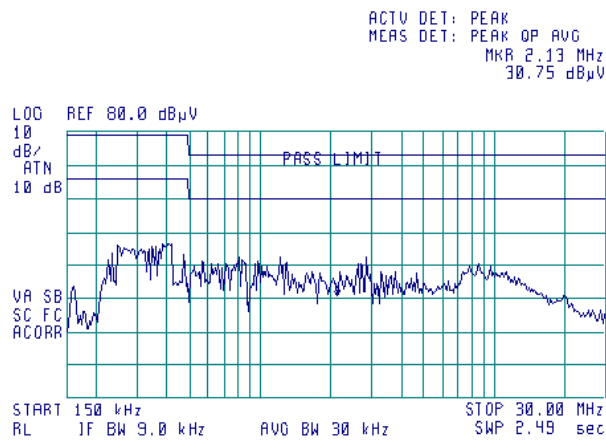

Plot 8.1.6 Conducted emission measurements on PC power lines

LINE: L2
LIMIT: QUASI-PEAK, AVERAGE
DETECTOR: PEAK

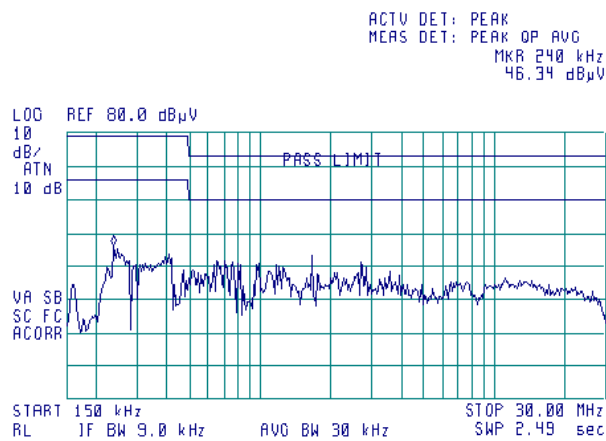

Test specification:	Section 15.109, Radiated emission, Class A		
Test procedure:	ANSI C63.4, Sections 11.6 and 12.1.4		
Test mode:	Compliance	Verdict:	PASS
Date:	11/22/2007		
Temperature: 24 °C	Air Pressure: 1016 hPa	Relative Humidity: 45 %	Power Supply: 120 VAC
Remarks:			

8.2 Radiated emission measurements

8.2.1 General

This test was performed to measure radiated emissions from the EUT enclosure. The specification test limits are given in Table 8.2.1.

Table 8.2.1 Radiated emission test limits

Frequency, MHz	Class B limit, dB(μV/m)		Class A limit, dB(μV/m)	
	10 m distance	3 m distance	10 m distance	3 m distance
30 - 88	29.5*	40.0	39.0	49.5*
88 - 216	33.0*	43.5	43.5	54.0*
216 - 960	35.5*	46.0	46.4	56.9*
Above 960	43.5*	54.0	49.5	60.0*

* - The limit for a test distance other than specified was calculated using the inverse linear distance extrapolation factor as follows: $Lim_{S_2} = Lim_{S_1} + 20 \log(S_1/S_2)$, where S_1 and S_2 – the standard defined and the test distance respectively in meters.

8.2.2 Test procedure

8.2.2.1 The EUT was set up as shown in Figure 8.2.1, energized and the EUT performance was checked.

8.2.2.2 The measurements were performed in the anechoic chamber at 3 m test distance. The specified frequency range was investigated with the antenna connected to the EMI receiver. To find the highest emission the turntable was rotated 360° and the measuring antenna height was swept from 1 to 4 m in both, vertical and horizontal polarizations. The EUT cables position was varied to maximize emission.

8.2.2.3 The worst test results with respect to the limits were recorded in Table 8.2.2 and shown in the associated plots.

Figure 8.2.1 Setup for radiated emission measurements in anechoic chamber, table-top EUT

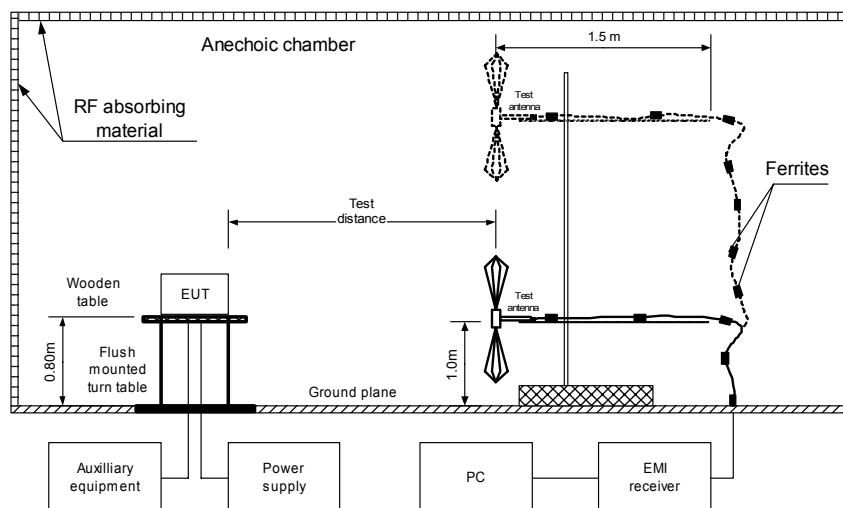



Test specification:	Section 15.109, Radiated emission, Class A		
Test procedure:	ANSI C63.4, Sections 11.6 and 12.1.4		
Test mode:	Compliance	Verdict:	PASS
Date:	11/22/2007		
Temperature: 24 °C	Air Pressure: 1016 hPa	Relative Humidity: 45 %	Power Supply: 120 VAC
Remarks:			

Table 8.2.2 Radiated emission test results

EUT SET UP: TABLE-TOP
 EUT OPERATING MODE: Receive / Standby
 TEST SITE: SEMI ANECHOIC CHAMBER
 TEST DISTANCE: 3 m
 DETECTORS USED: PEAK / QUASI-PEAK
 FREQUENCY RANGE: 30 MHz – 1000 MHz
 RESOLUTION BANDWIDTH: 120 kHz

Frequency, MHz	Peak emission, dB(µV/m)	Measured emission, dB(µV/m)	Quasi-peak		Antenna polarization	Antenna height, m	Turn-table position**, degrees	Verdict
			Limit, dB(µV/m)	Margin, dB*				
33.207500	37.81	35.60	49.50	-13.90	V	1.0	338	Pass
99.702000	49.95	45.98	54.00	-8.02	H	2.7	289	
132.560075	42.27	39.73	54.00	-14.27	H	2.0	38	
166.194100	50.73	48.92	54.00	-5.08	H	1.8	144	
199.233500	52.51	50.36	54.00	-3.64	H	1.6	139	
232.442500	39.45	36.34	57.00	-20.66	V	1.0	148	
250.004400	42.73	37.10	57.00	-19.90	H	1.0	343	

H
 TEST SITE: SEMI ANECHOIC CHAMBER
 TEST DISTANCE: 3 m
 DETECTORS USED: PEAK / AVERAGE
 FREQUENCY RANGE: 1000 MHz – 8000 MHz
 RESOLUTION BANDWIDTH: 1000 kHz

Frequency, MHz	Peak emission, dB(µV/m)	Average			Antenna polarization	Antenna height, m	Turn-table position**, degrees	Verdict
		Measured emission, dB(µV/m)	Limit, dB(µV/m)	Margin, dB*				
No emissions were found								Pass

*- Margin = Measured emission - specification limit.
 **- EUT front panel refers to 0 degrees position of turntable.

Reference numbers of test equipment used

HL 0521	HL 0589	HL 0604	HL 1004	HL 1947	HL 2009	HL 2259	HL 2432
HL 2780	HL 2871						

Full description is given in Appendix A.



Test specification:	Section 15.109, Radiated emission, Class A		
Test procedure:	ANSI C63.4, Sections 11.6 and 12.1.4		
Test mode:	Compliance	Verdict:	PASS
Date:	11/22/2007		
Temperature: 24 °C	Air Pressure: 1016 hPa	Relative Humidity: 45 %	Power Supply: 120 VAC
Remarks:			

Plot 8.2.1 Radiated emission measurements in 30- 1000 MHz range, vertical antenna polarization

TEST SITE: Semi anechoic chamber
 TEST DISTANCE: 3 m
 EUT OPERATING MODE: Receive / Standby

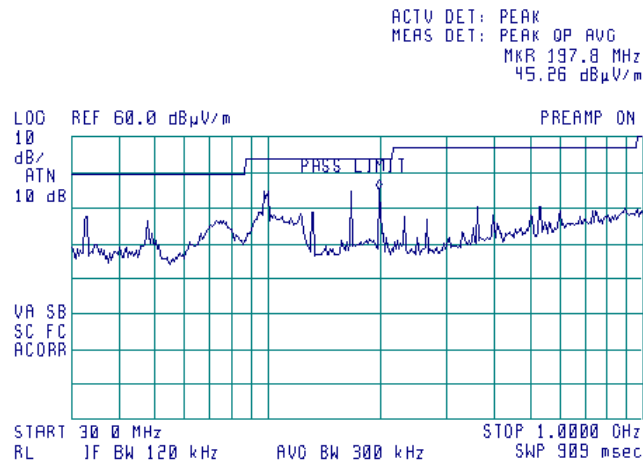

Plot 8.2.2 Radiated emission measurements in 30- 1000 MHz range, horizontal antenna polarization

TEST SITE: Semi anechoic chamber
 TEST DISTANCE: 3 m
 EUT OPERATING MODE: Receive / Standby

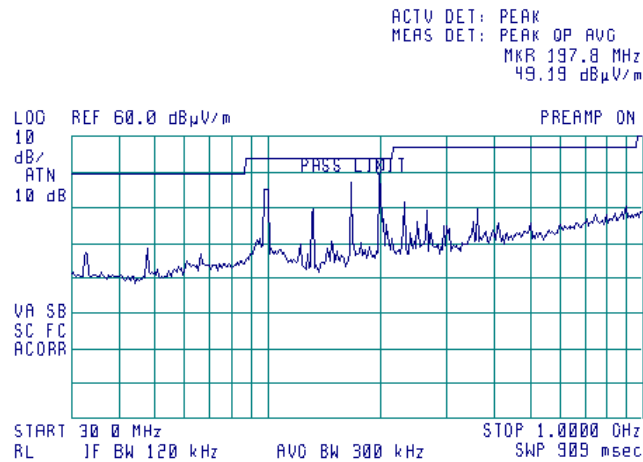



Test specification:	Section 15.109, Radiated emission, Class A		
Test procedure:	ANSI C63.4, Sections 11.6 and 12.1.4		
Test mode:	Compliance	Verdict:	PASS
Date:	11/22/2007		
Temperature: 24 °C	Air Pressure: 1016 hPa	Relative Humidity: 45 %	Power Supply: 120 VAC
Remarks:			

Plot 8.2.3 Radiated emission measurements in 1.0 – 2.9 GHz range, vertical antenna polarization

TEST SITE: Semi anechoic chamber
 TEST DISTANCE: 3 m
 EUT OPERATING MODE: Receive / Standby

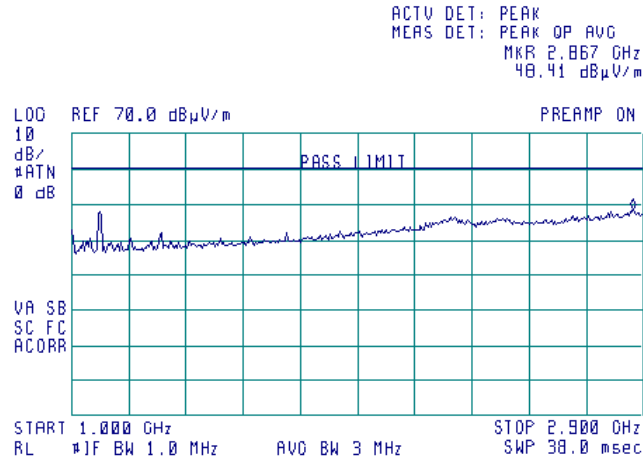

Plot 8.2.4 Radiated emission measurements in 1.0 – 2.9 GHz range, horizontal antenna polarization

TEST SITE: Semi anechoic chamber
 TEST DISTANCE: 3 m
 EUT OPERATING MODE: Receive / Standby

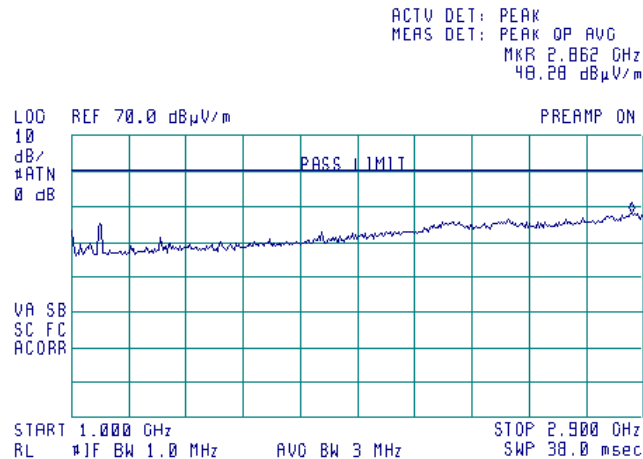



Test specification:	Section 15.109, Radiated emission, Class A		
Test procedure:	ANSI C63.4, Sections 11.6 and 12.1.4		
Test mode:	Compliance	Verdict:	PASS
Date:	11/22/2007		
Temperature: 24 °C	Air Pressure: 1016 hPa	Relative Humidity: 45 %	Power Supply: 120 VAC
Remarks:			

Plot 8.2.5 Radiated emission measurements in 2.9 – 8.0 GHz range, vertical antenna polarization

TEST SITE: Semi anechoic chamber
TEST DISTANCE: 3 m
EUT OPERATING MODE: Receive / Standby

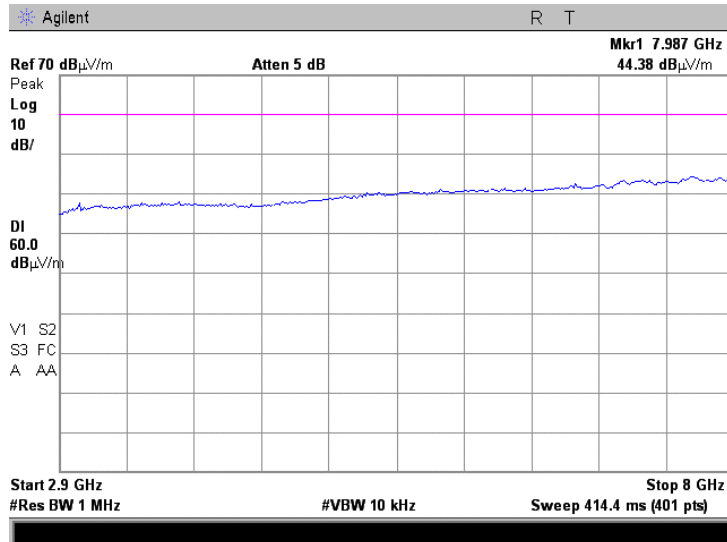
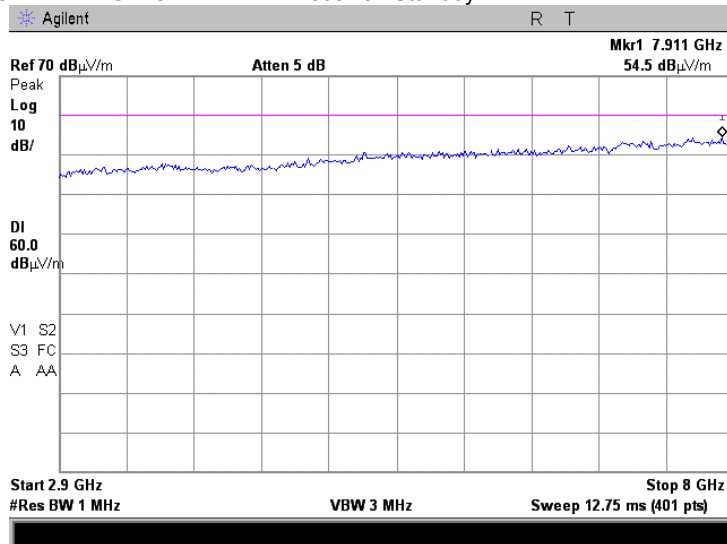



Test specification:	Section 15.109, Radiated emission, Class A		
Test procedure:	ANSI C63.4, Sections 11.6 and 12.1.4		
Test mode:	Compliance	Verdict:	PASS
Date:	11/22/2007		
Temperature: 24 °C	Air Pressure: 1016 hPa	Relative Humidity: 45 %	Power Supply: 120 VAC
Remarks:			

Plot 8.2.6 Radiated emission measurements in 2.9 – 8.0GHz range, horizontal antenna polarization

TEST SITE: Semi anechoic chamber
TEST DISTANCE: 3 m
EUT OPERATING MODE: Receive / Standby

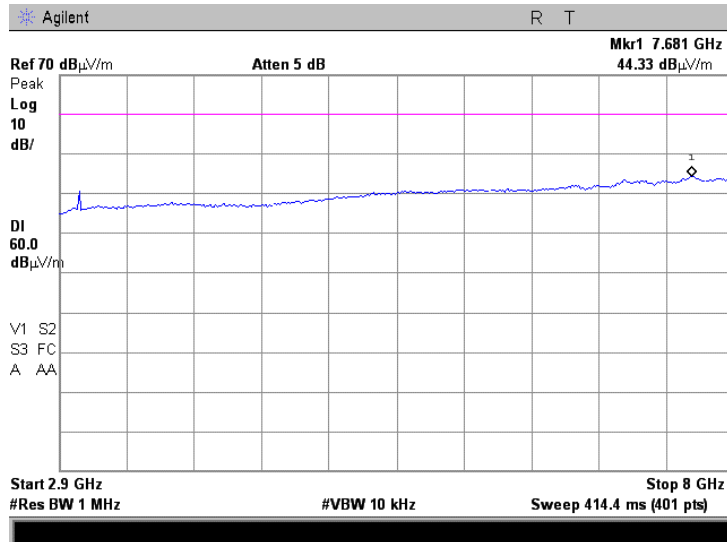
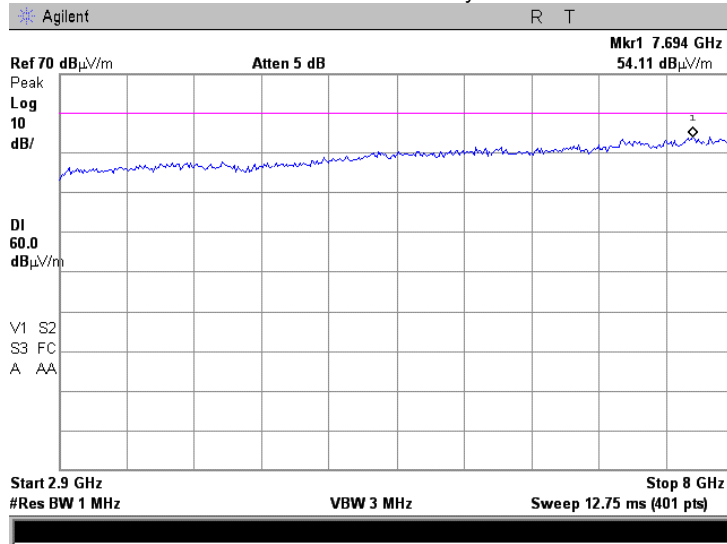

Test specification:	Section 15.111, Conducted emission at receiver antenna port		
Test procedure:	ANSI C63.4, Section 12.1.5		
Test mode:	Compliance	Verdict:	PASS
Date:	11/27/2007		
Temperature: 23 °C	Air Pressure: 1013 hPa	Relative Humidity: 48 %	Power Supply: 120 VAC
Remarks:			

8.3 Antenna power conducted measurements for receiver

8.3.1 General

This test was performed to measure spurious emissions at RF antenna connector of receiver operated within 30 to 960 MHz band which was tested for compliance with radiated emission limits with the antenna port connected to resistive termination. The specification test limits are given in Table 8.3.1.

Table 8.3.1 Spurious emission limits

Frequency, MHz	EUT type	Power of spurious	
		nW	dBm
30 MHz – 2 nd harmonic*	Superheterodyne receiver	2.0	-57.0

* - harmonic of the local oscillator frequency.

8.3.2 Test procedure

8.3.2.1 The EUT was set up as shown in Figure 8.3.1, energized and its proper operation was checked.

8.3.2.2 The spurious emission was measured with spectrum analyzer as provided in Table 8.3.2 and associated plots.

Figure 8.3.1 Spurious emission test setup

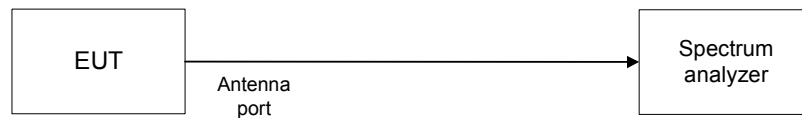



Test specification:	Section 15.111, Conducted emission at receiver antenna port		
Test procedure:	ANSI C63.4, Section 12.1.5		
Test mode:	Compliance	Verdict:	PASS
Date:	11/27/2007		
Temperature: 23 °C	Air Pressure: 1013 hPa	Relative Humidity: 48 %	Power Supply: 120 VAC
Remarks:			

Table 8.3.2 Spurious emission test results

INVESTIGATED FREQUENCY RANGE: 30 – 2000 MHz
 RECEIVER TYPE: Superheterodyne
 EUT OPERATING MODE: Receive
 DETECTOR USED: Peak
 RESOLUTION BANDWIDTH: 1000 kHz
 VIDEO BANDWIDTH: 3000 kHz

Frequency, MHz	Spurious emission, dBm	Limit, dBm	Margin, dB	Verdict
97.90	-69.67	-57.0	-12.67	Pass
447.1	-66.17		-9.17	Pass
788.2	-71.00		-14.00	Pass
848.0	-68.17		-11.17	Pass
899.8	-66.50		-9.50	Pass
1200.0	-68.67		-11.67	Pass
1250.0	-69.17		-12.17	Pass
1353.0	-69.67		-12.67	Pass
1400.0	-70.17		-13.17	Pass
1497.0	-68.67		-11.67	Pass

Reference numbers of test equipment used

HL 1424	HL 2869						
---------	---------	--	--	--	--	--	--

Full description is given in Appendix A.



Test specification:	Section 15.111, Conducted emission at receiver antenna port		
Test procedure:	ANSI C63.4, Section 12.1.5		
Test mode:	Compliance	Verdict:	PASS
Date:	11/27/2007		
Temperature: 23 °C	Air Pressure: 1013 hPa	Relative Humidity: 48 %	Power Supply: 120 VAC
Remarks:			

Plot 8.3.1 Spurious emission measurements in 30 to 1000 MHz range

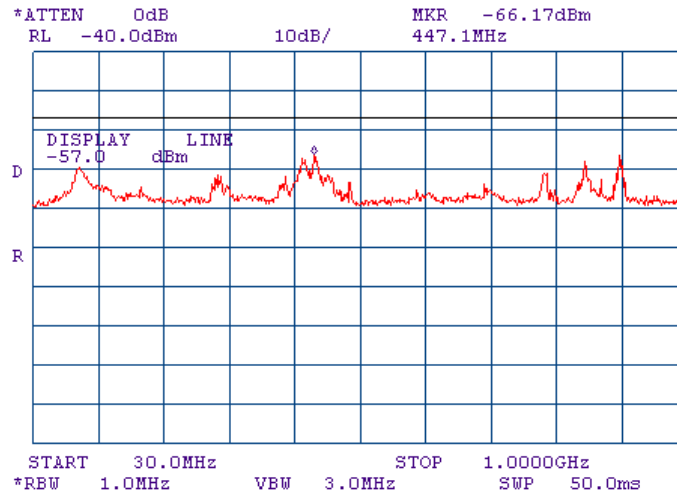

Plot 8.3.2 Spurious emission measurements in 1000 to 2000 MHz range

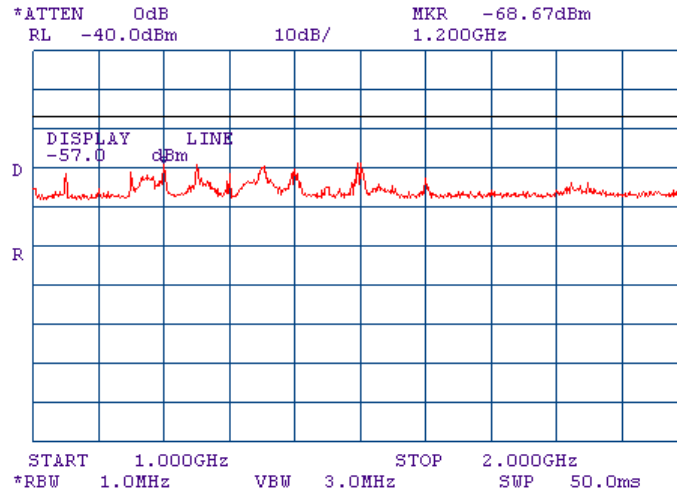

**9 APPENDIX A Test equipment and ancillaries used for tests**

HL No	Description	Manufacturer	Model	Ser. No.	Last Cal.	Due Cal.
0163	LISN FCC/VDE/50 Ohm/50 uH + 5 Ohm, MIL-STD-461E, CISPR 16-1	Electro-Metrics	ANS 25/2	1314	20-Nov-07	20-Nov-08
0415	Cable, Coax, RF, RG-214	HL	CC-3	056	02-Dec-07	02-Dec-08
0446	Antenna, Loop, Active, 10 kHz - 30 MHz	EMCO	6502	2857	28-Jun-07	28-Jun-08
0493	Temperature Chamber -45...175 deg C	Thermotron	S-1.2 Mini-Max	14016	08-Mar-07	08-Mar-08
0521	EMI Receiver (Spectrum Analyzer) with RF filter section 9 kHz-6.5 GHz	Hewlett Packard Co	8546A	3617A 00319, 3448A002 53	28-Aug-07	28-Aug-08
0589	Cable Coaxial, GORE A2P01POL118, 2.3 m	HL	GORE-3	176	02-Dec-07	02-Dec-08
0604	Antenna BiconiLog Log-Periodic/T Bow-TIE, 26 - 2000 MHz	EMCO	3141	9611-1011	10-Jan-08	10-Jan-09
0661	Generator Swept Signal, 10 MHz to 40 GHz, + 10 dBm	HP	83640B	3614A002 66	23-Sep-07	23-Sep-08
0787	Transient Limiter 9 kHz-200 MHz	Hewlett Packard Co	11947A	3107A018 77	21-Nov-07	21-Nov-08
0812	Cable Coax, RG-214, 11.5 m, N-type connectors	HL	C214-11	148	02-Dec-07	02-Dec-08
1004	Cable Coaxial , ANDREW PSWJ4 , 6m	HL	ANDREW -6	163	02-Dec-07	02-Dec-08
1424	Spectrum Analyzer, 30 Hz- 40 GHz	Agilent Technologies	8564EC	3946A002 19	28-Aug-07	28-Aug-08
1430	EMI Receiver, 9 kHz - 2.9 GHz, System: HL1431, HL1432	Agilent Technologies	8542E	3807A002 62,3705A0 0217	31-Aug-07	31-Aug-08
1503	Cable RF, 6 m, BNC/BNC	Belden	M17/167 MIL-C-17	1503	11-Sep-07	11-Sep-08
1947	Cable 18GHz, 6.5 m, blue	Rhophase Microwave Limited	NPS-1803A-6500-NPS	T4974	05-Oct-07	05-Oct-08
2009	Cable RF, 8 m	Alpha Wire	RG-214	C-56	01-Jan-08	01-Jan-09
2011	Power Divider, 0.5-18.0 GHz, 80 W	Omni Spectra	2090-6204-00	2011	05-Dec-07	05-Dec-08
2259	Amplifier Low Noise 2-20 GHz	Sophia Wireless	LNA0220-C	0223	05-Nov-07	05-Nov-08
2432	Antenna, Double-Ridged Waveguide Horn 1-18 GHz	EMC Test Systems	3115	00027177	03-Mar-07	03-Mar-08
2780	EMC analyzer, 100 Hz to 26.5 GHz	Agilent Technologies	E7405A	MY451024 6	11-Jun-07	11-Jun-08
2867	Cable, 18 GHz, 0.9 m, SMA - SMA, Right Angle	Gore	NA	91P72076	11-Feb-07	11-Feb-08
2869	Cable, 18 GHz, 1.2 m, SMA - SMA, Right Angle	Gore	NA	91P72073	11-Feb-07	11-Feb-08
2871	Microwave Cable Assembly, 18 GHz, 6.4 m, SMA - SMA	Huber-Suhner	198-8155-00	2871	11-Feb-07	11-Feb-08
2909	Spectrum analyzer, ESA-E, 100 Hz to 26.5 GHz	Agilent Technologies	E4407B	MY414447 62	07-May-07	07-May-08
2976	Fieldmeter with EF2 isotropic probe (100kHz-2.5GHz) & electric field probe (0.1V/m-200V/m),supplied in a carrying case.	CHAUVIN ARNOUX	C.A 43	2976	28-Jun-07	28-Jun-08



HL No	Description	Manufacturer	Model	Ser. No.	Last Cal.	Due Cal.
3175	Attenuator, N-type, 10 dB, DC to 18 GHz, 5 W	Mini-Circuits	BW-N10W5+	0708	07-May-07	07-May-08
3180	Attenuator, N-type, 20 dB, DC to 18 GHz, 5 W	Mini-Circuits	BW-N20W5+	0651	07-May-07	07-May-08
3301	Power Meter, P-series, 50 MHz to 40 GHz	Agilent Technologies	N1911A	MY45101057	27-Jul-07	27-Jul-08
3334	Filter, High Pass, 2.5 GHz	LORCH MICROWAVE	5HP7-2500-SR	Z22	07-Oct-07	07-Oct-08
3340	High Pass Filter, 50 Ohm, 1000 to 3000 MHz.	Mini-Circuits	SHP-1000+	NA	24-Oct-07	24-Oct-08

10 APPENDIX B Measurement uncertainties

Expanded uncertainty at 95% confidence in Hermon Labs EMC measurements

Test description	Expanded uncertainty
Transmitter tests	
Carrier power conducted at antenna connector	± 1.7 dB
Carrier power radiated (substitution method)	± 4.5 dB
Occupied bandwidth	±8%
Conducted emissions at RF antenna connector	9 kHz to 2.9 GHz: ± 2.6 dB 2.9 GHz to 6.46 GHz: ± 3.5 dB 6.46 GHz to 13.2 GHz: ± 4.3 dB 13.2 GHz to 22.0 GHz: ± 5.0 dB 22.0 GHz to 26.8 GHz: ± 5.5 dB 26.8 GHz to 40.0 GHz: ± 4.8 dB
Spurious emissions radiated 30 MHz – 40 GHz (substitution method)	± 4.5 dB
Frequency stability	± 168 Hz (0.56 ppm)
Unintentional radiator tests	
Conducted emissions with LISN	9 kHz to 150 kHz: ± 3.9 dB 150 kHz to 30 MHz: ± 3.8 dB
Radiated emissions at 3 m measuring distance Horizontal polarization	Biconilog antenna: ± 5.3 dB Biconical antenna: ± 5.0 dB Log periodic antenna: ± 5.3 dB
Vertical polarization	Double ridged horn antenna: ± 5.3 dB Biconilog antenna: ± 6.0 dB Biconical antenna: ± 5.7 dB Log periodic antenna: ± 6.0 dB Double ridged horn antenna: ± 6.0 dB

Hermon Laboratories is accredited by A2LA for calibration according to present requirements of ISO/IEC 17025 and NCSL Z540-1. The accreditation is granted to perform calibration of parameters that are listed in the Scope of Hermon Laboratories Accreditation.

Hermon Laboratories calibrates its reference and transfer standards by calibration laboratories accredited to ISO/IEC 17025 by a mutually recognized Accreditation Body or by a recognized national metrology institute. All reference and transfer standards used in the calibration system are traceable to national or international standards.

In-house calibration of all test and measurement equipment is performed on a regular basis according to Hermon Laboratories calibration procedures, manufacturer calibration/verification procedures or procedures defined in the relevant standards. The Hermon Laboratories test and measurement equipment is calibrated within the tolerances specified by the manufacturers and/or by the relevant standards.

11 APPENDIX C Test laboratory description

Tests were performed at Hermon Laboratories Ltd., which is a fully independent, private, EMC, safety, environmental and telecommunication testing facility. Hermon Laboratories is listed by the Federal Communications Commission (USA) for all parts of Code of Federal Regulations 47 (CFR 47) and by Industry Canada for electromagnetic emissions (file numbers IC 2186-1 for OATS and IC 2186-2 for anechoic chamber), certified by VCCI, Japan (the registration numbers are R-808 for OATS, R-1082 for anechoic chamber, C-845 for conducted emissions site), assessed by TNO Certification EP&S (Netherlands) for a number of EMC, telecommunications, environmental, safety standards, and by AMTAC (UK) for safety of medical devices. The laboratory is accredited by American Association for Laboratory Accreditation (USA) according to ISO/IEC 17025 for electromagnetic compatibility, product safety, telecommunications testing and environmental simulation (for exact scope please refer to Certificate No. 839.01).

Address: P.O. Box 23, Binyamina 30500, Israel.
Telephone: +972 4628 8001
Fax: +972 4628 8277
e-mail: mail@hermonlabs.com
website: www.hermonlabs.com

Person for contact: Mr. Alex Usoskin, CEO.

12 APPENDIX D Specification references

47CFR part 27: 2007	Miscellaneous wireless communications services
47CFR part 1: 2006	Practice and procedure
47CFR part 2: 2006	Frequency allocations and radio treaty matters; general rules and regulations
47CFR part 15 subpart B: 2006	Radio Frequency Devices
ANSI C63.2: 1996	American National Standard for Instrumentation-Electromagnetic Noise and Field Strength, 10 kHz to 40 GHz-Specifications.
ANSI C63.4: 2003	American National Standard for Methods of Measurement of Radio-Noise Emissions from Low-Voltage Electrical and Electronic Equipment in the Range of 9 kHz to 40 GHz.
ANSI/TIA/EIA-603-C:2004	Land Mobile FM or PM Communications Equipment Measurement and Performance Standards

13 APPENDIX E Test equipment correction factors

**Correction factor
 Line impedance stabilization network
 Model ANS-25/2, Electro-Metrics, HL 0163**

Frequency, kHz	Correction factor, dB
10	4.9
15	2.86
20	1.83
25	1.25
30	0.91
35	0.69
40	0.53
50	0.35
60	0.25
70	0.18
80	0.14
90	0.11
100	0.09
125	0.06
150	0.04

The correction factor in dB is to be added to meter readings of an interference analyzer or a spectrum analyzer.



Antenna Factor
Active Loop Antenna
EMC Test Systems, model 6502, serial number 2857, HL 0446

Frequency, MHz	Magnetic Antenna Factor, dB(S/m)	Electric Antenna Factor, dB(1/m)
0.009	-32.8	18.7
0.010	-33.8	17.7
0.020	-38.3	13.2
0.050	-41.1	10.4
0.075	-41.3	10.2
0.100	-41.6	9.9
0.150	-41.7	9.8
0.250	-41.6	9.9
0.500	-41.8	9.7
0.750	-41.9	9.6
1.000	-41.4	10.1
2.000	-41.5	10.0
3.000	-41.4	10.1
4.000	-41.4	10.1
5.000	-41.5	10.0
10.000	-41.9	9.6
15.000	-41.9	9.6
20.000	-42.2	9.3
25.000	-42.8	8.7
30.000	-44.0	7.5

Antenna factor in dB(S/m) is to be added to receiver meter reading in dB(μ V) to convert it into field intensity in dB(μ A/m).
Antenna factor in dB(1/m) is to be added to receiver meter reading in dB(μ V) to convert it into field intensity in dB(μ V/m).

Antenna factor

Biconilog antenna EMCO, model 3141, serial number 1011, HL 0604

Frequency, MHz	Antenna factor, dB(1/m)	Frequency, MHz	Antenna factor, dB(1/m)	Frequency, MHz	Antenna factor, dB(1/m)
26	7.8	560	19.8	1300	27.0
28	7.8	580	20.6	1320	27.8
30	7.8	600	21.3	1340	28.3
40	7.2	620	21.5	1360	28.2
60	7.1	640	21.2	1380	27.9
70	8.5	660	21.4	1400	27.9
80	9.4	680	21.9	1420	27.9
90	9.8	700	22.2	1440	27.8
100	9.7	720	22.2	1460	27.8
110	9.3	740	22.1	1480	28.0
120	8.8	760	22.3	1500	28.5
130	8.7	780	22.6	1520	28.9
140	9.2	800	22.7	1540	29.6
150	9.8	820	22.9	1560	29.8
160	10.2	840	23.1	1580	29.6
170	10.4	860	23.4	1600	29.5
180	10.4	880	23.8	1620	29.3
190	10.3	900	24.1	1640	29.2
200	10.6	920	24.1	1660	29.4
220	11.6	940	24.0	1680	29.6
240	12.4	960	24.1	1700	29.8
260	12.8	980	24.5	1720	30.3
280	13.7	1000	24.9	1740	30.8
300	14.7	1020	25.0	1760	31.1
320	15.2	1040	25.2	1780	31.0
340	15.4	1060	25.4	1800	30.9
360	16.1	1080	25.6	1820	30.7
380	16.4	1100	25.7	1840	30.6
400	16.6	1120	26.0	1860	30.6
420	16.7	1140	26.4	1880	30.6
440	17.0	1160	27.0	1900	30.6
460	17.7	1180	27.0	1920	30.7
480	18.1	1200	26.7	1940	30.9
500	18.5	1220	26.5	1960	31.2
520	19.1	1240	26.5	1980	31.6
540	19.5	1260	26.5	2000	32.0
		1280	26.6		

Antenna factor in dB(1/m) is to be added to receiver meter reading in dB(μ V) to convert it into field intensity in dB(μ V/m).

**Antenna factor
Double-ridged guide horn antenna
Model 3115, serial number: 00027177, HL 2432**

Frequency, MHz	Antenna factor. dB(1/m)
1000.0	24.7
1500.0	25.7
2000.0	27.8
2500.0	28.9
3000.0	30.7
3500.0	31.8
4000.0	33.0
4500.0	32.8
5000.0	34.2
5500.0	34.9
6000.0	35.2
6500.0	35.4
7000.0	36.3
7500.0	37.3
8000.0	37.5
8500.0	38.0
9000.0	38.3
9500.0	38.3
10000.0	38.7
10500.0	38.7
11000.0	38.9
11500.0	39.5
12000.0	39.5
12500.0	39.4
13000.0	40.5
13500.0	40.8
14000.0	41.5
14500.0	41.3
15000.0	40.2
15500.0	38.7
16000.0	38.5
16500.0	39.8
17000.0	41.9
17500.0	45.8
18000.0	49.1

Antenna factor in dB(1/m) is to be added to receiver meter reading in dB(μ V) to convert it into field intensity in dB(μ V/m).



Cable loss

Cable coaxial, GORE A2P01POL118, 2.3 m, model GORE-3, serial number 176, HL 0589
+ Cable coaxial, ANDREW PSWJ4, 6 m, model: ANDREW-6, serial number 163, HL 1004

No.	Frequency, MHz	Cable loss, dB	Tolerance (Specification), dB	Measurement uncertainty, dB
1	30	0.33	≤ 6.5	±0.12
2	50	0.40		
3	100	0.57		
4	300	0.97		
5	500	1.25		
6	800	1.59		
7	1000	1.81		
8	1200	1.97		
9	1400	2.15		
10	1600	2.28		
11	1800	2.43		
12	2000	2.61		
13	2200	2.75		
14	2400	2.89		
15	2600	2.97		
16	2800	3.21	≤ 6.5	±0.12
17	3000	3.32		
18	3300	3.47		
19	3600	3.62		
20	3900	3.84		
21	4200	3.92		
22	4500	4.07		
23	4800	4.36		
24	5100	4.62		
25	5400	4.78		
26	5700	5.16		
27	6000	5.67		
28	6500	5.99		±0.17



Cable loss
Cable Coaxial, RG-58/RG-214, s/n 056, HL 0415
+ Cable Coaxial, RG-214, 11.5m, s/n 148, HL 0812

No.	Frequency, MHz	Cable loss, dB	Measured uncertainty, dB
1	20	0.73	±0.12
2	30	0.91	
3	50	1.2	
4	80	1.56	
5	100	1.76	
6	200	2.59	
7	300	3.26	
8	400	3.93	
9	500	4.42	
10	600	4.92	
11	700	5.36	
12	800	5.88	
13	900	6.41	
14	1000	6.71	
15	1500	8.63	
16	2000	10.39	

Cable loss
Cable coaxial, 6 m, model: M17/167 MIL-C-17, HL 1503

Frequency, MHz	Cable loss, dB
0.15	0.043
1	0.077
3	0.139
5	0.169
10	0.248
30	0.430
50	0.561
75	0.697
100	0.822
300	1.446
500	1.901
800	2.663
1000	2.829
1500	3.569
2000	4.179

Cable loss
Cable M17/167 MIL-C-17, HL 1510

No.	Frequency, MHz	Cable loss, dB
1	0.1	0.05
2	1	0.09
3	3	0.16
4	5	0.18
5	10	0.27
6	30	0.44
7	50	0.58
8	80	0.69
9	100	0.82
10	300	1.48
11	500	2.01
12	800	2.65
13	1000	3.12

Cable loss
Cable 18 GHz, 6.5 m, blue, model NPS-1803A-6500-NPS, serial number T4974, HL 1947

Frequency, GHz	Insertion loss, dB
0.03	0.30
0.05	0.38
0.10	0.53
0.20	0.74
0.30	0.91
0.40	1.05
0.50	1.18
0.60	1.29
0.70	1.40
0.80	1.50
0.90	1.59
1.00	1.68
1.10	1.77
1.20	1.86
1.30	1.94
1.40	2.01
1.50	2.08
1.60	2.16
1.70	2.22
1.80	2.29
1.90	2.36
2.00	2.42
2.10	2.48
2.20	2.54
2.30	2.60
2.40	2.66
2.50	2.71
2.60	2.77
2.70	2.83
2.80	2.89
2.90	2.95
3.10	3.06
3.30	3.17
3.50	3.28
3.70	3.39
3.90	3.51
4.10	3.62
4.30	3.76
4.50	3.87
4.70	4.01
4.90	4.10
5.10	4.21
5.30	4.31
5.50	4.43
5.70	4.56
5.90	4.71

Frequency, GHz	Insertion loss, dB
6.10	4.87
6.30	4.95
6.50	4.94
6.70	4.88
6.90	4.87
7.10	4.83
7.30	4.85
7.50	4.86
7.70	4.91
7.90	4.96
8.10	5.03
8.30	5.08
8.50	5.13
8.70	5.21
8.90	5.22
9.10	5.34
9.30	5.35
9.50	5.52
9.70	5.51
9.90	5.66
10.10	5.70
10.30	5.78
10.50	5.79
10.70	5.82
10.90	5.86
11.10	5.94
11.30	6.06
11.50	6.21
11.70	6.44
11.90	6.61
12.10	6.76
12.40	6.68
13.00	6.66
13.50	6.81
14.00	6.90
14.50	6.90
15.00	6.97
15.50	7.17
16.00	7.28
16.50	7.27
17.00	7.38
17.50	7.68
18.00	7.92



Cable loss
RF cable 8 m, model RG-214, serial number C-56, HL 2009

No.	Frequency, MHz	Cable loss, dB	Tolerance (Specification), dB	Measurement uncertainty, dB
1	1	0.10	NA	±0.12
2	10	0.14		
3	30	0.25		
4	50	0.34		
5	100	0.53		
6	300	0.99		
7	500	1.31		
8	800	1.73		
9	1000	1.98		
10	1100	2.11		
11	1200	2.21		
12	1300	2.35		
13	1400	2.46		
14	1500	2.55		
15	1600	2.68		
16	1700	2.78		
17	1800	2.88		
18	1900	2.98		
19	2000	3.09		



Cable loss
Cable coaxial, Gore, 18 GHz, 0.9 m, SMA - SMA, model Right Angle, S/N 91P72076
HL 2867

Frequency, GHz	Cable loss, dB	Frequency, GHz	Cable loss, dB	Frequency, GHz	Cable loss, dB
10	0.06	5750	0.68	12000	1.06
30	0.04	6000	0.69	12250	1.07
100	0.07	6250	0.70	12500	1.09
250	0.14	6500	0.73	12750	1.09
500	0.19	6750	0.74	13000	1.15
750	0.22	7000	0.78	13250	1.17
1000	0.26	7250	0.77	13500	1.16
1250	0.27	7500	0.79	13750	1.17
1500	0.31	7750	0.81	14000	1.14
1750	0.35	8000	0.86	14250	1.13
2000	0.38	8250	0.86	14500	1.06
2250	0.41	8500	0.87	14750	1.12
2500	0.43	8750	0.87	15000	1.16
2750	0.46	9000	0.88	15250	1.11
3000	0.48	9250	0.89	15500	1.06
3250	0.51	9500	0.90	15750	1.12
3500	0.53	9750	0.94	16000	1.20
3750	0.55	10000	1.00	16250	1.25
4000	0.56	10250	1.01	16500	1.24
4250	0.58	10500	1.02	16750	1.34
4500	0.60	10750	1.01	17000	1.35
4750	0.62	11000	1.01	17250	1.35
5000	0.52	11250	1.01	17500	1.36
5250	0.67	11500	1.01	17750	1.40
5500	0.68	11750	1.05	18000	1.51



Cable loss
Cable coaxial, Gore, 18 GHz, 1.1 m, SMA - SMA, model Right Angle, S/N 91P72071
HL 2869

Frequency, GHz	Cable loss, dB	Frequency, GHz	Cable loss, dB	Frequency, GHz	Cable loss, dB
10	0.06	5750	0.87	12000	1.30
30	0.06	6000	0.87	12250	1.33
100	0.10	6250	0.89	12500	1.35
250	0.18	6500	0.92	12750	1.36
500	0.25	6750	0.94	13000	1.38
750	0.27	7000	0.98	13250	1.41
1000	0.34	7250	0.99	13500	1.39
1250	0.35	7500	1.02	13750	1.41
1500	0.42	7750	1.03	14000	1.42
1750	0.44	8000	1.04	14250	1.46
2000	0.49	8250	1.04	14500	1.39
2250	0.52	8500	1.08	14750	1.46
2500	0.55	8750	1.08	15000	1.40
2750	0.59	9000	1.12	15250	1.47
3000	0.61	9250	1.12	15500	1.36
3250	0.52	9500	1.15	15750	1.49
3500	0.67	9750	1.14	16000	1.51
3750	0.69	10000	1.19	16250	1.60
4000	0.70	10250	1.20	16500	1.56
4250	0.74	10500	1.23	16750	1.66
4500	0.76	10750	1.24	17000	1.71
4750	0.77	11000	1.24	17250	1.78
5000	0.79	11250	1.25	17500	1.75
5250	0.82	11500	1.040	17750	1.77
5500	0.84	11750	1.29	18000	1.86

Cable loss
Cable coaxial, Huber-Suhner, 18 GHz, 6.4 m, SMA - SMA, model 198-8155-00,
HL 2871

Frequency, MHz	Cable loss, dB	Frequency, MHz	Cable loss, dB	Frequency, MHz	Cable loss, dB
10	0.12	5750	2.34	12000	3.55
30	0.14	6000	2.39	12250	3.61
100	0.27	6250	2.46	12500	3.67
250	0.45	6500	2.52	12750	3.74
500	0.63	6750	2.58	13000	3.79
750	0.76	7000	2.64	13250	3.82
1000	0.89	7250	2.68	13500	3.83
1250	1.01	7500	2.73	13750	3.83
1500	1.12	7750	2.78	14000	3.88
1750	1.23	8000	2.83	14250	3.93
2000	1.32	8250	2.88	14500	3.96
2250	1.41	8500	2.94	14750	4.01
2500	1.49	8750	2.97	15000	4.00
2750	1.58	9000	3.02	15250	4.01
3000	1.66	9250	3.07	15500	4.00
3250	1.73	9500	3.13	15750	4.13
3500	1.80	9750	3.18	16000	4.22
3750	1.87	10000	3.21	16250	4.29
4000	1.93	10250	3.26	16500	4.29
4250	2.01	10500	3.30	16750	4.32
4500	2.06	10750	3.36	17000	4.37
4750	2.12	11000	3.39	17250	4.45
5000	2.17	11250	3.44	17500	4.49
5250	2.24	11500	3.48	17750	4.53
5500	2.29	11750	3.52	18000	4.55

14 APPENDIX F Abbreviations and acronyms

A	ampere
AC	alternating current
A/m	ampere per meter
AM	amplitude modulation
AVRG	average (detector)
cm	centimeter
dB	decibel
dBm	decibel referred to one milliwatt
dB(μ V)	decibel referred to one microvolt
dB(μ V/m)	decibel referred to one microvolt per meter
dB(μ A)	decibel referred to one microampere
DC	direct current
EIRP	equivalent isotropically radiated power
ERP	effective radiated power
EUT	equipment under test
F	frequency
GHz	gigahertz
GND	ground
H	height
HL	Hermon laboratories
Hz	hertz
ITE	information technology equipment
k	kilo
kHz	kilohertz
LISN	line impedance stabilization network
LO	local oscillator
m	meter
MHz	megahertz
min	minute
mm	millimeter
ms	millisecond
μ s	microsecond
NA	not applicable
OATS	open area test site
Ω	Ohm
QP	quasi-peak
PCB	printed circuit board
PM	pulse modulation
PS	power supply
RE	radiated emission
RF	radio frequency
rms	root mean square
Rx	receive
s	second
T	temperature
Tx	transmit
V	volt