



DX Series

INSTRUCTION MANUAL

Digital QAM Upconverter

Complete Units

Model		Stock No.
DX-1	(Single Channel Complete Unit)	2632-1
DX-2	(Two Channel Complete Unit)	2632-2
DX-3	(Three Channel Complete Unit)	2632-3
DX-4	(Four Channel Complete Unit)	2632-4

Components

Model		Stock No.
DX-SXM	(Single Upconverter Module)	2621
DX-PSCM	(Power Supply & Control Module)	2622
DX-4XCH	(Four Upconverter Chassis)	2632



DX Instruction Manual

The lightning bolt with an electrical symbol within an equilateral triangle is intended to alert you to the presence of unisolated "dangerous voltage" within the product's enclosure that may be of sufficient magnitude to constitute a risk of electrical shock to persons.



CAUTION
RISK OF ELECTRIC SHOCK
DO NOT OPEN



The exclamation point within an equilateral triangle is intended to alert you to the presence of important operating and maintenance (servicing) instructions in the literature accompanying the product.

TO REDUCE THE RISK OF ELECTRICAL SHOCK, DO NOT REMOVE COVER FROM THIS UNIT. NO USER-SERVICEABLE PARTS INSIDE. REFER SERVICING TO QUALIFIED SERVICE PERSONNEL.

WARNING: TO PREVENT SHOCK HAZARD, DO NOT EXPOSE THIS UNIT TO RAIN OR MOISTURE

NOTE TO CATV INSTALLERS

This reminder is provided to call the CATV System Installer's attention to Article 820-40 of the NEC that provides guidelines for proper grounding and, in particular, specifies that the cable ground shall be connected to the grounding system of the building, as close to the point of cable entry as practical.

Description

The DX is a Modular Digital QAM Upconverter intended for data over cable and digital video-on-demand (VOD) applications. The modular design allows from one to four independent single IF upconverter modules (DX-SXM) to be housed in one 1.75" rack space. The unit uses a common power supply and control module (DX-PSCM) to manage all four of the upconverters. An easy to read back-lit LCD is used to display all of the module information. The unit features an advanced menu system based on a flash upgradable microcontroller. This facilitates programming information to be easily entered with front panel accessible push button navigation switches.

An advanced yet simple computer software package is available to allow local and off-site remote operation and control of the unit including digital level adjustments. Plus, support for redundant standby power is built in as well.

Features

- Modular Design Allows One to Four Single Upconverter Modules in a Single Rack Space
- Fully Agile Output Frequency Range of 54-864 MHz, Std., HRC, IRC and 12.5 KHz Increment Tuning Supported
- Back-Lit LCD Display Panel with Front Panel Accessible Push Button Controls Provides Access to All Vital Unit Information and Makes Set-Up and Troubleshooting a Breeze
- Off-Site Remote Operation and Control Including Digital Adjustment of the QAM RF Output Level with High Performance Computer Software
- 256 QAM & Standby/Redundant Power Capable

DX Instruction Manual

Specifications

IF Input

IF Bandwidth: 6 MHz

IF Frequency:

Digital Center Frequency: 44 MHz

Analog Frequency: 45.75 MHz

Input Impedance: 75

IF Return Loss: 20 dB min.

Input Level: +35 dBmV \pm 1 dB

QAM Output

Output Frequency Range: Agile 54-864 MHz (CATV 2-135)

QAM Bandwidth: 6 MHz

Frequency Step: 12.5 kHz

Output Level: +50 dBmV *

Display Error: \pm 2 dB max.

Level Adjustment Range: 15 dB

Output Modes:

Standard, HRC, IRC & Frequency Tuning in 12.5 kHz Increments

RF Output Impedance: 75

RF Return Loss: 10 dB min.

Spurious: -60 dBc

Broadband Noise:

-75 dBc min. (4 MHz BW @ +50 dBmV Output)

Phase Noise:

@ 1 kHz: -57 dBc min.

@ 10 kHz: -95 dBc min.

@ 20 kHz: -104 dBc min.

Frequency Stability: \pm 5 kHz

Passband Flatness: \pm 3 dB (in a 6 MHz BW)

Controls and Indicators

Computer Control: 2 RJ11 Rear Panel RS232 Connectors

Backlit Liquid Crystal Display (LCD)

5 Push Button Navigation Controls

Mechanical

Dimensions: 1.75 x 19.0 x 18.5 Inches

Mounting:

Standard EIA Unit Height 1.75" x 19" Wide Rack Mount

Unit Weight: 9.5 lbs (4 Channels)

Shipping Weight: 10.5 lbs

Power

Requirement: 100 to 265 VAC

Frequency: 50 to 60 Hz

Power Consumption:

2632-1: 12 Watts

2632-2: 18 Watts

2632-3: 24 Watts

2632-4: 31 Watts

Environmental

Operating Temperature: 0 to 50 °C

Storage Temperature: -20 to 70 °C

Humidity: 0 to 90 % RH

* Average Measurement

DX Instruction Manual

The Unit

Front Panel - DX

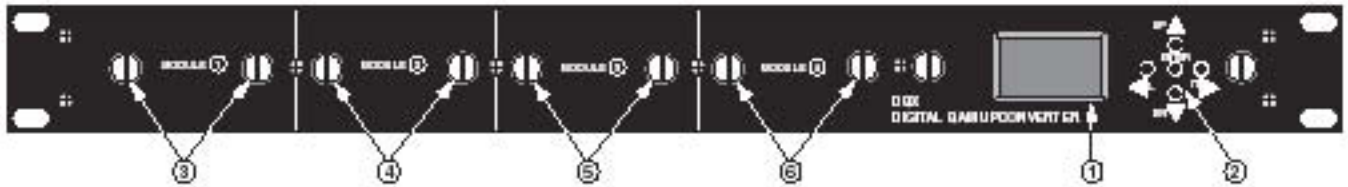

1. **Backlit LCD** - 8 character, 2 line Liquid Crystal Display screen used to interact with user to display unit information.
2. **Push Button Navigation Controls** - Buttons used to navigate between menus and enter unit information.
3. **Retaining Screws** - Module 1
4. **Retaining Screws** - Module 2
5. **Retaining Screws** - Module 3
6. **Retaining Screws** - Module 4

Rear Panel - DX

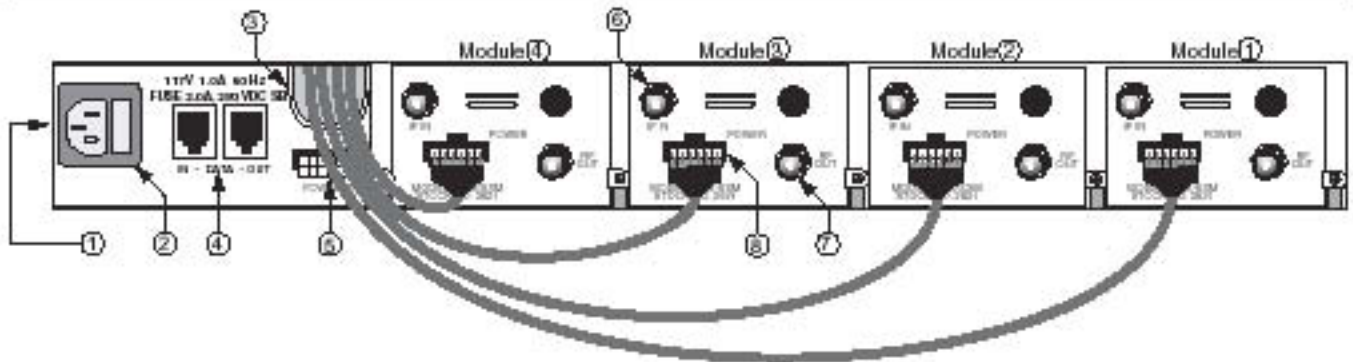

1. **Power Cord Socket** - The unit power cord plug socket.
2. **Fuse Holder** - 2.0 Amp., 250V DC, Slo Blo fuse.
3. **Module Power/Data Cables** - 4 cables with 12-pin male connector used to deliver power and data to each SXM.
4. **RS232 Serial Data Ports** - Used to plug into and daisy chain DQX units for remote monitoring and configuration.
5. **Power IN** - 12-pin female connector used to plug-in the optional Standby Power unit for redundant support.
6. **IF INPUT** - Independent 75 Ω RF connector for feeding appropriate IF input signal.
7. **RF OUTPUT** - Independent 75 Ω RF Output.
8. **Power** - 12-pin female connector used to plug-in cable for respective module to deliver power and data.

Drawings are samples for illustration purposes only and are not to scale

DX Instruction Manual

Installing the Upconverter

Installing the DX in a Rack

Mounting

The upconverter chassis is 1.75 inches tall, 19 inches wide, and 18.5 inches deep.

You can mount the upconverter in a standard EIA, 24 inch (610 mm) deep, enclosed rack. Secure the unit front panel to the rack by inserting four machine screws, with cup washers, through the four mounting holes in the front panel.

IMPORTANT!

DO NOT block the unit's ventilation holes.

When installing one or more DX units in a headend rack, it is recommended to leave a 1 rack unit space (1.75" high) between units to maximize air flow, but it is not required. This space helps to reduce heat build-up in a headend rack and could possibly help to extend the product life span.

We recommend that you support the unit by some means in addition to the front panel screws. You can use rear rail support brackets or rack slides. Rear rail support brackets are available (Order PN 622280100A)

WARNING!



For safe and reliable operation, the upconverter requires a proper ground connection for the third prong of the upconverter power cord plug.

Optional Remote Monitoring & Control Software

Remote Monitoring & Control Software

An optional Remote Monitoring & Control Software package is available. This custom software application is designed to be used for the ability to monitor and configure a DX units in the headend. The software is a program that can be used locally in the direct mode via a null modem cable or remotely in the dial out mode using an external RS-232 serial modem at the headend and the remote site. The software features a user friendly graphical interface and is compatible with widely available Windows® based computers.

DX Instruction Manual

QAM Signal Level Testing

This section describes the proper measurement technique to accurately measure digital QAM signals using a Hewlett Packard Spectrum Analyzer. Measurement of the digital signal level will be that of the total spectral power of the signal. The spectral power of the signal is confined to the 3 dB bandwidth of the signal which is equal to the symbol rate.

Two methods for measuring digital QAM signals are described.

The first and preferred method requires the ability to output a CW (carrier wave) QAM signal. Method 2 uses the actual QAM signal and requires the appropriate correction factors to be applied for the 6 MHz bandwidth of the QAM signal.

QAM Signal Level in CW Mode

The CW QAM signal is used to provide the true equivalent signal level for the QAM carrier. A QAM modulator capable of supplying the output QAM signal in CW mode is required. This simplifies the level measurement process dramatically because the level does not need to be adjusted for the limitation in analyzer bandwidth settings. After setting the appropriate level in CW mode, the modulator is changed back to normal mode.

Any meter that can measure CW Carrier Power Level can be used. The CW Carrier Level is equal to the QAM Power Level that will be presented by a normal QAM signal.

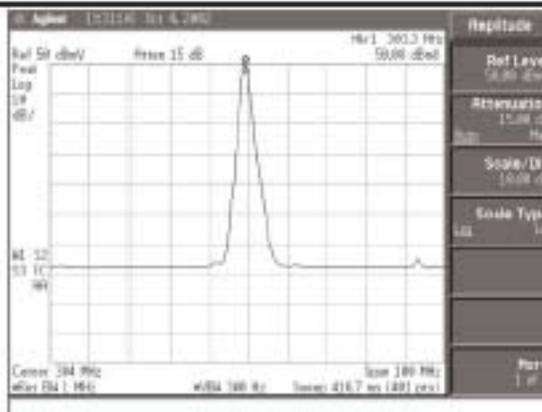

Figure 1 - CW QAM Signal

QAM Signal Level in Normal Mode

Typical spectrum analyzers do not have the ability to measure channel power in a CATV mode, thus there is a need to have a correction factor applied to the measurement to account for the total spectral power.

This correction factor is calculated as:

$$10 \log (\text{Symbol Rate}/\text{Resolution Bandwidth}) + \text{spectrum analyzer correction factor}^{**}$$

Typical settings for spectrum analyzers are as follows:

- Resolution Bandwidth: 300 kHz
- Video Bandwidth: 30 kHz or lower
- Detector Mode: SMPL (SAMPLE)
- Video Averaging (HP 8591C): ON

The spectrum analyzer correction factor is due to three factors:

1. Raleigh distribution,
2. -log amplifier,
3. 3 dB/noise power bandwidths for a total correction of 2.0 dB.

The table below contains the calculated bandwidth correction factor for the 64 QAM symbol rate 5.0569 at a resolution bandwidth of 300 kHz.

Modulation Format	Symbol Rate	Measurement Bandwidth	Bandwidth Correction Factor	Spectrum Analyzer Correction Factor	Total Correction Factor
	(MS/s)	(MHz)	(dB)	(dB)	(dB)
64 QAM	5.0569	5.0569	12.3	2.0	14.3

***Analyzers that have a true RMS detection mode do not require this correction factor.*

DX Instruction Manual

Equipment Needed

- Spectrum Analyzer, (HP 8591 C, E4411B or equivalent)
- Minimum Loss Pad (MLP) or Impedance Transformer
(used to convert satellite signals @ 50 Ω to equipment impedance @ 75 Ω)
- HP8591 C
Ensure that the spectrum analyzer has been on for at least a 1/2 hour and is calibrated.
Refer to the equipment manual for calibration procedure.

Configure the analyzer as follows:

Mode: Spectrum Analyzer

Center Frequency: Center of Channel Under Test

Amplitude Units: dBm

Input Z: 50

Ref Level: Positioned to upper 1/10 of display

Span: Wide enough to capture entire signal under test

RBW: 300 kHz

VBW: 30 kHz or less

Video Averaging: ON

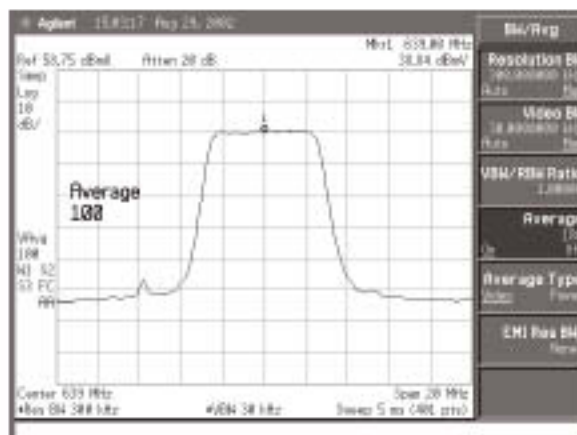

Figure 2 - Average Power QAM Signal

DX Instruction Manual

Mechanical Assembly

The Modules

The DX consists of 3 core modules.

SXM-PSCM - Power Supply & Control Module

SXM - Single Upconverter Module

SXM-4MCH - Four Module Chassis

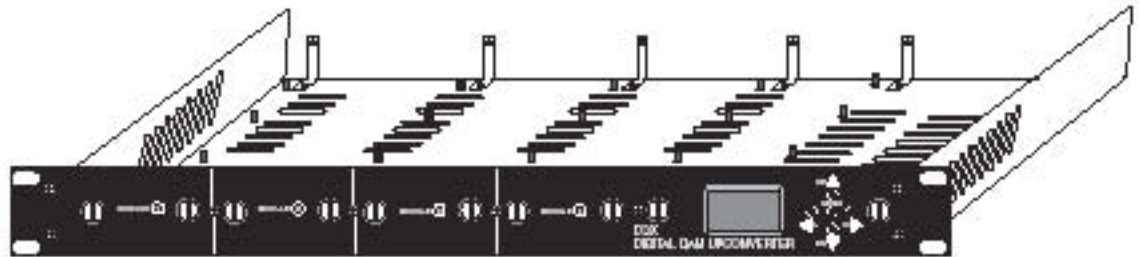

DX Four Module Chassis (DX - 4XCH)

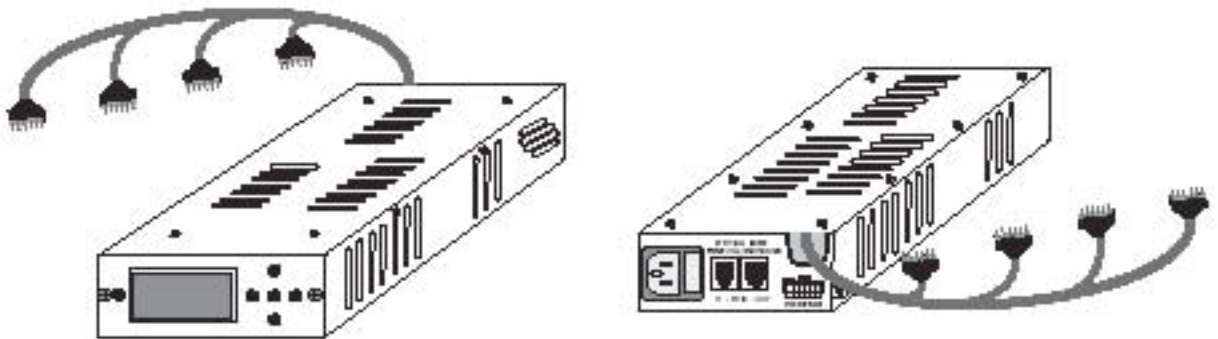

DX - Power Supply & Control Module (DX - PSCM)

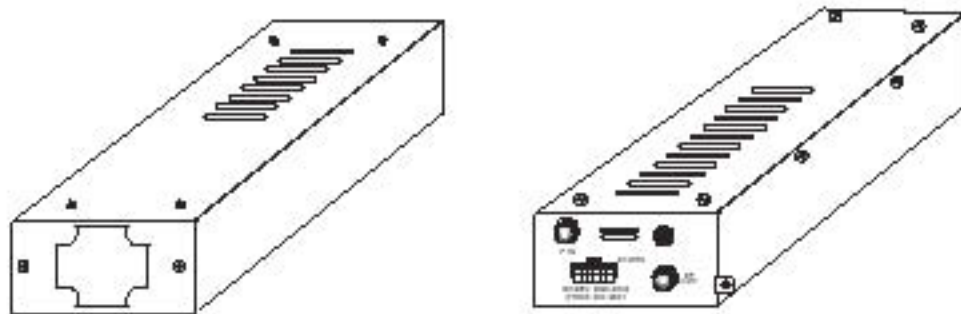

DX - Single Upconverter Module (DX - SXM)

Drawings are samples for illustration purposes only and are not to scale

DX Instruction Manual

Installing the Modules in the Chassis

The following are the recommended instructions for installation of the modules in a chassis:

1. Mount the PSCM module in the chassis by gently sliding it into position.
Be sure to line the switches up with the appropriate holes located in the chassis front panel.
2. Tighten the rear retaining screw to secure the rear of the module in place.
3. Mount all of the appropriate SXM modules in the same manner.
4. Move to the front of the headend and tighten the front panel retaining thumbscrews to fully secure the modules.
5. Wire the appropriate IF input coaxial cables to the SXM's "IF IN" F connector.
6. Wire the output of each module from the "RF OUT" F connector to the appropriate combining/diplexing device.
7. Connect the 12-pin power/data cables labeled module 1 to 4 from the PSCM to the particular upconverter module to the female 12-pin connector labeled "POWER".

NOTE: Make sure the appropriately labeled cable is connected to the corresponding module. This is done to ensure that the correct module is displayed by the LCD and is actually being communicated with correctly. Keep in mind that the modules are numbered 1 to 4 from left to right on the front and will then be housed 1 to 4 from right to left on the rear.

8. Connect the A/C power cord to the Power Supply & Control Module.
9. Connect the 12-pin power/cable from the standby power unit to the "Power In" connector of the PSCM if applicable.

NOTE: You must connect A/C power to the DX-PSCM before you connect power from the standby power unit to prevent the unit from immediately going to standby power mode if applicable.

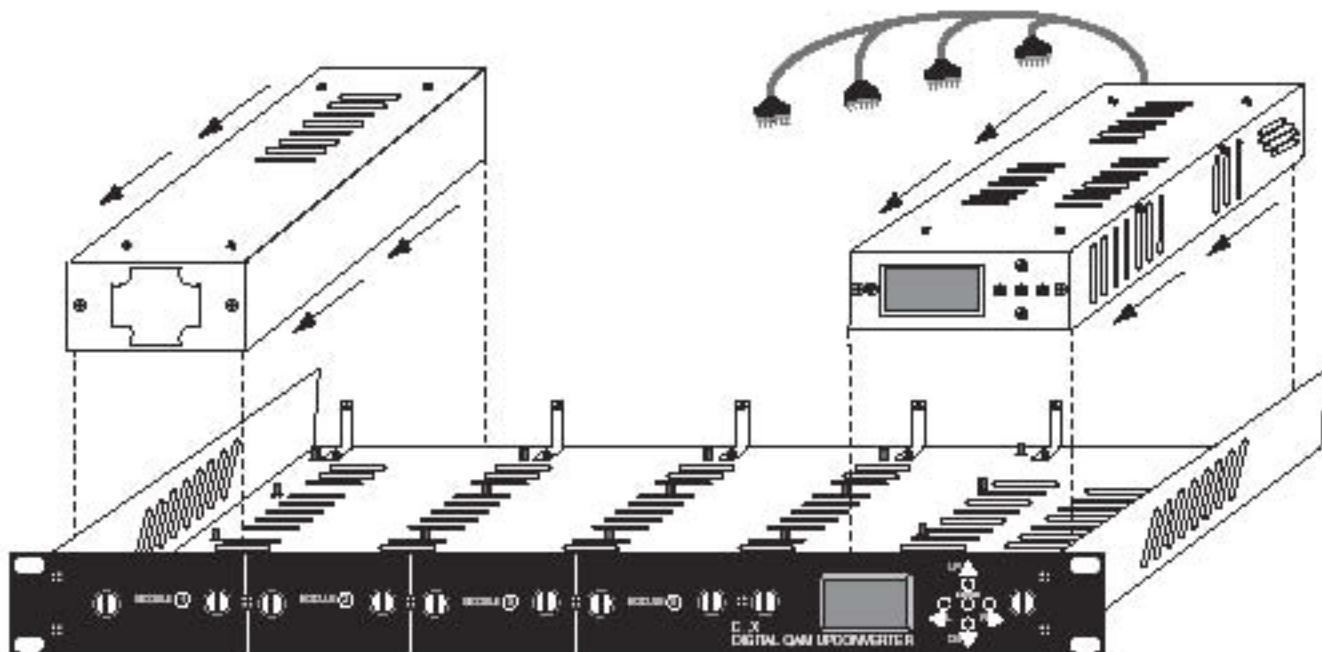

DX - Module Loading Front View

DX Instruction Manual

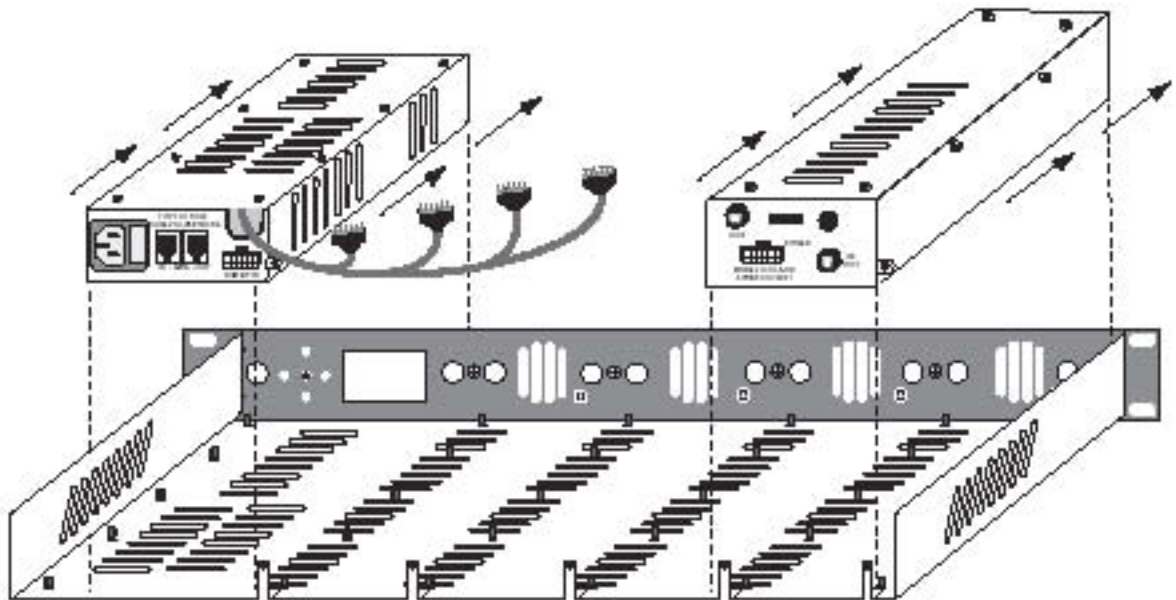

DX - Module Loading Rear View

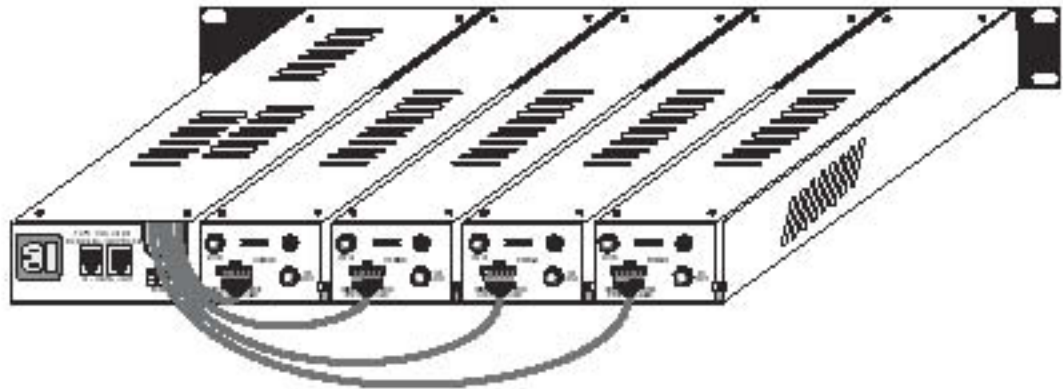

Fully Populated DX Rear View

Drawings are samples for illustration purposes only and are not to scale

DX Instruction Manual

Replacing a SXM

The following are the recommended instructions for replacing a Single Upconverter Module (SXM) while the complete unit is operating:

1. Disconnect the 12-pin power/data cable to the respective module from the PSCM.
2. Disconnect the RF coaxial cables.
3. Physically remove the SXM module from the chassis by loosening the 2 thumbscrews located on the front panel and the one retaining screw on the rear panel.
4. Physically replace the new SXM in the chassis and tighten rear and front retaining screws.
5. Reconnect all RF coaxial cables. (Ensure the correct cable is wired to the input and output accordingly)
6. Reconnect the 12-pin power/data cable to the module from the PSCM.

NOTE: Make sure the appropriately labeled cable is connected to the corresponding module. This is done to ensure that the correct module is displayed by the LCD and is actually being communicated with correctly. Keep in mind that the modules are numbered 1 to 4 from left to right on the front and will then be housed 1 to 4 from right to left on the rear.

When a single SXM is replaced, the PSCM negotiates its status and overwrites its programming information with the programmed information entered on the PSCM. This is intended to make a swap out as simple as possible by minimizing the need to reprogram a SXM in a swap out condition.

Replacing a PSCM

The following are the recommended instructions for replacing a Power Supply & Control Module (PSCM):

1. Remove the standby power cable from the Power In port, if applicable.
2. Remove the A/C power from the PSCM.
3. Remove the 12-pin power/data cables from the respective upconverter modules.
4. Loosen the front panel retaining thumbscrews.
5. Loosen the rear retaining screw.
6. Remove the module from the chassis.
7. Physically replace the new PSCM in the chassis.
Be sure to line the switches up with the appropriate holes located in the chassis front panel.
8. Tighten the rear and front retaining screws to secure the module in place.
9. Reconnect the 12-pin power/data cables to the respective modules.

NOTE: Make sure the appropriately labeled cable is connected to the corresponding module. This is done to ensure that the correct module is displayed by the LCD and is actually being communicated with correctly. Keep in mind that the modules are numbered 1 to 4 from left to right on the front and will then be housed 1 to 4 from right to left on the rear.

10. Connect the A/C power cord to the PSCM.

The unit will now reboot. It will interrogate each of the modules connected. The PSCM will read the programming information from each SXM and overwrite its own information from each respective SXM and display the information accordingly on the LCD. This is designed to make a swap out as simple as possible by minimizing the need to reprogram a PSCM in a swap out condition. After this installation, a user may reprogram any variable if desired.

11. Reconnect Standby Power after boot-up, if applicable.

DX Instruction Manual

DX - Operating Interface Instructions

Introduction

The DX uses an easy to read back-lit LCD (liquid crystal display) panel to provide the operator with as much information about the condition and status of the particular modules installed in the chassis while maintaining as simple a set-up process as possible. The following information describes the LCD methodology and approach.



DX - LCD & Front Panel Navigation Controls

Boot-Up Display Sequence

When the unit is first plugged in for use, the DX control module interrogates the potential upconverter connections and displays the appropriate module condition on the LCD readout as depicted below.

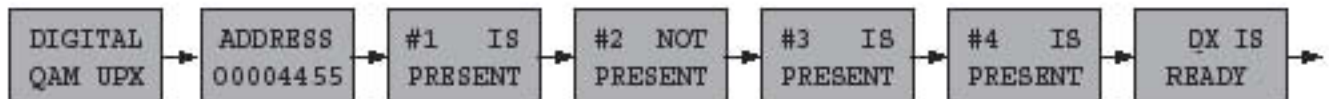

DX - Boot-Up Display Sequence

1. Each control module has a unique module address that is set at the factory which is displayed first.
2. Each single upconverter module status is identified and reported on the LCD. If a module is identified it is listed as present or not present if not connected.

It is during this cycle that the control module is determining the programming status of each module. Basically, the control module determines if the programming information of the module or it's own is to be used. This is designed to make module swaps as simple as possible. (See the previous section on replacing a module for details.)

3. Upon completion of the boot-up sequence the DX is ready for use and will proceed to the loop display sequence.

CAUTION

DO NOT push any switches on the module during this sequence as it will not respond until it displays "DX IS READY".

DX Instruction Manual

Loop Display Sequence

After the unit has displayed the boot-up sequence it proceeds to the loop sequence. In this mode the LCD displays the actual module status as depicted by the diagram below. This is referred to as the loop sequence because this information is constantly displayed in a scrolling fashion on the LCD readout. The loop sequence may be interrupted at any time by pressing the any of the arrow keys.

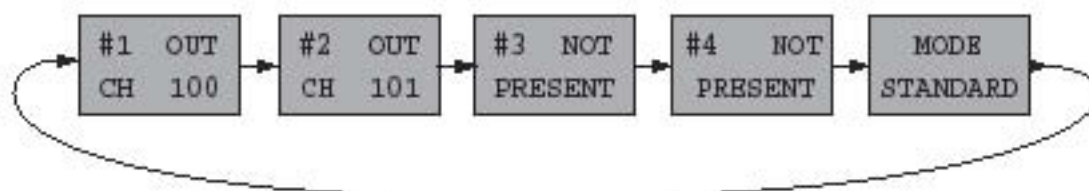

DX - Loop Display Sequence

Main Interactive Sequence

The main interactive sequence is where all the core module programming is performed. This sequence is accessed anytime a user depresses one of the ► (L) or ◀ (R) arrow navigation keys. The following diagram depicts the LCD screens available in the main interactive sequence. The diagram is broken up into 4 rows. They reflect the respective module programming information for each module. Each of the variables in the four rows are user adjustable.

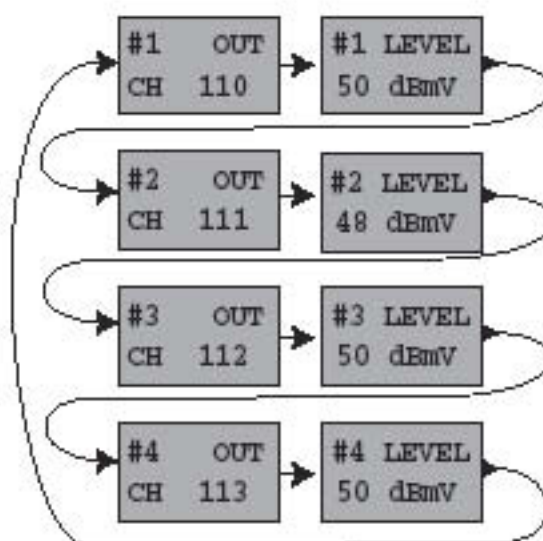

DX - Main Interactive Sequence

Interactive Sequence Logic

Accessing this sequence can be achieved at any time by depressing the ◀ (L) or ► (R) arrow navigation buttons. The user may scroll through the menu screens in either direction at any time to reach a desired variable.

1. Each time the unit is booted up and a user depresses the right arrow navigation button for the first time, the unit will default to # 1 OUT variable. Depressing the left arrow navigation button will present the # 4 Level module information.
2. If no interaction is made to the navigation buttons for approximately 10 seconds, the unit will return to the loop sequence. Depressing the left or right arrow navigation again will return the user to the next, previous location in the sequence.

DX Instruction Manual

Programming a Variable

1. When a user arrives at a screen that a variable needs to be changed, the user depresses and holds the ENTER button until the blinking cursor is displayed (approximately one second).
2. After the blinking cursor is displayed the user simply presses the ▲(UP) or ▼(DN) arrow buttons to increment or decrement to the appropriate desired value.
3. When the user reaches the desired setting the ENTER button is pressed again to save the change. The control module then programs the corresponding upconverter module to the new information.
4. The DX displays an affirmative response after information is entered correctly. The controller will display the "Entry Accepted" response as demonstrated below.

ENTRY
ACCEPTED

Entry Accepted

5. Entries can be made to the controller for all four modules, even if not all modules are installed. The controller will display module "Not Present" response if the module is not installed.

#2 NOT
PRESENT

Module Not Present

6. The DX also displays a response to inform the user if an incorrect entry has been made, such as an entry out of the programmed range. The controller does not accept this information and forces the user to re-enter the correct information.

#1 OUT
OF RANGE

RANGE IS
2 - 135

Out of Range

Output Level

The DX features electronic output level control for each of the single upconverter modules.

The output level is displayed and measured as an average value.
(See the QAM Signal Level Testing section for more detail).

The output level range is +35 dBmV to +50 dBmV.

The output level is specifically calibrated for a +35 dBmV IF input. If the IF input level deviates, the corresponding RF output level will also deviate.

DX Instruction Manual

Advanced Variables

The advanced variable menu is easily accessible by depressing the ▲ (UP) or ▼ (DN) arrow keys on the front of the control module. The user may scroll through the screens depicted by continuing to press the up and down navigation keys.

Several variables cannot be changed and are listed as “display only” variables, such as illustrated below.

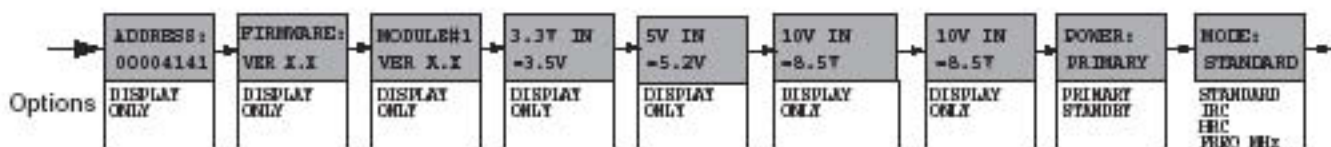

DX - LCD Advanced Interactive Variable Sequence

Programming Notes

The DX has four different programming modes as depicted above. Each mode corresponds to a different frequency plan (see Appendix A for complete frequency listing).

Standard: Allows the entry of the standard CATV channel by number. The corresponding center frequency is automatically programmed by the unit microprocessor.

IRC: Allows the entry of the appropriate IRC channel by number. The corresponding center frequency is automatically programmed by the unit microprocessor.

HRC: Allows the entry of the appropriate HRC channel by number. The corresponding center frequency is automatically programmed by the unit microprocessor.

FREQ MHz: Allows the entry of a specific desired frequency. The unit allows entries in 12.5 KHz increments. Entries are intended to represent the center frequency of the carrier.

Factory Reset

The unit has a “Factory Reset” capability built in that allows a user to erase all the current programming information for the PSCM and restore it to its factory default setting.

To perform this function, press and hold the ▲ (UP) and ▼ (DN) arrow navigation keys simultaneously until the LCD displays “Factory Reset” and then release. This will cause the unit to reset the programmed information to the factory default setting show below.

FACTORY
RESET

Factory Reset

CAUTION

This will reset all programming information for all four modules!

The following are the default factory settings the unit will reset to:

# 1 OUT CH 100 LEVEL: 50 dBmV	# 2 OUT CH 101 LEVEL: 50 dBmV	# 3 OUT CH 102 LEVEL: 50 dBmV	# 4 OUT CH 103 LEVEL: 50 dBmV
----------------------------------	----------------------------------	----------------------------------	----------------------------------

DX Instruction Manual

Appendix A

Frequency Chart 54 Mhz to 864 Mhz

(All Channels Expressed as Center Frequency)

Channel	Standard (QAM)	HRC (QAM)	IRC (QAM)	Channel	Standard (QAM)	HRC (QAM)	IRC (QAM)	Channel	Standard (QAM)	HRC (QAM)	IRC (QAM)
2	57.0000	55.7500	57.0000	50	381.0000	379.7500	381.0000	109	705.0000	703.7500	705.0000
3	63.0000	61.7500	63.0000	51	387.0000	385.7500	387.0000	110	711.0000	709.7500	711.0000
4	69.0000	67.7500	69.0000	52	393.0000	391.7500	393.0000	111	717.0000	715.7500	717.0000
1	N/A	73.7500	75.0000	53	399.0000	397.7500	399.0000	112	723.0000	721.7500	723.0000
5	79.0000	79.7500	81.0000	54	405.0000	403.7500	405.0000	113	729.0000	727.7500	729.0000
95	93.0000	91.7500	93.0000	55	411.0000	409.7500	411.0000	114	735.0000	733.7500	735.0000
96	99.0000	97.7500	99.0000	56	417.0000	415.7500	417.0000	115	741.0000	739.7500	741.0000
97	105.0000	103.7500	105.0000	57	423.0000	421.7500	423.0000	116	747.0000	745.7500	747.0000
98	111.0000	109.7500	111.0000	58	429.0000	427.7500	429.0000	117	753.0000	751.7500	753.0000
99	117.0000	115.7500	117.0000	59	435.0000	433.7500	435.0000	118	759.0000	757.7500	759.0000
6	85.0000	85.7500	87.0000	60	441.0000	439.7500	441.0000	119	765.0000	763.7500	765.0000
14	123.0000	121.7500	123.0000	61	447.0000	445.7500	447.0000	120	771.0000	769.7500	771.0000
15	129.0000	127.7500	129.0000	62	453.0000	451.7500	453.0000	121	777.0000	775.7500	777.0000
16	135.0000	133.7500	135.0000	63	459.0000	457.7500	459.0000	122	783.0000	781.7500	783.0000
17	141.0000	139.7500	141.0000	64	465.0000	463.7500	465.0000	123	789.0000	787.7500	789.0000
18	147.0000	145.7500	147.0000	65	471.0000	469.7500	471.0000	124	795.0000	793.7500	795.0000
19	153.0000	151.7500	153.0000	66	477.0000	475.7500	477.0000	125	801.0000	799.7500	801.0000
20	159.0000	157.7500	159.0000	67	483.0000	481.7500	483.0000	126	807.0000	805.7500	807.0000
21	165.0000	163.7500	165.0000	68	489.0000	487.7500	489.0000	127	813.0000	811.7500	813.0000
22	171.0000	169.7500	171.0000	69	495.0000	493.7500	495.0000	128	819.0000	817.7500	819.0000
7	177.0000	175.7500	177.0000	70	501.0000	499.7500	501.0000	129	825.0000	823.7500	825.0000
8	183.0000	181.7500	183.0000	71	507.0000	505.7500	507.0000	130	831.0000	829.7500	831.0000
9	189.0000	187.7500	189.0000	72	513.0000	511.7500	513.0000	131	837.0000	835.7500	837.0000
10	195.0000	193.7500	195.0000	73	519.0000	517.7500	519.0000	132	843.0000	841.7500	843.0000
11	201.0000	199.7500	201.0000	74	525.0000	523.7500	525.0000	133	849.0000	847.7500	849.0000
12	207.0000	205.7500	207.0000	75	531.0000	529.7500	531.0000	134	855.0000	853.7500	855.0000
13	213.0000	211.7500	213.0000	76	537.0000	535.7500	537.0000	135	861.0000	859.7500	861.0000
23	219.0000	217.7500	219.0000	77	543.0000	541.7500	543.0000				
24	225.0000	223.7500	225.0000	78	549.0000	547.7500	549.0000				
25	231.0000	229.7500	231.0000	79	555.0000	553.7500	555.0000				
26	237.0000	235.7500	237.0000	80	561.0000	559.7500	561.0000				
27	243.0000	241.7500	243.0000	81	567.0000	565.7500	567.0000				
28	249.0000	247.7500	249.0000	82	573.0000	571.7500	573.0000				
29	255.0000	253.7500	255.0000	83	579.0000	577.7500	579.0000				
30	261.0000	259.7500	261.0000	84	585.0000	583.7500	585.0000				
31	267.0000	265.7500	267.0000	85	591.0000	589.7500	591.0000				
32	273.0000	271.7500	273.0000	86	597.0000	595.7500	597.0000				
33	279.0000	277.7500	279.0000	87	603.0000	601.7500	603.0000				
34	285.0000	283.7500	285.0000	88	609.0000	607.7500	609.0000				
35	291.0000	289.7500	291.0000	89	615.0000	613.7500	615.0000				
36	297.0000	295.7500	297.0000	90	621.0000	619.7500	621.0000				
37	303.0000	301.7500	303.0000	91	627.0000	625.7500	627.0000				
38	309.0000	307.7500	309.0000	92	633.0000	631.7500	633.0000				
39	315.0000	313.7500	315.0000	93	639.0000	637.7500	639.0000				
40	321.0000	319.7500	321.0000	94	645.0000	643.7500	645.0000				
41	327.0000	325.7500	327.0000	100	651.0000	649.7500	651.0000				
42	333.0000	331.7500	333.0000	101	657.0000	655.7500	657.0000				
43	339.0000	337.7500	339.0000	102	663.0000	661.7500	663.0000				
44	345.0000	343.7500	345.0000	103	669.0000	667.7500	669.0000				
45	351.0000	349.7500	351.0000	104	675.0000	673.7500	675.0000				
46	357.0000	355.7500	357.0000	105	681.0000	679.7500	681.0000				
47	363.0000	361.7500	363.0000	106	687.0000	685.7500	687.0000				
48	369.0000	367.7500	369.0000	107	693.0000	691.7500	693.0000				
49	375.0000	373.7500	375.0000	108	699.0000	697.7500	699.0000				



Warranty

Our legalese is straightforward. It is simply designed to give you peace of mind and helps you resist the temptation to have your electronics friend try to repair your Technalogix product.

Technalogix Ltd. products have been completely tested and found to meet specifications and be in proper operating condition. They are warranted to be free from defects in materials and workmanship for a period of one year from the date of shipment. If the system becomes damaged in shipment and there are obvious signs of damage to the outside of the packaging, notify your courier immediately before that courier walks out the door.

Technalogix Ltd. will not be liable for damages of whatever nature arising out of or in connection with the equipment or its use thereof. Technalogix does not assume responsibility for injury or damage resulting from the practices of untrained or unqualified personnel in the handling of this equipment.

Technalogix Ltd. warranty does not include:

- misuse, neglect or accident.
- incorrect wiring and /or improper installation.
- unauthorized repairs, modifications or use in violation of instructions issued by Technalogix.
- incidental or consequential damages as a result of any defect.
- reshipment cost or insurance of the unit or replacement units or parts.
- acts of nature or terrorism.

Technalogix agrees, at our option, to remedy warranted defects or furnish a new part in exchange for any part of a unit which, under normal installation, use and service, becomes defective. The user will pay for transportation costs to and from the repair center.



To claim your rights under this warranty:

- Contact Technalogix and describe the problem in as much detail as possible. See troubleshooting section in this manual. If a solution cannot be found at this time, it may be determined that the unit will have to be returned to Technalogix for repair, once a Return Materials Authorization (RMA) number is provided.
- Package equipment carefully for prepaid shipment to Technalogix. Include a written description of the problem experienced, a copy of the original invoice establishing warranty status, and the RMA.

Technalogix reserves the right to make revisions in current production of the equipment and assumes no obligation to incorporate these changes in earlier models.

Shipping Address:

Technalogix Ltd.
ATTN: RMA# _____
#4, 8021 Edgar Industrial Place
Red Deer, Alberta, Canada
T4P 3R3
Ph: 403.347.5400
Made in Canada, returned for repairs

