

FCC Test Report

Report No.: RF180822C04-5

FCC ID: V65E6920

Test Model: E6920

Received Date: Aug. 22, 2018

Test Date: Sep. 25, 2018 ~ Oct. 03, 2018

Issued Date: Oct. 19, 2018

Applicant: Kyocera Corporation c/o Kyocera International, Inc.

Address: 8611 Balboa Avenue, San Diego, CA 92123

Issued By: Bureau Veritas Consumer Products Services (H.K.) Ltd., Taoyuan Branch

Lab Address: No. 47-2, 14th Ling, Chia Pau Vil., Lin Kou Dist., New Taipei City, Taiwan (R.O.C)

Test Location (1): No. 19, Hwa Ya 2nd Rd, Wen Hwa Tsuen, Kwei Shan Hsiang, Taoyuan Hsien 333, Taiwan, R.O.C.

Test Location (2): No.215, Sec. 3, Beixin Rd., Xindian Dist., New Taipei City 231, Taiwan, R.O.C

**FCC Registration /
Designation Number:** 427177 / TW0011



This report is for your exclusive use. Any copying or replication of this report to or for any other person or entity, or use of our name or trademark, is permitted only with our prior written permission. This report sets forth our findings solely with respect to the test samples identified herein. The results set forth in this report are not indicative or representative of the quality or characteristics of the lot from which a test sample was taken or any similar or identical product unless specifically and expressly noted. Our report includes all of the tests requested by you and the results thereof based upon the information that you provided to us. You have 60 days from date of issuance of this report to notify us of any material error or omission caused by our negligence, provided, however, that such notice shall be in writing and shall specifically address the issue you wish to raise. A failure to raise such issue within the prescribed time shall constitute your unqualified acceptance of the completeness of this report, the tests conducted and the correctness of the report contents. Unless specific mention, the uncertainty of measurement has been explicitly taken into account to declare the compliance or non-compliance to the specification. The report must not be used by the client to claim product certification, approval, or endorsement by TAF or any government agencies.

Table of Contents

Release Control Record	4
1 Certificate of Conformity	5
2 Summary of Test Results	6
2.1 Measurement Uncertainty	6
2.2 Modification Record	6
3 General Information	7
3.1 General Description of EUT	7
3.2 Description of Test Modes	9
3.2.1 Test Mode Applicability and Tested Channel Detail	11
3.3 Duty Cycle of Test Signal	13
3.4 Description of Support Units	14
3.4.1 Configuration of System under Test	14
3.5 General Description of Applied Standards	14
4 Test Types and Results	15
4.1 Radiated Emission and Bandedge Measurement	15
4.1.1 Limits of Radiated Emission and Bandedge Measurement	15
4.1.2 Limits of Unwanted Emission Out of the Restricted Bands	16
4.1.3 Test Instruments	17
4.1.4 Test Procedures	18
4.1.5 Deviation from Test Standard	19
4.1.6 Test Set Up	19
4.1.7 EUT Operating Conditions	20
4.1.8 Test Results	21
4.2 Conducted Emission Measurement	61
4.2.1 Limits of Conducted Emission Measurement	61
4.2.2 Test Instruments	61
4.2.3 Test Procedures	62
4.2.4 Deviation from Test Standard	62
4.2.5 Test Setup	62
4.2.6 EUT Operating Conditions	62
4.2.7 Test Results	63
4.3 Transmit Power Measurement	65
4.3.1 Limits of Transmit Power Measurement	65
4.3.2 Test Setup	65
4.3.3 Test Instruments	66
4.3.4 Test Procedure	66
4.3.5 Deviation from Test Standard	66
4.3.6 EUT Operating Conditions	66
4.3.7 Test Result	67
4.4 Occupied Bandwidth Measurement	72
4.4.1 Test Setup	72
4.4.2 Test Instruments	72
4.4.3 Test Procedure	72
4.4.4 Test Results	73
4.5 Peak Power Spectral Density Measurement	76
4.5.1 Limits of Peak Power Spectral Density Measurement	76
4.5.2 Test Setup	76
4.5.3 Test Instruments	76
4.5.4 Test Procedures	76
4.5.5 Deviation from Test Standard	77
4.5.6 EUT Operating Conditions	77
4.5.7 Test Results	78
4.6 Frequency Stability	83

4.6.1	Limit of Frequency Stability Measurement	83
4.6.2	Test Setup	83
4.6.3	Test Instruments	83
4.6.4	Test Procedure	83
4.6.5	Deviation from Test Standard	83
4.6.6	EUT Operating Condition	83
4.6.7	Test Results	84
4.7	6 dB Bandwidth Measurement.....	85
4.7.1	Limits of 6 dB Bandwidth Measurement.....	85
4.7.2	Test Setup.....	85
4.7.3	Test Instruments	85
4.7.4	Test Procedure	85
4.7.5	Deviation from Test Standard	85
4.7.6	EUT Operating Condition	85
4.7.7	Test Results	86
5	Pictures of Test Arrangements.....	88
	Annex A- Radiated Out of Band Emisison (OOBE) Measurement (For U-NII-3 band)	89
	Appendix – Information on the Testing Laboratories	92

Release Control Record

Issue No.	Description	Date Issued
RF180822C04-5	Original Release	Oct. 19, 2018

1 Certificate of Conformity

Product: Smart Phone

Brand: Kyocera

Test Model: E6920

Sample Status: Identical Prototype

Applicant: Kyocera Corporation c/o Kyocera International, Inc.

Test Date: Sep. 25, 2018 ~ Oct. 03, 2018

Standards: 47 CFR FCC Part 15, Subpart E (Section 15.407)
ANSI C63.10:2013

The above equipment has been tested by **Bureau Veritas Consumer Products Services (H.K.) Ltd., Taoyuan Branch**, and found compliance with the requirement of the above standards. The test record, data evaluation & Equipment Under Test (EUT) configurations represented herein are true and accurate accounts of the measurements of the sample's RF characteristics under the conditions specified in this report.

Prepared by : Gina Liu , **Date:** Oct. 19, 2018
Gina Liu / Specialist

Approved by : Dylan Chiou , **Date:** Oct. 19, 2018
Dylan Chiou / Project Engineer

2 Summary of Test Results

47 CFR FCC Part 15, Subpart E (Section 15.407)			
FCC Clause	Test Item	Result	Remarks
15.407(b)(6)	AC Power Conducted Emissions	Pass	Meet the requirement of limit. Minimum passing margin is -15.20 dB at 0.61920 MHz.
15.407(b) (1/2/3/4(i/ii)/6)	Radiated Emissions & Band Edge Measurement	Pass	Meet the requirement of limit. Minimum passing margin is -3.23 dB at 5459.44 MHz.
15.407(a)(1/2/3)	Max Average Transmit Power	Pass	Meet the requirement of limit.
---	Occupied Bandwidth Measurement	-	Reference only
15.407(a)(1/2/3)	Peak Power Spectral Density	Pass	Meet the requirement of limit.
15.407(e)	6 dB Bandwidth	Pass	Meet the requirement of limit. (U-NII-3 Band only)
15.407(g)	Frequency Stability	Pass	Meet the requirement of limit.
15.203	Antenna Requirement	Pass	No antenna connector is used.

*For U-NII-3 band compliance with rule part 15.407(b)(4)(i), the OOBE test plots were recorded in Annex A.

2.1 Measurement Uncertainty

Where relevant, the following measurement uncertainty levels have been estimated for tests performed on the EUT as specified in CISPR 16-4-2:

Measurement	Frequency	Expanded Uncertainty (k=2) (\pm)
Conducted Emissions at mains ports	150 kHz ~ 30 MHz	2.44 dB
Radiated Emissions up to 1 GHz	30 MHz ~ 200 MHz	2.0153 dB
	200 MHz ~ 1000 MHz	2.0224 dB
Radiated Emissions above 1 GHz	1 GHz ~ 18 GHz	1.0121 dB
	18 GHz ~ 40 GHz	1.1508 dB

2.2 Modification Record

There were no modifications required for compliance.

3 General Information

3.1 General Description of EUT

Product	Smart Phone
Brand	Kyocera
Test Model	E6920
Status of EUT	Identical Prototype
Power Supply Rating	3.8 Vdc (Battery) 5 Vdc or 9 Vdc or 12 Vdc (Adapter) 5 Vdc (Host equipment)
Modulation Type	256QAM, 64QAM, 16QAM, QPSK, BPSK
Modulation Technology	OFDM
Transfer Rate	802.11a: 54.0/ 48.0/ 36.0/ 24.0/ 18.0/ 12.0/ 9.0/ 6.0 Mbps 802.11n: up to 150.0 Mbps 802.11ac: up to 433.3 Mbps
Operating Frequency	5180 ~ 5240 MHz, 5260 ~ 5320 MHz, 5500 ~ 5700 MHz, 5745 ~ 5825 MHz
Number of Channel	5180 ~ 5240 MHz: 4 for 802.11a, 802.11n (HT20) 2 for 802.11n (HT40) 1 for 802.11ac (VHT80) 5260 ~ 5320 MHz: 4 for 802.11a, 802.11n (HT20) 2 for 802.11n (HT40) 1 for 802.11ac (VHT80) 5500 ~ 5700 MHz: 11 for 802.11a, 802.11n (HT20) 5 for 802.11n (HT40) 2 for 802.11ac (VHT80) 5745 ~ 5825 MHz: 5 for 802.11a, 802.11n (HT20) 2 for 802.11n (HT40) 1 for 802.11ac (VHT80)
Output Power	68.549 mW for 5180 ~ 5240 MHz 70.469 mW for 5260 ~ 5320 MHz 70.632 mW for 5500 ~ 5700 MHz 70.469 mW for 5745 ~ 5825 MHz
Antenna Type	Fixed Internal antenna with 2.2 dBi gain
Antenna Connector	N/A
Accessory Device	Refer to Note as below
Data Cable Supplied	Refer to Note as below

Note:

1. The EUT provides one transmitter and receiver.

Modulation Mode	Tx Function
802.11a	1TX
802.11n (HT20)	1TX
802.11n (HT40)	1TX
802.11ac (VHT20)	1TX
802.11ac (VHT40)	1TX
802.11ac (VHT80)	1TX

* The modulation and bandwidth are similar for 802.11n mode for HT20 / HT40 and 802.11ac mode for VHT20 / VHT40, therefore investigated worst case to representative mode in test report. (Final test mode refer section 3.2.1)

2. The EUT's accessories list refers to Ext. Pho.
3. The above EUT information is declared by manufacturer and for more detailed features description, please refers to the manufacturer's specifications or user's manual.

3.2 Description of Test Modes

For 5180 ~ 5240 MHz

4 channels are provided for 802.11a, 802.11n (HT20):

Channel	Frequency (MHz)	Channel	Frequency (MHz)
36	5180	44	5220
40	5200	48	5240

2 channels are provided for 802.11n (HT40):

Channel	Frequency (MHz)	Channel	Frequency (MHz)
38	5190	46	5230

1 channel is provided for 802.11ac (VHT80):

Channel	Frequency (MHz)
42	5210

For 5260 ~ 5320 MHz

4 channels are provided for 802.11a, 802.11n (HT20):

Channel	Frequency (MHz)	Channel	Frequency (MHz)
52	5260	60	5300
56	5280	64	5320

2 channels are provided for 802.11n (HT40):

Channel	Frequency (MHz)	Channel	Frequency (MHz)
54	5270	62	5310

1 channel is provided for 802.11ac (VHT80):

Channel	Frequency (MHz)
58	5290

For 5500 ~ 5700 MHz

11 channels are provided for 802.11a, 802.11n (HT20):

Channel	Frequency (MHz)	Channel	Frequency (MHz)
100	5500	124	5620
104	5520	128	5640
108	5540	132	5660
112	5560	136	5680
116	5580	140	5700
120	5600		

5 channels are provided for 802.11n (HT40):

Channel	Frequency (MHz)	Channel	Frequency (MHz)
102	5510	126	5630
110	5550	134	5670
118	5590		

2 channels are provided for 802.11ac (VHT80):

Channel	Frequency (MHz)	Channel	Frequency (MHz)
106	5530	122	5610

For 5745 ~ 5825 MHz:

5 channels are provided for 802.11a, 802.11n (HT20):

Channel	Frequency (MHz)	Channel	Frequency (MHz)
149	5745	161	5805
153	5765	165	5825
157	5785		

2 channels are provided for 802.11n (HT40):

Channel	Frequency (MHz)	Channel	Frequency (MHz)
151	5755	159	5795

1 channel is provided for 802.11ac (VHT80):

Channel	Frequency (MHz)
155	5775

3.2.1 Test Mode Applicability and Tested Channel Detail

EUT Configure Mode	Applicable To				Description
	RE \geq 1G	RE $<$ 1G	PLC	APCM	
-	√	√	√	√	-

Where **RE \geq 1G**: Radiated Emission above 1 GHz **RE $<$ 1G**: Radiated Emission below 1 GHz
PLC: Power Line Conducted Emission **APCM**: Antenna Port Conducted Measurement

Note:

1. The EUT had been pre-tested on the positioned of each 3 axis. The worst case was found when positioned on **Y-plane**.
2. "-" means no effect.

Radiated Emission Test (Above 1 GHz):

- Pre-Scan has been conducted to determine the worst-case mode from all possible combinations between available modulations, data rates and antenna ports (if EUT with antenna diversity architecture).
- Following channel(s) was (were) selected for the final test as listed below.

EUT Configure Mode	Frequency Band (MHz)	Mode	Available Channel	Tested Channel	Modulation Technology	Modulation Type	Data Rate (Mbps)
-	5180-5240	802.11a	36 to 48	36, 40, 48	OFDM	BPSK	6.0
-		802.11n (HT20)	36 to 48	36, 40, 48	OFDM	BPSK	6.5
-		802.11n (HT40)	38 to 46	38, 46	OFDM	BPSK	13.5
-		802.11ac (VHT80)	42	42	OFDM	BPSK	29.3
-	5260-5320	802.11a	52 to 64	52, 60, 64	OFDM	BPSK	6.0
-		802.11n (HT20)	52 to 64	52, 60, 64	OFDM	BPSK	6.5
-		802.11n (HT40)	54 to 62	54, 62	OFDM	BPSK	13.5
-		802.11ac (VHT80)	58	58	OFDM	BPSK	29.3
-	5500-5700	802.11a	100 to 140	100, 116, 140	OFDM	BPSK	6.0
-		802.11n (HT20)	100 to 140	100, 116, 140	OFDM	BPSK	6.5
-		802.11n (HT40)	102 to 134	102, 110, 134	OFDM	BPSK	13.5
-		802.11ac (VHT80)	106 to 122	106, 122	OFDM	BPSK	29.3
-	5745-5825	802.11a	149 to 165	149, 157, 165	OFDM	BPSK	6.0
-		802.11n (HT20)	149 to 165	149, 157, 165	OFDM	BPSK	6.5
-		802.11n (HT40)	151 to 159	151, 159	OFDM	BPSK	13.5
-		802.11ac (VHT80)	155	155	OFDM	BPSK	29.3

Radiated Emission Test (Below 1 GHz):

- Pre-Scan has been conducted to determine the worst-case mode from all possible combinations between available modulations, data rates and antenna ports (if EUT with antenna diversity architecture).
- Following channel(s) was (were) selected for the final test as listed below.

EUT Configure Mode	Frequency Band (MHz)	Mode	Available Channel	Tested Channel	Modulation Technology	Modulation Type	Data Rate (Mbps)
-	5500-5700	802.11ac (VHT80)	106 to 122	106	OFDM	BPSK	29.3

Power Line Conducted Emission Test:

- Pre-Scan has been conducted to determine the worst-case mode from all possible combinations between available modulations, data rates and antenna ports (if EUT with antenna diversity architecture).
- Following channel(s) was (were) selected for the final test as listed below.

EUT Configure Mode	Frequency Band (MHz)	Mode	Available Channel	Tested Channel	Modulation Technology	Modulation Type	Data Rate (Mbps)
-	5500-5700	802.11ac (VHT80)	106 to 122	106	OFDM	BPSK	29.3

Antenna Port Conducted Measurement:

- This item includes all test value of each mode, but only includes spectrum plot of worst value of each mode.
- Pre-Scan has been conducted to determine the worst-case mode from all possible combinations between available modulations, data rates and antenna ports (if EUT with antenna diversity architecture).
- Following channel(s) was (were) selected for the final test as listed below.

EUT Configure Mode	Frequency Band (MHz)	Mode	Available Channel	Tested Channel	Modulation Technology	Modulation Type	Data Rate (Mbps)
-	5180-5240	802.11a	36 to 48	36, 40, 48	OFDM	BPSK	6.0
-		802.11n (HT20)	36 to 48	36, 40, 48	OFDM	BPSK	6.5
-		802.11n (HT40)	38 to 46	38, 46	OFDM	BPSK	13.5
-		802.11ac (VHT80)	42	42	OFDM	BPSK	29.3
-	5260-5320	802.11a	52 to 64	52, 60, 64	OFDM	BPSK	6.0
-		802.11n (HT20)	52 to 64	52, 60, 64	OFDM	BPSK	6.5
-		802.11n (HT40)	54 to 62	54, 62	OFDM	BPSK	13.5
-		802.11ac (VHT80)	58	58	OFDM	BPSK	29.3
-	5500-5700	802.11a	100 to 140	100, 116, 140	OFDM	BPSK	6.0
-		802.11n (HT20)	100 to 140	100, 116, 140	OFDM	BPSK	6.5
-		802.11n (HT40)	102 to 134	102, 110, 134	OFDM	BPSK	13.5
-		802.11ac (VHT80)	106 to 122	106, 122	OFDM	BPSK	29.3
-	5745-5825	802.11a	149 to 165	149, 157, 165	OFDM	BPSK	6.0
-		802.11n (HT20)	149 to 165	149, 157, 165	OFDM	BPSK	6.5
-		802.11n (HT40)	151 to 159	151, 159	OFDM	BPSK	13.5
-		802.11ac (VHT80)	155	155	OFDM	BPSK	29.3

Test Condition:

Applicable To	Environmental Conditions	Input Power	Tested by
RE \geq 1G	25 deg. C, 65 % RH	120 Vac, 60 Hz	Charles Hsiao, Karl Lee
RE $<$ 1G	25 deg. C, 65 % RH	120 Vac, 60 Hz	Harry Hsueh
PLC	25 deg. C, 65 % RH	120 Vac, 60 Hz	Jisyong Wang
APCM	25 deg. C, 65 % RH	3.8 Vdc	Wayne Lin

3.3 Duty Cycle of Test Signal

MODULATION TYPE: BPSK

Duty cycle of test signal is < 98 %, duty factor is required.

802.11a: Duty cycle = $1.341/1.434 = 0.935$, Duty factor = $10 * \log(1/0.935) = 0.29$

802.11n (HT20): Duty cycle = $1.257/1.458 = 0.862$, Duty factor = $10 * \log(1/0.862) = 0.64$

802.11n (HT40): Duty cycle = $0.624/0.754 = 0.828$, Duty factor = $10 * \log(1/0.828) = 0.82$

802.11ac (VHT80): Duty cycle = $0.313/0.407 = 0.769$, Duty factor = $10 * \log(1/0.769) = 1.14$

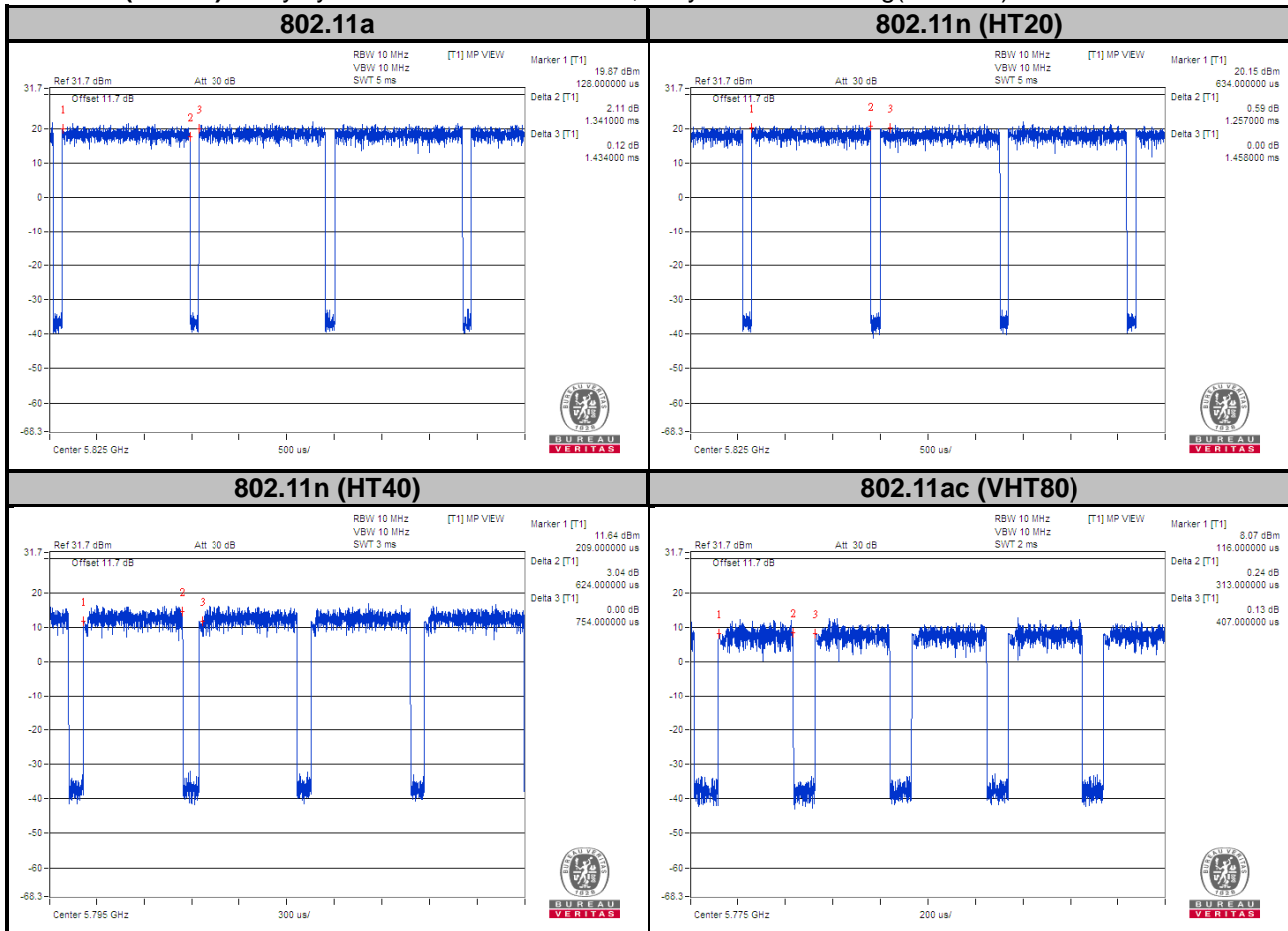

3.4 Description of Support Units

The EUT has been tested as an independent unit together with other necessary accessories or support units. The following support units or accessories were used to form a representative test configuration during the tests.

No.	Product	Brand	Model No.	Serial No.	FCC ID
1.	Earphone	Funkey	FK130102	N/A	N/A

No.	Signal Cable Description Of The Above Support Units
1.	N/A

Note:

1. All power cords of the above support units are non-shielded (1.8m).

3.4.1 Configuration of System under Test

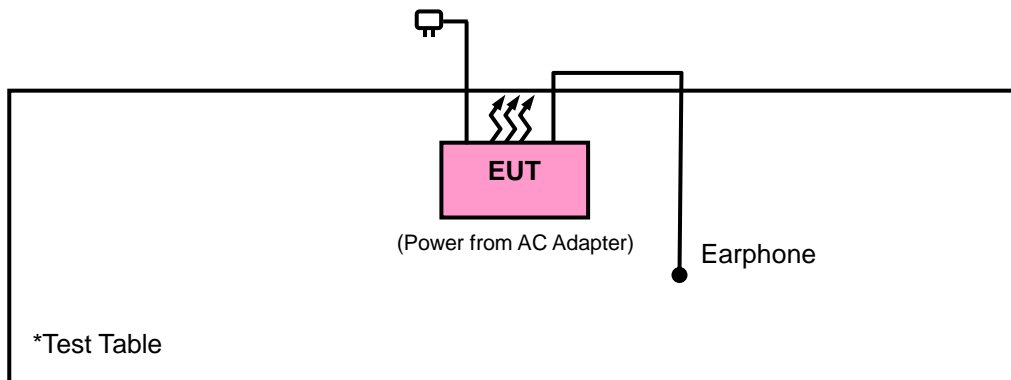

3.5 General Description of Applied Standards

The EUT is a RF Product. According to the specifications of the manufacturer, it must comply with the requirements of the following standards:

FCC Part 15, Subpart E (15.407)

KDB 789033 D02 General UNII Test Procedures New Rules v02r01

ANSI C63.10-2013

All test items have been performed and recorded as per the above standards.

4 Test Types and Results

4.1 Radiated Emission and Bandedge Measurement

4.1.1 Limits of Radiated Emission and Bandedge Measurement

Radiated emissions which fall in the restricted bands must comply with the radiated emission limits specified as below table.

Frequencies (MHz)	Field Strength (microvolts/meter)	Measurement Distance (meters)
0.009 ~ 0.490	2400/F (kHz)	300
0.490 ~ 1.705	24000/F (kHz)	30
1.705 ~ 30.0	30	30
30 ~ 88	100	3
88 ~ 216	150	3
216 ~ 960	200	3
Above 960	500	3

Note:

1. The lower limit shall apply at the transition frequencies.
2. Emission level (dBuV/m) = 20 log Emission level (uV/m).
3. For frequencies above 1000 MHz, the field strength limits are based on average detector, however, the peak field strength of any emission shall not exceed the maximum permitted average limits, specified above by more than 20 dB under any condition of modulation.

4.1.2 Limits of Unwanted Emission Out of the Restricted Bands

Applicable To		Limit	
789033 D02 General UNII Test Procedures New Rules v02r01		Field Strength at 3 m	
		PK: 74 (dBµV/m)	AV: 54 (dBµV/m)
Frequency Band	Applicable To	EIRP Limit	Equivalent Field Strength at 3 m
5150~5250 MHz	15.407(b)(1)	PK: -27 (dBm/MHz)	PK: 68.2 (dBµV/m)
5250~5350 MHz	15.407(b)(2)		
5470~5725 MHz	15.407(b)(3)		
5725~5850 MHz	15.407(b)(4)(i)	PK:-27 (dBm/MHz) ^{*1} PK:10 (dBm/MHz) ^{*2} PK:15.6 (dBm/MHz) ^{*3} PK:27 (dBm/MHz) ^{*4}	PK: 68.2 (dBµV/m) ^{*1} PK:105.2 (dBµV/m) ^{*2} PK: 110.8 (dBµV/m) ^{*3} PK:122.2 (dBµV/m) ^{*4}
	15.407(b)(4)(ii)	Emission limits in section 15.247(d)	
^{*1} beyond 75 MHz or more above of the band edge. ^{*2} below the band edge increasing linearly to 10 dBm/MHz at 25 MHz above. ^{*3} below the band edge increasing linearly to a level of 15.6 dBm/MHz at 5 MHz above. ^{*4} from 5 MHz above or below the band edge increasing linearly to a level of 27 dBm/MHz at the band edge.			

Note:

The following formula is used to convert the equipment isotropic radiated power (eirp) to field strength:

$$E = \frac{1000000\sqrt{30P}}{3} \mu\text{V/m, where P is the eirp (Watts).}$$

4.1.3 Test Instruments

Description & Manufacturer	Model No.	Serial No.	Date of Calibration	Due Date of Calibration
Test Receiver Agilent Technologies	N9038A	MY52260177	Aug. 20, 2018	Aug. 19, 2019
Spectrum Analyzer ROHDE & SCHWARZ	FSU43	101261	Jan. 11, 2018	Jan. 10, 2019
HORN Antenna ETS-Lindgren	3117	00143293	Dec. 13, 2017	Dec. 12, 2018
BILOG Antenna SCHWARZBECK	VULB 9168	9168-616	Dec. 14, 2017	Dec. 13, 2018
HORN Antenna SCHWARZBECK	BBHA 9170	9170-480	Dec. 01, 2017	Nov. 30, 2018
Fixed Attenuator Woken	00801A1GGAM02Y	NA	May 17, 2018	May 16, 2019
Loop Antenna	EM-6879	269	Sep. 07, 2018	Sep. 06, 2019
Preamplifier Agilent	310N	187226	Jun. 19, 2018	Jun. 18, 2019
Preamplifier Agilent	83017A	MY39501357	Jun. 19, 2018	Jun. 18, 2019
Preamplifier EMCI	EMC 184045	980116	Oct. 20, 2017	Oct. 19, 2018
Power Meter Anritsu	ML2495A	1012010	Sep. 05, 2018	Sep. 04, 2019
Power Sensor Anritsu	MA2411B	1315050	Sep. 04, 2018	Sep. 03, 2019
RF signal cable ETS-LINDGREN	5D-FB	Cable-CH1-01(RFC-S MS-100-SMS-120+RF C-SMS-100-SMS-400)	Jun. 19, 2018	Jun. 18, 2019
RF signal cable ETS-LINDGREN	8D-FB	Cable-CH1-02(RFC-S MS-100-SMS-24)	Jun. 19, 2018	Jun. 18, 2019
Boresight Antenna Fixture	FBA-01	FBA-SIP01	NA	NA
Software BV ADT	E3 8.130425b	NA	NA	NA
Antenna Tower MF	NA	NA	NA	NA
Turn Table MF	NA	NA	NA	NA
Antenna Tower & Turn Table Controller MF	MF-7802	NA	NA	NA
Temperature & Humidity Chamber	GTH-120-40-CP-AR	MAA1306-019	Jul. 17, 2018	Jul. 16, 2019
DC Power Supply Topward	33010D	807748	Oct. 25, 2016	Oct. 24, 2018

- Note: 1. The calibration interval of the above test instruments is 12 / 24 months and the calibrations are traceable to NML/ROC and NIST/USA.
2. The test was performed in HsinTien Chamber 1.
3. The horn antenna and preamplifier (model: 83017A) are used only for the measurement of emission frequency above 1 GHz if tested.
4. The IC Site Registration No. is IC7450I-1.

4.1.4 Test Procedures

For Radiated Emission below 30 MHz

- a. The EUT was placed on the top of a rotating table 0.8 meters above the ground at a 3 meter chamber room. The table was rotated 360 degrees to determine the position of the highest radiation.
- b. The EUT was set 3 meters away from the interference-receiving antenna, which was mounted on the top of a variable-height antenna tower.
- c. Both Parallel, perpendicular, and ground-parallel orientations of the antenna are set to make the measurement.
- d. For each suspected emission, the EUT was arranged to its worst case and the rotatable table was turned from 0 degrees to 360 degrees to find the maximum reading.
- e. The test-receiver system was set to Quasi-Peak Detect Function and Specified Bandwidth with Maximum Hold Mode.

Note:

1. The resolution bandwidth and video bandwidth of test receiver/spectrum analyzer is 9 kHz at frequency below 30 MHz.

For Radiated Emission above 30 MHz

- a. The EUT was placed on the top of a rotating table 0.8 meters (for 30 MHz ~ 1 GHz) / 1.5 meters (for above 1 GHz) above the ground at 3 meter chamber room for test. The table was rotated 360 degrees to determine the position of the highest radiation.
- b. The EUT was set 3 meters away from the interference-receiving antenna, which was mounted on the top of a variable-height antenna tower.
- c. The height of antenna is varied from one meter to four meters above the ground to determine the maximum value of the field strength. Both horizontal and vertical polarizations of the antenna are set to make the measurement.
- d. For each suspected emission, the EUT was arranged to its worst case and then the antenna was tuned to heights from 1 meter to 4 meters and the rotatable table was turned from 0 degrees to 360 degrees to find the maximum reading.
- e. The test-receiver system was set to quasi-peak detect function and specified bandwidth with maximum hold mode when the test frequency is below 1 GHz.
- f. The test-receiver system was set to peak and average detected function and specified bandwidth with maximum hold mode when the test frequency is above 1 GHz. If the peak reading value also meets average limit, measurement with the average detector is unnecessary.

Note:

1. The resolution bandwidth and video bandwidth of test receiver/spectrum analyzer is 120 kHz for Quasi-peak detection (QP) at frequency below 1 GHz.
2. The resolution bandwidth of test receiver/spectrum analyzer is 1 MHz and the video bandwidth is 3 MHz for Peak detection (PK) at frequency above 1 GHz.
3. The resolution bandwidth of test receiver/spectrum analyzer is 1 MHz and the video bandwidth is $\geq 1/T$ (Duty cycle < 98 %) or 10 Hz (Duty cycle ≥ 98 %) for Average detection (AV) at frequency above 1 GHz.
(11a: RBW = 1 MHz, VBW = 1 kHz ; 11n (HT20): RBW = 1 MHz, VBW = 1 kHz ;
11n (HT40): RBW = 1 MHz, VBW = 3 kHz ; 11ac (VHT80): RBW = 1 MHz, VBW = 10 kHz)
4. All modes of operation were investigated and the worst-case emissions are reported.

4.1.5 Deviation from Test Standard

No deviation.

4.1.6 Test Setup

<Radiated Emission below 30 MHz>

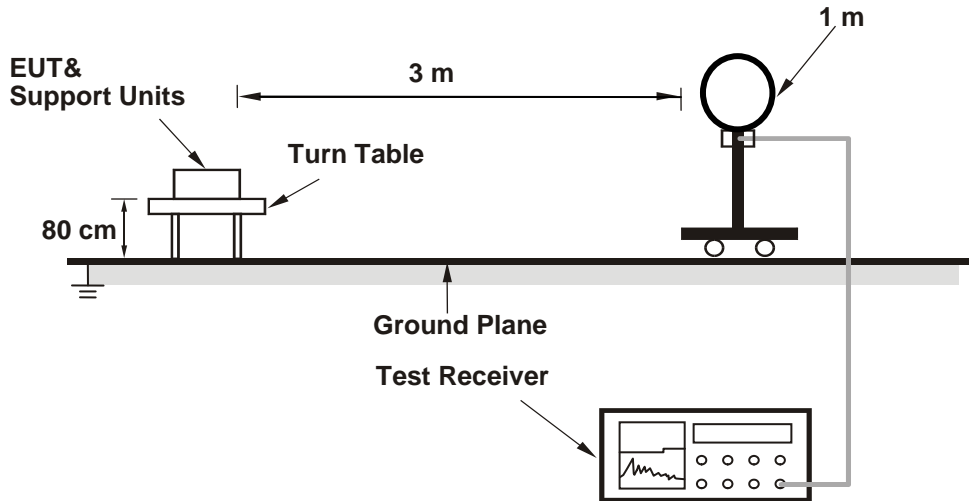

<Radiated Emission 30 MHz to 1 GHz>

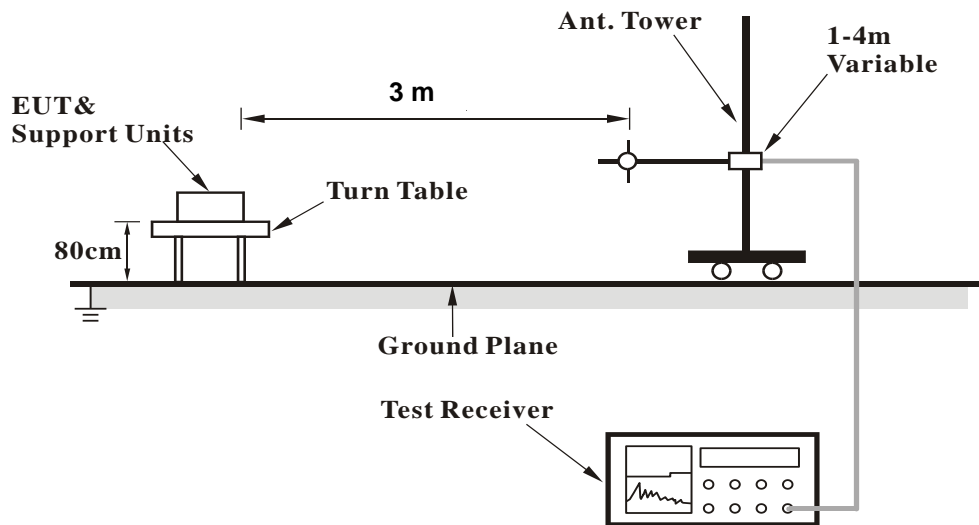

<Radiated Emission above 1 GHz>

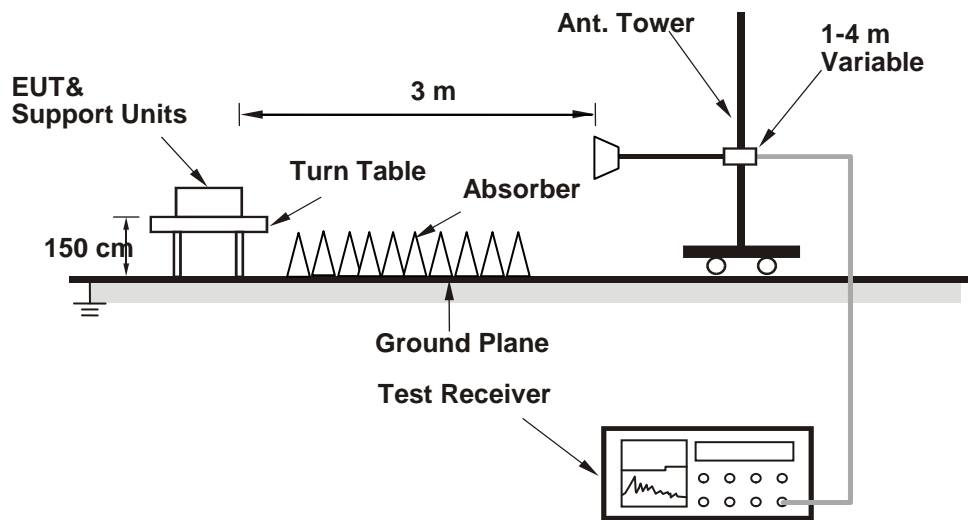

For the actual test configuration, please refer to the attached file (Test Setup Photo).

4.1.7 EUT Operating Conditions

- Placed the EUT on a testing table.
- Use the software to control the EUT under transmission condition continuously at specific channel frequency.

4.1.8 Test Results
Above 1 GHz Data :
802.11a

EUT Test Condition		Measurement Detail	
Channel	Channel 36	Frequency Range	1 GHz ~ 40 GHz
Input Power	120 Vac, 60 Hz	Detector Function	Peak (PK) Average (AV)
Environmental Conditions	25 deg. C, 65 % RH	Tested By	Charles Hsiao

Antenna Polarity & Test Distance: Horizontal at 3 m										
Frequency (MHz)	Emission Level (dBuV/m)	Read Level (dBuV)	Limit (dBuV/m)	Margin (dB)	Antenna Factor (dB/m)	Cable Loss (dB)	Preamp Factor (dB)	Antenna Height (cm)	Table Angle (Degree)	Remark
5147.3	43.84	35.59	54	-10.16	34.12	8.13	34	100	170	Average
5147.3	53.94	45.69	74	-20.06	34.12	8.13	34	100	170	Peak
5180	97.77	89.46			34.15	8.16	34	100	170	Average
5180	104.85	96.54			34.15	8.16	34	100	170	Peak
*10360	55.3	41	68.2	-12.9	37.12	12.3	35.12	158	8	Peak

Antenna Polarity & Test Distance: Vertical at 3 m										
Frequency (MHz)	Emission Level (dBuV/m)	Read Level (dBuV)	Limit (dBuV/m)	Margin (dB)	Antenna Factor (dB/m)	Cable Loss (dB)	Preamp Factor (dB)	Antenna Height (cm)	Table Angle (Degree)	Remark
5144	42.77	34.52	54	-11.23	34.12	8.13	34	100	213	Average
5144	53.1	44.85	74	-20.9	34.12	8.13	34	100	213	Peak
5180	93.66	85.35			34.15	8.16	34	100	213	Average
5180	100.87	92.56			34.15	8.16	34	100	213	Peak
*10360	56.8	42.5	68.2	-11.4	37.12	12.3	35.12	124	112	Peak

Remarks:

- Emission Level = Read Level + Antenna Factor + Cable Loss - Preamp Factor
 Margin value = Emission level – Limit value
- 5180 MHz: Fundamental Frequency
- *: Out of Restricted Band
- The emission levels of other frequencies were very low against the limit

EUT Test Condition		Measurement Detail	
Channel	Channel 40	Frequency Range	1 GHz ~ 40 GHz
Input Power	120 Vac, 60 Hz	Detector Function	Peak (PK) Average (AV)
Environmental Conditions	25 deg. C, 65 % RH	Tested By	Charles Hsiao

Antenna Polarity & Test Distance: Horizontal at 3 m										
Frequency (MHz)	Emission Level (dBuV/m)	Read Level (dBuV)	Limit (dBuV/m)	Margin (dB)	Antenna Factor (dB/m)	Cable Loss (dB)	Preamp Factor (dB)	Antenna Height (cm)	Table Angle (Degree)	Remark
5148.65	44.35	36.1	54	-9.65	34.12	8.13	34	100	170	Average
5148.65	54.27	46.02	74	-19.73	34.12	8.13	34	100	170	Peak
5200	98.56	90.21			34.16	8.19	34	100	170	Average
5200	105.94	97.59			34.16	8.19	34	100	170	Peak
5357.37	42.43	33.8	54	-11.57	34.28	8.38	34.03	100	170	Average
5357.37	53.31	44.68	74	-20.69	34.28	8.38	34.03	100	170	Peak
*10400	54.87	40.53	68.2	-13.33	37.14	12.36	35.16	134	290	Peak
Antenna Polarity & Test Distance: Vertical at 3 m										
Frequency (MHz)	Emission Level (dBuV/m)	Read Level (dBuV)	Limit (dBuV/m)	Margin (dB)	Antenna Factor (dB/m)	Cable Loss (dB)	Preamp Factor (dB)	Antenna Height (cm)	Table Angle (Degree)	Remark
5139.65	42.87	34.61	54	-11.13	34.12	8.13	33.99	100	213	Average
5139.65	54.52	46.26	74	-19.48	34.12	8.13	33.99	100	213	Peak
5200	94.47	86.12			34.16	8.19	34	100	213	Average
5200	101.54	93.19			34.16	8.19	34	100	213	Peak
5445.81	42.38	33.55	54	-11.62	34.36	8.51	34.04	100	213	Average
5445.81	53.05	44.22	74	-20.95	34.36	8.51	34.04	100	213	Peak
*10400	56.09	41.75	68.2	-12.11	37.14	12.36	35.16	114	155	Peak

Remarks:

- Emission Level = Read Level + Antenna Factor + Cable Loss - Preamp Factor
Margin value = Emission level – Limit value
- 5200 MHz: Fundamental Frequency
- *: Out of Restricted Band
- The emission levels of other frequencies were very low against the limit

EUT Test Condition		Measurement Detail	
Channel	Channel 48	Frequency Range	1 GHz ~ 40 GHz
Input Power	120 Vac, 60 Hz	Detector Function	Peak (PK) Average (AV)
Environmental Conditions	25 deg. C, 65 % RH	Tested By	Charles Hsiao

Antenna Polarity & Test Distance: Horizontal at 3 m										
Frequency (MHz)	Emission Level (dBuV/m)	Read Level (dBuV)	Limit (dBuV/m)	Margin (dB)	Antenna Factor (dB/m)	Cable Loss (dB)	Preamp Factor (dB)	Antenna Height (cm)	Table Angle (Degree)	Remark
5240	99.57	91.13			34.19	8.26	34.01	100	170	Average
5240	106.74	98.3			34.19	8.26	34.01	100	170	Peak
5352.31	42.63	34	54	-11.37	34.28	8.38	34.03	100	170	Average
5352.31	53.56	44.93	74	-20.44	34.28	8.38	34.03	100	170	Peak
*10480	55.42	40.91	68.2	-12.78	37.19	12.53	35.21	124	1	Peak

Antenna Polarity & Test Distance: Vertical at 3 m										
Frequency (MHz)	Emission Level (dBuV/m)	Read Level (dBuV)	Limit (dBuV/m)	Margin (dB)	Antenna Factor (dB/m)	Cable Loss (dB)	Preamp Factor (dB)	Antenna Height (cm)	Table Angle (Degree)	Remark
5240	95.48	87.04			34.19	8.26	34.01	100	213	Average
5240	102.69	94.25			34.19	8.26	34.01	100	213	Peak
5389.49	42.46	33.78	54	-11.54	34.31	8.41	34.04	100	213	Average
5389.49	53.19	44.51	74	-20.81	34.31	8.41	34.04	100	213	Peak
*10480	56.12	41.61	68.2	-12.08	37.19	12.53	35.21	119	35	Peak

Remarks:

- Emission Level = Read Level + Antenna Factor + Cable Loss - Preamp Factor
Margin value = Emission level – Limit value
- 5240 MHz: Fundamental Frequency
- *: Out of Restricted Band
- The emission levels of other frequencies were very low against the limit

EUT Test Condition		Measurement Detail	
Channel	Channel 52	Frequency Range	1 GHz ~ 40 GHz
Input Power	120 Vac, 60 Hz	Detector Function	Peak (PK) Average (AV)
Environmental Conditions	25 deg. C, 65 % RH	Tested By	Charles Hsiao

Antenna Polarity & Test Distance: Horizontal at 3 m										
Frequency (MHz)	Emission Level (dBuV/m)	Read Level (dBuV)	Limit (dBuV/m)	Margin (dB)	Antenna Factor (dB/m)	Cable Loss (dB)	Preamp Factor (dB)	Antenna Height (cm)	Table Angle (Degree)	Remark
5149.55	42.73	34.48	54	-11.27	34.12	8.13	34	123	182	Average
5149.55	53.11	44.86	74	-20.89	34.12	8.13	34	123	182	Peak
5260	100.47	92.01			34.21	8.26	34.01	123	182	Average
5260	107.64	99.18			34.21	8.26	34.01	123	182	Peak
*10520	55.74	41.15	68.2	-12.46	37.21	12.61	35.23	154	288	Peak

Antenna Polarity & Test Distance: Vertical at 3 m										
Frequency (MHz)	Emission Level (dBuV/m)	Read Level (dBuV)	Limit (dBuV/m)	Margin (dB)	Antenna Factor (dB/m)	Cable Loss (dB)	Preamp Factor (dB)	Antenna Height (cm)	Table Angle (Degree)	Remark
5105.3	42.28	34.12	54	-11.72	34.08	8.07	33.99	100	194	Average
5105.3	52.46	44.3	74	-21.54	34.08	8.07	33.99	100	194	Peak
5260	95.61	87.15			34.21	8.26	34.01	100	194	Average
5260	102.55	94.09			34.21	8.26	34.01	100	194	Peak
*10520	54.9	40.31	68.2	-13.3	37.21	12.61	35.23	124	213	Peak

Remarks:

- Emission Level = Read Level + Antenna Factor + Cable Loss - Preamp Factor
Margin value = Emission level – Limit value
- 5260 MHz: Fundamental Frequency
- *: Out of Restricted Band
- The emission levels of other frequencies were very low against the limit

EUT Test Condition		Measurement Detail	
Channel	Channel 60	Frequency Range	1 GHz ~ 40 GHz
Input Power	120 Vac, 60 Hz	Detector Function	Peak (PK) Average (AV)
Environmental Conditions	25 deg. C, 65 % RH	Tested By	Charles Hsiao

Antenna Polarity & Test Distance: Horizontal at 3 m										
Frequency (MHz)	Emission Level (dBuV/m)	Read Level (dBuV)	Limit (dBuV/m)	Margin (dB)	Antenna Factor (dB/m)	Cable Loss (dB)	Preamp Factor (dB)	Antenna Height (cm)	Table Angle (Degree)	Remark
5111.3	42.32	34.12	54	-11.68	34.09	8.1	33.99	123	182	Average
5111.3	53.07	44.87	74	-20.93	34.09	8.1	33.99	123	182	Peak
5300	100.56	92.02			34.24	8.32	34.02	123	182	Average
5300	107.48	98.94			34.24	8.32	34.02	123	182	Peak
5355.72	43.5	34.87	54	-10.5	34.28	8.38	34.03	123	182	Average
5355.72	53.74	45.11	74	-20.26	34.28	8.38	34.03	123	182	Peak
10600	46.91	32.23	54	-7.09	37.28	12.67	35.27	124	7	Average
10600	56.85	42.17	74	-17.15	37.28	12.67	35.27	124	7	Peak

Antenna Polarity & Test Distance: Vertical at 3 m										
Frequency (MHz)	Emission Level (dBuV/m)	Read Level (dBuV)	Limit (dBuV/m)	Margin (dB)	Antenna Factor (dB/m)	Cable Loss (dB)	Preamp Factor (dB)	Antenna Height (cm)	Table Angle (Degree)	Remark
5105.6	42.27	0.11	54	-11.73	34.09	8.07	0	100	194	Average
5105.6	52.41	44.24	74	-21.59	34.09	8.07	33.99	100	194	Peak
5300	95.63	87.09			34.24	8.32	34.02	100	194	Average
5300	102.89	94.35			34.24	8.32	34.02	100	194	Peak
5350	43.32	34.69	54	-10.68	34.28	8.38	34.03	100	194	Average
5350	53.27	44.64	74	-20.73	34.28	8.38	34.03	100	194	Peak
10600	46.78	32.1	54	-7.22	37.28	12.67	35.27	134	115	Average
10600	56.06	41.38	74	-17.94	37.28	12.67	35.27	134	115	Peak

Remarks:

- Emission Level = Read Level + Antenna Factor + Cable Loss - Preamp Factor
Margin value = Emission level – Limit value
- 5300 MHz: Fundamental Frequency
- The emission levels of other frequencies were very low against the limit

EUT Test Condition		Measurement Detail	
Channel	Channel 64	Frequency Range	1 GHz ~ 40 GHz
Input Power	120 Vac, 60 Hz	Detector Function	Peak (PK) Average (AV)
Environmental Conditions	25 deg. C, 65 % RH	Tested By	Charles Hsiao

Antenna Polarity & Test Distance: Horizontal at 3 m										
Frequency (MHz)	Emission Level (dBuV/m)	Read Level (dBuV)	Limit (dBuV/m)	Margin (dB)	Antenna Factor (dB/m)	Cable Loss (dB)	Preamp Factor (dB)	Antenna Height (cm)	Table Angle (Degree)	Remark
5320	99.74	91.16			34.25	8.35	34.02	123	182	Average
5320	106.63	98.05			34.25	8.35	34.02	123	182	Peak
5356.49	43.94	35.31	54	-10.06	34.28	8.38	34.03	123	182	Average
5356.49	53.87	45.24	74	-20.13	34.28	8.38	34.03	123	182	Peak
10640	46.5	31.77	54	-7.5	37.31	12.71	35.29	147	4	Average
10640	55.16	40.43	74	-18.84	37.31	12.71	35.29	147	4	Peak

Antenna Polarity & Test Distance: Vertical at 3 m										
Frequency (MHz)	Emission Level (dBuV/m)	Read Level (dBuV)	Limit (dBuV/m)	Margin (dB)	Antenna Factor (dB/m)	Cable Loss (dB)	Preamp Factor (dB)	Antenna Height (cm)	Table Angle (Degree)	Remark
5320	94.65	86.07			34.25	8.35	34.02	100	194	Average
5320	101.14	92.56			34.25	8.35	34.02	100	194	Peak
5363.42	43.04	34.4	54	-10.96	34.29	8.38	34.03	100	194	Average
5363.42	53.67	45.03	74	-20.33	34.29	8.38	34.03	100	194	Peak
10640	46.85	32.12	54	-7.15	37.31	12.71	35.29	134	333	Average
10640	55.65	40.92	74	-18.35	37.31	12.71	35.29	134	333	Peak

Remarks:

- Emission Level = Read Level + Antenna Factor + Cable Loss - Preamp Factor
Margin value = Emission level – Limit value
- 5320 MHz: Fundamental Frequency
- The emission levels of other frequencies were very low against the limit

EUT Test Condition		Measurement Detail	
Channel	Channel 100	Frequency Range	1 GHz ~ 40 GHz
Input Power	120 Vac, 60 Hz	Detector Function	Peak (PK) Average (AV)
Environmental Conditions	25 deg. C, 65 % RH	Tested By	Karl Lee

Antenna Polarity & Test Distance: Horizontal at 3 m										
Frequency (MHz)	Emission Level (dBuV/m)	Read Level (dBuV)	Limit (dBuV/m)	Margin (dB)	Antenna Factor (dB/m)	Cable Loss (dB)	Preamp Factor (dB)	Antenna Height (cm)	Table Angle (Degree)	Remark
5459.76	43.29	34.47	54	-10.71	34.36	8.51	34.05	102	150	Average
5459.76	53.52	44.7	74	-20.48	34.36	8.51	34.05	102	150	Peak
*5470.96	52.81	43.95	68.2	-15.39	34.37	8.54	34.05	102	150	Peak
5500	95.21	86.29			34.4	8.57	34.05	102	150	Average
5500	102.28	93.36			34.4	8.57	34.05	102	150	Peak
11000	47.62	32.54	54	-6.38	37.6	12.96	35.48	127	180	Average
11000	57.33	42.25	74	-16.67	37.6	12.96	35.48	127	180	Peak
Antenna Polarity & Test Distance: Vertical at 3 m										
Frequency (MHz)	Emission Level (dBuV/m)	Read Level (dBuV)	Limit (dBuV/m)	Margin (dB)	Antenna Factor (dB/m)	Cable Loss (dB)	Preamp Factor (dB)	Antenna Height (cm)	Table Angle (Degree)	Remark
5446.8	42.86	34.03	54	-11.14	34.36	8.51	34.04	251	269	Average
5446.8	53.53	44.7	74	-20.47	34.36	8.51	34.04	251	269	Peak
*5470.48	52.1	43.27	68.2	-16.1	34.37	8.51	34.05	251	269	Peak
5500	90.15	81.23			34.4	8.57	34.05	251	269	Average
5500	97.19	88.27			34.4	8.57	34.05	251	269	Peak
11000	47.1	32.02	54	-6.9	37.6	12.96	35.48	163	227	Average
11000	56.6	41.52	74	-17.4	37.6	12.96	35.48	163	227	Peak

Remarks:

- Emission Level = Read Level + Antenna Factor + Cable Loss - Preamp Factor
Margin value = Emission level – Limit value
- 5500 MHz: Fundamental Frequency
- *: Out of Restricted Band
- The emission levels of other frequencies were very low against the limit

EUT Test Condition		Measurement Detail	
Channel	Channel 116	Frequency Range	1 GHz ~ 40 GHz
Input Power	120 Vac, 60 Hz	Detector Function	Peak (PK) Average (AV)
Environmental Conditions	25 deg. C, 65 % RH	Tested By	Karl Lee

Antenna Polarity & Test Distance: Horizontal at 3 m										
Frequency (MHz)	Emission Level (dBuV/m)	Read Level (dBuV)	Limit (dBuV/m)	Margin (dB)	Antenna Factor (dB/m)	Cable Loss (dB)	Preamp Factor (dB)	Antenna Height (cm)	Table Angle (Degree)	Remark
5436.56	42.95	34.16	54	-11.05	34.35	8.48	34.04	103	150	Average
5436.56	53.22	44.43	74	-20.78	34.35	8.48	34.04	103	150	Peak
*5468.08	52.13	43.3	68.2	-16.07	34.37	8.51	34.05	103	150	Peak
5580	99.46	90.47			34.47	8.6	34.08	103	150	Average
5580	107.33	98.34			34.47	8.6	34.08	103	150	Peak
*5724.6	52.22	43.06	68.2	-15.98	34.62	8.65	34.11	103	150	Peak
11160	48.23	33.15	54	-5.77	37.7	12.83	35.45	169	223	Average
11160	57.75	42.67	74	-16.25	37.7	12.83	35.45	169	223	Peak

Antenna Polarity & Test Distance: Vertical at 3 m										
Frequency (MHz)	Emission Level (dBuV/m)	Read Level (dBuV)	Limit (dBuV/m)	Margin (dB)	Antenna Factor (dB/m)	Cable Loss (dB)	Preamp Factor (dB)	Antenna Height (cm)	Table Angle (Degree)	Remark
5459.92	42.63	33.81	54	-11.37	34.36	8.51	34.05	251	269	Average
5459.92	53.63	44.81	74	-20.37	34.36	8.51	34.05	251	269	Peak
*5470.64	51.99	43.16	68.2	-16.21	34.37	8.51	34.05	251	269	Peak
5580	93.95	84.96			34.47	8.6	34.08	251	269	Average
5580	102.08	93.09			34.47	8.6	34.08	251	269	Peak
*5725.72	52.24	43.08	68.2	-15.96	34.62	8.65	34.11	251	269	Peak
11160	48.13	33.05	54	-5.87	37.7	12.83	35.45	106	76	Average
11160	57.87	42.79	74	-16.13	37.7	12.83	35.45	106	76	Peak

Remarks:

- Emission Level = Read Level + Antenna Factor + Cable Loss - Preamp Factor
Margin value = Emission level – Limit value
- 5580 MHz: Fundamental Frequency
- *: Out of Restricted Band
- The emission levels of other frequencies were very low against the limit

EUT Test Condition		Measurement Detail	
Channel	Channel 140	Frequency Range	1 GHz ~ 40 GHz
Input Power	120 Vac, 60 Hz	Detector Function	Peak (PK) Average (AV)
Environmental Conditions	25 deg. C, 65 % RH	Tested By	Karl Lee

Antenna Polarity & Test Distance: Horizontal at 3 m										
Frequency (MHz)	Emission Level (dBuV/m)	Read Level (dBuV)	Limit (dBuV/m)	Margin (dB)	Antenna Factor (dB/m)	Cable Loss (dB)	Preamp Factor (dB)	Antenna Height (cm)	Table Angle (Degree)	Remark
5700	94.6	85.47			34.59	8.64	34.1	106	183	Average
5700	102.32	93.19			34.59	8.64	34.1	106	183	Peak
*5724.68	53.76	44.6	68.2	-14.44	34.62	8.65	34.11	106	183	Peak
11400	47.36	32.26	54	-6.64	37.84	12.67	35.41	142	170	Average
11400	57.06	41.96	74	-16.94	37.84	12.67	35.41	142	170	Peak

Antenna Polarity & Test Distance: Vertical at 3 m										
Frequency (MHz)	Emission Level (dBuV/m)	Read Level (dBuV)	Limit (dBuV/m)	Margin (dB)	Antenna Factor (dB/m)	Cable Loss (dB)	Preamp Factor (dB)	Antenna Height (cm)	Table Angle (Degree)	Remark
5700	90.33	81.2			34.59	8.64	34.1	236	267	Average
5700	97.8	88.67			34.59	8.64	34.1	236	267	Peak
*5726.04	52.84	43.68	68.2	-15.36	34.62	8.65	34.11	236	267	Peak
11400	47.43	32.33	54	-6.57	37.84	12.67	35.41	185	273	Average
11400	57.1	42	74	-16.9	37.84	12.67	35.41	185	273	Peak

Remarks:

- Emission Level = Read Level + Antenna Factor + Cable Loss - Preamp Factor
Margin value = Emission level – Limit value
- 5700 MHz: Fundamental Frequency
- *: Out of Restricted Band
- The emission levels of other frequencies were very low against the limit

EUT Test Condition		Measurement Detail	
Channel	Channel 149	Frequency Range	1 GHz ~ 40 GHz
Input Power	120 Vac, 60 Hz	Detector Function	Peak (PK) Average (AV)
Environmental Conditions	25 deg. C, 65 % RH	Tested By	Karl Lee

<Spurious Emission>

Antenna Polarity & Test Distance: Horizontal at 3 m										
Frequency (MHz)	Emission Level (dBuV/m)	Read Level (dBuV)	Limit (dBuV/m)	Margin (dB)	Antenna Factor (dB/m)	Cable Loss (dB)	Preamp Factor (dB)	Antenna Height (cm)	Table Angle (Degree)	Remark
5745	92.87	83.68			34.64	8.66	34.11	110	184	Average
5745	100.09	90.9			34.64	8.66	34.11	110	184	Peak
11490	46.52	31.4	54	-7.48	37.89	12.62	35.39	158	8	Average
11490	56.48	41.36	74	-17.52	37.89	12.62	35.39	158	8	Peak
Antenna Polarity & Test Distance: Vertical at 3 m										
Frequency (MHz)	Emission Level (dBuV/m)	Read Level (dBuV)	Limit (dBuV/m)	Margin (dB)	Antenna Factor (dB/m)	Cable Loss (dB)	Preamp Factor (dB)	Antenna Height (cm)	Table Angle (Degree)	Remark
5745	87.33	78.14			34.64	8.66	34.11	220	276	Average
5745	95.47	86.28			34.64	8.66	34.11	220	276	Peak
11490	46.61	31.49	54	-7.39	37.89	12.62	35.39	124	118	Average
11490	56.33	41.21	74	-17.67	37.89	12.62	35.39	124	118	Peak

<Out of Band Emission (OOBE)>

Antenna Polarity & Test Distance: Horizontal at 3 m										
Frequency (MHz)	Emission Level (dBuV/m)	Read Level (dBuV)	Limit (dBuV/m)	Margin (dB)	Antenna Factor (dB/m)	Cable Loss (dB)	Preamp Factor (dB)	Antenna Height (cm)	Table Angle (Degree)	Remark
*5582.425	53.71	44.7	68.2	-14.49	34.49	8.6	34.08	110	184	Peak
5653.3	51.61	42.51	70.64	-19.03	34.56	8.63	34.09	110	184	Peak
5922.1	50.82	41.42	70.35	-19.53	34.83	8.73	34.16	110	184	Peak
*5971.975	54.36	44.91	68.2	-13.84	34.87	8.75	34.17	110	184	Peak
Antenna Polarity & Test Distance: Vertical at 3 m										
Frequency (MHz)	Emission Level (dBuV/m)	Read Level (dBuV)	Limit (dBuV/m)	Margin (dB)	Antenna Factor (dB/m)	Cable Loss (dB)	Preamp Factor (dB)	Antenna Height (cm)	Table Angle (Degree)	Remark
*5645.425	53.76	44.69	68.2	-14.44	34.54	8.62	34.09	220	276	Peak
5652.25	51.56	42.47	69.86	-18.3	34.56	8.62	34.09	220	276	Peak
5922.625	50.56	41.16	69.96	-19.4	34.83	8.73	34.16	220	276	Peak
*5937.85	55.03	45.63	68.2	-13.17	34.83	8.73	34.16	220	276	Peak

Remarks:

- Emission Level = Read Level + Antenna Factor + Cable Loss - Preamp Factor
Margin value = Emission level – Limit value
- 5745 MHz: Fundamental Frequency
- *: Out of Restricted Band
- The emission levels of other frequencies were very low against the limit

EUT Test Condition		Measurement Detail	
Channel	Channel 157	Frequency Range	1 GHz ~ 40 GHz
Input Power	120 Vac, 60 Hz	Detector Function	Peak (PK) Average (AV)
Environmental Conditions	25 deg. C, 65 % RH	Tested By	Karl Lee

<Spurious Emission>

Antenna Polarity & Test Distance: Horizontal at 3 m										
Frequency (MHz)	Emission Level (dBuV/m)	Read Level (dBuV)	Limit (dBuV/m)	Margin (dB)	Antenna Factor (dB/m)	Cable Loss (dB)	Preamp Factor (dB)	Antenna Height (cm)	Table Angle (Degree)	Remark
5785	100.41	91.18			34.68	8.68	34.13	138	184	Average
5785	108.23	99			34.68	8.68	34.13	138	184	Peak
11570	47.33	32.02	54	-6.67	38	12.68	35.37	154	7	Average
11570	56.56	41.25	74	-17.44	38	12.68	35.37	154	7	Peak
Antenna Polarity & Test Distance: Vertical at 3 m										
Frequency (MHz)	Emission Level (dBuV/m)	Read Level (dBuV)	Limit (dBuV/m)	Margin (dB)	Antenna Factor (dB/m)	Cable Loss (dB)	Preamp Factor (dB)	Antenna Height (cm)	Table Angle (Degree)	Remark
5785	93.28	84.05			34.68	8.68	34.13	220	276	Average
5785	102.89	93.66			34.68	8.68	34.13	220	276	Peak
11570	47.3	31.99	54	-6.7	38	12.68	35.37	134	322	Average
11570	57.04	41.73	74	-16.96	38	12.68	35.37	134	322	Peak

<Out of Band Emission (OOBE)>

Antenna Polarity & Test Distance: Horizontal at 3 m										
Frequency (MHz)	Emission Level (dBuV/m)	Read Level (dBuV)	Limit (dBuV/m)	Margin (dB)	Antenna Factor (dB/m)	Cable Loss (dB)	Preamp Factor (dB)	Antenna Height (cm)	Table Angle (Degree)	Remark
*5644.9	52.96	43.89	68.2	-15.24	34.54	8.62	34.09	138	184	Peak
5651.725	52.88	43.79	69.48	-16.6	34.56	8.62	34.09	138	184	Peak
5923.675	52.28	42.88	69.18	-16.9	34.83	8.73	34.16	138	184	Peak
*5970.4	53.34	43.89	68.2	-14.86	34.87	8.75	34.17	138	184	Peak
Antenna Polarity & Test Distance: Vertical at 3 m										
Frequency (MHz)	Emission Level (dBuV/m)	Read Level (dBuV)	Limit (dBuV/m)	Margin (dB)	Antenna Factor (dB/m)	Cable Loss (dB)	Preamp Factor (dB)	Antenna Height (cm)	Table Angle (Degree)	Remark
*5559.85	53.67	44.7	68.2	-14.53	34.45	8.59	34.07	220	276	Peak
5652.775	53.28	44.18	70.25	-16.97	34.56	8.63	34.09	220	276	Peak
5923.15	50.82	41.42	69.57	-18.75	34.83	8.73	34.16	220	276	Peak
*6024.475	54.07	44.55	68.2	-14.13	34.93	8.77	34.18	220	276	Peak

Remarks:

- Emission Level = Read Level + Antenna Factor + Cable Loss - Preamp Factor
Margin value = Emission level – Limit value
- 5785 MHz: Fundamental Frequency
- *: Out of Restricted Band
- The emission levels of other frequencies were very low against the limit

EUT Test Condition		Measurement Detail	
Channel	Channel 165	Frequency Range	1 GHz ~ 40 GHz
Input Power	120 Vac, 60 Hz	Detector Function	Peak (PK) Average (AV)
Environmental Conditions	25 deg. C, 65 % RH	Tested By	Karl Lee

<Spurious Emission>

Antenna Polarity & Test Distance: Horizontal at 3 m										
Frequency (MHz)	Emission Level (dBuV/m)	Read Level (dBuV)	Limit (dBuV/m)	Margin (dB)	Antenna Factor (dB/m)	Cable Loss (dB)	Preamp Factor (dB)	Antenna Height (cm)	Table Angle (Degree)	Remark
5825	97.58	88.29			34.73	8.69	34.13	140	184	Average
5825	104.33	95.04			34.73	8.69	34.13	140	184	Peak
11650	47.57	32.04	54	-6.43	38.09	12.8	35.36	189	244	Average
11650	56.09	40.56	74	-17.91	38.09	12.8	35.36	189	244	Peak
Antenna Polarity & Test Distance: Vertical at 3 m										
Frequency (MHz)	Emission Level (dBuV/m)	Read Level (dBuV)	Limit (dBuV/m)	Margin (dB)	Antenna Factor (dB/m)	Cable Loss (dB)	Preamp Factor (dB)	Antenna Height (cm)	Table Angle (Degree)	Remark
5825	91.83	82.54			34.73	8.69	34.13	220	276	Average
5825	99.35	90.06			34.73	8.69	34.13	220	276	Peak
11650	47.65	32.12	54	-6.35	38.09	12.8	35.36	131	322	Average
11650	55.66	40.13	74	-18.34	38.09	12.8	35.36	131	322	Peak

<Out of Band Emission (OOBE)>

Antenna Polarity & Test Distance: Horizontal at 3 m										
Frequency (MHz)	Emission Level (dBuV/m)	Read Level (dBuV)	Limit (dBuV/m)	Margin (dB)	Antenna Factor (dB/m)	Cable Loss (dB)	Preamp Factor (dB)	Antenna Height (cm)	Table Angle (Degree)	Remark
*5634.925	53.93	44.86	68.2	-14.27	34.54	8.62	34.09	140	184	Peak
5651.725	51.26	42.17	69.48	-18.22	34.56	8.62	34.09	140	184	Peak
5923.675	52.99	43.59	69.18	-16.19	34.83	8.73	34.16	140	184	Peak
*5985.625	53.36	43.9	68.2	-14.84	34.88	8.75	34.17	140	184	Peak
Antenna Polarity & Test Distance: Vertical at 3 m										
Frequency (MHz)	Emission Level (dBuV/m)	Read Level (dBuV)	Limit (dBuV/m)	Margin (dB)	Antenna Factor (dB/m)	Cable Loss (dB)	Preamp Factor (dB)	Antenna Height (cm)	Table Angle (Degree)	Remark
*5549.35	53.37	44.4	68.2	-14.83	34.45	8.59	34.07	220	276	Peak
5652.775	52.61	43.51	70.25	-17.64	34.56	8.63	34.09	220	276	Peak
5923.675	51.13	41.73	69.18	-18.05	34.83	8.73	34.16	220	276	Peak
*5931.55	53.56	44.16	68.2	-14.64	34.83	8.73	34.16	220	276	Peak

Remarks:

- Emission Level = Read Level + Antenna Factor + Cable Loss - Preamp Factor
Margin value = Emission level – Limit value
- 5825 MHz: Fundamental Frequency
- *: Out of Restricted Band
- The emission levels of other frequencies were very low against the limit

802.11n (HT20)

EUT Test Condition		Measurement Detail	
Channel	Channel 36	Frequency Range	1 GHz ~ 40 GHz
Input Power	120 Vac, 60 Hz	Detector Function	Peak (PK) Average (AV)
Environmental Conditions	25 deg. C, 65 % RH	Tested By	Charles Hsiao

Antenna Polarity & Test Distance: Horizontal at 3 m

Frequency (MHz)	Emission Level (dBuV/m)	Read Level (dBuV)	Limit (dBuV/m)	Margin (dB)	Antenna Factor (dB/m)	Cable Loss (dB)	Preamp Factor (dB)	Antenna Height (cm)	Table Angle (Degree)	Remark
5150	44.63	36.38	54	-9.37	34.12	8.13	34	100	170	Average
5150	53.86	45.61	74	-20.14	34.12	8.13	34	100	170	Peak
5180	98.76	90.45			34.15	8.16	34	100	170	Average
5180	105.25	96.94			34.15	8.16	34	100	170	Peak
*10360	55.24	40.94	68.2	-12.96	37.12	12.3	35.12	112	25	Peak

Antenna Polarity & Test Distance: Vertical at 3 m

Frequency (MHz)	Emission Level (dBuV/m)	Read Level (dBuV)	Limit (dBuV/m)	Margin (dB)	Antenna Factor (dB/m)	Cable Loss (dB)	Preamp Factor (dB)	Antenna Height (cm)	Table Angle (Degree)	Remark
5146.7	42.68	34.43	54	-11.32	34.12	8.13	34	100	213	Average
5146.7	53.13	44.88	74	-20.87	34.12	8.13	34	100	213	Peak
5180	94.56	86.25			34.15	8.16	34	100	213	Average
5180	101.95	93.64			34.15	8.16	34	100	213	Peak
*10360	56.88	42.58	68.2	-11.32	37.12	12.3	35.12	102	1	Peak

Remarks:

- Emission Level = Read Level + Antenna Factor + Cable Loss - Preamp Factor
Margin value = Emission level – Limit value
- 5180 MHz: Fundamental Frequency
- *: Out of Restricted Band
- The emission levels of other frequencies were very low against the limit

EUT Test Condition		Measurement Detail	
Channel	Channel 40	Frequency Range	1 GHz ~ 40 GHz
Input Power	120 Vac, 60 Hz	Detector Function	Peak (PK) Average (AV)
Environmental Conditions	25 deg. C, 65 % RH	Tested By	Charles Hsiao

Antenna Polarity & Test Distance: Horizontal at 3 m										
Frequency (MHz)	Emission Level (dBuV/m)	Read Level (dBuV)	Limit (dBuV/m)	Margin (dB)	Antenna Factor (dB/m)	Cable Loss (dB)	Preamp Factor (dB)	Antenna Height (cm)	Table Angle (Degree)	Remark
5150	44.13	35.88	54	-9.87	34.12	8.13	34	100	170	Average
5150	54.95	46.7	74	-19.05	34.12	8.13	34	100	170	Peak
5200	99.98	91.63			34.16	8.19	34	100	170	Average
5200	106.75	98.4			34.16	8.19	34	100	170	Peak
5443.94	42.4	33.61	54	-11.6	34.35	8.48	34.04	100	170	Average
5443.94	53.47	44.68	74	-20.53	34.35	8.48	34.04	100	170	Peak
*10400	55.03	40.69	68.2	-13.17	37.14	12.36	35.16	124	155	Peak
Antenna Polarity & Test Distance: Vertical at 3 m										
Frequency (MHz)	Emission Level (dBuV/m)	Read Level (dBuV)	Limit (dBuV/m)	Margin (dB)	Antenna Factor (dB/m)	Cable Loss (dB)	Preamp Factor (dB)	Antenna Height (cm)	Table Angle (Degree)	Remark
5147.75	42.91	34.66	54	-11.09	34.12	8.13	34	100	213	Average
5147.75	53.56	45.31	74	-20.44	34.12	8.13	34	100	213	Peak
5200	95.88	87.53			34.16	8.19	34	100	213	Average
5200	102.98	94.63			34.16	8.19	34	100	213	Peak
5449.55	42.4	33.57	54	-11.6	34.36	8.51	34.04	100	213	Average
5449.55	53.73	44.9	74	-20.27	34.36	8.51	34.04	100	213	Peak
*10400	55.99	41.65	68.2	-12.21	37.14	12.36	35.16	114	359	Peak

Remarks:

- Emission Level = Read Level + Antenna Factor + Cable Loss - Preamp Factor
Margin value = Emission level – Limit value
- 5200 MHz: Fundamental Frequency
- *: Out of Restricted Band
- The emission levels of other frequencies were very low against the limit

EUT Test Condition		Measurement Detail	
Channel	Channel 48	Frequency Range	1 GHz ~ 40 GHz
Input Power	120 Vac, 60 Hz	Detector Function	Peak (PK) Average (AV)
Environmental Conditions	25 deg. C, 65 % RH	Tested By	Charles Hsiao

Antenna Polarity & Test Distance: Horizontal at 3 m										
Frequency (MHz)	Emission Level (dBuV/m)	Read Level (dBuV)	Limit (dBuV/m)	Margin (dB)	Antenna Factor (dB/m)	Cable Loss (dB)	Preamp Factor (dB)	Antenna Height (cm)	Table Angle (Degree)	Remark
5240	95.63	87.19			34.19	8.26	34.01	100	213	Average
5240	102.2	93.76			34.19	8.26	34.01	100	213	Peak
5446.03	42.39	33.56	54	-11.61	34.36	8.51	34.04	100	213	Average
5446.03	52.84	44.01	74	-21.16	34.36	8.51	34.04	100	213	Peak
*10480	55.79	41.28	68.2	-12.41	37.19	12.53	35.21	119	144	Peak
Antenna Polarity & Test Distance: Vertical at 3 m										
Frequency (MHz)	Emission Level (dBuV/m)	Read Level (dBuV)	Limit (dBuV/m)	Margin (dB)	Antenna Factor (dB/m)	Cable Loss (dB)	Preamp Factor (dB)	Antenna Height (cm)	Table Angle (Degree)	Remark
5240	99.78	91.34			34.19	8.26	34.01	100	170	Average
5240	106.25	97.81			34.19	8.26	34.01	100	170	Peak
5459.34	42.5	33.68	54	-11.5	34.36	8.51	34.05	100	170	Average
5459.34	53.55	44.73	74	-20.45	34.36	8.51	34.05	100	170	Peak
*10480	55.4	40.89	68.2	-12.8	37.19	12.53	35.21	119	134	Peak

Remarks:

- Emission Level = Read Level + Antenna Factor + Cable Loss - Preamp Factor
Margin value = Emission level – Limit value
- 5240 MHz: Fundamental Frequency
- *: Out of Restricted Band
- The emission levels of other frequencies were very low against the limit

EUT Test Condition		Measurement Detail	
Channel	Channel 52	Frequency Range	1 GHz ~ 40 GHz
Input Power	120 Vac, 60 Hz	Detector Function	Peak (PK) Average (AV)
Environmental Conditions	25 deg. C, 65 % RH	Tested By	Charles Hsiao

Antenna Polarity & Test Distance: Horizontal at 3 m										
Frequency (MHz)	Emission Level (dBuV/m)	Read Level (dBuV)	Limit (dBuV/m)	Margin (dB)	Antenna Factor (dB/m)	Cable Loss (dB)	Preamp Factor (dB)	Antenna Height (cm)	Table Angle (Degree)	Remark
5129.9	42.39	34.17	54	-11.61	34.11	8.1	33.99	123	182	Average
5129.9	53.02	44.8	74	-20.98	34.11	8.1	33.99	123	182	Peak
5260	100.47	92.01			34.21	8.26	34.01	123	182	Average
5260	107.32	98.86			34.21	8.26	34.01	123	182	Peak
*10520	55.59	41	68.2	-12.61	37.21	12.61	35.23	124	5	Peak

Antenna Polarity & Test Distance: Vertical at 3 m										
Frequency (MHz)	Emission Level (dBuV/m)	Read Level (dBuV)	Limit (dBuV/m)	Margin (dB)	Antenna Factor (dB/m)	Cable Loss (dB)	Preamp Factor (dB)	Antenna Height (cm)	Table Angle (Degree)	Remark
5149.55	42.32	34.07	54	-11.68	34.12	8.13	34	100	194	Average
5149.55	53.5	45.25	74	-20.5	34.12	8.13	34	100	194	Peak
5260	95.47	87.01			34.21	8.26	34.01	100	194	Average
5260	102.07	93.61			34.21	8.26	34.01	100	194	Peak
*10520	55.16	40.57	68.2	-13.04	37.21	12.61	35.23	121	213	Peak

Remarks:

- Emission Level = Read Level + Antenna Factor + Cable Loss - Preamp Factor
Margin value = Emission level – Limit value
- 5260 MHz: Fundamental Frequency
- *: Out of Restricted Band
- The emission levels of other frequencies were very low against the limit

EUT Test Condition		Measurement Detail	
Channel	Channel 60	Frequency Range	1 GHz ~ 40 GHz
Input Power	120 Vac, 60 Hz	Detector Function	Peak (PK) Average (AV)
Environmental Conditions	25 deg. C, 65 % RH	Tested By	Charles Hsiao

Antenna Polarity & Test Distance: Horizontal at 3 m										
Frequency (MHz)	Emission Level (dBuV/m)	Read Level (dBuV)	Limit (dBuV/m)	Margin (dB)	Antenna Factor (dB/m)	Cable Loss (dB)	Preamp Factor (dB)	Antenna Height (cm)	Table Angle (Degree)	Remark
5064.5	42.34	34.24	54	-11.66	34.05	8.03	33.98	123	182	Average
5064.5	52.99	44.89	74	-21.01	34.05	8.03	33.98	123	182	Peak
5300	100.43	91.89			34.24	8.32	34.02	123	182	Average
5300	107.25	98.71			34.24	8.32	34.02	123	182	Peak
5358.69	44.53	35.9	54	-9.47	34.28	8.38	34.03	123	182	Average
5358.69	54.2	45.57	74	-19.8	34.28	8.38	34.03	123	182	Peak
10600	46.67	31.99	54	-7.33	37.28	12.67	35.27	124	11	Average
10600	56.35	41.67	74	-17.65	37.28	12.67	35.27	124	11	Peak

Antenna Polarity & Test Distance: Vertical at 3 m										
Frequency (MHz)	Emission Level (dBuV/m)	Read Level (dBuV)	Limit (dBuV/m)	Margin (dB)	Antenna Factor (dB/m)	Cable Loss (dB)	Preamp Factor (dB)	Antenna Height (cm)	Table Angle (Degree)	Remark
5111.45	42.33	34.13	54	-11.67	34.09	8.1	33.99	100	194	Average
5111.45	52.85	44.65	74	-21.15	34.09	8.1	33.99	100	194	Peak
5300	96.19	87.65			34.24	8.32	34.02	100	194	Average
5300	103.47	94.93			34.24	8.32	34.02	100	194	Peak
5354.4	43.3	34.67	54	-10.7	34.28	8.38	34.03	100	194	Average
5354.4	53.87	45.24	74	-20.13	34.28	8.38	34.03	100	194	Peak
10600	46.63	31.95	54	-7.37	37.28	12.67	35.27	124	274	Average
10600	56.17	41.49	74	-17.83	37.28	12.67	35.27	124	274	Peak

Remarks:

- Emission Level = Read Level + Antenna Factor + Cable Loss - Preamp Factor
Margin value = Emission level – Limit value
- 5300 MHz: Fundamental Frequency
- The emission levels of other frequencies were very low against the limit

EUT Test Condition		Measurement Detail	
Channel	Channel 64	Frequency Range	1 GHz ~ 40 GHz
Input Power	120 Vac, 60 Hz	Detector Function	Peak (PK) Average (AV)
Environmental Conditions	25 deg. C, 65 % RH	Tested By	Charles Hsiao

Antenna Polarity & Test Distance: Horizontal at 3 m										
Frequency (MHz)	Emission Level (dBuV/m)	Read Level (dBuV)	Limit (dBuV/m)	Margin (dB)	Antenna Factor (dB/m)	Cable Loss (dB)	Preamp Factor (dB)	Antenna Height (cm)	Table Angle (Degree)	Remark
5320	99.82	91.24			34.25	8.35	34.02	123	182	Average
5320	106.39	97.81			34.25	8.35	34.02	123	182	Peak
5352.2	43.81	35.18	54	-10.19	34.28	8.38	34.03	123	182	Average
5352.2	54.35	45.72	74	-19.65	34.28	8.38	34.03	123	182	Peak
10640	46.86	32.13	54	-7.14	37.31	12.71	35.29	154	7	Average
10640	55.25	40.52	74	-18.75	37.31	12.71	35.29	154	7	Peak

Antenna Polarity & Test Distance: Vertical at 3 m										
Frequency (MHz)	Emission Level (dBuV/m)	Read Level (dBuV)	Limit (dBuV/m)	Margin (dB)	Antenna Factor (dB/m)	Cable Loss (dB)	Preamp Factor (dB)	Antenna Height (cm)	Table Angle (Degree)	Remark
5320	95.74	87.16			34.25	8.35	34.02	100	194	Average
5320	102.72	94.14			34.25	8.35	34.02	100	194	Peak
5367.38	43.09	34.42	54	-10.91	34.29	8.41	34.03	100	194	Average
5367.38	53.74	45.07	74	-20.26	34.29	8.41	34.03	100	194	Peak
10640	46.74	32.01	54	-7.26	37.31	12.71	35.29	134	310	Average
10640	55.71	40.98	74	-18.29	37.31	12.71	35.29	134	310	Peak

Remarks:

- Emission Level = Read Level + Antenna Factor + Cable Loss - Preamp Factor
Margin value = Emission level – Limit value
- 5320 MHz: Fundamental Frequency
- The emission levels of other frequencies were very low against the limit

EUT Test Condition		Measurement Detail	
Channel	Channel 100	Frequency Range	1 GHz ~ 40 GHz
Input Power	120 Vac, 60 Hz	Detector Function	Peak (PK) Average (AV)
Environmental Conditions	25 deg. C, 65 % RH	Tested By	Karl Lee

Antenna Polarity & Test Distance: Horizontal at 3 m										
Frequency (MHz)	Emission Level (dBuV/m)	Read Level (dBuV)	Limit (dBuV/m)	Margin (dB)	Antenna Factor (dB/m)	Cable Loss (dB)	Preamp Factor (dB)	Antenna Height (cm)	Table Angle (Degree)	Remark
5456.08	42.78	33.96	54	-11.22	34.36	8.51	34.05	251	269	Average
5456.08	53.78	44.96	74	-20.22	34.36	8.51	34.05	251	269	Peak
*5468.4	51.52	42.69	68.2	-16.68	34.37	8.51	34.05	251	269	Peak
5500	89.55	80.63			34.4	8.57	34.05	251	269	Average
5500	96.99	88.07			34.4	8.57	34.05	251	269	Peak
11000	47.2	32.12	54	-6.8	37.6	12.96	35.48	102	154	Average
11000	57	41.92	74	-17	37.6	12.96	35.48	102	154	Peak
Antenna Polarity & Test Distance: Vertical at 3 m										
Frequency (MHz)	Emission Level (dBuV/m)	Read Level (dBuV)	Limit (dBuV/m)	Margin (dB)	Antenna Factor (dB/m)	Cable Loss (dB)	Preamp Factor (dB)	Antenna Height (cm)	Table Angle (Degree)	Remark
5458.8	43.55	34.73	54	-10.45	34.36	8.51	34.05	102	150	Average
5458.8	53.75	44.93	74	-20.25	34.36	8.51	34.05	102	150	Peak
*5469.04	52.76	43.93	68.2	-15.44	34.37	8.51	34.05	102	150	Peak
5500	94.49	85.57			34.4	8.57	34.05	102	150	Average
5500	102.23	93.31			34.4	8.57	34.05	102	150	Peak
11000	47.49	32.41	54	-6.51	37.6	12.96	35.48	125	195	Average
11000	56.31	41.23	74	-17.69	37.6	12.96	35.48	125	195	Peak

Remarks:

- Emission Level = Read Level + Antenna Factor + Cable Loss - Preamp Factor
Margin value = Emission level – Limit value
- 5500 MHz: Fundamental Frequency
- *: Out of Restricted Band
- The emission levels of other frequencies were very low against the limit

EUT Test Condition		Measurement Detail	
Channel	Channel 116	Frequency Range	1 GHz ~ 40 GHz
Input Power	120 Vac, 60 Hz	Detector Function	Peak (PK) Average (AV)
Environmental Conditions	25 deg. C, 65 % RH	Tested By	Karl Lee

Antenna Polarity & Test Distance: Horizontal at 3 m										
Frequency (MHz)	Emission Level (dBuV/m)	Read Level (dBuV)	Limit (dBuV/m)	Margin (dB)	Antenna Factor (dB/m)	Cable Loss (dB)	Preamp Factor (dB)	Antenna Height (cm)	Table Angle (Degree)	Remark
5458.96	42.71	33.89	54	-11.29	34.36	8.51	34.05	251	269	Average
5458.96	53.54	44.72	74	-20.46	34.36	8.51	34.05	251	269	Peak
*5470.8	52.62	43.76	68.2	-15.58	34.37	8.54	34.05	251	269	Peak
5580	95.22	86.23			34.47	8.6	34.08	251	269	Average
5580	102.56	93.57			34.47	8.6	34.08	251	269	Peak
*5725.96	52.47	43.31	68.2	-15.73	34.62	8.65	34.11	251	269	Peak
11160	47.65	32.57	54	-6.35	37.7	12.83	35.45	122	165	Average
11160	56.66	41.58	74	-17.34	37.7	12.83	35.45	122	165	Peak

Antenna Polarity & Test Distance: Vertical at 3 m										
Frequency (MHz)	Emission Level (dBuV/m)	Read Level (dBuV)	Limit (dBuV/m)	Margin (dB)	Antenna Factor (dB/m)	Cable Loss (dB)	Preamp Factor (dB)	Antenna Height (cm)	Table Angle (Degree)	Remark
5450.64	42.91	34.09	54	-11.09	34.36	8.51	34.05	103	150	Average
5450.64	54.34	45.52	74	-19.66	34.36	8.51	34.05	103	150	Peak
*5470.96	53.42	44.56	68.2	-14.78	34.37	8.54	34.05	103	150	Peak
5580	99.5	90.51			34.47	8.6	34.08	103	150	Average
5580	107.28	98.29			34.47	8.6	34.08	103	150	Peak
*5725.56	53.73	44.57	68.2	-14.47	34.62	8.65	34.11	103	150	Peak
11160	47.61	32.53	54	-6.39	37.7	12.83	35.45	101	147	Average
11160	56.72	41.64	74	-17.28	37.7	12.83	35.45	101	147	Peak

Remarks:

- Emission Level = Read Level + Antenna Factor + Cable Loss - Preamp Factor
Margin value = Emission level – Limit value
- 5580 MHz: Fundamental Frequency
- *: Out of Restricted Band
- The emission levels of other frequencies were very low against the limit

EUT Test Condition		Measurement Detail	
Channel	Channel 140	Frequency Range	1 GHz ~ 40 GHz
Input Power	120 Vac, 60 Hz	Detector Function	Peak (PK) Average (AV)
Environmental Conditions	25 deg. C, 65 % RH	Tested By	Karl Lee

Antenna Polarity & Test Distance: Horizontal at 3 m										
Frequency (MHz)	Emission Level (dBuV/m)	Read Level (dBuV)	Limit (dBuV/m)	Margin (dB)	Antenna Factor (dB/m)	Cable Loss (dB)	Preamp Factor (dB)	Antenna Height (cm)	Table Angle (Degree)	Remark
5700	90	80.87			34.59	8.64	34.1	236	267	Average
5700	97.4	88.27			34.59	8.64	34.1	236	267	Peak
*5723.96	52.56	43.4	68.2	-15.64	34.62	8.65	34.11	236	267	Peak
11400	47.67	32.57	54	-6.33	37.84	12.67	35.41	122	132	Average
11400	57.04	41.94	74	-16.96	37.84	12.67	35.41	122	132	Peak

Antenna Polarity & Test Distance: Vertical at 3 m										
Frequency (MHz)	Emission Level (dBuV/m)	Read Level (dBuV)	Limit (dBuV/m)	Margin (dB)	Antenna Factor (dB/m)	Cable Loss (dB)	Preamp Factor (dB)	Antenna Height (cm)	Table Angle (Degree)	Remark
5700	94.13	85	54	40.13	34.59	8.64	34.1	106	183	Average
5700	101.73	92.6	74	27.73	34.59	8.64	34.1	106	183	Peak
*5725.56	54.35	45.19	68.2	-13.85	34.62	8.65	34.11	106	183	Peak
11400	47.73	32.63	54	-6.27	37.84	12.67	35.41	101	147	Average
11400	56.7	41.6	74	-17.3	37.84	12.67	35.41	101	147	Peak

Remarks:

- Emission Level = Read Level + Antenna Factor + Cable Loss - Preamp Factor
Margin value = Emission level – Limit value
- 5700 MHz: Fundamental Frequency
- *: Out of Restricted Band
- The emission levels of other frequencies were very low against the limit

EUT Test Condition		Measurement Detail	
Channel	Channel 149	Frequency Range	1 GHz ~ 40 GHz
Input Power	120 Vac, 60 Hz	Detector Function	Peak (PK) Average (AV)
Environmental Conditions	25 deg. C, 65 % RH	Tested By	Karl Lee

<Spurious Emission>

Antenna Polarity & Test Distance: Horizontal at 3 m										
Frequency (MHz)	Emission Level (dBuV/m)	Read Level (dBuV)	Limit (dBuV/m)	Margin (dB)	Antenna Factor (dB/m)	Cable Loss (dB)	Preamp Factor (dB)	Antenna Height (cm)	Table Angle (Degree)	Remark
5745	92.3	83.11			34.64	8.66	34.11	110	184	Average
5745	100.71	91.52			34.64	8.66	34.11	110	184	Peak
11490	47.08	31.96	54	-6.92	37.89	12.62	35.39	124	105	Average
11490	56.4	41.28	74	-17.6	37.89	12.62	35.39	124	105	Peak
Antenna Polarity & Test Distance: Vertical at 3 m										
Frequency (MHz)	Emission Level (dBuV/m)	Read Level (dBuV)	Limit (dBuV/m)	Margin (dB)	Antenna Factor (dB/m)	Cable Loss (dB)	Preamp Factor (dB)	Antenna Height (cm)	Table Angle (Degree)	Remark
5745	90.72	81.53			34.64	8.66	34.11	220	276	Average
5745	94.38	85.19			34.64	8.66	34.11	220	276	Peak
11490	47.2	32.08	54	-6.8	37.89	12.62	35.39	124	118	Average
11490	56.05	40.93	74	-17.95	37.89	12.62	35.39	124	118	Peak

<Out of Band Emission (OOBE)>

Antenna Polarity & Test Distance: Horizontal at 3 m										
Frequency (MHz)	Emission Level (dBuV/m)	Read Level (dBuV)	Limit (dBuV/m)	Margin (dB)	Antenna Factor (dB/m)	Cable Loss (dB)	Preamp Factor (dB)	Antenna Height (cm)	Table Angle (Degree)	Remark
*5524.675	53	44.06	68.2	-15.2	34.42	8.58	34.06	110	184	Peak
5652.25	50.83	41.74	69.86	-19.03	34.56	8.62	34.09	110	184	Peak
5922.625	50.79	41.39	69.96	-19.17	34.83	8.73	34.16	110	184	Peak
*6021.85	53.46	43.95	68.2	-14.74	34.92	8.77	34.18	110	184	Peak
Antenna Polarity & Test Distance: Vertical at 3 m										
Frequency (MHz)	Emission Level (dBuV/m)	Read Level (dBuV)	Limit (dBuV/m)	Margin (dB)	Antenna Factor (dB/m)	Cable Loss (dB)	Preamp Factor (dB)	Antenna Height (cm)	Table Angle (Degree)	Remark
*5593.45	53.11	44.1	68.2	-15.09	34.49	8.6	34.08	220	276	Peak
5654.35	52.13	43.04	71.42	-19.29	34.56	8.63	34.1	220	276	Peak
5922.625	51.92	42.52	69.96	-18.04	34.83	8.73	34.16	220	276	Peak
*5968.825	53.22	43.77	68.2	-14.98	34.87	8.75	34.17	220	276	Peak

Remarks:

- Emission Level = Read Level + Antenna Factor + Cable Loss - Preamp Factor
Margin value = Emission level – Limit value
- 5745 MHz: Fundamental Frequency
- *: Out of Restricted Band
- The emission levels of other frequencies were very low against the limit

EUT Test Condition		Measurement Detail	
Channel	Channel 157	Frequency Range	1 GHz ~ 40 GHz
Input Power	120 Vac, 60 Hz	Detector Function	Peak (PK) Average (AV)
Environmental Conditions	25 deg. C, 65 % RH	Tested By	Karl Lee

<Spurious Emission>

Antenna Polarity & Test Distance: Horizontal at 3 m										
Frequency (MHz)	Emission Level (dBuV/m)	Read Level (dBuV)	Limit (dBuV/m)	Margin (dB)	Antenna Factor (dB/m)	Cable Loss (dB)	Preamp Factor (dB)	Antenna Height (cm)	Table Angle (Degree)	Remark
5785	98.59	89.36			34.68	8.68	34.13	110	184	Average
5785	106.48	97.25			34.68	8.68	34.13	110	184	Peak
11570	47.25	31.94	54	-6.75	38	12.68	35.37	158	14	Average
11570	56.66	41.35	74	-17.34	38	12.68	35.37	158	14	Peak
Antenna Polarity & Test Distance: Vertical at 3 m										
Frequency (MHz)	Emission Level (dBuV/m)	Read Level (dBuV)	Limit (dBuV/m)	Margin (dB)	Antenna Factor (dB/m)	Cable Loss (dB)	Preamp Factor (dB)	Antenna Height (cm)	Table Angle (Degree)	Remark
5785	93.89	84.66			34.68	8.68	34.13	220	276	Average
5785	101.26	92.03			34.68	8.68	34.13	220	276	Peak
11570	47.46	32.15	54	-6.54	38	12.68	35.37	134	229	Average
11570	56.79	41.48	74	-17.21	38	12.68	35.37	134	229	Peak

<Out of Band Emission (OOBE)>

Antenna Polarity & Test Distance: Horizontal at 3 m										
Frequency (MHz)	Emission Level (dBuV/m)	Read Level (dBuV)	Limit (dBuV/m)	Margin (dB)	Antenna Factor (dB/m)	Cable Loss (dB)	Preamp Factor (dB)	Antenna Height (cm)	Table Angle (Degree)	Remark
*5593.975	53.81	44.8	68.2	-14.39	34.49	8.6	34.08	110	184	Peak
5653.3	51.15	42.05	70.64	-19.49	34.56	8.63	34.09	110	184	Peak
5923.15	51.49	42.09	69.57	-18.08	34.83	8.73	34.16	110	184	Peak
*5929.975	53.82	44.42	68.2	-14.38	34.83	8.73	34.16	110	184	Peak
Antenna Polarity & Test Distance: Vertical at 3 m										
Frequency (MHz)	Emission Level (dBuV/m)	Read Level (dBuV)	Limit (dBuV/m)	Margin (dB)	Antenna Factor (dB/m)	Cable Loss (dB)	Preamp Factor (dB)	Antenna Height (cm)	Table Angle (Degree)	Remark
*5590.825	53.8	44.79	68.2	-14.4	34.49	8.6	34.08	220	276	Peak
5652.775	51.71	42.61	70.25	-18.54	34.56	8.63	34.09	220	276	Peak
5923.15	51.23	41.83	69.57	-18.34	34.83	8.73	34.16	220	276	Peak
*5994.55	53.12	43.63	68.2	-15.08	34.9	8.76	34.17	220	276	Peak

Remarks:

- Emission Level = Read Level + Antenna Factor + Cable Loss - Preamp Factor
Margin value = Emission level – Limit value
- 5785 MHz: Fundamental Frequency
- *: Out of Restricted Band
- The emission levels of other frequencies were very low against the limit

EUT Test Condition		Measurement Detail	
Channel	Channel 165	Frequency Range	1 GHz ~ 40 GHz
Input Power	120 Vac, 60 Hz	Detector Function	Peak (PK) Average (AV)
Environmental Conditions	25 deg. C, 65 % RH	Tested By	Karl Lee

<Spurious Emission>

Antenna Polarity & Test Distance: Horizontal at 3 m										
Frequency (MHz)	Emission Level (dBuV/m)	Read Level (dBuV)	Limit (dBuV/m)	Margin (dB)	Antenna Factor (dB/m)	Cable Loss (dB)	Preamp Factor (dB)	Antenna Height (cm)	Table Angle (Degree)	Remark
5825	96.57	87.28			34.73	8.69	34.13	140	184	Average
5825	104.1	94.81			34.73	8.69	34.13	140	184	Peak
11650	46.97	31.44	54	-7.03	38.09	12.8	35.36	124	311	Average
11650	55.88	40.35	74	-18.12	38.09	12.8	35.36	124	311	Peak
Antenna Polarity & Test Distance: Vertical at 3 m										
Frequency (MHz)	Emission Level (dBuV/m)	Read Level (dBuV)	Limit (dBuV/m)	Margin (dB)	Antenna Factor (dB/m)	Cable Loss (dB)	Preamp Factor (dB)	Antenna Height (cm)	Table Angle (Degree)	Remark
5825	90.4	81.11			34.73	8.69	34.13	220	276	Average
5825	97.92	88.63			34.73	8.69	34.13	220	276	Peak
11650	47.73	32.2	54	-6.27	38.09	12.8	35.36	134	326	Average
11650	55.47	39.94	74	-18.53	38.09	12.8	35.36	134	326	Peak

<Out of Band Emission (OOBE)>

Antenna Polarity & Test Distance: Horizontal at 3 m										
Frequency (MHz)	Emission Level (dBuV/m)	Read Level (dBuV)	Limit (dBuV/m)	Margin (dB)	Antenna Factor (dB/m)	Cable Loss (dB)	Preamp Factor (dB)	Antenna Height (cm)	Table Angle (Degree)	Remark
*5636.5	53.15	44.08	68.2	-15.05	34.54	8.62	34.09	140	184	Peak
5652.25	51.64	42.55	69.86	-18.22	34.56	8.62	34.09	140	184	Peak
5922.1	51.4	42	70.35	-18.95	34.83	8.73	34.16	140	184	Peak
*6024.475	53.81	44.29	68.2	-14.39	34.93	8.77	34.18	140	184	Peak
Antenna Polarity & Test Distance: Vertical at 3 m										
Frequency (MHz)	Emission Level (dBuV/m)	Read Level (dBuV)	Limit (dBuV/m)	Margin (dB)	Antenna Factor (dB/m)	Cable Loss (dB)	Preamp Factor (dB)	Antenna Height (cm)	Table Angle (Degree)	Remark
*5611.3	54.75	45.72	68.2	-13.45	34.5	8.61	34.08	220	276	Peak
5653.3	51.36	42.26	70.64	-19.28	34.56	8.63	34.09	220	276	Peak
5922.625	51.76	42.36	69.96	-18.2	34.83	8.73	34.16	220	276	Peak
*6017.65	53.65	44.14	68.2	-14.55	34.92	8.77	34.18	220	276	Peak

Remarks:

- Emission Level = Read Level + Antenna Factor + Cable Loss - Preamp Factor
Margin value = Emission level – Limit value
- 5825 MHz: Fundamental Frequency
- *: Out of Restricted Band
- The emission levels of other frequencies were very low against the limit

802.11n (HT40)

EUT Test Condition		Measurement Detail	
Channel	Channel 38	Frequency Range	1 GHz ~ 40 GHz
Input Power	120 Vac, 60 Hz	Detector Function	Peak (PK) Average (AV)
Environmental Conditions	25 deg. C, 65 % RH	Tested By	Charles Hsiao

Antenna Polarity & Test Distance: Horizontal at 3 m

Frequency (MHz)	Emission Level (dBuV/m)	Read Level (dBuV)	Limit (dBuV/m)	Margin (dB)	Antenna Factor (dB/m)	Cable Loss (dB)	Preamp Factor (dB)	Antenna Height (cm)	Table Angle (Degree)	Remark
5150	44.64	36.39	54	-9.36	34.12	8.13	34	100	170	Average
5150	53.44	45.19	74	-20.56	34.12	8.13	34	100	170	Peak
5190	92.57	84.23			34.15	8.19	34	100	170	Average
5190	99.26	90.92			34.15	8.19	34	100	170	Peak
5421.06	42.8	34.03	54	-11.2	34.33	8.48	34.04	100	170	Average
5421.06	52.93	44.16	74	-21.07	34.33	8.48	34.04	100	170	Peak
*10380	55.36	41.01	68.2	-12.84	37.13	12.36	35.14	187	114	Peak

Antenna Polarity & Test Distance: Vertical at 3 m

Frequency (MHz)	Emission Level (dBuV/m)	Read Level (dBuV)	Limit (dBuV/m)	Margin (dB)	Antenna Factor (dB/m)	Cable Loss (dB)	Preamp Factor (dB)	Antenna Height (cm)	Table Angle (Degree)	Remark
5133.65	42.88	34.63	54	-11.12	34.11	8.13	33.99	100	213	Average
5133.65	52.68	44.43	74	-21.32	34.11	8.13	33.99	100	213	Peak
5190	88.53	80.19			34.15	8.19	34	100	213	Average
5190	95.43	87.09			34.15	8.19	34	100	213	Peak
5422.16	42.77	34	54	-11.23	34.33	8.48	34.04	100	213	Average
5422.16	53.15	44.38	74	-20.85	34.33	8.48	34.04	100	213	Peak
*10380	55.63	41.28	68.2	-12.57	37.13	12.36	35.14	113	300	Peak

Remarks:

- Emission Level = Read Level + Antenna Factor + Cable Loss - Preamp Factor
Margin value = Emission level – Limit value
- 5190 MHz: Fundamental Frequency
- *: Out of Restricted Band
- The emission levels of other frequencies were very low against the limit

EUT Test Condition		Measurement Detail	
Channel	Channel 46	Frequency Range	1 GHz ~ 40 GHz
Input Power	120 Vac, 60 Hz	Detector Function	Peak (PK) Average (AV)
Environmental Conditions	25 deg. C, 65 % RH	Tested By	Charles Hsiao

Antenna Polarity & Test Distance: Horizontal at 3 m										
Frequency (MHz)	Emission Level (dBuV/m)	Read Level (dBuV)	Limit (dBuV/m)	Margin (dB)	Antenna Factor (dB/m)	Cable Loss (dB)	Preamp Factor (dB)	Antenna Height (cm)	Table Angle (Degree)	Remark
5150	44.06	35.81	54	-9.94	34.12	8.13	34	100	170	Average
5150	53.65	45.4	74	-20.35	34.12	8.13	34	100	170	Peak
5230	94.65	86.25			34.19	8.22	34.01	100	170	Average
5230	101.34	92.94			34.19	8.22	34.01	100	170	Peak
5364.52	43.15	34.51	54	-10.85	34.29	8.38	34.03	100	170	Average
5364.52	53.76	45.12	74	-20.24	34.29	8.38	34.03	100	170	Peak
*10460	55.25	40.74	68.2	-12.95	37.17	12.53	35.19	159	322	Peak
Antenna Polarity & Test Distance: Vertical at 3 m										
Frequency (MHz)	Emission Level (dBuV/m)	Read Level (dBuV)	Limit (dBuV/m)	Margin (dB)	Antenna Factor (dB/m)	Cable Loss (dB)	Preamp Factor (dB)	Antenna Height (cm)	Table Angle (Degree)	Remark
5123.75	42.73	34.51	54	-11.27	34.11	8.1	33.99	100	213	Average
5123.75	52.64	44.42	74	-21.36	34.11	8.1	33.99	100	213	Peak
5230	90.54	82.14			34.19	8.22	34.01	100	213	Average
5230	97.61	89.21			34.19	8.22	34.01	100	213	Peak
5455.38	42.91	34.09	54	-11.09	34.36	8.51	34.05	100	213	Average
5455.38	53.24	44.42	74	-20.76	34.36	8.51	34.05	100	213	Peak
*10460	56.17	41.66	68.2	-12.03	37.17	12.53	35.19	180	16	Peak

Remarks:

- Emission Level = Read Level + Antenna Factor + Cable Loss - Preamp Factor
Margin value = Emission level – Limit value
- 5230 MHz: Fundamental Frequency
- *: Out of Restricted Band
- The emission levels of other frequencies were very low against the limit

EUT Test Condition		Measurement Detail	
Channel	Channel 54	Frequency Range	1 GHz ~ 40 GHz
Input Power	120 Vac, 60 Hz	Detector Function	Peak (PK) Average (AV)
Environmental Conditions	25 deg. C, 65 % RH	Tested By	Charles Hsiao

Antenna Polarity & Test Distance: Horizontal at 3 m										
Frequency (MHz)	Emission Level (dBuV/m)	Read Level (dBuV)	Limit (dBuV/m)	Margin (dB)	Antenna Factor (dB/m)	Cable Loss (dB)	Preamp Factor (dB)	Antenna Height (cm)	Table Angle (Degree)	Remark
5145.65	42.93	34.68	54	-11.07	34.12	8.13	34	123	182	Average
5145.65	53.72	45.47	74	-20.28	34.12	8.13	34	123	182	Peak
5270	94.65	86.16			34.21	8.29	34.01	123	182	Average
5270	101.65	93.16			34.21	8.29	34.01	123	182	Peak
5352.2	43.38	34.75	54	-10.62	34.28	8.38	34.03	123	182	Average
5352.2	53.42	44.79	74	-20.58	34.28	8.38	34.03	123	182	Peak
*10540	55.86	41.24	68.2	-12.34	37.23	12.63	35.24	132	5	Peak
Antenna Polarity & Test Distance: Vertical at 3 m										
Frequency (MHz)	Emission Level (dBuV/m)	Read Level (dBuV)	Limit (dBuV/m)	Margin (dB)	Antenna Factor (dB/m)	Cable Loss (dB)	Preamp Factor (dB)	Antenna Height (cm)	Table Angle (Degree)	Remark
5129.75	42.76	34.54	54	-11.24	34.11	8.1	33.99	100	194	Average
5129.75	52.92	44.7	74	-21.08	34.11	8.1	33.99	100	194	Peak
5270	90.53	82.04			34.21	8.29	34.01	100	194	Average
5270	97.91	89.42			34.21	8.29	34.01	100	194	Peak
5361.22	43.09	34.45	54	-10.91	34.29	8.38	34.03	100	194	Average
5361.22	53.7	45.06	74	-20.3	34.29	8.38	34.03	100	194	Peak
*10540	55.64	41.02	68.2	-12.56	37.23	12.63	35.24	115	74	Peak

Remarks:

- Emission Level = Read Level + Antenna Factor + Cable Loss - Preamp Factor
Margin value = Emission level – Limit value
- 5270 MHz: Fundamental Frequency
- *: Out of Restricted Band
- The emission levels of other frequencies were very low against the limit

EUT Test Condition		Measurement Detail	
Channel	Channel 62	Frequency Range	1 GHz ~ 40 GHz
Input Power	120 Vac, 60 Hz	Detector Function	Peak (PK) Average (AV)
Environmental Conditions	25 deg. C, 65 % RH	Tested By	Charles Hsiao

Antenna Polarity & Test Distance: Horizontal at 3 m										
Frequency (MHz)	Emission Level (dBuV/m)	Read Level (dBuV)	Limit (dBuV/m)	Margin (dB)	Antenna Factor (dB/m)	Cable Loss (dB)	Preamp Factor (dB)	Antenna Height (cm)	Table Angle (Degree)	Remark
5134.85	42.77	34.52	54	-11.23	34.11	8.13	33.99	123	182	Average
5134.85	53.04	44.79	74	-20.96	34.11	8.13	33.99	123	182	Peak
5310	92.56	84.01			34.25	8.32	34.02	123	182	Average
5310	99.41	90.86			34.25	8.32	34.02	123	182	Peak
5352.64	43.64	35.01	54	-10.36	34.28	8.38	34.03	123	182	Average
5352.64	54.15	45.52	74	-19.85	34.28	8.38	34.03	123	182	Peak
10620	46.7	31.99	54	-7.3	37.3	12.69	35.28	124	1	Average
10620	55.09	40.38	74	-18.91	37.3	12.69	35.28	124	1	Peak

Antenna Polarity & Test Distance: Vertical at 3 m										
Frequency (MHz)	Emission Level (dBuV/m)	Read Level (dBuV)	Limit (dBuV/m)	Margin (dB)	Antenna Factor (dB/m)	Cable Loss (dB)	Preamp Factor (dB)	Antenna Height (cm)	Table Angle (Degree)	Remark
5143.85	42.74	34.49	54	-11.26	34.12	8.13	34	100	194	Average
5143.85	53.14	44.89	74	-20.86	34.12	8.13	34	100	194	Peak
5310	88.58	80.03			34.25	8.32	34.02	100	194	Average
5310	95.46	86.91			34.25	8.32	34.02	100	194	Peak
5352.31	42.99	34.36	54	-11.01	34.28	8.38	34.03	100	194	Average
5352.31	53.3	44.67	74	-20.7	34.28	8.38	34.03	100	194	Peak
10620	46.75	32.04	54	-7.25	37.3	12.69	35.28	112	34	Average
10620	57.05	42.34	74	-16.95	37.3	12.69	35.28	112	34	Peak

Remarks:

- Emission Level = Read Level + Antenna Factor + Cable Loss - Preamp Factor
Margin value = Emission level – Limit value
- 5310 MHz: Fundamental Frequency
- The emission levels of other frequencies were very low against the limit

EUT Test Condition		Measurement Detail	
Channel	Channel 102	Frequency Range	1 GHz ~ 40 GHz
Input Power	120 Vac, 60 Hz	Detector Function	Peak (PK) Average (AV)
Environmental Conditions	25 deg. C, 65 % RH	Tested By	Karl Lee

Antenna Polarity & Test Distance: Horizontal at 3 m										
Frequency (MHz)	Emission Level (dBuV/m)	Read Level (dBuV)	Limit (dBuV/m)	Margin (dB)	Antenna Factor (dB/m)	Cable Loss (dB)	Preamp Factor (dB)	Antenna Height (cm)	Table Angle (Degree)	Remark
5460.08	43.6	34.78	54	-10.4	34.36	8.51	34.05	100	150	Average
5460.08	53.78	44.96	74	-20.22	34.36	8.51	34.05	100	150	Peak
*5470.32	53.33	44.5	68.2	-14.87	34.37	8.51	34.05	100	150	Peak
5510	88.9	79.99			34.4	8.57	34.06	100	150	Average
5510	96.21	87.3			34.4	8.57	34.06	100	150	Peak
*5723.96	53.4	44.24	68.2	-14.8	34.62	8.65	34.11	100	150	Peak
11020	47.2	32.13	54	-6.8	37.61	12.94	35.48	133	165	Average
11020	56.91	41.84	74	-17.09	37.61	12.94	35.48	133	165	Peak

Antenna Polarity & Test Distance: Vertical at 3 m										
Frequency (MHz)	Emission Level (dBuV/m)	Read Level (dBuV)	Limit (dBuV/m)	Margin (dB)	Antenna Factor (dB/m)	Cable Loss (dB)	Preamp Factor (dB)	Antenna Height (cm)	Table Angle (Degree)	Remark
5455.92	43.23	34.41	54	-10.77	34.36	8.51	34.05	251	269	Average
5455.92	53.93	45.11	74	-20.07	34.36	8.51	34.05	251	269	Peak
*5469.36	52.93	44.1	68.2	-15.27	34.37	8.51	34.05	251	269	Peak
5510	84.19	75.28			34.4	8.57	34.06	251	269	Average
5510	91.27	82.36			34.4	8.57	34.06	251	269	Peak
*5726.04	53.26	44.1	68.2	-14.94	34.62	8.65	34.11	251	269	Peak
11020	47.31	32.24	54	-6.69	37.61	12.94	35.48	166	195	Average
11020	56.14	41.07	74	-17.86	37.61	12.94	35.48	166	195	Peak

Remarks:

- Emission Level = Read Level + Antenna Factor + Cable Loss - Preamp Factor
Margin value = Emission level – Limit value
- 5510 MHz: Fundamental Frequency
- *: Out of Restricted Band
- The emission levels of other frequencies were very low against the limit

EUT Test Condition		Measurement Detail	
Channel	Channel 110	Frequency Range	1 GHz ~ 40 GHz
Input Power	120 Vac, 60 Hz	Detector Function	Peak (PK) Average (AV)
Environmental Conditions	25 deg. C, 65 % RH	Tested By	Karl Lee

Antenna Polarity & Test Distance: Horizontal at 3 m										
Frequency (MHz)	Emission Level (dBuV/m)	Read Level (dBuV)	Limit (dBuV/m)	Margin (dB)	Antenna Factor (dB/m)	Cable Loss (dB)	Preamp Factor (dB)	Antenna Height (cm)	Table Angle (Degree)	Remark
5460.08	43.93	35.11	54	-10.07	34.36	8.51	34.05	103	150	Average
5460.08	53.93	45.11	74	-20.07	34.36	8.51	34.05	103	150	Peak
*5470.64	53.05	44.22	68.2	-15.15	34.37	8.51	34.05	103	150	Peak
5550	94.91	85.94			34.45	8.59	34.07	103	150	Average
5550	101.83	92.86			34.45	8.59	34.07	103	150	Peak
*5725.48	53.56	44.4	68.2	-14.64	34.62	8.65	34.11	103	150	Peak
11100	48.41	33.32	54	-5.59	37.66	12.89	35.46	122	162	Average
11100	57.01	41.92	74	-16.99	37.66	12.89	35.46	122	162	Peak
Antenna Polarity & Test Distance: Vertical at 3 m										
Frequency (MHz)	Emission Level (dBuV/m)	Read Level (dBuV)	Limit (dBuV/m)	Margin (dB)	Antenna Factor (dB/m)	Cable Loss (dB)	Preamp Factor (dB)	Antenna Height (cm)	Table Angle (Degree)	Remark
5453.2	43.29	34.47	54	-10.71	34.36	8.51	34.05	251	269	Average
5453.2	53.97	45.15	74	-20.03	34.36	8.51	34.05	251	269	Peak
*5468.24	53.22	44.39	68.2	-14.98	34.37	8.51	34.05	251	269	Peak
5550	89.56	80.59			34.45	8.59	34.07	251	269	Average
5550	96.69	87.72			34.45	8.59	34.07	251	269	Peak
*5725.64	53.45	44.29	68.2	-14.75	34.62	8.65	34.11	251	269	Peak
11100	45.61	30.52	54	-8.39	37.66	12.89	35.46	166	163	Average
11100	55.99	40.9	74	-18.01	37.66	12.89	35.46	166	163	Peak

Remarks:

- Emission Level = Read Level + Antenna Factor + Cable Loss - Preamp Factor
Margin value = Emission level – Limit value
- 5550 MHz: Fundamental Frequency
- *: Out of Restricted Band
- The emission levels of other frequencies were very low against the limit

EUT Test Condition		Measurement Detail	
Channel	Channel 134	Frequency Range	1 GHz ~ 40 GHz
Input Power	120 Vac, 60 Hz	Detector Function	Peak (PK) Average (AV)
Environmental Conditions	25 deg. C, 65 % RH	Tested By	Karl Lee

Antenna Polarity & Test Distance: Horizontal at 3 m										
Frequency (MHz)	Emission Level (dBuV/m)	Read Level (dBuV)	Limit (dBuV/m)	Margin (dB)	Antenna Factor (dB/m)	Cable Loss (dB)	Preamp Factor (dB)	Antenna Height (cm)	Table Angle (Degree)	Remark
5448.08	42.62	33.79	54	-11.38	34.36	8.51	34.04	106	183	Average
5448.08	53.21	44.38	74	-20.79	34.36	8.51	34.04	106	183	Peak
*5469.68	52.15	43.32	68.2	-16.05	34.37	8.51	34.05	106	183	Peak
5670	89.96	80.86			34.57	8.63	34.1	106	183	Average
5670	97.61	88.51			34.57	8.63	34.1	106	183	Peak
*5725.72	54.53	45.37	68.2	-13.67	34.62	8.65	34.11	106	183	Peak
11340	47.66	32.57	54	-6.34	37.8	12.71	35.42	122	165	Average
11340	57.67	42.58	74	-16.33	37.8	12.71	35.42	122	165	Peak

Antenna Polarity & Test Distance: Vertical at 3 m										
Frequency (MHz)	Emission Level (dBuV/m)	Read Level (dBuV)	Limit (dBuV/m)	Margin (dB)	Antenna Factor (dB/m)	Cable Loss (dB)	Preamp Factor (dB)	Antenna Height (cm)	Table Angle (Degree)	Remark
5452.72	42.55	33.73	54	-11.45	34.36	8.51	34.05	236	246	Average
5452.72	53.1	44.28	74	-20.9	34.36	8.51	34.05	236	246	Peak
*5470.64	52.58	43.75	68.2	-15.62	34.37	8.51	34.05	236	246	Peak
5670	84.88	75.78			34.57	8.63	34.1	236	246	Average
5670	92.94	83.84			34.57	8.63	34.1	236	246	Peak
*5725.8	52.78	43.62	68.2	-15.42	34.62	8.65	34.11	236	246	Peak
11340	47.74	32.65	54	-6.26	37.8	12.71	35.42	100	155	Average
11340	57.38	42.29	74	-16.62	37.8	12.71	35.42	100	155	Peak

Remarks:

- Emission Level = Read Level + Antenna Factor + Cable Loss - Preamp Factor
Margin value = Emission level – Limit value
- 5670 MHz: Fundamental Frequency
- *: Out of Restricted Band
- The emission levels of other frequencies were very low against the limit

EUT Test Condition		Measurement Detail	
Channel	Channel 151	Frequency Range	1 GHz ~ 40 GHz
Input Power	120 Vac, 60 Hz	Detector Function	Peak (PK) Average (AV)
Environmental Conditions	25 deg. C, 65 % RH	Tested By	Karl Lee

<Spurious Emission>

Antenna Polarity & Test Distance: Horizontal at 3 m										
Frequency (MHz)	Emission Level (dBuV/m)	Read Level (dBuV)	Limit (dBuV/m)	Margin (dB)	Antenna Factor (dB/m)	Cable Loss (dB)	Preamp Factor (dB)	Antenna Height (cm)	Table Angle (Degree)	Remark
5755	90.63	81.42			34.66	8.66	34.11	122	184	Average
5755	98.21	89			34.66	8.66	34.11	122	184	Peak
11510	47.47	32.36	54	-6.53	37.9	12.6	35.39	140	140	Average
11510	55.42	40.31	74	-18.58	37.9	12.6	35.39	140	140	Peak
Antenna Polarity & Test Distance: Vertical at 3 m										
Frequency (MHz)	Emission Level (dBuV/m)	Read Level (dBuV)	Limit (dBuV/m)	Margin (dB)	Antenna Factor (dB/m)	Cable Loss (dB)	Preamp Factor (dB)	Antenna Height (cm)	Table Angle (Degree)	Remark
5755	85.54	76.33			34.66	8.66	34.11	220	276	Average
5755	92.88	83.67			34.66	8.66	34.11	220	276	Peak
11510	47.54	32.43	54	-6.46	37.9	12.6	35.39	134	265	Average
11510	56.23	41.12	74	-17.77	37.9	12.6	35.39	134	265	Peak

<Out of Band Emission (OOBE)>

Antenna Polarity & Test Distance: Horizontal at 3 m										
Frequency (MHz)	Emission Level (dBuV/m)	Read Level (dBuV)	Limit (dBuV/m)	Margin (dB)	Antenna Factor (dB/m)	Cable Loss (dB)	Preamp Factor (dB)	Antenna Height (cm)	Table Angle (Degree)	Remark
*5614.975	53.17	44.14	68.2	-15.03	34.5	8.61	34.08	122	184	Peak
5653.825	53.25	44.16	71.03	-17.78	34.56	8.63	34.1	122	184	Peak
5923.675	53.41	44.01	69.18	-15.77	34.83	8.73	34.16	122	184	Peak
*5965.675	53.35	43.9	68.2	-14.85	34.87	8.75	34.17	122	184	Peak
Antenna Polarity & Test Distance: Vertical at 3 m										
Frequency (MHz)	Emission Level (dBuV/m)	Read Level (dBuV)	Limit (dBuV/m)	Margin (dB)	Antenna Factor (dB/m)	Cable Loss (dB)	Preamp Factor (dB)	Antenna Height (cm)	Table Angle (Degree)	Remark
*5517.325	53.35	44.42	68.2	-14.85	34.42	8.57	34.06	220	276	Peak
5652.25	52.2	43.11	69.86	-17.66	34.56	8.62	34.09	220	276	Peak
5923.675	52.74	43.34	69.18	-16.44	34.83	8.73	34.16	220	276	Peak
*5954.65	53.61	44.18	68.2	-14.59	34.85	8.74	34.16	220	276	Peak

Remarks:

- Emission Level = Read Level + Antenna Factor + Cable Loss - Preamp Factor
Margin value = Emission level – Limit value
- 5755 MHz: Fundamental Frequency
- *: Out of Restricted Band
- The emission levels of other frequencies were very low against the limit

EUT Test Condition		Measurement Detail	
Channel	Channel 159	Frequency Range	1 GHz ~ 40 GHz
Input Power	120 Vac, 60 Hz	Detector Function	Peak (PK) Average (AV)
Environmental Conditions	25 deg. C, 65 % RH	Tested By	Karl Lee

<Spurious Emission>

Antenna Polarity & Test Distance: Horizontal at 3 m										
Frequency (MHz)	Emission Level (dBuV/m)	Read Level (dBuV)	Limit (dBuV/m)	Margin (dB)	Antenna Factor (dB/m)	Cable Loss (dB)	Preamp Factor (dB)	Antenna Height (cm)	Table Angle (Degree)	Remark
5795	93.04	83.8			34.69	8.68	34.13	121	184	Average
5795	101.69	92.45			34.69	8.68	34.13	121	184	Peak
11590	47.87	32.5	54	-6.13	38.02	12.72	35.37	134	222	Average
11590	56.4	41.03	74	-17.6	38.02	12.72	35.37	134	222	Peak
Antenna Polarity & Test Distance: Vertical at 3 m										
Frequency (MHz)	Emission Level (dBuV/m)	Read Level (dBuV)	Limit (dBuV/m)	Margin (dB)	Antenna Factor (dB/m)	Cable Loss (dB)	Preamp Factor (dB)	Antenna Height (cm)	Table Angle (Degree)	Remark
5795	88.93	79.69			34.69	8.68	34.13	220	276	Average
5795	96.12	86.88			34.69	8.68	34.13	220	276	Peak
11590	47.89	32.52	54	-6.11	38.02	12.72	35.37	124	44	Average
11590	55.7	40.33	74	-18.3	38.02	12.72	35.37	124	44	Peak

<Out of Band Emission (OOBE)>

Antenna Polarity & Test Distance: Horizontal at 3 m										
Frequency (MHz)	Emission Level (dBuV/m)	Read Level (dBuV)	Limit (dBuV/m)	Margin (dB)	Antenna Factor (dB/m)	Cable Loss (dB)	Preamp Factor (dB)	Antenna Height (cm)	Table Angle (Degree)	Remark
*5612.875	53.96	44.93	68.2	-14.24	34.5	8.61	34.08	121	184	Peak
5652.775	51.75	42.65	70.25	-18.5	34.56	8.63	34.09	121	184	Peak
5921.575	52.37	42.97	70.73	-18.36	34.83	8.73	34.16	121	184	Peak
*5932.6	53.88	44.48	68.2	-14.32	34.83	8.73	34.16	121	184	Peak
Antenna Polarity & Test Distance: Vertical at 3 m										
Frequency (MHz)	Emission Level (dBuV/m)	Read Level (dBuV)	Limit (dBuV/m)	Margin (dB)	Antenna Factor (dB/m)	Cable Loss (dB)	Preamp Factor (dB)	Antenna Height (cm)	Table Angle (Degree)	Remark
*5609.725	53.29	44.26	68.2	-14.91	34.5	8.61	34.08	220	276	Peak
5652.775	51.24	42.14	70.25	-19.01	34.56	8.63	34.09	220	276	Peak
5922.625	52.06	42.66	69.96	-17.9	34.83	8.73	34.16	220	276	Peak
*5949.4	53.1	43.67	68.2	-15.1	34.85	8.74	34.16	220	276	Peak

Remarks:

- Emission Level = Read Level + Antenna Factor + Cable Loss - Preamp Factor
Margin value = Emission level – Limit value
- 5795 MHz: Fundamental Frequency
- *: Out of Restricted Band
- The emission levels of other frequencies were very low against the limit

802.11ac (VHT80)

EUT Test Condition		Measurement Detail	
Channel	Channel 42	Frequency Range	1 GHz ~ 40 GHz
Input Power	120 Vac, 60 Hz	Detector Function	Peak (PK) Average (AV)
Environmental Conditions	25 deg. C, 65 % RH	Tested By	Charles Hsiao

Antenna Polarity & Test Distance: Horizontal at 3 m

Frequency (MHz)	Emission Level (dBuV/m)	Read Level (dBuV)	Limit (dBuV/m)	Margin (dB)	Antenna Factor (dB/m)	Cable Loss (dB)	Preamp Factor (dB)	Antenna Height (cm)	Table Angle (Degree)	Remark
5146.4	45.39	37.14	54	-8.61	34.12	8.13	34	100	170	Average
5146.4	55.72	47.47	74	-18.28	34.12	8.13	34	100	170	Peak
5210	90.54	82.18			34.17	8.19	34	100	170	Average
5210	97	88.64			34.17	8.19	34	100	170	Peak
5457.14	43.35	34.53	54	-10.65	34.36	8.51	34.05	100	170	Average
5457.14	53.22	44.4	74	-20.78	34.36	8.51	34.05	100	170	Peak
*10420	55.54	41.13	68.2	-12.66	37.15	12.42	35.16	180	199	Peak

Antenna Polarity & Test Distance: Vertical at 3 m

Frequency (MHz)	Emission Level (dBuV/m)	Read Level (dBuV)	Limit (dBuV/m)	Margin (dB)	Antenna Factor (dB/m)	Cable Loss (dB)	Preamp Factor (dB)	Antenna Height (cm)	Table Angle (Degree)	Remark
5142.95	43.58	35.32	54	-10.42	34.12	8.13	33.99	100	213	Average
5142.95	53.41	45.15	74	-20.59	34.12	8.13	33.99	100	213	Peak
5210	86.55	78.19			34.17	8.19	34	100	213	Average
5210	93.74	85.38			34.17	8.19	34	100	213	Peak
5353.52	43.04	34.41	54	-10.96	34.28	8.38	34.03	100	213	Average
5353.52	52.83	44.2	74	-21.17	34.28	8.38	34.03	100	213	Peak
*10420	54.94	40.53	68.2	-13.26	37.15	12.42	35.16	115	246	Peak

Remarks:

- Emission Level = Read Level + Antenna Factor + Cable Loss - Preamp Factor
Margin value = Emission level – Limit value
- 5210 MHz: Fundamental Frequency
- *: Out of Restricted Band
- The emission levels of other frequencies were very low against the limit

EUT Test Condition		Measurement Detail	
Channel	Channel 58	Frequency Range	1 GHz ~ 40 GHz
Input Power	120 Vac, 60 Hz	Detector Function	Peak (PK) Average (AV)
Environmental Conditions	25 deg. C, 65 % RH	Tested By	Charles Hsiao

Antenna Polarity & Test Distance: Horizontal at 3 m										
Frequency (MHz)	Emission Level (dBuV/m)	Read Level (dBuV)	Limit (dBuV/m)	Margin (dB)	Antenna Factor (dB/m)	Cable Loss (dB)	Preamp Factor (dB)	Antenna Height (cm)	Table Angle (Degree)	Remark
5143.7	43.02	34.76	54	-10.98	34.12	8.13	33.99	123	182	Average
5143.7	53.1	44.84	74	-20.9	34.12	8.13	33.99	123	182	Peak
5290	92.55	84.02			34.23	8.32	34.02	123	182	Average
5290	99.64	91.11			34.23	8.32	34.02	123	182	Peak
5351.65	47.33	38.7	54	-6.67	34.28	8.38	34.03	123	182	Average
5351.65	65.39	56.76	74	-8.61	34.28	8.38	34.03	123	182	Peak
*10580	55.47	40.82	68.2	-12.73	37.27	12.65	35.27	183	111	Peak
Antenna Polarity & Test Distance: Vertical at 3 m										
Frequency (MHz)	Emission Level (dBuV/m)	Read Level (dBuV)	Limit (dBuV/m)	Margin (dB)	Antenna Factor (dB/m)	Cable Loss (dB)	Preamp Factor (dB)	Antenna Height (cm)	Table Angle (Degree)	Remark
5043.05	42.88	34.82	54	-11.12	34.04	8	33.98	100	194	Average
5043.05	53.65	45.59	74	-20.35	34.04	8	33.98	100	194	Peak
5290	88.59	80.06			34.23	8.32	34.02	100	194	Average
5290	95.34	86.81			34.23	8.32	34.02	100	194	Peak
5353.85	45.45	36.82	54	-8.55	34.28	8.38	34.03	100	194	Average
5353.85	62.11	53.48	74	-11.89	34.28	8.38	34.03	100	194	Peak
*10580	56.23	41.58	68.2	-11.97	37.27	12.65	35.27	135	55	Peak

Remarks:

- Emission Level = Read Level + Antenna Factor + Cable Loss - Preamp Factor
Margin value = Emission level – Limit value
- 5290 MHz: Fundamental Frequency
- *: Out of Restricted Band
- The emission levels of other frequencies were very low against the limit

EUT Test Condition		Measurement Detail	
Channel	Channel 106	Frequency Range	1 GHz ~ 40 GHz
Input Power	120 Vac, 60 Hz	Detector Function	Peak (PK) Average (AV)
Environmental Conditions	25 deg. C, 65 % RH	Tested By	Karl Lee

Antenna Polarity & Test Distance: Horizontal at 3 m										
Frequency (MHz)	Emission Level (dBuV/m)	Read Level (dBuV)	Limit (dBuV/m)	Margin (dB)	Antenna Factor (dB/m)	Cable Loss (dB)	Preamp Factor (dB)	Antenna Height (cm)	Table Angle (Degree)	Remark
5459.44	50.77	41.95	54	-3.23	34.36	8.51	34.05	111	150	Average
5459.44	60.37	51.55	74	-13.63	34.36	8.51	34.05	111	150	Peak
*5470.8	61.53	52.67	68.2	-6.67	34.37	8.54	34.05	111	150	Peak
5530	91.68	82.75			34.42	8.58	34.07	111	150	Average
5530	98.81	89.88			34.42	8.58	34.07	111	150	Peak
*5725.24	52.87	43.71	68.2	-15.33	34.62	8.65	34.11	111	150	Peak
11060	48.23	33.15	54	-5.77	37.64	12.91	35.47	182	117	Average
11060	57.69	42.61	74	-16.31	37.64	12.91	35.47	182	117	Peak

Antenna Polarity & Test Distance: Vertical at 3 m										
Frequency (MHz)	Emission Level (dBuV/m)	Read Level (dBuV)	Limit (dBuV/m)	Margin (dB)	Antenna Factor (dB/m)	Cable Loss (dB)	Preamp Factor (dB)	Antenna Height (cm)	Table Angle (Degree)	Remark
5459.92	46.97	38.15	54	-7.03	34.36	8.51	34.05	251	269	Average
5459.92	56.52	47.7	74	-17.48	34.36	8.51	34.05	251	269	Peak
*5469.84	55.23	46.4	68.2	-12.97	34.37	8.51	34.05	251	269	Peak
5530	86.06	77.13			34.42	8.58	34.07	251	269	Average
5530	93.48	84.55			34.42	8.58	34.07	251	269	Peak
*5724.68	51.93	42.77	68.2	-16.27	34.62	8.65	34.11	251	269	Peak
11060	47.42	32.34	54	-6.58	37.64	12.91	35.47	125	186	Average
11060	57.1	42.02	74	-16.9	37.64	12.91	35.47	125	186	Peak

Remarks:

- Emission Level = Read Level + Antenna Factor + Cable Loss - Preamp Factor
Margin value = Emission level – Limit value
- 5530 MHz: Fundamental Frequency
- *: Out of Restricted Band
- The emission levels of other frequencies were very low against the limit

EUT Test Condition		Measurement Detail	
Channel	Channel 122	Frequency Range	1 GHz ~ 40 GHz
Input Power	120 Vac, 60 Hz	Detector Function	Peak (PK) Average (AV)
Environmental Conditions	25 deg. C, 65 % RH	Tested By	Karl Lee

Antenna Polarity & Test Distance: Horizontal at 3 m										
Frequency (MHz)	Emission Level (dBuV/m)	Read Level (dBuV)	Limit (dBuV/m)	Margin (dB)	Antenna Factor (dB/m)	Cable Loss (dB)	Preamp Factor (dB)	Antenna Height (cm)	Table Angle (Degree)	Remark
5457.2	43.3	34.48	54	-10.7	34.36	8.51	34.05	103	150	Average
5457.2	53.54	44.72	74	-20.46	34.36	8.51	34.05	103	150	Peak
*5470	52.28	43.45	68.2	-15.92	34.37	8.51	34.05	103	150	Peak
5610	90.43	81.4			34.5	8.61	34.08	103	150	Average
5610	98.5	89.47			34.5	8.61	34.08	103	150	Peak
*5723.96	52.97	43.81	68.2	-15.23	34.62	8.65	34.11	103	150	Peak
11220	48.16	33.07	54	-5.84	37.73	12.8	35.44	159	63	Average
11220	57.72	42.63	74	-16.28	37.73	12.8	35.44	159	63	Peak

Antenna Polarity & Test Distance: Vertical at 3 m										
Frequency (MHz)	Emission Level (dBuV/m)	Read Level (dBuV)	Limit (dBuV/m)	Margin (dB)	Antenna Factor (dB/m)	Cable Loss (dB)	Preamp Factor (dB)	Antenna Height (cm)	Table Angle (Degree)	Remark
5456.88	43.23	34.41	54	-10.77	34.36	8.51	34.05	251	269	Average
5456.88	53.75	44.93	74	-20.25	34.36	8.51	34.05	251	269	Peak
*5468.88	52.42	43.59	68.2	-15.78	34.37	8.51	34.05	251	269	Peak
5610	86.32	77.29			34.5	8.61	34.08	251	269	Average
5610	93.78	84.75			34.5	8.61	34.08	251	269	Peak
*5724.68	52.6	43.44	68.2	-15.6	34.62	8.65	34.11	251	269	Peak
11220	48.15	33.06	54	-5.85	37.73	12.8	35.44	163	190	Average
11220	57.8	42.71	74	-16.2	37.73	12.8	35.44	163	190	Peak

Remarks:

- Emission Level = Read Level + Antenna Factor + Cable Loss - Preamp Factor
Margin value = Emission level – Limit value
- 5610 MHz: Fundamental Frequency
- *: Out of Restricted Band
- The emission levels of other frequencies were very low against the limit

EUT Test Condition		Measurement Detail	
Channel	Channel 155	Frequency Range	1 GHz ~ 40 GHz
Input Power	120 Vac, 60 Hz	Detector Function	Peak (PK) Average (AV)
Environmental Conditions	25 deg. C, 65 % RH	Tested By	Karl Lee

<Spurious Emission>

Antenna Polarity & Test Distance: Horizontal at 3 m										
Frequency (MHz)	Emission Level (dBuV/m)	Read Level (dBuV)	Limit (dBuV/m)	Margin (dB)	Antenna Factor (dB/m)	Cable Loss (dB)	Preamp Factor (dB)	Antenna Height (cm)	Table Angle (Degree)	Remark
5775	87.88	78.65			34.68	8.67	34.12	121	184	Average
5775	95.06	85.83			34.68	8.67	34.12	121	184	Peak
11550	48.27	33	54	-5.73	37.97	12.68	35.38	154	4	Average
11550	56.57	41.3	74	-17.43	37.97	12.68	35.38	154	4	Peak
Antenna Polarity & Test Distance: Vertical at 3 m										
Frequency (MHz)	Emission Level (dBuV/m)	Read Level (dBuV)	Limit (dBuV/m)	Margin (dB)	Antenna Factor (dB/m)	Cable Loss (dB)	Preamp Factor (dB)	Antenna Height (cm)	Table Angle (Degree)	Remark
5775	82.47	73.24			34.68	8.67	34.12	220	276	Average
5775	90.05	80.82			34.68	8.67	34.12	220	276	Peak
11550	47.86	32.59	54	-6.14	37.97	12.68	35.38	131	126	Average
11550	56.89	41.62	74	-17.11	37.97	12.68	35.38	131	126	Peak

<Out of Band Emission (OOBE)>

Antenna Polarity & Test Distance: Horizontal at 3 m										
Frequency (MHz)	Emission Level (dBuV/m)	Read Level (dBuV)	Limit (dBuV/m)	Margin (dB)	Antenna Factor (dB/m)	Cable Loss (dB)	Preamp Factor (dB)	Antenna Height (cm)	Table Angle (Degree)	Remark
*5527.3	53.64	44.71	68.2	-14.56	34.42	8.58	34.07	121	184	Peak
5652.25	52.24	43.15	69.86	-17.62	34.56	8.62	34.09	121	184	Peak
5922.625	51.49	42.09	69.96	-18.47	34.83	8.73	34.16	121	184	Peak
*6000.325	54.23	44.74	68.2	-13.97	34.9	8.76	34.17	121	184	Peak
Antenna Polarity & Test Distance: Vertical at 3 m										
Frequency (MHz)	Emission Level (dBuV/m)	Read Level (dBuV)	Limit (dBuV/m)	Margin (dB)	Antenna Factor (dB/m)	Cable Loss (dB)	Preamp Factor (dB)	Antenna Height (cm)	Table Angle (Degree)	Remark
*5593.45	52.99	43.98	68.2	-15.21	34.49	8.6	34.08	220	276	Peak
5652.775	51.63	42.53	70.25	-18.62	34.56	8.63	34.09	220	276	Peak
5923.675	52.09	42.69	69.18	-17.09	34.83	8.73	34.16	220	276	Peak
*6011.875	53.41	43.91	68.2	-14.79	34.92	8.76	34.18	220	276	Peak

Remarks:

- Emission Level = Read Level + Antenna Factor + Cable Loss - Preamp Factor
Margin value = Emission level – Limit value
- 5775 MHz: Fundamental Frequency
- *: Out of Restricted Band
- The emission levels of other frequencies were very low against the limit

9 kHz ~ 30 MHz Data:

The amplitude of spurious emissions attenuated more than 20 dB below the permissible value is not required to be report.

30 MHz ~ 1 GHz Worst-Case Data:

802.11ac (VHT80)

EUT Test Condition		Measurement Detail	
Channel	Channel 106	Frequency Range	30 MHz ~ 1 GHz
Input Power	120 Vac, 60 Hz	Detector Function	Peak (PK) Quasi-peak (QP)
Environmental Conditions	25 deg. C, 65 % RH	Tested By	Harry Hsueh

Horizontal

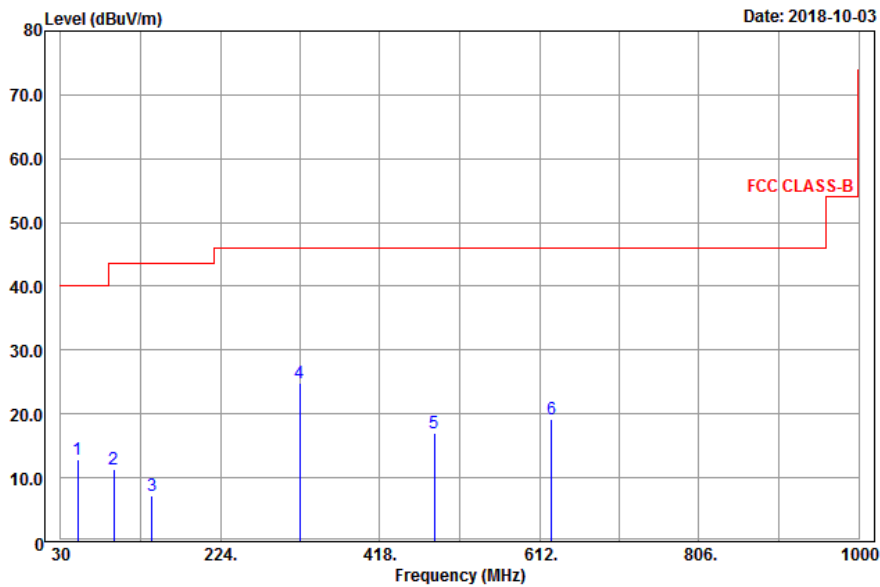

Vertical

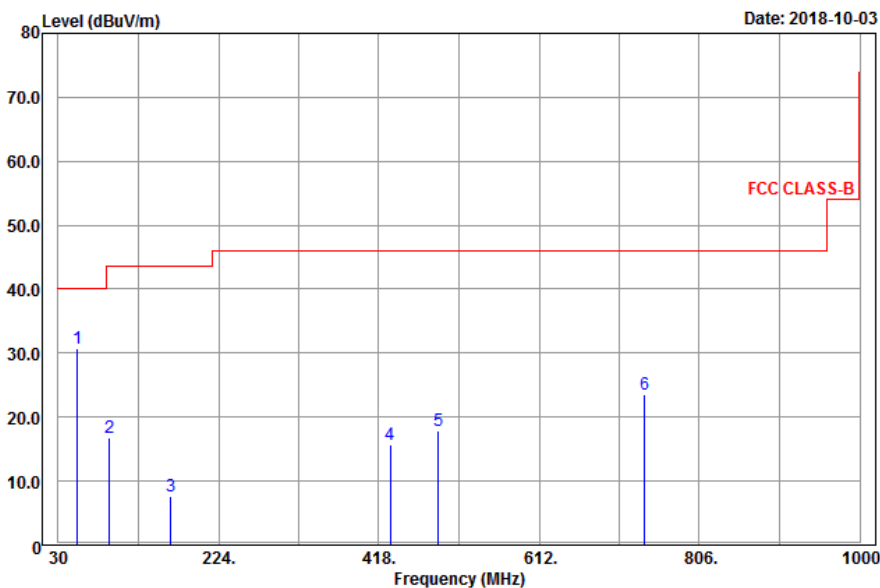

Antenna Polarity & Test Distance: Horizontal at 3 m

Frequency (MHz)	Emission Level (dBuV/m)	Read Level (dBuV)	Limit (dBuV/m)	Margin (dB)	Antenna Factor (dB/m)	Cable Loss (dB)	Preamp Factor (dB)	Antenna Height (cm)	Table Angle (Degree)	Remark
50.52	12.75	29.53	40	-27.25	14.54	0.9	32.22	102	132	Peak
94.53	11.35	30.61	43.5	-32.15	11.62	1.11	31.99	155	195	Peak
140.7	7.12	29.59	43.5	-36.38	8.42	1.38	32.27	187	195	Peak
321	24.82	41.28	46	-21.18	13.54	2.11	32.11	111	101	Peak
484.1	17	30.42	46	-29	16.13	2.56	32.11	142	163	Peak
626.9	19.15	30.21	46	-26.85	18.18	2.93	32.17	108	175	Peak

Antenna Polarity & Test Distance: Vertical at 3 m

Frequency (MHz)	Emission Level (dBuV/m)	Read Level (dBuV)	Limit (dBuV/m)	Margin (dB)	Antenna Factor (dB/m)	Cable Loss (dB)	Preamp Factor (dB)	Antenna Height (cm)	Table Angle (Degree)	Remark
53.22	30.63	47.66	40	-9.37	14.3	0.9	32.23	162	135	Peak
92.37	16.88	36.67	43.5	-26.62	10.92	1.11	31.82	199	156	Peak
165.81	7.58	29.36	43.5	-35.92	8.95	1.52	32.25	102	132	Peak
431.6	15.67	30.09	46	-30.33	15.34	2.41	32.17	166	157	Peak
490.4	17.79	31.05	46	-28.21	16.22	2.63	32.11	111	145	Peak
739.6	23.61	32.87	46	-22.39	19.71	3.16	32.13	102	195	Peak

Remarks:

- Emission Level = Read Level + Antenna Factor + Cable Loss - Preamp Factor
Margin value = Emission level – Limit value
- The emission levels of other frequencies were very low against the limit

4.2 Conducted Emission Measurement

4.2.1 Limits of Conducted Emission Measurement

Frequency (MHz)	Conducted Limit (dBUV)	
	Quasi-Peak	Average
0.15 - 0.5	66 - 56	56 - 46
0.50 - 5.0	56	46
5.0 - 30.0	60	50

- Note: 1. The lower limit shall apply at the transition frequencies.
 2. The limit decreases in line with the logarithm of the frequency in the range of 0.15 to 0.50 MHz.

4.2.2 Test Instruments

Description & Manufacturer	Model No.	Serial No.	Date of Calibration	Due Date of Calibration
Test Receiver ROHDE & SCHWARZ	ESCI	100613	Nov. 23, 2017	Nov. 22, 2018
RF signal cable Woken	5D-FB	Cable-cond1-01	Sep. 05, 2018	Sep. 04, 2019
LISN/AMN ROHDE & SCHWARZ (EUT)	ENV216	101826	Feb. 26, 2018	Feb. 25, 2019
LISN/AMN ROHDE & SCHWARZ (Peripheral)	ESH3-Z5	100311	Aug. 19, 2018	Aug. 18, 2019
Software ADT	BV ADT_Cond_ V7.3.7.4	NA	NA	NA

- Note: 1. The calibration interval of the above test instruments is 12 months and the calibrations are traceable to NML/ROC and NIST/USA.
 2. The test was performed in HwaYa Shielded Room 1.
 3. The VCCI Site Registration No. is C-2040.

4.2.3 Test Procedures

- a. The EUT was placed 0.4 meters from the conducting wall of the shielded room with EUT being connected to the power mains through a line impedance stabilization network (LISN). Other support units were connected to the power mains through another LISN. The two LISNs provide 50 ohm/ 50uH of coupling impedance for the measuring instrument.
- b. Both lines of the power mains connected to the EUT were checked for maximum conducted interference.
- c. The frequency range from 150 kHz to 30 MHz was searched. Emission levels under (Limit -20 dB) was not recorded.

Note: All modes of operation were investigated and the worst-case emissions are reported.

4.2.4 Deviation from Test Standard

No deviation.

4.2.5 Test Setup

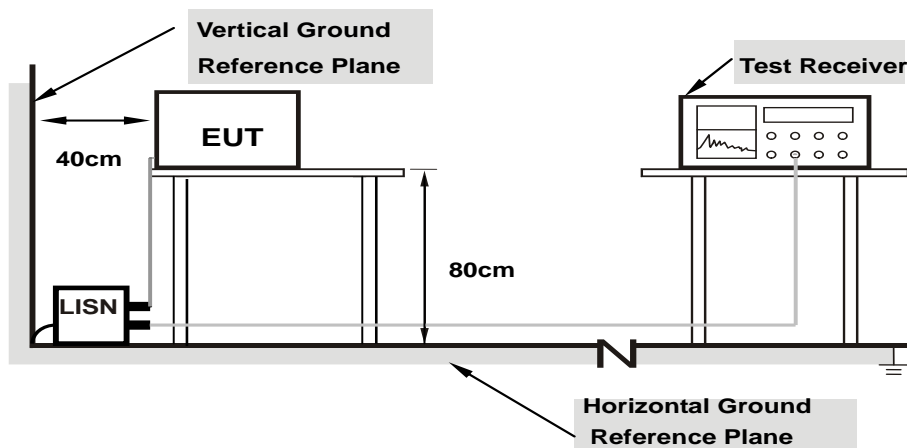

- Note:**
- 1.Support units were connected to second LISN.
 - 2.Both of LISNs (AMN) are 80 cm from EUT and at least 80 from other units and other metal planes

For the actual test configuration, please refer to the attached file (Test Setup Photo).

4.2.6 EUT Operating Conditions

- a. Placed the EUT on a testing table.
- b. Use the software to control the EUT under transmission condition continuously at specific channel frequency.

4.2.7 Test Results

Frequency Range	150kHz ~ 30MHz	Detector Function & Resolution Bandwidth	Quasi-Peak (QP) / Average (AV), 9kHz
Input Power	120Vac, 60Hz	Environmental Conditions	25°C, 65%RH
Tested by	Jisyong Wang	Test Date	2018/9/28

Phase Of Power : Line (L)										
No	Frequency (MHz)	Correction Factor (dB)	Reading Value (dBuV)		Emission Level (dBuV)		Limit (dBuV)		Margin (dB)	
			Q.P.	AV.	Q.P.	AV.	Q.P.	AV.	Q.P.	AV.
1	0.15782	9.67	34.51	20.55	44.18	30.22	65.58	55.58	-21.40	-25.36
2	0.20031	9.67	27.12	13.55	36.79	23.22	63.60	53.60	-26.81	-30.38
3	0.23211	9.67	28.07	14.41	37.74	24.08	62.37	52.37	-24.63	-28.29
4	0.61920	9.66	31.14	15.86	40.80	25.52	56.00	46.00	-15.20	-20.48
5	5.63182	9.76	27.20	13.07	36.96	22.83	60.00	50.00	-23.04	-27.17
6	15.04710	9.89	34.66	18.18	44.55	28.07	60.00	50.00	-15.45	-21.93

Remarks:

1. Q.P. and AV. are abbreviations of quasi-peak and average individually.
2. The emission levels of other frequencies were very low against the limit.
3. Margin value = Emission level – Limit value
4. Correction factor = Insertion loss + Cable loss
5. Emission Level = Correction Factor + Reading Value

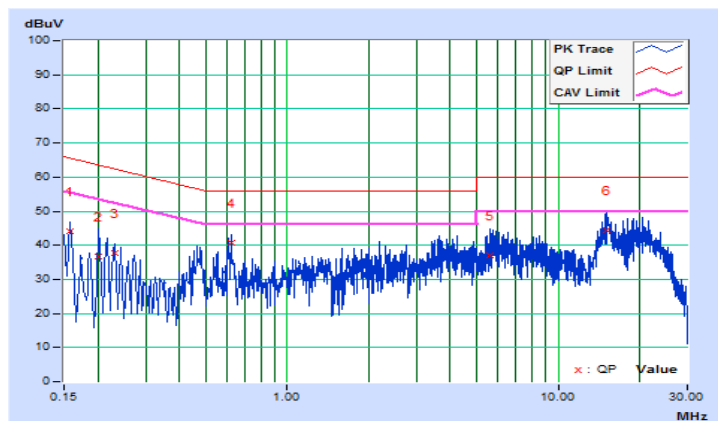

Frequency Range	150kHz ~ 30MHz	Detector Function & Resolution Bandwidth	Quasi-Peak (QP) / Average (AV), 9kHz
Input Power	120Vac, 60Hz	Environmental Conditions	25°C, 65%RH
Tested by	Jisyong Wang	Test Date	2018/9/28

Phase Of Power : Neutral (N)										
No	Frequency (MHz)	Correction Factor (dB)	Reading Value (dBuV)		Emission Level (dBuV)		Limit (dBuV)		Margin (dB)	
			Q.P.	AV.	Q.P.	AV.	Q.P.	AV.	Q.P.	AV.
1	0.15760	9.68	31.46	14.40	41.14	24.08	65.59	55.59	-24.45	-31.51
2	0.22434	9.67	27.96	11.84	37.63	21.51	62.66	52.66	-25.03	-31.15
3	0.49408	9.67	23.87	9.23	33.54	18.90	56.10	46.10	-22.56	-27.20
4	0.55273	9.66	24.99	12.08	34.65	21.74	56.00	46.00	-21.35	-24.26
5	0.62311	9.66	23.14	5.96	32.80	15.62	56.00	46.00	-23.20	-30.38
6	18.01479	9.98	33.49	20.23	43.47	30.21	60.00	50.00	-16.53	-19.79

Remarks:

1. Q.P. and AV. are abbreviations of quasi-peak and average individually.
2. The emission levels of other frequencies were very low against the limit.
3. Margin value = Emission level – Limit value
4. Correction factor = Insertion loss + Cable loss
5. Emission Level = Correction Factor + Reading Value

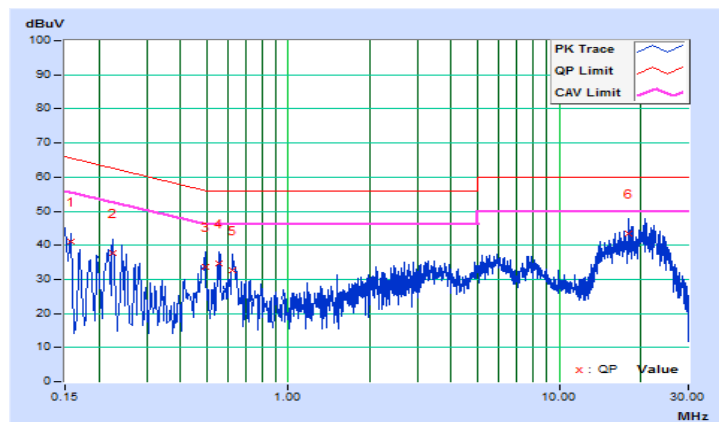

4.3 Transmit Power Measurement

4.3.1 Limits of Transmit Power Measurement

Operation Band	EUT Category	Limit
U-NII-1	Outdoor Access Point	1 Watt (30 dBm) (Max. e.i.r.p \leq 125 mW (21 dBm) at any elevation angle above 30 degrees as measured from the horizon)
	Fixed point-to-point Access Point	1 Watt (30 dBm)
	Indoor Access Point	1 Watt (30 dBm)
	√ Mobile and Portable client device	250 mW (24 dBm)
U-NII-2A	√	250 mW (24 dBm) or 11 dBm + 10 log B*
U-NII-2C	√	250 mW (24 dBm) or 11 dBm + 10 log B*
U-NII-3	√	1 Watt (30 dBm)

*B is the 26 dB emission bandwidth in megahertz

4.3.2 Test Setup

<Power Output Measurement>

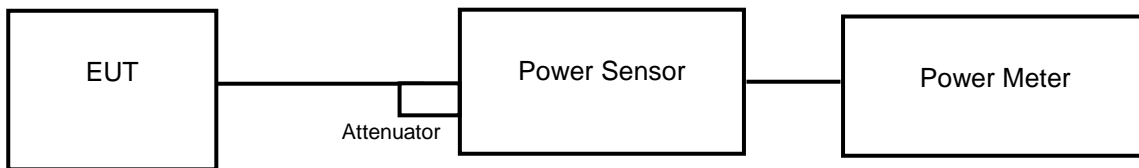

or

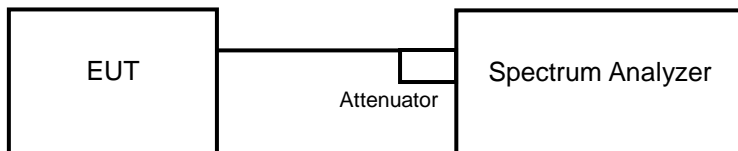

<26 dB Bandwidth>

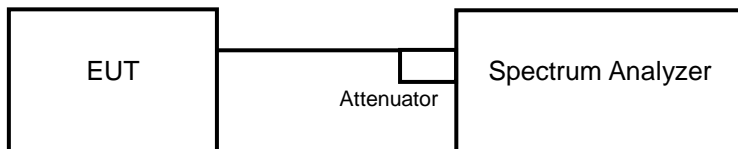

4.3.3 Test Instruments

Refer to section 4.1.2 to get information of above instrument.

4.3.4 Test Procedure

Average Power Measurement

<802.11a, 802.11n (HT20), 802.11n (HT40)>

Method PM is used to perform output power measurement, trigger and gating function of wide band power meter is enabled to measure max output power of TX on burst. Duty factor is not added to measured value.

<802.11ac (VHT80)>

- a. Set span to encompass the entire 26 dB EBW (or, alternatively, the entire 99 % occupied bandwidth) of the signal.
- b. Set sweep trigger to "free run".
- c. Set RBW = 1 MHz.
- d. Set VBW \geq 3 MHz
- e. Number of points in sweep \geq 2 Span / RBW.
- f. Sweep time \leq (number of points in sweep) * T
- g. Using emission bandwidth to determine the frequency span for integration the channel bandwidth.
- h. Detector = RMS.
- i. Trace mode = max hold.
- j. Allow max hold to run for at least 60 seconds, or longer as needed to allow the trace to stabilize.

26 dB Bandwidth

- a. Set RBW = approximately 1 % of the emission bandwidth.
- b. Set the VBW > RBW.
- c. Detector = Peak.
- d. Trace mode = max hold.
- e. Measure the maximum width of the emission that is 26 dB down from the peak of the emission. Compare this with the RBW setting of the analyzer. Readjust RBW and repeat measurement as needed until the RBW/EBW ratio is approximately 1 %.

4.3.5 Deviation from Test Standard

No deviation.

4.3.6 EUT Operating Conditions

The software provided by client to enable the EUT under transmission condition continuously at lowest, middle and highest channel frequencies individually.

4.3.7 Test Results

Power Output:

802.11a

Channel	Frequency (MHz)	Maximum Conducted Power (mW)	Maximum Conducted Power (dBm)	Power Limit (dBm)	Pass / Fail
36	5180	58.21	17.65	24	Pass
40	5200	64.863	18.12	24	Pass
48	5240	67.453	18.29	24	Pass
52	5260	66.527	18.23	24	Pass
60	5300	68.707	18.37	24	Pass
64	5320	60.674	17.83	24	Pass
100	5500	39.174	15.93	24	Pass
116	5580	66.681	18.24	24	Pass
140	5700	39.628	15.98	24	Pass
149	5745	23.878	13.78	30	Pass
157	5785	70.469	18.48	30	Pass
165	5825	59.293	17.73	30	Pass

Note:

For U-NII-2A, U-NII-2C Band:

1. $11 \text{ dBm} + 10\log(22.50) = 24.52 \text{ dBm} > 24 \text{ dBm}$.
2. $11 \text{ dBm} + 10\log(22.40) = 24.50 \text{ dBm} > 24 \text{ dBm}$.
3. $11 \text{ dBm} + 10\log(22.82) = 24.58 \text{ dBm} > 24 \text{ dBm}$.
4. $11 \text{ dBm} + 10\log(23.19) = 24.65 \text{ dBm} > 24 \text{ dBm}$.
5. $11 \text{ dBm} + 10\log(22.39) = 24.50 \text{ dBm} > 24 \text{ dBm}$.
6. $11 \text{ dBm} + 10\log(22.94) = 24.61 \text{ dBm} > 24 \text{ dBm}$.

802.11n (HT20)

Channel	Frequency (MHz)	Maximum Conducted Power (mW)	Maximum Conducted Power (dBm)	Power Limit (dBm)	Pass / Fail
36	5180	62.23	17.94	24	Pass
40	5200	68.549	18.36	24	Pass
48	5240	66.222	18.21	24	Pass
52	5260	69.343	18.41	24	Pass
60	5300	70.469	18.48	24	Pass
64	5320	62.661	17.97	24	Pass
100	5500	38.815	15.89	24	Pass
116	5580	70.632	18.49	24	Pass
140	5700	39.084	15.92	24	Pass
149	5745	24.322	13.86	30	Pass
157	5785	68.391	18.35	30	Pass
165	5825	62.23	17.94	30	Pass

Note:

For U-NII-2A, U-NII-2C Band:

1. $11 \text{ dBm} + 10\log (23.69) = 24.75 \text{ dBm} > 24 \text{ dBm}$.
2. $11 \text{ dBm} + 10\log (23.22) = 24.66 \text{ dBm} > 24 \text{ dBm}$.
3. $11 \text{ dBm} + 10\log (24.02) = 24.81 \text{ dBm} > 24 \text{ dBm}$.
4. $11 \text{ dBm} + 10\log (23.92) = 24.79 \text{ dBm} > 24 \text{ dBm}$.
5. $11 \text{ dBm} + 10\log (23.78) = 24.76 \text{ dBm} > 24 \text{ dBm}$.
6. $11 \text{ dBm} + 10\log (24.31) = 24.86 \text{ dBm} > 24 \text{ dBm}$.

802.11n (HT40)

Channel	Frequency (MHz)	Maximum Conducted Power (mW)	Maximum Conducted Power (dBm)	Power Limit (dBm)	Pass / Fail
38	5190	23.659	13.74	24	Pass
46	5230	36.898	15.67	24	Pass
54	5270	36.058	15.57	24	Pass
62	5310	23.281	13.67	24	Pass
102	5510	19.143	12.82	24	Pass
110	5550	39.628	15.98	24	Pass
134	5670	38.815	15.89	24	Pass
151	5755	24.774	13.94	30	Pass
159	5795	39.264	15.94	30	Pass

Note:

For U-NII-2A, U-NII-2C Band:

1. $11 \text{ dBm} + 10\log(42.43) = 27.28 \text{ dBm} > 24 \text{ dBm}$.
2. $11 \text{ dBm} + 10\log(42.47) = 27.28 \text{ dBm} > 24 \text{ dBm}$.
3. $11 \text{ dBm} + 10\log(42.38) = 27.27 \text{ dBm} > 24 \text{ dBm}$.
4. $11 \text{ dBm} + 10\log(42.55) = 27.29 \text{ dBm} > 24 \text{ dBm}$.
5. $11 \text{ dBm} + 10\log(42.22) = 27.26 \text{ dBm} > 24 \text{ dBm}$.

802.11ac (VHT80)

Channel	Frequency (MHz)	Maximum Conducted Power (mW)	Maximum Conducted Power (dBm)	Power Limit (dBm)	Pass / Fail
42	5210	30.974	14.91	24	Pass
58	5290	37.844	15.78	24	Pass
106	5530	37.411	15.73	24	Pass
122	5610	36.813	15.66	24	Pass
155	5775	30.409	14.83	30	Pass

Note:

For U-NII-2A, U-NII-2C Band:

1. $11 \text{ dBm} + 10\log(84.25) = 30.26 \text{ dBm} > 24 \text{ dBm}$.
2. $11 \text{ dBm} + 10\log(84.19) = 30.25 \text{ dBm} > 24 \text{ dBm}$.
3. $11 \text{ dBm} + 10\log(83.33) = 30.21 \text{ dBm} > 24 \text{ dBm}$.

26 dB Bandwidth:
802.11a

Channel	Frequency (MHz)	26 dBc Bandwidth (MHz)
36	5180	23.53
40	5200	23.05
48	5240	22.75
52	5260	22.50
60	5300	22.40
64	5320	22.82
100	5500	23.19
116	5580	22.39
140	5700	22.94

802.11n (HT20)

Channel	Frequency (MHz)	26 dBc Bandwidth (MHz)
36	5180	23.90
40	5200	24.02
48	5240	23.54
52	5260	23.69
60	5300	23.22
64	5320	24.02
100	5500	23.92
116	5580	23.78
140	5700	24.31

802.11n (HT40)

Channel	Frequency (MHz)	26 dBc Bandwidth (MHz)
38	5190	42.55
46	5230	42.43
54	5270	42.43
62	5310	42.47
102	5510	42.38
110	5550	42.55
134	5670	42.22

802.11ac (VHT80)

Channel	Frequency (MHz)	26 dBc Bandwidth (MHz)
42	5210	84.47
58	5290	84.25
106	5530	84.19
122	5610	83.33

Spectrum Plot of Worst Value

802.11a

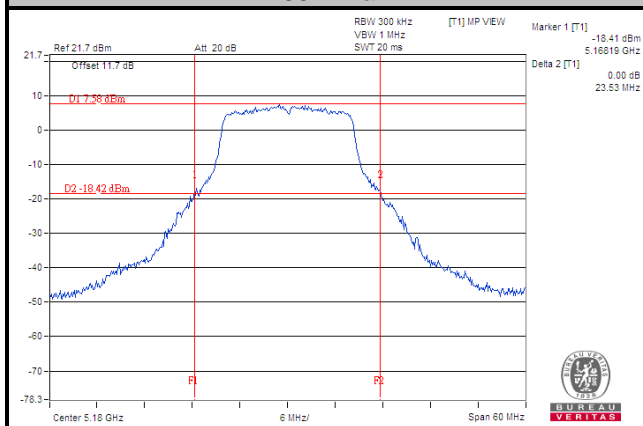

802.11n (HT20)

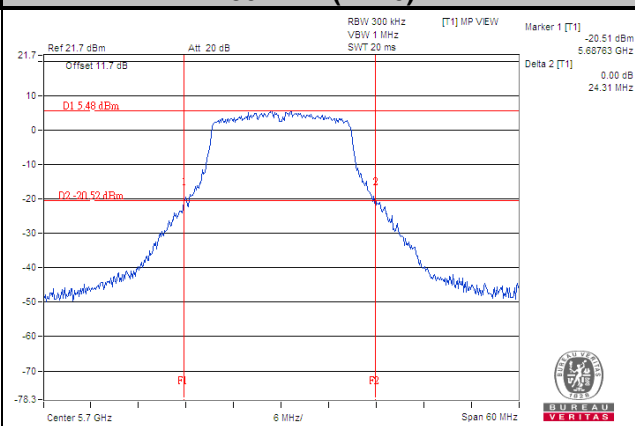

802.11n (HT40)

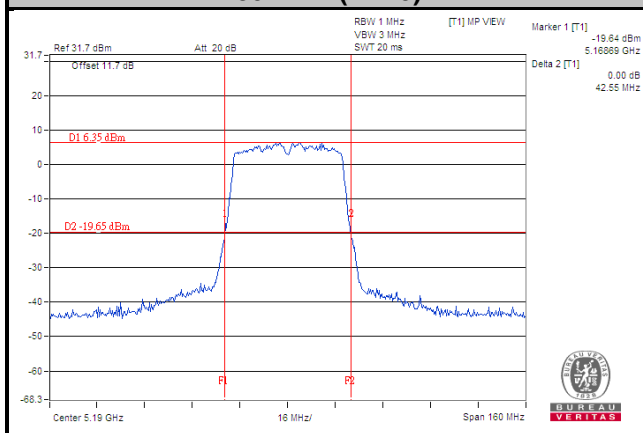

802.11ac (VHT80)

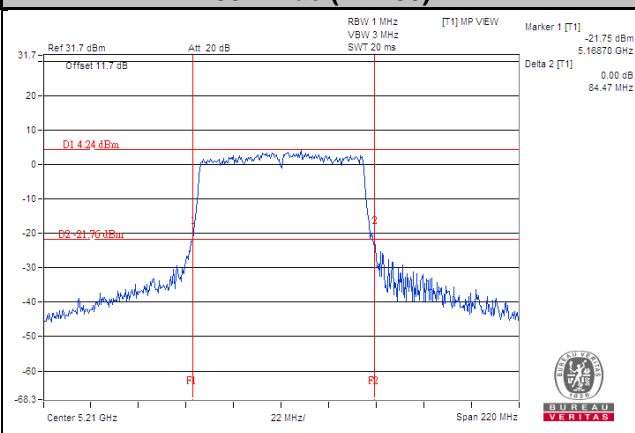

4.4 Occupied Bandwidth Measurement

4.4.1 Test Setup



4.4.2 Test Instruments

Refer to section 4.1.2 to get information of above instrument.

4.4.3 Test Procedure

The transmitter output was connected to the spectrum analyzer through an attenuator. The bandwidth of the fundamental frequency was measured by spectrum analyzer with resolution bandwidth in the range of 1 % to 5 % of the anticipated emission bandwidth, and a video bandwidth at least 3x the resolution bandwidth and set the detector to SAMPLE. The width of a frequency band such that, below the lower and above the upper frequency limits, the mean powers emitted are each equal to a specified percentage 0.5 % of the total mean power of a given emission.

4.4.4 Test Results

802.11a

Channel	Channel Frequency (MHz)	Occupied Bandwidth (MHz)
36	5180	16.68
40	5200	16.68
48	5240	16.68
52	5260	16.68
60	5300	16.80
64	5320	16.56
100	5500	16.68
116	5580	16.80
140	5700	16.68
149	5745	16.73
157	5785	16.64
165	5825	16.74

802.11n (HT20)

Channel	Channel Frequency (MHz)	Occupied Bandwidth (MHz)
36	5180	17.88
40	5200	17.88
48	5240	17.88
52	5260	18.00
60	5300	17.88
64	5320	17.88
100	5500	17.88
116	5580	17.88
140	5700	17.88
149	5745	17.79
157	5785	17.98
165	5825	17.88

802.11n (HT40)

Channel	Channel Frequency (MHz)	Occupied Bandwidth (MHz)
38	5190	36.60
46	5230	36.60
54	5270	36.60
62	5310	36.60
102	5510	36.60
110	5550	36.60
134	5670	36.60
151	5755	36.48
159	5795	36.60

802.11ac (VHT80)

Channel	Channel Frequency (MHz)	Occupied Bandwidth (MHz)
42	5210	75.84
58	5290	75.84
106	5530	75.84
122	5610	75.84
155	5775	75.76

Spectrum Plot of Worst Value

802.11a

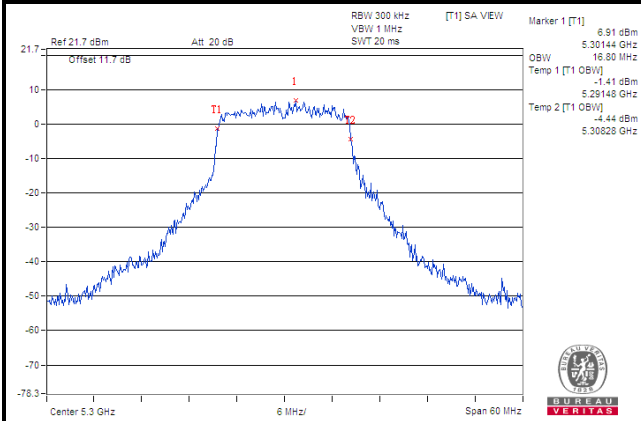

802.11n (HT20)

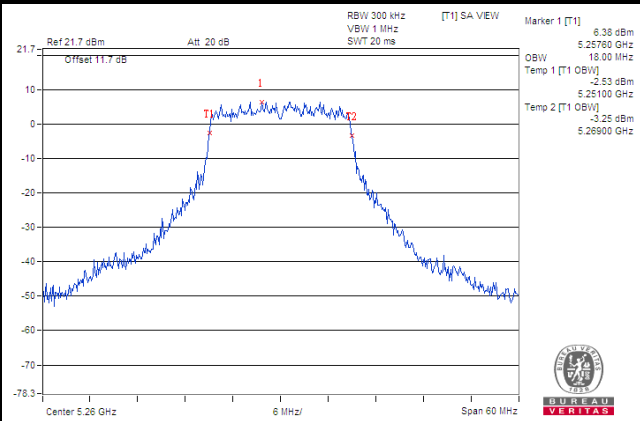

802.11n (HT40)

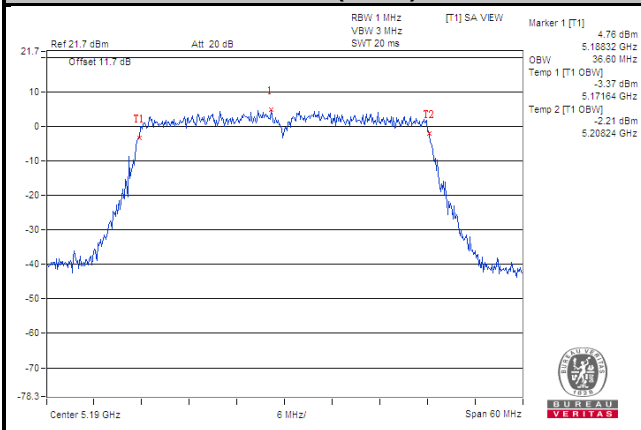

802.11ac (VHT80)

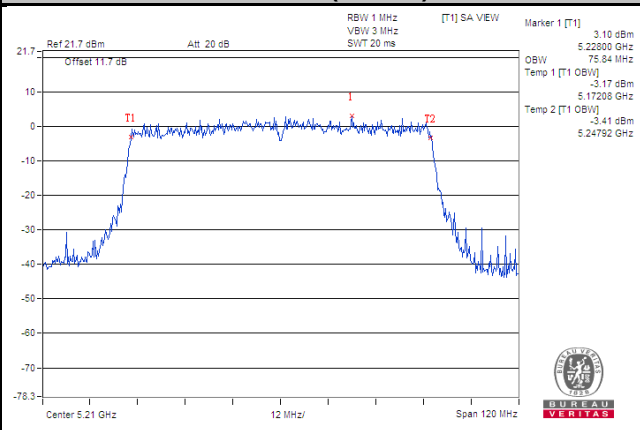

4.5 Peak Power Spectral Density Measurement

4.5.1 Limits of Peak Power Spectral Density Measurement

Operation Band	EUT Category		Limit
U-NII-1		Outdoor Access Point	17 dBm/MHz
		Fixed point-to-point Access Point	
		Indoor Access Point	
	√	Mobile and Portable client device	11 dBm/MHz
U-NII-2A		√	11 dBm/MHz
U-NII-2C		√	11 dBm/MHz
U-NII-3		√	30 dBm/500 kHz

4.5.2 Test Setup

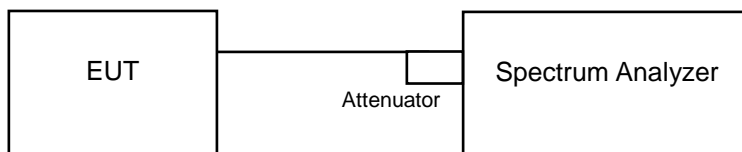

4.5.3 Test Instruments

Refer to section 4.1.3 to get information of above instrument.

4.5.4 Test Procedures

For U-NII-1, U-NII-2A, U-NII-2C band:

Using method SA-2

1. Set span to encompass the entire emission bandwidth (EBW) of the signal.
2. Set RBW = 1 MHz, Set VBW \geq 3 RBW, Detector = RMS
3. Sweep time = auto, trigger set to "free run".
4. Trace average at least 100 traces in power averaging mode.
5. Record the max value and add 10 log (1/duty cycle)

※For U-NII-3:

1. Set span to encompass the entire emission bandwidth (EBW) of the signal.
2. Set RBW = 500 kHz, Set VBW \geq 3 RBW, Detector = RMS
3. Use the peak marker function to determine the maximum power level in any 500 kHz band segment within the fundamental EBW.
4. Sweep time = auto, trigger set to "free run".
5. Trace average at least 100 traces in power averaging mode.
6. Record the max value and add 10 log (1/duty cycle)

4.5.5 Deviation from Test Standard

No deviation.

4.5.6 EUT Operating Conditions

The software provided by client to enable the EUT under transmission condition continuously at lowest, middle and highest channel frequencies individually.

4.5.7 Test Results

802.11a

Channel	Frequency (MHz)	PSD w/o Duty Factor (dBm/MHz)	Duty Factor (dB)	PSD with Duty Factor (dBm/MHz)	Maximum Limit (dBm/MHz)	Pass / Fail
36	5180	1.61	0.29	1.90	11	Pass
40	5200	2.13	0.29	2.42	11	Pass
48	5240	2.17	0.29	2.46	11	Pass
52	5260	2.15	0.29	2.44	11	Pass
60	5300	2.26	0.29	2.55	11	Pass
64	5320	1.85	0.29	2.14	11	Pass
100	5500	0.22	0.29	0.51	11	Pass
116	5580	2.51	0.29	2.80	11	Pass
140	5700	0.08	0.29	0.37	11	Pass

Note: Refer to section 3.3 for duty cycle spectrum plot.

802.11n (HT20)

Channel	Frequency (MHz)	PSD w/o Duty Factor (dBm/MHz)	Duty Factor (dB)	PSD with Duty Factor (dBm/MHz)	Maximum Limit (dBm/MHz)	Pass / Fail
36	5180	2.05	0.64	2.69	11	Pass
40	5200	2.51	0.64	3.15	11	Pass
48	5240	1.96	0.64	2.60	11	Pass
52	5260	2.48	0.64	3.12	11	Pass
60	5300	2.33	0.64	2.97	11	Pass
64	5320	2.23	0.64	2.87	11	Pass
100	5500	0.31	0.64	0.95	11	Pass
116	5580	2.43	0.64	3.07	11	Pass
140	5700	0.17	0.64	0.81	11	Pass

Note: Refer to section 3.3 for duty cycle spectrum plot.

802.11n (HT40)

Channel	Frequency (MHz)	PSD w/o Duty Factor (dBm/MHz)	Duty Factor (dB)	PSD with Duty Factor (dBm/MHz)	Maximum Limit (dBm/MHz)	Pass / Fail
38	5190	-5.25	0.82	-4.43	11	Pass
46	5230	-3.59	0.82	-2.77	11	Pass
54	5270	-3.62	0.82	-2.80	11	Pass
62	5310	-5.42	0.82	-4.60	11	Pass
102	5510	-5.98	0.82	-5.16	11	Pass
110	5550	-3.56	0.82	-2.74	11	Pass
134	5670	-3.25	0.82	-2.43	11	Pass

Note: Refer to section 3.3 for duty cycle spectrum plot.

802.11ac (VHT80)

Channel	Frequency (MHz)	PSD w/o Duty Factor (dBm/MHz)	Duty Factor (dB)	PSD with Duty Factor (dBm/MHz)	Maximum Limit (dBm/MHz)	Pass / Fail
42	5210	-7.82	1.14	-6.68	11	Pass
58	5290	-6.67	1.14	-5.53	11	Pass
106	5530	-5.96	1.14	-4.82	11	Pass
122	5610	-6.11	1.14	-4.97	11	Pass

Note: Refer to section 3.3 for duty cycle spectrum plot.

Spectrum Plot of Worst Value

802.11a

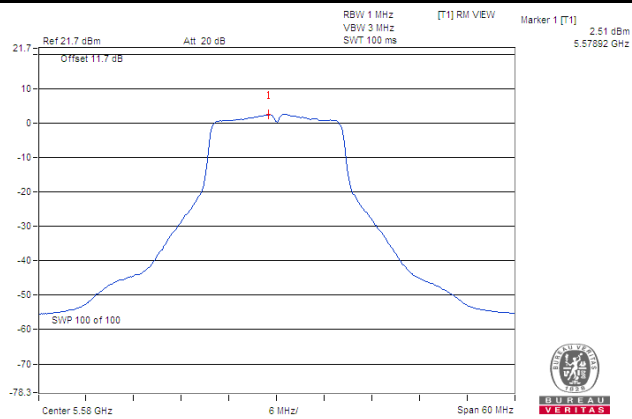

802.11n (HT20)

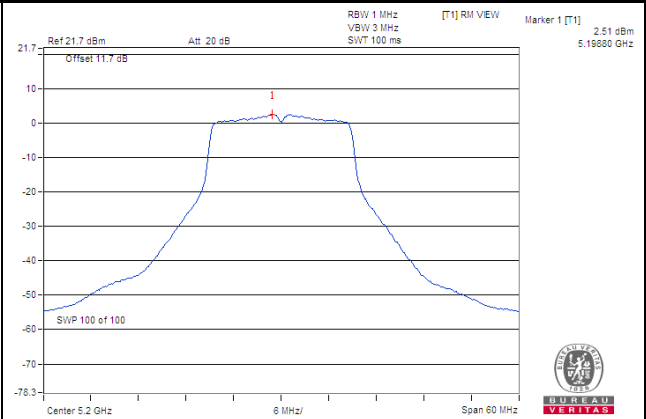

802.11n (HT40)

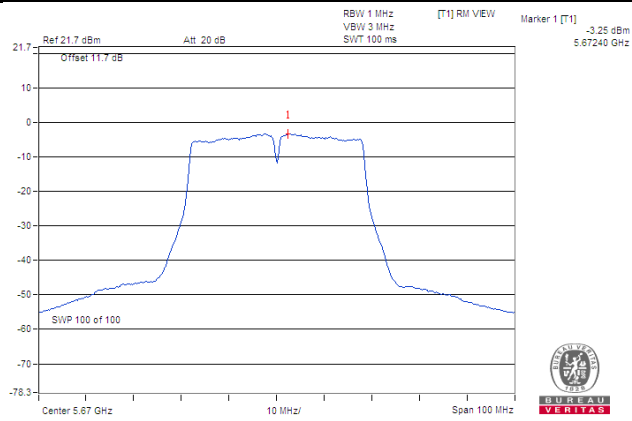

802.11ac (VHT80)

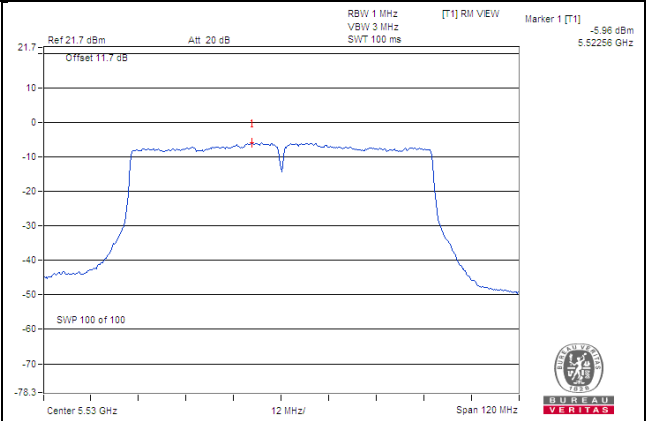

For U-NII-3 Band

802.11a

Channel	Frequency (MHz)	PSD w/o Duty Factor (dBm/300 kHz)	PSD w/o Duty Factor (dBm/500 kHz)	Duty Factor (dB)	PSD with Duty Factor (dBm/500 kHz)	Limit (dBm/500 kHz)	Pass / Fail
149	5745	-8.60	-6.38	0.29	-6.09	30	Pass
157	5785	-3.89	-1.67	0.29	-1.38	30	Pass
165	5825	-4.32	-2.10	0.29	-1.81	30	Pass

Note: Refer to section 3.3 for duty cycle spectrum plot.

802.11n (HT20)

Channel	Frequency (MHz)	PSD w/o Duty Factor (dBm/300 kHz)	PSD w/o Duty Factor (dBm/500 kHz)	Duty Factor (dB)	PSD with Duty Factor (dBm/500 kHz)	Limit (dBm/500 kHz)	Pass / Fail
149	5745	-8.03	-6.08	0.64	-5.44	30	Pass
157	5785	-4.08	-1.86	0.64	-1.22	30	Pass
165	5825	-4.59	-2.37	0.64	-1.73	30	Pass

Note: Refer to section 3.3 for duty cycle spectrum plot.

802.11n (HT40)

Channel	Frequency (MHz)	PSD w/o Duty Factor (dBm/300 kHz)	PSD w/o Duty Factor (dBm/500 kHz)	Duty Factor (dB)	PSD with Duty Factor (dBm/500 kHz)	Limit (dBm/500 kHz)	Pass / Fail
151	5755	-12.16	-9.94	0.82	-9.12	30	Pass
159	5795	-9.89	-7.67	0.82	-6.85	30	Pass

Note: Refer to section 3.3 for duty cycle spectrum plot.

802.11ac (VHT80)

Channel	Frequency (MHz)	PSD w/o Duty Factor (dBm/300 kHz)	PSD w/o Duty Factor (dBm/500 kHz)	Duty Factor (dB)	PSD with Duty Factor (dBm/500 kHz)	Limit (dBm/500 kHz)	Pass / Fail
155	5775	-14.11	-11.89	1.14	-10.75	30	Pass

Note: Refer to section 3.3 for duty cycle spectrum plot.

Spectrum Plot of Worst Value

802.11a

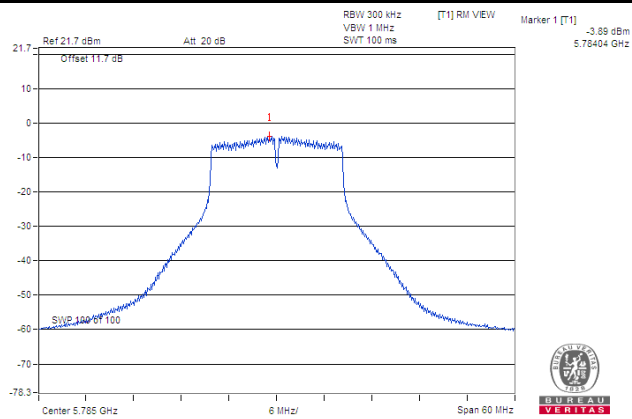

802.11n (HT20)

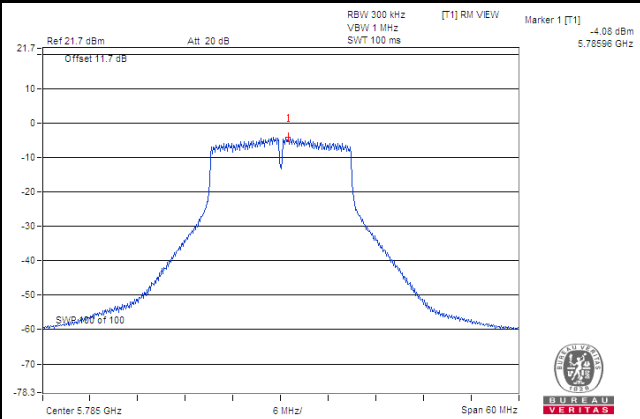

802.11n (HT40)

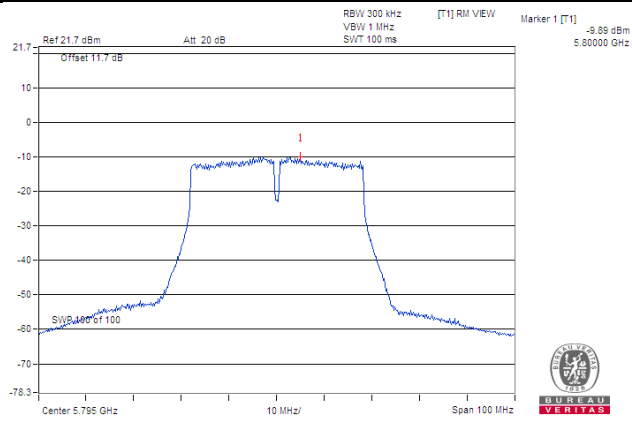

802.11ac (VHT80)

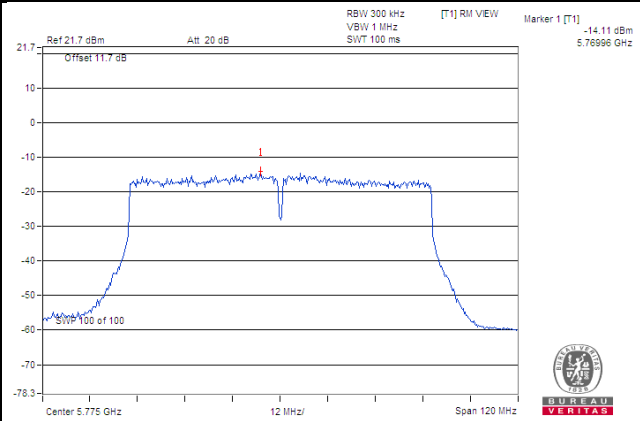

4.6 Frequency Stability

4.6.1 Limit of Frequency Stability Measurement

The frequency of the carrier signal shall be maintained within band of operation.

4.6.2 Test Setup

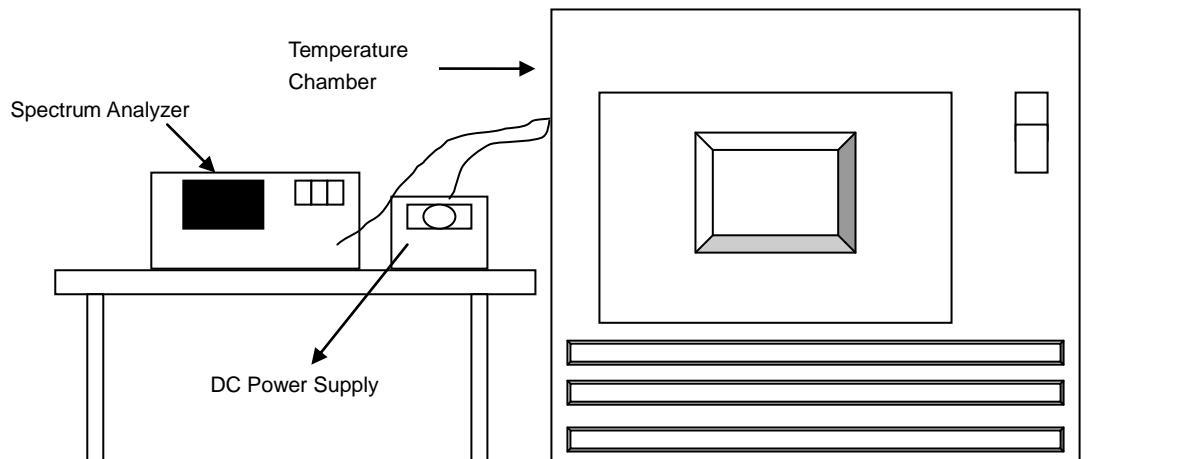

4.6.3 Test Instruments

Refer to section 4.1.3 to get information of above instrument.

4.6.4 Test Procedure

- To ensure emission at the band edge is maintained within the authorized band, those values shall be measured by radiation emissions at upper and lower frequency points, and finally compensated by frequency deviation as procedures below.
- The EUT was operated at the maximum output power, and connected to the spectrum analyzer, which is set to maximum hold function and peak detector. The peak value of the power envelope was measured and noted. The upper and lower frequency points were respectively measured relatively 10 dB lower than the measured peak value.
- The frequency deviation was calculated by adding the upper frequency point and the lower frequency point divided by two. Those detailed values of frequency deviation are provided in table below.

4.6.5 Deviation from Test Standard

No deviation.

4.6.6 EUT Operating Condition

Set the EUT transmit at un-modulation mode to test frequency stability.

4.6.7 Test Results

Frequency Stability Versus Temp.									
Operating Frequency: 5180 MHz									
Temp. (°C)	Power Supply (Vdc)	0 Minute		2 Minute		5 Minute		10 Minute	
		Measured Frequency (MHz)	Result	Measured Frequency (MHz)	Result	Measured Frequency (MHz)	Result	Measured Frequency (MHz)	Result
60	3.8	5179.9831	PASS	5179.9835	PASS	5179.9851	PASS	5179.9858	PASS
50	3.8	5179.973	PASS	5179.9774	PASS	5179.9758	PASS	5179.9768	PASS
40	3.8	5180.0084	PASS	5180.0071	PASS	5180.0081	PASS	5180.0094	PASS
30	3.8	5180.0117	PASS	5180.0097	PASS	5180.0099	PASS	5180.0133	PASS
20	3.8	5179.9835	PASS	5179.9833	PASS	5179.9844	PASS	5179.9833	PASS
10	3.8	5179.9914	PASS	5179.9901	PASS	5179.9921	PASS	5179.9915	PASS
0	3.8	5179.9752	PASS	5179.9769	PASS	5179.9763	PASS	5179.976	PASS
-10	3.8	5179.9894	PASS	5179.9861	PASS	5179.9886	PASS	5179.9901	PASS
-20	3.8	5179.9968	PASS	5179.9963	PASS	5179.998	PASS	5179.9957	PASS
-30	3.8	5179.9838	PASS	5179.9839	PASS	5179.9863	PASS	5179.9865	PASS

Frequency Stability Versus Temp.									
Operating Frequency: 5180 MHz									
Temp. (°C)	Power Supply (Vdc)	0 Minute		2 Minute		5 Minute		10 Minute	
		Measured Frequency (MHz)	Result	Measured Frequency (MHz)	Result	Measured Frequency (MHz)	Result	Measured Frequency (MHz)	Result
20	4.37	5179.9833	PASS	5179.984	PASS	5179.9841	PASS	5179.9831	PASS
	3.8	5179.9835	PASS	5179.9833	PASS	5179.9844	PASS	5179.9833	PASS
	3.23	5179.983	PASS	5179.9839	PASS	5179.9851	PASS	5179.983	PASS

4.7 6 dB Bandwidth Measurement

4.7.1 Limits of 6 dB Bandwidth Measurement

The minimum of 6 dB Bandwidth Measurement is 0.5 MHz.

4.7.2 Test Setup

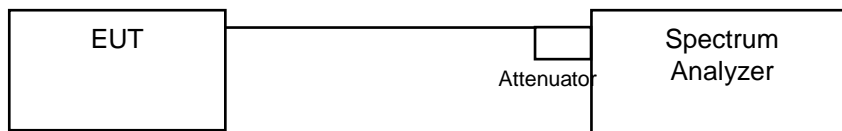

4.7.3 Test Instruments

Refer to section 4.1.3 to get information of above instrument.

4.7.4 Test Procedure

MEASUREMENT PROCEDURE REF

- Set resolution bandwidth (RBW) = 100 kHz
- Set the video bandwidth (VBW) $\geq 3 \times$ RBW, Detector = Peak.
- Trace mode = max hold.
- Sweep = auto couple.
- Measure the maximum width of the emission that is constrained by the frequencies associated with the two amplitude points (upper and lower) that are attenuated by 6 dB relative to the maximum level measured in the fundamental emission

4.7.5 Deviation from Test Standard

No deviation.

4.7.6 EUT Operating Condition

The software provided by client to enable the EUT under transmission condition continuously at lowest, middle and highest channel frequencies individually.

4.7.7 Test Results

802.11a

Channel	Frequency (MHz)	6 dB Bandwidth (MHz)	Minimum Limit (MHz)	Pass / Fail
149	5745	15.17	0.5	Pass
157	5785	15.69	0.5	Pass
165	5825	15.66	0.5	Pass

802.11n (HT20)

Channel	Frequency (MHz)	6 dB Bandwidth (MHz)	Minimum Limit (MHz)	Pass / Fail
149	5745	15.67	0.5	Pass
157	5785	15.15	0.5	Pass
165	5825	15.74	0.5	Pass

802.11n (HT40)

Channel	Frequency (MHz)	6 dB Bandwidth (MHz)	Minimum Limit (MHz)	Pass / Fail
151	5755	35.73	0.5	Pass
159	5795	35.34	0.5	Pass

802.11ac (VHT80)

Channel	Frequency (MHz)	6 dB Bandwidth (MHz)	Minimum Limit (MHz)	Pass / Fail
155	5775	75.50	0.5	Pass

Spectrum Plot of Worst Value

802.11a

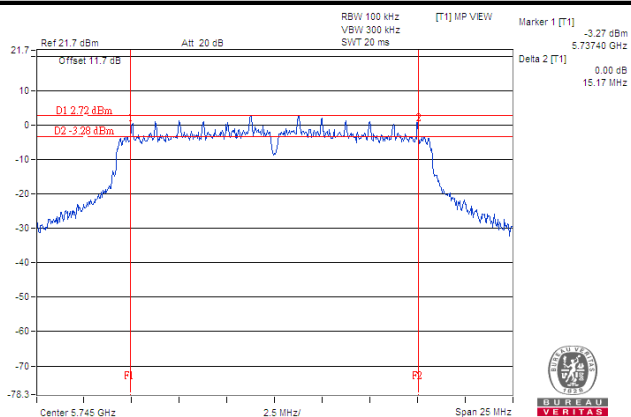

802.11n (HT20)

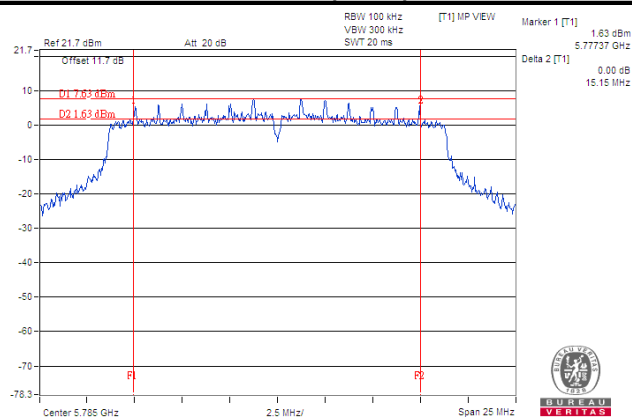

802.11n (HT40)

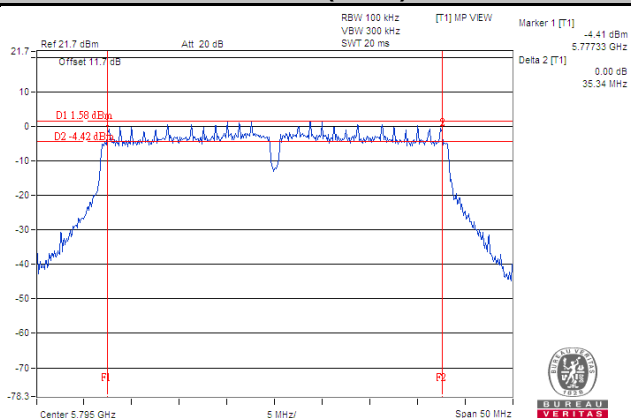

802.11ac (VHT80)

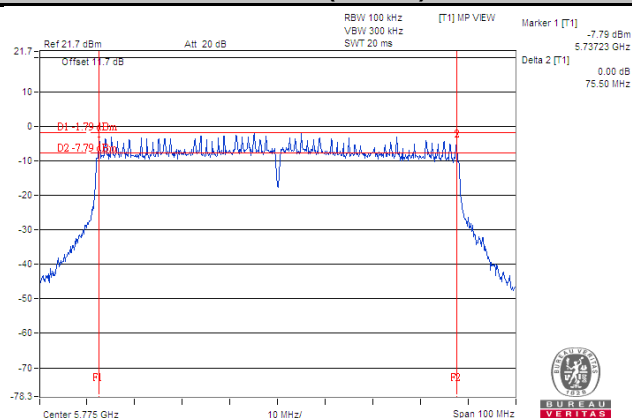

5 Pictures of Test Arrangements

Please refer to the attached file (Test Setup Photo).

Annex A- Radiated Out of Band Emission (OOBE) Measurement (For U-NII-3 band)

802.11a

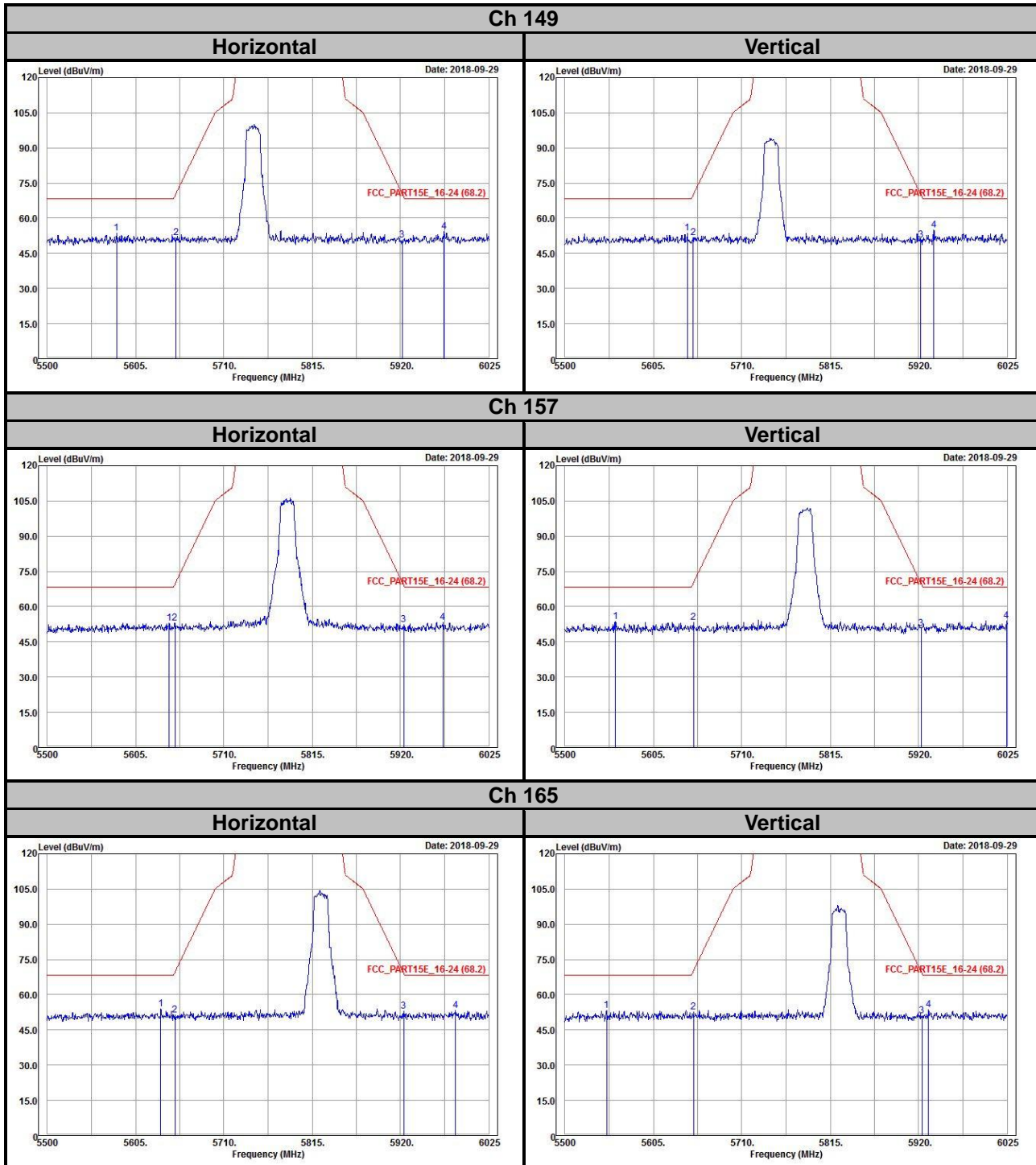

802.11n (HT20)

Ch 149

Horizontal

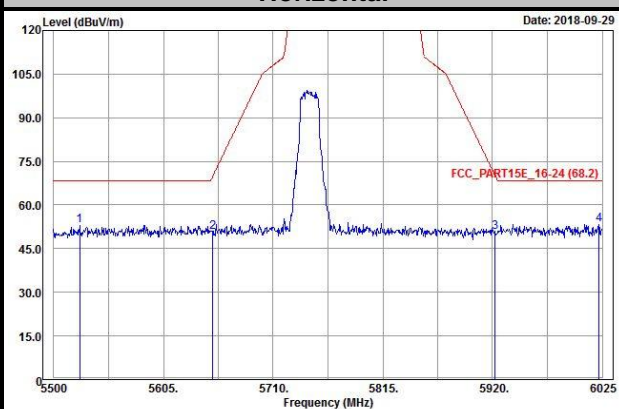

Vertical

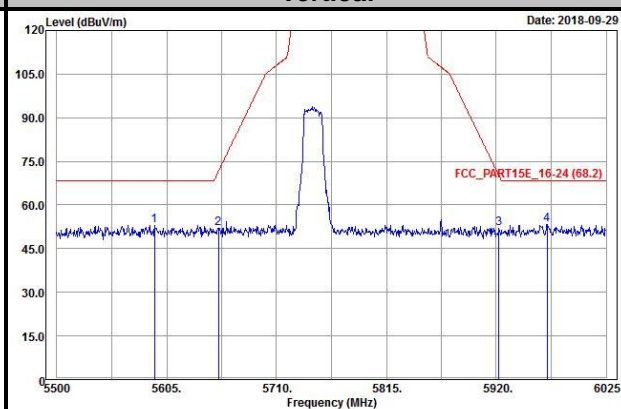

Ch 157

Horizontal

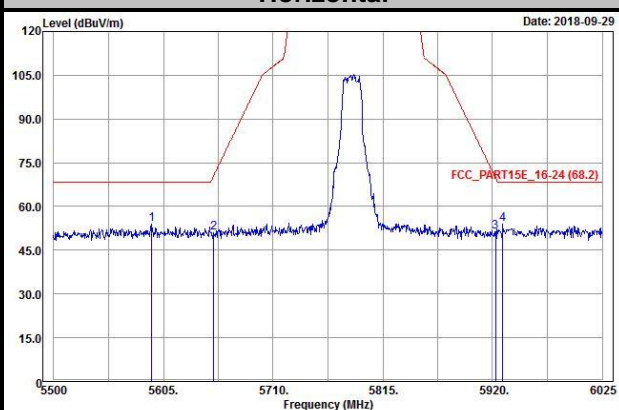

Vertical

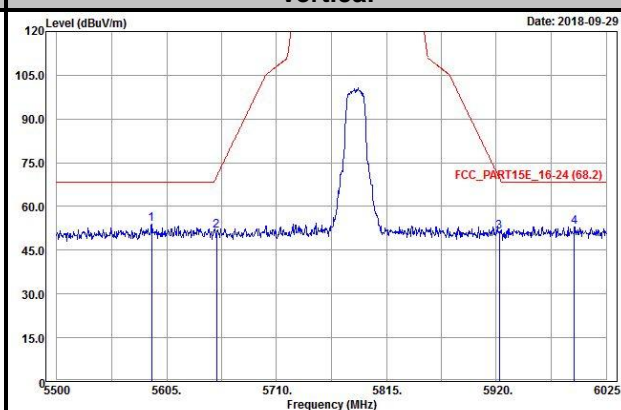

Ch 165

Horizontal

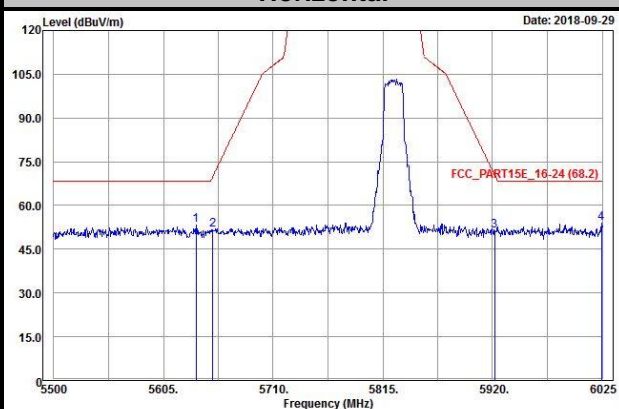

Vertical

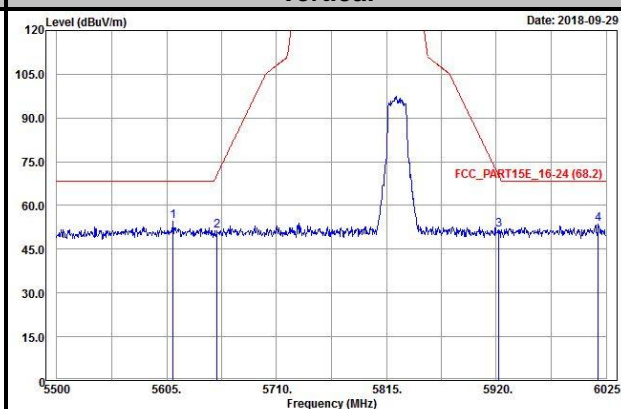

802.11n (HT40)

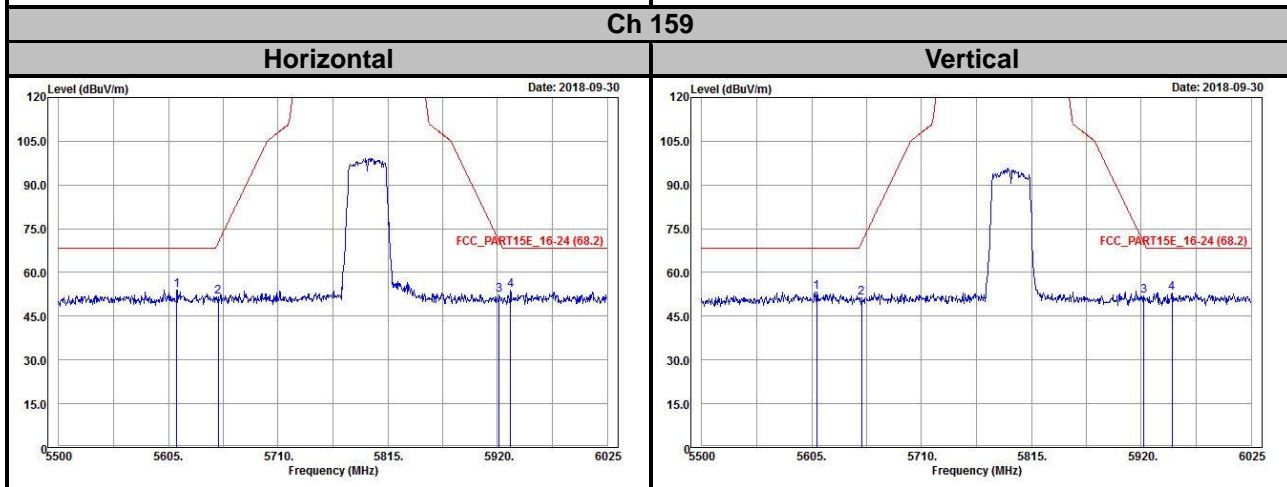
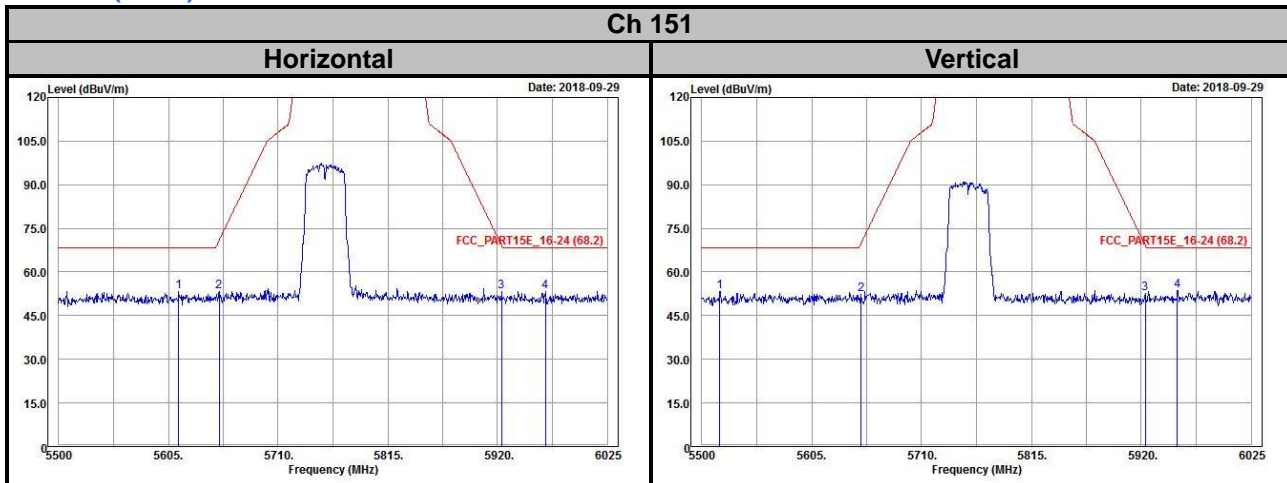

802.11ac (VHT80)

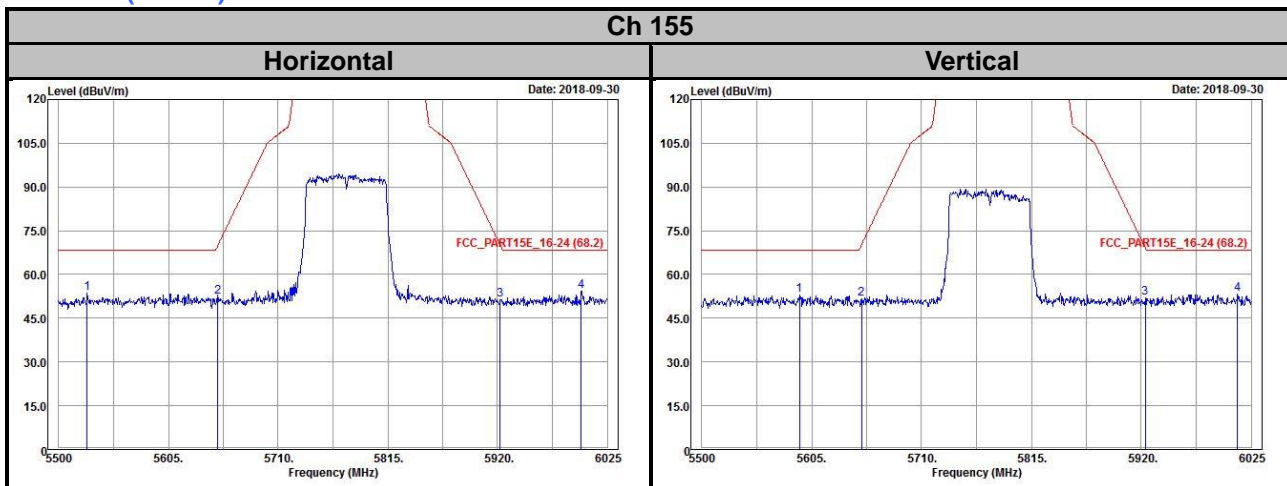

Appendix – Information on the Testing Laboratories

We, Bureau Veritas Consumer Products Services (H.K.) Ltd., Taoyuan Branch, were founded in 1988 to provide our best service in EMC, Radio, Telecom and Safety consultation. Our laboratories are FCC recognized accredited test firms and accredited according to ISO/IEC 17025.

If you have any comments, please feel free to contact us at the following:

Linko EMC/RF Lab

Tel: 886-2-26052180

Fax: 886-2-26051924

Hsin Chu EMC/RF/Telecom Lab

Tel: 886-3-6668565

Fax: 886-3-6668323

Hwa Ya EMC/RF/Safety

Tel: 886-3-3183232

Fax: 886-3-3270892

Email: service.adt@tw.bureauveritas.com

Web Site: www.bureauveritas-adt.com

The address and road map of all our labs can be found in our web site also.

--- END ---