



FCC TEST REPORT (15.247)

REPORT NO.: RF140221C18-7
MODEL NO.: E6782
FCC ID: V65E6782
RECEIVED: Feb. 21, 2014
TESTED: Mar. 04, 2014 ~ Mar. 15, 2014
ISSUED: Mar. 20, 2014

APPLICANT: Kyocera Corporation c/o Kyocera Communications, Inc.

ADDRESS: 9520 Towne Centre Drive, Suite #200, San Diego, CA 92121

ISSUED BY: Bureau Veritas Consumer Products Services
(H.K.) Ltd., Taoyuan Branch

LAB ADDRESS: No. 47, 14th Ling, Chia Pau Vil., Lin Kou Dist.,
New Taipei City, Taiwan (R.O.C)

TEST LOCATION: No. 19, Hwa Ya 2nd Rd, Wen Hwa Tsuen, Kwei
Shan Hsiang, Taoyuan Hsien 333, Taiwan, R.O.C.

This report should not be used by the client to claim product certification, approval, or endorsement by TAF or any government agencies.



This report is for your exclusive use. Any copying or replication of this report to or for any other person or entity, or use of our name or trademark, is permitted only with our prior written permission. This report sets forth our findings solely with respect to the test samples identified herein. The results set forth in this report are not indicative or representative of the quality or characteristics of the lot from which a test sample was taken or any similar or identical product unless specifically and expressly noted. Our report includes all of the tests requested by you and the results thereof based upon the information that you provided to us. You have 60 days from date of issuance of this report to notify us of any material error or omission caused by our negligence, provided, however, that such notice shall be in writing and shall specifically address the issue you wish to raise. A failure to raise such issue within the prescribed time shall constitute your unqualified acceptance of the completeness of this report, the tests conducted and the correctness of the report contents. Unless specific mention, the uncertainty of measurement has been explicitly taken into account to declare the compliance or non-compliance to the specification.



TABLE OF CONTENTS

- RELEASE CONTROL RECORD 5
- 1. CERTIFICATION..... 6
- 2. SUMMARY OF TEST RESULTS 7
 - 2.1 MEASUREMENT UNCERTAINTY 7
- 3. GENERAL INFORMATION..... 8
 - 3.1 GENERAL DESCRIPTION OF EUT..... 8
 - 3.2 DESCRIPTION OF TEST MODES..... 10
 - 3.2.1 TEST MODE APPLICABILITY AND TESTED CHANNEL DETAIL..... 11
 - 3.3 DESCRIPTION OF SUPPORT UNITS..... 15
 - 3.3.1 CONFIGURATION OF SYSTEM UNDER TEST 15
 - 3.4 DUTY CYCLE TEST SIGNAL..... 16
 - 3.5 GENERAL DESCRIPTION OF APPLIED STANDARDS..... 17
- 4. TEST TYPES AND RESULTS (FOR 2.4GHz BAND)..... 18
 - 4.1 RADIATED EMISSION AND BANDEDGE MEASUREMENT 18
 - 4.1.1 LIMITS OF RADIATED EMISSION AND BANDEDGE MEASUREMENT 18
 - 4.1.2 TEST INSTRUMENTS..... 19
 - 4.1.3 TEST PROCEDURES 20
 - 4.1.4 DEVIATION FROM TEST STANDARD 20
 - 4.1.5 TEST SETUP 21
 - 4.1.6 EUT OPERATING CONDITIONS 21
 - 4.1.7 TEST RESULTS..... 22
 - 4.2 CONDUCTED EMISSION MEASUREMENT 32
 - 4.2.1 LIMITS OF CONDUCTED EMISSION MEASUREMENT 32
 - 4.2.2 TEST INSTRUMENTS..... 32
 - 4.2.3 TEST PROCEDURES 33
 - 4.2.4 DEVIATION FROM TEST STANDARD 33
 - 4.2.5 TEST SETUP 33
 - 4.2.6 EUT OPERATING CONDITIONS 33
 - 4.2.7 TEST RESULTS..... 34
 - 4.3 6dB BANDWIDTH MEASUREMENT 36
 - 4.3.1 LIMITS OF 6dB BANDWIDTH MEASUREMENT 36
 - 4.3.2 TEST SETUP 36
 - 4.3.3 TEST INSTRUMENTS..... 36
 - 4.3.4 TEST PROCEDURE 36
 - 4.3.5 DEVIATION FROM TEST STANDARD 36
 - 4.3.6 EUT OPERATING CONDITIONS 36
 - 4.3.7 TEST RESULTS..... 37
 - 4.4 CONDUCTED OUTPUT POWER 39
 - 4.4.1 LIMITS OF CONDUCTED OUTPUT POWER MEASUREMENT 39
 - 4.4.2 TEST SETUP 39
 - 4.4.3 TEST INSTRUMENTS..... 39
 - 4.4.4 TEST PROCEDURES 39
 - 4.4.5 DEVIATION FROM TEST STANDARD 39
 - 4.4.6 EUT OPERATING CONDITIONS 39
 - 4.4.7 TEST RESULTS..... 40
 - 4.5 POWER SPECTRAL DENSITY MEASUREMENT..... 41
 - 4.5.1 LIMITS OF POWER SPECTRAL DENSITY MEASUREMENT 41
 - 4.5.2 TEST SETUP 41
 - 4.5.3 TEST INSTRUMENTS..... 41
 - 4.5.4 TEST PROCEDURE 41
 - 4.5.5 DEVIATION FROM TEST STANDARD 41
 - 4.5.6 EUT OPERATING CONDITION..... 41



4.5.7	TEST RESULTS.....	42
4.6	CONDUCTED OUT OF BAND EMISSION MEASUREMENT	44
4.6.1	LIMITS OF CONDUCTED OUT OF BAND EMISSION MEASUREMENT	44
4.6.2	TEST SETUP	44
4.6.3	TEST INSTRUMENTS	44
4.6.4	TEST PROCEDURE	44
4.6.5	DEVIATION FROM TEST STANDARD	44
4.6.6	EUT OPERATING CONDITION.....	44
4.6.7	TEST RESULTS.....	45
5.	TEST TYPES AND RESULTS (FOR 5.0GHz BAND)	48
5.1	RADIATED EMISSION AND BANDEDGE MEASUREMENT	48
5.1.1	LIMITS OF RADIATED EMISSION AND BANDEDGE MEASUREMENT	48
5.1.2	TEST INSTRUMENTS.....	49
5.1.3	TEST PROCEDURES	49
5.1.4	DEVIATION FROM TEST STANDARD	49
5.1.5	TEST SETUP	49
5.1.6	EUT OPERATING CONDITIONS	49
5.1.7	TEST RESULTS.....	50
5.2	CONDUCTED EMISSION MEASUREMENT	60
5.2.1	LIMITS OF CONDUCTED EMISSION MEASUREMENT	60
5.2.2	TEST INSTRUMENTS.....	60
5.2.3	TEST PROCEDURES	60
5.2.4	DEVIATION FROM TEST STANDARD	60
5.2.5	TEST SETUP	60
5.2.6	EUT OPERATING CONDITIONS	60
5.2.7	TEST RESULTS.....	61
5.3	6dB BANDWIDTH MEASUREMENT	63
5.3.1	LIMITS OF 6dB BANDWIDTH MEASUREMENT	63
5.3.2	TEST SETUP	63
5.3.3	TEST INSTRUMENTS.....	63
5.3.4	TEST PROCEDURE	63
5.3.5	DEVIATION FROM TEST STANDARD	63
5.3.6	EUT OPERATING CONDITIONS	63
5.3.7	TEST RESULTS.....	64
5.4	MAXIMUM OUTPUT POWER	66
5.4.1	LIMITS OF MAXIMUM OUTPUT POWER MEASUREMENT	66
5.4.2	TEST SETUP	66
5.4.3	INSTRUMENTS	66
5.4.4	TEST PROCEDURES	66
5.4.5	DEVIATION FROM TEST STANDARD	66
5.4.6	EUT OPERATING CONDITIONS	66
5.4.7	TEST RESULTS.....	67
5.5	POWER SPECTRAL DENSITY MEASUREMENT.....	68
5.5.1	LIMITS OF POWER SPECTRAL DENSITY MEASUREMENT	68
5.5.2	TEST SETUP	68
5.5.3	TEST INSTRUMENTS.....	68
5.5.4	TEST PROCEDURE	68
5.5.5	DEVIATION FROM TEST STANDARD	68
5.5.6	EUT OPERATING CONDITION.....	68
5.5.7	TEST RESULTS.....	69
5.6	CONDUCTED OUT OF BAND EMISSION MEASUREMENT	71
5.6.1	LIMITS OF OUT OF BAND EMISSION MEASUREMENT	71
5.6.2	TEST SETUP	71
5.6.3	TEST INSTRUMENTS.....	71
5.6.4	TEST PROCEDURE	71



A D T

5.6.5	DEVIATION FROM TEST STANDARD	71
5.6.6	EUT OPERATING CONDITION.....	71
5.6.7	TEST RESULTS.....	71
6.	PHOTOGRAPHS OF THE TEST CONFIGURATION.....	75
7.	INFORMATION ON THE TESTING LABORATORIES	76
8.	APPENDIX A – MODIFICATIONS RECORDERS FOR ENGINEERING CHANGES TO THE EUT BY THE LAB	77



A D T

RELEASE CONTROL RECORD

ISSUE NO.	REASON FOR CHANGE	DATE ISSUED
RF140221C18-7	Original release	Mar. 20, 2014

2. SUMMARY OF TEST RESULTS

The EUT has been tested according to the following specifications:

APPLIED STANDARD: FCC PART 15, SUBPART C (SECTION 15.247)			
STANDARD SECTION	TEST TYPE	RESULT	REMARK
15.207	AC Power Conducted Emission	PASS	Meet the requirement of limit. Minimum passing margin is -1.22dB at 13.55859MHz.
15.247(d) 15.209	Radiated Emissions	PASS	Meet the requirement of limit. Minimum passing margin is -0.49dB at 2483.5MHz.
15.247(d)	Band Edge Measurement	PASS	Meet the requirement of limit.
15.247(a)(2)	6dB bandwidth	PASS	Meet the requirement of limit.
15.247(b)	Conducted power	PASS	Meet the requirement of limit.
15.247(e)	Power Spectral Density	PASS	Meet the requirement of limit.
15.203	Antenna Requirement	PASS	No antenna connector is used.

2.1 MEASUREMENT UNCERTAINTY

Where relevant, the following measurement uncertainty levels have been estimated for tests performed on the EUT as specified in CISPR 16-4-2:

MEASUREMENT	FREQUENCY	UNCERTAINTY
Conducted emissions	9kHz~30MHz	2.44 dB
Radiated emissions	30MHz ~ 200MHz	2.93 dB
	200MHz ~1000MHz	2.95 dB
	1GHz ~ 18GHz	2.26 dB
	18GHz ~ 40GHz	1.94 dB

This uncertainty represents an expanded uncertainty expressed at approximately the 95% confidence level using a coverage factor of $k = 2$.



A D T

3. GENERAL INFORMATION

3.1 GENERAL DESCRIPTION OF EUT

EUT	PDA Phone
MODEL NO.	E6782
POWER SUPPLY	5.0Vdc (adapter or host equipment) 3.8Vdc (battery)
MODULATION TYPE	CCK, DQPSK, DBPSK for DSSS 256QAM, 64QAM, 16QAM, QPSK, BPSK for OFDM
MODULATION TECHNOLOGY	DSSS, OFDM
TRANSFER RATE	802.11b: 11.0 / 5.5 / 2.0 / 1.0 Mbps 802.11g: 54.0 / 48.0 / 36.0 / 24.0 / 18.0 / 12.0 / 9.0 / 6.0 Mbps 802.11a: 54.0 / 48.0 / 36.0 / 24.0 / 18.0 / 12.0 / 9.0 / 6.0 Mbps 802.11n: up to MCS7 802.11ac: up to V9
OPERATING FREQUENCY	2.4GHz: 2412 ~ 2462MHz 5.0GHz: 5745 ~ 5825MHz
NUMBER OF CHANNEL	2.4GHz: 11 for 802.11b, 802.11g, 802.11n (20MHz) 5.0GHz: 5 for 802.11a, 802.11n (20MHz) 2 for 802.11n (40MHz) 1 for 802.11ac (80MHz)
OUTPUT POWER	152.757mW for 2412 ~ 2462MHz 178.649mW for 5745 ~ 5825MHz
ANTENNA TYPE	2.4GHz: Monopole antenna with -1dBi gain 5.0GHz: Monopole antenna with -1dBi gain
ANTENNA CONNECTOR	NA
DATA CABLE	Refer to Note as below
I/O PORTS	Refer to user's manual
ACCESSORY DEVICES	Refer to Note as below



A D T

NOTE:

1. The EUT contains following accessory devices.

ITEM	BRAND	MODEL	SPECIFICATION
Adapter	Kyocera	SCP-43ADT	I/P: 100-240Vac, 50/60Hz, 300mA O/P: 5Vdc, 1500mA
Battery	Kyocera	SCP-60LBPS	3.8Vdc, 3000Ah
USB Cable	Kyocera	SCP-15SDC	1.2m cable

2. The EUT provides one completed transmitter and one receiver.

MODULATION MODE	TX FUNCTION
802.11b	1TX
802.11g	1TX
802.11a	1TX
802.11n (20MHz)	1TX
802.11n (40MHz)	1TX
802.11ac (80MHz)	1TX

3. The above EUT information is declared by the manufacturer and for more detailed features description, please refer to the manufacturer's specifications or User's Manual.

3.2 DESCRIPTION OF TEST MODES

FOR 2.4GHz:

11 channels are provided for 802.11b, 802.11g and 802.11n (20MHz):

CHANNEL	FREQUENCY	CHANNEL	FREQUENCY
1	2412MHz	7	2442MHz
2	2417MHz	8	2447MHz
3	2422MHz	9	2452MHz
4	2427MHz	10	2457MHz
5	2432MHz	11	2462MHz
6	2437MHz		

FOR 5.0GHz (5745 ~ 5825MHz):

5 channels are provided for 802.11a, 802.11n (20MHz):

CHANNEL	FREQUENCY	CHANNEL	FREQUENCY
149	5745MHz	161	5805MHz
153	5765MHz	165	5825MHz
157	5785MHz		

2 channels are provided for 802.11n (40MHz):

CHANNEL	FREQUENCY	CHANNEL	FREQUENCY
151	5755MHz	159	5795MHz

1 channel is provided for 802.11ac (80MHz):

CHANNEL	FREQUENCY
155	5775MHz



3.2.1 TEST MODE APPLICABILITY AND TESTED CHANNEL DETAIL

WLAN 2.4GHz:

EUT CONFIGURE MODE	APPLICABLE TO				DESCRIPTION
	RE≥1G	RE<1G	PLC	APCM	
-	√	√	√	√	-

Where **RE≥1G:** Radiated Emission above 1GHz **RE<1G:** Radiated Emission below 1GHz
PLC: Power Line Conducted Emission **APCM:** Antenna Port Conducted Measurement

NOTE: The EUT had been pre-tested on the positioned of each 3 axis. The worst case was found when positioned on **X-plane**.

RADIATED EMISSION TEST (ABOVE 1GHz):

Pre-Scan has been conducted to determine the worst-case mode from all possible combinations between available modulations, data rates and antenna ports (if EUT with antenna diversity architecture).

Following channel(s) was (were) selected for the final test as listed below.

EUT CONFIGURE MODE	MODE	AVAILABLE CHANNEL	TESTED CHANNEL	MODULATION TECHNOLOGY	MODULATION TYPE	DATA RATE (Mbps)
-	802.11b	1 to 11	1, 6, 11	DSSS	DBPSK	1.0
-	802.11g	1 to 11	1, 6, 11	OFDM	BPSK	6.0
-	802.11n (20MHz)	1 to 11	1, 6, 11	OFDM	BPSK	MCS0

RADIATED EMISSION TEST (BELOW 1GHz):

Pre-Scan has been conducted to determine the worst-case mode from all possible combinations between available modulations, data rates and antenna ports (if EUT with antenna diversity architecture).

Following channel(s) was (were) selected for the final test as listed below.

EUT CONFIGURE MODE	MODE	AVAILABLE CHANNEL	TESTED CHANNEL	MODULATION TECHNOLOGY	MODULATION TYPE	DATA RATE (Mbps)
-	802.11n (20MHz)	1 to 11	11	OFDM	BPSK	MCS0

POWER LINE CONDUCTED EMISSION TEST:

EUT CONFIGURE MODE	MODE	AVAILABLE CHANNEL	TESTED CHANNEL	MODULATION TECHNOLOGY	MODULATION TYPE	DATA RATE (Mbps)
-	802.11n (20MHz)	1 to 11	11	OFDM	BPSK	MCS0



BANDEDGE MEASUREMENT:

- Pre-Scan has been conducted to determine the worst-case mode from all possible combinations between available modulations, data rates and antenna ports (if EUT with antenna diversity architecture).
- Following channel(s) was (were) selected for the final test as listed below.

EUT CONFIGURE MODE	MODE	AVAILABLE CHANNEL	TESTED CHANNEL	MODULATION TECHNOLOGY	MODULATION TYPE	DATA RATE (Mbps)
-	802.11b	1 to 11	1, 6, 11	DSSS	DBPSK	1.0
-	802.11g	1 to 11	1, 6, 11	OFDM	BPSK	6.0
-	802.11n (20MHz)	1 to 11	1, 6, 11	OFDM	BPSK	MCS0

ANTENNA PORT CONDUCTED MEASUREMENT:

- This item includes all test value of each mode, but only includes spectrum plot of worst value of each mode.
- Pre-Scan has been conducted to determine the worst-case mode from all possible combinations between available modulations, data rates and antenna ports (if EUT with antenna diversity architecture).
- Following channel(s) was (were) selected for the final test as listed below.

EUT CONFIGURE MODE	MODE	AVAILABLE CHANNEL	TESTED CHANNEL	MODULATION TECHNOLOGY	MODULATION TYPE	DATA RATE (Mbps)
-	802.11b	1 to 11	1, 6, 11	DSSS	DBPSK	1.0
-	802.11g	1 to 11	1, 6, 11	OFDM	BPSK	6.0
-	802.11n (20MHz)	1 to 11	1, 6, 11	OFDM	BPSK	MCS0

Test CONDITION:

APPLICABLE TO	ENVIRONMENTAL CONDITIONS	INPUT POWER	TESTED BY
RE≥1G	25deg. C, 65%RH	120Vac, 60Hz	Harry Hsueh
RE<1G	25deg. C, 65%RH	120Vac, 60Hz	Harry Hsueh
PLC	25deg. C, 65%RH	120Vac, 60Hz	Peter Weng
APCM	25deg. C, 65%RH	120Vac, 60Hz	Howard Kao



A D T

WLAN 5.0GHz (5745 ~ 5825MHz):

EUT CONFIGURE MODE	APPLICABLE TO				DESCRIPTION
	RE≥1G	RE<1G	PLC	APCM	
-	√	√	√	√	-

Where **RE≥1G**: Radiated Emission above 1GHz **RE<1G**: Radiated Emission below 1GHz
PLC: Power Line Conducted Emission **APCM**: Antenna Port Conducted Measurement

NOTE: The EUT had been pre-tested on the positioned of each 3 axis. The worst case was found when positioned on **Z-plane**.

RADIATED EMISSION TEST (ABOVE 1GHz):

- Pre-Scan has been conducted to determine the worst-case mode from all possible combinations between available modulations, data rates and antenna ports (if EUT with antenna diversity architecture).
- Following channel(s) was (were) selected for the final test as listed below.

EUT CONFIGURE MODE	MODE	AVAILABLE CHANNEL	TESTED CHANNEL	MODULATION TECHNOLOGY	MODULATION TYPE	DATA RATE (Mbps)
-	802.11a	149 to 161	149, 157, 165	OFDM	BPSK	6.0
-	802.11n (20MHz)	149 to 161	149, 157, 165	OFDM	BPSK	MCS0
-	802.11n (40MHz)	151 to 159	151, 159	OFDM	BPSK	MCS0
-	802.11ac (80MHz)	155	155	OFDM	BPSK	V0

RADIATED EMISSION TEST (BELOW 1GHz):

- Pre-Scan has been conducted to determine the worst-case mode from all possible combinations between available modulations, data rates and antenna ports (if EUT with antenna diversity architecture).
- Following channel(s) was (were) selected for the final test as listed below.

EUT CONFIGURE MODE	MODE	AVAILABLE CHANNEL	TESTED CHANNEL	MODULATION TECHNOLOGY	MODULATION TYPE	DATA RATE (Mbps)
-	802.11ac (80MHz)	155	155	OFDM	BPSK	V0

POWER LINE CONDUCTED EMISSION TEST:

EUT CONFIGURE MODE	MODE	AVAILABLE CHANNEL	TESTED CHANNEL	MODULATION TECHNOLOGY	MODULATION TYPE	DATA RATE (Mbps)
-	802.11ac (80MHz)	155	155	OFDM	BPSK	V0



BANDEDGE MEASUREMENT:

Pre-Scan has been conducted to determine the worst-case mode from all possible combinations between available modulations, data rates and antenna ports (if EUT with antenna diversity architecture).

Following channel(s) was (were) selected for the final test as listed below.

EUT CONFIGURE MODE	MODE	AVAILABLE CHANNEL	TESTED CHANNEL	MODULATION TECHNOLOGY	MODULATION TYPE	DATA RATE (Mbps)
-	802.11a	149 to 161	149, 157, 165	OFDM	BPSK	6.0
-	802.11n (20MHz)	149 to 161	149, 157, 165	OFDM	BPSK	MCS0
-	802.11n (40MHz)	151 to 159	151, 159	OFDM	BPSK	MCS0
-	802.11ac (80MHz)	155	155	OFDM	BPSK	V0

ANTENNA PORT CONDUCTED MEASUREMENT:

Pre-Scan has been conducted to determine the worst-case mode from all possible combinations between available modulations, data rates and antenna ports (if EUT with antenna diversity architecture).

Following channel(s) was (were) selected for the final test as listed below.

EUT CONFIGURE MODE	MODE	AVAILABLE CHANNEL	TESTED CHANNEL	MODULATION TECHNOLOGY	MODULATION TYPE	DATA RATE (Mbps)
-	802.11a	149 to 161	149, 157, 165	OFDM	BPSK	6.0
-	802.11n (20MHz)	149 to 161	149, 157, 165	OFDM	BPSK	MCS0
-	802.11n (40MHz)	151 to 159	151, 159	OFDM	BPSK	MCS0
-	802.11ac (80MHz)	155	155	OFDM	BPSK	V0

Test CONDITION:

APPLICABLE TO	ENVIRONMENTAL CONDITIONS	INPUT POWER	TESTED BY
RE≥1G	25deg. C, 65%RH	120Vac, 60Hz	Harry Hsueh
RE<1G	25deg. C, 65%RH	120Vac, 60Hz	Harry Hsueh
PLC	25deg. C, 65%RH	120Vac, 60Hz	Peter Weng
APCM	25deg. C, 65%RH	120Vac, 60Hz	Howard Kao

3.3 DESCRIPTION OF SUPPORT UNITS

The EUT has been tested as an independent unit together with other necessary accessories or support units. The following support units or accessories were used to form a representative test configuration during the tests.

NO.	PRODUCT	BRAND	MODEL NO.	SERIAL NO.	FCC ID
1	Earphone	N/A	N/A	N/A	N/A

NO.	SIGNAL CABLE DESCRIPTION OF THE ABOVE SUPPORT UNITS
1	N/A

NOTE:

1. All power cords of the above support units are non shielded (1.8m).

3.3.1 CONFIGURATION OF SYSTEM UNDER TEST

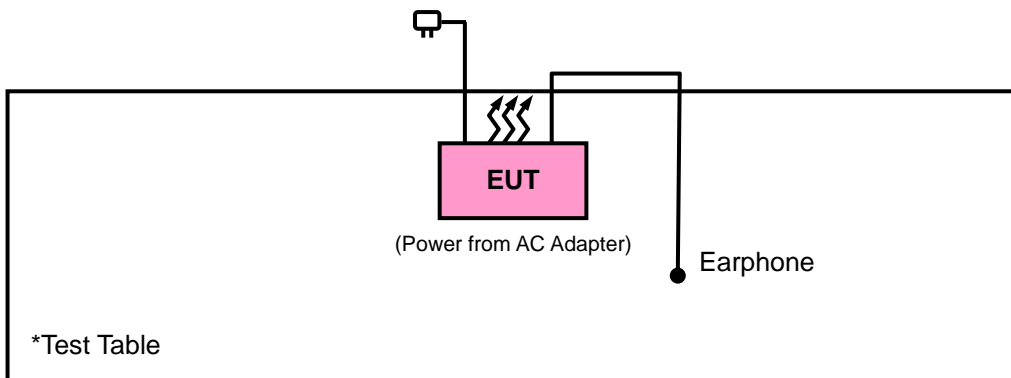



A D T

3.4 DUTY CYCLE TEST SIGNAL

WLAN 2.4GHz

If duty cycle is < 98%, duty factor shall be considered.

802.11b: Duty cycle = $12.243/12.756 = 0.96$, Duty factor = $10 * \log(1/0.96) = 0.18$

802.11g: Duty cycle = $2.037/2.534 = 0.804$, Duty factor = $10 * \log(1/0.804) = 0.95$

802.11n (20MHz): Duty cycle = $1.9/2.413 = 0.787$, Duty factor = $10 * \log(1/0.787) = 1.04$

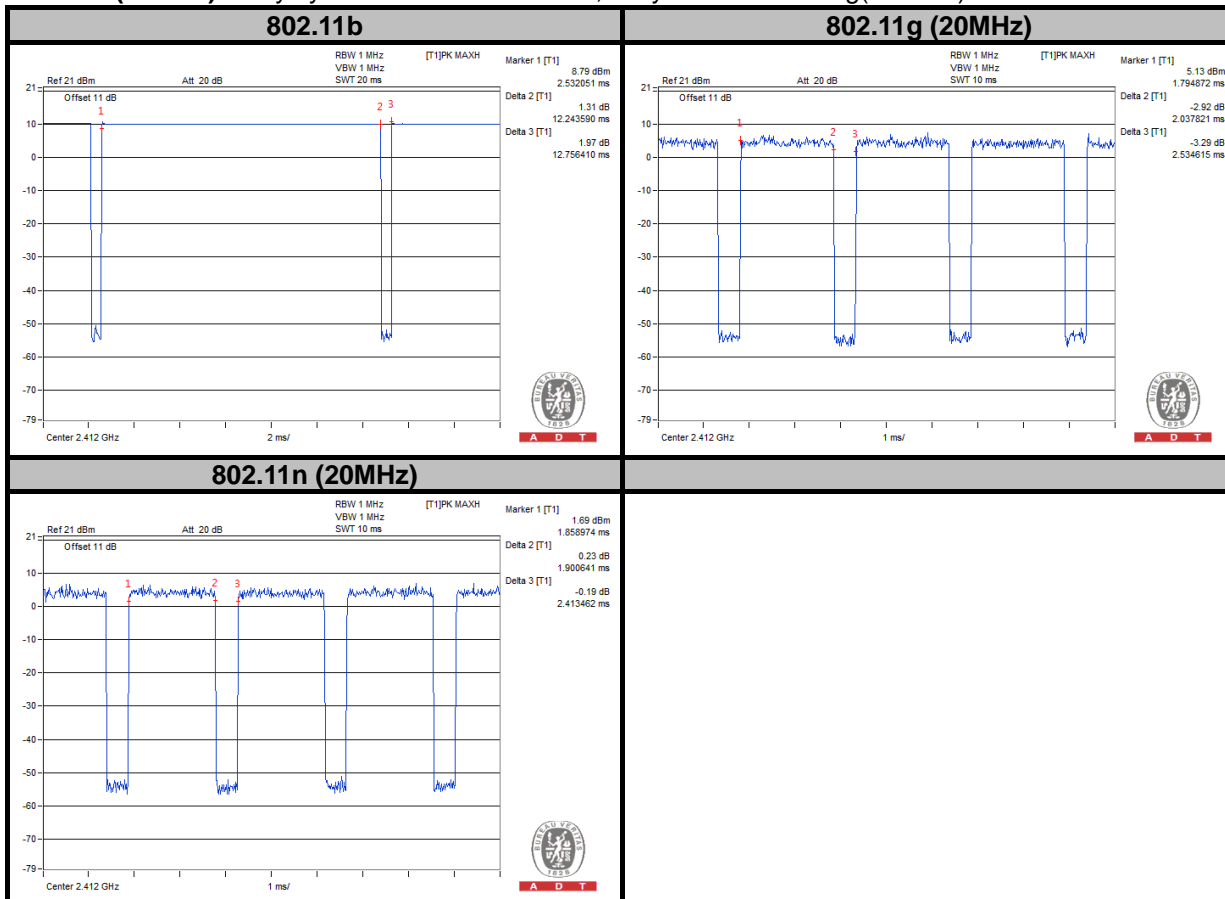

5745MHz ~ 5825MHz

If duty cycle is < 98%, duty factor shall be considered.

802.11a: Duty cycle = $1.987/2.532 = 0.785$, Duty factor = $10 * \log(1/0.785) = 1.05$

802.11n (20MHz): Duty cycle = $1.887/2.416 = 0.781$, Duty factor = $10 * \log(1/0.781) = 1.07$

802.11n (40MHz): Duty cycle = $0.906/1.443 = 0.628$, Duty factor = $10 * \log(1/0.628) = 2.02$

802.11ac (80MHz): Duty cycle = $0.217/0.75 = 0.289$, Duty factor = $10 * \log(1/0.289) = 5.39$

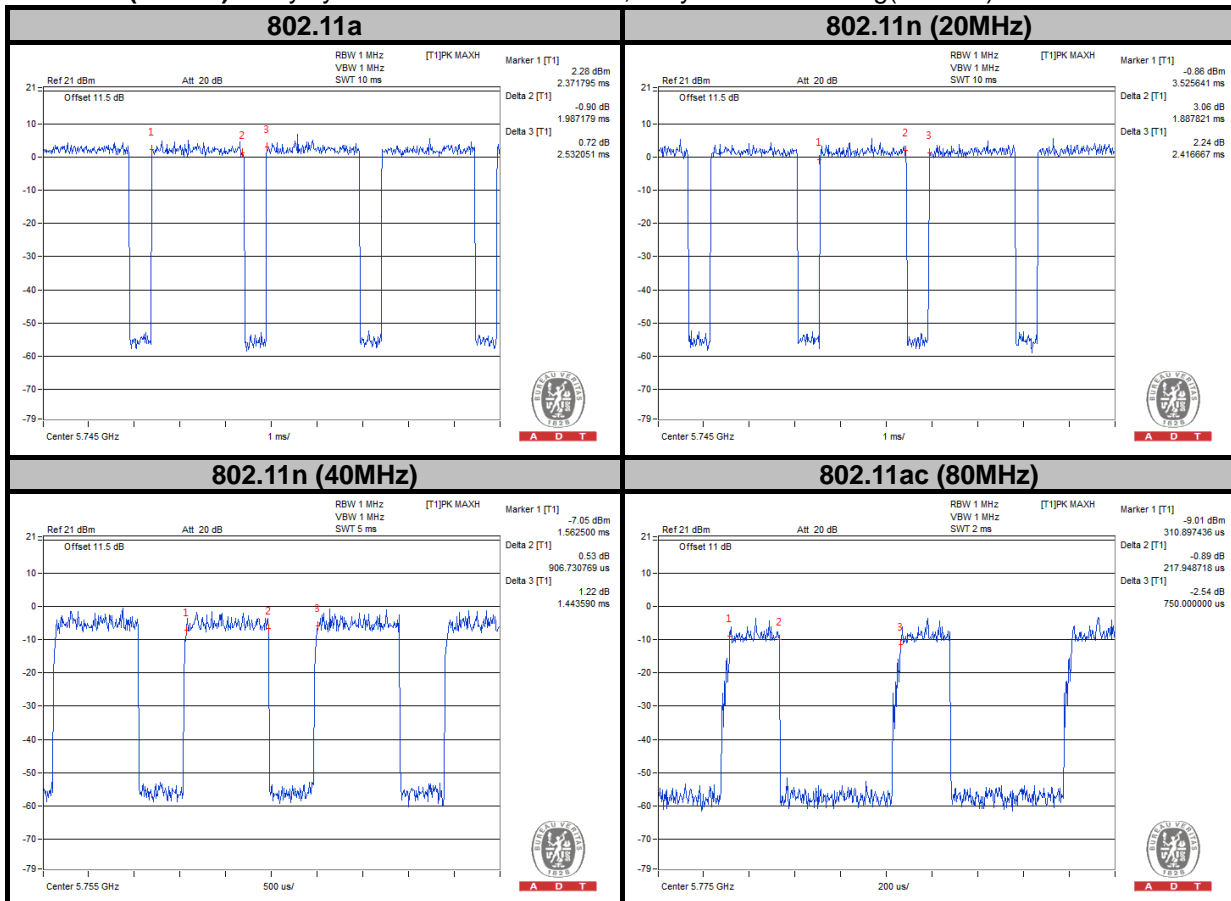

3.5 GENERAL DESCRIPTION OF APPLIED STANDARDS

The EUT is a RF Product. According to the specifications of the manufacturer, it must comply with the requirements of the following standards:

FCC Part 15, Subpart C (15.247)

ANSI C63.10-2009

558074 D01 DTS Meas Guidance v03r01

All test items have been performed and recorded as per the above standards.

4. TEST TYPES AND RESULTS (FOR 2.4GHz BAND)

4.1 RADIATED EMISSION AND BANDEDGE MEASUREMENT

4.1.1 LIMITS OF RADIATED EMISSION AND BANDEDGE MEASUREMENT

Radiated emissions which fall in the restricted bands must comply with the radiated emission limits specified as below table. Other emissions shall be at least 20dB below the highest level of the desired power:

FREQUENCIES (MHz)	FIELD STRENGTH (microvolts/meter)	MEASUREMENT DISTANCE (meters)
0.009 ~ 0.490	2400/F(kHz)	300
0.490 ~ 1.705	24000/F(kHz)	30
1.705 ~ 30.0	30	30
30 ~ 88	100	3
88 ~ 216	150	3
216 ~ 960	200	3
Above 960	500	3

NOTE:

1. The lower limit shall apply at the transition frequencies.
2. Emission level (dBuV/m) = 20 log Emission level (uV/m).
3. For frequencies above 1000MHz, the field strength limits are based on average detector, however, the peak field strength of any emission shall not exceed the maximum permitted average limits, specified above by more than 20dB under any condition of modulation.



4.1.2 TEST INSTRUMENTS

DESCRIPTION & MANUFACTURER	MODEL NO.	SERIAL NO.	DATE OF CALIBRATION	DUE DATE OF CALIBRATION
Test Receiver ROHDE & SCHWARZ	ESCI	100744	Apr. 15, 2013	Apr. 14, 2014
Spectrum Analyzer ROHDE & SCHWARZ	FSU43	101261	Dec. 21, 2013	Dec. 20, 2014
BILOG Antenna SCHWARZBECK	VULB9168	9168-472	Mar. 25, 2013	Mar. 24, 2014
HORN Antenna SCHWARZBECK	BBHA 9120 D	9120D- 209	Sep. 12, 2013	Sep. 11, 2014
HORN Antenna SCHWARZBECK	BBHA 9170	9170-480	Dec. 18, 2013	Dec. 17, 2014
Loop Antenna	3127-836	00099258	Aug. 09, 2013	Aug. 08, 2014
Preamplifier EMCI	EMC 012645	980115	Dec. 26, 2013	Dec. 25, 2014
Preamplifier EMCI	EMC 184045	980116	Jan. 13, 2014	Jan. 12, 2015
Preamplifier EMCI	EMC 330H	980112	Dec. 27, 2013	Dec. 26, 2014
RF signal cable HUBER+SUHNNER	SUCOFLEX 104	309219/4	Oct. 18, 2013	Oct. 17, 2014
RF signal cable HUBER+SUHNNER	SUCOFLEX 104	250130/4	Oct. 18, 2013	Oct. 17, 2014
RF signal cable Worken	RG-213	NA	Nov. 07, 2013	Nov. 06, 2014
Software BV ADT	E3 6.120103	NA	NA	NA
Antenna Tower MF	MFA-440H	NA	NA	NA
Turn Table MF	MFT-201SS	NA	NA	NA
Antenna Tower & Turn Table Controller MF	MF-7802	NA	NA	NA
Power Meter	ML2495A	1232002	Aug. 23, 2013	Aug. 22, 2014
Power Sensor	MA2411B	1207325	Aug. 23, 2013	Aug. 22, 2014

- NOTE:**
1. The calibration interval of the above test instruments is 12 months and the calibrations are traceable to NML/ROC and NIST/USA.
 2. The calibration interval of the loop antenna is 24 months and the calibrations are traceable to NML/ROC and NIST/USA.
 3. The test was performed in HwaYa Chamber 10.
 4. The horn antenna and HP preamplifier (model: 8449B) are used only for the measurement of emission frequency above 1GHz if tested.
 5. The FCC Site Registration No. is 690701.
 6. The IC Site Registration No. is IC 7450F-10.

4.1.3 TEST PROCEDURES

- a. The EUT was placed on the top of a rotating table 0.8 meters above the ground at a 3 meters semi-anechoic chamber. The table was rotated 360 degrees to determine the position of the highest radiation.
- b. The EUT was set 3 meters away from the interference-receiving antenna, which was mounted on the top of a variable-height antenna tower.
- c. Height of receiving antenna is varied from one meter to four meters above the ground to determine the maximum value of the field strength. Both horizontal and vertical polarizations of the antenna are set to make the measurement.
- d. For each suspected emission, the EUT was arranged to its worst case and then the antenna was tuned to heights from 1 meter to 4 meters and the rotatable table was turned from 0 degrees to 360 degrees to find the maximum reading.
- e. The test-receiver system was set to Peak Detect Function and Specified Bandwidth with Maximum Hold Mode.
- f. If the emission level of the EUT in peak mode was lower than the limit specified, then testing could be stopped and the peak values of the EUT would be reported. Otherwise the emissions would be re-tested one by one using peak, quasi-peak or average method as specified and then reported in a data sheet.

NOTE:

1. The resolution bandwidth and video bandwidth of test receiver/spectrum analyzer is 120kHz for Quasi-peak detection at frequency below 1GHz.
2. The resolution bandwidth of test receiver/spectrum analyzer is 1MHz and video bandwidth is 3MHz for Peak detection at frequency above 1GHz.
3. The resolution bandwidth of test receiver/spectrum analyzer is 1MHz and the video bandwidth is 1kHz (Duty cycle < 98%) or 10Hz (Duty cycle > 98%) for Average detection (AV) at frequency above 1GHz.
4. All modes of operation were investigated and the worst-case emissions are reported.

4.1.4 DEVIATION FROM TEST STANDARD

No deviation.

4.1.5 TEST SETUP

Frequency Range 30MHz ~ 1GHz

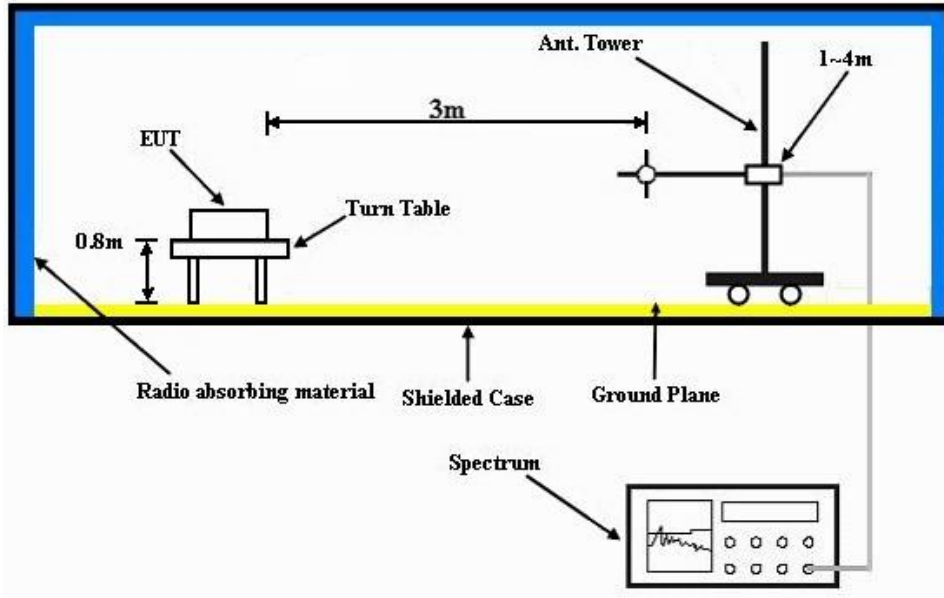

Frequency Range above 1GHz

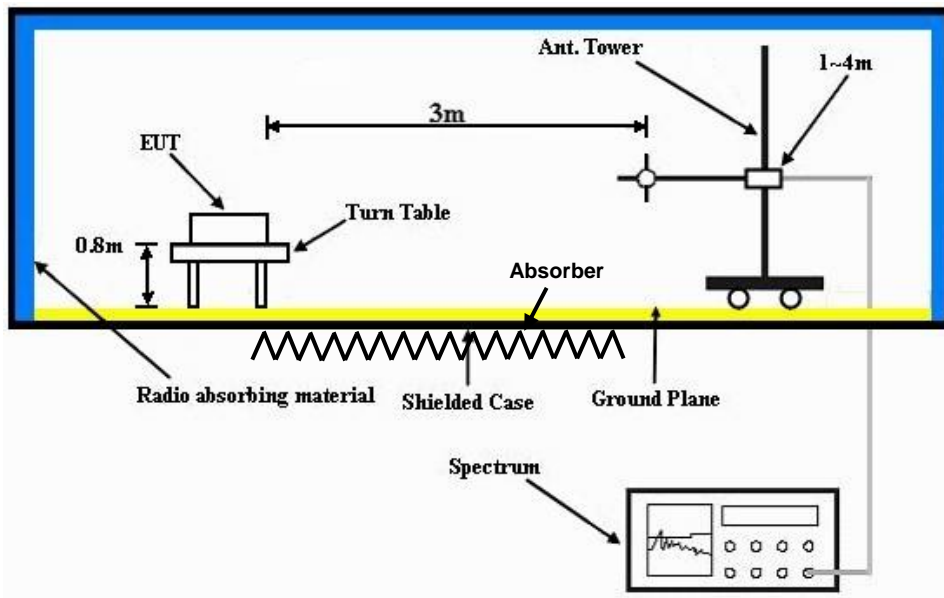

For the actual test configuration, please refer to the attached file (Test Setup Photo).

4.1.6 EUT OPERATING CONDITIONS

- a. Placed the EUT on a testing table.
- b. Use the software to control the EUT under transmission condition continuously at specific channel frequency.



A D T

4.1.7 TEST RESULTS

ABOVE 1GHz WORST-CASE DATA

802.11b

EUT TEST CONDITION		MEASUREMENT DETAIL	
CHANNEL	Channel 1	FREQUENCY RANGE	1GHz ~ 25GHz
INPUT POWER	120Vac, 60 Hz	DETECTOR FUNCTION	Peak (PK) Average (AV)
ENVIRONMENTAL CONDITIONS	25deg. C, 65%RH	TESTED BY	Harry Hsueh

ANTENNA POLARITY & TEST DISTANCE: HORIZONTAL AT 3 M

FREQ. (MHz)	EMISSION LEVEL (dBuV/m)	READ LEVEL (dBuV)	LIMIT (dBuV/m)	MARGIN (dB)	ANTENNA FACTOR (dB/m)	CABLE LOSS (dB)	PREAMP FACTOR (dB)	ANTENNA HEIGHT (cm)	TABLE ANGLE (Degree)	REMARK
2388	43.78	42.07	54	-10.22	31.8	5.4	35.49	135	303	Average
2388	56.25	54.54	74	-17.75	31.8	5.4	35.49	135	303	Peak
2412	104.03	102.26			31.81	5.43	35.47	135	303	Average
2412	107.19	105.42			31.81	5.43	35.47	135	303	Peak
2490	41	38.99	54	-13	31.9	5.53	35.42	135	303	Average
2490	55.6	53.59	74	-18.4	31.9	5.53	35.42	135	303	Peak

ANTENNA POLARITY & TEST DISTANCE: VERTICAL AT 3 M

FREQ. (MHz)	EMISSION LEVEL (dBuV/m)	READ LEVEL (dBuV)	LIMIT (dBuV/m)	MARGIN (dB)	ANTENNA FACTOR (dB/m)	CABLE LOSS (dB)	PREAMP FACTOR (dB)	ANTENNA HEIGHT (cm)	TABLE ANGLE (Degree)	REMARK
2352	40.65	39.06	54	-13.35	31.76	5.33	35.5	117	25	Average
2352	55.69	54.1	74	-18.31	31.76	5.33	35.5	117	25	Peak
2412	101.83	100.06			31.81	5.43	35.47	117	25	Average
2412	103.27	101.5			31.81	5.43	35.47	117	25	Peak
2492	41	38.98	54	-13	31.9	5.53	35.41	117	25	Average
2492	54.62	52.6	74	-19.38	31.9	5.53	35.41	117	25	Peak

REMARKS:

- Emission Level = Read Level + Antenna Factor + Cable Loss - Preamp Factor
Margin value = Emission level – Limit value
- 2412MHz: Fundamental frequency.



A D T

EUT TEST CONDITION		MEASUREMENT DETAIL	
CHANNEL	Channel 6	FREQUENCY RANGE	1GHz ~ 25GHz
INPUT POWER	120Vac, 60 Hz	DETECTOR FUNCTION	Peak (PK) Average (AV)
ENVIRONMENTAL CONDITIONS	25deg. C, 65%RH	TESTED BY	Harry Hsueh

ANTENNA POLARITY & TEST DISTANCE: HORIZONTAL AT 3 M

FREQ. (MHz)	EMISSION LEVEL (dBuV/m)	READ LEVEL (dBuV)	LIMIT (dBuV/m)	MARGIN (dB)	ANTENNA FACTOR (dB/m)	CABLE LOSS (dB)	PREAMP FACTOR (dB)	ANTENNA HEIGHT (cm)	TABLE ANGLE (Degree)	REMARK
2342	40.65	39.08	54	-13.35	31.74	5.33	35.5	101	305	Average
2342	56.02	54.45	74	-17.98	31.74	5.33	35.5	101	305	Peak
2437	104.9	103.05			31.85	5.46	35.46	101	305	Average
2437	107.56	105.71			31.85	5.46	35.46	101	305	Peak
2500	41.12	39.1	54	-12.88	31.9	5.53	35.41	101	305	Average
2500	55.88	53.86	74	-18.12	31.9	5.53	35.41	101	305	Peak

ANTENNA POLARITY & TEST DISTANCE: VERTICAL AT 3 M

FREQ. (MHz)	EMISSION LEVEL (dBuV/m)	READ LEVEL (dBuV)	LIMIT (dBuV/m)	MARGIN (dB)	ANTENNA FACTOR (dB/m)	CABLE LOSS (dB)	PREAMP FACTOR (dB)	ANTENNA HEIGHT (cm)	TABLE ANGLE (Degree)	REMARK
2370	40.67	39.01	54	-13.33	31.78	5.37	35.49	113	25	Average
2370	55.11	53.45	74	-18.89	31.78	5.37	35.49	113	25	Peak
2437	101.9	100.05			31.85	5.46	35.46	113	25	Average
2437	103.79	101.94			31.85	5.46	35.46	113	25	Peak
2484	40.95	38.99	54	-13.05	31.88	5.5	35.42	113	25	Average
2484	55.55	53.59	74	-18.45	31.88	5.5	35.42	113	25	Peak

REMARKS:

- Emission Level = Read Level + Antenna Factor + Cable Loss - Preamp Factor
Margin value = Emission level – Limit value
- 2437MHz: Fundamental frequency.



A D T

EUT TEST CONDITION		MEASUREMENT DETAIL	
CHANNEL	Channel 11	FREQUENCY RANGE	1GHz ~ 25GHz
INPUT POWER	120Vac, 60 Hz	DETECTOR FUNCTION	Peak (PK) Average (AV)
ENVIRONMENTAL CONDITIONS	25deg. C, 65%RH	TESTED BY	Harry Hsueh

ANTENNA POLARITY & TEST DISTANCE: HORIZONTAL AT 3 M

FREQ. (MHz)	EMISSION LEVEL (dBuV/m)	READ LEVEL (dBuV)	LIMIT (dBuV/m)	MARGIN (dB)	ANTENNA FACTOR (dB/m)	CABLE LOSS (dB)	PREAMP FACTOR (dB)	ANTENNA HEIGHT (cm)	TABLE ANGLE (Degree)	REMARK
2364	40.68	39.05	54	-13.32	31.76	5.37	35.5	100	304	Average
2364	55.5	53.87	74	-18.5	31.76	5.37	35.5	100	304	Peak
2462	105.22	103.29			31.87	5.5	35.44	100	304	Average
2462	107.09	105.16			31.87	5.5	35.44	100	304	Peak
2488	44.02	42.01	54	-9.98	31.9	5.53	35.42	100	304	Average
2488	55.72	53.71	74	-18.28	31.9	5.53	35.42	100	304	Peak

ANTENNA POLARITY & TEST DISTANCE: VERTICAL AT 3 M

FREQ. (MHz)	EMISSION LEVEL (dBuV/m)	READ LEVEL (dBuV)	LIMIT (dBuV/m)	MARGIN (dB)	ANTENNA FACTOR (dB/m)	CABLE LOSS (dB)	PREAMP FACTOR (dB)	ANTENNA HEIGHT (cm)	TABLE ANGLE (Degree)	REMARK
2312	40.35	38.87	54	-13.65	31.71	5.3	35.53	111	28	Average
2312	55.8	54.32	74	-18.2	31.71	5.3	35.53	111	28	Peak
2462	101	99.07			31.87	5.5	35.44	111	28	Average
2462	103.6	101.67			31.87	5.5	35.44	111	28	Peak
2490	44.01	42	54	-9.99	31.9	5.53	35.42	111	28	Average
2490	56.34	54.33	74	-17.66	31.9	5.53	35.42	111	28	Peak

REMARKS:

- Emission Level = Read Level + Antenna Factor + Cable Loss - Preamp Factor
Margin value = Emission level – Limit value
- 2462MHz: Fundamental frequency.



A D T

802.11g

EUT TEST CONDITION		MEASUREMENT DETAIL	
CHANNEL	Channel 1	FREQUENCY RANGE	1GHz ~ 25GHz
INPUT POWER	120Vac, 60 Hz	DETECTOR FUNCTION	Peak (PK) Average (AV)
ENVIRONMENTAL CONDITIONS	25deg. C, 65%RH	TESTED BY	Harry Hsueh

ANTENNA POLARITY & TEST DISTANCE: HORIZONTAL AT 3 M

FREQ. (MHz)	EMISSION LEVEL (dBuV/m)	READ LEVEL (dBuV)	LIMIT (dBuV/m)	MARGIN (dB)	ANTENNA FACTOR (dB/m)	CABLE LOSS (dB)	PREAMP FACTOR (dB)	ANTENNA HEIGHT (cm)	TABLE ANGLE (Degree)	REMARK
2390	50.3	48.57	54	-3.7	31.8	5.4	35.47	138	302	Average
2390	62.74	61.01	74	-11.26	31.8	5.4	35.47	138	302	Peak
2412	96.21	94.44			31.81	5.43	35.47	138	302	Average
2412	104.49	102.72			31.81	5.43	35.47	138	302	Peak
2488	40.96	38.95	54	-13.04	31.9	5.53	35.42	138	302	Average
2488	55.25	53.24	74	-18.75	31.9	5.53	35.42	138	302	Peak

ANTENNA POLARITY & TEST DISTANCE: VERTICAL AT 3 M

FREQ. (MHz)	EMISSION LEVEL (dBuV/m)	READ LEVEL (dBuV)	LIMIT (dBuV/m)	MARGIN (dB)	ANTENNA FACTOR (dB/m)	CABLE LOSS (dB)	PREAMP FACTOR (dB)	ANTENNA HEIGHT (cm)	TABLE ANGLE (Degree)	REMARK
2390	48.79	47.06	54	-5.21	31.8	5.4	35.47	117	11	Average
2390	62.95	61.22	74	-11.05	31.8	5.4	35.47	117	11	Peak
2412	94.81	93.04			31.81	5.43	35.47	117	11	Average
2412	102.99	101.22			31.81	5.43	35.47	117	11	Peak
2490	39.99	37.98	54	-14.01	31.9	5.53	35.42	117	11	Average
2490	56.83	54.82	74	-17.17	31.9	5.53	35.42	117	11	Peak

REMARKS:

- Emission Level = Read Level + Antenna Factor + Cable Loss - Preamp Factor
Margin value = Emission level – Limit value
- 2412MHz: Fundamental frequency.



A D T

EUT TEST CONDITION		MEASUREMENT DETAIL	
CHANNEL	Channel 6	FREQUENCY RANGE	1GHz ~ 25GHz
INPUT POWER	120Vac, 60 Hz	DETECTOR FUNCTION	Peak (PK) Average (AV)
ENVIRONMENTAL CONDITIONS	25deg. C, 65%RH	TESTED BY	Harry Hsueh

ANTENNA POLARITY & TEST DISTANCE: HORIZONTAL AT 3 M

FREQ. (MHz)	EMISSION LEVEL (dBuV/m)	READ LEVEL (dBuV)	LIMIT (dBuV/m)	MARGIN (dB)	ANTENNA FACTOR (dB/m)	CABLE LOSS (dB)	PREAMP FACTOR (dB)	ANTENNA HEIGHT (cm)	TABLE ANGLE (Degree)	REMARK
2312	40.68	39.2	54	-13.32	31.71	5.3	35.53	132	302	Average
2312	54.88	53.4	74	-19.12	31.71	5.3	35.53	132	302	Peak
2437	97.67	95.82			31.85	5.46	35.46	132	302	Average
2437	105.98	104.13			31.85	5.46	35.46	132	302	Peak
2490	41.29	39.28	54	-12.71	31.9	5.53	35.42	132	302	Average
2490	56.99	54.98	74	-17.01	31.9	5.53	35.42	132	302	Peak

ANTENNA POLARITY & TEST DISTANCE: VERTICAL AT 3 M

FREQ. (MHz)	EMISSION LEVEL (dBuV/m)	READ LEVEL (dBuV)	LIMIT (dBuV/m)	MARGIN (dB)	ANTENNA FACTOR (dB/m)	CABLE LOSS (dB)	PREAMP FACTOR (dB)	ANTENNA HEIGHT (cm)	TABLE ANGLE (Degree)	REMARK
2358	40.65	39.02	54	-13.35	31.76	5.37	35.5	114	17	Average
2358	55.03	53.4	74	-18.97	31.76	5.37	35.5	114	17	Peak
2437	94.21	92.36			31.85	5.46	35.46	114	17	Average
2437	102.18	100.33			31.85	5.46	35.46	114	17	Peak
2486	40.98	38.99	54	-13.02	31.88	5.53	35.42	114	17	Average
2486	56.78	54.79	74	-17.22	31.88	5.53	35.42	114	17	Peak

REMARKS:

- Emission Level = Read Level + Antenna Factor + Cable Loss - Preamp Factor
Margin value = Emission level – Limit value
- 2437MHz: Fundamental frequency.



A D T

EUT TEST CONDITION		MEASUREMENT DETAIL	
CHANNEL	Channel 11	FREQUENCY RANGE	1GHz ~ 25GHz
INPUT POWER	120Vac, 60 Hz	DETECTOR FUNCTION	Peak (PK) Average (AV)
ENVIRONMENTAL CONDITIONS	25deg. C, 65%RH	TESTED BY	Harry Hsueh

ANTENNA POLARITY & TEST DISTANCE: HORIZONTAL AT 3 M

FREQ. (MHz)	EMISSION LEVEL (dBuV/m)	READ LEVEL (dBuV)	LIMIT (dBuV/m)	MARGIN (dB)	ANTENNA FACTOR (dB/m)	CABLE LOSS (dB)	PREAMP FACTOR (dB)	ANTENNA HEIGHT (cm)	TABLE ANGLE (Degree)	REMARK
2372	40.67	39.01	54	-13.33	31.78	5.37	35.49	100	309	Average
2372	55.9	54.24	74	-18.1	31.78	5.37	35.49	100	309	Peak
2462	97.26	95.33			31.87	5.5	35.44	100	309	Average
2462	105.2	103.27			31.87	5.5	35.44	100	309	Peak
2483.5	51.71	49.75	54	-2.29	31.88	5.5	35.42	100	309	Average
2483.5	66.06	64.1	74	-7.94	31.88	5.5	35.42	100	309	Peak

ANTENNA POLARITY & TEST DISTANCE: VERTICAL AT 3 M

FREQ. (MHz)	EMISSION LEVEL (dBuV/m)	READ LEVEL (dBuV)	LIMIT (dBuV/m)	MARGIN (dB)	ANTENNA FACTOR (dB/m)	CABLE LOSS (dB)	PREAMP FACTOR (dB)	ANTENNA HEIGHT (cm)	TABLE ANGLE (Degree)	REMARK
2374	40.67	39.01	54	-13.33	31.78	5.37	35.49	112	25	Average
2374	56.21	54.55	74	-17.79	31.78	5.37	35.49	112	25	Peak
2462	95.66	93.73			31.87	5.5	35.44	112	25	Average
2462	102.97	101.04			31.87	5.5	35.44	112	25	Peak
2483.5	50.33	48.37	54	-3.67	31.88	5.5	35.42	112	25	Average
2483.5	64.6	62.64	74	-9.4	31.88	5.5	35.42	112	25	Peak

REMARKS:

- Emission Level = Read Level + Antenna Factor + Cable Loss - Preamp Factor
Margin value = Emission level – Limit value
- 2462MHz: Fundamental frequency.



A D T

802.11n (20MHz)

EUT TEST CONDITION		MEASUREMENT DETAIL	
CHANNEL	Channel 1	FREQUENCY RANGE	1GHz ~ 25GHz
INPUT POWER	120Vac, 60 Hz	DETECTOR FUNCTION	Peak (PK) Average (AV)
ENVIRONMENTAL CONDITIONS	25deg. C, 65%RH	TESTED BY	Harry Hsueh

ANTENNA POLARITY & TEST DISTANCE: HORIZONTAL AT 3 M

FREQ. (MHz)	EMISSION LEVEL (dBuV/m)	READ LEVEL (dBuV)	LIMIT (dBuV/m)	MARGIN (dB)	ANTENNA FACTOR (dB/m)	CABLE LOSS (dB)	PREAMP FACTOR (dB)	ANTENNA HEIGHT (cm)	TABLE ANGLE (Degree)	REMARK
2390	48.72	46.99	54	-5.28	31.8	5.4	35.47	131	303	Average
2390	62.24	60.51	74	-11.76	31.8	5.4	35.47	131	303	Peak
2412	96.01	94.24			31.81	5.43	35.47	131	303	Average
2412	104.19	102.42			31.81	5.43	35.47	131	303	Peak
2500	41	38.98	54	-13	31.9	5.53	35.41	131	303	Average
2500	55.26	53.24	74	-18.74	31.9	5.53	35.41	131	303	Peak

ANTENNA POLARITY & TEST DISTANCE: VERTICAL AT 3 M

FREQ. (MHz)	EMISSION LEVEL (dBuV/m)	READ LEVEL (dBuV)	LIMIT (dBuV/m)	MARGIN (dB)	ANTENNA FACTOR (dB/m)	CABLE LOSS (dB)	PREAMP FACTOR (dB)	ANTENNA HEIGHT (cm)	TABLE ANGLE (Degree)	REMARK
2388	47.55	45.84	54	-6.45	31.8	5.4	35.49	117	10	Average
2388	59.15	57.44	74	-14.85	31.8	5.4	35.49	117	10	Peak
2412	93.81	92.04			31.81	5.43	35.47	117	10	Average
2412	101.89	100.12			31.81	5.43	35.47	117	10	Peak
2484	40.95	38.99	54	-13.05	31.88	5.5	35.42	117	10	Average
2484	55.2	53.24	74	-18.8	31.88	5.5	35.42	117	10	Peak

REMARKS:

- Emission Level = Read Level + Antenna Factor + Cable Loss - Preamp Factor
Margin value = Emission level – Limit value
- 2412MHz: Fundamental frequency.



A D T

EUT TEST CONDITION		MEASUREMENT DETAIL	
CHANNEL	Channel 6	FREQUENCY RANGE	1GHz ~ 25GHz
INPUT POWER	120Vac, 60 Hz	DETECTOR FUNCTION	Peak (PK) Average (AV)
ENVIRONMENTAL CONDITIONS	25deg. C, 65%RH	TESTED BY	Harry Hsueh

ANTENNA POLARITY & TEST DISTANCE: HORIZONTAL AT 3 M

FREQ. (MHz)	EMISSION LEVEL (dBuV/m)	READ LEVEL (dBuV)	LIMIT (dBuV/m)	MARGIN (dB)	ANTENNA FACTOR (dB/m)	CABLE LOSS (dB)	PREAMP FACTOR (dB)	ANTENNA HEIGHT (cm)	TABLE ANGLE (Degree)	REMARK
2386	43.72	42.01	54	-10.28	31.8	5.4	35.49	135	303	Average
2386	57.07	55.36	74	-16.93	31.8	5.4	35.49	135	303	Peak
2437	97.7	95.85			31.85	5.46	35.46	135	303	Average
2437	105.55	103.7			31.85	5.46	35.46	135	303	Peak
2488	44	41.99	54	-10	31.9	5.53	35.42	135	303	Average
2488	56.54	54.53	74	-17.46	31.9	5.53	35.42	135	303	Peak

ANTENNA POLARITY & TEST DISTANCE: VERTICAL AT 3 M

FREQ. (MHz)	EMISSION LEVEL (dBuV/m)	READ LEVEL (dBuV)	LIMIT (dBuV/m)	MARGIN (dB)	ANTENNA FACTOR (dB/m)	CABLE LOSS (dB)	PREAMP FACTOR (dB)	ANTENNA HEIGHT (cm)	TABLE ANGLE (Degree)	REMARK
2372	40.71	39.05	54	-13.29	31.78	5.37	35.49	111	25	Average
2372	56.58	54.92	74	-17.42	31.78	5.37	35.49	111	25	Peak
2437	94.48	92.63			31.85	5.46	35.46	111	25	Average
2437	102.76	100.91			31.85	5.46	35.46	111	25	Peak
2488	40.99	38.98	54	-13.01	31.9	5.53	35.42	111	25	Average
2488	55.8	53.79	74	-18.2	31.9	5.53	35.42	111	25	Peak

REMARKS:

- Emission Level = Read Level + Antenna Factor + Cable Loss - Preamp Factor
Margin value = Emission level – Limit value
- 2437MHz: Fundamental frequency.



A D T

EUT TEST CONDITION		MEASUREMENT DETAIL	
CHANNEL	Channel 11	FREQUENCY RANGE	1GHz ~ 25GHz
INPUT POWER	120Vac, 60 Hz	DETECTOR FUNCTION	Peak (PK) Average (AV)
ENVIRONMENTAL CONDITIONS	25deg. C, 65%RH	TESTED BY	Harry Hsueh

ANTENNA POLARITY & TEST DISTANCE: HORIZONTAL AT 3 M

FREQ. (MHz)	EMISSION LEVEL (dBuV/m)	READ LEVEL (dBuV)	LIMIT (dBuV/m)	MARGIN (dB)	ANTENNA FACTOR (dB/m)	CABLE LOSS (dB)	PREAMP FACTOR (dB)	ANTENNA HEIGHT (cm)	TABLE ANGLE (Degree)	REMARK
2360	40.65	39.02	54	-13.35	31.76	5.37	35.5	129	305	Average
2360	55.12	53.49	74	-18.88	31.76	5.37	35.5	129	305	Peak
2462	97.89	95.96			31.87	5.5	35.44	129	305	Average
2462	105.22	103.29			31.87	5.5	35.44	129	305	Peak
2483.5	53.51	51.55	54	-0.49	31.88	5.5	35.42	129	305	Average
2483.5	72.26	70.3	74	-1.74	31.88	5.5	35.42	129	305	Peak

ANTENNA POLARITY & TEST DISTANCE: VERTICAL AT 3 M

FREQ. (MHz)	EMISSION LEVEL (dBuV/m)	READ LEVEL (dBuV)	LIMIT (dBuV/m)	MARGIN (dB)	ANTENNA FACTOR (dB/m)	CABLE LOSS (dB)	PREAMP FACTOR (dB)	ANTENNA HEIGHT (cm)	TABLE ANGLE (Degree)	REMARK
2350	40.61	39.04	54	-13.39	31.74	5.33	35.5	111	25	Average
2350	54.12	52.55	74	-19.88	31.74	5.33	35.5	111	25	Peak
2462	95.49	93.56			31.87	5.5	35.44	111	25	Average
2462	103.69	101.76			31.87	5.5	35.44	111	25	Peak
2483.5	52.93	50.97	54	-1.07	31.88	5.5	35.42	111	25	Average
2483.5	67.58	65.62	74	-6.42	31.88	5.5	35.42	111	25	Peak

REMARKS:

- Emission Level = Read Level + Antenna Factor + Cable Loss - Preamp Factor
Margin value = Emission level – Limit value
- 2462MHz: Fundamental frequency.



A D T

BELOW 1GHz WORST-CASE DATA:

802.11n (20MHz)

EUT TEST CONDITION		MEASUREMENT DETAIL	
CHANNEL	Channel 11	FREQUENCY RANGE	30MHz ~ 1GHz
INPUT POWER	120Vac, 60 Hz	DETECTOR FUNCTION	Peak (PK) Average (AV)
ENVIRONMENTAL CONDITIONS	25deg. C, 65%RH	TESTED BY	Harry Hsueh

ANTENNA POLARITY & TEST DISTANCE: HORIZONTAL AT 3 M

FREQ. (MHz)	EMISSION LEVEL (dBuV/m)	READ LEVEL (dBuV)	LIMIT (dBuV/m)	MARGIN (dB)	ANTENNA FACTOR (dB/m)	CABLE LOSS (dB)	PREAMP FACTOR (dB)	ANTENNA HEIGHT (cm)	TABLE ANGLE (Degree)	REMARK
86.97	35.82	57.81	40	-4.18	8.76	1.11	31.86	165	215	Peak
143.67	30.69	51.97	43.5	-12.81	9.61	1.38	32.27	105	145	Peak
211.44	26.77	46.02	43.5	-16.73	11.35	1.65	32.25	188	102	Peak
367.9	27.18	40.72	46	-18.82	16.32	2.26	32.12	132	125	Peak
585.6	21.09	29.99	46	-24.91	20.48	2.82	32.2	156	215	Peak
694.8	24.71	30.55	46	-21.29	23.14	3.11	32.09	115	114	Peak

ANTENNA POLARITY & TEST DISTANCE: VERTICAL AT 3 M

FREQ. (MHz)	EMISSION LEVEL (dBuV/m)	READ LEVEL (dBuV)	LIMIT (dBuV/m)	MARGIN (dB)	ANTENNA FACTOR (dB/m)	CABLE LOSS (dB)	PREAMP FACTOR (dB)	ANTENNA HEIGHT (cm)	TABLE ANGLE (Degree)	REMARK
79.41	33.78	56.5	40	-6.22	8.38	1.11	32.21	103	102	Peak
143.67	26.79	48.07	43.5	-16.71	9.61	1.38	32.27	199	256	Peak
179.85	26.66	46.93	43.5	-16.84	10.36	1.61	32.24	156	231	Peak
349	25.57	39.14	46	-20.43	16.31	2.19	32.07	165	216	Peak
518.4	24.41	33.52	46	-21.59	20.32	2.7	32.13	145	124	Peak
657	23.46	30.08	46	-22.54	22.53	2.99	32.14	175	145	Peak

REMARKS: Emission Level = Read Level + Antenna Factor + Cable Loss - Preamp Factor

Margin value = Emission level – Limit value

4.2 CONDUCTED EMISSION MEASUREMENT

4.2.1 LIMITS OF CONDUCTED EMISSION MEASUREMENT

FREQUENCY OF EMISSION (MHz)	CONDUCTED LIMIT (dB μ V)	
	Quasi-peak	Average
0.15 ~ 0.5	66 to 56	56 to 46
0.5 ~ 5	56	46
5 ~ 30	60	50

- NOTE:**
1. The lower limit shall apply at the transition frequencies.
 2. The limit decreases in line with the logarithm of the frequency in the range of 0.15 to 0.50MHz.
 3. All emanations from a class A/B digital device or system, including any network of conductors and apparatus connected thereto, shall not exceed the level of field strengths specified above.

4.2.2 TEST INSTRUMENTS

DESCRIPTION & MANUFACTURER	MODEL NO.	SERIAL NO.	DATE OF CALIBRATION	DUE DATE OF CALIBRATION
Test Receiver ROHDE & SCHWARZ	ESCS30	100288	Nov. 17, 2013	Nov. 16, 2014
RF signal cable Woken	5D-FB	Cable-HYCO2-01	Dec. 27, 2013	Dec. 26, 2014
LISN ROHDE & SCHWARZ (EUT)	ESH2-Z5	100100	Dec. 23, 2013	Dec. 22, 2014
LISN ROHDE & SCHWARZ (Peripheral)	ESH3-Z5	100311	Jul. 17, 2013	Jul. 16, 2014
Software ADT	BV ADT_Cond_ V7.3.7.3	NA	NA	NA

- NOTE:**
1. The calibration interval of the above test instruments is 12 months and the calibrations are traceable to NML/ROC and NIST/USA.
 2. The test was performed in HwaYa Shielded Room 2.
 3. The VCCI Site Registration No. is C-2047.

4.2.3 TEST PROCEDURES

- a. The EUT was placed 0.4 meters from the conducting wall of the shielded room with EUT being connected to the power mains through a line impedance stabilization network (LISN). Other support units were connected to the power mains through another LISN. The two LISNs provide 50 ohm/ 50uH of coupling impedance for the measuring instrument.
- b. Both lines of the power mains connected to the EUT were checked for maximum conducted interference.
- c. The frequency range from 150kHz to 30MHz was searched. Emission levels under (Limit - 20dB) was not recorded.

NOTE: All modes of operation were investigated and the worst-case emissions are reported.

4.2.4 DEVIATION FROM TEST STANDARD

No deviation.

4.2.5 TEST SETUP

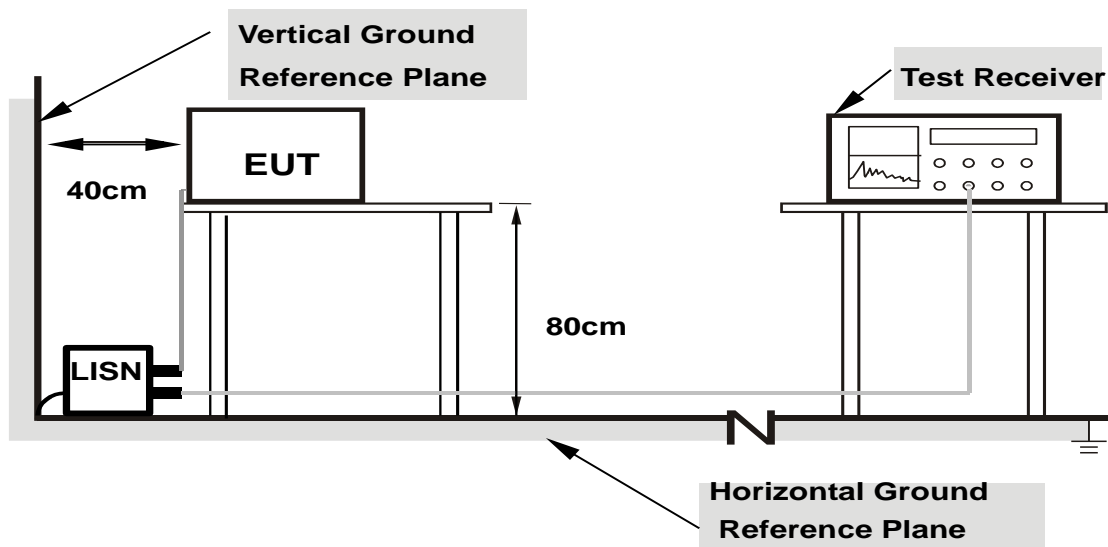

- Note:**
- 1.Support units were connected to second LISN.
 - 2.Both of LISNs (AMN) are 80 cm from EUT and at least 80 from other units and other metal planes

For the actual test configuration, please refer to the attached file (Test Setup Photo).

4.2.6 EUT OPERATING CONDITIONS

Same as section 4.1.6.

4.2.7 TEST RESULTS

CONDUCTED WORST-CASE DATA :

PHASE	Line 1	6dB BANDWIDTH	9kHz
-------	--------	---------------	------

No	Freq. [MHz]	Corr. Factor (dB)	Reading Value [dB (uV)]		Emission Level [dB (uV)]		Limit [dB (uV)]		Margin (dB)	
			Q.P.	AV.	Q.P.	AV.	Q.P.	AV.	Q.P.	AV.
	1	0.16562	0.27	46.95	31.28	47.22	31.55	65.18	55.18	-17.96
2	0.47813	0.31	34.58	30.11	34.89	30.42	56.37	46.37	-21.49	-15.96
3	1.14453	0.34	33.00	23.54	33.34	23.88	56.00	46.00	-22.66	-22.12
4	1.98438	0.36	35.80	25.55	36.16	25.91	56.00	46.00	-19.84	-20.09
5	13.55859	0.52	52.22	48.26	52.74	48.78	60.00	50.00	-7.26	-1.22
6	22.40234	0.56	35.76	28.21	36.32	28.77	60.00	50.00	-23.68	-21.23

REMARKS:

1. Q.P. and AV. are abbreviations of quasi-peak and average individually.
2. The emission levels of other frequencies were very low against the limit.
3. Margin value = Emission level - Limit value
4. Correction factor = Insertion loss + Cable loss
5. Emission Level = Correction Factor + Reading Value

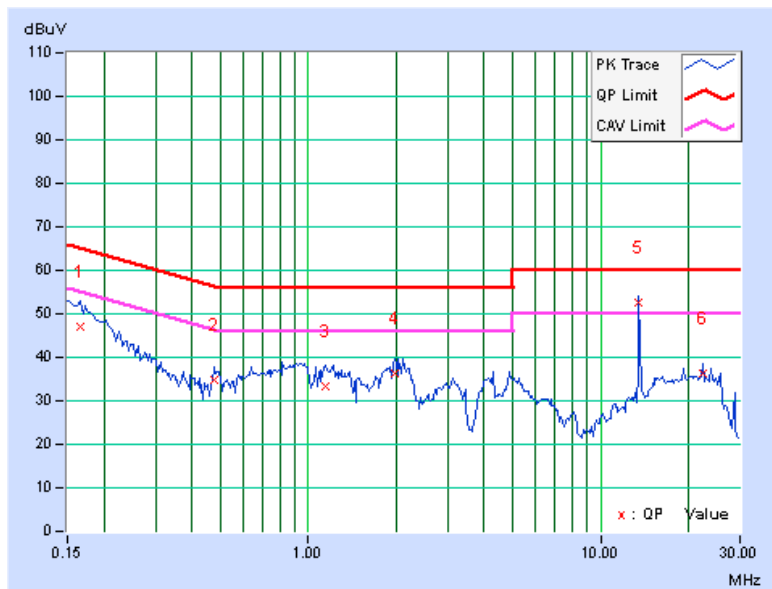

PHASE	Line 2	6dB BANDWIDTH	9kHz
-------	--------	---------------	------

No	Freq. [MHz]	Corr. Factor (dB)	Reading Value [dB (uV)]		Emission Level [dB (uV)]		Limit [dB (uV)]		Margin (dB)	
			Q.P.	AV.	Q.P.	AV.	Q.P.	AV.	Q.P.	AV.
			1	0.16562	0.27	48.36	31.30	48.63	31.57	65.18
2	0.47031	0.30	35.47	27.27	35.77	27.57	56.51	46.51	-20.73	-18.93
3	2.03516	0.37	29.69	20.28	30.06	20.65	56.00	46.00	-25.94	-25.35
4	4.08203	0.44	24.68	15.58	25.12	16.02	56.00	46.00	-30.88	-29.98
5	13.56250	0.55	46.66	41.88	47.21	42.43	60.00	50.00	-12.79	-7.57
6	25.60547	0.55	25.89	18.74	26.44	19.29	60.00	50.00	-33.56	-30.71

REMARKS:

1. Q.P. and AV. are abbreviations of quasi-peak and average individually.
2. The emission levels of other frequencies were very low against the limit.
3. Margin value = Emission level - Limit value
4. Correction factor = Insertion loss + Cable loss
5. Emission Level = Correction Factor + Reading Value

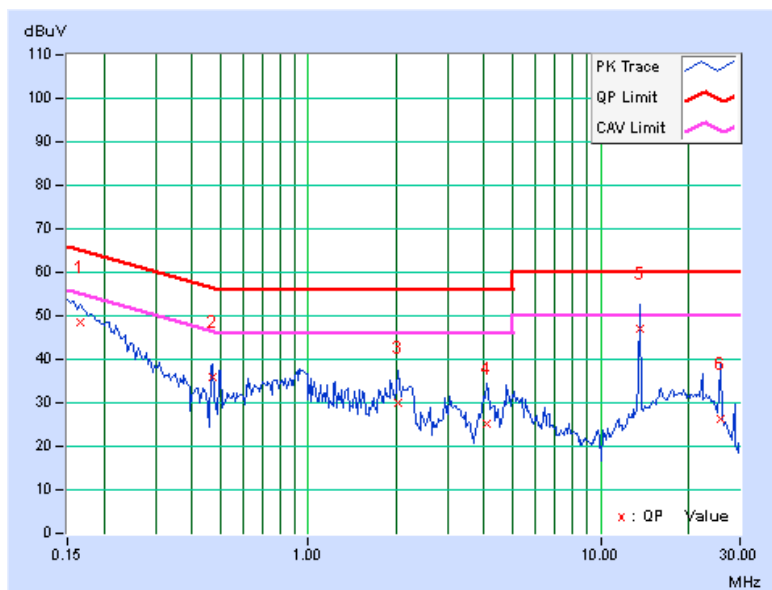

4.3 6dB BANDWIDTH MEASUREMENT

4.3.1 LIMITS OF 6dB BANDWIDTH MEASUREMENT

The minimum of 6dB Bandwidth Measurement is 0.5 MHz.

4.3.2 TEST SETUP

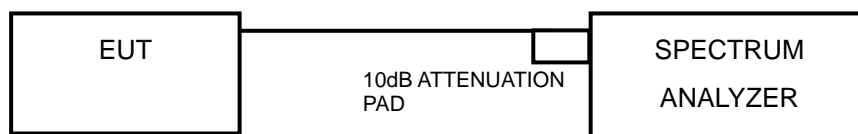

4.3.3 TEST INSTRUMENTS

Refer to section 4.1.2 to get information of above instrument.

4.3.4 TEST PROCEDURE

- Set resolution bandwidth (RBW) = 100kHz
- Set the video bandwidth (VBW) $\geq 3 \times$ RBW, Detector = Peak.
- Trace mode = max hold.
- Sweep = auto couple.
- Measure the maximum width of the emission that is constrained by the frequencies associated with the two amplitude points (upper and lower) that are attenuated by 6 dB relative to the maximum level measured in the fundamental emission

4.3.5 DEVIATION FROM TEST STANDARD

No deviation.

4.3.6 EUT OPERATING CONDITIONS

The software provided by client to enable the EUT under transmission condition continuously at lowest, middle and highest channel frequencies individually.



A D T

4.3.7 TEST RESULTS

802.11b

CHANNEL	FREQUENCY (MHz)	6dB BANDWIDTH (MHz)	MINIMUM LIMIT (MHz)	PASS / FAIL
1	2412	8.57	0.5	PASS
6	2437	9.01	0.5	PASS
11	2462	8.58	0.5	PASS

802.11g

CHANNEL	FREQUENCY (MHz)	6dB BANDWIDTH (MHz)	MINIMUM LIMIT (MHz)	PASS / FAIL
1	2412	16.38	0.5	PASS
6	2437	16.40	0.5	PASS
11	2462	16.38	0.5	PASS

802.11n (20MHz)

CHANNEL	FREQUENCY (MHz)	6dB BANDWIDTH (MHz)	MINIMUM LIMIT (MHz)	PASS / FAIL
1	2412	17.60	0.5	PASS
6	2437	17.63	0.5	PASS
11	2462	17.65	0.5	PASS



A D T

SPECTRUM PLOT OF WORST VALUE

802.11b

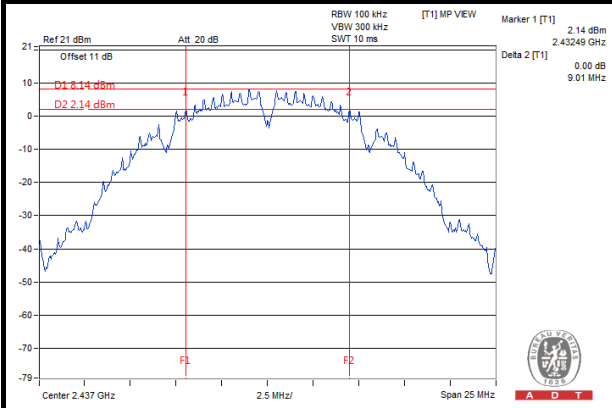

802.11g

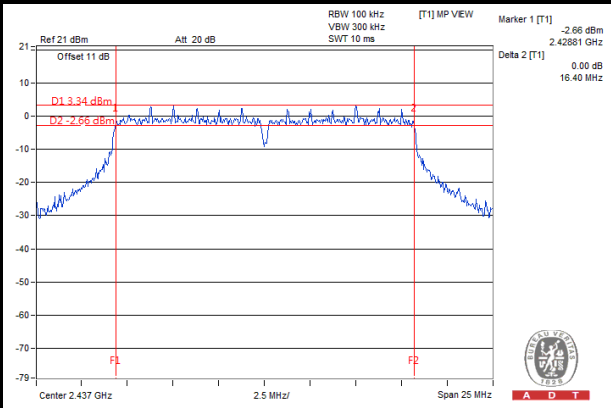

802.11n (20MHz)

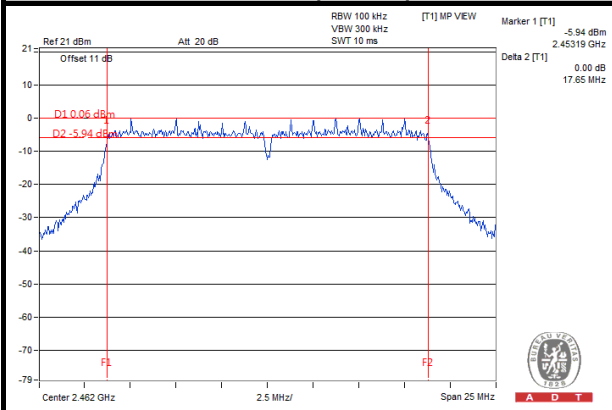

4.4 CONDUCTED OUTPUT POWER

4.4.1 LIMITS OF CONDUCTED OUTPUT POWER MEASUREMENT

For systems using digital modulation in the 2400–2483.5 MHz bands: 1 Watt (30dBm)

4.4.2 TEST SETUP

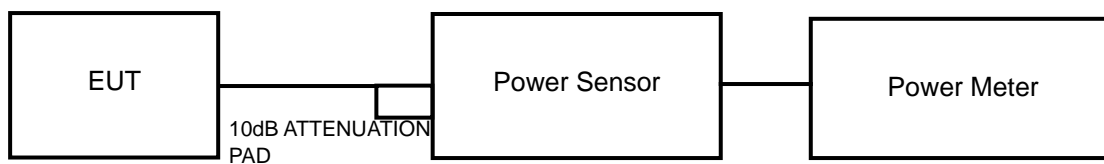

4.4.3 TEST INSTRUMENTS

Refer to section 4.1.2 to get information of above instrument.

4.4.4 TEST PROCEDURES

A peak power sensor was used on the output port of the EUT. A power meter was used to read the response of the peak power sensor. Record the peak power level.

4.4.5 DEVIATION FROM TEST STANDARD

No deviation.

4.4.6 EUT OPERATING CONDITIONS

Same as section 4.3.6.



A D T

4.4.7 TEST RESULTS

802.11b

CHANNEL	FREQUENCY (MHz)	PEAK POWER (mW)	PEAK POWER (dBm)	LIMIT (dBm)	PASS / FAIL
1	2412	78.524	18.95	30	PASS
6	2437	71.779	18.56	30	PASS
11	2462	74.645	18.73	30	PASS

802.11g

CHANNEL	FREQUENCY (MHz)	PEAK POWER (mW)	PEAK POWER (dBm)	LIMIT (dBm)	PASS / FAIL
1	2412	114.288	20.58	30	PASS
6	2437	148.936	21.73	30	PASS
11	2462	114.551	20.59	30	PASS

802.11n (20MHz)

CHANNEL	FREQUENCY (MHz)	PEAK POWER (mW)	PEAK POWER (dBm)	LIMIT (dBm)	PASS / FAIL
1	2412	111.173	20.46	30	PASS
6	2437	152.757	21.84	30	PASS
11	2462	122.744	20.89	30	PASS

4.5 POWER SPECTRAL DENSITY MEASUREMENT

4.5.1 LIMITS OF POWER SPECTRAL DENSITY MEASUREMENT

The Maximum of Power Spectral Density Measurement is 8dBm.

4.5.2 TEST SETUP

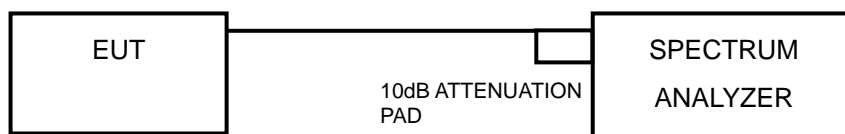

4.5.3 TEST INSTRUMENTS

Refer to section 4.1.2 to get information of above instrument.

4.5.4 TEST PROCEDURE

- Set the RBW = 3 kHz, VBW =10 kHz, Detector = peak.
- Sweep time = auto couple, Trace mode = max hold, allow trace to fully stabilize.
- Use the peak marker function to determine the maximum power level in any 100 kHz band segment within the fundamental EBW.

4.5.5 DEVIATION FROM TEST STANDARD

No deviation.

4.5.6 EUT OPERATING CONDITION

Same as section 4.3.6.



A D T

4.5.7 TEST RESULTS

802.11b

CHANNEL	FREQUENCY (MHz)	PSD (dBm/3kHz)	LIMIT (dBm/3kHz)	PASS / FAIL
1	2412	-5.92	8	PASS
6	2437	-6.36	8	PASS
11	2462	-7.20	8	PASS

802.11g

CHANNEL	FREQUENCY (MHz)	PSD (dBm/3kHz)	LIMIT (dBm/3kHz)	PASS / FAIL
1	2412	-12.42	8	PASS
6	2437	-11.83	8	PASS
11	2462	-11.96	8	PASS

802.11n (20MHz)

CHANNEL	FREQUENCY (MHz)	PSD (dBm/3kHz)	LIMIT (dBm/3kHz)	PASS / FAIL
1	2412	-13.13	8	PASS
6	2437	-11.78	8	PASS
11	2462	-14.60	8	PASS



A D T

SPECTRUM PLOT OF WORST VALUE

802.11b

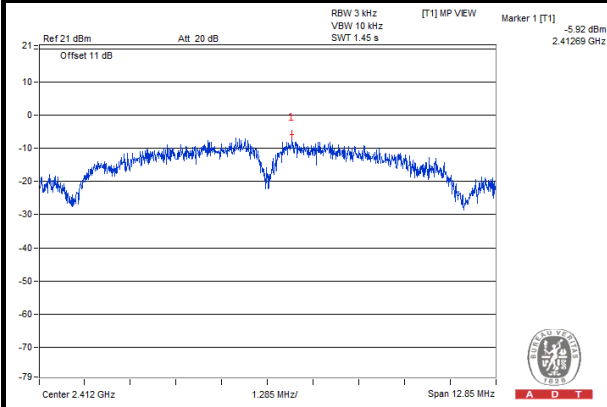

802.11g

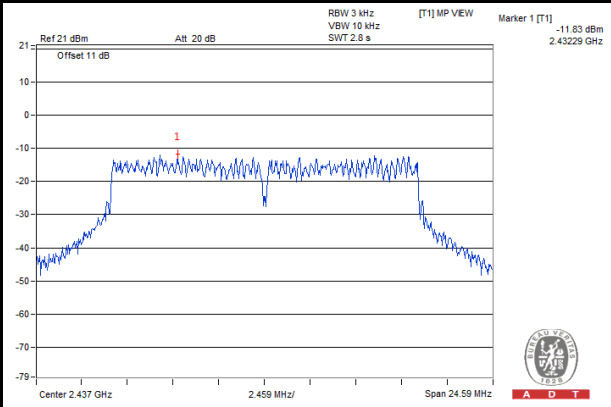

802.11n (20MHz)

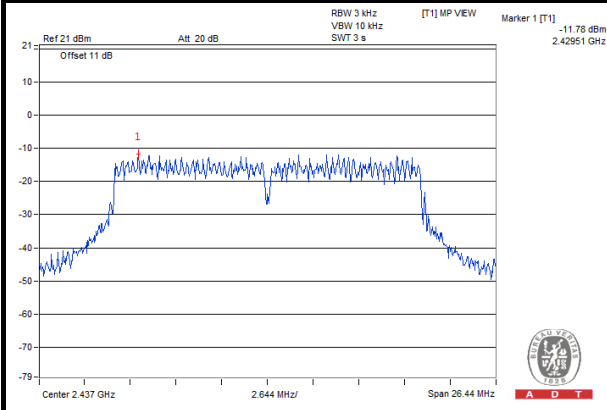

4.6 CONDUCTED OUT OF BAND EMISSION MEASUREMENT

4.6.1 LIMITS OF CONDUCTED OUT OF BAND EMISSION MEASUREMENT

Below -20dB of the highest emission level of operating band (in 100kHz Resolution Bandwidth).

4.6.2 TEST SETUP

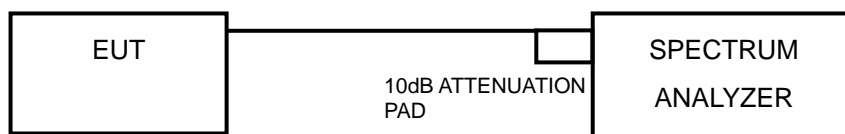

4.6.3 TEST INSTRUMENTS

Refer to section 4.1.2 to get information of above instrument.

4.6.4 TEST PROCEDURE

MEASUREMENT PROCEDURE REF

1. Set the RBW = 100 kHz.
2. Set the VBW \geq 300 kHz.
3. Detector = peak.
4. Sweep time = auto couple.
5. Trace mode = max hold.
6. Allow trace to fully stabilize.
7. Use the peak marker function to determine the maximum power level in any 100 kHz band segment within the fundamental EBW.

MEASUREMENT PROCEDURE OOB

1. Set RBW = 100 kHz.
2. Set VBW \geq 300 kHz.
3. Ensure that the number of measurement points \geq span/RBW
4. According to measurement points to set differ measurement span.
5. Detector = peak.
6. Trace Mode = max hold.
7. Sweep = auto couple.

4.6.5 DEVIATION FROM TEST STANDARD

No deviation.

4.6.6 EUT OPERATING CONDITION

Same as section 4.3.6.



A D T

4.6.7 TEST RESULTS

The spectrum plots are attached on the following images. D1 line indicates the highest level, and D2 line indicates the 20dB offset below D1. It shows compliance with the requirement.

802.11b

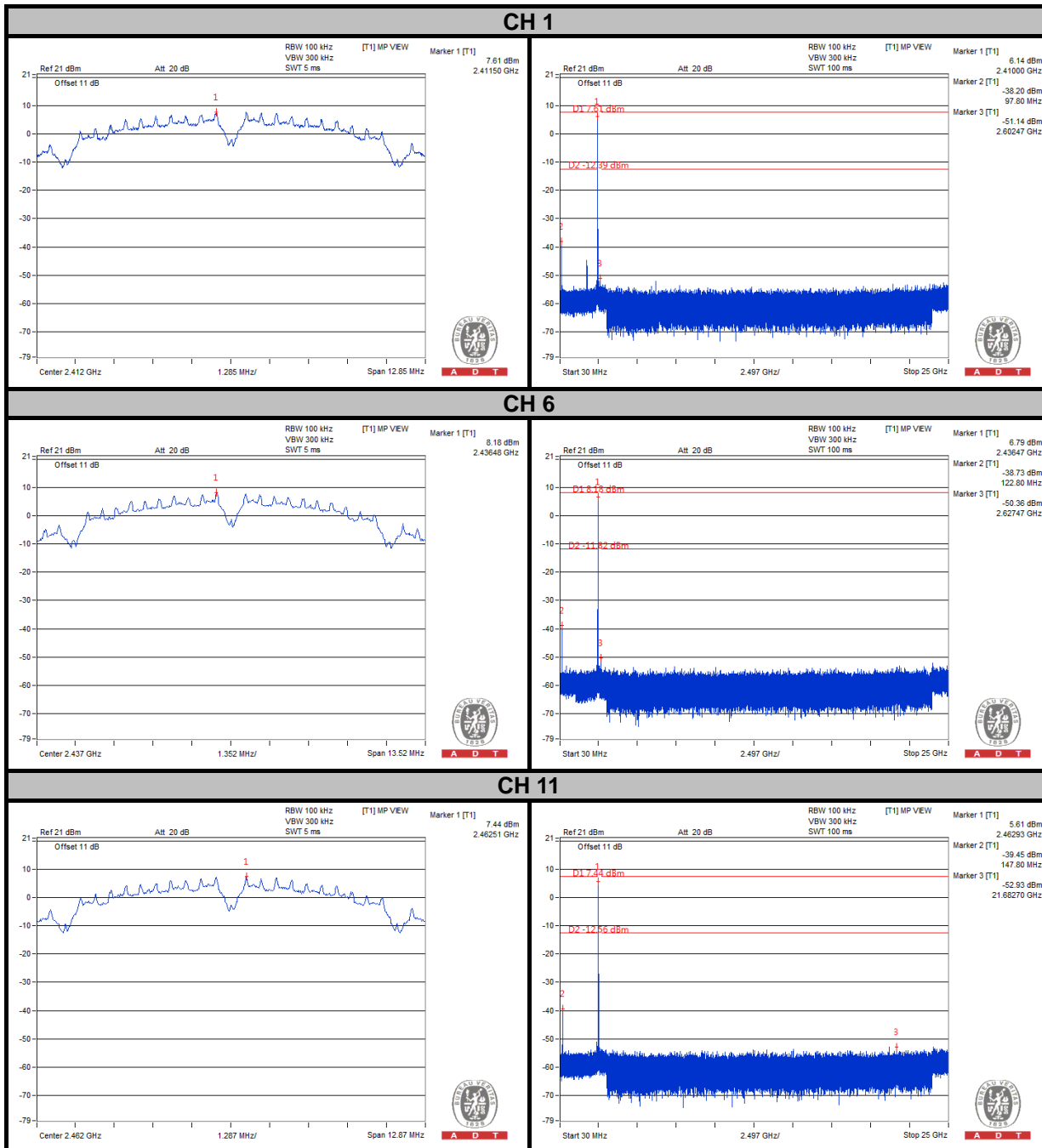



A D T

802.11g

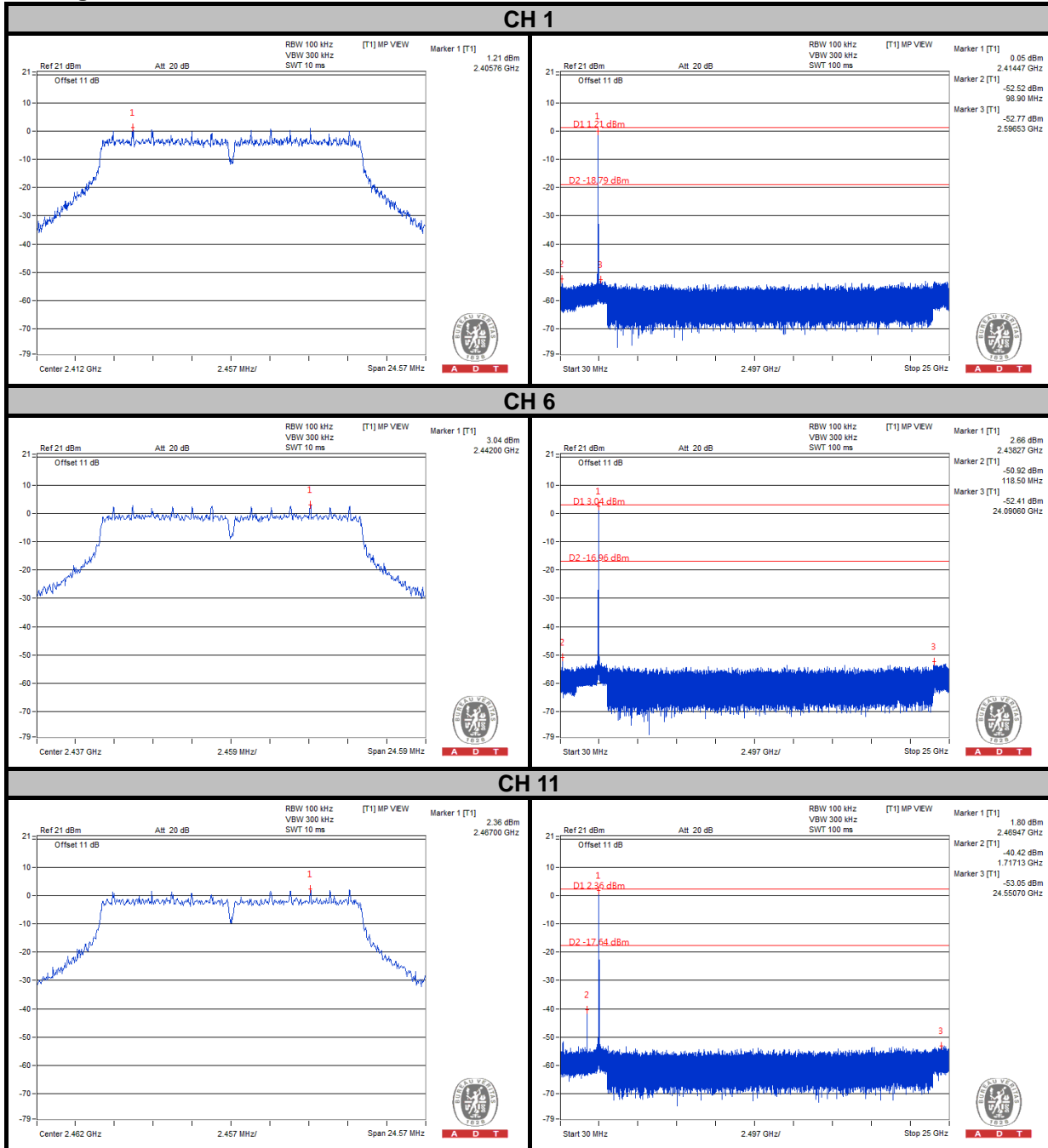



A D T

802.11n (20MHz)

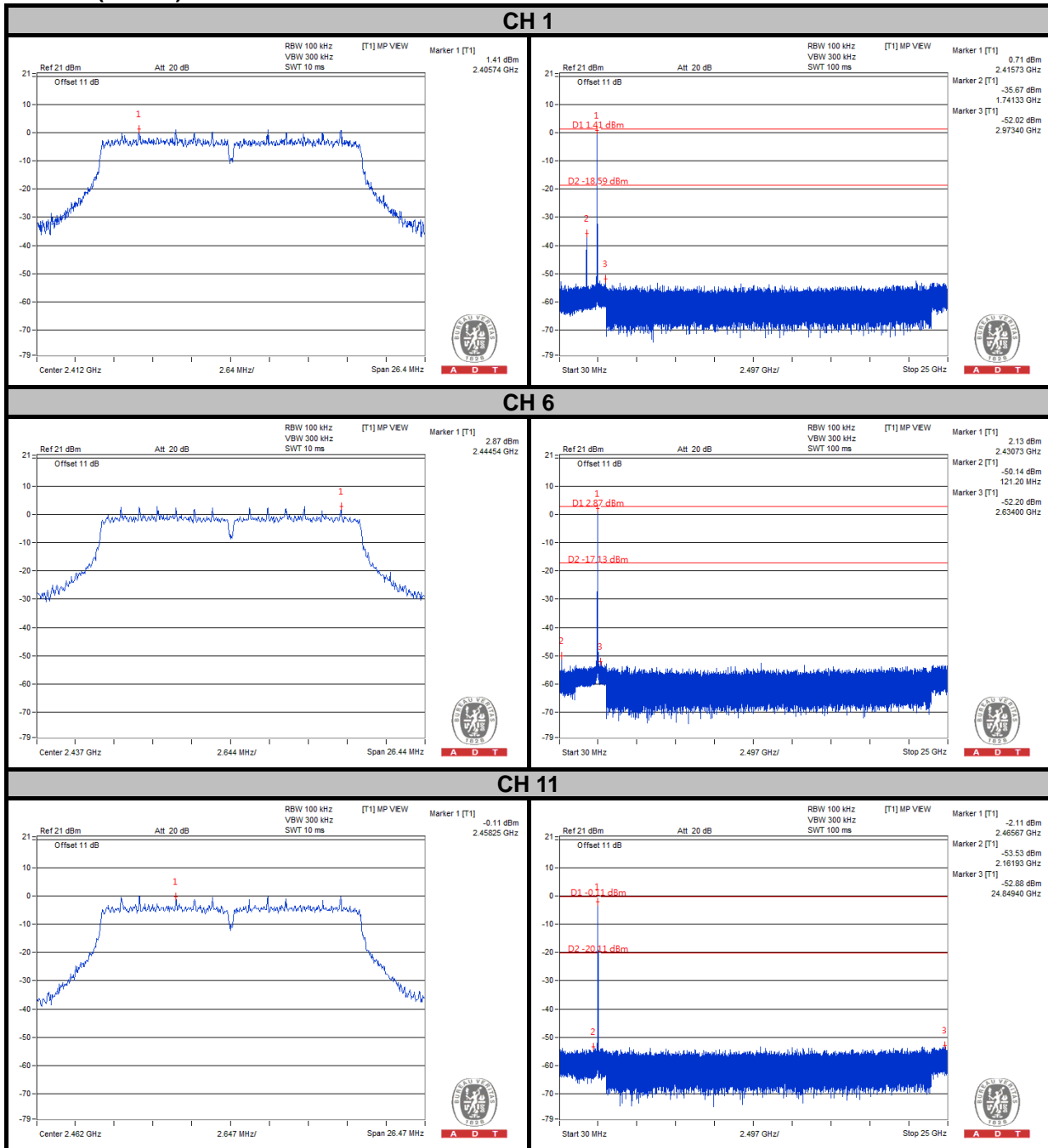

5. TEST TYPES AND RESULTS (FOR 5.0GHz BAND)

5.1 RADIATED EMISSION AND BANDEDGE MEASUREMENT

5.1.1 LIMITS OF RADIATED EMISSION AND BANDEDGE MEASUREMENT

Radiated emissions which fall in the restricted bands must comply with the radiated emission limits specified as below table. Other emissions shall be at least 20dB below the highest level of the desired power:

FREQUENCIES (MHz)	FIELD STRENGTH (microvolts/meter)	MEASUREMENT DISTANCE (meters)
0.009 ~ 0.490	2400/F(kHz)	300
0.490 ~ 1.705	24000/F(kHz)	30
1.705 ~ 30.0	30	30
30 ~ 88	100	3
88 ~ 216	150	3
216 ~ 960	200	3
Above 960	500	3

NOTE:

1. The lower limit shall apply at the transition frequencies.
2. Emission level (dBuV/m) = 20 log Emission level (uV/m).
3. For frequencies above 1000MHz, the field strength limits are based on average detector, however, the peak field strength of any emission shall not exceed the maximum permitted average limits, specified above by more than 20dB under any condition of modulation.



A D T

5.1.2 TEST INSTRUMENTS

Same as section 4.1.2.

5.1.3 TEST PROCEDURES

Same as section 4.1.3.

5.1.4 DEVIATION FROM TEST STANDARD

No deviation.

5.1.5 TEST SETUP

Same as section 4.1.5.

5.1.6 EUT OPERATING CONDITIONS

Same as section 4.1.6.



A D T

5.1.7 TEST RESULTS

ABOVE 1GHz WORST-CASE DATA :

802.11a

EUT TEST CONDITION		MEASUREMENT DETAIL	
CHANNEL	Channel 149	FREQUENCY RANGE	1GHz ~ 40GHz
INPUT POWER	120Vac, 60 Hz	DETECTOR FUNCTION	Peak (PK) Average (AV)
ENVIRONMENTAL CONDITIONS	25deg. C, 65%RH	TESTED BY	Harry Hsueh

ANTENNA POLARITY & TEST DISTANCE: HORIZONTAL AT 3 M

FREQ. (MHz)	EMISSION LEVEL (dBuV/m)	READ LEVEL (dBuV)	LIMIT (dBuV/m)	MARGIN (dB)	ANTENNA FACTOR (dB/m)	CABLE LOSS (dB)	PREAMP FACTOR (dB)	ANTENNA HEIGHT (cm)	TABLE ANGLE (Degree)	REMARK
5725	48.8	39.64	75.99	-27.19	34.62	8.65	34.11	102	296	Average
5725	60.18	51.02	83.36	-23.18	34.62	8.65	34.11	102	296	Peak
5745	95.99	86.8			34.64	8.66	34.11	102	296	Average
5745	103.36	94.17			34.64	8.66	34.11	102	296	Peak
5850	46.97	37.67	75.99	-29.02	34.74	8.7	34.14	102	296	Average
5850	58.82	49.52	83.36	-24.54	34.74	8.7	34.14	102	296	Peak

ANTENNA POLARITY & TEST DISTANCE: VERTICAL AT 3 M

FREQ. (MHz)	EMISSION LEVEL (dBuV/m)	READ LEVEL (dBuV)	LIMIT (dBuV/m)	MARGIN (dB)	ANTENNA FACTOR (dB/m)	CABLE LOSS (dB)	PREAMP FACTOR (dB)	ANTENNA HEIGHT (cm)	TABLE ANGLE (Degree)	REMARK
5725	49.8	40.64	77.95	-28.15	34.62	8.65	34.11	101	307	Average
5725	61.33	52.17	85.08	-23.75	34.62	8.65	34.11	101	307	Peak
5745	97.95	88.76			34.64	8.66	34.11	101	307	Average
5745	105.08	95.89			34.64	8.66	34.11	101	307	Peak
5850	47	37.7	77.95	-30.95	34.74	8.7	34.14	101	307	Average
5850	58.85	49.55	85.08	-26.23	34.74	8.7	34.14	101	307	Peak

REMARKS:

- Emission Level = Read Level + Antenna Factor + Cable Loss - Preamp Factor
Margin value = Emission level – Limit value
- 5745MHz: Fundamental frequency.
- 5725MHz & 5850MHz: Out of restricted band



A D T

EUT TEST CONDITION		MEASUREMENT DETAIL	
CHANNEL	Channel 157	FREQUENCY RANGE	1GHz ~ 40GHz
INPUT POWER	120Vac, 60 Hz	DETECTOR FUNCTION	Peak (PK) Average (AV)
ENVIRONMENTAL CONDITIONS	25deg. C, 65%RH	TESTED BY	Harry Hsueh

ANTENNA POLARITY & TEST DISTANCE: HORIZONTAL AT 3 M										
FREQ. (MHz)	EMISSION LEVEL (dBuV/m)	READ LEVEL (dBuV)	LIMIT (dBuV/m)	MARGIN (dB)	ANTENNA FACTOR (dB/m)	CABLE LOSS (dB)	PREAMP FACTOR (dB)	ANTENNA HEIGHT (cm)	TABLE ANGLE (Degree)	REMARK
5725	45.84	36.68	75.48	-29.64	34.62	8.65	34.11	100	298	Average
5725	57.67	48.51	82.96	-25.29	34.62	8.65	34.11	100	298	Peak
5785	95.48	86.25			34.68	8.68	34.13	100	298	Average
5785	102.96	93.73			34.68	8.68	34.13	100	298	Peak
5850	46.95	37.65	75.48	-28.53	34.74	8.7	34.14	100	298	Average
5850	58.94	49.64	82.96	-24.02	34.74	8.7	34.14	100	298	Peak

ANTENNA POLARITY & TEST DISTANCE: VERTICAL AT 3 M										
FREQ. (MHz)	EMISSION LEVEL (dBuV/m)	READ LEVEL (dBuV)	LIMIT (dBuV/m)	MARGIN (dB)	ANTENNA FACTOR (dB/m)	CABLE LOSS (dB)	PREAMP FACTOR (dB)	ANTENNA HEIGHT (cm)	TABLE ANGLE (Degree)	REMARK
5725	45.84	36.68	77.34	-31.5	34.62	8.65	34.11	109	308	Average
5725	58.64	49.48	85.4	-26.76	34.62	8.65	34.11	109	308	Peak
5785	97.34	88.11			34.68	8.68	34.13	109	308	Average
5785	105.4	96.17			34.68	8.68	34.13	109	308	Peak
5850	45.97	36.67	77.34	-31.37	34.74	8.7	34.14	109	308	Average
5850	58.26	48.96	85.4	-27.14	34.74	8.7	34.14	109	308	Peak

REMARKS:

- Emission Level = Read Level + Antenna Factor + Cable Loss - Preamp Factor
Margin value = Emission level – Limit value
- 5785MHz: Fundamental frequency.
- 5725MHz & 5850MHz: Out of restricted band



A D T

EUT TEST CONDITION		MEASUREMENT DETAIL	
CHANNEL	Channel 165	FREQUENCY RANGE	1GHz ~ 40GHz
INPUT POWER	120Vac, 60 Hz	DETECTOR FUNCTION	Peak (PK) Average (AV)
ENVIRONMENTAL CONDITIONS	25deg. C, 65%RH	TESTED BY	Harry Hsueh

ANTENNA POLARITY & TEST DISTANCE: HORIZONTAL AT 3 M

FREQ. (MHz)	EMISSION LEVEL (dBuV/m)	READ LEVEL (dBuV)	LIMIT (dBuV/m)	MARGIN (dB)	ANTENNA FACTOR (dB/m)	CABLE LOSS (dB)	PREAMP FACTOR (dB)	ANTENNA HEIGHT (cm)	TABLE ANGLE (Degree)	REMARK
5725	46.8	37.64	74.02	-27.22	34.62	8.65	34.11	100	316	Average
5725	58.95	49.79	82	-23.05	34.62	8.65	34.11	100	316	Peak
5825	94.02	84.73			34.73	8.69	34.13	100	316	Average
5825	102	92.71			34.73	8.69	34.13	100	316	Peak
5850	46.02	36.72	74.02	-28	34.74	8.7	34.14	100	316	Average
5850	58.07	48.77	82	-23.93	34.74	8.7	34.14	100	316	Peak

ANTENNA POLARITY & TEST DISTANCE: VERTICAL AT 3 M

FREQ. (MHz)	EMISSION LEVEL (dBuV/m)	READ LEVEL (dBuV)	LIMIT (dBuV/m)	MARGIN (dB)	ANTENNA FACTOR (dB/m)	CABLE LOSS (dB)	PREAMP FACTOR (dB)	ANTENNA HEIGHT (cm)	TABLE ANGLE (Degree)	REMARK
5725	46.79	37.63	77.31	-30.52	34.62	8.65	34.11	101	316	Average
5725	57.38	48.22	84.77	-27.39	34.62	8.65	34.11	101	316	Peak
5825	97.31	88.02			34.73	8.69	34.13	101	316	Average
5825	104.77	95.48			34.73	8.69	34.13	101	316	Peak
5850	46.8	37.5	77.31	-30.51	34.74	8.7	34.14	101	316	Average
5850	58.37	49.07	84.77	-26.4	34.74	8.7	34.14	101	316	Peak

REMARKS:

- Emission Level = Read Level + Antenna Factor + Cable Loss - Preamp Factor
Margin value = Emission level – Limit value
- 5825MHz: Fundamental frequency.
- 5725MHz & 5850MHz: Out of restricted band



A D T

802.11n (20MHz)

EUT TEST CONDITION		MEASUREMENT DETAIL	
CHANNEL	Channel 149	FREQUENCY RANGE	1GHz ~ 40GHz
INPUT POWER	120Vac, 60 Hz	DETECTOR FUNCTION	Peak (PK) Average (AV)
ENVIRONMENTAL CONDITIONS	25deg. C, 65%RH	TESTED BY	Harry Hsueh

ANTENNA POLARITY & TEST DISTANCE: HORIZONTAL AT 3 M										
FREQ. (MHz)	EMISSION LEVEL (dBuV/m)	READ LEVEL (dBuV)	LIMIT (dBuV/m)	MARGIN (dB)	ANTENNA FACTOR (dB/m)	CABLE LOSS (dB)	PREAMP FACTOR (dB)	ANTENNA HEIGHT (cm)	TABLE ANGLE (Degree)	REMARK
5725	49.8	40.64	75.27	-25.47	34.62	8.65	34.11	101	296	Average
5725	61.27	52.11	83.03	-21.76	34.62	8.65	34.11	101	296	Peak
5745	95.27	86.08			34.64	8.66	34.11	101	296	Average
5745	103.03	93.84			34.64	8.66	34.11	101	296	Peak
5850	45.96	36.66	75.27	-29.31	34.74	8.7	34.14	101	296	Average
5850	58.34	49.04	83.03	-24.69	34.74	8.7	34.14	101	296	Peak
ANTENNA POLARITY & TEST DISTANCE: VERTICAL AT 3 M										
FREQ. (MHz)	EMISSION LEVEL (dBuV/m)	READ LEVEL (dBuV)	LIMIT (dBuV/m)	MARGIN (dB)	ANTENNA FACTOR (dB/m)	CABLE LOSS (dB)	PREAMP FACTOR (dB)	ANTENNA HEIGHT (cm)	TABLE ANGLE (Degree)	REMARK
5725	50.43	41.27	77.16	-26.73	34.62	8.65	34.11	100	308	Average
5725	63.75	54.59	84.09	-20.34	34.62	8.65	34.11	100	308	Peak
5745	97.16	87.97			34.64	8.66	34.11	100	308	Average
5745	104.09	94.9			34.64	8.66	34.11	100	308	Peak
5850	46.66	37.36	77.16	-30.5	34.74	8.7	34.14	100	308	Average
5850	59.43	50.13	84.09	-24.66	34.74	8.7	34.14	100	308	Peak

REMARKS:

1. Emission Level = Read Level + Antenna Factor + Cable Loss - Preamp Factor
Margin value = Emission level – Limit value
2. 5745MHz: Fundamental frequency.
3. 5725MHz & 5850MHz: Out of restricted band



A D T

EUT TEST CONDITION		MEASUREMENT DETAIL	
CHANNEL	Channel 157	FREQUENCY RANGE	1GHz ~ 40GHz
INPUT POWER	120Vac, 60 Hz	DETECTOR FUNCTION	Peak (PK) Average (AV)
ENVIRONMENTAL CONDITIONS	25deg. C, 65%RH	TESTED BY	Harry Hsueh

ANTENNA POLARITY & TEST DISTANCE: HORIZONTAL AT 3 M

FREQ. (MHz)	EMISSION LEVEL (dBuV/m)	READ LEVEL (dBuV)	LIMIT (dBuV/m)	MARGIN (dB)	ANTENNA FACTOR (dB/m)	CABLE LOSS (dB)	PREAMP FACTOR (dB)	ANTENNA HEIGHT (cm)	TABLE ANGLE (Degree)	REMARK
5725	45.79	36.63	75.99	-30.2	34.62	8.65	34.11	102	297	Average
5725	58.47	49.31	83.18	-24.71	34.62	8.65	34.11	102	297	Peak
5785	95.99	86.76			34.68	8.68	34.13	102	297	Average
5785	103.18	93.95			34.68	8.68	34.13	102	297	Peak
5850	46.18	36.88	75.99	-29.81	34.74	8.7	34.14	102	297	Average
5850	58.32	49.02	83.18	-24.86	34.74	8.7	34.14	102	297	Peak

ANTENNA POLARITY & TEST DISTANCE: VERTICAL AT 3 M

FREQ. (MHz)	EMISSION LEVEL (dBuV/m)	READ LEVEL (dBuV)	LIMIT (dBuV/m)	MARGIN (dB)	ANTENNA FACTOR (dB/m)	CABLE LOSS (dB)	PREAMP FACTOR (dB)	ANTENNA HEIGHT (cm)	TABLE ANGLE (Degree)	REMARK
5725	45.8	36.64	78.91	-33.11	34.62	8.65	34.11	100	308	Average
5725	57.59	48.43	85.05	-27.46	34.62	8.65	34.11	100	308	Peak
5785	98.91	89.68			34.68	8.68	34.13	100	308	Average
5785	105.05	95.82			34.68	8.68	34.13	100	308	Peak
5850	45.96	36.66	78.91	-32.95	34.74	8.7	34.14	100	308	Average
5850	58.24	48.94	85.05	-26.81	34.74	8.7	34.14	100	308	Peak

REMARKS:

- Emission Level = Read Level + Antenna Factor + Cable Loss - Preamp Factor
Margin value = Emission level – Limit value
- 5785MHz: Fundamental frequency.
- 5725MHz & 5850MHz: Out of restricted band



A D T

EUT TEST CONDITION		MEASUREMENT DETAIL	
CHANNEL	Channel 165	FREQUENCY RANGE	1GHz ~ 40GHz
INPUT POWER	120Vac, 60 Hz	DETECTOR FUNCTION	Peak (PK) Average (AV)
ENVIRONMENTAL CONDITIONS	25deg. C, 65%RH	TESTED BY	Harry Hsueh

ANTENNA POLARITY & TEST DISTANCE: HORIZONTAL AT 3 M

FREQ. (MHz)	EMISSION LEVEL (dBuV/m)	READ LEVEL (dBuV)	LIMIT (dBuV/m)	MARGIN (dB)	ANTENNA FACTOR (dB/m)	CABLE LOSS (dB)	PREAMP FACTOR (dB)	ANTENNA HEIGHT (cm)	TABLE ANGLE (Degree)	REMARK
5725	45.83	36.67	75.1	-29.27	34.62	8.65	34.11	102	316	Average
5725	59	49.84	82.28	-23.28	34.62	8.65	34.11	102	316	Peak
5825	95.1	85.81			34.73	8.69	34.13	102	316	Average
5825	102.28	92.99			34.73	8.69	34.13	102	316	Peak
5850	45.96	36.66	75.1	-29.14	34.74	8.7	34.14	102	316	Average
5850	58.32	49.02	82.28	-23.96	34.74	8.7	34.14	102	316	Peak

ANTENNA POLARITY & TEST DISTANCE: VERTICAL AT 3 M

FREQ. (MHz)	EMISSION LEVEL (dBuV/m)	READ LEVEL (dBuV)	LIMIT (dBuV/m)	MARGIN (dB)	ANTENNA FACTOR (dB/m)	CABLE LOSS (dB)	PREAMP FACTOR (dB)	ANTENNA HEIGHT (cm)	TABLE ANGLE (Degree)	REMARK
5725	45.8	36.64	77.4	-31.6	34.62	8.65	34.11	100	270	Average
5725	58.56	49.4	85.32	-26.76	34.62	8.65	34.11	100	270	Peak
5825	97.4	88.11			34.73	8.69	34.13	100	270	Average
5825	105.32	96.03			34.73	8.69	34.13	100	270	Peak
5850	47.01	37.71	77.4	-30.39	34.74	8.7	34.14	100	270	Average
5850	58.92	49.62	85.32	-26.4	34.74	8.7	34.14	100	270	Peak

REMARKS:

- Emission Level = Read Level + Antenna Factor + Cable Loss - Preamp Factor
Margin value = Emission level – Limit value
- 5825MHz: Fundamental frequency.
- 5725MHz & 5850MHz: Out of restricted band



A D T

802.11n (40MHz)

EUT TEST CONDITION		MEASUREMENT DETAIL	
CHANNEL	Channel 151	FREQUENCY RANGE	1GHz ~ 40GHz
INPUT POWER	120Vac, 60 Hz	DETECTOR FUNCTION	Peak (PK) Average (AV)
ENVIRONMENTAL CONDITIONS	25deg. C, 65%RH	TESTED BY	Harry Hsueh

ANTENNA POLARITY & TEST DISTANCE: HORIZONTAL AT 3 M

FREQ. (MHz)	EMISSION LEVEL (dBuV/m)	READ LEVEL (dBuV)	LIMIT (dBuV/m)	MARGIN (dB)	ANTENNA FACTOR (dB/m)	CABLE LOSS (dB)	PREAMP FACTOR (dB)	ANTENNA HEIGHT (cm)	TABLE ANGLE (Degree)	REMARK
5725	51.13	41.97	73.18	-22.05	34.62	8.65	34.11	101	296	Average
5725	65.58	56.42	80.93	-15.35	34.62	8.65	34.11	101	296	Peak
5755	93.18	83.97			34.66	8.66	34.11	101	296	Average
5755	100.93	91.72			34.66	8.66	34.11	101	296	Peak
5850	45.97	36.67	73.18	-27.21	34.74	8.7	34.14	101	296	Average
5850	58.16	48.86	80.93	-22.77	34.74	8.7	34.14	101	296	Peak

ANTENNA POLARITY & TEST DISTANCE: VERTICAL AT 3 M

FREQ. (MHz)	EMISSION LEVEL (dBuV/m)	READ LEVEL (dBuV)	LIMIT (dBuV/m)	MARGIN (dB)	ANTENNA FACTOR (dB/m)	CABLE LOSS (dB)	PREAMP FACTOR (dB)	ANTENNA HEIGHT (cm)	TABLE ANGLE (Degree)	REMARK
5725	51.84	42.68	75.84	-24	34.62	8.65	34.11	100	308	Average
5725	64.1	54.94	82.74	-18.64	34.62	8.65	34.11	100	308	Peak
5755	95.84	86.63			34.66	8.66	34.11	100	308	Average
5755	102.74	93.53			34.66	8.66	34.11	100	308	Peak
5850	45.96	36.66	75.84	-29.88	34.74	8.7	34.14	100	308	Average
5850	58.56	49.26	82.74	-24.18	34.74	8.7	34.14	100	308	Peak

REMARKS:

- Emission Level = Read Level + Antenna Factor + Cable Loss - Preamp Factor
Margin value = Emission level – Limit value
- 5755MHz: Fundamental frequency.
- 5725MHz & 5850MHz: Out of restricted band



A D T

EUT TEST CONDITION		MEASUREMENT DETAIL	
CHANNEL	Channel 159	FREQUENCY RANGE	1GHz ~ 40GHz
INPUT POWER	120Vac, 60 Hz	DETECTOR FUNCTION	Peak (PK) Average (AV)
ENVIRONMENTAL CONDITIONS	25deg. C, 65%RH	TESTED BY	Harry Hsueh

ANTENNA POLARITY & TEST DISTANCE: HORIZONTAL AT 3 M

FREQ. (MHz)	EMISSION LEVEL (dBuV/m)	READ LEVEL (dBuV)	LIMIT (dBuV/m)	MARGIN (dB)	ANTENNA FACTOR (dB/m)	CABLE LOSS (dB)	PREAMP FACTOR (dB)	ANTENNA HEIGHT (cm)	TABLE ANGLE (Degree)	REMARK
5725	45.79	36.63	72.5	-26.71	34.62	8.65	34.11	110	297	Average
5725	60.16	51	80.09	-19.93	34.62	8.65	34.11	110	297	Peak
5795	92.5	83.26			34.69	8.68	34.13	110	297	Average
5795	100.09	90.85			34.69	8.68	34.13	110	297	Peak
5850	44.97	35.67	72.5	-27.53	34.74	8.7	34.14	110	297	Average
5850	58.83	49.53	80.09	-21.26	34.74	8.7	34.14	110	297	Peak

ANTENNA POLARITY & TEST DISTANCE: VERTICAL AT 3 M

FREQ. (MHz)	EMISSION LEVEL (dBuV/m)	READ LEVEL (dBuV)	LIMIT (dBuV/m)	MARGIN (dB)	ANTENNA FACTOR (dB/m)	CABLE LOSS (dB)	PREAMP FACTOR (dB)	ANTENNA HEIGHT (cm)	TABLE ANGLE (Degree)	REMARK
5725	47.48	38.32	75.43	-27.95	34.62	8.65	34.11	100	311	Average
5725	60.77	51.61	82.38	-21.61	34.62	8.65	34.11	100	311	Peak
5795	95.43	86.19			34.69	8.68	34.13	100	311	Average
5795	102.38	93.14			34.69	8.68	34.13	100	311	Peak
5850	45.99	36.69	75.43	-29.44	34.74	8.7	34.14	100	311	Average
5850	62.32	53.02	82.38	-20.06	34.74	8.7	34.14	100	311	Peak

REMARKS:

- Emission Level = Read Level + Antenna Factor + Cable Loss - Preamp Factor
Margin value = Emission level – Limit value
- 5795MHz: Fundamental frequency.
- 5725MHz & 5850MHz: Out of restricted band



A D T

802.11ac (80MHz)

EUT TEST CONDITION		MEASUREMENT DETAIL	
CHANNEL	Channel 155	FREQUENCY RANGE	1GHz ~ 40GHz
INPUT POWER	120Vac, 60 Hz	DETECTOR FUNCTION	Peak (PK) Average (AV)
ENVIRONMENTAL CONDITIONS	25deg. C, 65%RH	TESTED BY	Harry Hsueh

ANTENNA POLARITY & TEST DISTANCE: HORIZONTAL AT 3 M

FREQ. (MHz)	EMISSION LEVEL (dBuV/m)	READ LEVEL (dBuV)	LIMIT (dBuV/m)	MARGIN (dB)	ANTENNA FACTOR (dB/m)	CABLE LOSS (dB)	PREAMP FACTOR (dB)	ANTENNA HEIGHT (cm)	TABLE ANGLE (Degree)	REMARK
5725	49.8	40.64	70.2	-20.4	34.62	8.65	34.11	100	296	Average
5725	63.86	54.7	77.46	-13.6	34.62	8.65	34.11	100	296	Peak
5775	90.2	80.97			34.68	8.67	34.12	100	296	Average
5775	97.46	88.23			34.68	8.67	34.12	100	296	Peak
5850	46.97	37.67	70.2	-23.23	34.74	8.7	34.14	100	296	Average
5850	57.63	48.33	77.46	-19.83	34.74	8.7	34.14	100	296	Peak

ANTENNA POLARITY & TEST DISTANCE: VERTICAL AT 3 M

FREQ. (MHz)	EMISSION LEVEL (dBuV/m)	READ LEVEL (dBuV)	LIMIT (dBuV/m)	MARGIN (dB)	ANTENNA FACTOR (dB/m)	CABLE LOSS (dB)	PREAMP FACTOR (dB)	ANTENNA HEIGHT (cm)	TABLE ANGLE (Degree)	REMARK
5725	51.84	42.68	72.24	-20.4	34.62	8.65	34.11	100	304	Average
5725	68.36	59.2	79.36	-11	34.62	8.65	34.11	100	304	Peak
5775	92.24	83.01			34.68	8.67	34.12	100	304	Average
5775	99.36	90.13			34.68	8.67	34.12	100	304	Peak
5850	45.96	36.66	72.24	-26.28	34.74	8.7	34.14	100	304	Average
5850	59.14	49.84	79.36	-20.22	34.74	8.7	34.14	100	304	Peak

REMARKS:

- Emission Level = Read Level + Antenna Factor + Cable Loss - Preamp Factor
Margin value = Emission level – Limit value
- 5775MHz: Fundamental frequency.
- 5725MHz & 5850MHz: Out of restricted band



A D T

BELOW 1GHz WORST-CASE DATA :

802.11ac (80MHz)

EUT TEST CONDITION		MEASUREMENT DETAIL	
CHANNEL	Channel 155	FREQUENCY RANGE	30MHz ~ 1GHz
INPUT POWER	120Vac, 60 Hz	DETECTOR FUNCTION	Peak (PK) Quasi-peak (QP)
ENVIRONMENTAL CONDITIONS	25deg. C, 65%RH	TESTED BY	Harry Hsueh

ANTENNA POLARITY & TEST DISTANCE: HORIZONTAL AT 3 M

FREQ. (MHz)	EMISSION LEVEL (dBuV/m)	READ LEVEL (dBuV)	LIMIT (dBuV/m)	MARGIN (dB)	ANTENNA FACTOR (dB/m)	CABLE LOSS (dB)	PREAMP FACTOR (dB)	ANTENNA HEIGHT (cm)	TABLE ANGLE (Degree)	REMARK
86.43	33.78	55.85	40	-6.22	8.73	1.11	31.91	165	124	Peak
143.67	31.76	53.04	43.5	-11.74	9.61	1.38	32.27	155	124	Peak
179.85	33.11	53.38	43.5	-10.39	10.36	1.61	32.24	185	125	Peak
367.9	31.07	44.61	46	-14.93	16.32	2.26	32.12	166	235	Peak
529.6	20.61	29.46	46	-25.39	20.61	2.7	32.16	165	210	Peak
673.1	24.88	30.55	46	-21.12	23.4	3.05	32.12	157	125	Peak

ANTENNA POLARITY & TEST DISTANCE: VERTICAL AT 3 M

FREQ. (MHz)	EMISSION LEVEL (dBuV/m)	READ LEVEL (dBuV)	LIMIT (dBuV/m)	MARGIN (dB)	ANTENNA FACTOR (dB/m)	CABLE LOSS (dB)	PREAMP FACTOR (dB)	ANTENNA HEIGHT (cm)	TABLE ANGLE (Degree)	REMARK
79.68	35.6	58.31	40	-4.4	8.39	1.11	32.21	166	210	Peak
143.67	26.89	48.17	43.5	-16.61	9.61	1.38	32.27	156	220	Peak
179.85	28.39	48.66	43.5	-15.11	10.36	1.61	32.24	168	168	Peak
380.5	26.07	39.22	46	-19.93	16.75	2.26	32.16	165	221	Peak
556.2	20.52	29.71	46	-25.48	20.25	2.76	32.2	152	102	Peak
641.6	22.71	29.78	46	-23.29	22.1	2.99	32.16	175	110	Peak

REMARKS: Emission Level = Read Level + Antenna Factor + Cable Loss - Preamp Factor

Margin value = Emission level – Limit value

5.2 CONDUCTED EMISSION MEASUREMENT

5.2.1 LIMITS OF CONDUCTED EMISSION MEASUREMENT

FREQUENCY OF EMISSION (MHz)	CONDUCTED LIMIT (dB μ V)	
	Quasi-peak	Average
0.15 ~ 0.5	66 to 56	56 to 46
0.5 ~ 5	56	46
5 ~ 30	60	50

- NOTE:**
1. The lower limit shall apply at the transition frequencies.
 2. The limit decreases in line with the logarithm of the frequency in the range of 0.15 to 0.50MHz.
 3. All emanations from a class A/B digital device or system, including any network of conductors and apparatus connected thereto, shall not exceed the level of field strengths specified above.

5.2.2 TEST INSTRUMENTS

Same as section 4.2.2.

5.2.3 TEST PROCEDURES

Same as section 4.2.3.

5.2.4 DEVIATION FROM TEST STANDARD

No deviation.

5.2.5 TEST SETUP

Same as section 4.2.5.

5.2.6 EUT OPERATING CONDITIONS

Same as section 4.1.6.

5.2.7 TEST RESULTS

CONDUCTED WORST-CASE DATA :

PHASE	Line 1	6dB BANDWIDTH	9kHz
-------	--------	---------------	------

No	Freq. [MHz]	Corr. Factor (dB)	Reading Value [dB (uV)]		Emission Level [dB (uV)]		Limit [dB (uV)]		Margin (dB)	
			Q.P.	AV.	Q.P.	AV.	Q.P.	AV.	Q.P.	AV.
			1	0.16562	0.27	50.85	34.55	51.12	34.82	65.18
2	0.38438	0.30	32.71	22.43	33.01	22.73	58.18	48.18	-25.18	-25.46
3	1.14453	0.34	34.89	24.42	35.23	24.76	56.00	46.00	-20.77	-21.24
4	2.15625	0.37	36.99	26.30	37.36	26.67	56.00	46.00	-18.64	-19.33
5	13.55859	0.52	52.12	48.20	52.64	48.72	60.00	50.00	-7.36	-1.28
6	22.39844	0.56	37.26	30.95	37.82	31.51	60.00	50.00	-22.18	-18.49

REMARKS:

1. Q.P. and AV. are abbreviations of quasi-peak and average individually.
2. The emission levels of other frequencies were very low against the limit.
3. Margin value = Emission level - Limit value
4. Correction factor = Insertion loss + Cable loss
5. Emission Level = Correction Factor + Reading Value

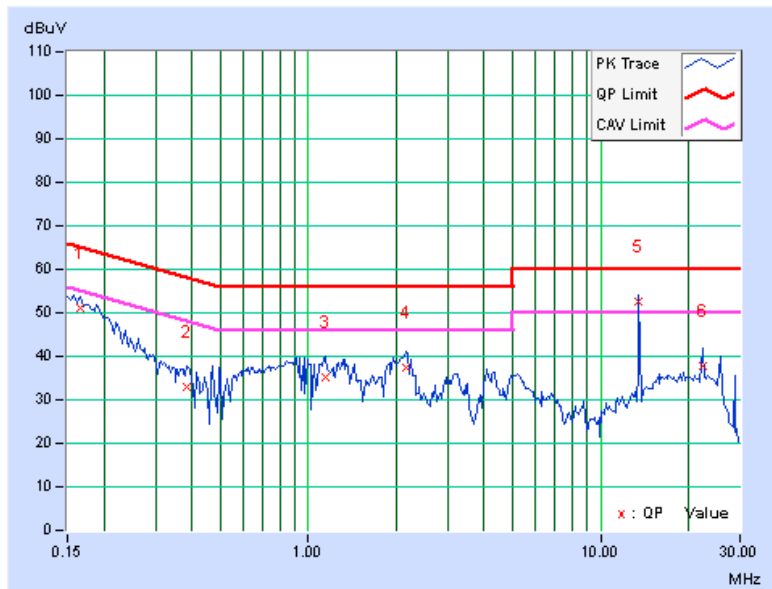

PHASE	Line 2	6dB BANDWIDTH	9kHz
-------	--------	---------------	------

No	Freq. [MHz]	Corr. Factor (dB)	Reading Value [dB (uV)]		Emission Level [dB (uV)]		Limit [dB (uV)]		Margin (dB)	
			Q.P.	AV.	Q.P.	AV.	Q.P.	AV.	Q.P.	AV.
			1	0.15781	0.27	49.40	33.53	49.67	33.80	65.58
2	0.47031	0.30	36.25	29.53	36.55	29.83	56.51	46.51	-19.95	-16.67
3	1.98438	0.37	29.95	19.31	30.32	19.68	56.00	46.00	-25.68	-26.32
4	4.16406	0.44	26.45	15.71	26.89	16.15	56.00	46.00	-29.11	-29.85
5	13.56250	0.55	46.84	41.86	47.39	42.41	60.00	50.00	-12.61	-7.59
6	22.40234	0.60	33.09	24.73	33.69	25.33	60.00	50.00	-26.31	-24.67

REMARKS:

1. Q.P. and AV. are abbreviations of quasi-peak and average individually.
2. The emission levels of other frequencies were very low against the limit.
3. Margin value = Emission level - Limit value
4. Correction factor = Insertion loss + Cable loss
5. Emission Level = Correction Factor + Reading Value

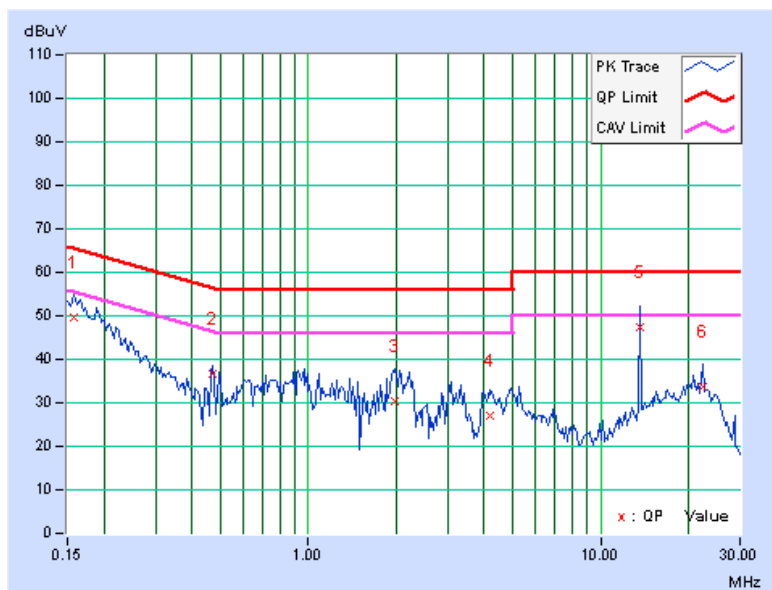



A D T

5.3 6dB BANDWIDTH MEASUREMENT

5.3.1 LIMITS OF 6dB BANDWIDTH MEASUREMENT

The minimum of 6dB Bandwidth Measurement is 0.5MHz.

5.3.2 TEST SETUP

Same as section 4.3.2.

5.3.3 TEST INSTRUMENTS

Refer to section 4.1.2 to get information of above instrument.

5.3.4 TEST PROCEDURE

Same as section 4.3.4.

5.3.5 DEVIATION FROM TEST STANDARD

No deviation.

5.3.6 EUT OPERATING CONDITIONS

Same as section 4.3.6.



5.3.7 TEST RESULTS

802.11a

CHANNEL	FREQUENCY (MHz)	6dB BANDWIDTH (MHz)	MINIMUM LIMIT (MHz)	PASS / FAIL
149	5745	16.44	0.5	PASS
157	5785	16.40	0.5	PASS
165	5825	16.40	0.5	PASS

802.11n (20MHz)

CHANNEL	FREQUENCY (MHz)	6dB BANDWIDTH (MHz)	MINIMUM LIMIT (MHz)	PASS / FAIL
149	5745	17.61	0.5	PASS
157	5785	17.63	0.5	PASS
165	5825	17.64	0.5	PASS

802.11n (40MHz)

CHANNEL	FREQUENCY (MHz)	6dB BANDWIDTH (MHz)	MINIMUM LIMIT (MHz)	PASS / FAIL
151	5755	35.53	0.5	PASS
159	5795	35.20	0.5	PASS

802.11ac (80MHz)

CHANNEL	FREQUENCY (MHz)	6dB BANDWIDTH (MHz)	MINIMUM LIMIT (MHz)	PASS / FAIL
155	5775	73.96	0.5	PASS



A D T

SPECTRUM PLOT OF WORST VALUE

802.11a

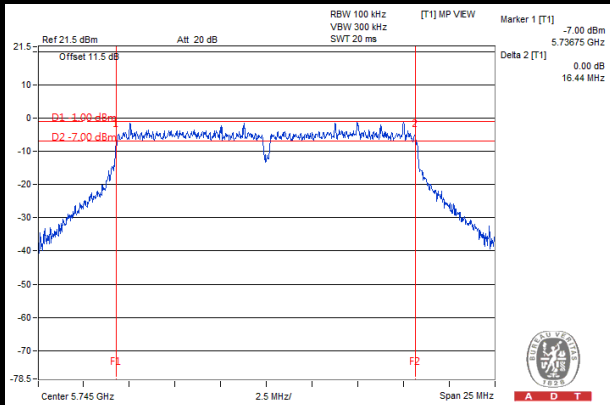

802.11n (20MHz)

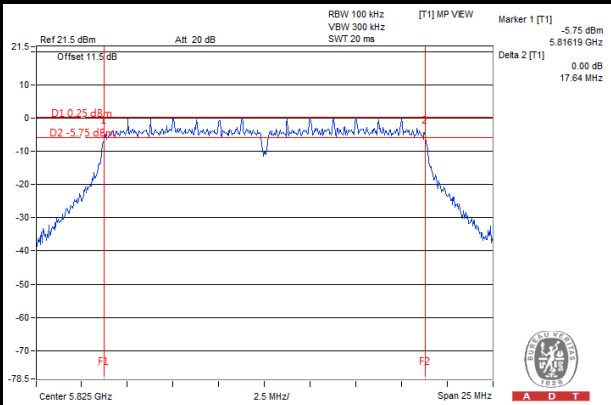

802.11n (40MHz)

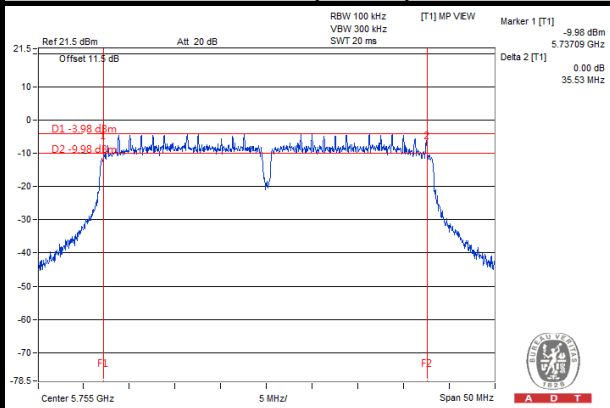

802.11ac (80MHz)

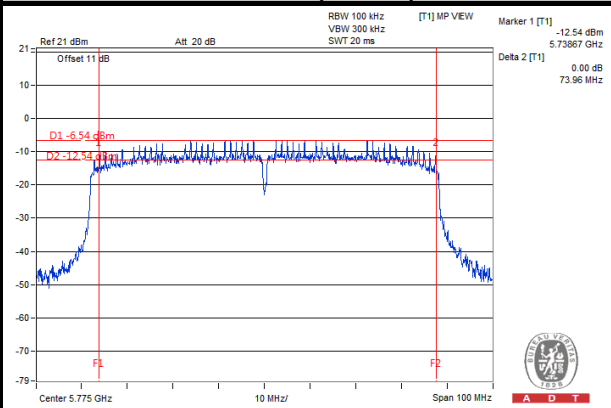

5.4 MAXIMUM OUTPUT POWER

5.4.1 LIMITS OF MAXIMUM OUTPUT POWER MEASUREMENT

For systems using digital modulation in the 5725–5850 MHz bands: 1 Watt (30dBm)

5.4.2 TEST SETUP

Same as section 4.4.2.

5.4.3 INSTRUMENTS

Refer to section 4.1.2 to get information of above instrument.

5.4.4 TEST PROCEDURES

Same as section 4.4.4.

5.4.5 DEVIATION FROM TEST STANDARD

No deviation.

5.4.6 EUT OPERATING CONDITIONS

Same as section 4.3.6.



A D T

5.4.7 TEST RESULTS

802.11a

CHANNEL	FREQUENCY (MHz)	PEAK POWER (mW)	PEAK POWER (dBm)	LIMIT (dBm)	PASS / FAIL
149	5745	161.065	22.07	30	PASS
157	5785	173.380	22.39	30	PASS
165	5825	168.267	22.26	30	PASS

802.11n (20MHz)

CHANNEL	FREQUENCY (MHz)	PEAK POWER (mW)	PEAK POWER (dBm)	LIMIT (dBm)	PASS / FAIL
149	5745	157.398	21.97	30	PASS
157	5785	178.649	22.52	30	PASS
165	5825	153.815	21.87	30	PASS

802.11n (40MHz)

CHANNEL	FREQUENCY (MHz)	PEAK POWER (mW)	PEAK POWER (dBm)	LIMIT (dBm)	PASS / FAIL
151	5755	140.605	21.48	30	PASS
159	5795	154.525	21.89	30	PASS

802.11ac (80MHz)

CHANNEL	FREQUENCY (MHz)	PEAK POWER (mW)	PEAK POWER (dBm)	LIMIT (dBm)	PASS / FAIL
155	5775	68.234	18.34	30	PASS



A D T

5.5 POWER SPECTRAL DENSITY MEASUREMENT

5.5.1 LIMITS OF POWER SPECTRAL DENSITY MEASUREMENT

The Maximum of Power Spectral Density Measurement is 8dBm.

5.5.2 TEST SETUP

Same as section 4.5.2.

5.5.3 TEST INSTRUMENTS

Refer to section 4.1.2 to get information of above instrument.

5.5.4 TEST PROCEDURE.

Same as section 4.5.4.

5.5.5 DEVIATION FROM TEST STANDARD

No deviation.

5.5.6 EUT OPERATING CONDITION

Same as section 4.3.6.



A D T

5.5.7 TEST RESULTS

802.11a

CHANNEL	FREQUENCY (MHz)	PSD (dBm/3kHz)	LIMIT (dBm/3kHz)	PASS / FAIL
149	5745	-14.92	8	PASS
157	5785	-13.52	8	PASS
165	5825	-14.76	8	PASS

802.11n (20MHz)

CHANNEL	FREQUENCY (MHz)	PSD (dBm/3kHz)	LIMIT (dBm/3kHz)	PASS / FAIL
149	5745	-15.20	8	PASS
157	5785	-13.69	8	PASS
165	5825	-13.96	8	PASS

802.11n (40MHz)

CHANNEL	FREQUENCY (MHz)	PSD (dBm/3kHz)	LIMIT (dBm/3kHz)	PASS / FAIL
151	5755	-17.42	8	PASS
159	5795	-18.01	8	PASS

802.11ac (80MHz)

CHANNEL	FREQUENCY (MHz)	PSD (dBm/3kHz)	LIMIT (dBm/3kHz)	PASS / FAIL
155	5775	-21.08	8	PASS



A D T

SPECTRUM PLOT OF WORST VALUE

802.11a

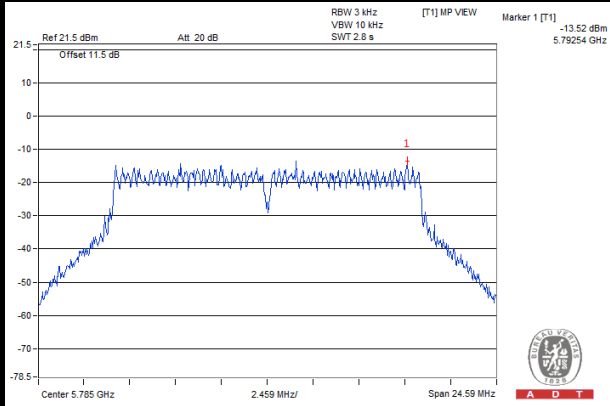

802.11n (20MHz)

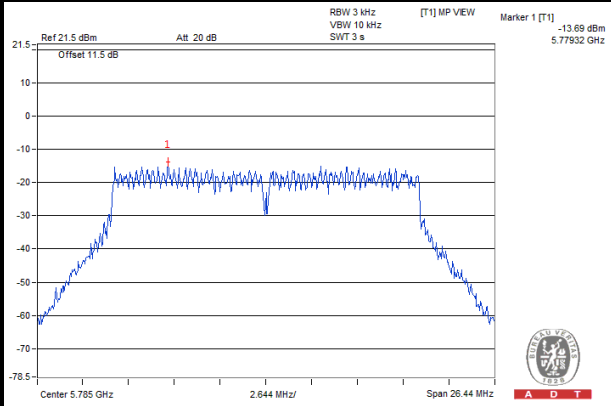

802.11n (40MHz)

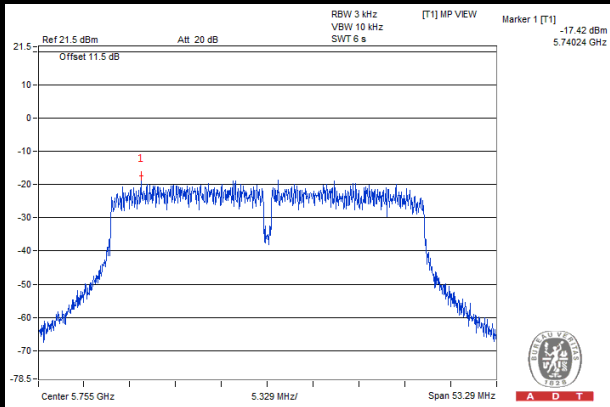

802.11ac (80MHz)

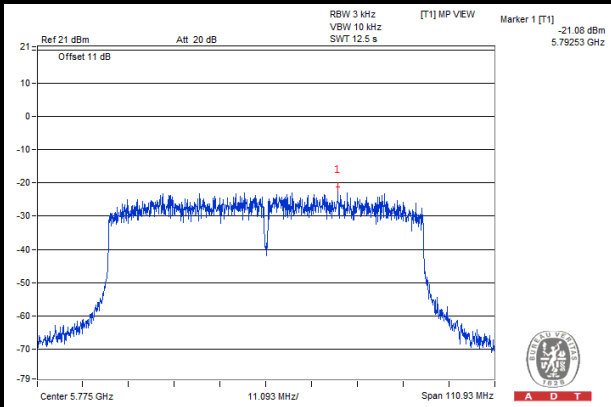

5.6 CONDUCTED OUT OF BAND EMISSION MEASUREMENT

5.6.1 LIMITS OF OUT OF BAND EMISSION MEASUREMENT

Below -20dB of the highest emission level of operating band (in 100kHz Resolution Bandwidth).

5.6.2 TEST SETUP

Same as section 4.6.2.

5.6.3 TEST INSTRUMENTS

Refer to section 4.1.2 to get information of above instrument.

5.6.4 TEST PROCEDURE

Same as section 4.6.4

5.6.5 DEVIATION FROM TEST STANDARD

No deviation.

5.6.6 EUT OPERATING CONDITION

Same as section 4.3.6

5.6.7 TEST RESULTS

The spectrum plots are attached on the following pages. D1 line indicates the highest level, and D2 line indicates the 20dB offset below D1. It shows compliance with the requirement.



A D T

802.11a

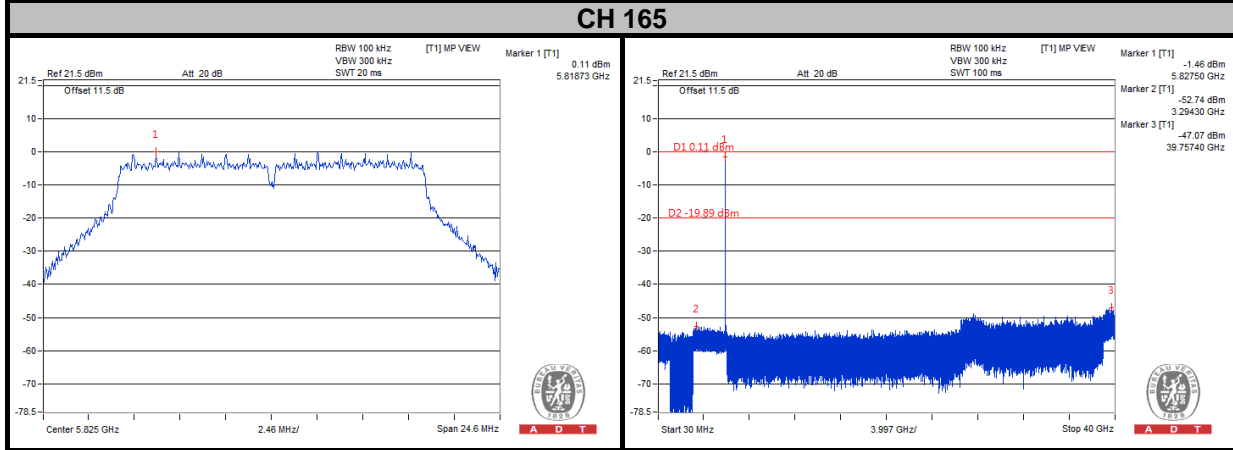
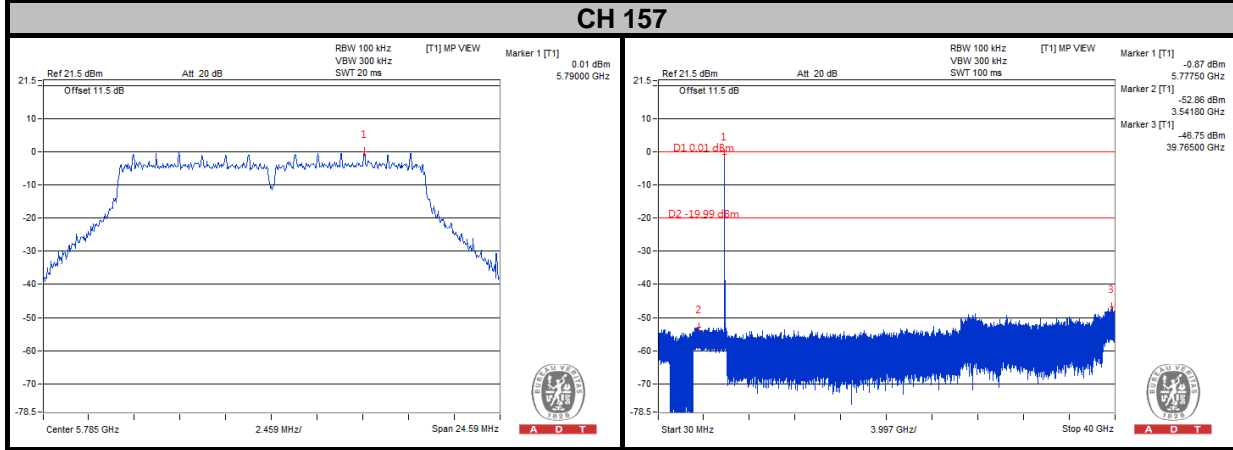
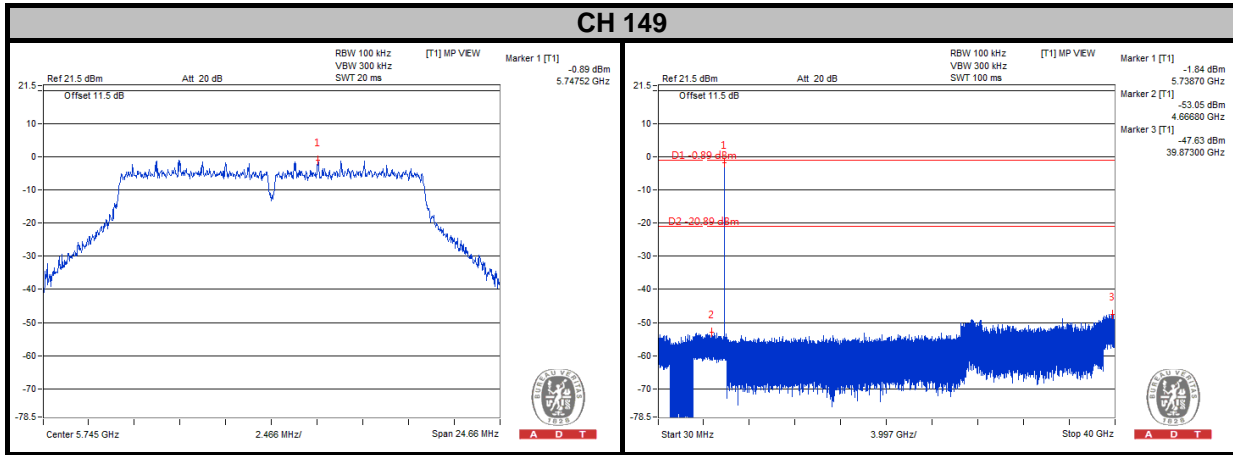



A D T

802.11n (20MHz)

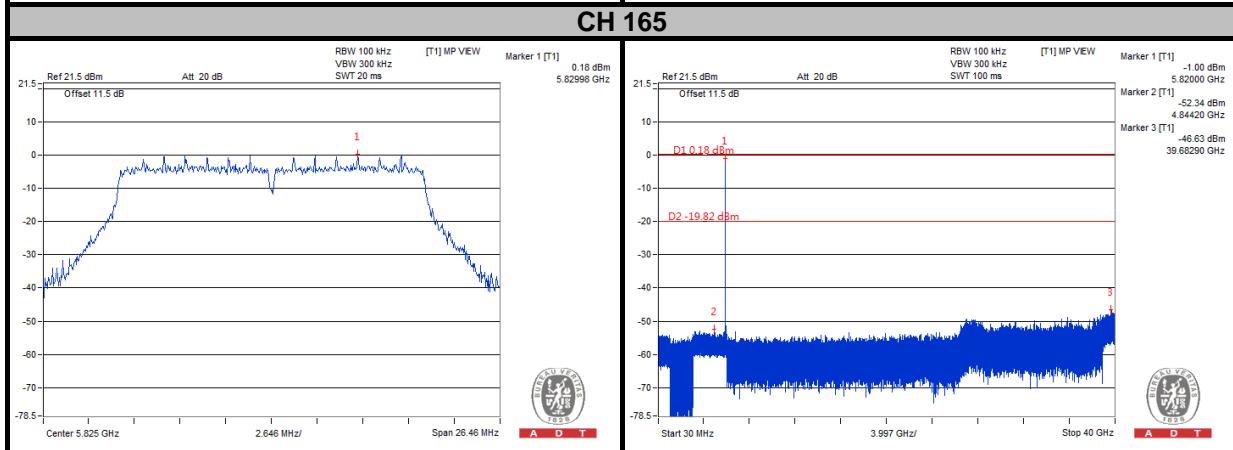
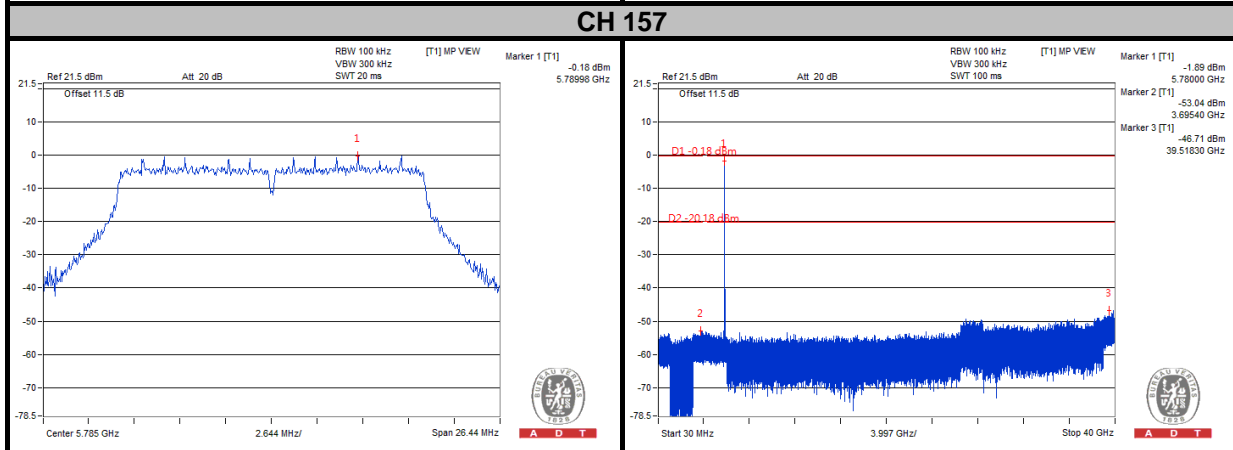
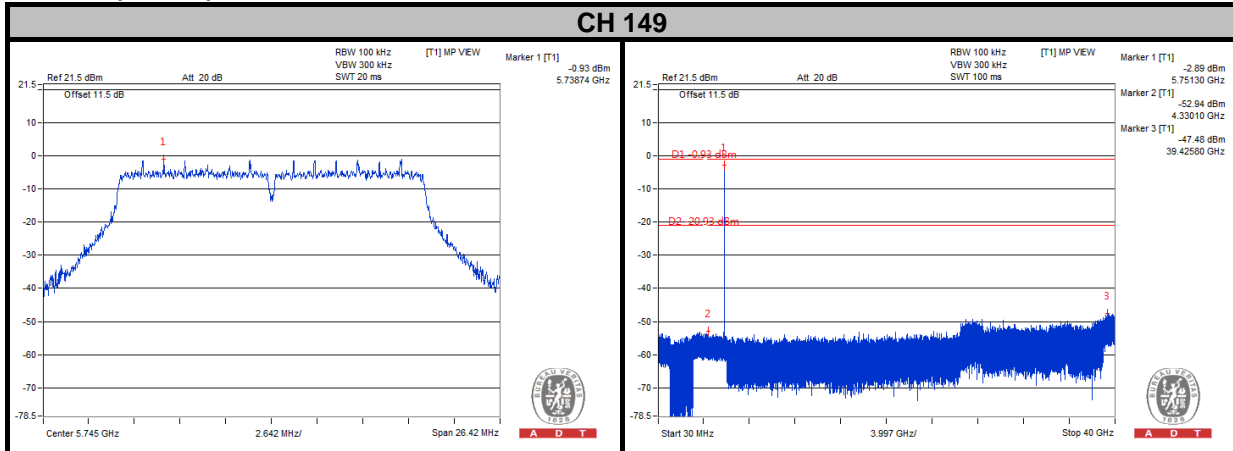



A D T

802.11n (40MHz)

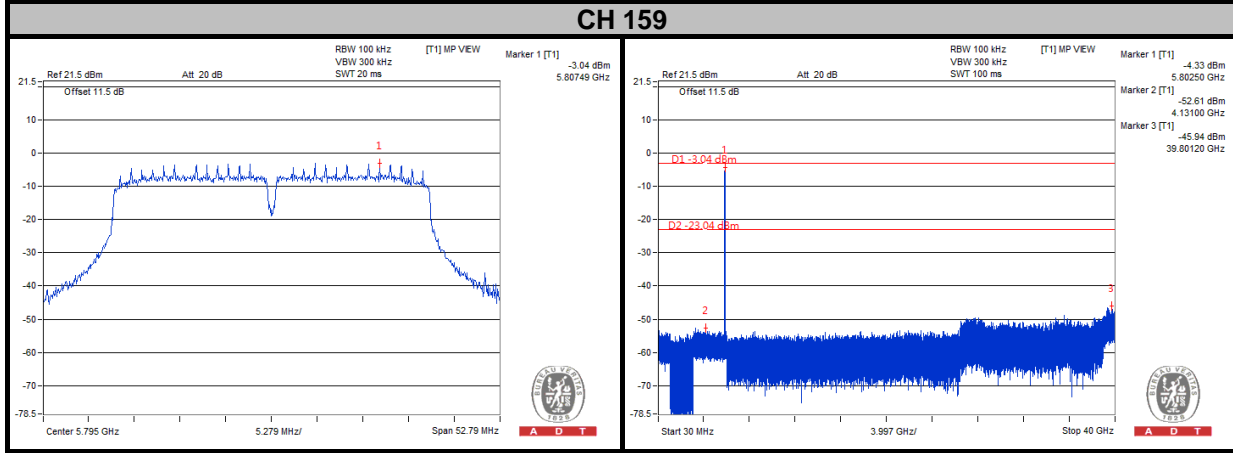
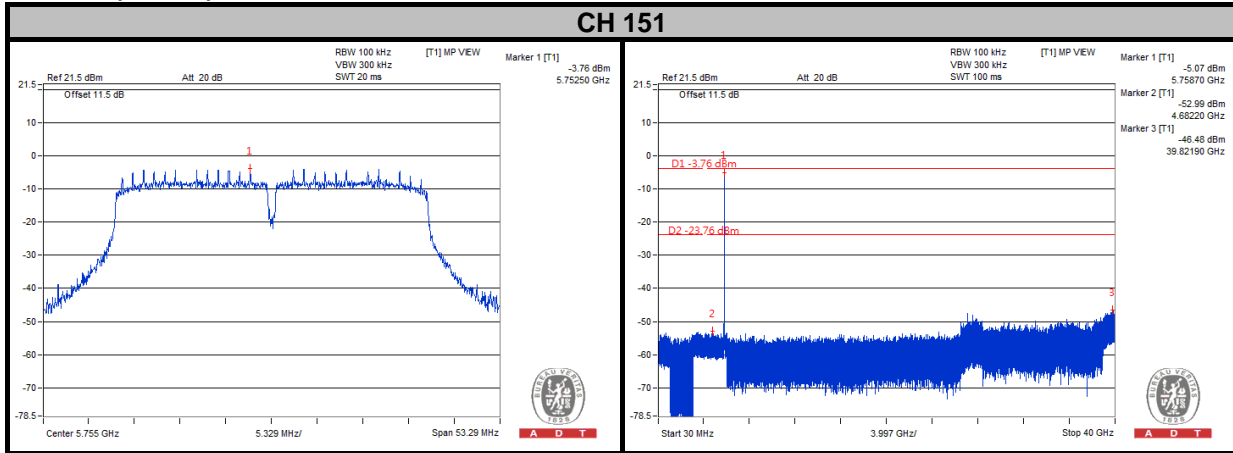

802.11ac (80MHz)

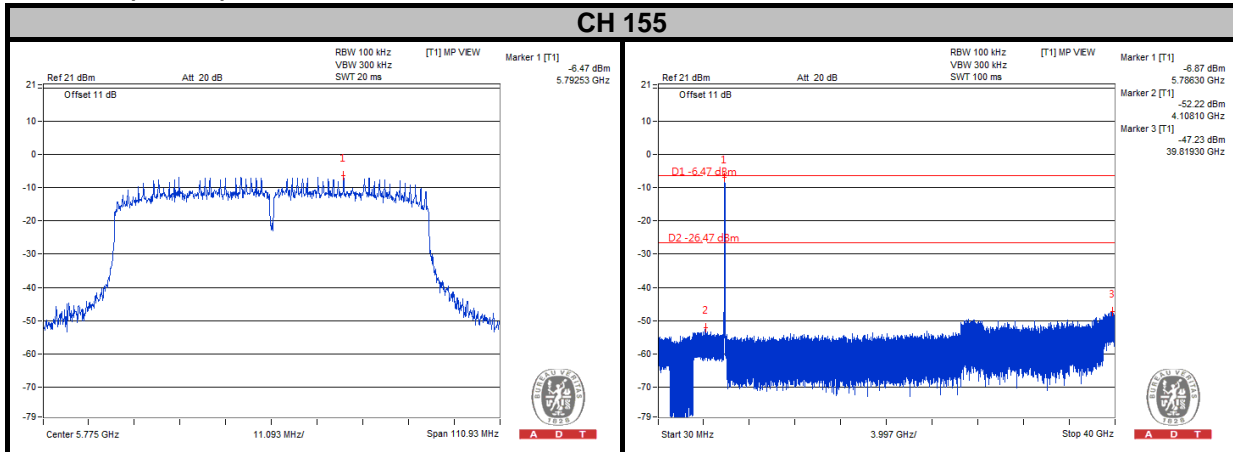



A D T

6. PHOTOGRAPHS OF THE TEST CONFIGURATION

Please refer to the attached file (Test Setup Photo).



7. INFORMATION ON THE TESTING LABORATORIES

We, Bureau Veritas Consumer Products Services (H.K.) Ltd., Taoyuan Branch, were founded in 1988 to provide our best service in EMC, Radio, Telecom and Safety consultation. Our laboratories are accredited and approved according to ISO/IEC 17025.

If you have any comments, please feel free to contact us at the following:

Linko EMC/RF Lab:

Tel: 886-2-26052180

Fax: 886-2-26051924

Hsin Chu EMC/RF Lab:

Tel: 886-3-5935343

Fax: 886-3-5935342

Hwa Ya EMC/RF/Safety Telecom Lab:

Tel: 886-3-3183232

Fax: 886-3-3270892

Email: service.adt@tw.bureauveritas.com

Web Site: www.bureauveritas-adt.com

The address and road map of all our labs can be found in our web site also.



A D T

8. APPENDIX A – MODIFICATIONS RECORDERS FOR ENGINEERING CHANGES TO THE EUT BY THE LAB

No any modifications are made to the EUT by the lab during the test.

---END---