

TEST REPORT

CERTIFICATE OF CONFORMITY

Standard: 47 CFR FCC Part 15, Subpart E (Section 15.407)

Report No.: RFBFJZ-WTW-P22040598-3

FCC ID: V65E4811

Model No.: E4811

Series Model: E4811NC (refer to item 3.1 for more details)

Received Date: 2022/4/22

Test Date: 2022/5/20 ~ 2022/10/6

Issued Date: 2022/10/7

Applicant: Kyocera Corporation % Kyocera International, Inc.

Address: 8611 Balboa Avenue, San Diego, CA 92123

Issued By: Bureau Veritas Consumer Products Services (H.K.) Ltd., Taoyuan Branch
Lin Kou Laboratories

Lab Address: No. 47-2, 14th Ling, Chia Pau Vil., Lin Kou Dist., New Taipei City, Taiwan

Test Location (1): No.19, Hwa Ya 2nd Rd., Wen Hwa Vil., Kwei Shan Dist., Taoyuan City 33383, Taiwan

Test Location (2): B2F., No.215, Sec. 3, Beixin Rd., Xindian Dist., New Taipei City 231, Taiwan

FCC Registration / 788550 / TW0003

Designation Number: 427177 / TW0011

Approved by: _____

Jeremy Lin

Date: _____

2022/10/7

Jeremy Lin / Project Engineer

This test report consists of 115 pages in total. It may be duplicated completely for legal use with the approval of the applicant. It should not be reproduced except in full, without the written approval of our laboratory. The test results in the report only apply to the tested sample. The test results in this report are traceable to the national or international standards.

Prepared by : Vera Huang / Specialist



This report is governed by, and incorporates by reference, the Conditions of Testing as posted at the date of issuance of this report at <http://www.bureauveritas.com/home/about-us/our-business/cps/about-us/terms-conditions/> and is intended for your exclusive use. Any copying or replication of this report to or for any other person or entity, or use of our name or trademark, is permitted only with our prior written permission. This report sets forth our findings solely with respect to the test samples identified herein. The results set forth in this report are not indicative or representative of the quality or characteristics of the lot from which a test sample was taken or any similar or identical product unless specifically and expressly noted. Our report includes all of the tests requested by you and the results thereof based upon the information that you provided to us. Measurement uncertainty is only provided upon request for accredited tests. Statements of conformity are based on simple acceptance criteria without taking measurement uncertainty into account, unless otherwise requested in writing. You have 60 days from date of issuance of this report to notify us of any material error or omission caused by our negligence or if you require measurement uncertainty; provided, however, that such notice shall be in writing and shall specifically address the issue you wish to raise. A failure to raise such issue within the prescribed time shall constitute your unqualified acceptance of the completeness of this report, the tests conducted and the correctness of the report contents.

Table of Contents

Release Control Record	4
1 Certificate	5
2 Summary of Test Results	6
2.1 Measurement Uncertainty	6
2.2 Supplementary Information	6
3 General Information	7
3.1 General Description of EUT	7
3.2 Antenna Description of EUT	8
3.3 Channel List	9
3.4 Test Mode Applicability and Tested Channel Detail	11
3.5 Duty Cycle of Test Signal	13
3.6 Description of Support Units	14
3.6.1 Configuration of System under Test	14
4 Test Instruments	15
4.1 26 dB Bandwidth	15
4.2 RF Output Power	15
4.3 Power Spectral Density	15
4.4 6 dB Bandwidth	15
4.5 Occupied Bandwidth	15
4.6 Frequency Stability	16
4.7 AC Power Conducted Emissions	16
4.8 Unwanted Emissions below 1 GHz	17
4.9 Unwanted Emissions above 1 GHz	18
5 Limits of Test Items	19
5.1 26 dB Bandwidth	19
5.2 RF Output Power	19
5.3 Power Spectral Density	19
5.4 6 dB Bandwidth	19
5.5 Occupied Bandwidth	19
5.6 Frequency Stability	19
5.7 AC Power Conducted Emissions	20
5.8 Unwanted Emissions below 1 GHz	20
5.9 Unwanted Emissions above 1 GHz	21
6 Test Arrangements	22
6.1 26 dB Bandwidth	22
6.1.1 Test Setup	22
6.1.2 Test Procedure	22
6.2 RF Output Power	23
6.2.1 Test Setup	23
6.2.2 Test Procedure	23
6.3 Power Spectral Density	24
6.3.1 Test Setup	24
6.3.2 Test Procedure	24
6.4 6 dB Bandwidth	24
6.4.1 Test Setup	24
6.4.2 Test Procedure	24
6.5 Occupied Bandwidth	25
6.5.1 Test Setup	25
6.5.2 Test Procedure	25
6.6 Frequency Stability	25
6.6.1 Test Setup	25
6.6.2 Test Procedure	25
6.7 AC Power Conducted Emissions	26
6.7.1 Test Setup	26



6.7.2	Test Procedure.....	26
6.8	Unwanted Emissions below 1 GHz.....	27
6.8.1	Test Setup.....	27
6.8.2	Test Procedure.....	28
6.9	Unwanted Emissions above 1 GHz.....	29
6.9.1	Test Setup.....	29
6.9.2	Test Procedure.....	29
7	Test Results of Test Item.....	30
7.1	26 dB Bandwidth.....	30
7.2	RF Output Power.....	34
7.3	Power Spectral Density.....	41
7.4	6 dB Bandwidth.....	46
7.5	Occupied Bandwidth.....	48
7.6	Frequency Stability.....	53
7.7	AC Power Conducted Emissions.....	54
7.8	Unwanted Emissions below 1 GHz.....	56
7.9	Unwanted Emissions above 1 GHz.....	58
7.10	Band Edge Measurement.....	100
7.11	Radiated Out of Band Emission (OOBE) Measurement (For U-NII-3 band).....	112
8	Pictures of Test Arrangements.....	115
9	Information of the Testing Laboratories.....	116



Release Control Record

Issue No.	Description	Date Issued
RFBJZ-WTW-P22040598-3	Original release.	2022/10/7

1 Certificate

Product: Feature Phone

Brand: Kyocera

Test Model: E4811

Series Model: E4811NC (refer to item 3.1 for more details)

Sample Status: Identical Prototype

Applicant: Kyocera Corporation % Kyocera International, Inc.

Test Date: 2022/5/20 ~ 2022/10/6

Standard: 47 CFR FCC Part 15, Subpart E (Section 15.407)

Measurement ANSI C63.10-2013

procedure: KDB 789033 D02 General UNII Test Procedure New Rules v02r01

The above equipment has been tested by **Bureau Veritas Consumer Products Services (H.K.) Ltd., Taoyuan Branch**, and found compliance with the requirement of the above standards. The test record, data evaluation & Equipment Under Test (EUT) configurations represented herein are true and accurate accounts of the measurements of the sample's RF characteristics under the conditions specified in this report.

2 Summary of Test Results

47 CFR FCC Part 15, Subpart E (Section 15.407)			
Clause	Test Item	Result	Remark
15.407(a)(2)	26 dB Bandwidth	Pass	For U-NII-2A U-NII-2C Band output power limitation is determined based on 26dBc bandwidth.
15.407(a)(1/2/3)	RF Output Power	Pass	Meet the requirement of limit.
15.407(a)(1/2/3)	Power Spectral Density	Pass	Meet the requirement of limit.
15.407(e)	6 dB Bandwidth	Pass	Meet the requirement of limit. (U-NII-3 Band only)
---	Occupied Bandwidth	Pass	Reference only.
15.407(g)	Frequency Stability	Pass	Meet the requirement of limit.
15.407(b)(9)	AC Power Conducted Emissions	Pass	Minimum passing margin is -5.87 dB at 0.34577 MHz
15.407(b)(9)	Unwanted Emissions below 1 GHz	Pass	Minimum passing margin is -4.82 dB at 55.04 MHz
15.407(b)(1/2/3/4(i)/10)	Unwanted Emissions above 1 GHz	Pass	Minimum passing margin is -2.78 dB at 5460.00 MHz
15.203	Antenna Requirement	Pass	No antenna connector is used.

Note: Determining compliance based on the results of the compliance measurement, not taking into account measurement instrumentation uncertainty.

2.1 Measurement Uncertainty

Where relevant, the following measurement uncertainty levels have been estimated for tests performed on the EUT as specified in CISPR 16-4-2:

Measurement	Specification	Expanded Uncertainty (k=2) (±)
AC Power Conducted Emissions	9 kHz ~ 30 MHz	2.79 dB
Unwanted Emissions below 1 GHz	9 kHz ~ 30 MHz	3.04 dB
	30 MHz ~ 1 GHz	2.02 dB
Unwanted Emissions above 1 GHz	1 GHz ~ 18 GHz	1.01 dB
	18 GHz ~ 40 GHz	1.15 dB

The other instruments specified are routine verified to remain within the calibrated levels, no measurement uncertainty is required to be calculated.

2.2 Supplementary Information

There is not any deviation from the test standards for the test method, and no modifications required for compliance.

3 General Information

3.1 General Description of EUT

Product	Feature Phone
Brand	Kyocera
Test Model	E4811
Series Model	E4811NC
Status of EUT	Identical Prototype
Power Supply Rating	5 Vdc (from adapter) 3.8 Vdc (from Li-ion battery)
Modulation Type	256QAM, 64QAM, 16QAM, QPSK, BPSK
Modulation Technology	OFDM
Transfer Rate	802.11a: 54.0/ 48.0/ 36.0/ 24.0/ 18.0/ 12.0/ 9.0/ 6.0 Mbps 802.11n: up to 200 Mbps 802.11ac: up to 433.3 Mbps
Operating Frequency	5180 ~ 5240 MHz 5260 ~ 5320 MHz 5500 ~ 5720 MHz 5745 ~ 5825 MHz
Number of Channel	802.11a, 802.11n (HT20), 802.11ac (VHT20): 25 802.11n (HT40), 802.11ac (VHT40): 12 802.11ac (VHT80): 6
Output Power	5180 ~ 5240 MHz : 36.141 mW (15.58 dBm) 5260 ~ 5320 MHz : 34.995 mW (15.44 dBm) 5500 ~ 5720 MHz : 36.475 mW (15.62 dBm) 5745 ~ 5825 MHz : 35.481 mW (15.50 dBm)
EUT Category	Client device

Note:

1. All models are listed as below. The model of E4811 was chosen for final test.

Brand	Model	Difference
Kyocera	E4811	with Camera function
	E4811NC	without Camera function

2. The EUT contains following accessory devices.

Product	Brand	Model	Description
Adapter	Kyocera	SCP-47ADT	I/P: 100-240 Vac, 50/60 Hz, 200 mA O/P: 5 Vdc, 1000 mA
Battery	Kyocera	SCP-73LBPS	3.8 Vdc, 1770 mAh, 6.8Wh
USB Cable	Kyocera	SCP-24SDC	1 m shielded Type A to Type C USB cable w/o core

3. The above EUT information is declared by manufacturer and for more detailed features description, please refers to the manufacturer's specifications or User's Manual.

3.2 Antenna Description of EUT

1. The antenna information is listed as below.

Gain (dBi)	Antenna Type	Connector Type
3.79	Internal fixed monopole	N/A

* Detail antenna specification please refer to antenna datasheet and/or antenna measurement report.

2. The EUT provides 1 completed transmitter and 1 receiver.

5 GHz Band		
Modulation Mode	TX & RX Configuration	
802.11a	1TX	1RX
802.11n (HT20)	1TX	1RX
802.11n (HT40)	1TX	1RX
802.11ac (VHT20)	1TX	1RX
802.11ac (VHT40)	1TX	1RX
802.11ac (VHT80)	1TX	1RX

3.3 Channel List

FOR 5180 ~ 5320 MHz

8 channels are provided for 802.11a, 802.11n (HT20), 802.11ac (VHT20):

Channel	Frequency	Channel	Frequency
36	5180 MHz	52	5260 MHz
40	5200 MHz	56	5280 MHz
44	5220 MHz	60	5300 MHz
48	5240 MHz	64	5320 MHz

4 channels are provided for 802.11n (HT40), 802.11ac (VHT40):

Channel	Frequency	Channel	Frequency
38	5190 MHz	54	5270 MHz
46	5230 MHz	62	5310 MHz

2 channels are provided for 802.11ac (VHT80):

Channel	Frequency	Channel	Frequency
42	5210 MHz	58	5290 MHz

FOR 5500 ~ 5720 MHz

12 channels are provided for 802.11a, 802.11n (HT20), 802.11ac (VHT20):

Channel	Frequency	Channel	Frequency
100	5500 MHz	124	5620 MHz
104	5520 MHz	128	5640 MHz
108	5540 MHz	132	5660 MHz
112	5560 MHz	136	5680 MHz
116	5580 MHz	140	5700 MHz
120	5600 MHz	144	5720 MHz

6 channels are provided for 802.11n (HT40), 802.11ac (VHT40):

Channel	Frequency	Channel	Frequency
102	5510 MHz	126	5630 MHz
110	5550 MHz	134	5670 MHz
118	5590 MHz	142	5710 MHz

3 channels are provided for 802.11ac (VHT80):

Channel	Frequency	Channel	Frequency
106	5530 MHz	138	5690 MHz
122	5610 MHz		

FOR 5745 ~ 5825 MHz:

5 channels are provided for 802.11a, 802.11n (HT20), 802.11ac (VHT20):

Channel	Frequency	Channel	Frequency
149	5745 MHz	161	5805 MHz
153	5765 MHz	165	5825 MHz
157	5785 MHz		

2 channels are provided for 802.11n (HT40), 802.11ac (VHT40):

Channel	Frequency	Channel	Frequency
151	5755 MHz	159	5795 MHz

1 channel is provided for 802.11ac (VHT80):

Channel	Frequency
155	5775 MHz

3.4 Test Mode Applicability and Tested Channel Detail

Pre-Scan:	EUT can be used in the following ways: X-axis/ Y-axis/ Z-axis. Pre-scan in these ways and find the worst case as a representative test condition.
Worst Case:	Y-axis

Following channel(s) was (were) selected for the final test as listed below:

Test Item	Mode	Tested Channel	Modulation	Data Rate Parameter
AC Power Conducted Emissions	802.11a	116	BPSK	6Mb/s
Unwanted Emissions below 1 GHz	802.11a	116	BPSK	6Mb/s
Unwanted Emissions above 1 GHz	802.11a	36, 40, 48, 52, 60, 64, 100, 116, 140, 144, 149, 157, 165	BPSK	6Mb/s
	802.11n (HT20)	36, 40, 48, 52, 60, 64, 100, 116, 140, 144, 149, 157, 165	BPSK	MCS0
	802.11n (HT40)	38, 46, 54, 62, 102, 110, 134, 142, 151, 159	BPSK	MCS0
	802.11ac (VHT80)	42, 58, 106, 122, 138, 155	BPSK	MCS0
RF Output Power	802.11a	36, 40, 48, 52, 60, 64, 100, 116, 140, 144, 149, 157, 165	BPSK	6Mb/s
	802.11n (HT20)/ 802.11ac (VHT20)	36, 40, 48, 52, 60, 64, 100, 116, 140, 144, 149, 157, 165	BPSK	MCS0
	802.11n (HT40)/ 802.11ac (VHT40)	38, 46, 54, 62, 102, 110, 134, 142, 151, 159	BPSK	MCS0
	802.11ac (VHT80)	42, 58, 106, 122, 138, 155	BPSK	MCS0
Power Spectral Density	802.11a	36, 40, 48, 52, 60, 64, 100, 116, 140, 144, 149, 157, 165	BPSK	6Mb/s
	802.11n (HT20)	36, 40, 48, 52, 60, 64, 100, 116, 140, 144, 149, 157, 165	BPSK	MCS0
	802.11n (HT40)	38, 46, 54, 62, 102, 110, 134, 142, 151, 159	BPSK	MCS0
	802.11ac (VHT80)	42, 58, 106, 122, 138, 155	BPSK	MCS0
Occupied Bandwidth	802.11a	36, 40, 48, 52, 60, 64, 100, 116, 140, 144, 149, 157, 165	BPSK	6Mb/s
	802.11n (HT20)	36, 40, 48, 52, 60, 64, 100, 116, 140, 144, 149, 157, 165	BPSK	MCS0
	802.11n (HT40)	38, 46, 54, 62, 102, 110, 134, 142, 151, 159	BPSK	MCS0
	802.11ac (VHT80)	42, 58, 106, 122, 138, 155	BPSK	MCS0

Test Item	Mode	Tested Channel	Modulation	Data Rate Parameter
26 dB Bandwidth	802.11a	52, 60, 64, 100, 116, 140, 144	BPSK	6Mb/s
	802.11n (HT20)	52, 60, 64, 100, 116, 140, 144	BPSK	MCS0
	802.11n (HT40)	54, 62, 102, 110, 134, 142	BPSK	MCS0
	802.11ac (VHT80)	58, 106, 122, 138	BPSK	MCS0
6 dB Bandwidth	802.11a	144, 149, 157, 165	BPSK	6Mb/s
	802.11n (HT20)	144, 149, 157, 165	BPSK	MCS0
	802.11n (HT40)	142, 151, 159	BPSK	MCS0
	802.11ac (VHT80)	138, 155	BPSK	MCS0
Frequency Stability	802.11a	36	un-modulation	-

Note: Note: For unwanted emissions below 1 GHz and AC power conducted emission test items chosen the worst maximum power.

3.5 Duty Cycle of Test Signal

Duty cycle of test signal is $\geq 98\%$, duty factor is not required.
 Duty cycle of test signal is $< 98\%$, duty factor shall be considered.

802.11a: Duty cycle = $1.387 \text{ ms} / 1.454 \text{ ms} \times 100\% = 95.4\%$, duty factor = $10 * \log (1/\text{Duty cycle}) = 0.20 \text{ dB}$

802.11n (HT20): Duty cycle = $1.31 \text{ ms} / 1.357 \text{ ms} \times 100\% = 96.5\%$, duty factor = $10 * \log (1/\text{Duty cycle}) = 0.15 \text{ dB}$

802.11n (HT40): Duty cycle = $0.65 \text{ ms} / 0.697 \text{ ms} \times 100\% = 93.3\%$, duty factor = $10 * \log (1/\text{Duty cycle}) = 0.30 \text{ dB}$

802.11ac (VHT80): Duty cycle = $0.325 \text{ ms} / 0.367 \text{ ms} \times 100\% = 88.6\%$, duty factor = $10 * \log (1/\text{Duty cycle}) = 0.53 \text{ dB}$

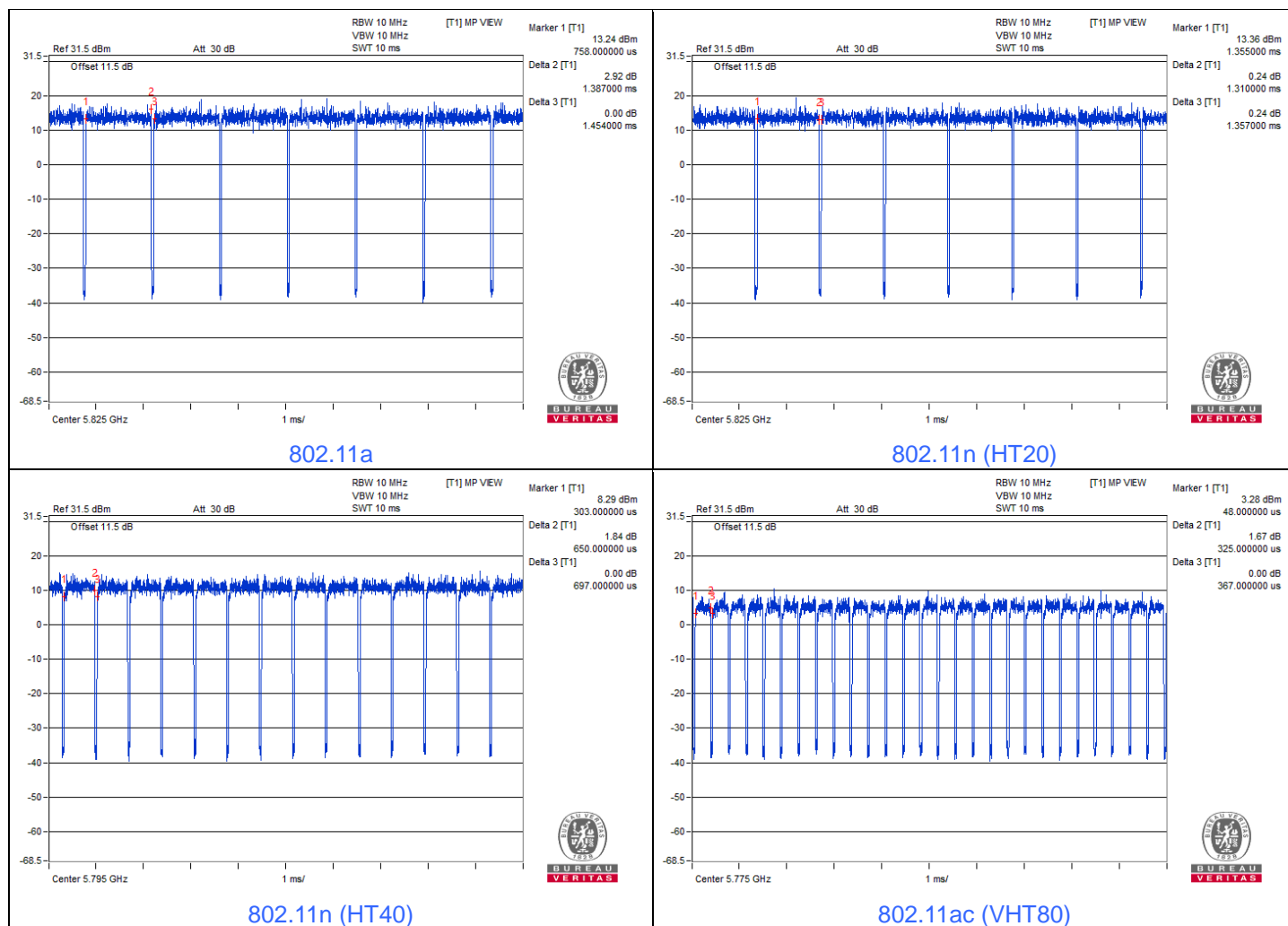

3.6 Description of Support Units

The EUT has been tested as an independent unit together with other necessary accessories or support units. The following support units or accessories were used to form a representative test configuration during the tests.

ID	Product	Brand	Model No.	Serial No.	FCC ID	Remarks
A.	Earphone	Funkey	FK-130102	NA	N/A	Supplied by applicant

ID	Descriptions	Qty.	Length (m)	Shielding (Yes/No)	Cores (Qty.)	Remarks
1.	USB Cable	1	1	No	0	Accessory of the EUT
2.	Earphone Cable	1	1	No	0	Supplied by applicant

Note: The core(s) is(are) originally attached to the cable(s).

3.6.1 Configuration of System under Test

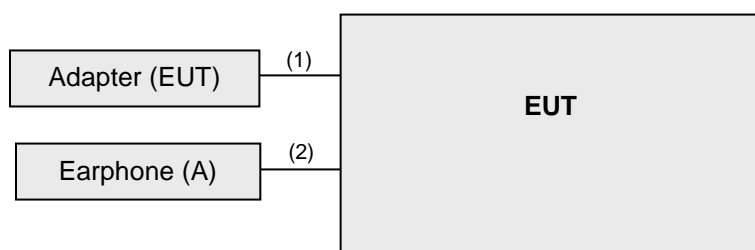

4 Test Instruments

The calibration interval of the all test instruments are 12 months and the calibrations are traceable to NML/ROC and NIST/USA.

4.1 26 dB Bandwidth

Description Manufacturer	Model No.	Serial No.	Calibrated Date	Calibrated Until
Software BV	ADT_RF Test Software V6.6.5.4	N/A	N/A	N/A
Spectrum Analyzer R&S	FSV40	100979	2022/3/25	2023/3/24

Notes:

1. The test was performed in Oven room.
2. Tested Date: 2022/6/7 ~ 2022/10/6

4.2 RF Output Power

Description Manufacturer	Model No.	Serial No.	Calibrated Date	Calibrated Until
Peak Power Analyzer KEYSIGHT	8990B	MY51000485	2022/1/18	2023/1/17
Power sensor Keysight	U2021XA	MY55380009	2022/3/23	2023/3/22
Software BV	ADT_RF Test Software V6.6.5.4	N/A	N/A	N/A
Spectrum Analyzer R&S	FSV40	100979	2022/3/25	2023/3/24
Wideband Power Sensor(N1923A) KEYSIGHT	N1923A	MY58020002	2022/1/17	2023/1/16

Notes:

1. The test was performed in Oven room.
2. Tested Date: 2022/6/7 ~ 2022/10/6

4.3 Power Spectral Density

Refer to section 4.1 to get information of the instruments.

4.4 6 dB Bandwidth

Refer to section 4.1 to get information of the instruments.

4.5 Occupied Bandwidth

Refer to section 4.1 to get information of the instruments.

4.6 Frequency Stability

Description Manufacturer	Model No.	Serial No.	Calibrated Date	Calibrated Until
3-channel DC power supply JIN YIH Technology	ODP3033	ODP30332128138	N/A	N/A
Digital Multimeter Fluke	87-III	70360755	2022/7/7	2023/7/6
Software BV	ADT_RF Test Software V6.6.5.4	N/A	N/A	N/A
Spectrum Analyzer R&S	FSV40	100979	2022/3/25	2023/3/24
Temperature & Humidity Chamber TERCHY	HRM-120RF	931022	2022/1/3	2023/1/2

Notes:

1. The test was performed in Oven room.
2. Tested Date: 2022/10/6

4.7 AC Power Conducted Emissions

Description Manufacturer	Model No.	Serial No.	Calibrated Date	Calibrated Until
DC LISN R&S	ESH3-Z6	100219	2021/7/25	2022/7/24
		844950/018	2021/7/25	2022/7/24
DC-LISN SCHWARZBECK MESS- ELETRONIK	NNBM 8126G	8126G-069	2021/11/10	2022/11/9
LISN R&S	ESH2-Z5	100100	2022/2/17	2023/2/16
	ESH3-Z5	100312	2021/9/17	2022/9/16
	ENV216	100072	2021/6/16	2022/6/15
RF Coaxial Cable WORKEN	5D-FB	Cable-cond2-01	2021/9/4	2022/9/3
Software BVADT	BVADT_Cond_ V7.3.7.4	N/A	N/A	N/A
Test Receiver R&S	ESR3	102783	2021/12/20	2022/12/19
V-LISN Schwarzbeck	NNBL 8226-2	8226-142	2021/8/20	2022/8/19

Notes:

1. The test was performed in HY - Conduction 2.
2. Tested Date: 2022/6/9

4.8 Unwanted Emissions below 1 GHz

Description Manufacturer	Model No.	Serial No.	Calibrated Date	Calibrated Until
Antenna Tower Max-Full	UNAT_5+	PAD-CH6-01	N/A	N/A
Antenna Tower Controller Max-Full	MF-7802	N/A	N/A	N/A
Bi_Log Antenna Schwarzbeck	VULB9168	9168-616	2021/10/27	2022/10/26
Loop Antenna TESEQ	HLA 6121	45745	2021/7/21	2022/7/20
Loop Antenna EMCI	EM-6879	269	2021/9/16	2022/9/15
Preamplifier Agilent	310N	187226	2021/6/17	2022/6/16
Pre-amplifier EMCI	EMC001340	980201	2021/9/15	2022/9/14
RF Coaxial Cable EMCI	5D-NM-BM	140903+140902	2022/1/15	2023/1/14
RF Coaxial Cable ETS-Lindgren	EMC104-SM-SM-10000	Cable-CH1-01(RFC-SMS-100-SMS-120+RFC-SMS-100-SMS-4	2021/6/17	2022/6/16
	RFC-SMS-100-SMS-24-IN	Cable-CH1-02(RFC-SMS-100-SMS-24)	2021/6/17	2022/6/16
Software BV ADT	ADT_Radiated_V7.6.15.9.5	N/A	N/A	N/A
Test Receiver Agilent	N9038A	MY52260177	2021/9/1	2022/8/31
Turn Table Max-Full	TT-1510	N/A	N/A	N/A
Turn Table Controller Max-Full	MF-7802	N/A	N/A	N/A

Notes:

1. The test was performed in XD - 966 chamber 6.
2. Tested Date: 2022/6/2

4.9 Unwanted Emissions above 1 GHz

Description Manufacturer	Model No.	Serial No.	Calibrated Date	Calibrated Until
Antenna Tower Max-Full	UNAT_5+	PAD-CH6-01	N/A	N/A
Antenna Tower Controller Max-Full	MF-7802	N/A	N/A	N/A
Boresight antenna tower fixture BV	BAF-02	8	N/A	N/A
Horn Antenna ETS-Lindgren	3117	00143293	2021/11/14	2022/11/13
Horn Antenna Schwarzbeck	BBHA 9170	BBHA9170241	2021/10/26	2022/10/25
Pre-Amplifier EMCI	EMC 184045	980116	2021/10/5	2022/10/4
			2022/10/1	2023/9/30
Preamplifier Agilent	83017A	MY39501373	2021/6/17	2022/6/16
			2022/6/14	2023/6/13
RF Coaxial Cable ETS-Lindgren	EMC104-SM-SM-10000	Cable-CH1-01(RFC-SMS-100-SMS-120+RFC-SMS-100-SMS-4	2021/6/17	2022/6/16
			2022/6/14	2023/6/13
	RFC-SMS-100-SMS-24-IN	Cable-CH1-02(RFC-SMS-100-SMS-24)	2021/6/17	2022/6/16
			2022/6/14	2023/6/13
RF Coaxial Cable HUBER+SUHNER&EMCI	SUCOFLEX 104& EMC104-SM-SM8000	CABLE-CH9-02 (248780+171006)	2022/1/15	2023/1/14
RF Coaxial Cable HUBER+SUHNER	SUCOFLEX 104	CABLE-CH9-(250795/4)	2022/1/15	2023/1/14
Software BV ADT	ADT_Radiated_ V7.6.15.9.5	N/A	N/A	N/A
Test Receiver Agilent	N9038A	MY52260177	2021/9/1	2022/8/31
			2022/9/19	2023/9/18
Turn Table Max-Full	TT-1510	N/A	N/A	N/A
Turn Table Controller Max-Full	MF-7802	N/A	N/A	N/A

Notes:

1. The test was performed in XD - 966 chamber 6.
2. Tested Date: 2022/5/20 ~ 2022/10/5

5 Limits of Test Items

5.1 26 dB Bandwidth

The results are for reference only.

5.2 RF Output Power

Operation Band	EUT Category	Limit
U-NII-1	Outdoor Access Point	1 Watt (30 dBm) (Max. e.i.r.p \leq 125mW(21 dBm) at any elevation angle above 30 degrees as measured from the horizon)
	Fixed point-to-point Access Point	1 Watt (30 dBm)
	Indoor Access Point	1 Watt (30 dBm)
	Mobile and Portable client device	250mW (24 dBm)

Operation Band	Limit
U-NII-2A	250mW (24 dBm) or 11 dBm+10 log B*
U-NII-2C	250mW (24 dBm) or 11 dBm+10 log B*
U-NII-3	1 Watt (30 dBm)

*B is the 26 dB emission bandwidth in megahertz

5.3 Power Spectral Density

Operation Band	EUT Category	Limit
U-NII-1	Outdoor Access Point	17 dBm/ MHz
	Fixed point-to-point Access Point	
	Indoor Access Point	
	Mobile and Portable client device	11 dBm/ MHz

Operation Band	Limit
U-NII-2A	11 dBm/ MHz
U-NII-2C	11 dBm/ MHz
U-NII-3	30 dBm/ 500 kHz

5.4 6 dB Bandwidth

Within the 5.725-5.850 GHz band, the minimum 6 dB bandwidth of U-NII devices shall be at least 500 kHz.

5.5 Occupied Bandwidth

The results are for reference only.

5.6 Frequency Stability

The frequency of the carrier signal shall be maintained within band of operation.

5.7 AC Power Conducted Emissions

Frequency (MHz)	Conducted Limit (dBuV)	
	Quasi-peak	Average
0.15 - 0.5	66 - 56	56 - 46
0.50 - 5.0	56	46
5.0 - 30.0	60	50

Notes:

1. The lower limit shall apply at the transition frequencies.
2. The limit decreases in line with the logarithm of the frequency in the range of 0.15 to 0.50 MHz.

5.8 Unwanted Emissions below 1 GHz

Radiated emissions which fall in the restricted bands must comply with the radiated emission limits specified as below table.

Frequencies (MHz)	Field Strength (microvolts/meter)	Measurement Distance (meters)
0.009 ~ 0.490	2400/F(kHz)	300
0.490 ~ 1.705	24000/F(kHz)	30
1.705 ~ 30.0	30	30
30 ~ 88	100	3
88 ~ 216	150	3
216 ~ 960	200	3
Above 960	500	3

Notes:

1. The lower limit shall apply at the transition frequencies.
2. Emission level (dBuV/m) = 20 log Emission level (uV/m).

5.9 Unwanted Emissions above 1 GHz

Radiated emissions which fall in the restricted bands must comply with the radiated emission limits specified as below table.

Frequencies (MHz)	Field Strength (microvolts/meter)	Measurement Distance (meters)
Above 960	500	3

Notes:

1. The lower limit shall apply at the transition frequencies.
2. Emission level (dBuV/m) = 20 log Emission level (uV/m).
3. For frequencies above 1000 MHz, the field strength limits are based on average detector, however, the peak field strength of any emission shall not exceed the maximum permitted average limits, specified above by more than 20 dB under any condition of modulation.

Limits of unwanted emission out of the restricted bands

Applicable To		Limit	
789033 D02 General UNII Test Procedure New Rules v02r01		Field Strength at 3 m	
		PK: 74 (dBµV/m)	AV: 54 (dBµV/m)
Frequency Band	Applicable To	EIRP Limit	Equivalent Field Strength at 3 m
5150~5250 MHz	15.407(b)(1)	PK: -27 (dBm/MHz)	PK: 68.2 (dBµV/m)
5250~5350 MHz	15.407(b)(2)		
5470~5725 MHz	15.407(b)(3)		
5725~5850 MHz	15.407(b)(4)(i)	PK: -27 (dBm/MHz) ^{*1} PK: 10 (dBm/MHz) ^{*2} PK: 15.6 (dBm/MHz) ^{*3} PK: 27 (dBm/MHz) ^{*4}	PK: 68.2 (dBµV/m) ^{*1} PK: 105.2 (dBµV/m) ^{*2} PK: 110.8 (dBµV/m) ^{*3} PK: 122.2 (dBµV/m) ^{*4}
*1 beyond 75 MHz or more above of the band edge.		*2 below the band edge increasing linearly to 10 dBm/MHz at 25 MHz above.	
*3 below the band edge increasing linearly to a level of 15.6 dBm/MHz at 5 MHz above.		*4 from 5 MHz above or below the band edge increasing linearly to a level of 27 dBm/MHz at the band edge.	

Note: The following formula is used to convert the equipment isotropic radiated power (eirp) to field strength:

$$E = \frac{1000000\sqrt{30P}}{3} \mu\text{V/m, where P is the eirp (Watts).}$$

6 Test Arrangements

6.1 26 dB Bandwidth

6.1.1 Test Setup

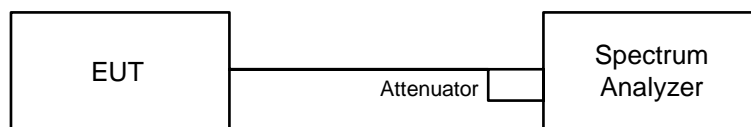

6.1.2 Test Procedure

- a. Set RBW = approximately 1% of the emission bandwidth.
- b. Set the VBW > RBW.
- c. Detector = Peak.
- d. Trace mode = max hold.
- e. Measure the maximum width of the emission that is 26 dB down from the peak of the emission. Compare this with the RBW setting of the analyzer. Readjust RBW and repeat measurement as needed until the RBW/EBW ratio is approximately 1%.

6.2 RF Output Power

6.2.1 Test Setup

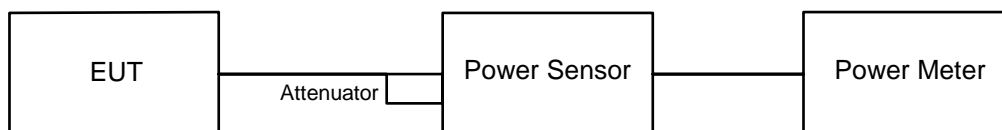

For channel straddling:

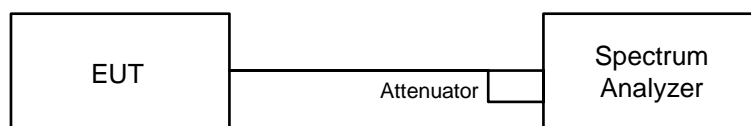

6.2.2 Test Procedure

Method PM is used to perform output power measurement, trigger and gating function of wide band power meter is enabled to measure max output power of TX on burst and set the detector to average. Duty factor is not added to measured value.

For channel straddling:

Method SA-2A

- Set span to encompass the entire emission bandwidth (EBW) of the signal.
- Set RBW = 1 MHz, Set VBW \geq 3 MHz, Detector = RMS
- Sweep points $\geq [2 \times \text{span} / \text{RBW}]$. (This gives bin-to-bin spacing $\leq \text{RBW} / 2$, so that narrowband signals are not lost between frequency bins.)
- Manually set sweep time $\geq 10 \times (\text{number of points in sweep}) \times (\text{total on/off period of the transmitted signal})$.
- Perform a single sweep.
- Record the max value and add $10 \log (1/\text{duty cycle})$.

Note: When measuring straddle channel power, use compute power by integrating the spectrum across the 26 dB EBW or 99% OBW of the signal using the instrument's band power measurement function, with band limits set equal to the EBW or OBW band edges. If the instrument does not have a band power function, then sum the spectrum levels (in power units) at 1 MHz intervals extending across the 26 dB EBW or 99% OBW of the spectrum.

6.3 Power Spectral Density

6.3.1 Test Setup

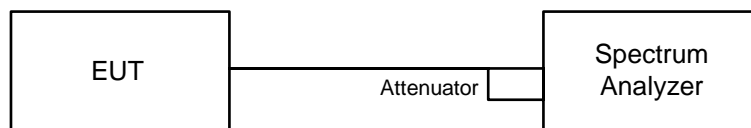

6.3.2 Test Procedure

For specified measurement bandwidth 1 MHz:

Method SA-2

- g. Set span to encompass the entire emission bandwidth (EBW) of the signal.
- h. Set RBW = 1 MHz, Set VBW \geq 3 MHz, Detector = RMS
- i. Sweep points \geq $[2 \times \text{span} / \text{RBW}]$. (This gives bin-to-bin spacing \leq RBW / 2, so that narrowband signals are not lost between frequency bins.)
- j. Sweep time = auto, trigger set to "free run".
- k. Trace average at least 100 traces in power averaging mode.
- l. Use the peak search function on the instrument to find the peak of the spectrum and record its value.
- m. Record the max value and add 10 log (1/duty cycle).

For specified measurement bandwidth 500 kHz:

Method SA-2

- a. Set span to encompass the entire emission bandwidth (EBW) of the signal.
- b. Set RBW = 300 kHz, Set VBW \geq 1 MHz, Detector = RMS
- c. Scale the observed power level to an equivalent value in 500 kHz by adjusting (increasing) the measured power by a bandwidth correction factor (BWCF) where $\text{BWCF} = 10\log(500 \text{ kHz}/300 \text{ kHz})$
- d. Sweep points \geq $[2 \times \text{span} / \text{RBW}]$. (This gives bin-to-bin spacing \leq RBW / 2, so that narrowband signals are not lost between frequency bins.)
- e. Sweep time = auto, trigger set to "free run".
- f. Trace average at least 100 traces in power averaging mode.
- g. Use the peak search function on the instrument to find the peak of the spectrum and record its value.
- h. Record the max value and add 10 log (1/duty cycle).

6.4 6 dB Bandwidth

6.4.1 Test Setup

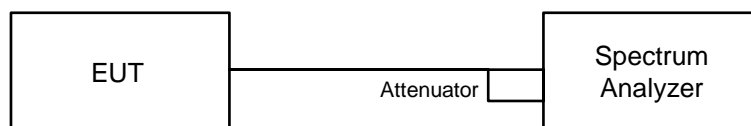

6.4.2 Test Procedure

- a. Set resolution bandwidth (RBW) = 100 kHz.
- b. Set the video bandwidth (VBW) \geq 3 x RBW, Detector = Peak.
- c. Trace mode = max hold.
- d. Sweep = auto couple.
- e. Measure the maximum width of the emission that is constrained by the frequencies associated with the two amplitude points (upper and lower) that are attenuated by 6 dB relative to the maximum level measured in the fundamental emission.

6.5 Occupied Bandwidth

6.5.1 Test Setup

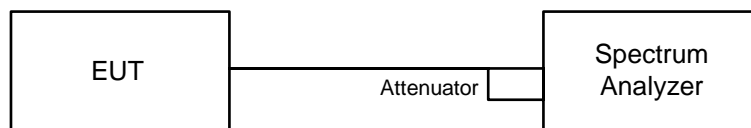

6.5.2 Test Procedure

The transmitter output was connected to the spectrum analyzer through an attenuator. The bandwidth of the fundamental frequency was measured by spectrum analyzer with resolution bandwidth in the range of 1% to 5% of the anticipated emission bandwidth, and a video bandwidth at least 3x the resolution bandwidth and set the detector to Sampling. The width of a frequency band such that, below the lower and above the upper frequency limits, the mean powers emitted are each equal to a specified percentage 0.5% of the total mean power of a given emission.

6.6 Frequency Stability

6.6.1 Test Setup

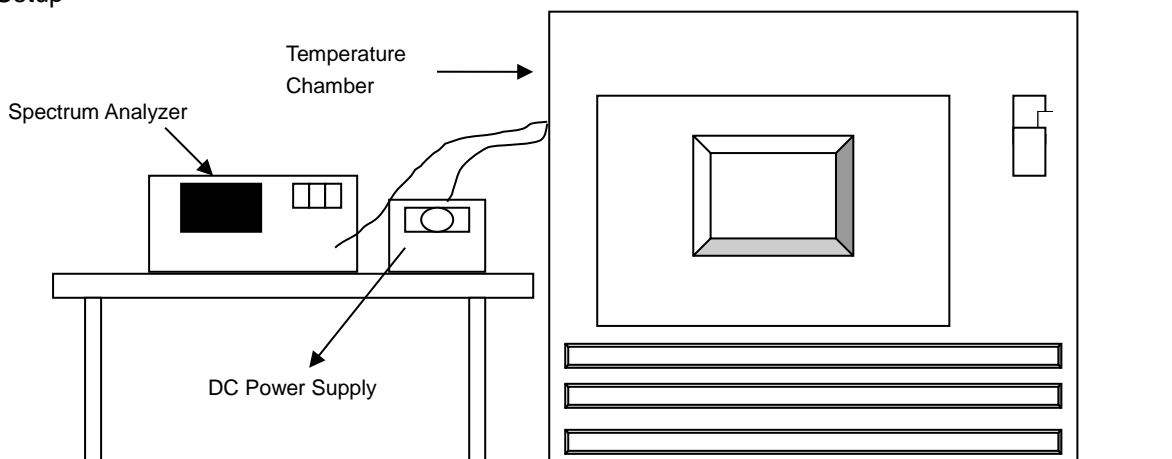

6.6.2 Test Procedure

- The EUT was placed inside the environmental test chamber and powered by nominal DC voltage.
- Turn the EUT on and couple its output to a spectrum analyzer.
- Turn the EUT off and set the chamber to the highest temperature specified.
- Allow sufficient time (approximately 30 min) for the temperature of the chamber to stabilize, turn the EUT on and measure the operating frequency after 2, 5, and 10 Minutes.
- Repeat step (d) with the temperature chamber set to the next desired temperature until measurements down to the lowest specified temperature have been completed.
- The test chamber was allowed to stabilize at +20 degree C for a minimum of 30 Minutes. The supply voltage was then adjusted on the EUT from 85% to 115% and the frequency record.

6.7 AC Power Conducted Emissions

6.7.1 Test Setup

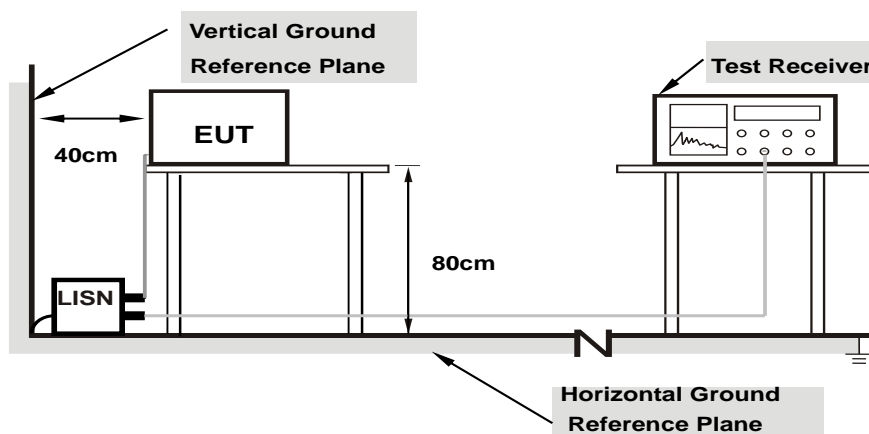

Note: 1.Support units were connected to second LISN.

For the actual test configuration, please refer to the attached file (Test Setup Photo).

6.7.2 Test Procedure

- The EUT was placed 0.4 meters from the conducting wall of the shielded room with EUT being connected to the power mains through a line impedance stabilization network (LISN). Other support units were connected to the power mains through another LISN. The two LISNs provide 50 ohm/ 50 uH of coupling impedance for the measuring instrument.
- Both lines of the power mains connected to the EUT were checked for maximum conducted interference.
- The frequency range from 150 kHz to 30 MHz was searched. Emission levels under (Limit – 20 dB) was not recorded.

Note:

The resolution bandwidth and video bandwidth of test receiver is 9 kHz for quasi-peak detection (QP) and average detection (AV) at frequency 0.15 MHz-30 MHz.

6.8 Unwanted Emissions below 1 GHz

6.8.1 Test Setup

For Radiated emission below 30 MHz

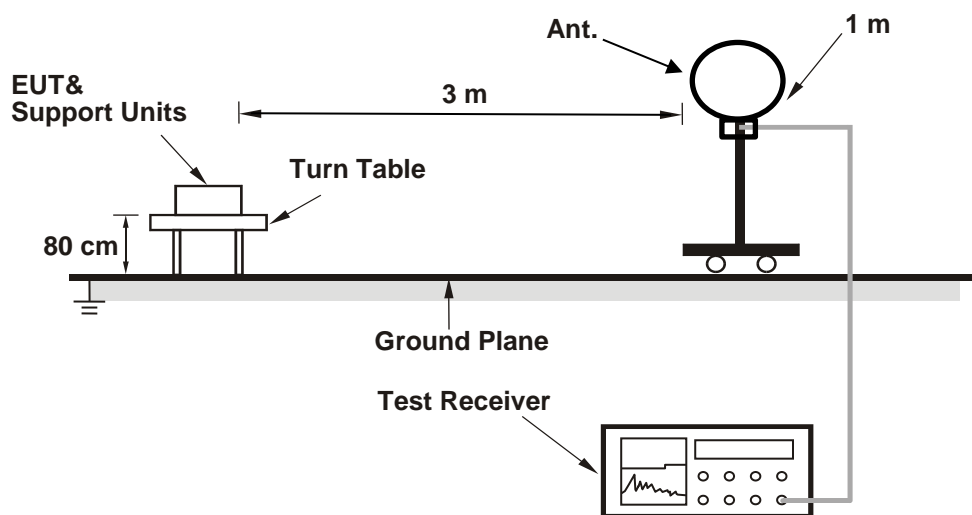

For Radiated emission above 30 MHz

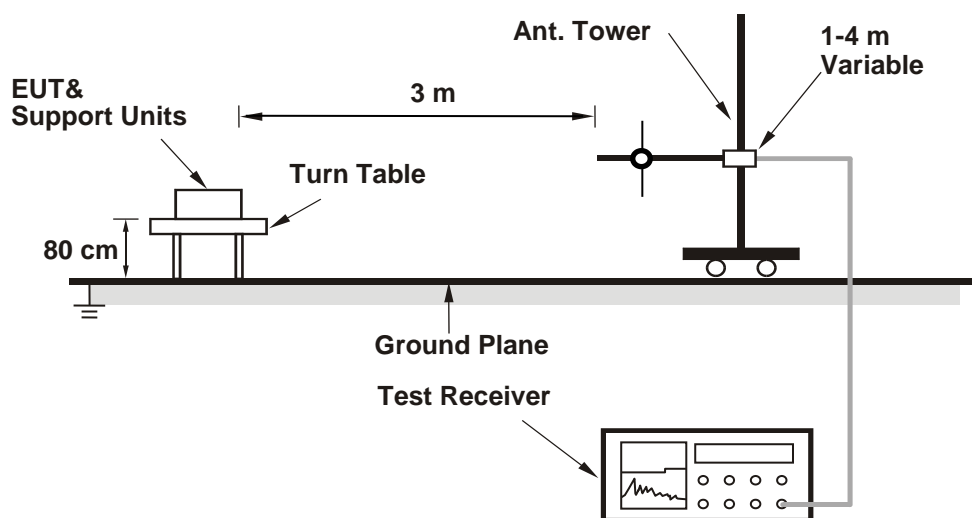

6.8.2 Test Procedure

For Radiated emission below 30 MHz

- a. The EUT was placed on the top of a rotating table 0.8 meters above the ground at 3 meter chamber room for test. The table was rotated 360 degrees to determine the position of the highest radiation.
- b. The EUT was set 3 meters away from the interference-receiving antenna, which was mounted on the top of a variable-height antenna tower.
- c. Parallel, perpendicular, and ground-parallel orientations of the antenna are set to make the measurement.
- d. For each suspected emission, the EUT was arranged to its worst case and the rotatable table was turned from 0 degrees to 360 degrees to find the maximum reading.
- e. The test-receiver system was set to Quasi-Peak Detect Function and Specified Bandwidth with Maximum Hold Mode.

Notes:

1. The resolution bandwidth and video bandwidth of test receiver/spectrum analyzer is 9 kHz at frequency below 30 MHz.
2. All modes of operation were investigated and the worst-case emissions are reported.

For Radiated emission above 30 MHz

- a. The EUT was placed on the top of a rotating table 0.8 meters above the ground at 3 meter chamber room for test. The table was rotated 360 degrees to determine the position of the highest radiation.
- b. The EUT was set 3 meters away from the interference-receiving antenna, which was mounted on the top of a variable-height antenna tower.
- c. The height of antenna is varied from one meter to four meters above the ground to determine the maximum value of the field strength. Both horizontal and vertical polarizations of the antenna are set to make the measurement.
- d. For each suspected emission, the EUT was arranged to its worst case and then the antenna was tuned to heights from 1 meter to 4 meters and the rotatable table was turned from 0 degrees to 360 degrees to find the maximum reading.
- e. The test-receiver system was set to quasi-peak detect function and specified bandwidth with maximum hold mode when the test frequency is below 1 GHz.

Notes:

1. The resolution bandwidth and video bandwidth of test receiver/spectrum analyzer is 120 kHz for Quasi-peak detection (QP) at frequency below 1 GHz.
2. All modes of operation were investigated and the worst-case emissions are reported.

6.9 Unwanted Emissions above 1 GHz

6.9.1 Test Setup

For Radiated emission above 1 GHz

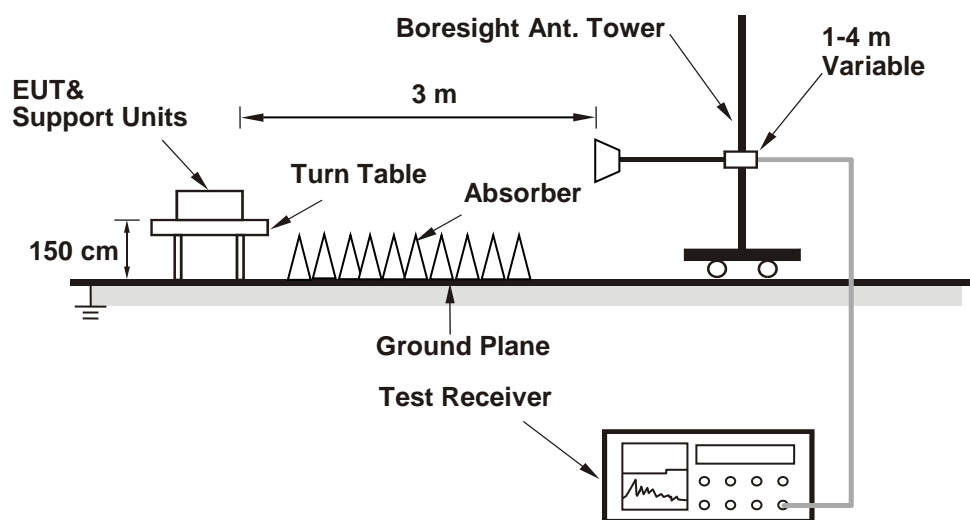

For the actual test configuration, please refer to the attached file (Test Setup Photo).

6.9.2 Test Procedure

- The EUT was placed on the top of a rotating table 1.5 meters above the ground at 3 meter chamber room for test. The table was rotated 360 degrees to determine the position of the highest radiation.
- The EUT was set 3 meters away from the interference-receiving antenna, which was mounted on the top of a variable-height antenna tower.
- The height of antenna is varied from one meter to four meters above the ground to determine the maximum value of the field strength. Both horizontal and vertical polarizations of the antenna are set to make the measurement.
- For each suspected emission, the EUT was arranged to its worst case and then the antenna was tuned to heights from 1 meter to 4 meters and the rotatable table was turned from 0 degrees to 360 degrees to find the maximum reading.
- The test-receiver system was set to peak and average detects function and specified bandwidth with maximum hold mode when the test frequency is above 1 GHz. If the peak reading value also meets average limit, measurement with the average detector is unnecessary.

Notes:

- The resolution bandwidth of test receiver/spectrum analyzer is 1 MHz and the video bandwidth is 3 MHz for Peak detection (PK) and Average detection (AV) at frequency above 1 GHz.
- For fundamental and harmonic signal measurement, the resolution bandwidth of test receiver/spectrum analyzer is 1 MHz and the video bandwidth is $\geq 1/T$ (Duty cycle $< 98\%$) or 10 Hz (Duty cycle $\geq 98\%$) for Average detection (AV) at frequency above 1 GHz.
- All modes of operation were investigated and the worst-case emissions are reported.

7 Test Results of Test Item

7.1 26 dB Bandwidth

Input Power:	3.8 Vdc	Environmental Conditions:	25°C, 60% RH	Tested By:	Chun Wu
--------------	---------	---------------------------	--------------	------------	---------

802.11a

Channel	Frequency (MHz)	26dB Bandwidth (MHz)
52	5260	20.44
60	5300	25.87
64	5320	20.22
100	5500	20.38
116	5580	26.89
140	5700	22.4
144 (U-NII-2C)	5720	15.18
144 (U-NII-3)	5720	5.15

Determined Output Power Limit			
Channel Number	Freq.(MHz)	Min. B(MHz)	Determined Conducted Power Limit (dBm)
52	5260	20.44	24.1 > 24
60	5300	25.87	25.12 > 24
64	5320	20.22	24.05 > 24
100	5500	20.38	24.09 > 24
116	5580	26.89	25.29 > 24
140	5700	22.40	24.5 > 24
144 (U-NII-2C)	5720	15.18	22.81 < 24

Note: For U-NII-2A, U-NII-2C Band output power limitation is determined based on 26dBc bandwidth.

802.11n (HT20)

Channel	Frequency (MHz)	26dB Bandwidth (MHz)
52	5260	25.46
60	5300	25.51
64	5320	20.9
100	5500	20.85
116	5580	29.38
140	5700	20.62
144 (U-NII-2C)	5720	15.37
144 (U-NII-3)	5720	5.33

Determined Output Power Limit			
Channel Number	Freq.(MHz)	Min. B(MHz)	Determined Conducted Power Limit (dBm)
52	5260	25.46	25.05 > 24
60	5300	25.51	25.06 > 24
64	5320	20.90	24.2 > 24
100	5500	20.85	24.19 > 24
116	5580	29.38	25.68 > 24
140	5700	20.62	24.14 > 24
144 (U-NII-2C)	5720	15.37	22.86 < 24

Note: For U-NII-2A, U-NII-2C Band output power limitation is determined based on 26dBc bandwidth.

802.11n (HT40)

Channel	Frequency (MHz)	26dB Bandwidth (MHz)
54	5270	44.54
62	5310	41.82
102	5510	42.15
110	5550	60.29
134	5670	41.74
142 (U-NII-2C)	5710	42.61
142 (U-NII-3)	5710	13.46

Determined Output Power Limit

Channel Number	Freq.(MHz)	Min. B(MHz)	Determined Conducted Power Limit (dBm)	
54	5270	44.54	27.48	> 24
62	5310	41.82	27.21	> 24
102	5510	42.15	27.24	> 24
110	5550	60.29	28.8	> 24
134	5670	41.74	27.2	> 24
142 (U-NII-2C)	5710	42.61	27.29	> 24

Note: For U-NII-2A, U-NII-2C Band output power limitation is determined based on 26dBc bandwidth.

802.11ac (VHT80)

Channel	Frequency (MHz)	26dB Bandwidth (MHz)
58	5290	81.98
106	5530	82.1
122	5610	81.43
138 (U-NII-2C)	5690	76.33
138 (U-NII-3)	5690	6.11

Determined Output Power Limit

Channel Number	Freq.(MHz)	Min. B(MHz)	Determined Conducted Power Limit (dBm)	
58	5290	81.98	30.13	> 24
106	5530	82.10	30.14	> 24
122	5610	81.43	30.1	> 24
138 (U-NII-2C)	5690	76.33	29.82	> 24

Note: For U-NII-2A, U-NII-2C Band output power limitation is determined based on 26dBc bandwidth.



Spectrum Plot of Minimum Value

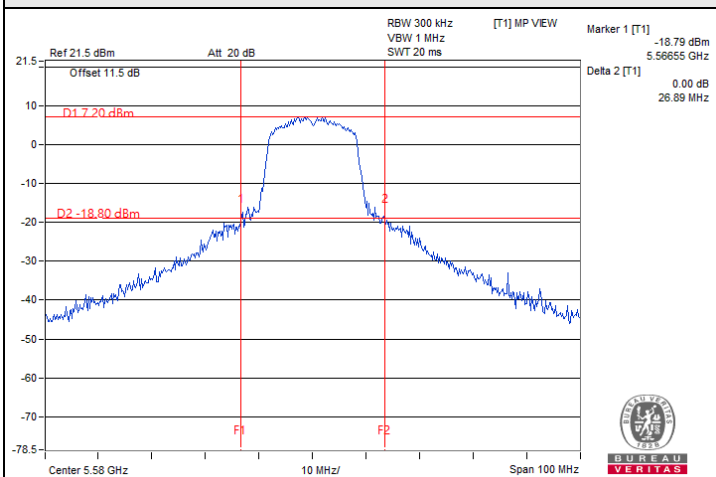

802.11a : CH 116

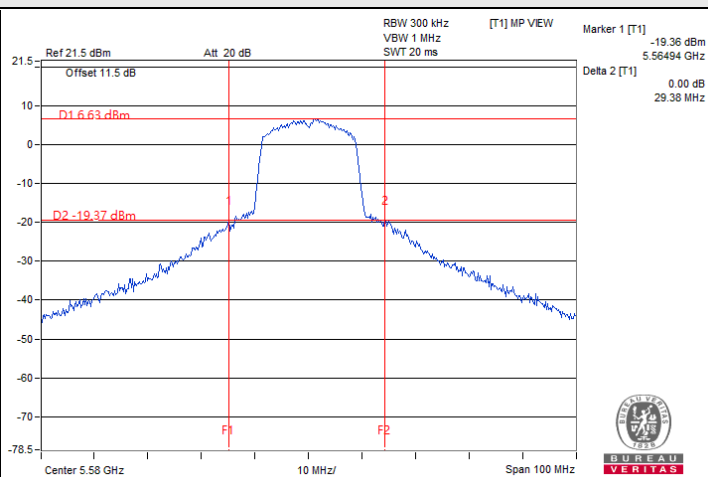

802.11n (HT20) : CH 116

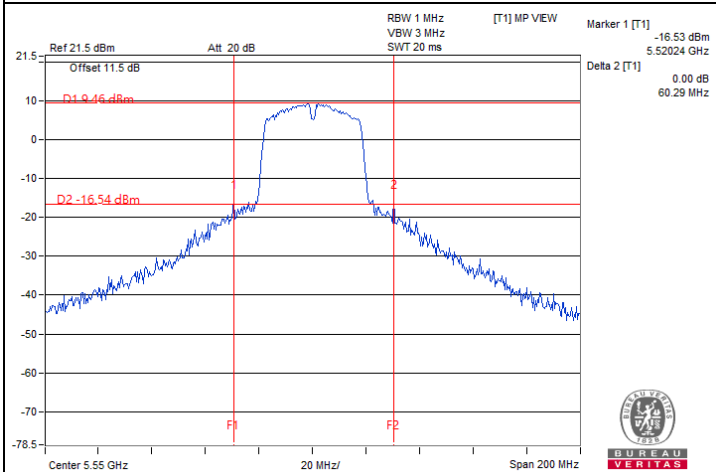

802.11n (HT40) : CH 110

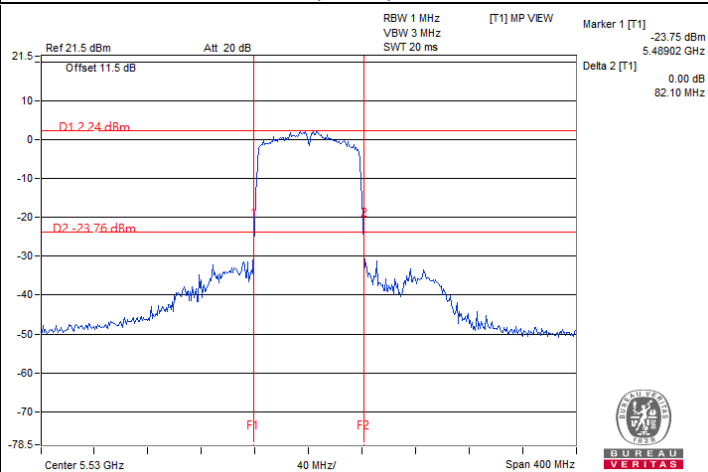

802.11ac (VHT80) : CH 106

7.2 RF Output Power

Input Power:	3.8 Vdc	Environmental Conditions:	25°C, 60% RH	Tested By:	Chun Wu
--------------	---------	---------------------------	--------------	------------	---------

802.11a

Chan.	Chan. Freq. (MHz)	Average Power (mW)	Average Power (dBm)	Power Limit (dBm)	Test Result
36	5180	25.235	14.02	24	Pass
40	5200	36.141	15.58	24	Pass
48	5240	33.884	15.30	24	Pass
52	5260	34.995	15.44	24	Pass
60	5300	34.754	15.41	24	Pass
64	5320	25.235	14.02	24	Pass
100	5500	20.845	13.19	24	Pass
116	5580	36.475	15.62	24	Pass
140	5700	19.364	12.87	24	Pass
*144 (U-NII-2C)	5720	13.32	11.25	22.81	Pass
*144 (U-NII-3)	5720	2.267	3.55	30	Pass
149	5745	19.32	12.86	30	Pass
157	5785	35.481	15.50	30	Pass
165	5825	19.907	12.99	30	Pass

Notes:

1. For U-NII-1, the antenna gain is 3.79 dBi < 6 dBi, so the output power limit shall not be reduced.
2. For U-NII-2A, the antenna gain is 3.79 dBi < 6 dBi, so the output power limit shall not be reduced.
3. For U-NII-2C, the antenna gain is 3.79 dBi < 6 dBi, so the output power limit shall not be reduced.
4. For U-NII-3, the antenna gain is 3.79 dBi < 6 dBi, so the output power limit shall not be reduced.

* Test was performed in accordance with measurement follow FCC KDB 789033 UNII test procedure Method SA-2A and use spectrum analyzer test, the duty factor was included in the total power.

802.11n (HT20)

Chan.	Chan. Freq. (MHz)	Average Power (mW)	Average Power (dBm)	Power Limit (dBm)	Test Result
36	5180	24.889	13.96	24	Pass
40	5200	31.55	14.99	24	Pass
48	5240	32.137	15.07	24	Pass
52	5260	30.903	14.90	24	Pass
60	5300	30.62	14.86	24	Pass
64	5320	25.003	13.98	24	Pass
100	5500	18.923	12.77	24	Pass
116	5580	30.549	14.85	24	Pass
140	5700	19.055	12.80	24	Pass
*144 (U-NII-2C)	5720	13.974	11.45	22.86	Pass
*144 (U-NII-3)	5720	2.663	4.25	30	Pass
149	5745	20.701	13.16	30	Pass
157	5785	31.842	15.03	30	Pass
165	5825	19.77	12.96	30	Pass

Notes:

1. For U-NII-1, the antenna gain is 3.79 dBi < 6 dBi, so the output power limit shall not be reduced.
 2. For U-NII-2A, the antenna gain is 3.79 dBi < 6 dBi, so the output power limit shall not be reduced.
 3. For U-NII-2C, the antenna gain is 3.79 dBi < 6 dBi, so the output power limit shall not be reduced.
 4. For U-NII-3, the antenna gain is 3.79 dBi < 6 dBi, so the output power limit shall not be reduced.
- * Test was performed in accordance with measurement follow FCC KDB 789033 UNII test procedure Method SA-2A and use spectrum analyzer test, the duty factor was included in the total power.

802.11n (HT40)

Chan.	Chan. Freq. (MHz)	Average Power (mW)	Average Power (dBm)	Power Limit (dBm)	Test Result
38	5190	11.885	10.75	24	Pass
46	5230	32.434	15.11	24	Pass
54	5270	29.854	14.75	24	Pass
62	5310	10.423	10.18	24	Pass
102	5510	9.705	9.87	24	Pass
110	5550	30.2	14.80	24	Pass
134	5670	30.339	14.82	24	Pass
*142 (U-NII-2C)	5710	25.37	14.04	24	Pass
*142 (U-NII-3)	5710	1.414	1.50	30	Pass
151	5755	19.77	12.96	30	Pass
159	5795	19.409	12.88	30	Pass

Notes:

1. For U-NII-1, the antenna gain is 3.79 dBi < 6 dBi, so the output power limit shall not be reduced.
 2. For U-NII-2A, the antenna gain is 3.79 dBi < 6 dBi, so the output power limit shall not be reduced.
 3. For U-NII-2C, the antenna gain is 3.79 dBi < 6 dBi, so the output power limit shall not be reduced.
 4. For U-NII-3, the antenna gain is 3.79 dBi < 6 dBi, so the output power limit shall not be reduced.
- * Test was performed in accordance with measurement follow FCC KDB 789033 UNII test procedure Method SA-2A and use spectrum analyzer test, the duty factor was included in the total power.

802.11ac (VHT20)

Chan.	Chan. Freq. (MHz)	Average Power (mW)	Average Power (dBm)	Power Limit (dBm)	Test Result
36	5180	24.21	13.84	24	Pass
40	5200	29.04	14.63	24	Pass
48	5240	30.479	14.84	24	Pass
52	5260	30.2	14.80	24	Pass
60	5300	28.314	14.52	24	Pass
64	5320	23.823	13.77	24	Pass
100	5500	17.947	12.54	24	Pass
116	5580	28.708	14.58	24	Pass
140	5700	18.113	12.58	24	Pass
*144 (U-NII-2C)	5720	13.687	11.36	22.86	Pass
*144 (U-NII-3)	5720	2.608	4.16	30	Pass
149	5745	19.409	12.88	30	Pass
157	5785	31.117	14.93	30	Pass
165	5825	18.664	12.71	30	Pass

Notes:

1. For U-NII-1, the antenna gain is 3.79 dBi < 6 dBi, so the output power limit shall not be reduced.
 2. For U-NII-2A, the antenna gain is 3.79 dBi < 6 dBi, so the output power limit shall not be reduced.
 3. For U-NII-2C, the antenna gain is 3.79 dBi < 6 dBi, so the output power limit shall not be reduced.
 4. For U-NII-3, the antenna gain is 3.79 dBi < 6 dBi, so the output power limit shall not be reduced.
- * Test was performed in accordance with measurement follow FCC KDB 789033 UNII test procedure Method SA-2A and use spectrum analyzer test, the duty factor was included in the total power.

802.11ac (VHT40)

Chan.	Chan. Freq. (MHz)	Average Power (mW)	Average Power (dBm)	Power Limit (dBm)	Test Result
38	5190	10.94	10.39	24	Pass
46	5230	31.696	15.01	24	Pass
54	5270	27.861	14.45	24	Pass
62	5310	9.954	9.98	24	Pass
102	5510	9.162	9.62	24	Pass
110	5550	27.861	14.45	24	Pass
134	5670	27.733	14.43	24	Pass
*142 (U-NII-2C)	5710	24.565	13.90	24	Pass
*142 (U-NII-3)	5710	1.359	1.33	30	Pass
151	5755	18.365	12.64	30	Pass
159	5795	18.281	12.62	30	Pass

Notes:

1. For U-NII-1, the antenna gain is 3.79 dBi < 6 dBi, so the output power limit shall not be reduced.
 2. For U-NII-2A, the antenna gain is 3.79 dBi < 6 dBi, so the output power limit shall not be reduced.
 3. For U-NII-2C, the antenna gain is 3.79 dBi < 6 dBi, so the output power limit shall not be reduced.
 4. For U-NII-3, the antenna gain is 3.79 dBi < 6 dBi, so the output power limit shall not be reduced.
- * Test was performed in accordance with measurement follow FCC KDB 789033 UNII test procedure Method SA-2A and use spectrum analyzer test, the duty factor was included in the total power.

802.11ac (VHT80)

Chan.	Chan. Freq. (MHz)	Average Power (mW)	Average Power (dBm)	Power Limit (dBm)	Test Result
42	5210	10.093	10.04	24	Pass
58	5290	10.046	10.02	24	Pass
106	5530	9.506	9.78	24	Pass
122	5610	10.046	10.02	24	Pass
*138 (U-NII-2C)	5690	9.745	9.89	24	Pass
*138 (U-NII-3)	5690	0.2448	-6.11	30	Pass
155	5775	10.069	10.03	30	Pass

Notes:

1. For U-NII-1, the antenna gain is 3.79 dBi < 6 dBi, so the output power limit shall not be reduced.
 2. For U-NII-2A, the antenna gain is 3.79 dBi < 6 dBi, so the output power limit shall not be reduced.
 3. For U-NII-2C, the antenna gain is 3.79 dBi < 6 dBi, so the output power limit shall not be reduced.
 4. For U-NII-3, the antenna gain is 3.79 dBi < 6 dBi, so the output power limit shall not be reduced.
- * Test was performed in accordance with measurement follow FCC KDB 789033 UNII test procedure Method SA-2A and use spectrum analyzer test, the duty factor was included in the total power.

Straddle channel power plots:

802.11a

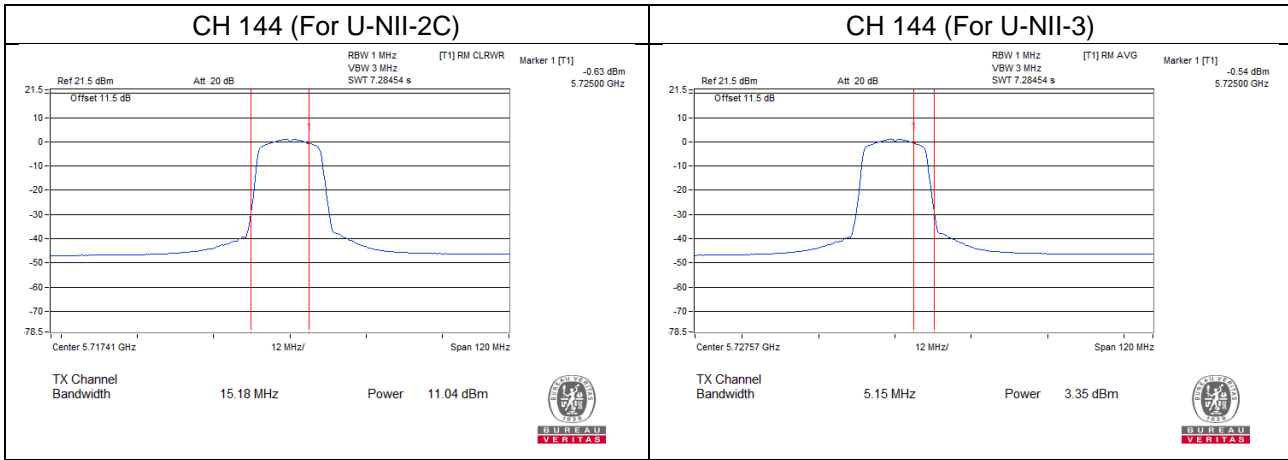

802.11n (HT20)

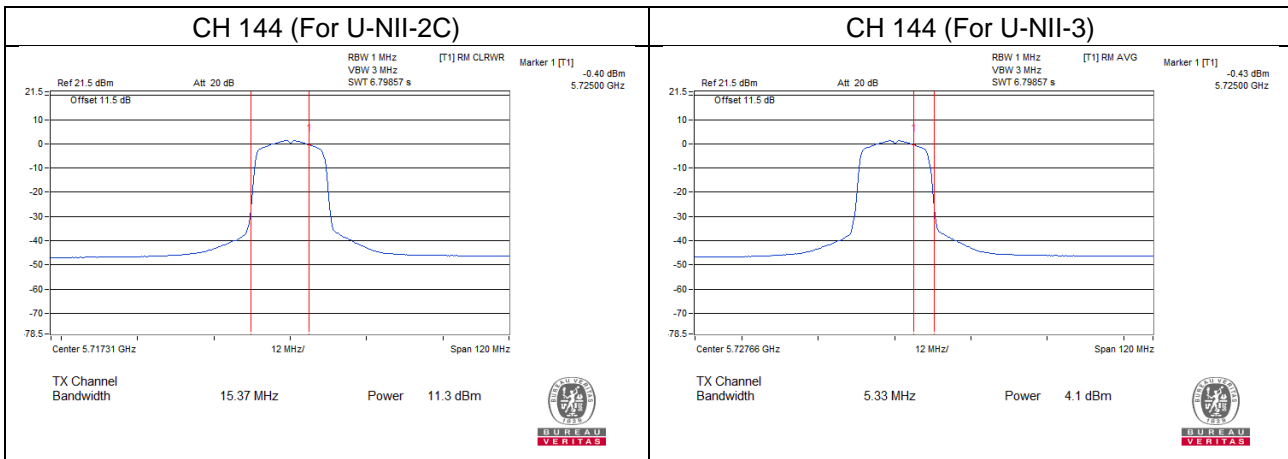

802.11n (HT40)

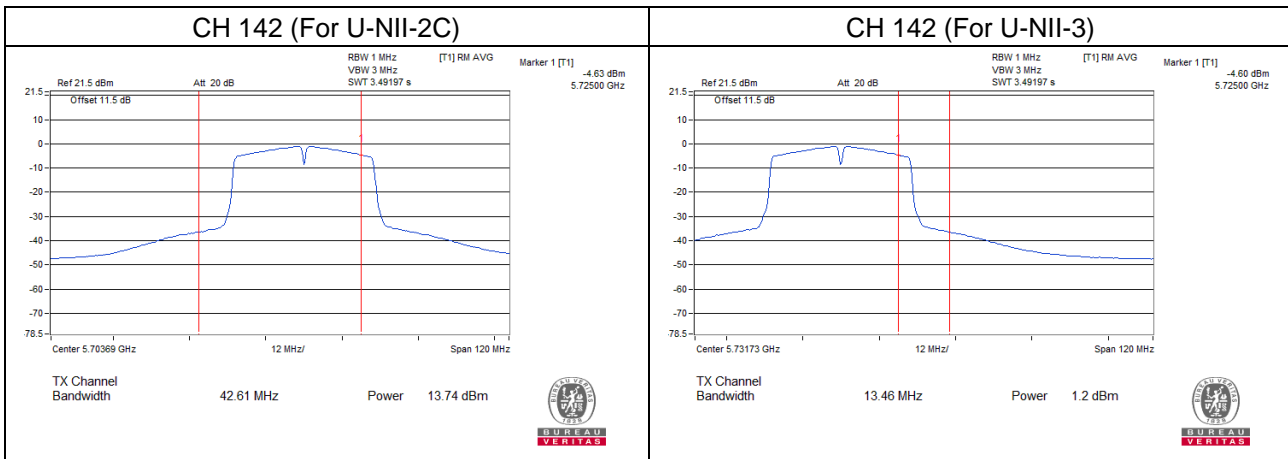

802.11ac (VHT80)

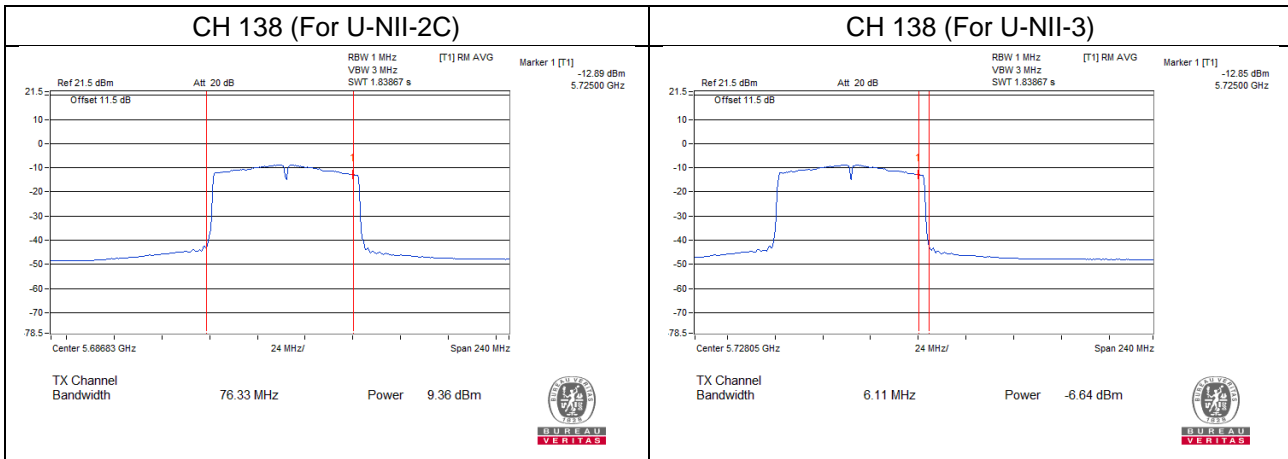

7.3 Power Spectral Density

Input Power:	3.8 Vdc	Environmental Conditions:	25°C, 60% RH	Tested By:	Chun Wu
--------------	---------	---------------------------	--------------	------------	---------

802.11a

Chan.	Chan. Freq. (MHz)	PSD w/o Duty Factor (dBm/MHz)	Duty Factor (dB)	PSD (dBm/MHz)	Max. PSD Limit (dBm/MHz)	Test Result
36	5180	1.05	0.20	1.25	11.00	Pass
40	5200	2.15	0.20	2.35	11.00	Pass
48	5240	2.01	0.20	2.21	11.00	Pass
52	5260	2.31	0.20	2.51	11.00	Pass
60	5300	2.35	0.20	2.55	11.00	Pass
64	5320	1.04	0.20	1.24	11.00	Pass
100	5500	0.20	0.20	0.40	11.00	Pass
116	5580	2.40	0.20	2.60	11.00	Pass
140	5700	-0.09	0.20	0.11	11.00	Pass
144 (U-NII-2C)	5720	-0.16	0.20	0.04	11.00	Pass

Notes:

1. For U-NII-1, the antenna gain is 3.79 dBi < 6dBi, so the power density limit shall not be reduced.
2. For U-NII-2A, the antenna gain is 3.79 dBi < 6 dBi, so the power density limit shall not be reduced.
3. For U-NII-2C, the antenna gain is 3.79 dBi < 6 dBi, so the power density limit shall not be reduced.

802.11n (HT20)

Chan.	Chan. Freq. (MHz)	PSD w/o Duty Factor (dBm/MHz)	Duty Factor (dB)	PSD (dBm/MHz)	Max. PSD Limit (dBm/MHz)	Test Result
36	5180	0.90	0.15	1.05	11.00	Pass
40	5200	1.87	0.15	2.02	11.00	Pass
48	5240	2.41	0.15	2.56	11.00	Pass
52	5260	1.64	0.15	1.79	11.00	Pass
60	5300	1.71	0.15	1.86	11.00	Pass
64	5320	0.57	0.15	0.72	11.00	Pass
100	5500	-1.10	0.15	-0.95	11.00	Pass
116	5580	1.58	0.15	1.73	11.00	Pass
140	5700	-0.44	0.15	-0.29	11.00	Pass
144 (U-NII-2C)	5720	-0.15	0.15	0.00	11.00	Pass

Notes:

1. For U-NII-1, the antenna gain is 3.79 dBi < 6dBi, so the power density limit shall not be reduced.
2. For U-NII-2A, the antenna gain is 3.79 dBi < 6 dBi, so the power density limit shall not be reduced.
3. For U-NII-2C, the antenna gain is 3.79 dBi < 6 dBi, so the power density limit shall not be reduced.

802.11n (HT40)

Chan.	Chan. Freq. (MHz)	PSD w/o Duty Factor (dBm/MHz)	Duty Factor (dB)	PSD (dBm/MHz)	Max. PSD Limit (dBm/MHz)	Test Result
38	5190	-5.20	0.30	-4.90	11.00	Pass
46	5230	-0.99	0.30	-0.69	11.00	Pass
54	5270	-1.52	0.30	-1.22	11.00	Pass
62	5310	-6.17	0.30	-5.87	11.00	Pass
102	5510	-6.14	0.30	-5.84	11.00	Pass
110	5550	-1.27	0.30	-0.97	11.00	Pass
134	5670	-1.05	0.30	-0.75	11.00	Pass
142 (U-NII-2C)	5710	-1.14	0.30	-0.84	11.00	Pass

Notes:

1. For U-NII-1, the antenna gain is 3.79 dBi < 6dBi, so the power density limit shall not be reduced.
2. For U-NII-2A, the antenna gain is 3.79 dBi < 6 dBi, so the power density limit shall not be reduced.
3. For U-NII-2C, the antenna gain is 3.79 dBi < 6 dBi, so the power density limit shall not be reduced.

802.11ac (VHT80)

Chan.	Chan. Freq. (MHz)	PSD w/o Duty Factor (dBm/MHz)	Duty Factor (dB)	PSD (dBm/MHz)	Max. PSD Limit (dBm/MHz)	Test Result
42	5210	-9.08	0.53	-8.55	11.00	Pass
58	5290	-8.99	0.53	-8.46	11.00	Pass
106	5530	-9.17	0.53	-8.64	11.00	Pass
122	5610	-9.07	0.53	-8.54	11.00	Pass
138 (U-NII-2C)	5690	-8.74	0.53	-8.21	11.00	Pass

Notes:

1. For U-NII-1, the antenna gain is 3.79 dBi < 6dBi, so the power density limit shall not be reduced.
2. For U-NII-2A, the antenna gain is 3.79 dBi < 6 dBi, so the power density limit shall not be reduced.
3. For U-NII-2C, the antenna gain is 3.79 dBi < 6 dBi, so the power density limit shall not be reduced.

802.11a

Chan.	Chan. Freq. (MHz)	PSD w/o Duty Factor (dBm/300kHz)	Duty Factor (dB)	PSD (dBm/500kHz)	PSD Limit (dBm/500kHz)	Test Result
144 (U-NII-3)	5720	-10.48	0.2	-8.06	30	Pass
149	5745	-9.67	0.2	-7.25	30	Pass
157	5785	-6.92	0.2	-4.50	30	Pass
165	5825	-9.51	0.2	-7.09	30	Pass

Note: For U-NII-3, the antenna gain is 3.79 dBi < 6 dBi, so the power density limit shall not be reduced.

802.11n (HT20)

Chan.	Chan. Freq. (MHz)	PSD w/o Duty Factor (dBm/300kHz)	Duty Factor (dB)	PSD (dBm/500kHz)	PSD Limit (dBm/500kHz)	Test Result
144 (U-NII-3)	5720	-10.46	0.15	-8.09	30	Pass
149	5745	-9.46	0.15	-7.09	30	Pass
157	5785	-7.27	0.15	-4.90	30	Pass
165	5825	-9.75	0.15	-7.38	30	Pass

Note: For U-NII-3, the antenna gain is 3.79 dBi < 6 dBi, so the power density limit shall not be reduced.

802.11n (HT40)

Chan.	Chan. Freq. (MHz)	PSD w/o Duty Factor (dBm/300kHz)	Duty Factor (dB)	PSD (dBm/500kHz)	PSD Limit (dBm/500kHz)	Test Result
142 (U-NII-3)	5710	-13.9	0.3	-11.38	30	Pass
151	5755	-13.02	0.3	-10.50	30	Pass
159	5795	-13.1	0.3	-10.58	30	Pass

Note: For U-NII-3, the antenna gain is 3.79 dBi < 6 dBi, so the power density limit shall not be reduced.

802.11ac (VHT80)

Chan.	Chan. Freq. (MHz)	PSD w/o Duty Factor (dBm/300kHz)	Duty Factor (dB)	PSD (dBm/500kHz)	PSD Limit (dBm/500kHz)	Test Result
138 (U-NII-3)	5690	-21.96	0.53	-19.21	30	Pass
155	5775	-19.34	0.53	-16.59	30	Pass

Note: For U-NII-3, the antenna gain is 3.79 dBi < 6 dBi, so the power density limit shall not be reduced.

Spectrum Plot of Maximum Value

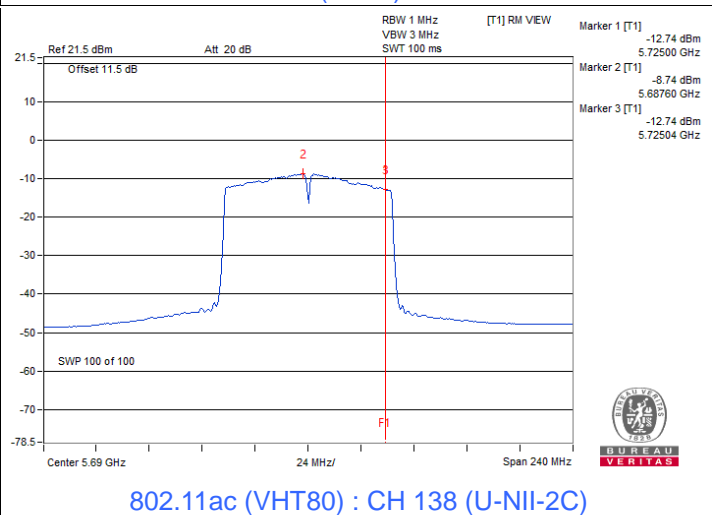
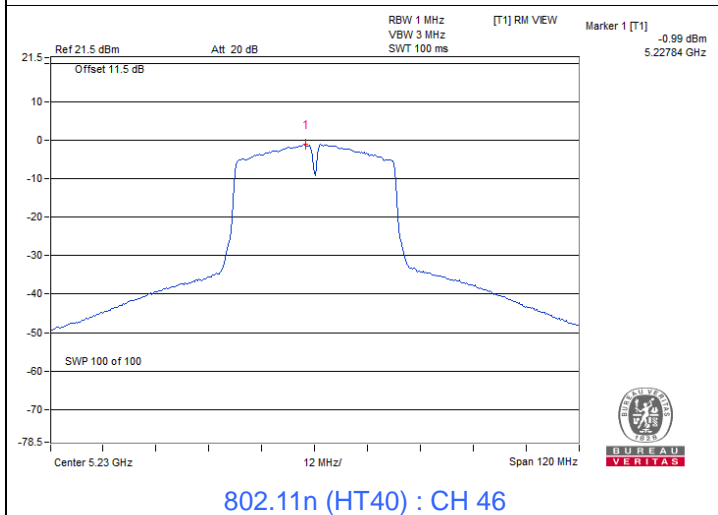
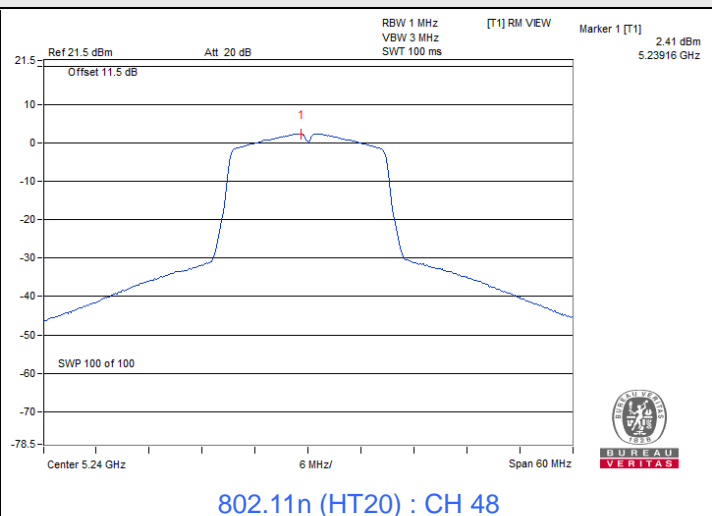
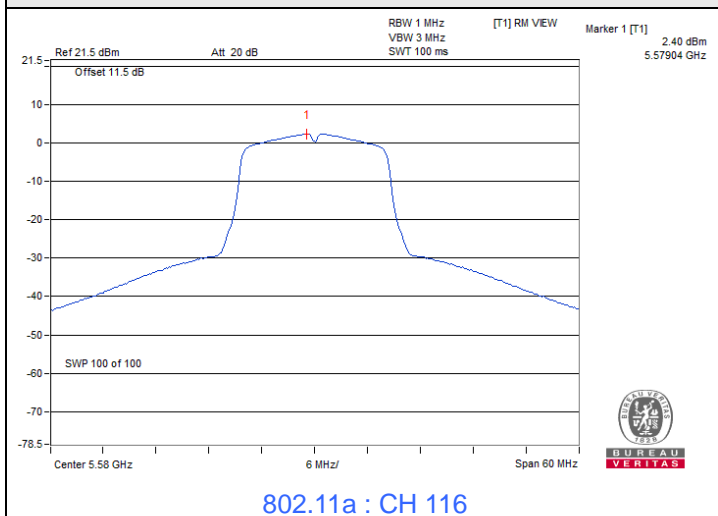



Spectrum Plot of Maximum Value

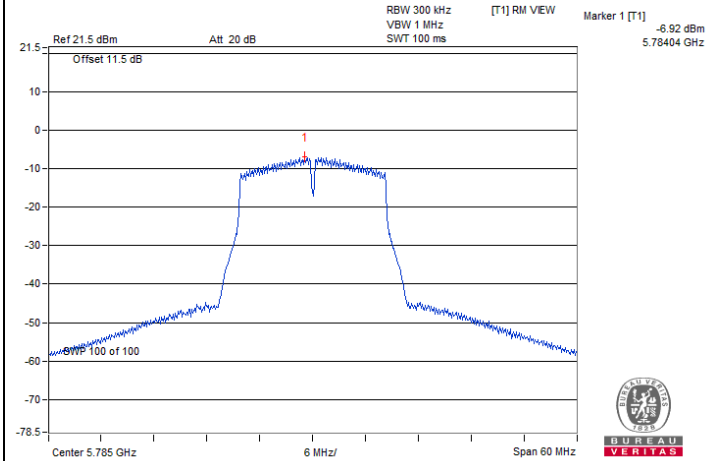

802.11a : CH 157

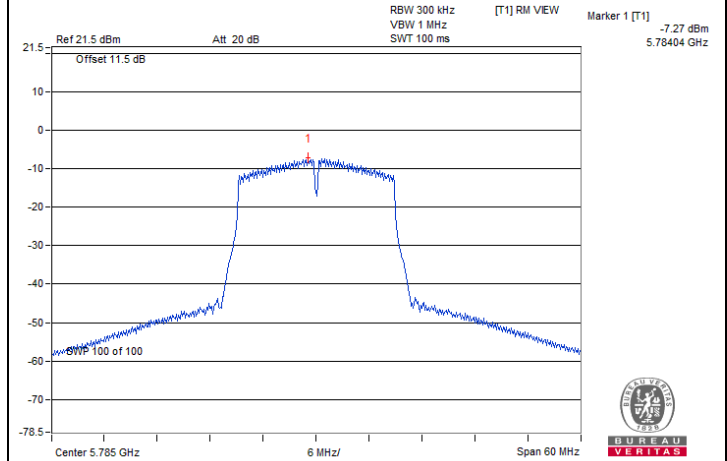

802.11n (HT20) : CH 157

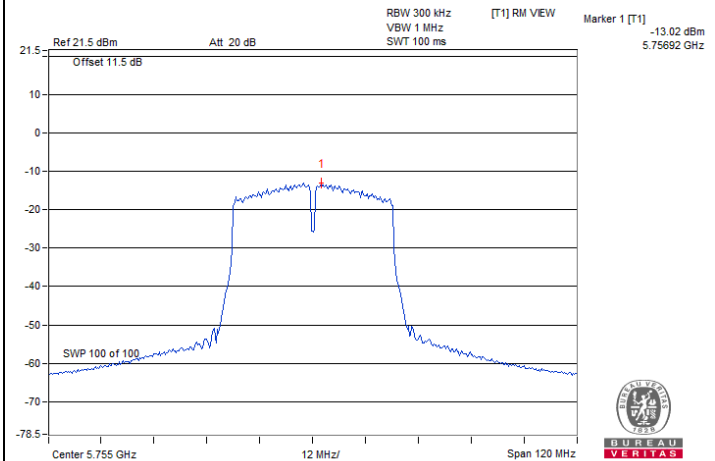

802.11n (HT40) : CH 151

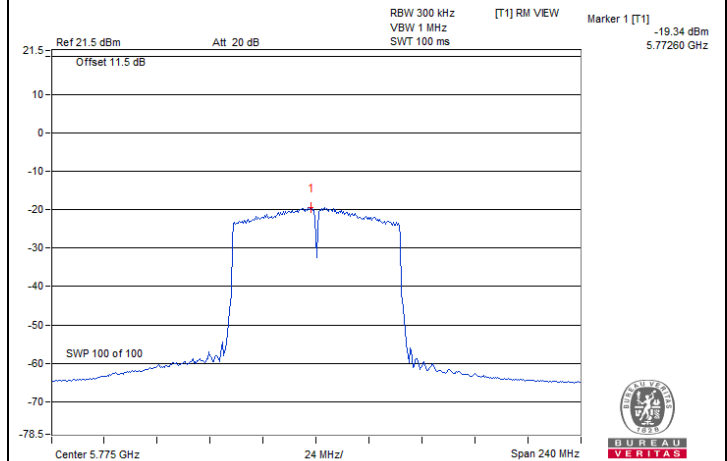

802.11ac (VHT80) : CH 155

7.4 6 dB Bandwidth

Input Power:	3.8 Vdc	Environmental Conditions:	25°C, 60% RH	Tested By:	Chun Wu
--------------	---------	---------------------------	--------------	------------	---------

802.11a

Channel	Frequency (MHz)	6dB Bandwidth (MHz)	Minimum Limit (MHz)	Test Result
144 (U-NII-3)	5720	2.57	0.5	Pass
149	5745	15.16	0.5	Pass
157	5785	15.13	0.5	Pass
165	5825	15.11	0.5	Pass

802.11n (HT20)

Channel	Frequency (MHz)	6dB Bandwidth (MHz)	Minimum Limit (MHz)	Test Result
144 (U-NII-3)	5720	2.57	0.5	Pass
149	5745	15.16	0.5	Pass
157	5785	15.16	0.5	Pass
165	5825	15.12	0.5	Pass

802.11n (HT40)

Channel	Frequency (MHz)	6dB Bandwidth (MHz)	Minimum Limit (MHz)	Test Result
142 (U-NII-3)	5710	2.63	0.5	Pass
151	5755	35.26	0.5	Pass
159	5795	35.2	0.5	Pass

802.11ac (VHT80)

Channel	Frequency (MHz)	6dB Bandwidth (MHz)	Minimum Limit (MHz)	Test Result
138 (U-NII-3)	5690	2.68	0.5	Pass
155	5775	75.49	0.5	Pass

Spectrum Plot of Minimum Value

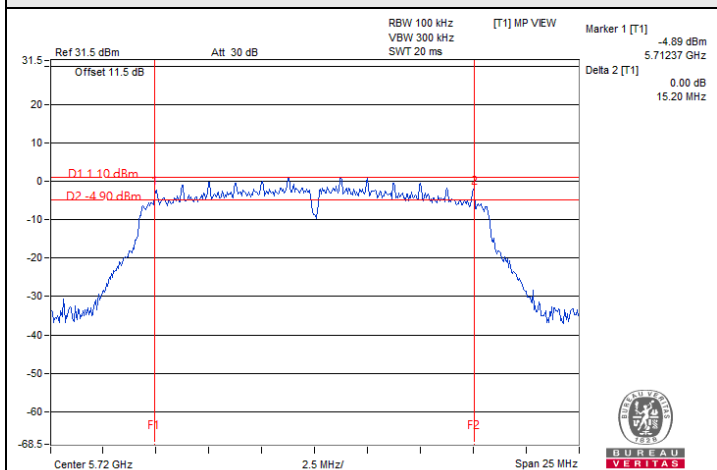

802.11a : CH 144 (U-NII-3)

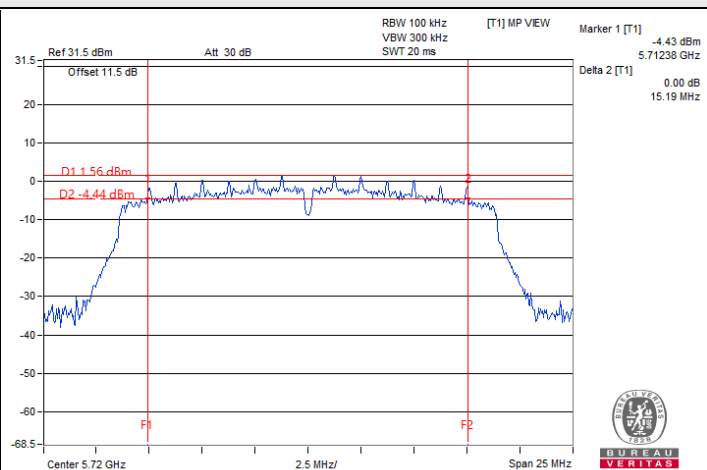

802.11n (HT20) : CH 144 (U-NII-3)

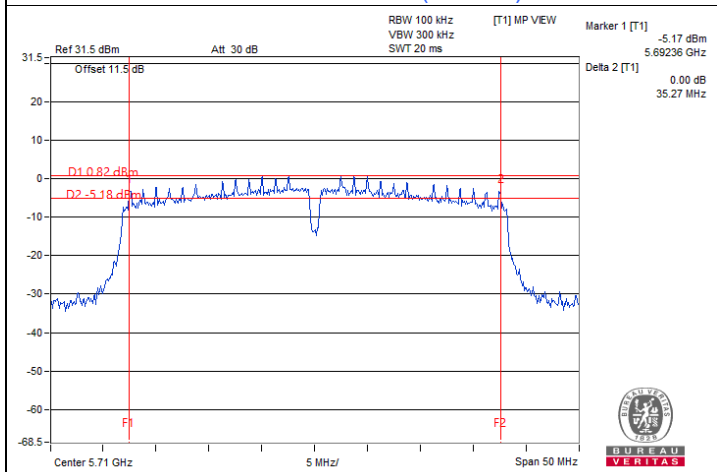

802.11n (HT40) : CH 142 (U-NII-3)

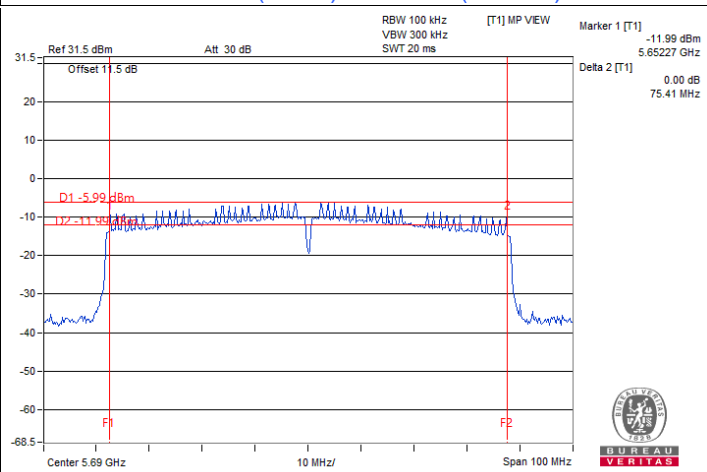

802.11ac (VHT80) : CH 138 (U-NII-3)

Notes: For U-NII-3 straddle channel = Marker 1 + Delta 2 - 5725 MHz

7.5 Occupied Bandwidth

Input Power:	3.8 Vdc	Environmental Conditions:	25°C, 60% RH	Tested By:	Chun Wu
--------------	---------	---------------------------	--------------	------------	---------

802.11a

Channel	Frequency (MHz)	Occupied Bandwidth (MHz)
36	5180	16.68
40	5200	16.68
48	5240	16.80
52	5260	16.56
60	5300	16.80
64	5320	16.68
100	5500	16.68
116	5580	16.80
140	5700	16.68
144 (U-NII-2C)	5720	13.4
144 (U-NII-3)	5720	3.4
149	5745	16.54
157	5785	16.83
165	5825	16.44

802.11n (HT20)

Channel	Frequency (MHz)	Occupied Bandwidth (MHz)
36	5180	17.88
40	5200	17.88
48	5240	17.88
52	5260	17.76
60	5300	17.88
64	5320	17.64
100	5500	17.64
116	5580	17.64
140	5700	17.88
144 (U-NII-2C)	5720	13.88
144 (U-NII-3)	5720	3.76
149	5745	17.79
157	5785	17.79
165	5825	17.69

802.11n (HT40)

Channel	Frequency (MHz)	Occupied Bandwidth (MHz)
38	5190	36.60
46	5230	36.24
54	5270	36.24
62	5310	36.24
102	5510	36.24
110	5550	36.48
134	5670	36.24
142 (U-NII-2C)	5710	33.24
142 (U-NII-3)	5710	3.24
151	5755	36.24
159	5795	36.25

802.11ac (VHT80)

Channel	Frequency (MHz)	Occupied Bandwidth (MHz)
42	5210	75.84
58	5290	75.36
106	5530	74.88
122	5610	75.36
138 (U-NII-2C)	5690	72.92
138 (U-NII-3)	5690	2.92
155	5775	75.00



Spectrum Plot of Maximum Value

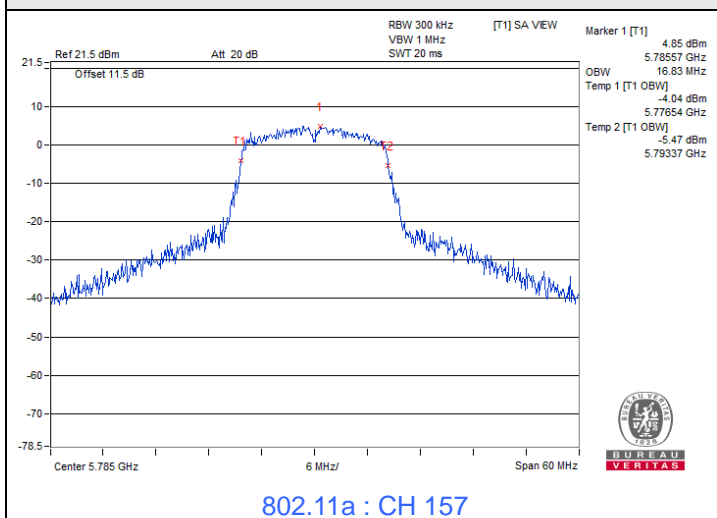

802.11a : CH 157

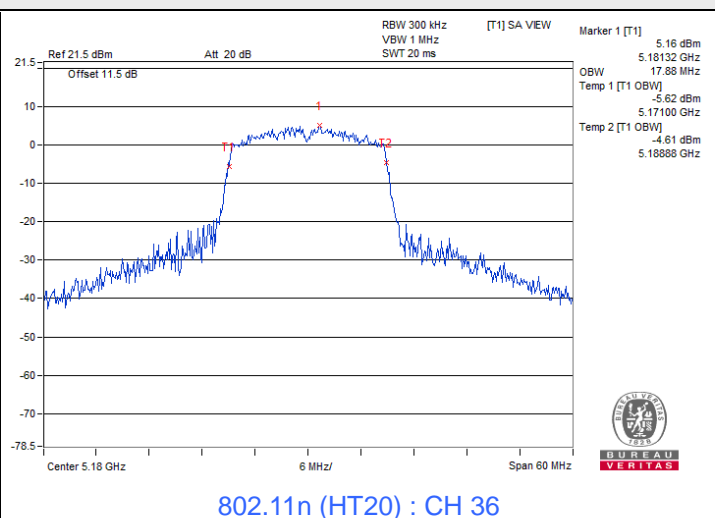

802.11n (HT20) : CH 36

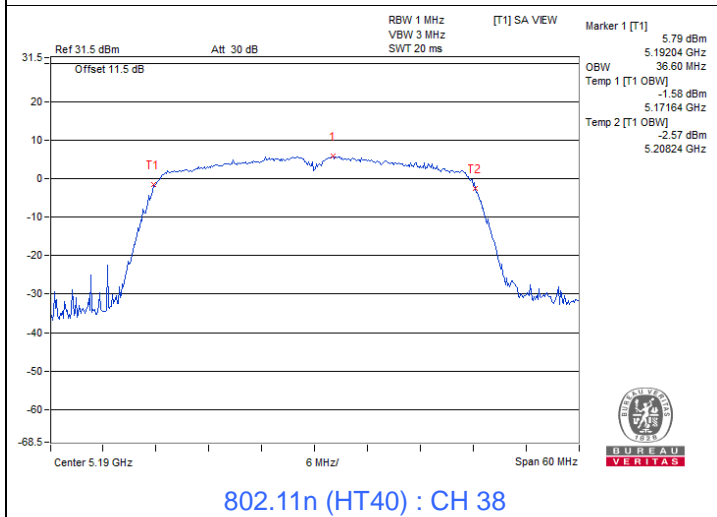

802.11n (HT40) : CH 38

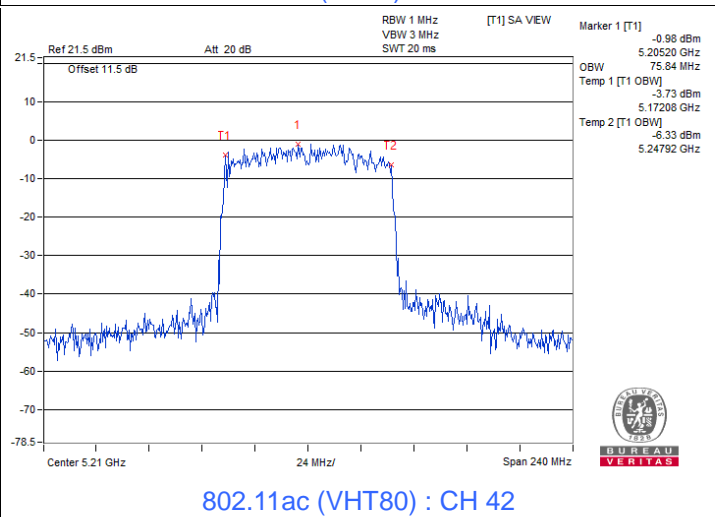

802.11ac (VHT80) : CH 42



Spectrum Plot for nearby DFS band (DFS is required, if 99% OCP straddle into U-NII-2A band)

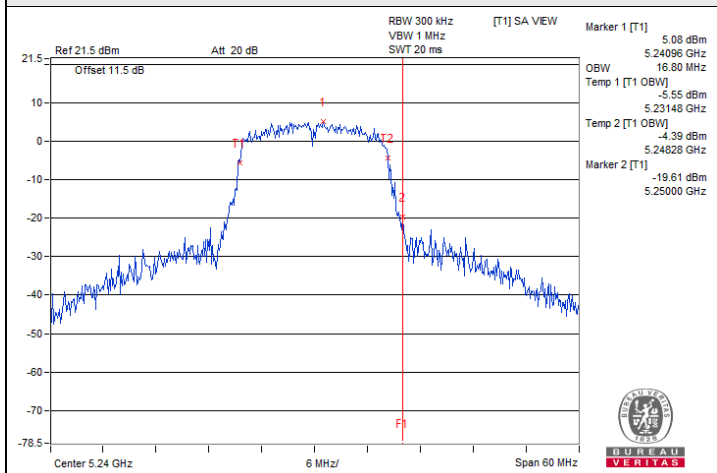

802.11a : CH 48

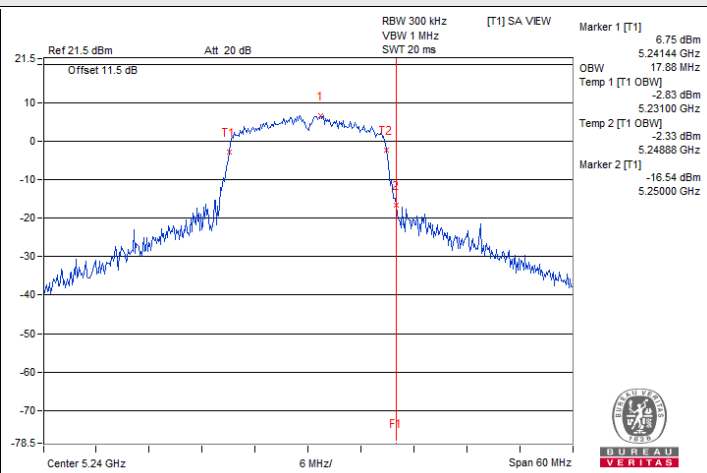

802.11n (HT20) : CH 48

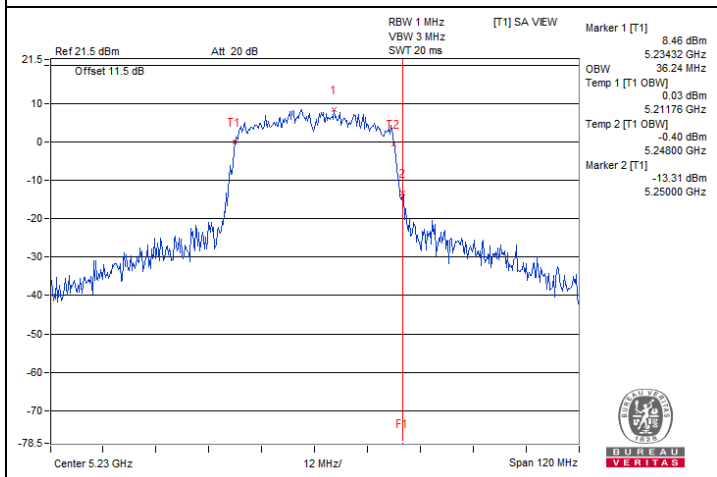

802.11n (HT40) : CH 46

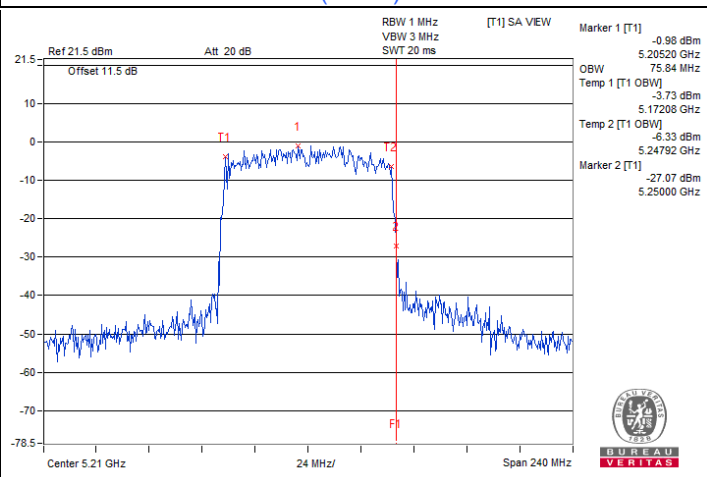

802.11ac (VHT80) : CH 42



Spectrum Plot for nearby DFS band (DFS is required, if 99% OCP straddle into U-NII-2C band)

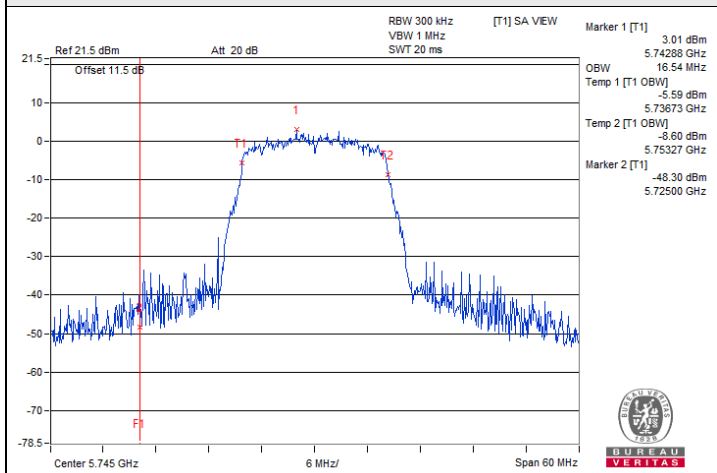

802.11a : CH 149

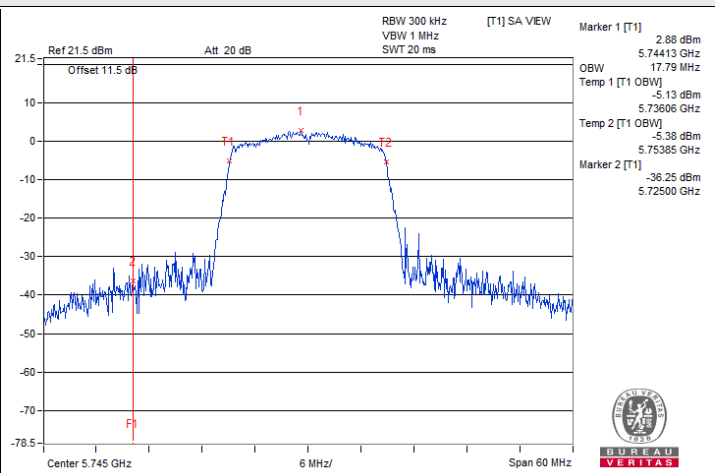

802.11n (HT20) : CH 149

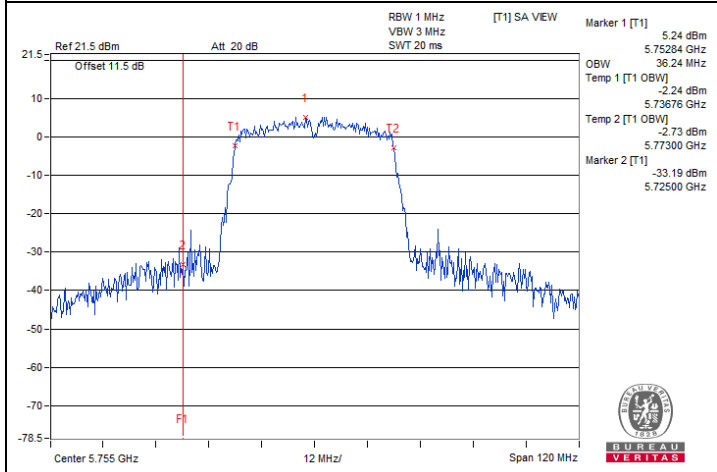

802.11n (HT40) : CH 151

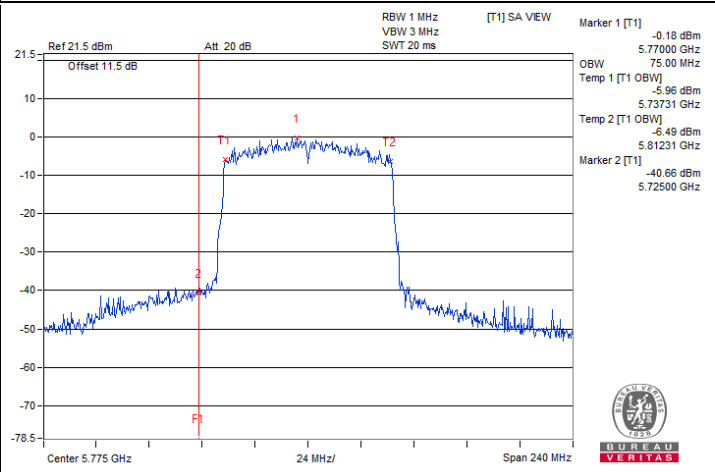

802.11ac (VHT80) : CH 155

7.6 Frequency Stability

Input Power:	3.8 Vdc	Environmental Conditions:	25°C, 60% RH	Tested By:	Chun Wu
--------------	---------	---------------------------	--------------	------------	---------

802.11a

Frequency Stability Versus Temp.									
Operating Frequency: 5180 MHz									
TEMP. (°C)	Power Supply (Vdc)	0 Minute		2 Minutes		5 Minutes		10 Minutes	
		Measured Frequency (MHz)	Test Result	Measured Frequency (MHz)	Test Result	Measured Frequency (MHz)	Test Result	Measured Frequency (MHz)	Test Result
60	3.8	5180.0189	Pass	5180.0192	Pass	5180.0179	Pass	5180.0165	Pass
50	3.8	5180.0168	Pass	5180.0178	Pass	5180.0153	Pass	5180.0157	Pass
40	3.8	5179.983	Pass	5179.9838	Pass	5179.9857	Pass	5179.9836	Pass
30	3.8	5180.0264	Pass	5180.0242	Pass	5180.0243	Pass	5180.0248	Pass
20	3.8	5179.988	Pass	5179.9863	Pass	5179.9887	Pass	5179.9883	Pass
10	3.8	5179.979	Pass	5179.9791	Pass	5179.9815	Pass	5179.9816	Pass
0	3.8	5180.0182	Pass	5180.0141	Pass	5180.0175	Pass	5180.0145	Pass
-10	3.8	5179.9811	Pass	5179.98	Pass	5179.9803	Pass	5179.98	Pass
-20	3.8	5180.0192	Pass	5180.0202	Pass	5180.0195	Pass	5180.0185	Pass

Frequency Stability Versus Voltage									
Operating Frequency: 5180 MHz									
TEMP. (°C)	Power Supply (Vdc)	0 Minute		2 Minutes		5 Minutes		10 Minutes	
		Measured Frequency (MHz)	Test Result	Measured Frequency (MHz)	Test Result	Measured Frequency (MHz)	Test Result	Measured Frequency (MHz)	Test Result
20	4.37	5179.9972	Pass	5179.9981	Pass	5179.9974	Pass	5179.9983	Pass
	3.8	5179.988	Pass	5179.9863	Pass	5179.9887	Pass	5179.9883	Pass
	3.23	5179.9822	Pass	5179.9846	Pass	5179.9824	Pass	5179.9851	Pass

7.7 AC Power Conducted Emissions

RF Mode	TX 802.11a	Channel	CH 116 : 5580 MHz
Frequency Range	150 kHz ~ 30 MHz	Detector Function & Resolution Bandwidth	Quasi-Peak (QP) / Average (AV), 9 kHz
Input Power	120 Vac, 60 Hz	Environmental Conditions	23°C, 68% RH
Tested By	Thomas Cheng		

Phase Of Power : Line (L)										
No	Frequency (MHz)	Correction Factor (dB)	Reading Value (dBuV)		Emission Level (dBuV)		Limit (dBuV)		Margin (dB)	
			Q.P.	AV.	Q.P.	AV.	Q.P.	AV.	Q.P.	AV.
1	0.33400	10.21	31.51	26.13	41.72	36.34	59.35	49.35	-17.63	-13.01
2	0.39800	10.24	27.97	25.31	38.21	35.55	57.90	47.90	-19.69	-12.35
3	0.95400	10.30	25.28	16.49	35.58	26.79	56.00	46.00	-20.42	-19.21
4	1.93800	10.37	22.90	10.20	33.27	20.57	56.00	46.00	-22.73	-25.43
5	5.26200	10.41	33.79	21.69	44.20	32.10	60.00	50.00	-15.80	-17.90
6	18.22600	10.58	19.71	12.95	30.29	23.53	60.00	50.00	-29.71	-26.47

Remarks:

1. Q.P. and AV. are abbreviations of quasi-peak and average individually.
2. The emission levels of other frequencies were very low against the limit.
3. Margin value = Emission level – Limit value
4. Correction factor = Insertion loss + Cable loss
5. Emission Level = Correction Factor + Reading Value

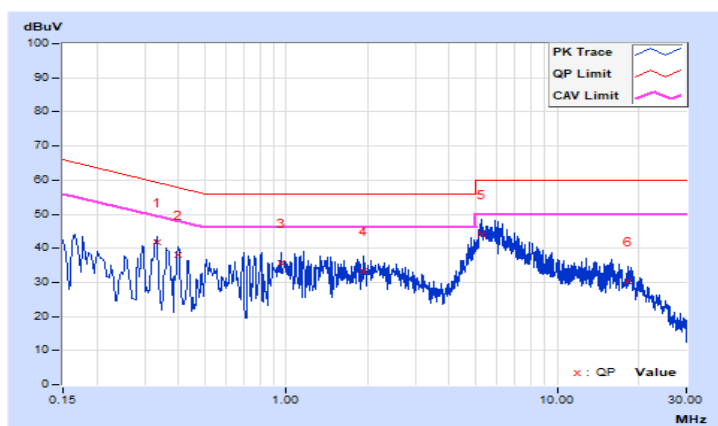

RF Mode	TX 802.11a	Channel	CH 116 : 5580 MHz
Frequency Range	150 kHz ~ 30 MHz	Detector Function & Resolution Bandwidth	Quasi-Peak (QP) / Average (AV), 9 kHz
Input Power	120 Vac, 60 Hz	Environmental Conditions	23°C, 68% RH
Tested By	Thomas Cheng		

Phase Of Power : Neutral (N)										
No	Frequency (MHz)	Correction Factor (dB)	Reading Value (dBuV)		Emission Level (dBuV)		Limit (dBuV)		Margin (dB)	
			Q.P.	AV.	Q.P.	AV.	Q.P.	AV.	Q.P.	AV.
1	0.34577	10.24	37.68	32.95	47.92	43.19	59.06	49.06	-11.14	-5.87
2	0.37718	10.25	32.28	27.37	42.53	37.62	58.34	48.34	-15.81	-10.72
3	0.56442	10.27	23.63	15.95	33.90	26.22	56.00	46.00	-22.10	-19.78
4	1.04200	10.31	27.35	20.74	37.66	31.05	56.00	46.00	-18.34	-14.95
5	5.61800	10.43	36.84	26.56	47.27	36.99	60.00	50.00	-12.73	-13.01
6	18.93400	10.72	24.15	10.59	34.87	21.31	60.00	50.00	-25.13	-28.69

Remarks:

1. Q.P. and AV. are abbreviations of quasi-peak and average individually.
2. The emission levels of other frequencies were very low against the limit.
3. Margin value = Emission level – Limit value
4. Correction factor = Insertion loss + Cable loss
5. Emission Level = Correction Factor + Reading Value

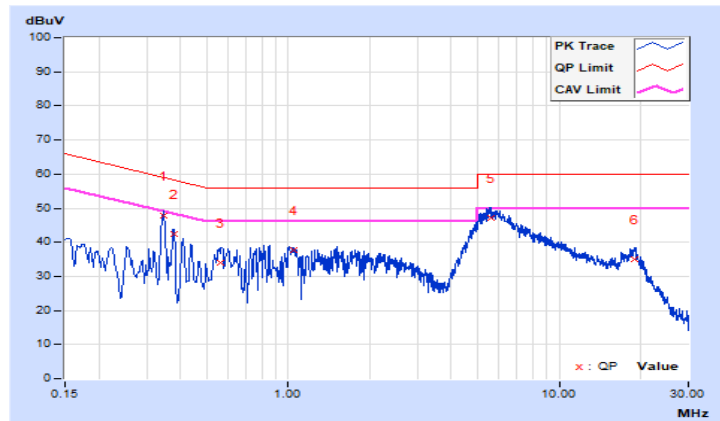

7.8 Unwanted Emissions below 1 GHz

RF Mode	TX 802.11a	Channel	CH 116 : 5580 MHz
Frequency Range	9 kHz ~ 1 GHz	Detector Function & Bandwidth	(QP) RB = 120kHz
Input Power	120 Vac, 60 Hz	Environmental Conditions	25°C, 60% RH
Tested By	Karl Lee		

Antenna Polarity & Test Distance : Horizontal at 3 m								
No	Frequency (MHz)	Emission Level (dBuV/m)	Limit (dBuV/m)	Margin (dB)	Antenna Height (m)	Table Angle (Degree)	Raw Value (dBuV)	Correction Factor (dB/m)
1	85.56	29.89 QP	40.00	-10.11	1.06 H	42	52.78	-22.89
2	195.11	22.90 QP	43.50	-20.60	1.57 H	301	42.60	-19.70
3	226.47	26.19 QP	46.00	-19.81	1.25 H	148	45.73	-19.54
4	369.80	39.35 QP	46.00	-6.65	2.22 H	116	53.31	-13.96
5	431.72	32.83 QP	46.00	-13.17	1.76 H	199	45.07	-12.24
6	824.34	21.09 QP	46.00	-24.91	2.53 H	37	26.45	-5.36

Remarks:

1. Emission Level(dBuV/m) = Raw Value(dBuV) + Correction Factor(dB/m)
2. Correction Factor(dB/m) = Antenna Factor(dB/m) + Cable Factor(dB) – Pre-Amplifier Factor(dB)
3. Margin value = Emission Level – Limit value
4. The other emission levels were very low against the limit of frequency range 30 MHz ~ 1 GHz.
5. The emission levels were very low against the limit of frequency range 9 kHz ~ 30 MHz: the amplitude of spurious emissions attenuated more than 20 dB below the permissible value to be report.

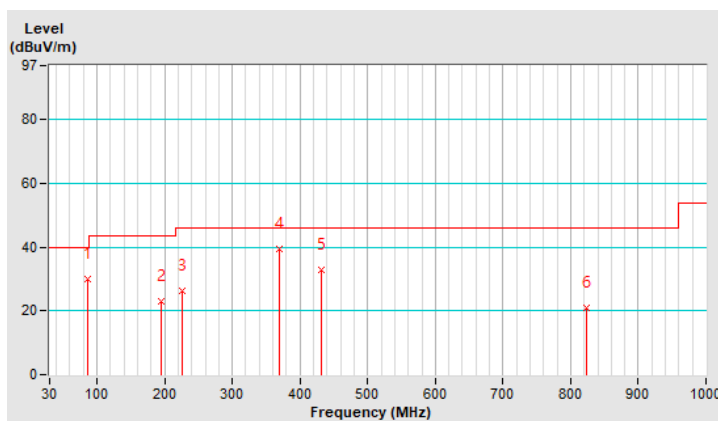

RF Mode	TX 802.11a	Channel	CH 116 : 5580 MHz
Frequency Range	9 kHz ~ 1 GHz	Detector Function & Bandwidth	(QP) RB = 120kHz
Input Power	120 Vac, 60 Hz	Environmental Conditions	25°C, 60% RH
Tested By	Karl Lee		

Antenna Polarity & Test Distance : Vertical at 3 m								
No	Frequency (MHz)	Emission Level (dBuV/m)	Limit (dBuV/m)	Margin (dB)	Antenna Height (m)	Table Angle (Degree)	Raw Value (dBuV)	Correction Factor (dB/m)
1	55.04	35.18 QP	40.00	-4.82	1.28 V	107	52.58	-17.40
2	89.66	29.92 QP	43.50	-13.58	1.75 V	61	52.84	-22.92
3	191.56	22.50 QP	43.50	-21.00	1.81 V	332	41.97	-19.47
4	386.09	37.43 QP	46.00	-8.57	1.16 V	274	51.13	-13.70
5	520.22	26.28 QP	46.00	-19.72	1.37 V	88	37.00	-10.72
6	714.97	24.34 QP	46.00	-21.66	1.53 V	289	31.52	-7.18

Remarks:

1. Emission Level(dBuV/m) = Raw Value(dBuV) + Correction Factor(dB/m)
2. Correction Factor(dB/m) = Antenna Factor(dB/m) + Cable Factor(dB) – Pre-Amplifier Factor(dB)
3. Margin value = Emission Level – Limit value
4. The other emission levels were very low against the limit of frequency range 30 MHz ~ 1 GHz.
5. The emission levels were very low against the limit of frequency range 9 kHz ~ 30 MHz: the amplitude of spurious emissions attenuated more than 20 dB below the permissible value to be report.

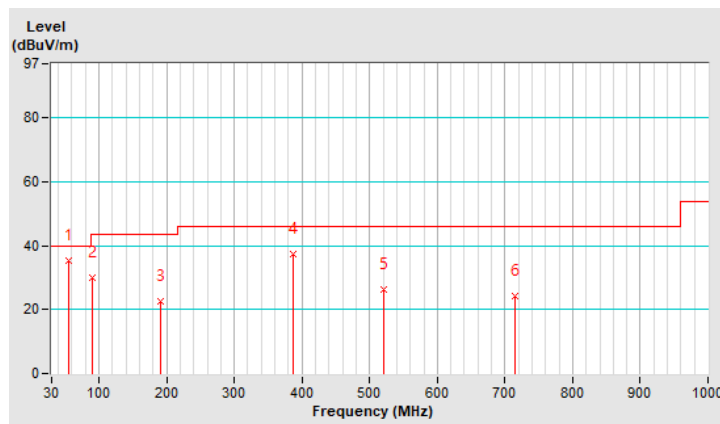

7.9 Unwanted Emissions above 1 GHz

RF Mode	TX 802.11a	Channel	CH 36 : 5180 MHz
Frequency Range	1 GHz ~ 40 GHz	Detector Function & Bandwidth	(PK) RB = 1 MHz, VB = 3 MHz (AV) RB = 1 MHz, VB = 1 kHz
Input Power	120 Vac, 60 Hz	Environmental Conditions	25°C, 60% RH
Tested By	Charles Hsiao		

Antenna Polarity & Test Distance : Horizontal at 3 m								
No	Frequency (MHz)	Emission Level (dBuV/m)	Limit (dBuV/m)	Margin (dB)	Antenna Height (m)	Table Angle (Degree)	Raw Value (dBuV)	Correction Factor (dB/m)
1	5150.00	59.23 PK	74.00	-14.77	1.00 H	90	49.48	9.75
2	5150.00	49.11 AV	54.00	-4.89	1.00 H	90	39.36	9.75
3	*5180.00	102.39 PK			1.00 H	90	61.11	41.28
4	*5180.00	95.45 AV			1.00 H	90	54.17	41.28
5	#10360.00	58.09 PK	68.20	-10.11	1.50 H	3	43.02	15.07
Antenna Polarity & Test Distance : Vertical at 3 m								
No	Frequency (MHz)	Emission Level (dBuV/m)	Limit (dBuV/m)	Margin (dB)	Antenna Height (m)	Table Angle (Degree)	Raw Value (dBuV)	Correction Factor (dB/m)
1	5150.00	58.35 PK	74.00	-15.65	1.80 V	239	48.60	9.75
2	5150.00	48.87 AV	54.00	-5.13	1.80 V	239	39.12	9.75
3	*5180.00	98.41 PK			1.80 V	239	57.13	41.28
4	*5180.00	91.14 AV			1.80 V	239	49.86	41.28
5	#10360.00	57.75 PK	68.20	-10.45	1.50 V	24	42.68	15.07

Remarks:

1. Emission Level(dBuV/m) = Raw Value(dBuV) + Correction Factor(dB/m)
2. Correction Factor(dB/m) = Antenna Factor(dB/m) + Cable Factor(dB) – Pre-Amplifier Factor(dB)
3. Margin value = Emission Level – Limit value
4. The other emission levels were very low against the limit.
5. " * ": Fundamental frequency, the limit was restricted at the RF Output Power.
6. " # ": The radiated frequency is out of the restricted band.



RF Mode	TX 802.11a	Channel	CH 40 : 5200 MHz
Frequency Range	1 GHz ~ 40 GHz	Detector Function & Bandwidth	(PK) RB = 1 MHz, VB = 3 MHz (AV) RB = 1 MHz, VB = 1 kHz
Input Power	120 Vac, 60 Hz	Environmental Conditions	25°C, 60% RH
Tested By	Charles Hsiao		

Antenna Polarity & Test Distance : Horizontal at 3 m								
No	Frequency (MHz)	Emission Level (dBuV/m)	Limit (dBuV/m)	Margin (dB)	Antenna Height (m)	Table Angle (Degree)	Raw Value (dBuV)	Correction Factor (dB/m)
1	*5200.00	103.65 PK			1.00 H	90	62.29	41.36
2	*5200.00	96.57 AV			1.00 H	90	55.21	41.36
3	#10400.00	58.10 PK	68.20	-10.10	1.22 H	211	43.03	15.07
Antenna Polarity & Test Distance : Vertical at 3 m								
No	Frequency (MHz)	Emission Level (dBuV/m)	Limit (dBuV/m)	Margin (dB)	Antenna Height (m)	Table Angle (Degree)	Raw Value (dBuV)	Correction Factor (dB/m)
1	*5200.00	99.84 PK			1.80 V	239	58.48	41.36
2	*5200.00	92.36 AV			1.80 V	239	51.00	41.36
3	#10400.00	57.84 PK	68.20	-10.36	1.32 V	300	42.77	15.07

Remarks:

1. Emission Level(dBuV/m) = Raw Value(dBuV) + Correction Factor(dB/m)
2. Correction Factor(dB/m) = Antenna Factor(dB/m) + Cable Factor(dB) – Pre-Amplifier Factor(dB)
3. Margin value = Emission Level – Limit value
4. The other emission levels were very low against the limit.
5. " * ": Fundamental frequency, the limit was restricted at the RF Output Power.
6. " # ": The radiated frequency is out of the restricted band.

RF Mode	TX 802.11a	Channel	CH 48 : 5240 MHz
Frequency Range	1 GHz ~ 40 GHz	Detector Function & Bandwidth	(PK) RB = 1 MHz, VB = 3 MHz (AV) RB = 1 MHz, VB = 1 kHz
Input Power	120 Vac, 60 Hz	Environmental Conditions	25°C, 60% RH
Tested By	Charles Hsiao		

Antenna Polarity & Test Distance : Horizontal at 3 m								
No	Frequency (MHz)	Emission Level (dBuV/m)	Limit (dBuV/m)	Margin (dB)	Antenna Height (m)	Table Angle (Degree)	Raw Value (dBuV)	Correction Factor (dB/m)
1	*5240.00	102.13 PK			1.00 H	90	60.75	41.38
2	*5240.00	95.55 AV			1.00 H	90	54.17	41.38
3	5350.00	58.87 PK	74.00	-15.13	1.00 H	90	49.12	9.75
4	5350.00	48.66 AV	54.00	-5.34	1.00 H	90	38.91	9.75
5	#10480.00	58.06 PK	68.20	-10.14	1.50 H	21	42.88	15.18

Antenna Polarity & Test Distance : Vertical at 3 m								
No	Frequency (MHz)	Emission Level (dBuV/m)	Limit (dBuV/m)	Margin (dB)	Antenna Height (m)	Table Angle (Degree)	Raw Value (dBuV)	Correction Factor (dB/m)
1	*5240.00	97.50 PK			1.80 V	239	56.12	41.38
2	*5240.00	90.63 AV			1.80 V	239	49.25	41.38
3	5350.00	58.65 PK	74.00	-15.35	1.80 V	239	48.90	9.75
4	5350.00	48.55 AV	54.00	-5.45	1.80 V	239	38.80	9.75
5	#10360.00	57.77 PK	68.20	-10.43	1.50 V	3	42.70	15.07

Remarks:

1. Emission Level(dBuV/m) = Raw Value(dBuV) + Correction Factor(dB/m)
2. Correction Factor(dB/m) = Antenna Factor(dB/m) + Cable Factor(dB) – Pre-Amplifier Factor(dB)
3. Margin value = Emission Level – Limit value
4. The other emission levels were very low against the limit.
5. " * ": Fundamental frequency, the limit was restricted at the RF Output Power.
6. " # ": The radiated frequency is out of the restricted band.



RF Mode	TX 802.11n (HT20)	Channel	CH 36 : 5180 MHz
Frequency Range	1 GHz ~ 40 GHz	Detector Function & Bandwidth	(PK) RB = 1 MHz, VB = 3 MHz (AV) RB = 1 MHz, VB = 1 kHz
Input Power	120 Vac, 60 Hz	Environmental Conditions	25°C, 60% RH
Tested By	Charles Hsiao		

Antenna Polarity & Test Distance : Horizontal at 3 m

No	Frequency (MHz)	Emission Level (dBuV/m)	Limit (dBuV/m)	Margin (dB)	Antenna Height (m)	Table Angle (Degree)	Raw Value (dBuV)	Correction Factor (dB/m)
1	5150.00	62.00 PK	74.00	-12.00	1.00 H	90	52.25	9.75
2	5150.00	50.34 AV	54.00	-3.66	1.00 H	90	40.59	9.75
3	*5180.00	101.59 PK			1.00 H	90	60.31	41.28
4	*5180.00	94.75 AV			1.00 H	90	53.47	41.28
5	#10360.00	58.16 PK	68.20	-10.04	1.50 H	7	43.09	15.07

Antenna Polarity & Test Distance : Vertical at 3 m

No	Frequency (MHz)	Emission Level (dBuV/m)	Limit (dBuV/m)	Margin (dB)	Antenna Height (m)	Table Angle (Degree)	Raw Value (dBuV)	Correction Factor (dB/m)
1	5150.00	59.63 PK	74.00	-14.37	1.80 V	239	49.88	9.75
2	5150.00	49.44 AV	54.00	-4.56	1.80 V	239	39.69	9.75
3	*5180.00	97.55 PK			1.80 V	239	56.27	41.28
4	*5180.00	90.75 AV			1.80 V	239	49.47	41.28
5	#10360.00	57.93 PK	68.20	-10.27	1.32 V	117	42.86	15.07

Remarks:

1. Emission Level(dBuV/m) = Raw Value(dBuV) + Correction Factor(dB/m)
2. Correction Factor(dB/m) = Antenna Factor(dB/m) + Cable Factor(dB) – Pre-Amplifier Factor(dB)
3. Margin value = Emission Level – Limit value
4. The other emission levels were very low against the limit.
5. " * " : Fundamental frequency, the limit was restricted at the RF Output Power.
6. " # " : The radiated frequency is out of the restricted band.



RF Mode	TX 802.11n (HT20)	Channel	CH 40 : 5200 MHz
Frequency Range	1 GHz ~ 40 GHz	Detector Function & Bandwidth	(PK) RB = 1 MHz, VB = 3 MHz (AV) RB = 1 MHz, VB = 1 kHz
Input Power	120 Vac, 60 Hz	Environmental Conditions	25°C, 60% RH
Tested By	Charles Hsiao		

Antenna Polarity & Test Distance : Horizontal at 3 m								
No	Frequency (MHz)	Emission Level (dBuV/m)	Limit (dBuV/m)	Margin (dB)	Antenna Height (m)	Table Angle (Degree)	Raw Value (dBuV)	Correction Factor (dB/m)
1	*5200.00	102.37 PK			1.00 H	90	61.01	41.36
2	*5200.00	95.66 AV			1.00 H	90	54.30	41.36
3	#10400.00	58.16 PK	68.20	-10.04	1.66 H	6	43.09	15.07
Antenna Polarity & Test Distance : Vertical at 3 m								
No	Frequency (MHz)	Emission Level (dBuV/m)	Limit (dBuV/m)	Margin (dB)	Antenna Height (m)	Table Angle (Degree)	Raw Value (dBuV)	Correction Factor (dB/m)
1	*5200.00	98.54 PK			1.80 V	239	57.18	41.36
2	*5200.00	91.70 AV			1.80 V	239	50.34	41.36
3	#10400.00	57.98 PK	68.20	-10.22	1.55 V	19	42.91	15.07

Remarks:

1. Emission Level(dBuV/m) = Raw Value(dBuV) + Correction Factor(dB/m)
2. Correction Factor(dB/m) = Antenna Factor(dB/m) + Cable Factor(dB) – Pre-Amplifier Factor(dB)
3. Margin value = Emission Level – Limit value
4. The other emission levels were very low against the limit.
5. " * ": Fundamental frequency, the limit was restricted at the RF Output Power.
6. " # ": The radiated frequency is out of the restricted band.



RF Mode	TX 802.11n (HT20)	Channel	CH 48 : 5240 MHz
Frequency Range	1 GHz ~ 40 GHz	Detector Function & Bandwidth	(PK) RB = 1 MHz, VB = 3 MHz (AV) RB = 1 MHz, VB = 1 kHz
Input Power	120 Vac, 60 Hz	Environmental Conditions	25°C, 60% RH
Tested By	Charles Hsiao		

Antenna Polarity & Test Distance : Horizontal at 3 m

No	Frequency (MHz)	Emission Level (dBuV/m)	Limit (dBuV/m)	Margin (dB)	Antenna Height (m)	Table Angle (Degree)	Raw Value (dBuV)	Correction Factor (dB/m)
1	*5240.00	102.37 PK			1.00 H	90	60.99	41.38
2	*5240.00	95.46 AV			1.00 H	90	54.08	41.38
3	5350.00	58.89 PK	74.00	-15.11	1.00 H	90	49.14	9.75
4	5350.00	49.00 AV	54.00	-5.00	1.00 H	90	39.25	9.75
5	#10480.00	58.17 PK	68.20	-10.03	1.47 H	77	42.99	15.18

Antenna Polarity & Test Distance : Vertical at 3 m

No	Frequency (MHz)	Emission Level (dBuV/m)	Limit (dBuV/m)	Margin (dB)	Antenna Height (m)	Table Angle (Degree)	Raw Value (dBuV)	Correction Factor (dB/m)
1	*5240.00	97.01 PK			1.80 V	239	55.63	41.38
2	*5240.00	90.33 AV			1.80 V	239	48.95	41.38
3	5350.00	58.65 PK	74.00	-15.35	1.80 V	239	48.90	9.75
4	5350.00	48.70 AV	54.00	-5.30	1.80 V	239	38.95	9.75
5	#10480.00	58.05 PK	68.20	-10.15	1.15 V	14	42.87	15.18

Remarks:

1. Emission Level(dBuV/m) = Raw Value(dBuV) + Correction Factor(dB/m)
2. Correction Factor(dB/m) = Antenna Factor(dB/m) + Cable Factor(dB) – Pre-Amplifier Factor(dB)
3. Margin value = Emission Level – Limit value
4. The other emission levels were very low against the limit.
5. " * ": Fundamental frequency, the limit was restricted at the RF Output Power.
6. " # ": The radiated frequency is out of the restricted band.



RF Mode	TX 802.11n (HT40)	Channel	CH 38 : 5190 MHz
Frequency Range	1 GHz ~ 40 GHz	Detector Function & Bandwidth	(PK) RB = 1 MHz, VB = 3 MHz (AV) RB = 1 MHz, VB = 3 kHz
Input Power	120 Vac, 60 Hz	Environmental Conditions	25°C, 60% RH
Tested By	Charles Hsiao		

Antenna Polarity & Test Distance : Horizontal at 3 m

No	Frequency (MHz)	Emission Level (dBuV/m)	Limit (dBuV/m)	Margin (dB)	Antenna Height (m)	Table Angle (Degree)	Raw Value (dBuV)	Correction Factor (dB/m)
1	5150.00	59.43 PK	74.00	-14.57	1.01 H	50	49.68	9.75
2	5150.00	50.00 AV	54.00	-4.00	1.01 H	50	40.25	9.75
3	*5190.00	95.39 PK			1.01 H	80	54.07	41.32
4	*5190.00	88.75 AV			1.01 H	80	47.43	41.32
5	5350.00	58.97 PK	74.00	-15.03	1.01 H	80	49.22	9.75
6	5350.00	49.66 AV	54.00	-4.34	1.01 H	80	39.91	9.75
7	#10380.00	58.07 PK	68.20	-10.13	1.14 H	150	43.01	15.06

Antenna Polarity & Test Distance : Vertical at 3 m

No	Frequency (MHz)	Emission Level (dBuV/m)	Limit (dBuV/m)	Margin (dB)	Antenna Height (m)	Table Angle (Degree)	Raw Value (dBuV)	Correction Factor (dB/m)
1	5150.00	59.32 PK	74.00	-14.68	1.81 V	96	49.57	9.75
2	5150.00	49.88 AV	54.00	-4.12	1.81 V	96	40.13	9.75
3	*5190.00	91.18 PK			1.81 V	96	49.86	41.32
4	*5190.00	84.71 AV			1.81 V	96	43.39	41.32
5	5350.00	58.76 PK	74.00	-15.24	1.81 V	96	49.01	9.75
6	5350.00	48.90 AV	54.00	-5.10	1.81 V	96	39.15	9.75
7	#10380.00	57.83 PK	68.20	-10.37	1.15 V	150	42.77	15.06

Remarks:

1. Emission Level(dBuV/m) = Raw Value(dBuV) + Correction Factor(dB/m)
2. Correction Factor(dB/m) = Antenna Factor(dB/m) + Cable Factor(dB) – Pre-Amplifier Factor(dB)
3. Margin value = Emission Level – Limit value
4. The other emission levels were very low against the limit.
5. " * " : Fundamental frequency, the limit was restricted at the RF Output Power.
6. " # " : The radiated frequency is out of the restricted band.



RF Mode	TX 802.11n (HT40)	Channel	CH 46 : 5230 MHz
Frequency Range	1 GHz ~ 40 GHz	Detector Function & Bandwidth	(PK) RB = 1 MHz, VB = 3 MHz (AV) RB = 1 MHz, VB = 3 kHz
Input Power	120 Vac, 60 Hz	Environmental Conditions	25°C, 60% RH
Tested By	Charles Hsiao		

Antenna Polarity & Test Distance : Horizontal at 3 m

No	Frequency (MHz)	Emission Level (dBuV/m)	Limit (dBuV/m)	Margin (dB)	Antenna Height (m)	Table Angle (Degree)	Raw Value (dBuV)	Correction Factor (dB/m)
1	5150.00	59.34 PK	74.00	-14.66	1.01 H	80	49.59	9.75
2	5150.00	49.76 AV	54.00	-4.24	1.01 H	80	40.01	9.75
3	*5230.00	99.29 PK			1.01 H	80	57.92	41.37
4	*5230.00	92.47 AV			1.01 H	80	51.10	41.37
5	5350.00	59.22 PK	74.00	-14.78	1.01 H	80	49.47	9.75
6	5350.00	49.45 AV	54.00	-4.55	1.01 H	80	39.70	9.75
7	#10460.00	58.22 PK	68.20	-9.98	1.13 H	325	43.07	15.15

Antenna Polarity & Test Distance : Vertical at 3 m

No	Frequency (MHz)	Emission Level (dBuV/m)	Limit (dBuV/m)	Margin (dB)	Antenna Height (m)	Table Angle (Degree)	Raw Value (dBuV)	Correction Factor (dB/m)
1	5150.00	59.54 PK	74.00	-14.46	1.90 V	246	49.79	9.75
2	5150.00	49.88 AV	54.00	-4.12	1.90 V	246	40.13	9.75
3	*5230.00	94.16 PK			1.90 V	246	52.79	41.37
4	*5230.00	87.36 AV			1.90 V	246	45.99	41.37
5	5350.00	58.80 PK	74.00	-15.20	1.90 V	246	49.05	9.75
6	5350.00	49.77 AV	54.00	-4.23	1.90 V	246	40.02	9.75
7	#10460.00	58.00 PK	68.20	-10.20	1.11 V	178	42.85	15.15

Remarks:

1. Emission Level(dBuV/m) = Raw Value(dBuV) + Correction Factor(dB/m)
2. Correction Factor(dB/m) = Antenna Factor(dB/m) + Cable Factor(dB) – Pre-Amplifier Factor(dB)
3. Margin value = Emission Level – Limit value
4. The other emission levels were very low against the limit.
5. " * " : Fundamental frequency, the limit was restricted at the RF Output Power.
6. " # " : The radiated frequency is out of the restricted band.

RF Mode	TX 802.11ac (VHT80)	Channel	CH 42 : 5210 MHz
Frequency Range	1 GHz ~ 40 GHz	Detector Function & Bandwidth	(PK) RB = 1 MHz, VB = 3 MHz (AV) RB = 1 MHz, VB = 4 kHz
Input Power	120 Vac, 60 Hz	Environmental Conditions	25°C, 60% RH
Tested By	Charles Hsiao		

Antenna Polarity & Test Distance : Horizontal at 3 m								
No	Frequency (MHz)	Emission Level (dBuV/m)	Limit (dBuV/m)	Margin (dB)	Antenna Height (m)	Table Angle (Degree)	Raw Value (dBuV)	Correction Factor (dB/m)
1	5150.00	58.37 PK	74.00	-15.63	1.32 H	86	48.62	9.75
2	5150.00	48.89 AV	54.00	-5.11	1.32 H	86	39.14	9.75
3	*5210.00	94.27 PK			1.32 H	86	52.91	41.36
4	*5210.00	87.32 AV			1.32 H	86	45.96	41.36
5	5350.00	58.27 PK	74.00	-15.73	1.32 H	86	48.52	9.75
6	5350.00	48.78 AV	54.00	-5.22	1.32 H	86	39.03	9.75
7	#10420.00	56.33 PK	68.20	-11.87	1.16 H	254	41.23	15.10
Antenna Polarity & Test Distance : Vertical at 3 m								
No	Frequency (MHz)	Emission Level (dBuV/m)	Limit (dBuV/m)	Margin (dB)	Antenna Height (m)	Table Angle (Degree)	Raw Value (dBuV)	Correction Factor (dB/m)
1	5150.00	58.25 PK	74.00	-15.75	1.07 V	237	48.50	9.75
2	5150.00	49.76 AV	54.00	-4.24	1.07 V	237	40.01	9.75
3	*5210.00	91.79 PK			1.07 V	237	50.43	41.36
4	*5210.00	84.42 AV			1.07 V	237	43.06	41.36
5	5350.00	58.34 PK	74.00	-15.66	1.07 V	237	48.59	9.75
6	5350.00	48.19 AV	54.00	-5.81	1.07 V	237	38.44	9.75
7	#10420.00	55.78 PK	68.20	-12.42	1.59 V	21	40.68	15.10

Remarks:

1. Emission Level(dBuV/m) = Raw Value(dBuV) + Correction Factor(dB/m)
2. Correction Factor(dB/m) = Antenna Factor(dB/m) + Cable Factor(dB) – Pre-Amplifier Factor(dB)
3. Margin value = Emission Level – Limit value
4. The other emission levels were very low against the limit.
5. " * " : Fundamental frequency, the limit was restricted at the RF Output Power.
6. " # " : The radiated frequency is out of the restricted band.



RF Mode	TX 802.11a	Channel	CH 52 : 5260 MHz
Frequency Range	1 GHz ~ 40 GHz	Detector Function & Bandwidth	(PK) RB = 1 MHz, VB = 3 MHz (AV) RB = 1 MHz, VB = 1 kHz
Input Power	120 Vac, 60 Hz	Environmental Conditions	25°C, 60% RH
Tested By	Charles Hsiao		

Antenna Polarity & Test Distance : Horizontal at 3 m

No	Frequency (MHz)	Emission Level (dBuV/m)	Limit (dBuV/m)	Margin (dB)	Antenna Height (m)	Table Angle (Degree)	Raw Value (dBuV)	Correction Factor (dB/m)
1	5150.00	58.33 PK	74.00	-15.67	1.24 H	87	48.58	9.75
2	5150.00	48.11 AV	54.00	-5.89	1.24 H	87	38.36	9.75
3	*5260.00	104.41 PK			1.24 H	87	63.05	41.36
4	*5260.00	97.55 AV			1.24 H	87	56.19	41.36
5	#10520.00	56.59 PK	68.20	-11.61	1.31 H	271	41.44	15.15

Antenna Polarity & Test Distance : Vertical at 3 m

No	Frequency (MHz)	Emission Level (dBuV/m)	Limit (dBuV/m)	Margin (dB)	Antenna Height (m)	Table Angle (Degree)	Raw Value (dBuV)	Correction Factor (dB/m)
1	5150.00	58.44 PK	74.00	-15.56	1.26 V	267	48.69	9.75
2	5150.00	48.30 AV	54.00	-5.70	1.26 V	267	38.55	9.75
3	*5260.00	102.19 PK			1.26 V	267	60.83	41.36
4	*5260.00	94.99 AV			1.26 V	267	53.63	41.36
5	#10520.00	56.61 PK	68.20	-11.59	1.73 V	214	41.46	15.15

Remarks:

1. Emission Level(dBuV/m) = Raw Value(dBuV) + Correction Factor(dB/m)
2. Correction Factor(dB/m) = Antenna Factor(dB/m) + Cable Factor(dB) – Pre-Amplifier Factor(dB)
3. Margin value = Emission Level – Limit value
4. The other emission levels were very low against the limit.
5. " * ": Fundamental frequency, the limit was restricted at the RF Output Power.
6. " # ": The radiated frequency is out of the restricted band.



RF Mode	TX 802.11a	Channel	CH 60 : 5300 MHz
Frequency Range	1 GHz ~ 40 GHz	Detector Function & Bandwidth	(PK) RB = 1 MHz, VB = 3 MHz (AV) RB = 1 MHz, VB = 1 kHz
Input Power	120 Vac, 60 Hz	Environmental Conditions	25°C, 60% RH
Tested By	Charles Hsiao		

Antenna Polarity & Test Distance : Horizontal at 3 m								
No	Frequency (MHz)	Emission Level (dBuV/m)	Limit (dBuV/m)	Margin (dB)	Antenna Height (m)	Table Angle (Degree)	Raw Value (dBuV)	Correction Factor (dB/m)
1	5150.00	58.32 PK	74.00	-15.68	1.24 H	87	48.57	9.75
2	5150.00	48.07 AV	54.00	-5.93	1.24 H	87	38.32	9.75
3	*5300.00	104.35 PK			1.24 H	87	63.05	41.30
4	*5300.00	97.83 AV			1.24 H	87	56.53	41.30
5	5350.00	58.36 PK	74.00	-15.64	1.24 H	87	48.61	9.75
6	5350.00	48.30 AV	54.00	-5.70	1.24 H	87	38.55	9.75
7	10600.00	56.19 PK	74.00	-17.81	N/A H	N/A	41.27	14.92
8	10600.00	46.52 AV	54.00	-7.48	N/A H	N/A	31.60	14.92

Antenna Polarity & Test Distance : Vertical at 3 m								
No	Frequency (MHz)	Emission Level (dBuV/m)	Limit (dBuV/m)	Margin (dB)	Antenna Height (m)	Table Angle (Degree)	Raw Value (dBuV)	Correction Factor (dB/m)
1	5150.00	58.54 PK	74.00	-15.46	1.04 V	231	48.79	9.75
2	5150.00	47.99 AV	54.00	-6.01	1.04 V	231	38.24	9.75
3	*5300.00	102.53 PK			1.04 V	231	61.23	41.30
4	*5300.00	95.25 AV			1.04 V	231	53.95	41.30
5	5350.00	58.40 PK	74.00	-15.60	1.04 V	231	48.65	9.75
6	5350.00	47.91 AV	54.00	-6.09	1.04 V	231	38.16	9.75
7	10600.00	56.31 PK	74.00	-17.69	1.59 V	27	41.39	14.92
8	10600.00	46.14 AV	54.00	-7.86	1.59 V	27	31.22	14.92

Remarks:

1. Emission Level(dBuV/m) = Raw Value(dBuV) + Correction Factor(dB/m)
2. Correction Factor(dB/m) = Antenna Factor(dB/m) + Cable Factor(dB) – Pre-Amplifier Factor(dB)
3. Margin value = Emission Level – Limit value
4. The other emission levels were very low against the limit.
5. " * ": Fundamental frequency, the limit was restricted at the RF Output Power.



RF Mode	TX 802.11a	Channel	CH 64 : 5320 MHz
Frequency Range	1 GHz ~ 40 GHz	Detector Function & Bandwidth	(PK) RB = 1 MHz, VB = 3 MHz (AV) RB = 1 MHz, VB = 1 kHz
Input Power	120 Vac, 60 Hz	Environmental Conditions	25°C, 60% RH
Tested By	Charles Hsiao		

Antenna Polarity & Test Distance : Horizontal at 3 m

No	Frequency (MHz)	Emission Level (dBuV/m)	Limit (dBuV/m)	Margin (dB)	Antenna Height (m)	Table Angle (Degree)	Raw Value (dBuV)	Correction Factor (dB/m)
1	*5320.00	101.89 PK			1.44 H	86	60.59	41.30
2	*5320.00	95.87 AV			1.44 H	86	54.57	41.30
3	5350.00	59.27 PK	74.00	-14.73	1.44 H	86	49.52	9.75
4	5350.00	49.97 AV	54.00	-4.03	1.44 H	86	40.22	9.75
5	10640.00	56.51 PK	74.00	-17.49	2.26 H	172	41.41	15.10
6	10640.00	46.88 AV	54.00	-7.12	2.26 H	172	31.78	15.10

Antenna Polarity & Test Distance : Vertical at 3 m

No	Frequency (MHz)	Emission Level (dBuV/m)	Limit (dBuV/m)	Margin (dB)	Antenna Height (m)	Table Angle (Degree)	Raw Value (dBuV)	Correction Factor (dB/m)
1	*5320.00	99.43 PK			1.79 V	231	58.13	41.30
2	*5320.00	92.61 AV			1.79 V	231	51.31	41.30
3	5350.00	58.56 PK	74.00	-15.44	1.79 V	231	48.81	9.75
4	5350.00	48.53 AV	54.00	-5.47	1.79 V	231	38.78	9.75
5	10640.00	56.51 PK	74.00	-17.49	2.43 V	109	41.41	15.10
6	10640.00	46.88 AV	54.00	-7.12	2.43 V	109	31.78	15.10

Remarks:

1. Emission Level(dBuV/m) = Raw Value(dBuV) + Correction Factor(dB/m)
2. Correction Factor(dB/m) = Antenna Factor(dB/m) + Cable Factor(dB) – Pre-Amplifier Factor(dB)
3. Margin value = Emission Level – Limit value
4. The other emission levels were very low against the limit.
5. " * ": Fundamental frequency, the limit was restricted at the RF Output Power.



RF Mode	TX 802.11n (HT20)	Channel	CH 52 : 5260 MHz
Frequency Range	1 GHz ~ 40 GHz	Detector Function & Bandwidth	(PK) RB = 1 MHz, VB = 3 MHz (AV) RB = 1 MHz, VB = 1 kHz
Input Power	120 Vac, 60 Hz	Environmental Conditions	25°C, 60% RH
Tested By	Charles Hsiao		

Antenna Polarity & Test Distance : Horizontal at 3 m								
No	Frequency (MHz)	Emission Level (dBuV/m)	Limit (dBuV/m)	Margin (dB)	Antenna Height (m)	Table Angle (Degree)	Raw Value (dBuV)	Correction Factor (dB/m)
1	5150.00	58.16 PK	74.00	-15.84	1.24 H	87	48.41	9.75
2	5150.00	48.07 AV	54.00	-5.93	1.24 H	87	38.32	9.75
3	*5260.00	104.07 PK			1.24 H	87	62.71	41.36
4	*5260.00	96.00 AV			1.24 H	87	54.64	41.36
5	#10520.00	56.08 PK	68.20	-12.12	2.53 H	108	40.93	15.15

Antenna Polarity & Test Distance : Vertical at 3 m								
No	Frequency (MHz)	Emission Level (dBuV/m)	Limit (dBuV/m)	Margin (dB)	Antenna Height (m)	Table Angle (Degree)	Raw Value (dBuV)	Correction Factor (dB/m)
1	5150.00	58.17 PK	74.00	-15.83	1.26 V	267	48.42	9.75
2	5150.00	48.04 AV	54.00	-5.96	1.26 V	267	38.29	9.75
3	*5260.00	102.31 PK			1.26 V	267	60.95	41.36
4	*5260.00	94.41 AV			1.26 V	267	53.05	41.36
5	#10520.00	56.46 PK	68.20	-11.74	1.61 V	28	41.31	15.15

Remarks:

1. Emission Level(dBuV/m) = Raw Value(dBuV) + Correction Factor(dB/m)
2. Correction Factor(dB/m) = Antenna Factor(dB/m) + Cable Factor(dB) – Pre-Amplifier Factor(dB)
3. Margin value = Emission Level – Limit value
4. The other emission levels were very low against the limit.
5. " * ": Fundamental frequency, the limit was restricted at the RF Output Power.
6. " # ": The radiated frequency is out of the restricted band.



RF Mode	TX 802.11n (HT20)	Channel	CH 60 : 5300 MHz
Frequency Range	1 GHz ~ 40 GHz	Detector Function & Bandwidth	(PK) RB = 1 MHz, VB = 3 MHz (AV) RB = 1 MHz, VB = 1 kHz
Input Power	120 Vac, 60 Hz	Environmental Conditions	25°C, 60% RH
Tested By	Charles Hsiao		

Antenna Polarity & Test Distance : Horizontal at 3 m

No	Frequency (MHz)	Emission Level (dBuV/m)	Limit (dBuV/m)	Margin (dB)	Antenna Height (m)	Table Angle (Degree)	Raw Value (dBuV)	Correction Factor (dB/m)
1	5150.00	58.47 PK	74.00	-15.53	1.24 H	87	48.72	9.75
2	5150.00	48.28 AV	54.00	-5.72	1.24 H	87	38.53	9.75
3	*5300.00	104.04 PK			1.24 H	87	62.74	41.30
4	*5300.00	96.93 AV			1.24 H	87	55.63	41.30
5	5350.00	58.35 PK	74.00	-15.65	1.24 H	87	48.60	9.75
6	5350.00	48.28 AV	54.00	-5.72	1.24 H	87	38.53	9.75
7	10600.00	55.71 PK	74.00	-18.29	1.82 H	62	40.79	14.92
8	10600.00	46.08 AV	54.00	-7.92	1.82 H	62	31.16	14.92

Antenna Polarity & Test Distance : Vertical at 3 m

No	Frequency (MHz)	Emission Level (dBuV/m)	Limit (dBuV/m)	Margin (dB)	Antenna Height (m)	Table Angle (Degree)	Raw Value (dBuV)	Correction Factor (dB/m)
1	5150.00	58.24 PK	74.00	-15.76	1.29 V	245	48.49	9.75
2	5150.00	48.00 AV	54.00	-6.00	1.29 V	245	38.25	9.75
3	*5300.00	101.45 PK			1.29 V	245	60.15	41.30
4	*5300.00	94.17 AV			1.29 V	245	52.87	41.30
5	5350.00	58.46 PK	74.00	-15.54	1.29 V	245	48.71	9.75
6	5350.00	48.25 AV	54.00	-5.75	1.29 V	245	38.50	9.75
7	10600.00	56.04 PK	74.00	-17.96	2.68 V	93	41.12	14.92
8	10600.00	46.35 AV	54.00	-7.65	2.68 V	93	31.43	14.92

Remarks:

1. Emission Level(dBuV/m) = Raw Value(dBuV) + Correction Factor(dB/m)
2. Correction Factor(dB/m) = Antenna Factor(dB/m) + Cable Factor(dB) – Pre-Amplifier Factor(dB)
3. Margin value = Emission Level – Limit value
4. The other emission levels were very low against the limit.
5. " * ": Fundamental frequency, the limit was restricted at the RF Output Power.



RF Mode	TX 802.11n (HT20)	Channel	CH 64 : 5320 MHz
Frequency Range	1 GHz ~ 40 GHz	Detector Function & Bandwidth	(PK) RB = 1 MHz, VB = 3 MHz (AV) RB = 1 MHz, VB = 1 kHz
Input Power	120 Vac, 60 Hz	Environmental Conditions	25°C, 60% RH
Tested By	Charles Hsiao		

Antenna Polarity & Test Distance : Horizontal at 3 m								
No	Frequency (MHz)	Emission Level (dBuV/m)	Limit (dBuV/m)	Margin (dB)	Antenna Height (m)	Table Angle (Degree)	Raw Value (dBuV)	Correction Factor (dB/m)
1	*5320.00	103.54 PK			1.44 H	86	62.24	41.30
2	*5320.00	95.65 AV			1.44 H	86	54.35	41.30
3	5350.00	58.91 PK	74.00	-15.09	1.44 H	86	49.16	9.75
4	5350.00	49.01 AV	54.00	-4.99	1.44 H	86	39.26	9.75
5	10640.00	56.37 PK	74.00	-17.63	1.84 H	172	41.27	15.10
6	10640.00	46.75 AV	54.00	-7.25	1.84 H	172	31.65	15.10
Antenna Polarity & Test Distance : Vertical at 3 m								
No	Frequency (MHz)	Emission Level (dBuV/m)	Limit (dBuV/m)	Margin (dB)	Antenna Height (m)	Table Angle (Degree)	Raw Value (dBuV)	Correction Factor (dB/m)
1	*5320.00	99.80 PK			1.86 V	230	58.50	41.30
2	*5320.00	92.87 AV			1.86 V	230	51.57	41.30
3	5350.00	58.66 PK	74.00	-15.34	1.86 V	231	48.91	9.75
4	5350.00	48.90 AV	54.00	-5.10	1.86 V	231	39.15	9.75
5	10640.00	56.18 PK	74.00	-17.82	1.37 V	232	41.08	15.10
6	10640.00	46.52 AV	54.00	-7.48	1.37 V	232	31.42	15.10

Remarks:

1. Emission Level(dBuV/m) = Raw Value(dBuV) + Correction Factor(dB/m)
2. Correction Factor(dB/m) = Antenna Factor(dB/m) + Cable Factor(dB) – Pre-Amplifier Factor(dB)
3. Margin value = Emission Level – Limit value
4. The other emission levels were very low against the limit.
5. " * ": Fundamental frequency, the limit was restricted at the RF Output Power.



RF Mode	TX 802.11n (HT40)	Channel	CH 54 : 5270 MHz
Frequency Range	1 GHz ~ 40 GHz	Detector Function & Bandwidth	(PK) RB = 1 MHz, VB = 3 MHz (AV) RB = 1 MHz, VB = 2 kHz
Input Power	120 Vac, 60 Hz	Environmental Conditions	25°C, 60% RH
Tested By	Charles Hsiao		

Antenna Polarity & Test Distance : Horizontal at 3 m

No	Frequency (MHz)	Emission Level (dBuV/m)	Limit (dBuV/m)	Margin (dB)	Antenna Height (m)	Table Angle (Degree)	Raw Value (dBuV)	Correction Factor (dB/m)
1	5150.00	58.16 PK	74.00	-15.84	1.27 H	86	48.41	9.75
2	5150.00	48.06 AV	54.00	-5.94	1.27 H	86	38.31	9.75
3	*5270.00	101.72 PK			1.27 H	86	60.37	41.35
4	*5270.00	94.91 AV			1.27 H	86	53.56	41.35
5	5350.00	58.28 PK	74.00	-15.72	1.27 H	86	48.53	9.75
6	5350.00	48.12 AV	54.00	-5.88	1.27 H	86	38.37	9.75
7	#10540.00	56.35 PK	68.20	-11.85	1.09 H	58	41.26	15.09

Antenna Polarity & Test Distance : Vertical at 3 m

No	Frequency (MHz)	Emission Level (dBuV/m)	Limit (dBuV/m)	Margin (dB)	Antenna Height (m)	Table Angle (Degree)	Raw Value (dBuV)	Correction Factor (dB/m)
1	5150.00	58.29 PK	74.00	-15.71	1.26 V	267	48.54	9.75
2	5150.00	48.37 AV	54.00	-5.63	1.26 V	267	38.62	9.75
3	*5270.00	98.71 PK			1.26 V	267	57.36	41.35
4	*5270.00	92.17 AV			1.26 V	267	50.82	41.35
5	5350.00	58.11 PK	74.00	-15.89	1.26 V	267	48.36	9.75
6	5350.00	48.30 AV	54.00	-5.70	1.26 V	267	38.55	9.75
7	#10540.00	55.75 PK	68.20	-12.45	1.02 V	342	40.66	15.09

Remarks:

1. Emission Level(dBuV/m) = Raw Value(dBuV) + Correction Factor(dB/m)
2. Correction Factor(dB/m) = Antenna Factor(dB/m) + Cable Factor(dB) – Pre-Amplifier Factor(dB)
3. Margin value = Emission Level – Limit value
4. The other emission levels were very low against the limit.
5. " * " : Fundamental frequency, the limit was restricted at the RF Output Power.
6. " # " : The radiated frequency is out of the restricted band.

RF Mode	TX 802.11n (HT40)	Channel	CH 62 : 5310 MHz
Frequency Range	1 GHz ~ 40 GHz	Detector Function & Bandwidth	(PK) RB = 1 MHz, VB = 3 MHz (AV) RB = 1 MHz, VB = 2 kHz
Input Power	120 Vac, 60 Hz	Environmental Conditions	25°C, 60% RH
Tested By	Charles Hsiao		

Antenna Polarity & Test Distance : Horizontal at 3 m								
No	Frequency (MHz)	Emission Level (dBuV/m)	Limit (dBuV/m)	Margin (dB)	Antenna Height (m)	Table Angle (Degree)	Raw Value (dBuV)	Correction Factor (dB/m)
1	5150.00	58.50 PK	74.00	-15.50	1.44 H	86	48.75	9.75
2	5150.00	48.59 AV	54.00	-5.41	1.44 H	86	38.84	9.75
3	*5310.00	96.90 PK			1.44 H	86	55.60	41.30
4	*5310.00	90.08 AV			1.44 H	86	48.78	41.30
5	5350.00	58.74 PK	74.00	-15.26	1.44 H	86	48.99	9.75
6	5350.00	48.97 AV	54.00	-5.03	1.44 H	86	39.22	9.75
7	10620.00	56.35 PK	74.00	-17.65	3.14 H	172	41.35	15.00
8	10620.00	46.68 AV	54.00	-7.32	3.14 H	172	31.68	15.00
Antenna Polarity & Test Distance : Vertical at 3 m								
No	Frequency (MHz)	Emission Level (dBuV/m)	Limit (dBuV/m)	Margin (dB)	Antenna Height (m)	Table Angle (Degree)	Raw Value (dBuV)	Correction Factor (dB/m)
1	5150.00	58.39 PK	74.00	-15.61	1.86 V	230	48.64	9.75
2	5150.00	48.17 AV	54.00	-5.83	1.86 V	230	38.42	9.75
3	*5310.00	94.08 PK			1.86 V	230	52.78	41.30
4	*5310.00	87.16 AV			1.86 V	230	45.86	41.30
5	5350.00	58.82 PK	74.00	-15.18	1.86 V	230	49.07	9.75
6	5350.00	49.19 AV	54.00	-4.81	1.86 V	230	39.44	9.75
7	10620.00	55.54 PK	74.00	-18.46	2.41 V	267	40.54	15.00
8	10620.00	45.89 AV	54.00	-8.11	2.41 V	267	30.89	15.00

Remarks:

1. Emission Level(dBuV/m) = Raw Value(dBuV) + Correction Factor(dB/m)
2. Correction Factor(dB/m) = Antenna Factor(dB/m) + Cable Factor(dB) – Pre-Amplifier Factor(dB)
3. Margin value = Emission Level – Limit value
4. The other emission levels were very low against the limit.
5. " * " : Fundamental frequency, the limit was restricted at the RF Output Power.



RF Mode	TX 802.11ac (VHT80)	Channel	CH 58 : 5290 MHz
Frequency Range	1 GHz ~ 40 GHz	Detector Function & Bandwidth	(PK) RB = 1 MHz, VB = 3 MHz (AV) RB = 1 MHz, VB = 4 kHz
Input Power	120 Vac, 60 Hz	Environmental Conditions	25°C, 60% RH
Tested By	Charles Hsiao		

Antenna Polarity & Test Distance : Horizontal at 3 m

No	Frequency (MHz)	Emission Level (dBuV/m)	Limit (dBuV/m)	Margin (dB)	Antenna Height (m)	Table Angle (Degree)	Raw Value (dBuV)	Correction Factor (dB/m)
1	5150.00	58.32 PK	74.00	-15.68	1.24 H	87	48.57	9.75
2	5150.00	48.66 AV	54.00	-5.34	1.24 H	87	38.91	9.75
3	*5290.00	93.92 PK			1.24 H	87	52.60	41.32
4	*5290.00	86.90 AV			1.24 H	87	45.58	41.32
5	5350.00	58.73 PK	74.00	-15.27	1.24 H	87	48.98	9.75
6	5350.00	49.01 AV	54.00	-4.99	1.24 H	87	39.26	9.75
7	#10580.00	55.83 PK	68.20	-12.37	1.28 H	173	40.85	14.98

Antenna Polarity & Test Distance : Vertical at 3 m

No	Frequency (MHz)	Emission Level (dBuV/m)	Limit (dBuV/m)	Margin (dB)	Antenna Height (m)	Table Angle (Degree)	Raw Value (dBuV)	Correction Factor (dB/m)
1	5150.00	58.49 PK	74.00	-15.51	1.07 V	237	48.74	9.75
2	5150.00	48.58 AV	54.00	-5.42	1.07 V	237	38.83	9.75
3	*5290.00	91.72 PK			1.07 V	237	50.40	41.32
4	*5290.00	84.27 AV			1.07 V	237	42.95	41.32
5	5350.00	58.79 PK	74.00	-15.21	1.07 V	237	49.04	9.75
6	5350.00	48.96 AV	54.00	-5.04	1.07 V	237	39.21	9.75
7	#10580.00	55.80 PK	68.20	-12.40	1.29 V	347	40.82	14.98

Remarks:

1. Emission Level(dBuV/m) = Raw Value(dBuV) + Correction Factor(dB/m)
2. Correction Factor(dB/m) = Antenna Factor(dB/m) + Cable Factor(dB) – Pre-Amplifier Factor(dB)
3. Margin value = Emission Level – Limit value
4. The other emission levels were very low against the limit.
5. " * " : Fundamental frequency, the limit was restricted at the RF Output Power.
6. " # " : The radiated frequency is out of the restricted band.



RF Mode	TX 802.11a	Channel	CH 100 : 5500 MHz
Frequency Range	1 GHz ~ 40 GHz	Detector Function & Bandwidth	(PK) RB = 1 MHz, VB = 3 MHz (AV) RB = 1 MHz, VB = 1 kHz
Input Power	120 Vac, 60 Hz	Environmental Conditions	25°C, 60% RH
Tested By	Charles Hsiao		

Antenna Polarity & Test Distance : Horizontal at 3 m								
No	Frequency (MHz)	Emission Level (dBuV/m)	Limit (dBuV/m)	Margin (dB)	Antenna Height (m)	Table Angle (Degree)	Raw Value (dBuV)	Correction Factor (dB/m)
1	5460.00	58.09 PK	74.00	-15.91	2.08 H	82	48.45	9.64
2	5460.00	49.09 AV	54.00	-4.91	2.08 H	82	39.45	9.64
3	#5470.00	60.32 PK	68.20	-7.88	2.08 H	82	50.76	9.56
4	*5500.00	103.16 PK			2.08 H	82	61.91	41.25
5	*5500.00	96.48 AV			2.08 H	82	55.23	41.25
6	11000.00	57.06 PK	74.00	-16.94	1.61 H	114	41.29	15.77
7	11000.00	47.31 AV	54.00	-6.69	1.61 H	114	31.54	15.77
Antenna Polarity & Test Distance : Vertical at 3 m								
No	Frequency (MHz)	Emission Level (dBuV/m)	Limit (dBuV/m)	Margin (dB)	Antenna Height (m)	Table Angle (Degree)	Raw Value (dBuV)	Correction Factor (dB/m)
1	5460.00	58.25 PK	74.00	-15.75	1.99 V	220	48.61	9.64
2	5460.00	49.10 AV	54.00	-4.90	1.99 V	220	39.46	9.64
3	#5470.00	58.90 PK	68.20	-9.30	1.99 V	220	49.34	9.56
4	*5500.00	101.51 PK			1.99 V	220	60.26	41.25
5	*5500.00	94.73 AV			1.99 V	220	53.48	41.25
6	11000.00	56.26 PK	74.00	-17.74	2.05 V	216	40.49	15.77
7	11000.00	46.54 AV	54.00	-7.46	2.05 V	216	30.77	15.77

Remarks:

1. Emission Level(dBuV/m) = Raw Value(dBuV) + Correction Factor(dB/m)
2. Correction Factor(dB/m) = Antenna Factor(dB/m) + Cable Factor(dB) – Pre-Amplifier Factor(dB)
3. Margin value = Emission Level – Limit value
4. The other emission levels were very low against the limit.
5. " * " : Fundamental frequency, the limit was restricted at the RF Output Power.
6. " # " : The radiated frequency is out of the restricted band.



RF Mode	TX 802.11a	Channel	CH 116 : 5580 MHz
Frequency Range	1 GHz ~ 40 GHz	Detector Function & Bandwidth	(PK) RB = 1 MHz, VB = 3 MHz (AV) RB = 1 MHz, VB = 1 kHz
Input Power	120 Vac, 60 Hz	Environmental Conditions	25°C, 60% RH
Tested By	Charles Hsiao		

Antenna Polarity & Test Distance : Horizontal at 3 m

No	Frequency (MHz)	Emission Level (dBuV/m)	Limit (dBuV/m)	Margin (dB)	Antenna Height (m)	Table Angle (Degree)	Raw Value (dBuV)	Correction Factor (dB/m)
1	5460.00	58.22 PK	74.00	-15.78	2.10 H	84	48.58	9.64
2	5460.00	48.65 AV	54.00	-5.35	2.10 H	84	39.01	9.64
3	#5470.00	58.08 PK	68.20	-10.12	2.10 H	84	48.52	9.56
4	*5580.00	105.47 PK			2.10 H	84	64.20	41.27
5	*5580.00	98.92 AV			2.10 H	84	57.65	41.27
6	#5725.00	58.43 PK	68.20	-9.77	2.10 H	84	48.33	10.10
7	11160.00	56.68 PK	74.00	-17.32	2.82 H	162	40.87	15.81
8	11160.00	46.87 AV	54.00	-7.13	2.82 H	162	31.06	15.81

Antenna Polarity & Test Distance : Vertical at 3 m

No	Frequency (MHz)	Emission Level (dBuV/m)	Limit (dBuV/m)	Margin (dB)	Antenna Height (m)	Table Angle (Degree)	Raw Value (dBuV)	Correction Factor (dB/m)
1	5460.00	58.01 PK	74.00	-15.99	1.96 V	207	48.37	9.64
2	5460.00	47.86 AV	54.00	-6.14	1.96 V	207	38.22	9.64
3	#5470.00	58.09 PK	68.20	-10.11	1.96 V	207	48.53	9.56
4	*5580.00	103.82 PK			1.96 V	207	62.55	41.27
5	*5580.00	97.11 AV			1.96 V	207	55.84	41.27
6	#5725.00	58.72 PK	68.20	-9.48	1.96 V	207	48.62	10.10
7	11160.00	56.07 PK	74.00	-17.93	1.12 V	49	40.26	15.81
8	11160.00	46.42 AV	54.00	-7.58	1.12 V	49	30.61	15.81

Remarks:

1. Emission Level(dBuV/m) = Raw Value(dBuV) + Correction Factor(dB/m)
2. Correction Factor(dB/m) = Antenna Factor(dB/m) + Cable Factor(dB) – Pre-Amplifier Factor(dB)
3. Margin value = Emission Level – Limit value
4. The other emission levels were very low against the limit.
5. " * ": Fundamental frequency, the limit was restricted at the RF Output Power.
6. " # ": The radiated frequency is out of the restricted band.



RF Mode	TX 802.11a	Channel	CH 140 : 5700 MHz
Frequency Range	1 GHz ~ 40 GHz	Detector Function & Bandwidth	(PK) RB = 1 MHz, VB = 3 MHz (AV) RB = 1 MHz, VB = 1 kHz
Input Power	120 Vac, 60 Hz	Environmental Conditions	25°C, 60% RH
Tested By	Charles Hsiao		

Antenna Polarity & Test Distance : Horizontal at 3 m

No	Frequency (MHz)	Emission Level (dBuV/m)	Limit (dBuV/m)	Margin (dB)	Antenna Height (m)	Table Angle (Degree)	Raw Value (dBuV)	Correction Factor (dB/m)
1	*5700.00	103.02 PK			2.06 H	80	61.52	41.50
2	*5700.00	96.11 AV			2.06 H	80	54.61	41.50
3	#5725.00	60.70 PK	68.20	-7.50	2.06 H	80	50.60	10.10
4	11400.00	55.84 PK	74.00	-18.16	1.83 H	123	40.51	15.33
5	11400.00	46.21 AV	54.00	-7.79	1.83 H	123	30.88	15.33

Antenna Polarity & Test Distance : Vertical at 3 m

No	Frequency (MHz)	Emission Level (dBuV/m)	Limit (dBuV/m)	Margin (dB)	Antenna Height (m)	Table Angle (Degree)	Raw Value (dBuV)	Correction Factor (dB/m)
1	*5700.00	101.96 PK			2.25 V	241	60.46	41.50
2	*5700.00	95.13 AV			2.25 V	241	53.63	41.50
3	#5725.00	60.21 PK	68.20	-7.99	2.25 V	241	50.11	10.10
4	11400.00	56.71 PK	74.00	-17.29	2.42 V	193	41.38	15.33
5	11400.00	47.41 AV	54.00	-6.59	2.42 V	193	32.08	15.33

Remarks:

1. Emission Level(dBuV/m) = Raw Value(dBuV) + Correction Factor(dB/m)
2. Correction Factor(dB/m) = Antenna Factor(dB/m) + Cable Factor(dB) – Pre-Amplifier Factor(dB)
3. Margin value = Emission Level – Limit value
4. The other emission levels were very low against the limit.
5. " * ": Fundamental frequency, the limit was restricted at the RF Output Power.
6. " # ": The radiated frequency is out of the restricted band.

RF Mode	TX 802.11a	Channel	CH 144 : 5720 MHz
Frequency Range	1 GHz ~ 40 GHz	Detector Function & Bandwidth	(PK) RB = 1 MHz, VB = 3 MHz (AV) RB = 1 MHz, VB = 1 kHz
Input Power	120 Vac, 60 Hz	Environmental Conditions	25°C, 60% RH
Tested By	Karl Lee		

Antenna Polarity & Test Distance : Horizontal at 3 m								
No	Frequency (MHz)	Emission Level (dBuV/m)	Limit (dBuV/m)	Margin (dB)	Antenna Height (m)	Table Angle (Degree)	Raw Value (dBuV)	Correction Factor (dB/m)
1	5460.00	54.17 PK	74.00	-19.83	2.21 H	80	41.45	12.72
2	5460.00	47.85 AV	54.00	-6.15	2.21 H	80	35.13	12.72
3	#5470.00	58.21 PK	68.20	-9.99	2.21 H	80	45.48	12.73
4	*5720.00	106.92 PK			2.21 H	80	63.38	43.54
5	*5720.00	99.38 AV			2.21 H	80	55.84	43.54
6	11440.00	58.97 PK	74.00	-15.03	1.21 H	248	40.33	18.64
7	11440.00	49.18 AV	54.00	-4.82	1.21 H	248	30.54	18.64
Antenna Polarity & Test Distance : Vertical at 3 m								
No	Frequency (MHz)	Emission Level (dBuV/m)	Limit (dBuV/m)	Margin (dB)	Antenna Height (m)	Table Angle (Degree)	Raw Value (dBuV)	Correction Factor (dB/m)
1	5460.00	54.41 PK	74.00	-19.59	2.84 V	181	41.69	12.72
2	5460.00	47.16 AV	54.00	-6.84	2.84 V	181	34.44	12.72
3	#5470.00	57.82 PK	68.20	-10.38	2.84 V	181	45.09	12.73
4	*5720.00	101.46 PK			2.84 V	181	57.92	43.54
5	*5720.00	94.49 AV			2.84 V	181	50.95	43.54
6	11440.00	58.88 PK	74.00	-15.12	1.36 V	125	40.24	18.64
7	11440.00	49.19 AV	54.00	-4.81	1.36 V	125	30.55	18.64

Remarks:

1. Emission Level(dBuV/m) = Raw Value(dBuV) + Correction Factor(dB/m)
2. Correction Factor(dB/m) = Antenna Factor(dB/m) + Cable Factor(dB) – Pre-Amplifier Factor(dB)
3. Margin value = Emission Level – Limit value
4. The other emission levels were very low against the limit.
5. " * ": Fundamental frequency, the limit was restricted at the RF Output Power.
6. " # ": The radiated frequency is out of the restricted band.



RF Mode	TX 802.11n (HT20)	Channel	CH 100 : 5500 MHz
Frequency Range	1 GHz ~ 40 GHz	Detector Function & Bandwidth	(PK) RB = 1 MHz, VB = 3 MHz (AV) RB = 1 MHz, VB = 1 kHz
Input Power	120 Vac, 60 Hz	Environmental Conditions	25°C, 60% RH
Tested By	Charles Hsiao		

Antenna Polarity & Test Distance : Horizontal at 3 m

No	Frequency (MHz)	Emission Level (dBuV/m)	Limit (dBuV/m)	Margin (dB)	Antenna Height (m)	Table Angle (Degree)	Raw Value (dBuV)	Correction Factor (dB/m)
1	5460.00	60.24 PK	74.00	-13.76	2.08 H	82	50.60	9.64
2	5460.00	50.05 AV	54.00	-3.95	2.08 H	82	40.41	9.64
3	#5470.00	60.55 PK	68.20	-7.65	2.08 H	82	50.99	9.56
4	*5500.00	101.54 PK			2.08 H	82	60.29	41.25
5	*5500.00	94.56 AV			2.08 H	82	53.31	41.25
6	11000.00	58.14 PK	74.00	-15.86	1.04 H	45	42.37	15.77
7	11000.00	48.36 AV	54.00	-5.64	1.04 H	45	32.59	15.77

Antenna Polarity & Test Distance : Vertical at 3 m

No	Frequency (MHz)	Emission Level (dBuV/m)	Limit (dBuV/m)	Margin (dB)	Antenna Height (m)	Table Angle (Degree)	Raw Value (dBuV)	Correction Factor (dB/m)
1	5460.00	59.98 PK	74.00	-14.02	1.99 V	220	50.34	9.64
2	5460.00	49.87 AV	54.00	-4.13	1.99 V	220	40.23	9.64
3	#5470.00	60.13 PK	68.20	-8.07	1.99 V	220	50.57	9.56
4	*5500.00	98.17 PK			1.99 V	220	56.92	41.25
5	*5500.00	91.46 AV			1.99 V	220	50.21	41.25
6	11000.00	58.07 PK	74.00	-15.93	1.57 V	32	42.30	15.77
7	11000.00	48.10 AV	54.00	-5.90	1.57 V	32	32.33	15.77

Remarks:

1. Emission Level(dBuV/m) = Raw Value(dBuV) + Correction Factor(dB/m)
2. Correction Factor(dB/m) = Antenna Factor(dB/m) + Cable Factor(dB) – Pre-Amplifier Factor(dB)
3. Margin value = Emission Level – Limit value
4. The other emission levels were very low against the limit.
5. " * " : Fundamental frequency, the limit was restricted at the RF Output Power.
6. " # " : The radiated frequency is out of the restricted band.



RF Mode	TX 802.11n (HT20)	Channel	CH 116 : 5580 MHz
Frequency Range	1 GHz ~ 40 GHz	Detector Function & Bandwidth	(PK) RB = 1 MHz, VB = 3 MHz (AV) RB = 1 MHz, VB = 1 kHz
Input Power	120 Vac, 60 Hz	Environmental Conditions	25°C, 60% RH
Tested By	Charles Hsiao		

Antenna Polarity & Test Distance : Horizontal at 3 m								
No	Frequency (MHz)	Emission Level (dBuV/m)	Limit (dBuV/m)	Margin (dB)	Antenna Height (m)	Table Angle (Degree)	Raw Value (dBuV)	Correction Factor (dB/m)
1	*5580.00	102.69 PK			2.08 H	82	61.42	41.27
2	*5580.00	95.35 AV			2.08 H	82	54.08	41.27
3	11160.00	57.13 PK	74.00	-16.87	1.15 H	54	41.32	15.81
4	11160.00	47.90 AV	54.00	-6.10	1.15 H	54	32.09	15.81

Antenna Polarity & Test Distance : Vertical at 3 m								
No	Frequency (MHz)	Emission Level (dBuV/m)	Limit (dBuV/m)	Margin (dB)	Antenna Height (m)	Table Angle (Degree)	Raw Value (dBuV)	Correction Factor (dB/m)
1	*5580.00	100.07 PK			1.99 V	208	58.80	41.27
2	*5580.00	93.37 AV			1.99 V	208	52.10	41.27
3	11160.00	56.51 PK	74.00	-17.49	1.15 V	54	40.70	15.81
4	11160.00	47.85 AV	54.00	-6.15	1.15 V	54	32.04	15.81

Remarks:

1. Emission Level(dBuV/m) = Raw Value(dBuV) + Correction Factor(dB/m)
2. Correction Factor(dB/m) = Antenna Factor(dB/m) + Cable Factor(dB) – Pre-Amplifier Factor(dB)
3. Margin value = Emission Level – Limit value
4. The other emission levels were very low against the limit.
5. " * " : Fundamental frequency, the limit was restricted at the RF Output Power.



RF Mode	TX 802.11n (HT20)	Channel	CH 140 : 5700 MHz
Frequency Range	1 GHz ~ 40 GHz	Detector Function & Bandwidth	(PK) RB = 1 MHz, VB = 3 MHz (AV) RB = 1 MHz, VB = 1 kHz
Input Power	120 Vac, 60 Hz	Environmental Conditions	25°C, 60% RH
Tested By	Charles Hsiao		

Antenna Polarity & Test Distance : Horizontal at 3 m								
No	Frequency (MHz)	Emission Level (dBuV/m)	Limit (dBuV/m)	Margin (dB)	Antenna Height (m)	Table Angle (Degree)	Raw Value (dBuV)	Correction Factor (dB/m)
1	*5700.00	100.31 PK			2.08 H	82	58.81	41.50
2	*5700.00	93.44 AV			2.08 H	82	51.94	41.50
3	#5725.00	60.33 PK	68.20	-7.87	2.08 H	82	50.23	10.10
4	11400.00	57.06 PK	74.00	-16.94	1.53 H	332	41.73	15.33
5	11400.00	47.54 AV	54.00	-6.46	1.53 H	332	32.21	15.33

Antenna Polarity & Test Distance : Vertical at 3 m								
No	Frequency (MHz)	Emission Level (dBuV/m)	Limit (dBuV/m)	Margin (dB)	Antenna Height (m)	Table Angle (Degree)	Raw Value (dBuV)	Correction Factor (dB/m)
1	*5700.00	98.18 PK			1.99 V	240	56.68	41.50
2	*5700.00	91.33 AV			1.99 V	240	49.83	41.50
3	#5725.00	60.00 PK	68.20	-8.20	1.99 V	240	49.90	10.10
4	11400.00	57.05 PK	74.00	-16.95	1.34 V	117	41.72	15.33
5	11400.00	47.50 AV	54.00	-6.50	1.34 V	117	32.17	15.33

Remarks:

1. Emission Level(dBuV/m) = Raw Value(dBuV) + Correction Factor(dB/m)
2. Correction Factor(dB/m) = Antenna Factor(dB/m) + Cable Factor(dB) – Pre-Amplifier Factor(dB)
3. Margin value = Emission Level – Limit value
4. The other emission levels were very low against the limit.
5. " * ": Fundamental frequency, the limit was restricted at the RF Output Power.
6. " # ": The radiated frequency is out of the restricted band.

RF Mode	TX 802.11n (HT20)	Channel	CH 144 : 5720 MHz
Frequency Range	1 GHz ~ 40 GHz	Detector Function & Bandwidth	(PK) RB = 1 MHz, VB = 3 MHz (AV) RB = 1 MHz, VB = 1 kHz
Input Power	120 Vac, 60 Hz	Environmental Conditions	25°C, 60% RH
Tested By	Karl Lee		

Antenna Polarity & Test Distance : Horizontal at 3 m								
No	Frequency (MHz)	Emission Level (dBuV/m)	Limit (dBuV/m)	Margin (dB)	Antenna Height (m)	Table Angle (Degree)	Raw Value (dBuV)	Correction Factor (dB/m)
1	5460.00	54.64 PK	74.00	-19.36	2.21 H	80	41.92	12.72
2	5460.00	47.06 AV	54.00	-6.94	2.21 H	80	34.34	12.72
3	#5470.00	58.88 PK	68.20	-9.32	2.21 H	80	46.15	12.73
4	*5720.00	106.33 PK			2.21 H	80	62.79	43.54
5	*5720.00	99.23 AV			2.21 H	80	55.69	43.54
6	11440.00	58.83 PK	74.00	-15.17	2.62 H	149	40.19	18.64
7	11440.00	49.16 AV	54.00	-4.84	2.62 H	149	30.52	18.64
Antenna Polarity & Test Distance : Vertical at 3 m								
No	Frequency (MHz)	Emission Level (dBuV/m)	Limit (dBuV/m)	Margin (dB)	Antenna Height (m)	Table Angle (Degree)	Raw Value (dBuV)	Correction Factor (dB/m)
1	5460.00	55.33 PK	74.00	-18.67	2.84 V	181	42.61	12.72
2	5460.00	47.21 AV	54.00	-6.79	2.84 V	181	34.49	12.72
3	#5470.00	58.02 PK	68.20	-10.18	2.84 V	181	45.29	12.73
4	*5720.00	101.07 PK			2.84 V	181	57.53	43.54
5	*5720.00	93.85 AV			2.84 V	181	50.31	43.54
6	11440.00	59.16 PK	74.00	-14.84	1.62 V	119	40.52	18.64
7	11440.00	49.45 AV	54.00	-4.55	1.62 V	119	30.81	18.64

Remarks:

1. Emission Level(dBuV/m) = Raw Value(dBuV) + Correction Factor(dB/m)
2. Correction Factor(dB/m) = Antenna Factor(dB/m) + Cable Factor(dB) – Pre-Amplifier Factor(dB)
3. Margin value = Emission Level – Limit value
4. The other emission levels were very low against the limit.
5. " * " : Fundamental frequency, the limit was restricted at the RF Output Power.
6. " # " : The radiated frequency is out of the restricted band.

RF Mode	TX 802.11n (HT40)	Channel	CH 102 : 5510 MHz
Frequency Range	1 GHz ~ 40 GHz	Detector Function & Bandwidth	(PK) RB = 1 MHz, VB = 3 MHz (AV) RB = 1 MHz, VB = 2 kHz
Input Power	120 Vac, 60 Hz	Environmental Conditions	25°C, 60% RH
Tested By	Charles Hsiao		

Antenna Polarity & Test Distance : Horizontal at 3 m								
No	Frequency (MHz)	Emission Level (dBuV/m)	Limit (dBuV/m)	Margin (dB)	Antenna Height (m)	Table Angle (Degree)	Raw Value (dBuV)	Correction Factor (dB/m)
1	5460.00	60.09 PK	74.00	-13.91	2.17 H	100	50.45	9.64
2	5460.00	50.50 AV	54.00	-3.50	2.17 H	100	40.86	9.64
3	#5470.00	61.39 PK	68.20	-6.81	2.17 H	100	51.83	9.56
4	*5510.00	97.15 PK			2.17 H	100	55.90	41.25
5	*5510.00	90.38 AV			2.17 H	100	49.13	41.25
6	#5725.00	60.53 PK	68.20	-7.67	2.17 H	100	50.43	10.10
7	11020.00	57.13 PK	74.00	-16.87	1.12 H	222	41.44	15.69
8	11020.00	47.66 AV	54.00	-6.34	1.12 H	222	31.97	15.69
Antenna Polarity & Test Distance : Vertical at 3 m								
No	Frequency (MHz)	Emission Level (dBuV/m)	Limit (dBuV/m)	Margin (dB)	Antenna Height (m)	Table Angle (Degree)	Raw Value (dBuV)	Correction Factor (dB/m)
1	5460.00	59.96 PK	74.00	-14.04	2.03 V	222	50.32	9.64
2	5460.00	50.14 AV	54.00	-3.86	2.03 V	222	40.50	9.64
3	#5470.00	60.40 PK	68.20	-7.80	2.03 V	222	50.84	9.56
4	*5510.00	94.51 PK			2.03 V	222	53.26	41.25
5	*5510.00	87.14 AV			2.03 V	222	45.89	41.25
6	#5725.00	60.08 PK	68.20	-8.12	2.03 V	222	49.98	10.10
7	11020.00	57.11 PK	74.00	-16.89	1.59 V	9	41.42	15.69
8	11020.00	47.60 AV	54.00	-6.40	1.59 V	9	31.91	15.69

Remarks:

1. Emission Level(dBuV/m) = Raw Value(dBuV) + Correction Factor(dB/m)
2. Correction Factor(dB/m) = Antenna Factor(dB/m) + Cable Factor(dB) – Pre-Amplifier Factor(dB)
3. Margin value = Emission Level – Limit value
4. The other emission levels were very low against the limit.
5. " * " : Fundamental frequency, the limit was restricted at the RF Output Power.
6. " # " : The radiated frequency is out of the restricted band.



RF Mode	TX 802.11n (HT40)	Channel	CH 110 : 5550 MHz
Frequency Range	1 GHz ~ 40 GHz	Detector Function & Bandwidth	(PK) RB = 1 MHz, VB = 3 MHz (AV) RB = 1 MHz, VB = 2 kHz
Input Power	120 Vac, 60 Hz	Environmental Conditions	25°C, 60% RH
Tested By	Charles Hsiao		

Antenna Polarity & Test Distance : Horizontal at 3 m								
No	Frequency (MHz)	Emission Level (dBuV/m)	Limit (dBuV/m)	Margin (dB)	Antenna Height (m)	Table Angle (Degree)	Raw Value (dBuV)	Correction Factor (dB/m)
1	*5550.00	100.45 PK			2.17 H	100	59.18	41.27
2	*5550.00	93.56 AV			2.17 H	100	52.29	41.27
3	11100.00	57.41 PK	74.00	-16.59	1.35 H	298	42.03	15.38
4	11100.00	47.58 AV	54.00	-6.42	1.35 H	298	32.20	15.38
Antenna Polarity & Test Distance : Vertical at 3 m								
No	Frequency (MHz)	Emission Level (dBuV/m)	Limit (dBuV/m)	Margin (dB)	Antenna Height (m)	Table Angle (Degree)	Raw Value (dBuV)	Correction Factor (dB/m)
1	*5550.00	98.56 PK			2.03 V	222	57.29	41.27
2	*5550.00	91.30 AV			2.03 V	222	50.03	41.27
3	11100.00	57.45 PK	74.00	-16.55	1.05 V	198	42.07	15.38
4	11100.00	47.65 AV	54.00	-6.35	1.05 V	198	32.27	15.38

Remarks:

1. Emission Level(dBuV/m) = Raw Value(dBuV) + Correction Factor(dB/m)
2. Correction Factor(dB/m) = Antenna Factor(dB/m) + Cable Factor(dB) – Pre-Amplifier Factor(dB)
3. Margin value = Emission Level – Limit value
4. The other emission levels were very low against the limit.
5. " * " : Fundamental frequency, the limit was restricted at the RF Output Power.

RF Mode	TX 802.11n (HT40)	Channel	CH 134 : 5670 MHz
Frequency Range	1 GHz ~ 40 GHz	Detector Function & Bandwidth	(PK) RB = 1 MHz, VB = 3 MHz (AV) RB = 1 MHz, VB = 2 kHz
Input Power	120 Vac, 60 Hz	Environmental Conditions	25°C, 60% RH
Tested By	Charles Hsiao		

Antenna Polarity & Test Distance : Horizontal at 3 m								
No	Frequency (MHz)	Emission Level (dBuV/m)	Limit (dBuV/m)	Margin (dB)	Antenna Height (m)	Table Angle (Degree)	Raw Value (dBuV)	Correction Factor (dB/m)
1	5460.00	60.08 PK	74.00	-13.92	2.17 H	100	50.44	9.64
2	5460.00	50.20 AV	54.00	-3.80	2.17 H	100	40.56	9.64
3	#5470.00	60.30 PK	68.20	-7.90	2.17 H	100	50.74	9.56
4	*5670.00	100.41 PK			2.17 H	100	59.01	41.40
5	*5670.00	93.58 AV			2.17 H	100	52.18	41.40
6	#5725.00	60.35 PK	68.20	-7.85	2.17 H	100	50.25	10.10
7	11340.00	57.41 PK	74.00	-16.59	1.00 H	211	41.71	15.70
8	11340.00	47.62 AV	54.00	-6.38	1.00 H	211	31.92	15.70
Antenna Polarity & Test Distance : Vertical at 3 m								
No	Frequency (MHz)	Emission Level (dBuV/m)	Limit (dBuV/m)	Margin (dB)	Antenna Height (m)	Table Angle (Degree)	Raw Value (dBuV)	Correction Factor (dB/m)
1	5460.00	59.94 PK	74.00	-14.06	2.03 V	222	50.30	9.64
2	5460.00	50.13 AV	54.00	-3.87	2.03 V	222	40.49	9.64
3	#5470.00	60.35 PK	68.20	-7.85	2.03 V	222	50.79	9.56
4	*5670.00	97.02 PK			2.03 V	222	55.62	41.40
5	*5670.00	90.14 AV			2.03 V	222	48.74	41.40
6	#5725.00	61.12 PK	68.20	-7.08	2.03 V	222	51.02	10.10
7	11340.00	57.44 PK	74.00	-16.56	1.32 V	298	41.74	15.70
8	11340.00	47.61 AV	54.00	-6.39	1.32 V	298	31.91	15.70

Remarks:

1. Emission Level(dBuV/m) = Raw Value(dBuV) + Correction Factor(dB/m)
2. Correction Factor(dB/m) = Antenna Factor(dB/m) + Cable Factor(dB) – Pre-Amplifier Factor(dB)
3. Margin value = Emission Level – Limit value
4. The other emission levels were very low against the limit.
5. " * " : Fundamental frequency, the limit was restricted at the RF Output Power.
6. " # " : The radiated frequency is out of the restricted band.

RF Mode	TX 802.11n (HT40)	Channel	CH 142 : 5710 MHz
Frequency Range	1 GHz ~ 40 GHz	Detector Function & Bandwidth	(PK) RB = 1 MHz, VB = 3 MHz (AV) RB = 1 MHz, VB = 2 kHz
Input Power	120 Vac, 60 Hz	Environmental Conditions	25°C, 60% RH
Tested By	Karl Lee		

Antenna Polarity & Test Distance : Horizontal at 3 m								
No	Frequency (MHz)	Emission Level (dBuV/m)	Limit (dBuV/m)	Margin (dB)	Antenna Height (m)	Table Angle (Degree)	Raw Value (dBuV)	Correction Factor (dB/m)
1	5460.00	54.20 PK	74.00	-19.80	2.21 H	80	41.48	12.72
2	5460.00	47.09 AV	54.00	-6.91	2.21 H	80	34.37	12.72
3	#5470.00	57.99 PK	68.20	-10.21	2.21 H	80	45.26	12.73
4	*5710.00	101.66 PK			2.21 H	80	58.17	43.49
5	*5710.00	95.92 AV			2.21 H	80	52.43	43.49
6	11420.00	58.44 PK	74.00	-15.56	1.83 H	226	39.82	18.62
7	11420.00	48.86 AV	54.00	-5.14	1.83 H	226	30.24	18.62
Antenna Polarity & Test Distance : Vertical at 3 m								
No	Frequency (MHz)	Emission Level (dBuV/m)	Limit (dBuV/m)	Margin (dB)	Antenna Height (m)	Table Angle (Degree)	Raw Value (dBuV)	Correction Factor (dB/m)
1	5460.00	54.65 PK	74.00	-19.35	2.84 V	181	41.93	12.72
2	5460.00	47.08 AV	54.00	-6.92	2.84 V	181	34.36	12.72
3	#5470.00	58.65 PK	68.20	-9.55	2.84 V	181	45.92	12.73
4	*5710.00	97.91 PK			2.84 V	181	54.42	43.49
5	*5710.00	91.46 AV			2.84 V	181	47.97	43.49
6	11420.00	58.22 PK	74.00	-15.78	1.09 V	27	39.60	18.62
7	11420.00	48.82 AV	54.00	-5.18	1.09 V	27	30.20	18.62

Remarks:

1. Emission Level(dBuV/m) = Raw Value(dBuV) + Correction Factor(dB/m)
2. Correction Factor(dB/m) = Antenna Factor(dB/m) + Cable Factor(dB) – Pre-Amplifier Factor(dB)
3. Margin value = Emission Level – Limit value
4. The other emission levels were very low against the limit.
5. " * ": Fundamental frequency, the limit was restricted at the RF Output Power.
6. " # ": The radiated frequency is out of the restricted band.



RF Mode	TX 802.11ac (VHT80)	Channel	CH 106 : 5530 MHz
Frequency Range	1 GHz ~ 40 GHz	Detector Function & Bandwidth	(PK) RB = 1 MHz, VB = 3 MHz (AV) RB = 1 MHz, VB = 4 kHz
Input Power	120 Vac, 60 Hz	Environmental Conditions	25°C, 60% RH
Tested By	Charles Hsiao		

Antenna Polarity & Test Distance : Horizontal at 3 m								
No	Frequency (MHz)	Emission Level (dBuV/m)	Limit (dBuV/m)	Margin (dB)	Antenna Height (m)	Table Angle (Degree)	Raw Value (dBuV)	Correction Factor (dB/m)
1	5460.00	60.21 PK	74.00	-13.79	2.17 H	100	50.57	9.64
2	5460.00	51.22 AV	54.00	-2.78	2.17 H	100	41.58	9.64
3	#5470.00	60.48 PK	68.20	-7.72	2.17 H	100	50.92	9.56
4	*5530.00	94.12 PK			2.17 H	100	52.86	41.26
5	*5530.00	87.45 AV			2.17 H	100	46.19	41.26
6	#5725.00	60.32 PK	68.20	-7.88	2.17 H	100	50.22	10.10
7	11060.00	57.36 PK	74.00	-16.64	1.00 H	100	41.83	15.53
8	11060.00	48.23 AV	54.00	-5.77	1.00 H	100	32.70	15.53
Antenna Polarity & Test Distance : Vertical at 3 m								
No	Frequency (MHz)	Emission Level (dBuV/m)	Limit (dBuV/m)	Margin (dB)	Antenna Height (m)	Table Angle (Degree)	Raw Value (dBuV)	Correction Factor (dB/m)
1	5460.00	60.07 PK	74.00	-13.93	2.14 V	221	50.43	9.64
2	5460.00	50.85 AV	54.00	-3.15	2.14 V	221	41.21	9.64
3	#5470.00	60.41 PK	68.20	-7.79	2.14 V	221	50.85	9.56
4	*5530.00	91.33 PK			2.14 V	221	50.07	41.26
5	*5530.00	84.48 AV			2.14 V	221	43.22	41.26
6	#5725.00	60.29 PK	68.20	-7.91	2.14 V	221	50.19	10.10
7	11060.00	57.38 PK	74.00	-16.62	1.05 V	248	41.85	15.53
8	11060.00	48.15 AV	54.00	-5.85	1.05 V	248	32.62	15.53

Remarks:

1. Emission Level(dBuV/m) = Raw Value(dBuV) + Correction Factor(dB/m)
2. Correction Factor(dB/m) = Antenna Factor(dB/m) + Cable Factor(dB) – Pre-Amplifier Factor(dB)
3. Margin value = Emission Level – Limit value
4. The other emission levels were very low against the limit.
5. " * ": Fundamental frequency, the limit was restricted at the RF Output Power.
6. " # ": The radiated frequency is out of the restricted band.



RF Mode	TX 802.11ac (VHT80)	Channel	CH 122 : 5610 MHz
Frequency Range	1 GHz ~ 40 GHz	Detector Function & Bandwidth	(PK) RB = 1 MHz, VB = 3 MHz (AV) RB = 1 MHz, VB = 4 kHz
Input Power	120 Vac, 60 Hz	Environmental Conditions	25°C, 60% RH
Tested By	Charles Hsiao		

Antenna Polarity & Test Distance : Horizontal at 3 m

No	Frequency (MHz)	Emission Level (dBuV/m)	Limit (dBuV/m)	Margin (dB)	Antenna Height (m)	Table Angle (Degree)	Raw Value (dBuV)	Correction Factor (dB/m)
1	5460.00	60.17 PK	74.00	-13.83	2.17 H	100	50.53	9.64
2	5460.00	51.00 AV	54.00	-3.00	2.17 H	100	41.36	9.64
3	#5470.00	60.48 PK	68.20	-7.72	2.17 H	100	50.92	9.56
4	*5610.00	94.25 PK			2.17 H	100	52.96	41.29
5	*5610.00	87.58 AV			2.17 H	100	46.29	41.29
6	#5725.00	60.29 PK	68.20	-7.91	2.17 H	100	50.19	10.10
7	11220.00	58.19 PK	74.00	-15.81	1.87 H	9	42.13	16.06
8	11220.00	48.30 AV	54.00	-5.70	1.87 H	9	32.24	16.06

Antenna Polarity & Test Distance : Vertical at 3 m

No	Frequency (MHz)	Emission Level (dBuV/m)	Limit (dBuV/m)	Margin (dB)	Antenna Height (m)	Table Angle (Degree)	Raw Value (dBuV)	Correction Factor (dB/m)
1	5460.00	60.04 PK	74.00	-13.96	2.14 V	221	50.40	9.64
2	5460.00	50.82 AV	54.00	-3.18	2.14 V	221	41.18	9.64
3	#5470.00	60.48 PK	68.20	-7.72	2.14 V	221	50.92	9.56
4	*5610.00	91.90 PK			2.14 V	221	50.61	41.29
5	*5610.00	84.74 AV			2.14 V	221	43.45	41.29
6	#5725.00	60.31 PK	68.20	-7.89	2.14 V	221	50.21	10.10
7	11220.00	57.86 PK	74.00	-16.14	1.05 V	164	41.80	16.06
8	11220.00	48.11 AV	54.00	-5.89	1.05 V	164	32.05	16.06

Remarks:

1. Emission Level(dBuV/m) = Raw Value(dBuV) + Correction Factor(dB/m)
2. Correction Factor(dB/m) = Antenna Factor(dB/m) + Cable Factor(dB) – Pre-Amplifier Factor(dB)
3. Margin value = Emission Level – Limit value
4. The other emission levels were very low against the limit.
5. " * ": Fundamental frequency, the limit was restricted at the RF Output Power.
6. " # ": The radiated frequency is out of the restricted band.

RF Mode	TX 802.11ac (VHT80)	Channel	CH 138 : 5690 MHz
Frequency Range	1 GHz ~ 40 GHz	Detector Function & Bandwidth	(PK) RB = 1 MHz, VB = 3 MHz (AV) RB = 1 MHz, VB = 4 kHz
Input Power	120 Vac, 60 Hz	Environmental Conditions	25°C, 60% RH
Tested By	Karl Lee		

Antenna Polarity & Test Distance : Horizontal at 3 m								
No	Frequency (MHz)	Emission Level (dBuV/m)	Limit (dBuV/m)	Margin (dB)	Antenna Height (m)	Table Angle (Degree)	Raw Value (dBuV)	Correction Factor (dB/m)
1	5460.00	54.82 PK	74.00	-19.18	2.10 H	83	42.10	12.72
2	5460.00	47.95 AV	54.00	-6.05	2.10 H	83	35.23	12.72
3	#5470.00	57.73 PK	68.20	-10.47	2.10 H	83	45.00	12.73
4	*5690.00	97.74 PK			2.21 H	80	54.30	43.44
5	*5690.00	92.37 AV			2.21 H	80	48.93	43.44
6	11380.00	57.92 PK	74.00	-16.08	1.51 H	182	39.40	18.52
7	11380.00	48.42 AV	54.00	-5.58	1.51 H	182	29.90	18.52
Antenna Polarity & Test Distance : Vertical at 3 m								
No	Frequency (MHz)	Emission Level (dBuV/m)	Limit (dBuV/m)	Margin (dB)	Antenna Height (m)	Table Angle (Degree)	Raw Value (dBuV)	Correction Factor (dB/m)
1	5460.00	54.94 PK	74.00	-19.06	1.07 V	181	42.22	12.72
2	5460.00	47.80 AV	54.00	-6.20	1.07 V	181	35.08	12.72
3	#5470.00	58.70 PK	68.20	-9.50	1.07 V	181	45.97	12.73
4	*5690.00	94.58 PK			1.07 V	181	51.14	43.44
5	*5690.00	88.57 AV			1.07 V	181	45.13	43.44
6	11380.00	58.22 PK	74.00	-15.78	2.42 V	164	39.70	18.52
7	11380.00	48.62 AV	54.00	-5.38	2.42 V	164	30.10	18.52

Remarks:

1. Emission Level(dBuV/m) = Raw Value(dBuV) + Correction Factor(dB/m)
2. Correction Factor(dB/m) = Antenna Factor(dB/m) + Cable Factor(dB) – Pre-Amplifier Factor(dB)
3. Margin value = Emission Level – Limit value
4. The other emission levels were very low against the limit.
5. " * ": Fundamental frequency, the limit was restricted at the RF Output Power.
6. " # ": The radiated frequency is out of the restricted band.



RF Mode	TX 802.11a	Channel	CH 149 : 5745 MHz
Frequency Range	1 GHz ~ 40 GHz	Detector Function & Bandwidth	(PK) RB = 1 MHz, VB = 3 MHz (AV) RB = 1 MHz, VB = 1 kHz
Input Power	120 Vac, 60 Hz	Environmental Conditions	25°C, 60% RH
Tested By	Charles Hsiao		

Antenna Polarity & Test Distance : Horizontal at 3 m

No	Frequency (MHz)	Emission Level (dBuV/m)	Limit (dBuV/m)	Margin (dB)	Antenna Height (m)	Table Angle (Degree)	Raw Value (dBuV)	Correction Factor (dB/m)
1	#5609.21	58.97 PK	68.20	-9.23	2.08 H	82	49.53	9.44
2	*5745.00	100.06 PK			2.08 H	82	58.47	41.59
3	*5745.00	93.37 AV			2.08 H	82	51.78	41.59
4	#5972.37	59.20 PK	68.20	-9.00	2.08 H	82	48.72	10.48
5	11490.00	57.42 PK	74.00	-16.58	1.15 H	54	41.51	15.91
6	11490.00	47.66 AV	54.00	-6.34	1.15 H	54	31.75	15.91

Antenna Polarity & Test Distance : Vertical at 3 m

No	Frequency (MHz)	Emission Level (dBuV/m)	Limit (dBuV/m)	Margin (dB)	Antenna Height (m)	Table Angle (Degree)	Raw Value (dBuV)	Correction Factor (dB/m)
1	#5644.44	58.14 PK	68.20	-10.06	1.99 V	220	48.43	9.71
2	*5745.00	98.05 PK			1.99 V	220	56.46	41.59
3	*5745.00	91.37 AV			1.99 V	220	49.78	41.59
4	#5945.15	59.40 PK	68.20	-8.80	1.99 V	220	49.21	10.19
5	11490.00	57.29 PK	74.00	-16.71	1.13 V	32	41.38	15.91
6	11490.00	47.41 AV	54.00	-6.59	1.13 V	32	31.50	15.91

Remarks:

1. Emission Level(dBuV/m) = Raw Value(dBuV) + Correction Factor(dB/m)
2. Correction Factor(dB/m) = Antenna Factor(dB/m) + Cable Factor(dB) – Pre-Amplifier Factor(dB)
3. Margin value = Emission Level – Limit value
4. The other emission levels were very low against the limit.
5. " * ": Fundamental frequency, the limit was restricted at the RF Output Power.



RF Mode	TX 802.11a	Channel	CH 157 : 5785 MHz
Frequency Range	1 GHz ~ 40 GHz	Detector Function & Bandwidth	(PK) RB = 1 MHz, VB = 3 MHz (AV) RB = 1 MHz, VB = 1 kHz
Input Power	120 Vac, 60 Hz	Environmental Conditions	25°C, 60% RH
Tested By	Charles Hsiao		

Antenna Polarity & Test Distance : Horizontal at 3 m								
No	Frequency (MHz)	Emission Level (dBuV/m)	Limit (dBuV/m)	Margin (dB)	Antenna Height (m)	Table Angle (Degree)	Raw Value (dBuV)	Correction Factor (dB/m)
1	#5646.85	57.89 PK	68.20	-10.31	2.08 H	82	48.17	9.72
2	*5785.00	103.31 PK			2.08 H	82	61.66	41.65
3	*5785.00	96.63 AV			2.08 H	82	54.98	41.65
4	#5969.17	58.68 PK	68.20	-9.52	2.08 H	82	48.25	10.43
5	11570.00	57.36 PK	74.00	-16.64	1.55 H	21	41.77	15.59
6	11570.00	47.55 AV	54.00	-6.45	1.55 H	21	31.96	15.59
Antenna Polarity & Test Distance : Vertical at 3 m								
No	Frequency (MHz)	Emission Level (dBuV/m)	Limit (dBuV/m)	Margin (dB)	Antenna Height (m)	Table Angle (Degree)	Raw Value (dBuV)	Correction Factor (dB/m)
1	#5634.03	58.12 PK	68.20	-10.08	1.99 V	220	48.50	9.62
2	*5785.00	100.04 PK			1.99 V	220	58.39	41.65
3	*5785.00	93.45 AV			1.99 V	220	51.80	41.65
4	#5944.34	58.51 PK	68.20	-9.69	1.99 V	220	48.33	10.18
5	11570.00	57.42 PK	74.00	-16.58	1.02 V	211	41.83	15.59
6	11570.00	47.60 AV	54.00	-6.40	1.02 V	211	32.01	15.59

Remarks:

1. Emission Level(dBuV/m) = Raw Value(dBuV) + Correction Factor(dB/m)
2. Correction Factor(dB/m) = Antenna Factor(dB/m) + Cable Factor(dB) – Pre-Amplifier Factor(dB)
3. Margin value = Emission Level – Limit value
4. The other emission levels were very low against the limit.
5. " * ": Fundamental frequency, the limit was restricted at the RF Output Power.
6. " # ": The radiated frequency is out of the restricted band.



RF Mode	TX 802.11a	Channel	CH 165 : 5825 MHz
Frequency Range	1 GHz ~ 40 GHz	Detector Function & Bandwidth	(PK) RB = 1 MHz, VB = 3 MHz (AV) RB = 1 MHz, VB = 1 kHz
Input Power	120 Vac, 60 Hz	Environmental Conditions	25°C, 60% RH
Tested By	Charles Hsiao		

Antenna Polarity & Test Distance : Horizontal at 3 m

No	Frequency (MHz)	Emission Level (dBuV/m)	Limit (dBuV/m)	Margin (dB)	Antenna Height (m)	Table Angle (Degree)	Raw Value (dBuV)	Correction Factor (dB/m)
1	#5646.45	58.29 PK	68.20	-9.91	2.08 H	82	48.57	9.72
2	*5825.00	100.61 PK			2.08 H	82	58.91	41.70
3	*5825.00	93.45 AV			2.08 H	82	51.75	41.70
4	#5957.96	59.18 PK	68.20	-9.02	2.08 H	82	48.85	10.33
5	11650.00	57.41 PK	74.00	-16.59	1.64 H	49	41.51	15.90
6	11650.00	47.53 AV	54.00	-6.47	1.64 H	49	31.63	15.90

Antenna Polarity & Test Distance : Vertical at 3 m

No	Frequency (MHz)	Emission Level (dBuV/m)	Limit (dBuV/m)	Margin (dB)	Antenna Height (m)	Table Angle (Degree)	Raw Value (dBuV)	Correction Factor (dB/m)
1	#5629.63	57.59 PK	68.20	-10.61	1.99 V	240	48.00	9.59
2	*5825.00	97.06 PK			1.99 V	240	55.36	41.70
3	*5825.00	90.78 AV			1.99 V	240	49.08	41.70
4	#5978.78	58.01 PK	68.20	-10.19	1.99 V	240	47.48	10.53
5	11650.00	57.33 PK	74.00	-16.67	1.20 V	31	41.43	15.90
6	11650.00	47.49 AV	54.00	-6.51	1.20 V	31	31.59	15.90

Remarks:

1. Emission Level(dBuV/m) = Raw Value(dBuV) + Correction Factor(dB/m)
2. Correction Factor(dB/m) = Antenna Factor(dB/m) + Cable Factor(dB) – Pre-Amplifier Factor(dB)
3. Margin value = Emission Level – Limit value
4. The other emission levels were very low against the limit.
5. " * ": Fundamental frequency, the limit was restricted at the RF Output Power.
6. " # ": The radiated frequency is out of the restricted band.



RF Mode	TX 802.11n (HT20)	Channel	CH 149 : 5745 MHz
Frequency Range	1 GHz ~ 40 GHz	Detector Function & Bandwidth	(PK) RB = 1 MHz, VB = 3 MHz (AV) RB = 1 MHz, VB = 1 kHz
Input Power	120 Vac, 60 Hz	Environmental Conditions	25°C, 60% RH
Tested By	Charles Hsiao		

Antenna Polarity & Test Distance : Horizontal at 3 m								
No	Frequency (MHz)	Emission Level (dBuV/m)	Limit (dBuV/m)	Margin (dB)	Antenna Height (m)	Table Angle (Degree)	Raw Value (dBuV)	Correction Factor (dB/m)
1	#5647.25	59.23 PK	68.20	-8.97	2.08 H	82	49.50	9.73
2	*5745.00	101.16 PK			2.08 H	82	59.57	41.59
3	*5745.00	94.33 AV			2.08 H	82	52.74	41.59
4	#5971.57	59.55 PK	68.20	-8.65	2.08 H	82	49.09	10.46
5	11490.00	57.40 PK	74.00	-16.60	1.65 H	337	41.49	15.91
6	11490.00	47.53 AV	54.00	-6.47	1.65 H	337	31.62	15.91
Antenna Polarity & Test Distance : Vertical at 3 m								
No	Frequency (MHz)	Emission Level (dBuV/m)	Limit (dBuV/m)	Margin (dB)	Antenna Height (m)	Table Angle (Degree)	Raw Value (dBuV)	Correction Factor (dB/m)
1	#5606.01	57.87 PK	68.20	-10.33	1.99 V	240	48.46	9.41
2	*5745.00	98.01 PK			1.99 V	240	56.42	41.59
3	*5745.00	91.19 AV			1.99 V	240	49.60	41.59
4	#5952.75	59.14 PK	68.20	-9.06	1.99 V	240	48.86	10.28
5	11490.00	57.28 PK	74.00	-16.72	1.34 V	44	41.37	15.91
6	11490.00	47.45 AV	54.00	-6.55	1.34 V	44	31.54	15.91

Remarks:

1. Emission Level(dBuV/m) = Raw Value(dBuV) + Correction Factor(dB/m)
2. Correction Factor(dB/m) = Antenna Factor(dB/m) + Cable Factor(dB) – Pre-Amplifier Factor(dB)
3. Margin value = Emission Level – Limit value
4. The other emission levels were very low against the limit.
5. " * ": Fundamental frequency, the limit was restricted at the RF Output Power.
6. " # ": The radiated frequency is out of the restricted band.



RF Mode	TX 802.11n (HT20)	Channel	CH 157 : 5785 MHz
Frequency Range	1 GHz ~ 40 GHz	Detector Function & Bandwidth	(PK) RB = 1 MHz, VB = 3 MHz (AV) RB = 1 MHz, VB = 1 kHz
Input Power	120 Vac, 60 Hz	Environmental Conditions	25°C, 60% RH
Tested By	Charles Hsiao		

Antenna Polarity & Test Distance : Horizontal at 3 m								
No	Frequency (MHz)	Emission Level (dBuV/m)	Limit (dBuV/m)	Margin (dB)	Antenna Height (m)	Table Angle (Degree)	Raw Value (dBuV)	Correction Factor (dB/m)
1	#5630.83	58.84 PK	68.20	-9.36	2.08 H	82	49.24	9.60
2	*5785.00	103.37 PK			2.08 H	82	61.72	41.65
3	*5785.00	96.45 AV			2.08 H	82	54.80	41.65
4	#6000.00	59.04 PK	68.20	-9.16	2.08 H	82	48.29	10.75
5	11570.00	57.42 PK	74.00	-16.58	1.15 H	241	41.83	15.59
6	11570.00	47.55 AV	54.00	-6.45	1.15 H	241	31.96	15.59

Antenna Polarity & Test Distance : Vertical at 3 m								
No	Frequency (MHz)	Emission Level (dBuV/m)	Limit (dBuV/m)	Margin (dB)	Antenna Height (m)	Table Angle (Degree)	Raw Value (dBuV)	Correction Factor (dB/m)
1	#5602.80	58.94 PK	68.20	-9.26	1.99 V	240	49.55	9.39
2	*5785.00	100.25 PK			1.99 V	240	58.60	41.65
3	*5785.00	93.77 AV			1.99 V	240	52.12	41.65
4	#5989.99	59.36 PK	68.20	-8.84	1.99 V	240	48.71	10.65
5	11570.00	57.49 PK	74.00	-16.51	1.05 V	285	41.90	15.59
6	11570.00	47.65 AV	54.00	-6.35	1.05 V	285	32.06	15.59

Remarks:

1. Emission Level(dBuV/m) = Raw Value(dBuV) + Correction Factor(dB/m)
2. Correction Factor(dB/m) = Antenna Factor(dB/m) + Cable Factor(dB) – Pre-Amplifier Factor(dB)
3. Margin value = Emission Level – Limit value
4. The other emission levels were very low against the limit.
5. " * ": Fundamental frequency, the limit was restricted at the RF Output Power.
6. " # ": The radiated frequency is out of the restricted band.



RF Mode	TX 802.11n (HT20)	Channel	CH 165 : 5825 MHz
Frequency Range	1 GHz ~ 40 GHz	Detector Function & Bandwidth	(PK) RB = 1 MHz, VB = 3 MHz (AV) RB = 1 MHz, VB = 1 kHz
Input Power	120 Vac, 60 Hz	Environmental Conditions	25°C, 60% RH
Tested By	Charles Hsiao		

Antenna Polarity & Test Distance : Horizontal at 3 m								
No	Frequency (MHz)	Emission Level (dBuV/m)	Limit (dBuV/m)	Margin (dB)	Antenna Height (m)	Table Angle (Degree)	Raw Value (dBuV)	Correction Factor (dB/m)
1	#5621.22	58.58 PK	68.20	-9.62	2.08 H	82	49.05	9.53
2	*5825.00	98.05 PK			2.08 H	82	56.35	41.70
3	*5825.00	91.45 AV			2.08 H	82	49.75	41.70
4	#5967.17	59.44 PK	68.20	-8.76	2.08 H	82	49.02	10.42
5	11650.00	57.68 PK	74.00	-16.32	1.15 H	54	41.78	15.90
6	11650.00	47.70 AV	54.00	-6.30	1.15 H	54	31.80	15.90
Antenna Polarity & Test Distance : Vertical at 3 m								
No	Frequency (MHz)	Emission Level (dBuV/m)	Limit (dBuV/m)	Margin (dB)	Antenna Height (m)	Table Angle (Degree)	Raw Value (dBuV)	Correction Factor (dB/m)
1	#5636.84	58.94 PK	68.20	-9.26	1.99 V	240	49.30	9.64
2	*5825.00	97.08 PK			1.99 V	240	55.38	41.70
3	*5825.00	90.63 AV			1.99 V	240	48.93	41.70
4	#5962.36	59.05 PK	68.20	-9.15	1.99 V	240	48.67	10.38
5	11650.00	57.43 PK	74.00	-16.57	1.98 V	339	41.53	15.90
6	11650.00	47.58 AV	54.00	-6.42	1.98 V	339	31.68	15.90

Remarks:

1. Emission Level(dBuV/m) = Raw Value(dBuV) + Correction Factor(dB/m)
2. Correction Factor(dB/m) = Antenna Factor(dB/m) + Cable Factor(dB) – Pre-Amplifier Factor(dB)
3. Margin value = Emission Level – Limit value
4. The other emission levels were very low against the limit.
5. " * ": Fundamental frequency, the limit was restricted at the RF Output Power.
6. " # ": The radiated frequency is out of the restricted band.



RF Mode	TX 802.11n (HT40)	Channel	CH 151 : 5755 MHz
Frequency Range	1 GHz ~ 40 GHz	Detector Function & Bandwidth	(PK) RB = 1 MHz, VB = 3 MHz (AV) RB = 1 MHz, VB = 2 kHz
Input Power	120 Vac, 60 Hz	Environmental Conditions	25°C, 60% RH
Tested By	Charles Hsiao		

Antenna Polarity & Test Distance : Horizontal at 3 m								
No	Frequency (MHz)	Emission Level (dBuV/m)	Limit (dBuV/m)	Margin (dB)	Antenna Height (m)	Table Angle (Degree)	Raw Value (dBuV)	Correction Factor (dB/m)
1	#5637.64	58.58 PK	68.20	-9.62	2.08 H	82	48.93	9.65
2	*5755.00	97.00 PK			2.08 H	82	55.39	41.61
3	*5755.00	90.45 AV			2.08 H	82	48.84	41.61
4	#5990.39	59.20 PK	68.20	-9.00	2.08 H	82	48.55	10.65
5	11510.00	57.85 PK	74.00	-16.15	1.15 H	241	41.93	15.92
6	11510.00	47.78 AV	54.00	-6.22	1.15 H	241	31.86	15.92
Antenna Polarity & Test Distance : Vertical at 3 m								
No	Frequency (MHz)	Emission Level (dBuV/m)	Limit (dBuV/m)	Margin (dB)	Antenna Height (m)	Table Angle (Degree)	Raw Value (dBuV)	Correction Factor (dB/m)
1	#5612.81	58.23 PK	68.20	-9.97	1.99 V	240	48.76	9.47
2	*5755.00	94.06 PK			1.99 V	240	52.45	41.61
3	*5755.00	87.49 AV			1.99 V	240	45.88	41.61
4	#5990.39	59.10 PK	68.20	-9.10	1.99 V	240	48.45	10.65
5	11510.00	57.60 PK	74.00	-16.40	1.34 V	106	41.68	15.92
6	11510.00	47.79 AV	54.00	-6.21	1.34 V	106	31.87	15.92

Remarks:

1. Emission Level(dBuV/m) = Raw Value(dBuV) + Correction Factor(dB/m)
2. Correction Factor(dB/m) = Antenna Factor(dB/m) + Cable Factor(dB) – Pre-Amplifier Factor(dB)
3. Margin value = Emission Level – Limit value
4. The other emission levels were very low against the limit.
5. " * ": Fundamental frequency, the limit was restricted at the RF Output Power.
6. " # ": The radiated frequency is out of the restricted band.



RF Mode	TX 802.11n (HT40)	Channel	CH 159 : 5795 MHz
Frequency Range	1 GHz ~ 40 GHz	Detector Function & Bandwidth	(PK) RB = 1 MHz, VB = 3 MHz (AV) RB = 1 MHz, VB = 2 kHz
Input Power	120 Vac, 60 Hz	Environmental Conditions	25°C, 60% RH
Tested By	Charles Hsiao		

Antenna Polarity & Test Distance : Horizontal at 3 m								
No	Frequency (MHz)	Emission Level (dBuV/m)	Limit (dBuV/m)	Margin (dB)	Antenna Height (m)	Table Angle (Degree)	Raw Value (dBuV)	Correction Factor (dB/m)
1	#5637.24	58.59 PK	68.20	-9.61	2.08 H	82	48.95	9.64
2	*5795.00	97.30 PK			2.08 H	82	55.64	41.66
3	*5795.00	90.17 AV			2.08 H	82	48.51	41.66
4	#5969.17	59.53 PK	68.20	-8.67	2.08 H	82	49.10	10.43
5	11590.00	57.50 PK	74.00	-16.50	1.45 H	228	42.02	15.48
6	11590.00	47.74 AV	54.00	-6.26	1.45 H	228	32.26	15.48
Antenna Polarity & Test Distance : Vertical at 3 m								
No	Frequency (MHz)	Emission Level (dBuV/m)	Limit (dBuV/m)	Margin (dB)	Antenna Height (m)	Table Angle (Degree)	Raw Value (dBuV)	Correction Factor (dB/m)
1	#5601.60	57.57 PK	68.20	-10.63	1.99 V	240	48.19	9.38
2	*5795.00	94.14 PK			1.99 V	240	52.48	41.66
3	*5795.00	87.29 AV			1.99 V	240	45.63	41.66
4	#5990.79	58.78 PK	68.20	-9.42	1.99 V	240	48.12	10.66
5	11590.00	57.61 PK	74.00	-16.39	1.15 V	241	42.13	15.48
6	11590.00	47.88 AV	54.00	-6.12	1.15 V	241	32.40	15.48

Remarks:

1. Emission Level(dBuV/m) = Raw Value(dBuV) + Correction Factor(dB/m)
2. Correction Factor(dB/m) = Antenna Factor(dB/m) + Cable Factor(dB) – Pre-Amplifier Factor(dB)
3. Margin value = Emission Level – Limit value
4. The other emission levels were very low against the limit.
5. " * " : Fundamental frequency, the limit was restricted at the RF Output Power.
6. " # " : The radiated frequency is out of the restricted band.



RF Mode	TX 802.11ac (VHT80)	Channel	CH 155 : 5775 MHz
Frequency Range	1 GHz ~ 40 GHz	Detector Function & Bandwidth	(PK) RB = 1 MHz, VB = 3 MHz (AV) RB = 1 MHz, VB = 4 kHz
Input Power	120 Vac, 60 Hz	Environmental Conditions	25°C, 60% RH
Tested By	Charles Hsiao		

Antenna Polarity & Test Distance : Horizontal at 3 m								
No	Frequency (MHz)	Emission Level (dBuV/m)	Limit (dBuV/m)	Margin (dB)	Antenna Height (m)	Table Angle (Degree)	Raw Value (dBuV)	Correction Factor (dB/m)
1	#5642.84	59.27 PK	68.20	-8.93	2.07 H	80	49.57	9.70
2	*5775.00	93.32 PK			2.07 H	80	51.69	41.63
3	*5775.00	86.58 AV			2.07 H	80	44.95	41.63
4	#5996.40	59.73 PK	68.20	-8.47	2.07 H	80	49.02	10.71
5	11550.00	58.02 PK	74.00	-15.98	1.15 H	54	42.32	15.70
6	11550.00	48.26 AV	54.00	-5.74	1.15 H	54	32.56	15.70
Antenna Polarity & Test Distance : Vertical at 3 m								
No	Frequency (MHz)	Emission Level (dBuV/m)	Limit (dBuV/m)	Margin (dB)	Antenna Height (m)	Table Angle (Degree)	Raw Value (dBuV)	Correction Factor (dB/m)
1	#5644.04	58.97 PK	68.20	-9.23	1.99 V	240	49.26	9.71
2	*5775.00	89.54 PK			1.99 V	240	47.91	41.63
3	*5775.00	82.77 AV			1.99 V	240	41.14	41.63
4	#5990.79	59.05 PK	68.20	-9.15	1.99 V	240	48.39	10.66
5	11550.00	58.04 PK	74.00	-15.96	1.15 V	354	42.34	15.70
6	11550.00	48.21 AV	54.00	-5.79	1.15 V	354	32.51	15.70

Remarks:

1. Emission Level(dBuV/m) = Raw Value(dBuV) + Correction Factor(dB/m)
2. Correction Factor(dB/m) = Antenna Factor(dB/m) + Cable Factor(dB) – Pre-Amplifier Factor(dB)
3. Margin value = Emission Level – Limit value
4. The other emission levels were very low against the limit.
5. " * " : Fundamental frequency, the limit was restricted at the RF Output Power.
6. " # " : The radiated frequency is out of the restricted band.

7.10 Band Edge Measurement

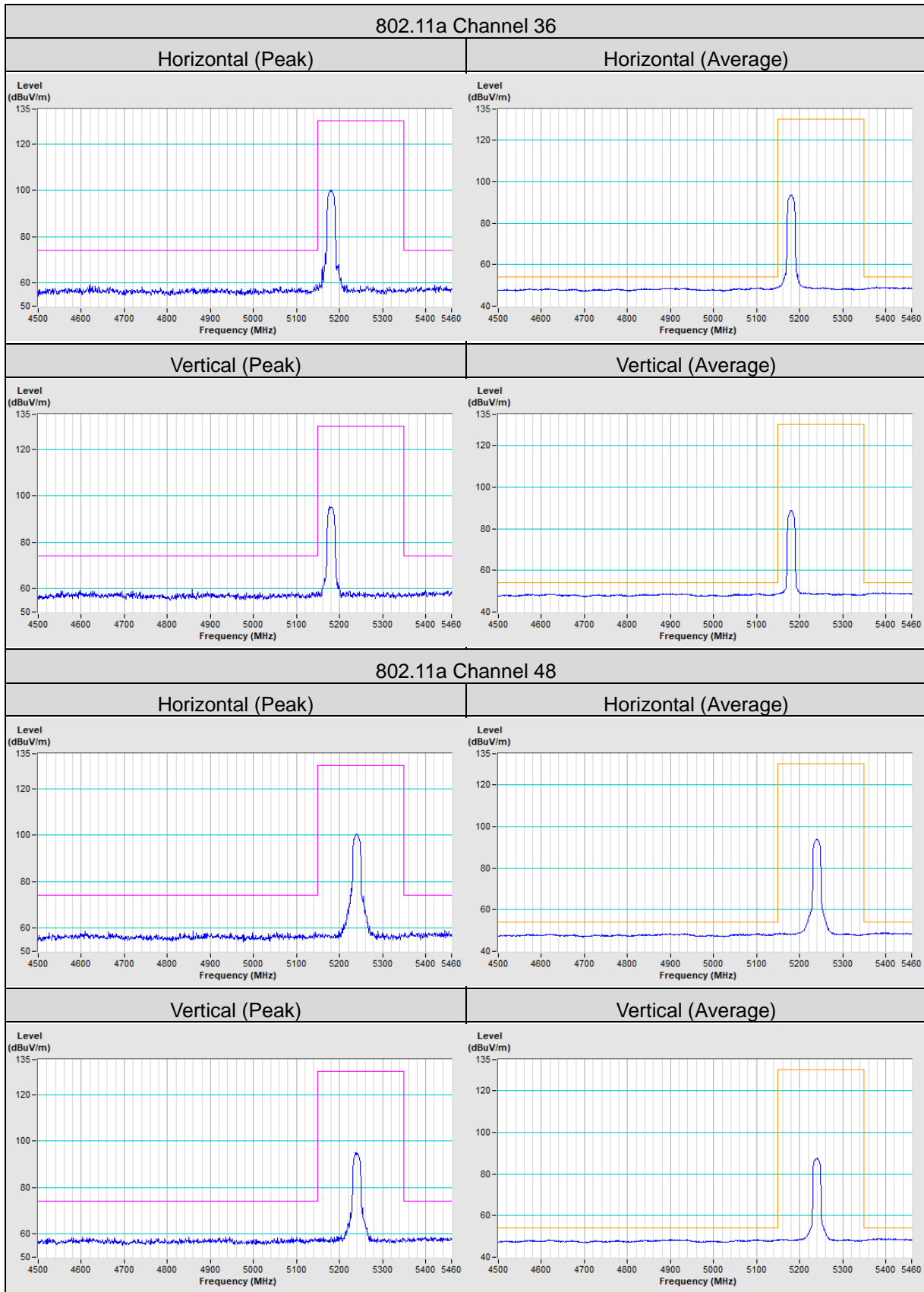

802.11n (HT20) Channel 36

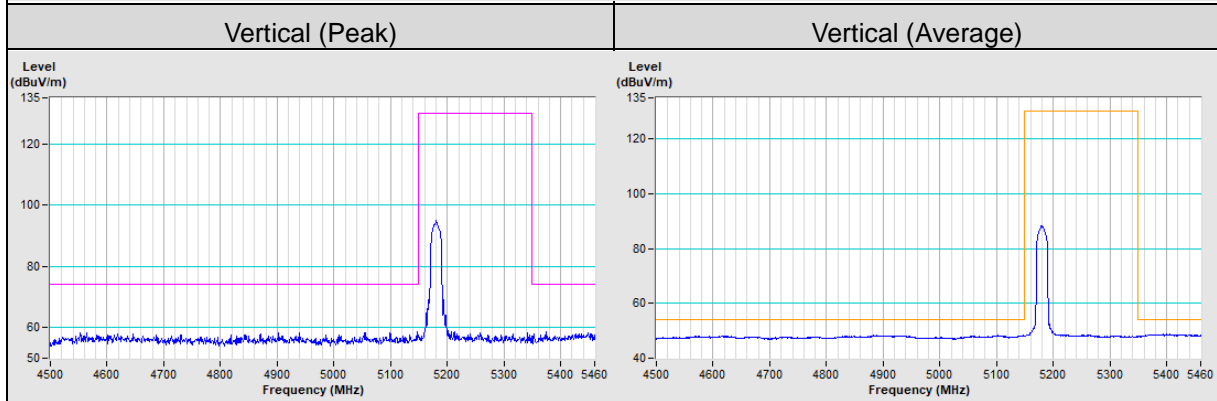
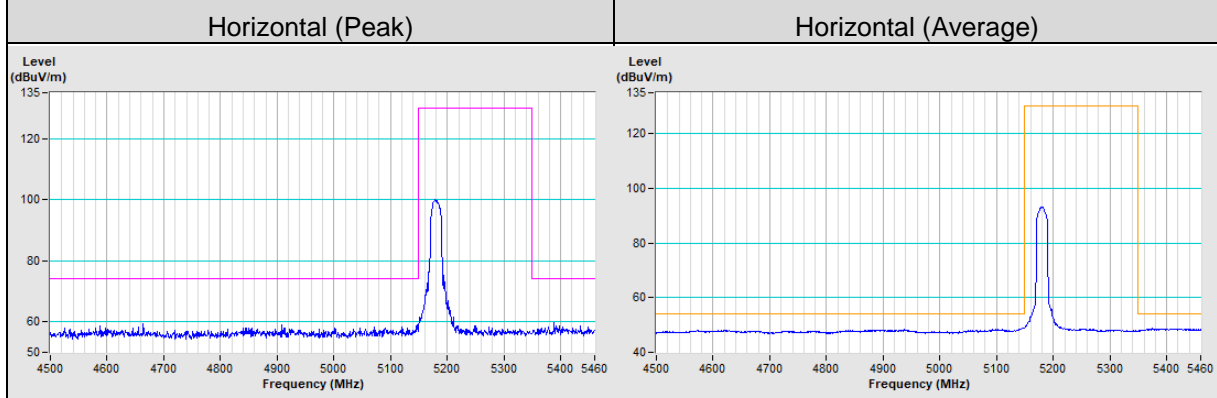

802.11n (HT20) Channel 48

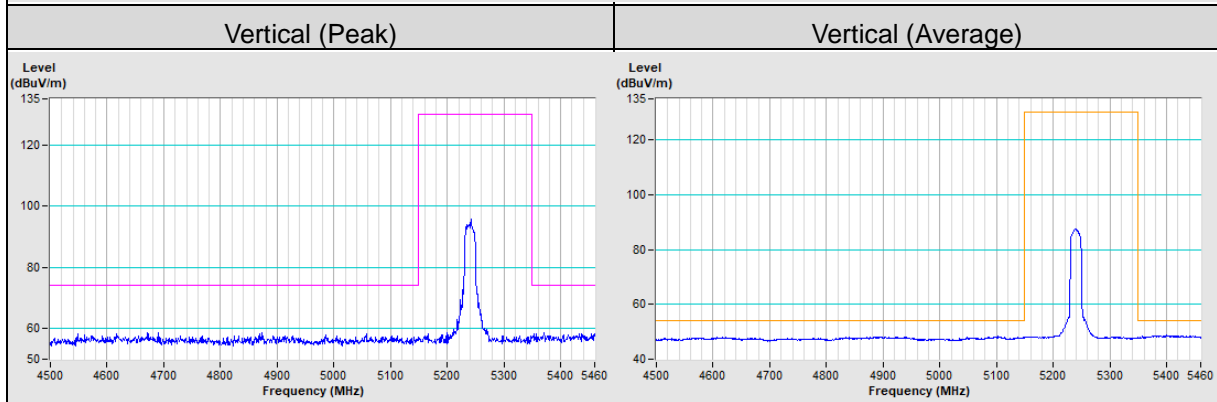
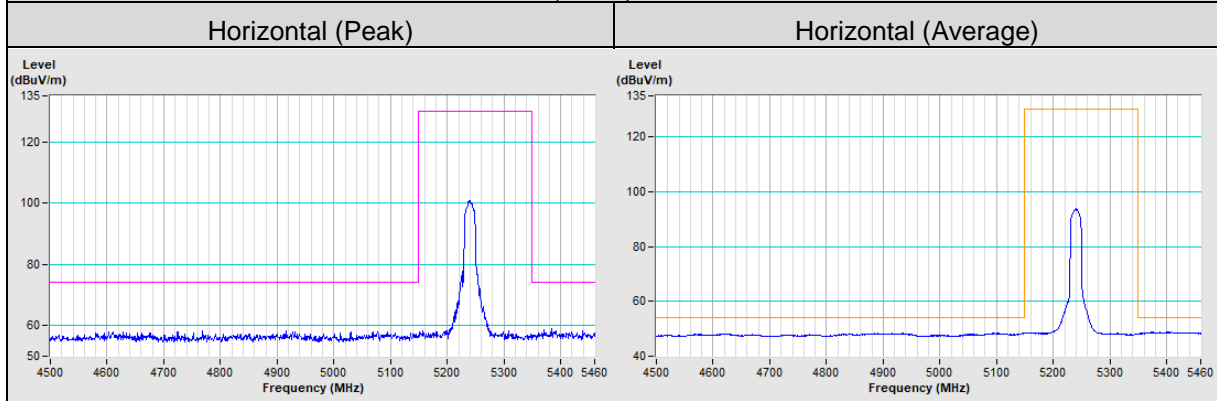

802.11n (HT40) Channel 38

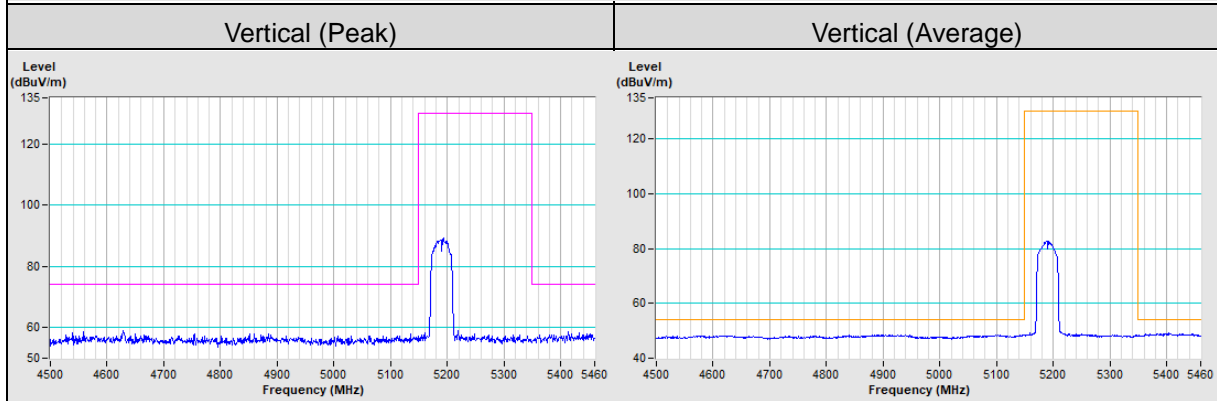
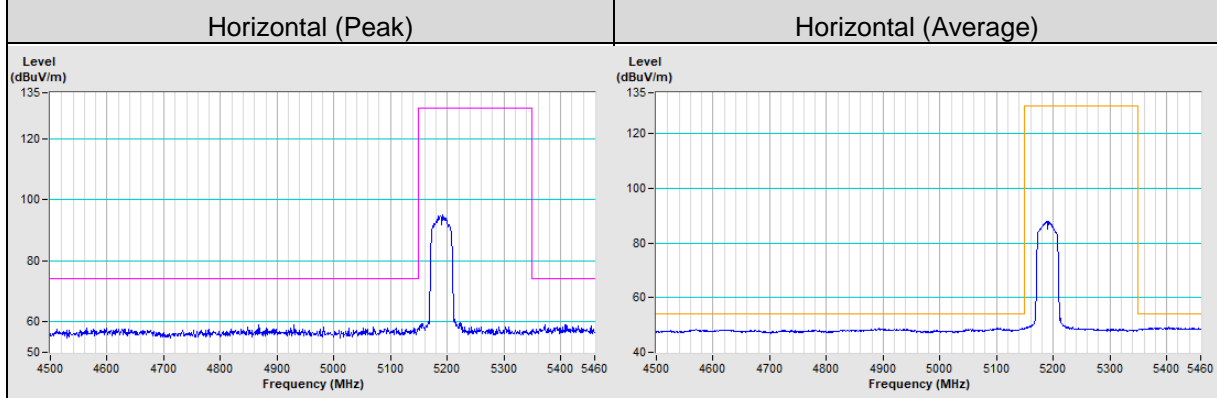

802.11n (HT40) Channel 46

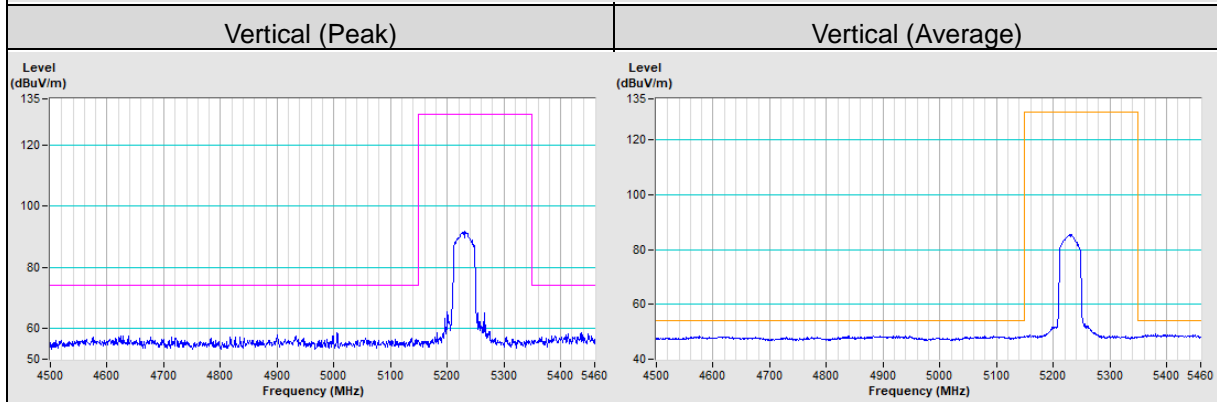
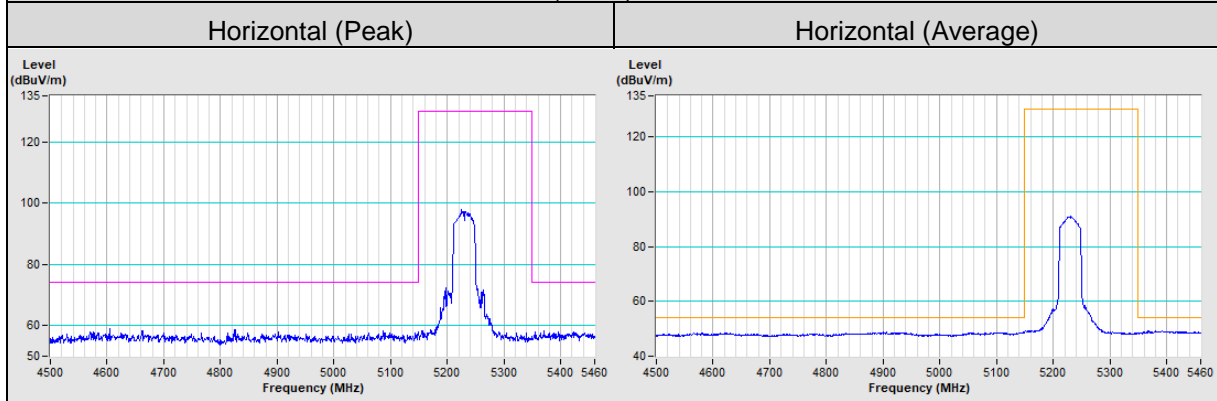

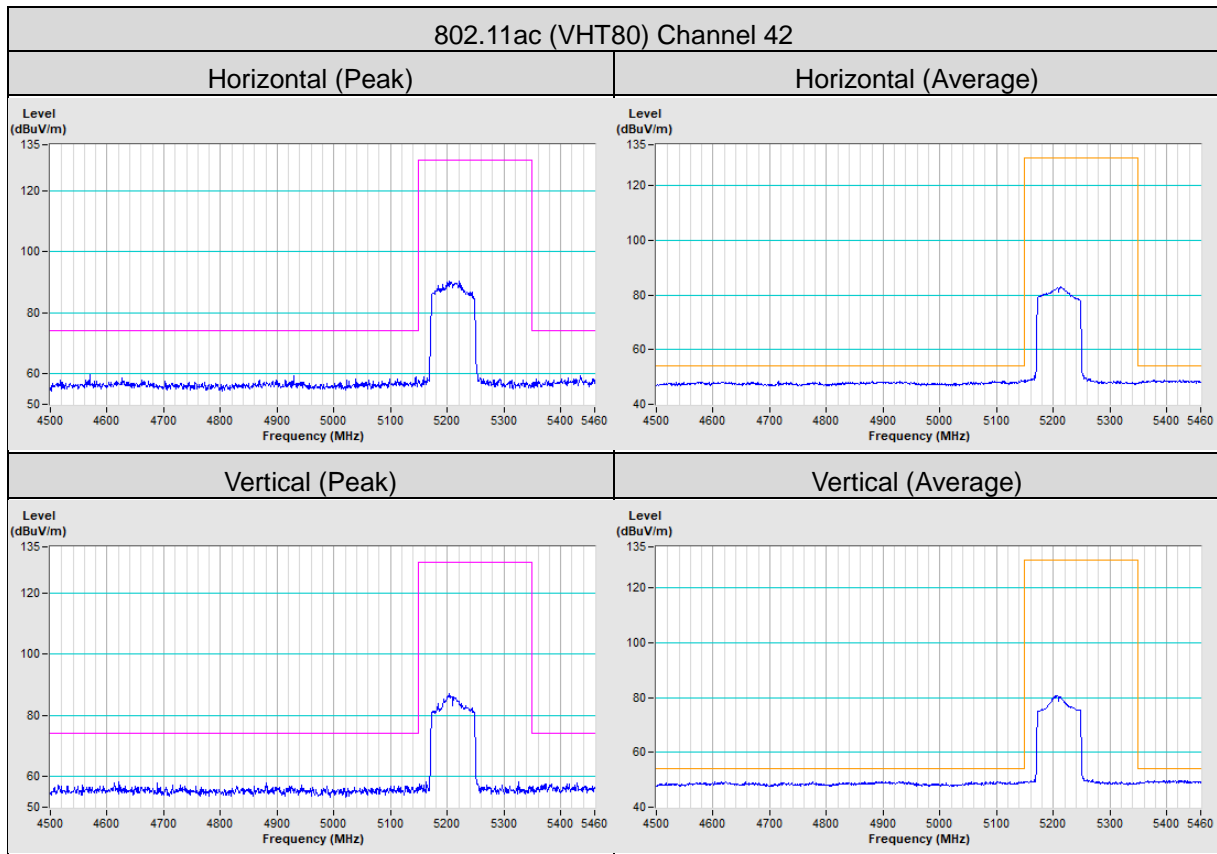

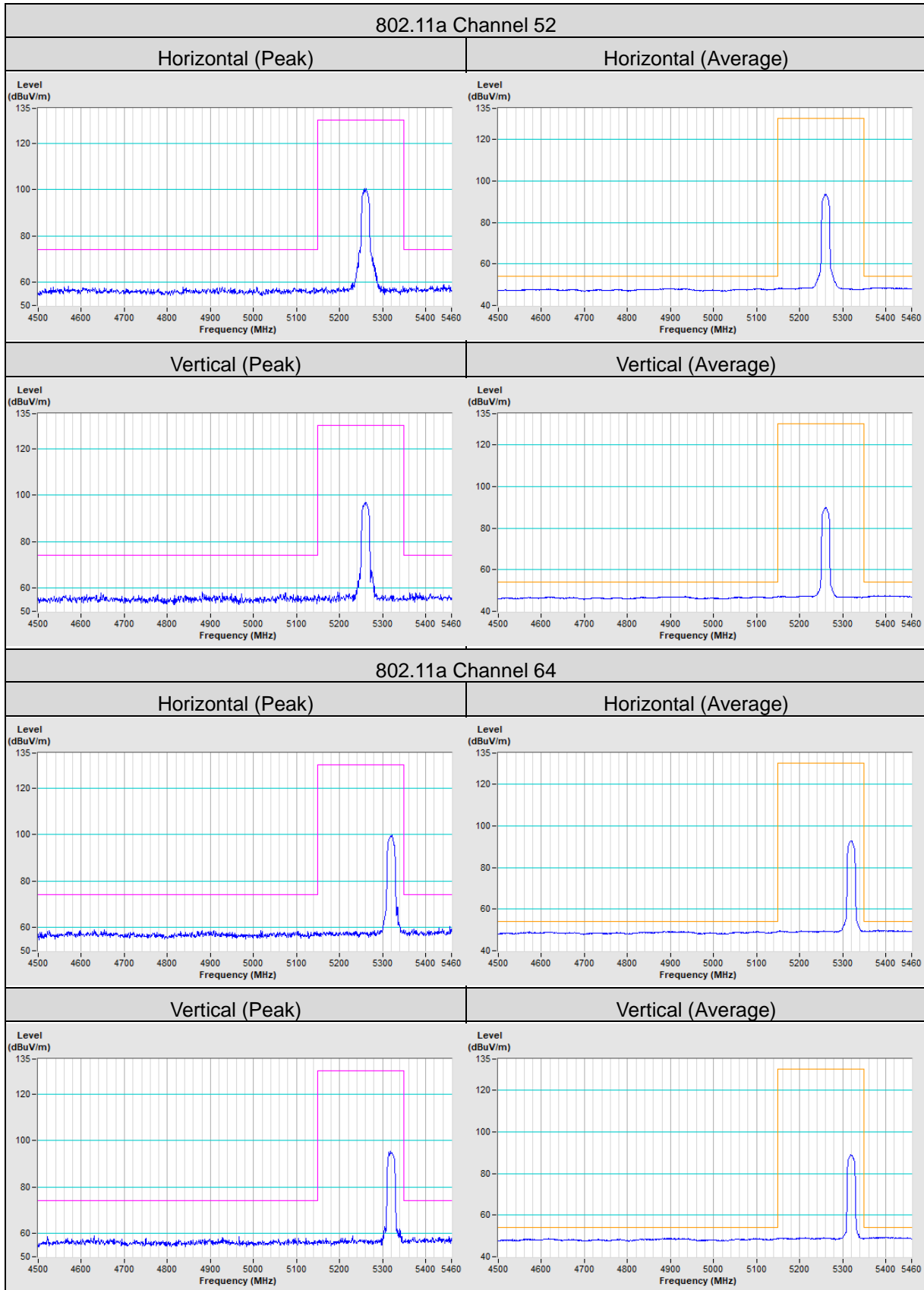

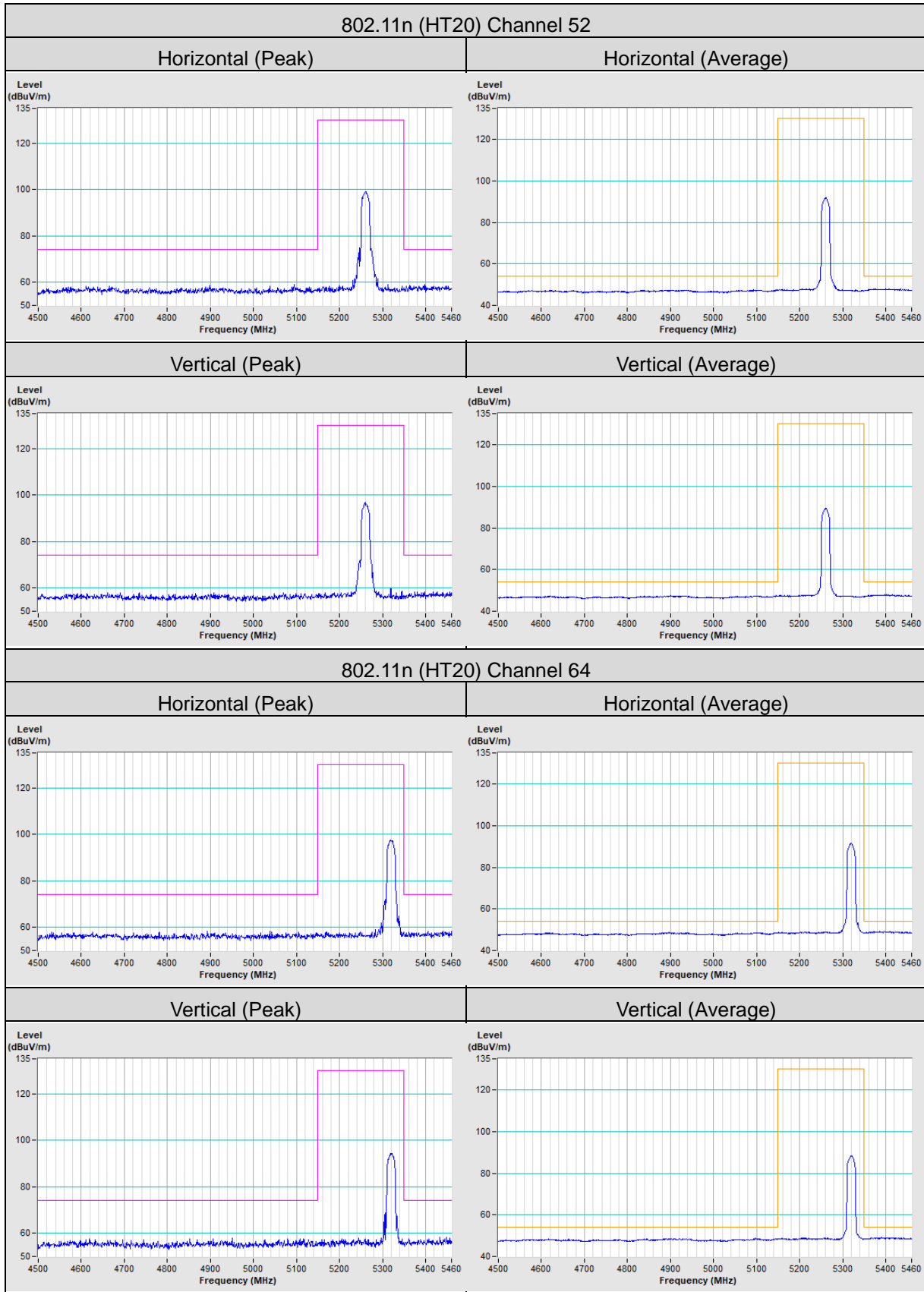

802.11n (HT40) Channel 54

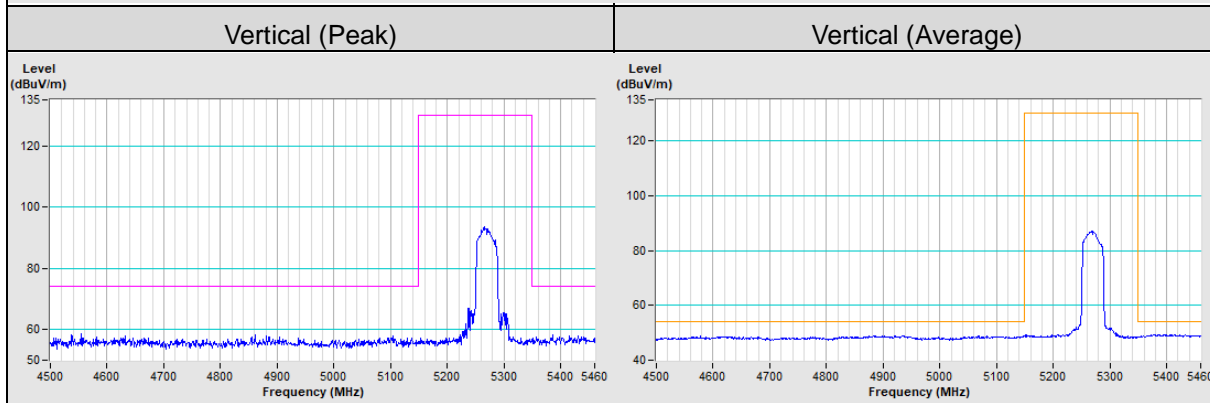
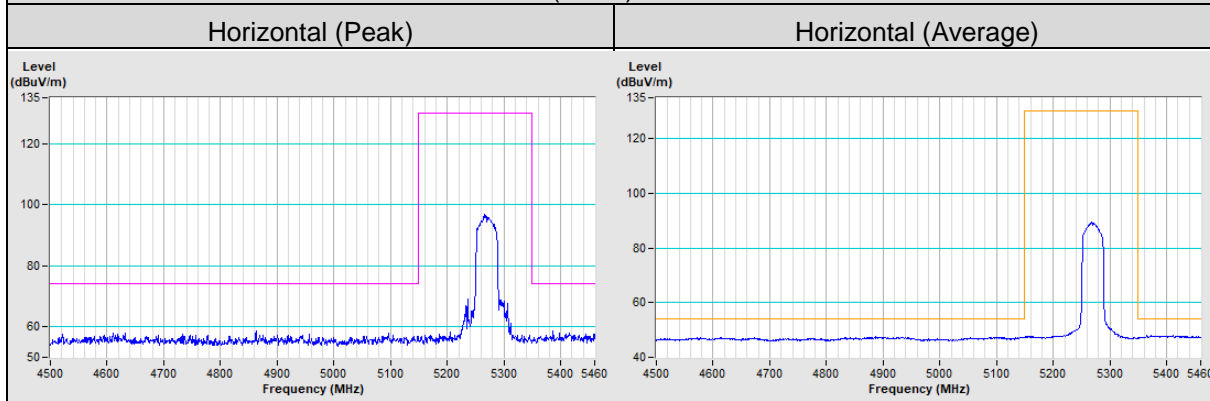

802.11n (HT40) Channel 62

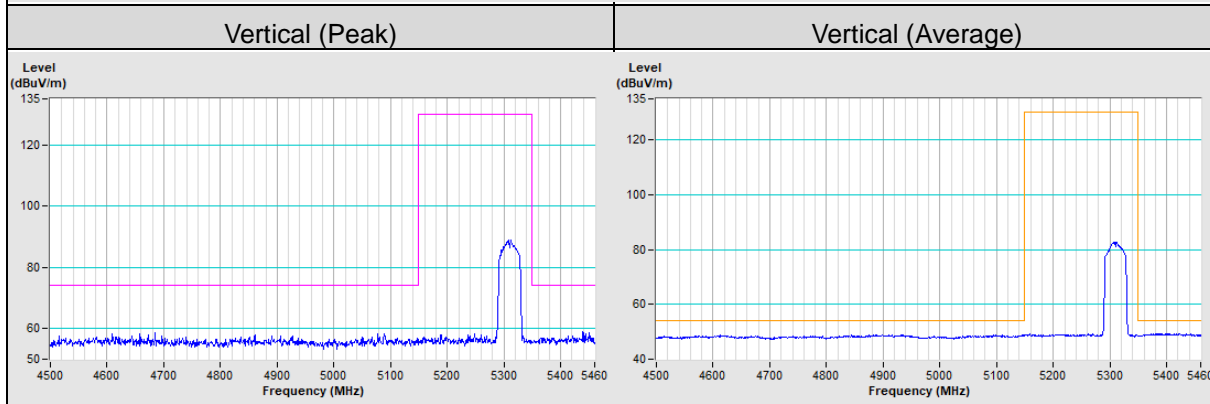
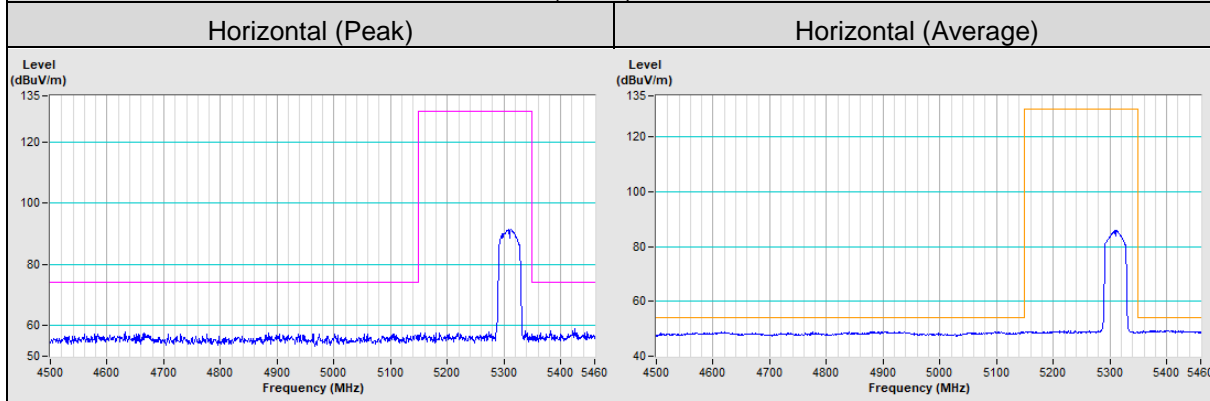

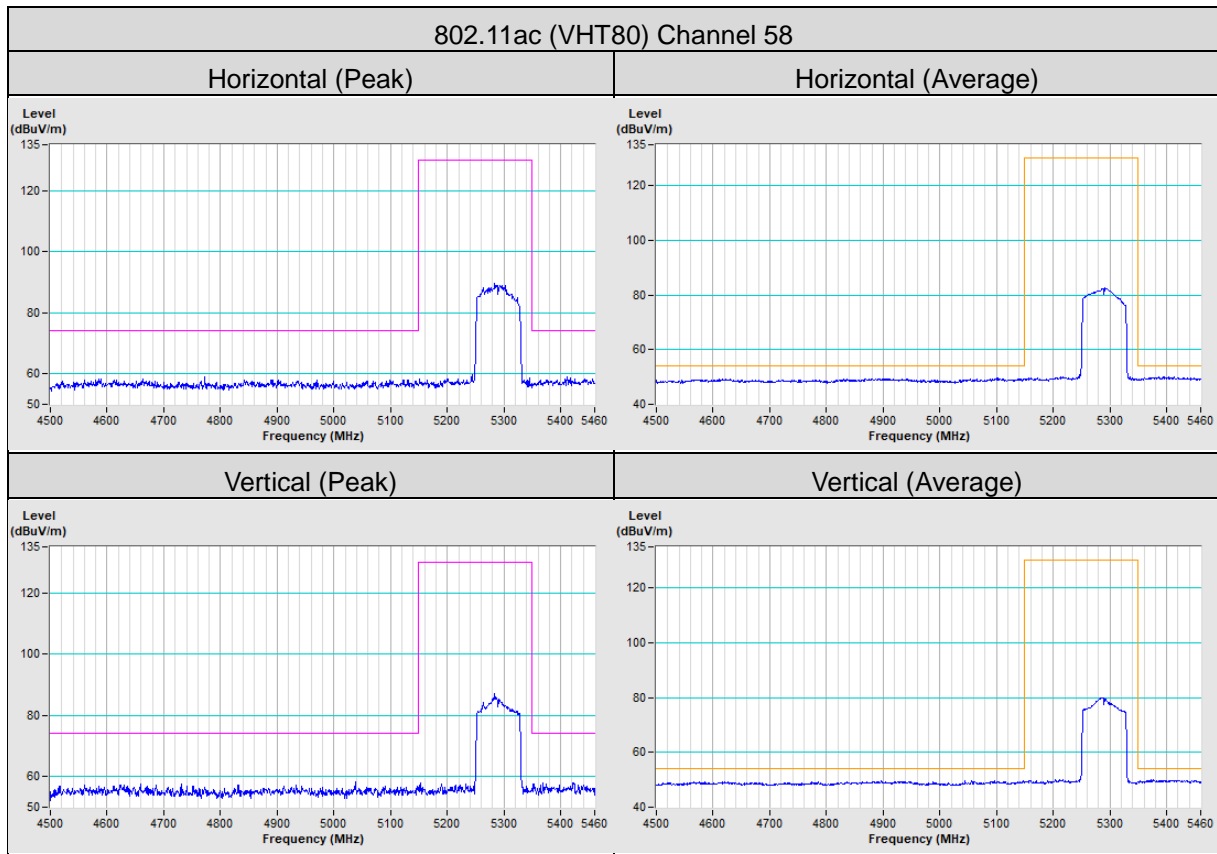

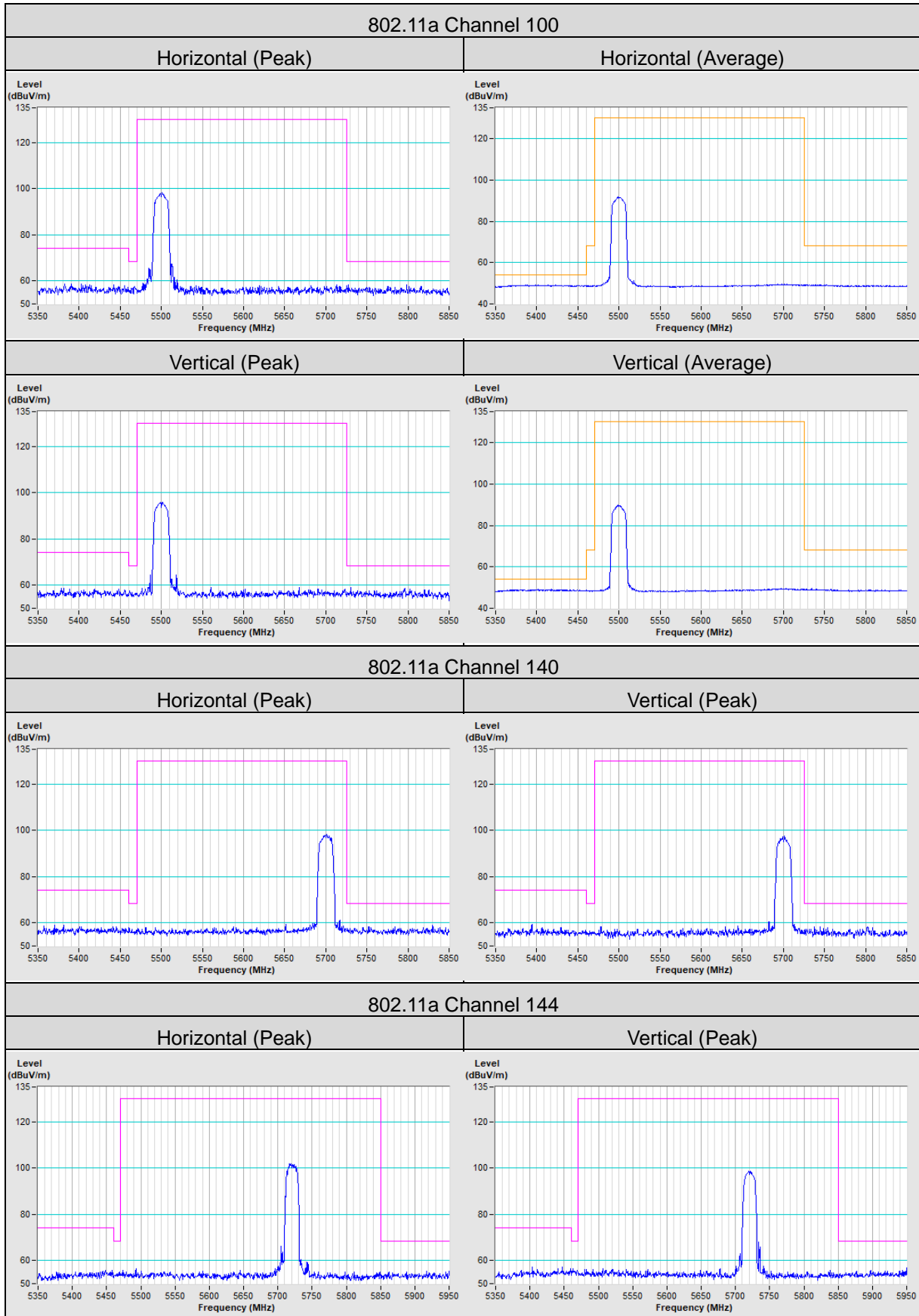

802.11n (HT20) Channel 100

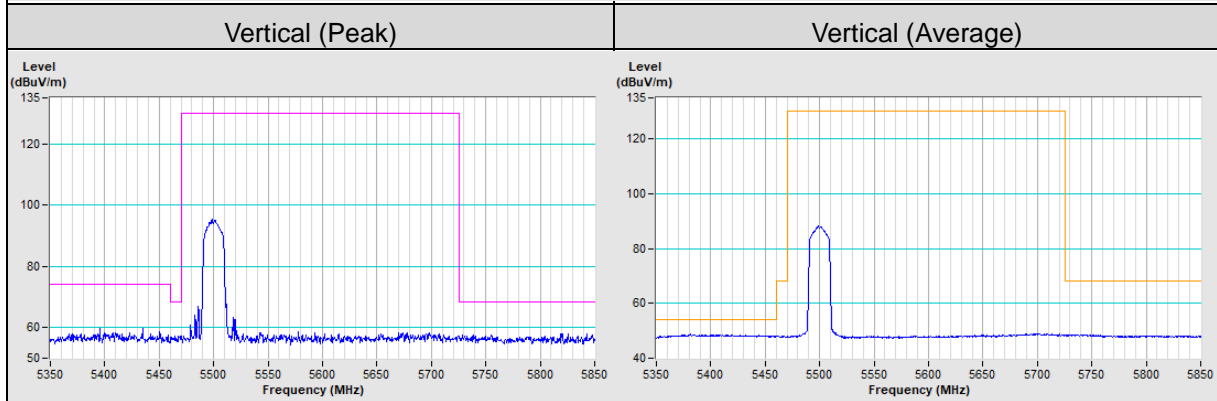
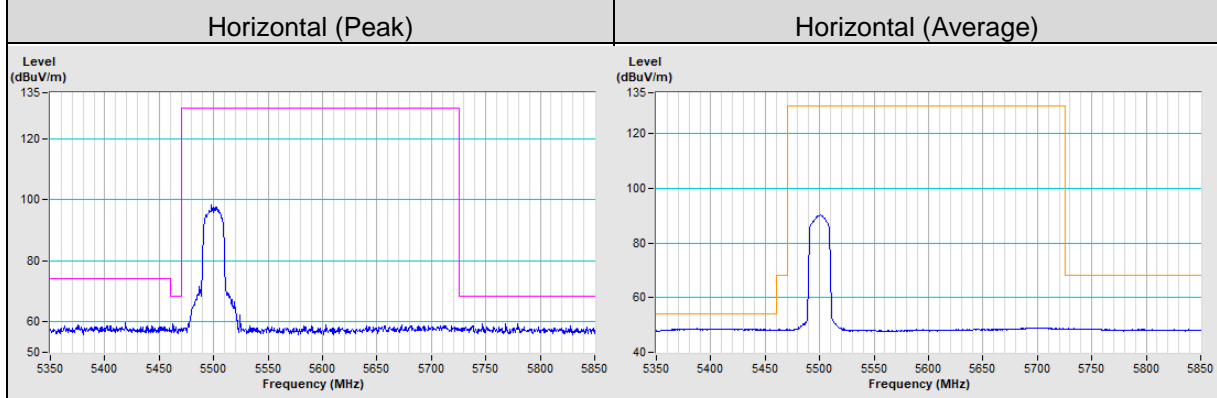

802.11n (HT20) Channel 140

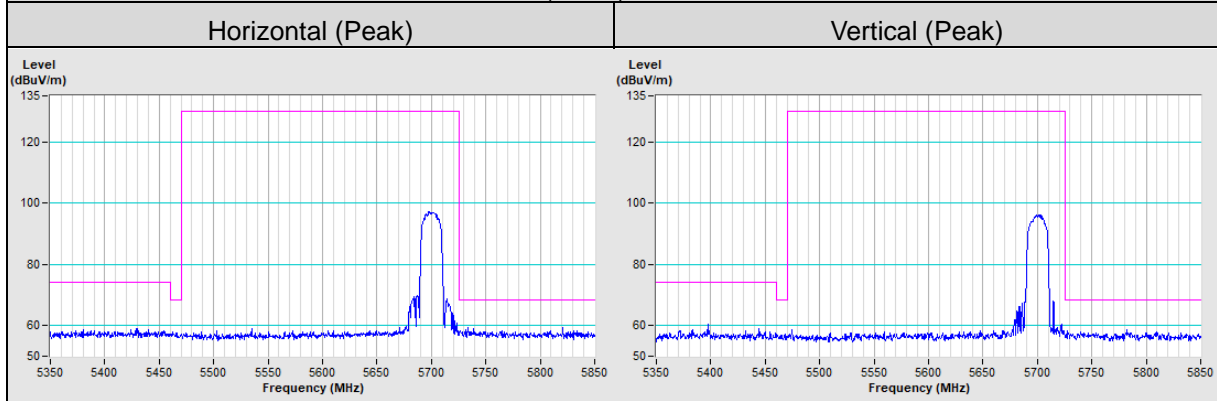

802.11n (HT20) Channel 144

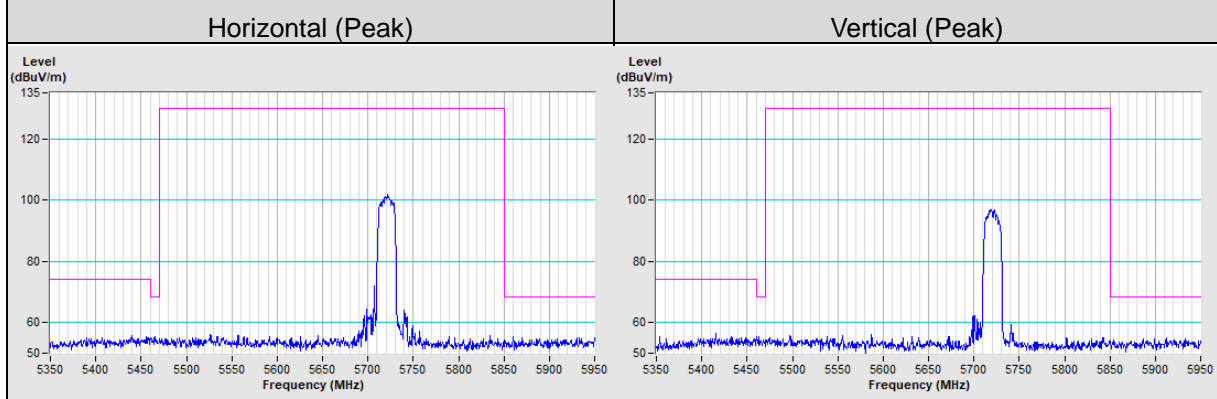

802.11n (HT40) Channel 102

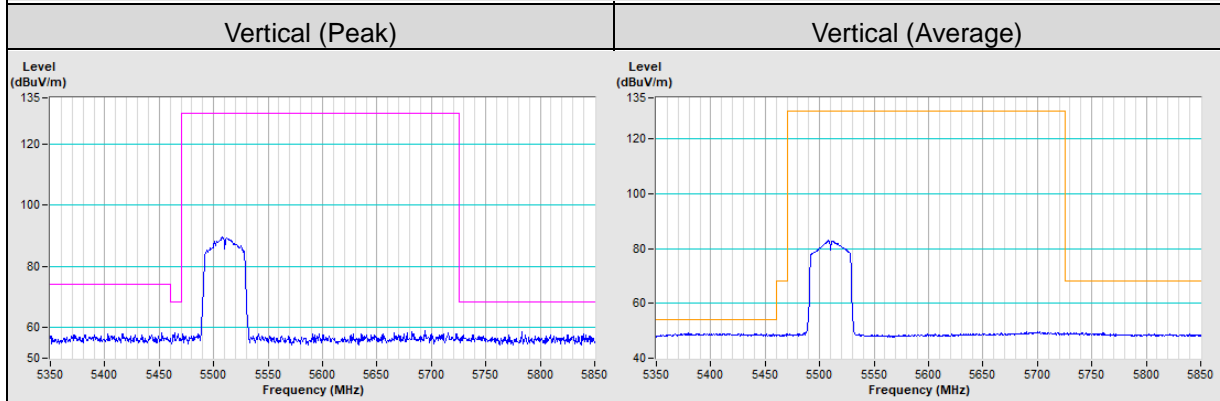
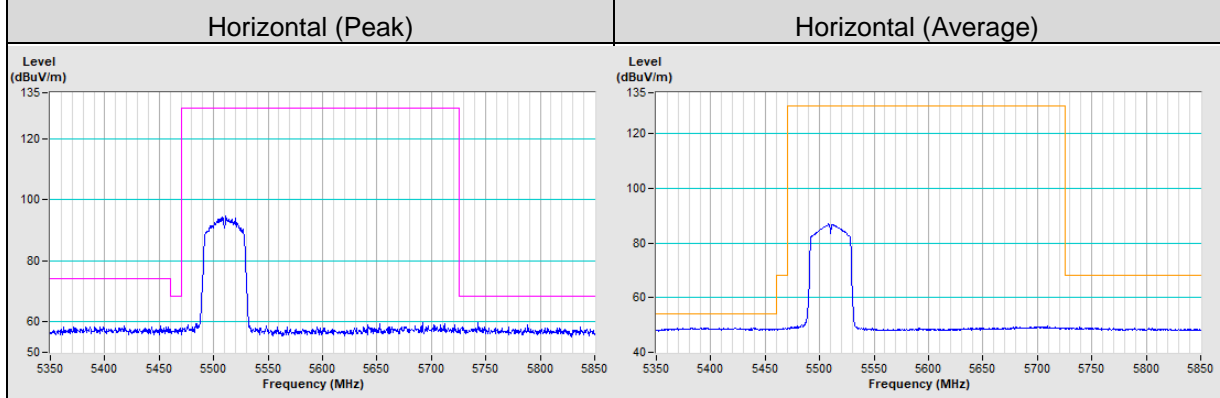

802.11n (HT40) Channel 134

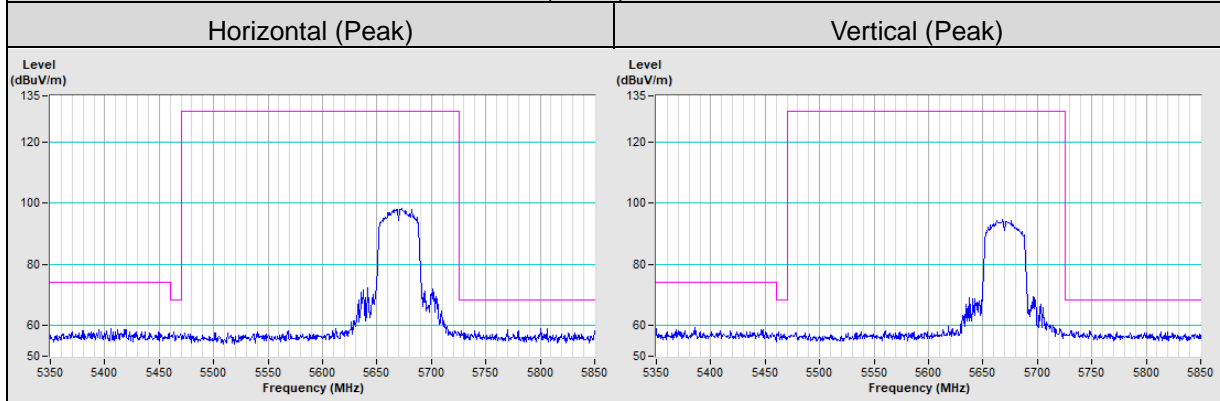

802.11n (HT40) Channel 142

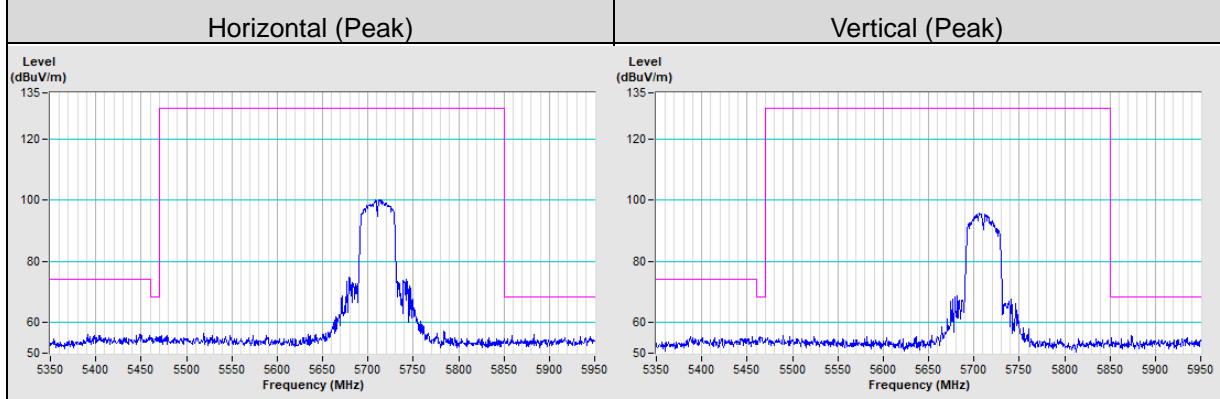

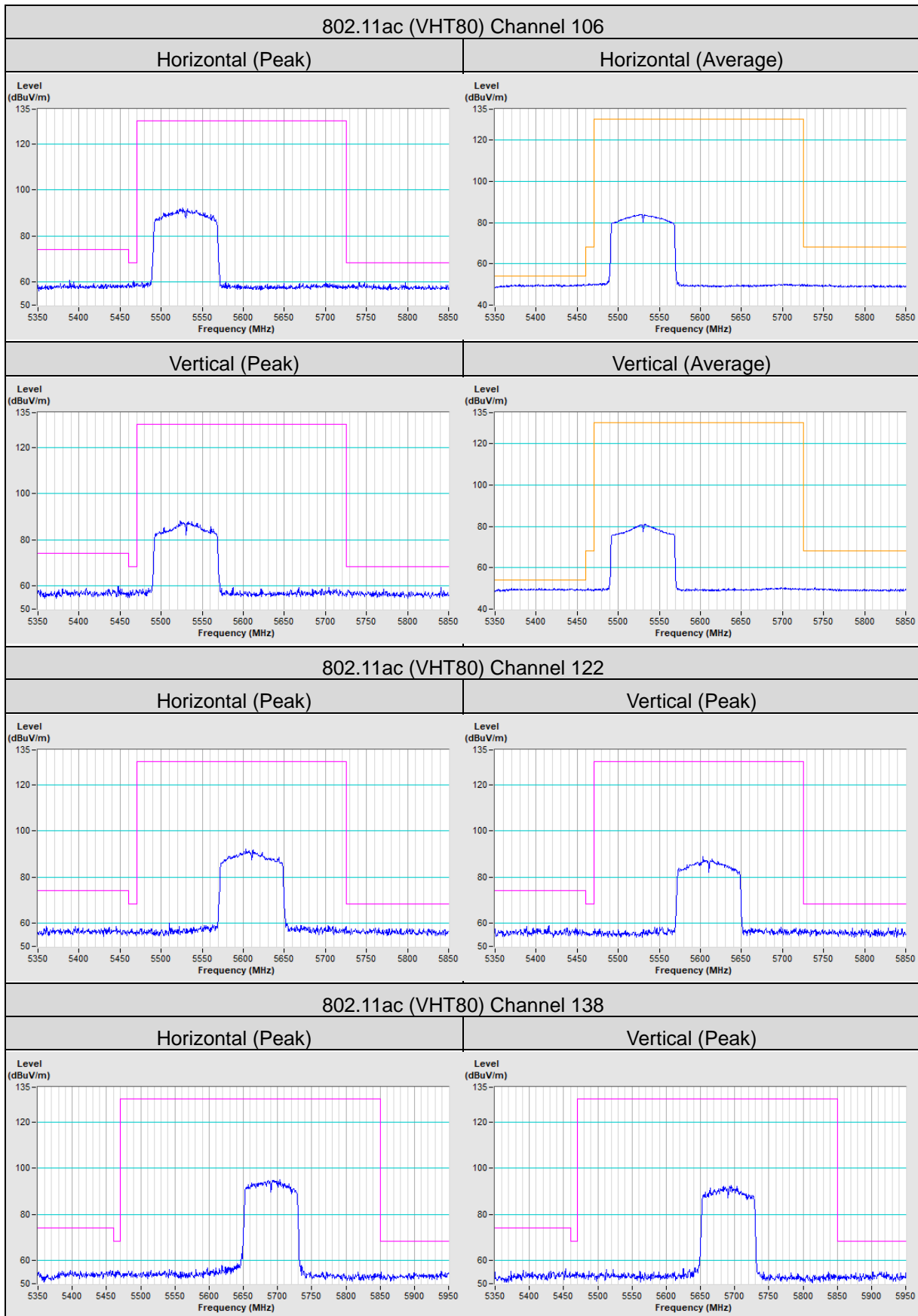

7.11 Radiated Out of Band Emission (OOBE) Measurement (For U-NII-3 band)

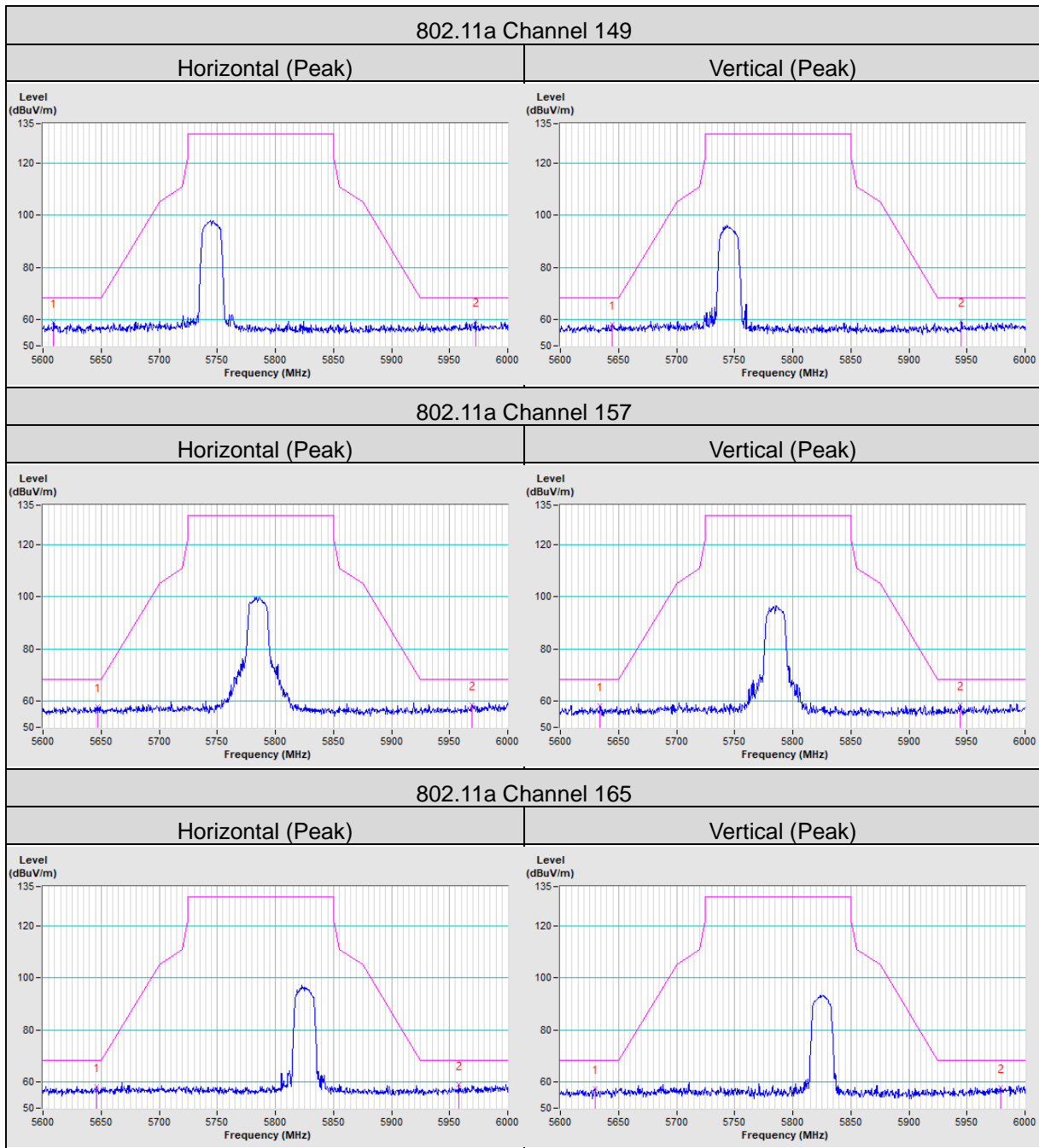

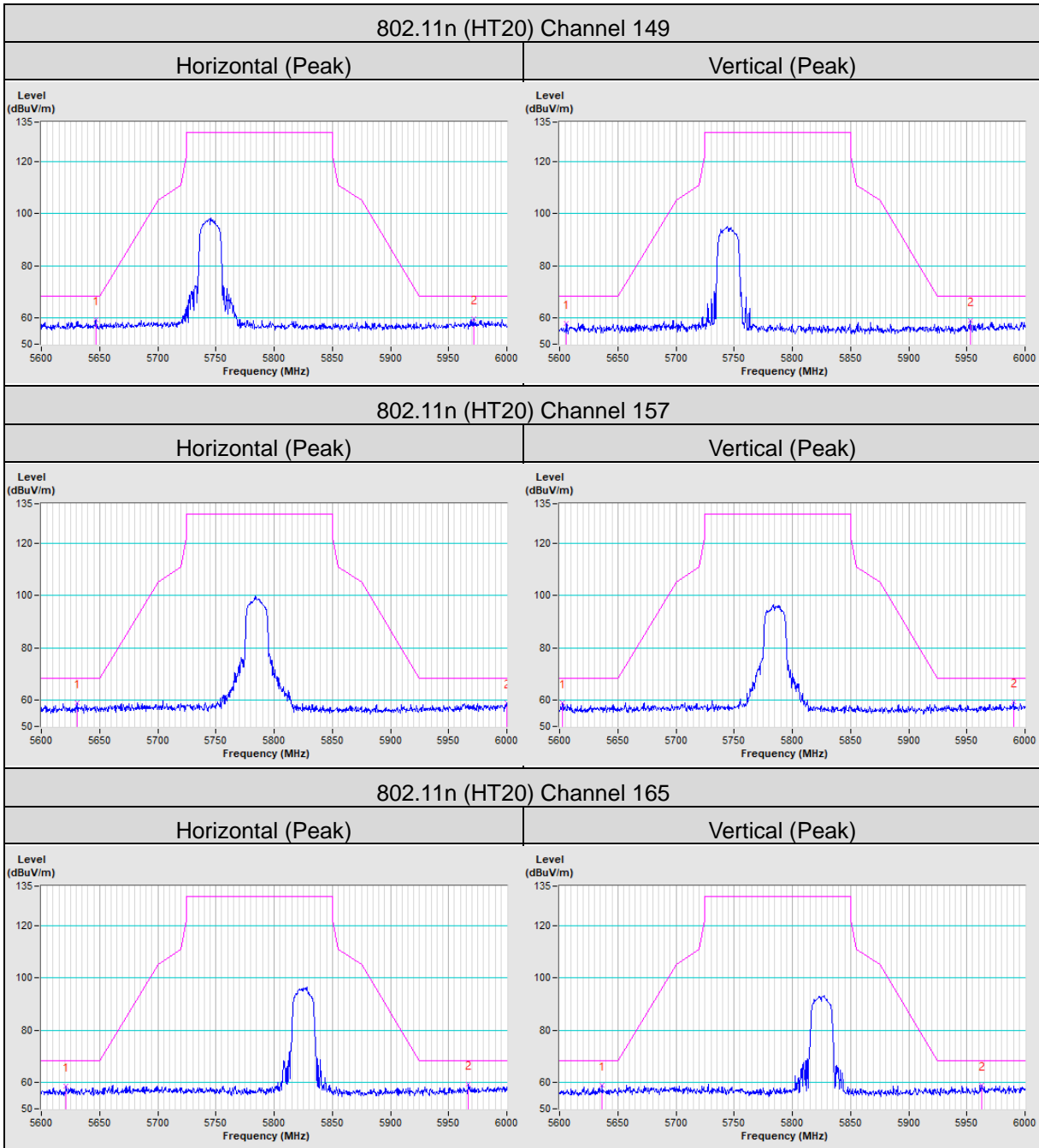

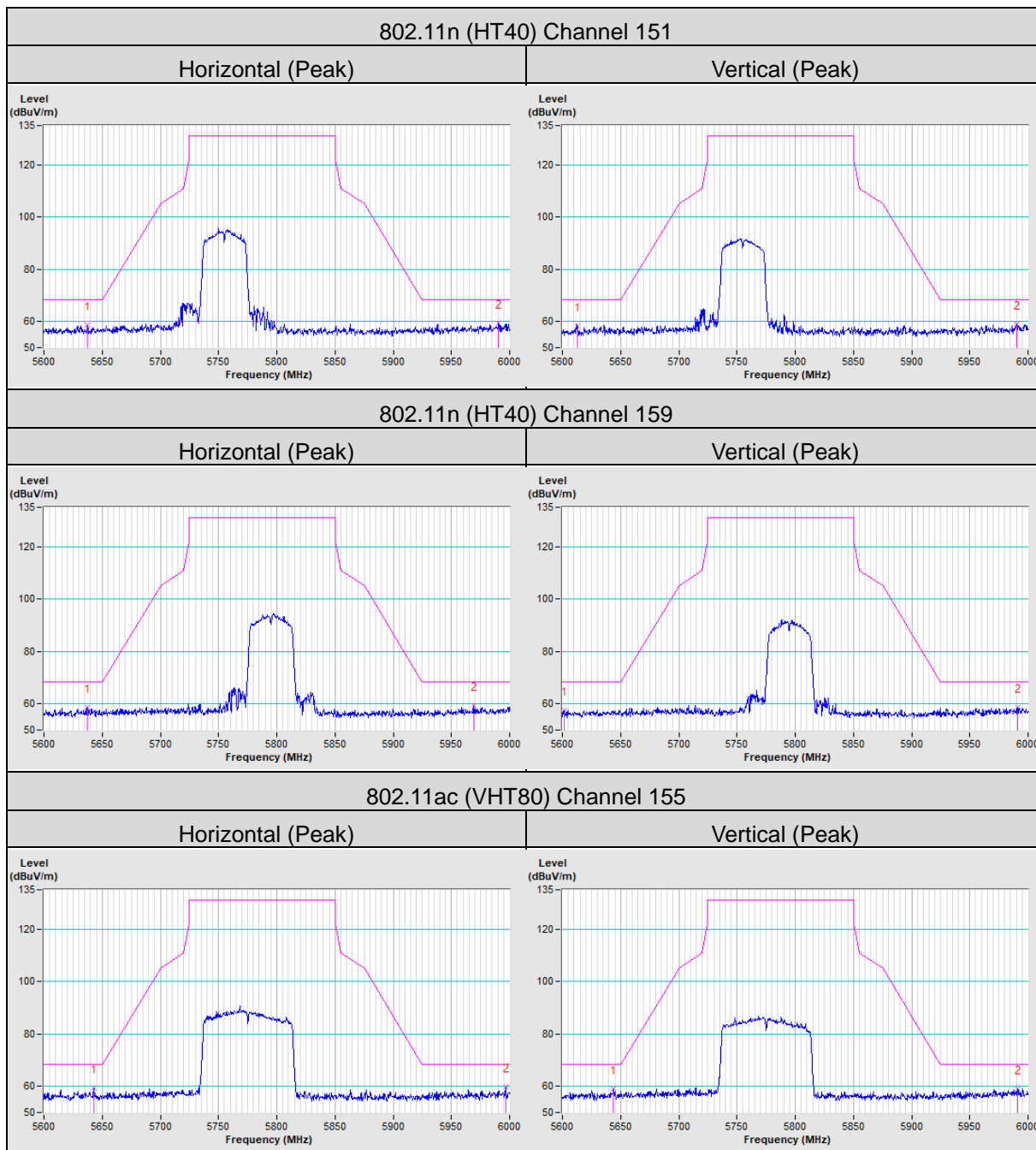

8 Pictures of Test Arrangements

Please refer to the attached file (Test Setup Photo)

9 Information of the Testing Laboratories

We, Bureau Veritas Consumer Products Services (H.K.) Ltd., Taoyuan Branch, were founded in 1988 to provide our best service in EMC, Radio, Telecom and Safety consultation. Our laboratories are FCC recognized accredited test firms and accredited according to ISO/IEC 17025.

If you have any comments, please feel free to contact us at the following:

Lin Kou EMC/RF Lab

Tel: 886-2-26052180

Fax: 886-2-26051924

Hsin Chu EMC/RF/Telecom Lab

Tel: 886-3-6668565

Fax: 886-3-6668323

Hwa Ya EMC/RF/Safety Lab

Tel: 886-3-3183232

Fax: 886-3-3270892

Email: service.adt@bureauveritas.com

Web Site: <http://ee.bureauveritas.com.tw>

The address and road map of all our labs can be found in our web site also.

--- END ---