

FCC Test Report

(PART 22)

Report No.: RF170328C23-4

FCC ID: V65E4750

Test Model: E4750

Received Date: Mar. 28, 2017

Test Date: Apr. 11, 2017 ~ Apr. 21, 2017

Issued Date: May 02, 2017

Applicant: Kyocera Corporation c/o Kyocera International, Inc.

Address: 8611 Balboa Avenue, San Diego, CA 92123

Issued By: Bureau Veritas Consumer Products Services (H.K.) Ltd., Taoyuan Branch

Lab Address: No. 47-2, 14th Ling, Chia Pau Vil., Lin Kou Dist., New Taipei City, Taiwan
(R.O.C)

Test Location (1): No. 19, Hwa Ya 2nd Rd, Wen Hwa Tsuen, Kwei Shan Hsiang, Taoyuan
Hsien 333, Taiwan, R.O.C.

Test Location (2): No.215, Sec. 3, Beixin Rd., Xindian Dist., New Taipei City 231, Taiwan,
R.O.C



This report is for your exclusive use. Any copying or replication of this report to or for any other person or entity, or use of our name or trademark, is permitted only with our prior written permission. This report sets forth our findings solely with respect to the test samples identified herein. The results set forth in this report are not indicative or representative of the quality or characteristics of the lot from which a test sample was taken or any similar or identical product unless specifically and expressly noted. Our report includes all of the tests requested by you and the results thereof based upon the information that you provided to us. You have 60 days from date of issuance of this report to notify us of any material error or omission caused by our negligence, provided, however, that such notice shall be in writing and shall specifically address the issue you wish to raise. A failure to raise such issue within the prescribed time shall constitute your unqualified acceptance of the completeness of this report, the tests conducted and the correctness of the report contents. Unless specific mention, the uncertainty of measurement has been explicitly taken into account to declare the compliance or non-compliance to the specification. The report must not be used by the client to claim product certification, approval, or endorsement by TAF or any government agencies

Table of Contents

Release Control Record	3
1 Certificate of Conformity	4
2 Summary of Test Results	5
2.1 Measurement Uncertainty	5
2.2 Test Site and Instruments	6
3 General Information	8
3.1 General Description of EUT	8
3.2 Configuration of System under Test.....	10
3.2.1 Description of Support Units.....	10
3.3 Test Mode Applicability and Tested Channel Detail	11
3.4 EUT Operating Conditions	14
3.5 General Description of Applied Standards.....	14
4 Test Types and Results	15
4.1 Output Power Measurement.....	15
4.1.1 Limits of Output Power Measurement	15
4.1.2 Test Procedures.....	15
4.1.3 Test Setup.....	16
4.1.4 Test Results	17
4.2 Frequency Stability Measurement	26
4.2.1 Limits of Frequency Stability Measurement.....	26
4.2.2 Test Procedure	26
4.2.3 Test Setup.....	26
4.2.4 Test Results	27
4.3 Occupied Bandwidth Measurement.....	38
4.3.1 Test Procedure	38
4.3.2 Test Setup.....	38
4.3.3 Test Result	39
4.4 Band Edge Measurement	45
4.4.1 Limits of Band Edge Measurement	45
4.4.2 Test Setup.....	45
4.4.3 Test Procedures.....	45
4.4.4 Test Results	46
4.5 Peak to Average Ratio	56
4.5.1 Limits of Peak to Average Ratio Measurement	56
4.5.2 Test Setup.....	56
4.5.3 Test Procedures.....	56
4.5.4 Test Results	57
4.6 Conducted Spurious Emissions.....	63
4.6.1 Limits of Conducted Spurious Emissions Measurement.....	63
4.6.2 Test Setup.....	63
4.6.3 Test Procedure	63
4.6.4 Test Results	64
4.7 Radiated Emission Measurement.....	75
4.7.1 Limits of Radiated Emission Measurement	75
4.7.2 Test Procedure	75
4.7.3 Deviation from Test Standard	75
4.7.4 Test Setup.....	75
4.7.5 Test Results	76
5 Pictures of Test Arrangements	100
Appendix – Information on the Testing Laboratories	101



Release Control Record

Issue No.	Description	Date Issued
RF170328C23-4	Original Release	May 02, 2017



1 Certificate of Conformity

Product: Feature Phone

Brand: KYOCERA

Test Model: E4750

Sample Status: Identical Prototype

Applicant: Kyocera Corporation c/o Kyocera International, Inc.

Test Date: Apr. 11, 2017 ~ Apr. 21, 2017

Standards: FCC Part 22, Subpart H

The above equipment has been tested by **Bureau Veritas Consumer Products Services (H.K.) Ltd., Taoyuan Branch**, and found compliance with the requirement of the above standards. The test record, data evaluation & Equipment Under Test (EUT) configurations represented herein are true and accurate accounts of the measurements of the sample's EMC characteristics under the conditions specified in this report.

Prepared by : Evonne Liu , **Date:** May 02, 2017
Evonne Liu / Specialist

Approved by : David Huang , **Date:** May 02, 2017
David Huang / Project Engineer

2 Summary of Test Results

Applied Standard: FCC Part 22 & Part 2			
FCC Clause	Test Item	Result	Remarks
2.1046 22.913 (a)	Effective Radiated Power	Pass	Meet the requirement of limit.
---	Peak to Average Ratio	Pass	Meet the requirement of limit.
2.1055 22.355	Frequency Stability	Pass	Meet the requirement of limit.
2.1049	Occupied Bandwidth	Pass	Meet the requirement of limit.
22.917	Band Edge Measurements	Pass	Meet the requirement of limit.
2.1051 22.917	Conducted Spurious Emissions	Pass	Meet the requirement of limit.
2.1053 22.917	Radiated Spurious Emissions	Pass	Meet the requirement of limit. Minimum passing margin is -32.90 dB at 2524.50 MHz.

2.1 Measurement Uncertainty

Where relevant, the following measurement uncertainty levels have been estimated for tests performed on the EUT as specified in CISPR 16-4-2:

Measurement	Frequency	Expanded Uncertainty (k=2) (±)
Conducted Emissions at mains ports	150 kHz ~ 30 MHz	2.44 dB
Radiated Emissions up to 1 GHz	30 MHz ~ 200 MHz	2.0153 dB
	200 MHz ~ 1000 MHz	2.0224 dB
Radiated Emissions above 1 GHz	1 GHz ~ 18 GHz	1.0121 dB
	18 GHz ~ 40 GHz	1.1508 dB

2.2 Test Site and Instruments

Description & Manufacturer	Model No.	Serial No.	Date of Calibration	Due Date of Calibration
Test Receiver Agilent Technologies	N9038A	MY52260177	Jun. 21, 2016	Jun. 20, 2017
Spectrum Analyzer ROHDE & SCHWARZ	FSU43	101261	Dec. 13, 2016	Dec. 12, 2017
BILOG Antenna SCHWARZBECK	VULB9168	9168-472	Dec. 16, 2016	Dec. 15, 2017
HORN Antenna ETS-Lindgren	3117	00143293	Dec. 29, 2016	Dec. 28, 2017
Double Ridge Guide Horn Antenna EMCO	3115	5619	Dec. 27, 2016	Dec. 26, 2017
BILOG Antenna SCHWARZBECK	VULB 9168	9168-153	Dec. 13, 2016	Dec. 12, 2017
Fixed Attenuator Mini-Circuits	BW-N10W5+	NA	Jul. 08, 2016	Jul. 07, 2017
MXG Vector signal generator Agilent	N5182B	MY53050430	Oct. 19, 2016	Oct. 18, 2017
Preamplifier Agilent	310N	187226	Jun. 24, 2016	Jun. 23, 2017
Preamplifier Agilent	83017A	MY39501357	Jun. 24, 2016	Jun. 23, 2017
Power Meter Anritsu	ML2495A	1232002	Sep. 08, 2016	Sep. 07, 2017
Power Sensor Anritsu	MA2411B	1207325	Sep. 08, 2016	Sep. 07, 2017
RF signal cable ETS-LINDGREN	5D-FB	Cable-CH1-01(R FC-SMS-100-SM S-120+RFC-SMS -100-SMS-400)	Jun. 24, 2016	Jun. 23, 2017
RF signal cable ETS-LINDGREN	8D-FB	Cable-CH1-02(R FC-SMS-100-SM S-24)	Jun. 24, 2016	Jun. 23, 2017
Software BV ADT	E3 8.130425b	NA	NA	NA
Antenna Tower MF	NA	NA	NA	NA
Turn Table MF	NA	NA	NA	NA
Antenna Tower & Turn Table Controller MF	MF-7802	NA	NA	NA
Communications Tester-Wireless Agilent	8960 Series 10	MY53201073	Jul. 03, 2015	Jul. 02, 2017
Radio Communication Analyzer Anritsu	MT8820C	6201300640	Aug. 10, 2015	Aug. 09, 2017
Temperature & Humidity Chamber	GTH-120-40-CP-A R	MAA1306-019	Sep. 02, 2016	Sep. 01, 2017
DC Power Supply Topward	33010D	807748	Oct. 25, 2016	Oct. 24, 2018
Digital Multimeter Fluke	87-III	70360742	Jul. 01, 2016	Jun. 30, 2017

- Note:
1. The calibration interval of the above test instruments is 12 / 24 months and the calibrations are traceable to NML/ROC and NIST/USA.
 2. The test was performed in HsinTien Chamber 1.
 3. The horn antenna and preamplifier (model: 83017A) are used only for the measurement of emission frequency above 1 GHz if tested.
 4. The FCC Site Registration No. is 149147.
 5. The IC Site Registration No. is IC7450I-1.

3 General Information

3.1 General Description of EUT

Product	Feature Phone	
Brand	KYOCERA	
Test Model	E4750	
Status of EUT	Identical Prototype	
Power Supply Rating	5.0 Vdc (adapter) 3.8 Vdc (Li-ion battery)	
Modulation Type	WCDMA	BPSK
	CDMA	QPSK, OPQKS, HPSK
	LTE	QPSK, 16QAM
Frequency Range	WCDMA	826.4 ~ 846.6 MHz
	CDMA	824.7 ~ 848.31 MHz
	LTE 5 (Channel Bandwidth: 1.4 MHz)	824.7 ~ 848.3 MHz
	LTE 5 (Channel Bandwidth: 3 MHz)	825.5 ~ 847.5 MHz
	LTE 5 (Channel Bandwidth: 5 MHz)	826.5 ~ 846.5 MHz
	LTE 5 (Channel Bandwidth: 10 MHz)	829 ~ 844 MHz
	LTE 26 (Channel Bandwidth: 1.4 MHz)	824.7 ~ 848.3 MHz
	LTE 26 (Channel Bandwidth: 3 MHz)	825.5 ~ 847.5 MHz
	LTE 26 (Channel Bandwidth: 5 MHz)	826.5 ~ 846.5 MHz
	LTE 26 (Channel Bandwidth: 10 MHz)	829 ~ 844 MHz
	LTE 26 (Channel Bandwidth: 15 MHz)	831.5 ~ 841.5 MHz
Max. ERP Power	WCDMA	221.92 mW
	CDMA	227.40 mW
	LTE 5 (Channel Bandwidth: 1.4 MHz)	226.05 mW
	LTE 5 (Channel Bandwidth: 3 MHz)	221.31 mW
	LTE 5 (Channel Bandwidth: 5 MHz)	222.43 mW
	LTE 5 (Channel Bandwidth: 10 MHz)	225.42 mW
	LTE 26 (Channel Bandwidth: 1.4 MHz)	204.27 mW
	LTE 26 (Channel Bandwidth: 3 MHz)	202.77 mW
	LTE 26 (Channel Bandwidth: 5 MHz)	200.91 mW
	LTE 26 (Channel Bandwidth: 10 MHz)	202.77 mW
LTE 26 (Channel Bandwidth: 15 MHz)	202.30 mW	
Emission Designator	WCDMA	4M17F9W
	CDMA	1M28F9W
	LTE 5 (Channel Bandwidth: 1.4 MHz)	1M09G7D
	LTE 5 (Channel Bandwidth: 3 MHz)	2M70G7D
	LTE 5 (Channel Bandwidth: 5 MHz)	4M49G7D
	LTE 5 (Channel Bandwidth: 10 MHz)	8M96G7D
	LTE 26 (Channel Bandwidth: 1.4 MHz)	1M09W7D
	LTE 26 (Channel Bandwidth: 3 MHz)	2M70G7D
	LTE 26 (Channel Bandwidth: 5 MHz)	4M49W7D
	LTE 26 (Channel Bandwidth: 10 MHz)	8M97G7D
LTE 26 (Channel Bandwidth: 15 MHz)	13M5G7D	

Antenna Type	Fixed Internal Antenna
Accessory Device	Refer to Note as below
Data Cable Supplied	Refer to Note as below

Note:

1. The EUT contains following accessory devices.

Product	Brand	Model	Description
Adapter	KYOCERA	SCP-50ADT	I/P: 100-240 Vac, 50/60 Hz, 0.25 A O/P: 5 Vdc, 1.5 A
Battery	KYOCERA	SCP-71LBPS	3.8 Vdc, 11.02 Wh
USB Cable	KYOCERA	SCP-22SDC	1 m shielded cable w/o core

2. The above EUT information is declared by manufacturer and for more detailed features description, please refer to the manufacturer's specifications or user's manual.

3.2 Configuration of System under Test

<Radiated Emission Test>

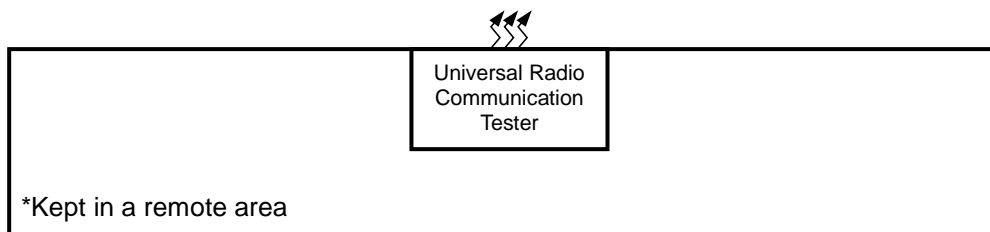
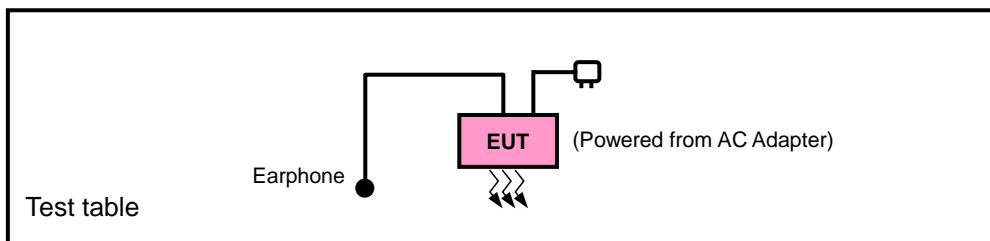

<E.R.P. Test>

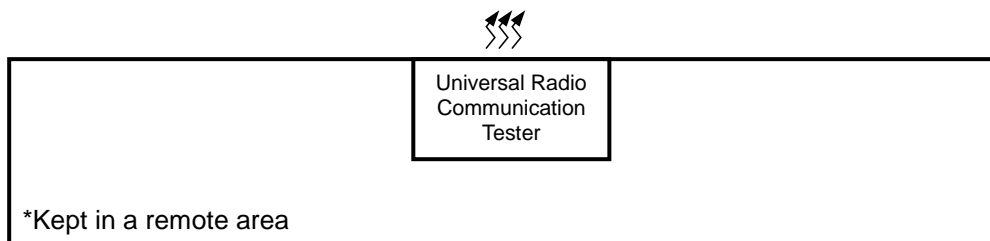
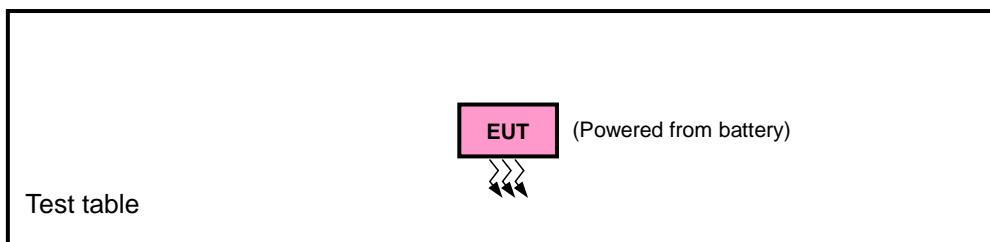

3.2.1 Description of Support Units

The EUT has been tested as an independent unit together with other necessary accessories or support units.

3.3 Test Mode Applicability and Tested Channel Detail

Pre-Scan has been conducted to determine the worst-case mode from all possible combinations between available modulations, data rates, XYZ axis, and antenna ports.

The worst case was found when positioned as the table below. Following channel(s) was (were) selected for the final test as listed below:

Band	ERP	Radiated Emission
WCDMA	Y-plane	Y-axis
CDMA	Y-plane	Z-axis
LTE Band 5	Y-plane	X-axis
LTE Band 26	X-plane	Z-axis

WCDMA

EUT Configure Mode	Test Item	Available Channel	Tested Channel	Mode
-	ERP	4132 to 4233	4132, 4182, 4233	WCDMA
-	Frequency Stability	4132 to 4233	4132, 4233	WCDMA
-	Occupied Bandwidth	4132 to 4233	4132, 4182, 4233	WCDMA
-	Band Edge	4132 to 4233	4132, 4233	WCDMA
-	Peak to Average Ratio	4132 to 4233	4132, 4182, 4233	WCDMA
-	Condcudeted Emission	4132 to 4233	4132, 4182, 4233	WCDMA
-	Radiated Emission	4132 to 4233	4132, 4182, 4233	WCDMA

CDMA

EUT Configure Mode	Test Item	Available Channel	Tested Channel	Mode
-	ERP	1013 to 777	1013, 384, 777	1xRTT
-	Frequency Stability	1013 to 777	1013, 777	1xRTT
-	Occupied Bandwidth	1013 to 777	1013, 384, 777	1xRTT
-	Band Edge	1013 to 777	1013, 777	1xRTT
-	Peak to Average Ratio	1013 to 777	1013, 384, 777	1xRTT
-	Condcudeted Emission	1013 to 777	1013, 384, 777	1xRTT
-	Radiated Emission	1013 to 777	1013, 384, 777	1xRTT

LTE Band 5

EUT Configure Mode	Test Item	Available Channel	Tested Channel	Channel Bandwidth	Modulation	Mode		
-	ERP	20407 to 20643	20407, 20525, 20643	1.4 MHz	QPSK, 16QAM	1 RB / 2 RB Offset		
		20415 to 20635	20415, 20525, 20635	3 MHz	QPSK, 16QAM	1 RB / 7 RB Offset		
		20425 to 20625	20425, 20525, 20625	5 MHz	QPSK, 16QAM	1 RB / 12 RB Offset		
		20450 to 20600	20450, 20525, 20600	10 MHz	QPSK, 16QAM	1 RB / 24 RB Offset		
-	Frequency Stability	20407 to 20643	20407, 20643	1.4 MHz	QPSK	1 RB / 2 RB Offset		
		20415 to 20635	20415, 20635	3 MHz	QPSK	1 RB / 7 RB Offset		
		20425 to 20625	20425, 20625	5 MHz	QPSK	1 RB / 12 RB Offset		
		20450 to 20600	20450, 20600	10 MHz	QPSK	1 RB / 24 RB Offset		
-	Occupied Bandwidth	20407 to 20643	20407, 20525, 20643	1.4 MHz	QPSK, 16QAM	6 RB / 0 RB Offset		
		20415 to 20635	20415, 20525, 20635	3 MHz	QPSK, 16QAM	15 RB / 0 RB Offset		
		20425 to 20625	20425, 20525, 20625	5 MHz	QPSK, 16QAM	25 RB / 0 RB Offset		
		20450 to 20600	20450, 20525, 20600	10 MHz	QPSK, 16QAM	50 RB / 0 RB Offset		
-	Band Edge	20407 to 20643	20407	1.4MHz	QPSK	1 RB / 0 RB Offset 6 RB / 0 RB Offset		
			20643	1.4MHz	QPSK	1 RB / 5 RB Offset 6 RB / 0 RB Offset		
		20415 to 20635	20415	3 MHz	QPSK	1 RB / 0 RB Offset 15 RB / 0 RB Offset		
			20635	3 MHz	QPSK	1 RB / 14 RB Offset 15 RB / 0 RB Offset		
		20425 to 20625	20425	5 MHz	QPSK	1 RB / 0 RB Offset 25 RB / 0 RB Offset		
			20625	5 MHz	QPSK	1 RB / 24 RB Offset 25 RB / 0 RB Offset		
		20450 to 20600	20450	10 MHz	QPSK	1 RB / 0 RB Offset 50 RB / 0 RB Offset		
			20600	10 MHz	QPSK	1 RB / 49 RB Offset 50 RB / 0 RB Offset		
		-	Peak to Average Ratio	20407 to 20643	20407, 20525, 20643	1.4 MHz	QPSK, 16QAM	6 RB / 0 RB Offset
				20415 to 20635	20415, 20525, 20635	3 MHz	QPSK, 16QAM	15 RB / 0 RB Offset
				20425 to 20625	20425, 20525, 20625	5 MHz	QPSK, 16QAM	25 RB / 0 RB Offset
				20450 to 20600	20450, 20525, 20600	10 MHz	QPSK, 16QAM	50 RB / 0 RB Offset
-	Conducted Emission	20407 to 20643	20407, 20525, 20643	1.4 MHz	QPSK	1 RB / 2 RB Offset		
		20415 to 20635	20415, 20525, 20635	3 MHz	QPSK	1 RB / 7 RB Offset		
		20425 to 20625	20425, 20525, 20625	5 MHz	QPSK	1 RB / 12 RB Offset		
		20450 to 20600	20450, 20525, 20600	10 MHz	QPSK	1 RB / 24 RB Offset		
-	Radiated Emission	20450 to 20600	20450, 20525, 20600	10 MHz	QPSK	1 RB / 24 RB Offset		

Note: This device was tested under all bandwidths, RB configurations and modulations. The worst case was found in QPSK modulation.

LTE Band 26

EUT Configure Mode	Test Item	Available Channel	Tested Channel	Channel Bandwidth	Modulation	Mode		
-	ERP	26797 to 27033	26797, 26915, 27033	1.4 MHz	QPSK, 16QAM	1 RB / 5 RB Offset		
		26805 to 27025	26805, 26915, 27025	3 MHz	QPSK, 16QAM	1 RB / 14 RB Offset		
		26815 to 27015	26815, 26915, 27015	5 MHz	QPSK, 16QAM	1 RB / 24 RB Offset		
		26840 to 26990	26840, 26915, 26990	10 MHz	QPSK, 16QAM	1 RB / 49 RB Offset		
		26865 to 26965	26865, 26915, 26965	15 MHz	QPSK, 16QAM	1 RB / 49 RB Offset		
-	Frequency Stability	26797 to 27033	26797, 27033	1.4 MHz	QPSK	1 RB / 5 RB Offset		
		26805 to 27025	26805, 27025	3 MHz	QPSK	1 RB / 14 RB Offset		
		26815 to 27015	26815, 27015	5 MHz	QPSK	1 RB / 24 RB Offset		
		26840 to 26990	26840, 26990	10 MHz	QPSK	1 RB / 49 RB Offset		
		26865 to 26965	26865, 26965	15 MHz	QPSK	1 RB / 49 RB Offset		
-	Occupied Bandwidth	26797 to 27033	26797, 26915, 27033	1.4 MHz	QPSK, 16QAM	6 RB / 0 RB Offset		
		26805 to 27025	26805, 26915, 27025	3 MHz	QPSK, 16QAM	15 RB / 0 RB Offset		
		26815 to 27015	26815, 26915, 27015	5 MHz	QPSK, 16QAM	25 RB / 0 RB Offset		
		26840 to 26990	26840, 26915, 26990	10 MHz	QPSK, 16QAM	50 RB / 0 RB Offset		
		26865 to 26965	26865, 26915, 26965	15 MHz	QPSK, 16QAM	75 RB / 0 RB Offset		
-	Band Edge	26797 to 27033	26797	1.4 MHz	QPSK	1 RB / 0 RB Offset 6 RB / 0 RB Offset		
			27033	1.4 MHz	QPSK	1 RB / 5 RB Offset 6 RB / 0 RB Offset		
		26805 to 27025	26805	3 MHz	QPSK	1 RB / 0 RB Offset 15 RB / 0 RB Offset		
			27025	3 MHz	QPSK	1 RB / 14 RB Offset 15 RB / 0 RB Offset		
		26815 to 27015	26815	5 MHz	QPSK	1 RB / 0 RB Offset 25 RB / 0 RB Offset		
			27015	5 MHz	QPSK	1 RB / 24 RB Offset 25 RB / 0 RB Offset		
		26840 to 26990	26840	10 MHz	QPSK	1 RB / 0 RB Offset 50 RB / 0 RB Offset		
			26990	10 MHz	QPSK	1 RB / 49 RB Offset 50 RB / 0 RB Offset		
		26865 to 26965	26865	15 MHz	QPSK	1 RB / 0 RB Offset 75 RB / 0 RB Offset		
			26965	15 MHz	QPSK	1 RB / 74 RB Offset 75 RB / 0 RB Offset		
		-	Peak to Average Ratio	26797 to 27033	26797, 26915, 27033	1.4 MHz	QPSK, 16QAM	1 RB / 0 RB Offset
				26805 to 27025	26805, 26915, 27025	3 MHz	QPSK, 16QAM	15 RB / 0 RB Offset
				26815 to 27015	26815, 26915, 27015	5 MHz	QPSK, 16QAM	25 RB / 0 RB Offset
				26840 to 26990	26840, 26915, 26990	10 MHz	QPSK, 16QAM	50 RB / 0 RB Offset
26865 to 26965	26865, 26915, 26965			15 MHz	QPSK, 16QAM	75 RB / 0 RB Offset		
-	Conducted Emission	26797 to 27033	26797, 26915, 27033	1.4 MHz	QPSK	1 RB / 0 RB Offset		
		26805 to 27025	26805, 26915, 27025	3 MHz	QPSK	15 RB / 0 RB Offset		
		26815 to 27015	26815, 26915, 27015	5 MHz	QPSK	25 RB / 0 RB Offset		
		26840 to 26990	26840, 26915, 26990	10 MHz	QPSK	1 RB / 0 RB Offset		
		26865 to 26965	26865, 26915, 26965	15 MHz	QPSK	25 RB / 0 RB Offset		
-	Radiated Emission	26865 to 26965	26865, 26915, 26965	15 MHz	QPSK	1 RB / 0 RB Offset		

Note: This device was tested under all bandwidths, RB configurations and modulations. The worst case was found in QPSK modulation.

Test Condition:

Test Item	Environmental Conditions	Input Power	Tested By
ERP	25 deg. C, 65 % RH	3.8 Vdc	Anson Lin
Frequency Stability	25 deg. C, 65 % RH	3.8 Vdc	Anson Lin
Occupied Bandwidth	25 deg. C, 65 % RH	3.8 Vdc	Anson Lin
Band Edge	25 deg. C, 65 % RH	3.8 Vdc	Anson Lin
Peak to Average Ratio	25 deg. C, 65 % RH	3.8 Vdc	Anson Lin
Condcudeted Emission	25 deg. C, 65 % RH	3.8 Vdc	Anson Lin
Radiated Emission	25 deg. C, 65 % RH	120 Vac, 60 Hz	Charles Hsiao / Karl Lee

3.4 EUT Operating Conditions

The EUT makes a call to the communication simulator. The communication simulator station system controlled a EUT to export maximum output power under transmission mode and specific channel frequency.

3.5 General Description of Applied Standards

The EUT is a RF Product. According to the specifications of the manufacturer, it must comply with the requirements of the following standards:

FCC 47 CFR Part 2

FCC 47 CFR Part 22

KDB 971168 D01 Power Meas License Digital Systems v02r02

ANSI/TIA/EIA-603-D 2010

Note: All test items have been performed and recorded as per the above standards.

4 Test Types and Results

4.1 Output Power Measurement

4.1.1 Limits of Output Power Measurement

Mobile / Portable station are limited to 7 watts e.r.p.

4.1.2 Test Procedures

EIRP / ERP Measurement:

- a. All measurements were done at low, middle and high operational frequency range. RBW and VBW is 1 MHz for GSM, GPRS & EDGE, and 5 MHz for WCDMA and CDMA, and 10 MHz for LTE mode.
- b. Substitution method is used for E.I.R.P measurement. In the semi-anechoic chamber, EUT placed on the 0.8 m height of Turn Table, rotated the table around 360 degrees to search the maximum radiation power and receiver antenna shall be rotated vertical and horizontal polarization and moved height from 1 m to 4 m to find the maximum polar radiated power. The "Read Value" is the spectrum reading the maximum power value.
- c. The substitution horn antenna is substituted for EUT at the same position and signals generator export the CW signal to the substitution antenna via a tx cable. Rotated the Turn Table and moved receiving antenna to find the maximum radiation power. Adjust output power level of S.G to get a Value of spectrum reading equal to "Read Value" of step b. Record the power level of S.G.
- d. $EIRP = \text{Output power level of S.G} - \text{TX cable loss} + \text{Antenna gain of substitution horn}$. E.R.P power can be calculated from E.I.R.P power by subtracting the gain of dipole, $E.R.P \text{ power} = E.I.P.R \text{ power} - 2.15 \text{ dBi}$.

Conducted Power Measurement:

The EUT was set up for the maximum power with GSM, GPRS, EDGE, WCDMA, CDMA, and LTE link data modulation and link up with simulator. Set the EUT to transmit under low, middle and high channel and record the power level shown on simulator.

4.1.3 Test Setup

EIRP / ERP Measurement:

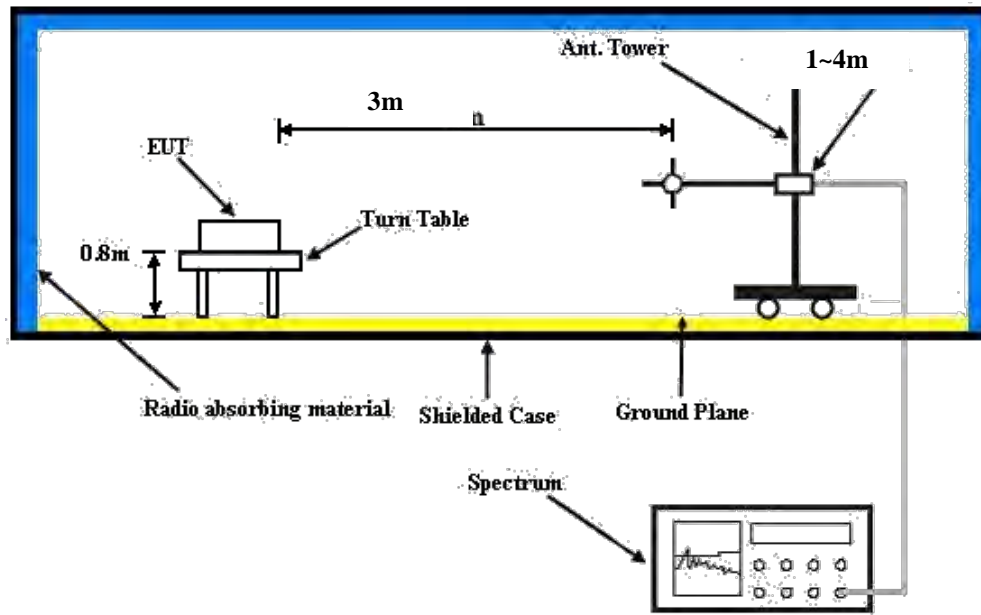

For the actual test configuration, please refer to the attached file (Test Setup Photo).

Conducted Power Measurement:

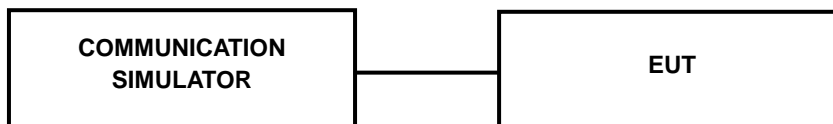

4.1.4 Test Results

Conducted Output Power (dBm)

Band	WCDMA V		
Channel	4132	4182	4233
Frequency (MHz)	826.4	836.4	846.6
RMC 12.2K	23.46	24.42	24.48
HSDPA Subtest-1	22.41	23.41	23.43
HSDPA Subtest-2	22.43	23.35	23.65
HSDPA Subtest-3	21.98	22.93	22.91
HSDPA Subtest-4	21.96	22.92	22.83
HSUPA Subtest-1	22.06	23.27	23.37
HSUPA Subtest-2	21.39	22.28	22.36
HSUPA Subtest-3	21.13	22.14	22.13
HSUPA Subtest-4	21.36	22.28	22.37
HSUPA Subtest-5	22.70	23.60	23.70

Band	CDMA		
Channel	1013	384	777
Frequency (MHz)	824.70	836.52	848.31
RC1+SO55	22.89	24.12	24.14
RC3+SO55	22.95	24.18	24.20
RC3+SO32(+ F-SCH)	22.89	24.10	24.12
RC3+SO32(+SCH)	22.82	24.05	24.08
RTAP 153.6	22.82	24.03	24.05
RETAP 4096	22.77	23.99	24.01

Band / BW	RB Size	RB Offset	QPSK			3GPP MPR (dB)	16QAM			3GPP MPR (dB)
			Low Ch 20407	Mid Ch 20525	High Ch 20643		Low Ch 20407	Mid Ch 20525	High Ch 20643	
			824.7 MHz	836.5 MHz	848.3 MHz		824.7 MHz	836.5 MHz	848.3 MHz	
5 / 1.4M	1	0	22.67	23.32	23.35	0	21.65	22.30	22.33	1
	1	2	22.83	23.88	23.90	0	21.81	22.86	22.88	1
	1	5	23.03	23.90	23.93	0	22.01	22.88	22.91	1
	3	0	22.53	23.51	23.56	0	21.58	22.54	22.56	1
	3	1	22.49	23.42	23.44	0	21.53	22.48	22.43	1
	3	3	22.70	23.56	23.61	0	21.71	22.62	22.63	1
	6	0	21.91	22.87	22.90	1	20.89	21.85	21.88	2

Band / BW	RB Size	RB Offset	QPSK			3GPP MPR (dB)	16QAM			3GPP MPR (dB)
			Low Ch 20415	Mid Ch 20525	High Ch 20635		Low Ch 20415	Mid Ch 20525	High Ch 20635	
			825.5 MHz	836.5 MHz	847.5 MHz		825.5 MHz	836.5 MHz	847.5 MHz	
5 / 3M	1	0	22.72	23.37	23.40	0	21.71	22.34	22.37	1
	1	7	22.88	23.93	23.95	0	21.85	22.90	22.92	1
	1	14	23.08	23.95	23.98	0	22.05	22.92	22.95	1
	8	0	21.92	22.89	22.91	1	20.89	21.86	21.88	2
	8	3	21.89	22.83	22.79	1	20.86	21.80	21.76	2
	8	7	22.08	22.96	22.97	1	21.05	21.93	21.94	2
	15	0	21.96	22.92	22.95	1	20.93	21.89	21.92	2

Band / BW	RB Size	RB Offset	QPSK			3GPP MPR (dB)	16QAM			3GPP MPR (dB)
			Low Ch 20425	Mid Ch 20525	High Ch 20625		Low Ch 20425	Mid Ch 20525	High Ch 20625	
			826.5 MHz	836.5 MHz	846.5 MHz		826.5 MHz	836.5 MHz	846.5 MHz	
5 / 5M	1	0	22.76	23.41	23.44	0	21.73	22.39	22.42	1
	1	12	22.92	23.97	23.99	0	21.90	22.95	22.97	1
	1	24	23.12	23.99	24.02	0	22.10	22.97	23.00	1
	12	0	21.96	22.93	22.95	1	20.94	21.91	21.93	2
	12	6	21.93	22.87	22.83	1	20.91	21.85	21.81	2
	12	13	22.12	23.00	23.01	1	21.10	21.98	21.99	2
	25	0	22.00	22.96	22.99	1	20.98	21.94	21.97	2

Band / BW	RB Size	RB Offset	QPSK			3GPP MPR (dB)	16QAM			3GPP MPR (dB)
			Low Ch 20450	Mid Ch 20525	High Ch 20600		Low Ch 20450	Mid Ch 20525	High Ch 20600	
			829.0 MHz	836.5 MHz	844.0 MHz		829.0 MHz	836.5 MHz	844.0 MHz	
5 / 10M	1	0	22.79	23.47	23.50	0	21.79	22.46	22.56	1
	1	24	22.98	24.03	24.05	0	22.04	23.05	23.09	1
	1	49	23.18	24.05	24.08	0	22.26	23.08	23.10	1
	25	0	22.02	22.99	23.01	1	20.81	21.97	22.05	2
	25	12	21.99	22.93	22.89	1	20.78	21.90	21.92	2
	25	25	22.18	23.06	23.07	1	20.99	22.05	22.10	2
	50	0	22.06	23.02	23.05	1	21.09	22.00	22.09	2

Band / BW	RB Size	RB Offset	QPSK			3GPP MPR (dB)	16QAM			3GPP MPR (dB)
			Low Ch 26797	Mid Ch 26915	High Ch 27033		Low Ch 26797	Mid Ch 26915	High Ch 27033	
			824.7 MHz	836.5 MHz	848.3 MHz		824.7 MHz	836.5 MHz	848.3 MHz	
26 / 1.4M	1	0	22.83	22.94	23.32	0	21.82	21.93	22.33	1
	1	2	22.73	22.73	23.12	0	21.78	21.72	22.07	1
	1	5	23.42	23.49	23.81	0	22.38	22.54	22.80	1
	3	0	22.73	22.71	22.72	0	21.77	21.76	21.76	1
	3	1	22.71	22.73	22.71	0	21.73	21.71	21.75	1
	3	3	22.72	22.74	22.73	0	21.72	21.74	21.73	1
	6	0	21.72	21.84	22.21	1	20.72	20.76	21.24	2

Band / BW	RB Size	RB Offset	QPSK			3GPP MPR (dB)	16QAM			3GPP MPR (dB)
			Low Ch 26805	Mid Ch 26915	High Ch 27025		Low Ch 26805	Mid Ch 26915	High Ch 27025	
			825.5 MHz	836.5 MHz	847.5 MHz		825.5 MHz	836.5 MHz	847.5 MHz	
26 / 3M	1	0	22.89	23.00	23.39	0	21.91	22.02	22.44	1
	1	7	22.71	22.72	23.11	0	21.71	21.74	22.15	1
	1	14	23.35	23.54	23.86	0	22.39	22.59	22.91	1
	8	0	21.73	21.82	22.20	1	20.74	20.79	21.20	2
	8	3	21.71	21.72	21.97	1	20.72	20.73	20.96	2
	8	7	21.87	22.03	22.40	1	20.84	21.02	21.42	2
	15	0	21.82	21.91	22.22	1	20.79	20.89	21.23	2

Band / BW	RB Size	RB Offset	QPSK			3GPP MPR (dB)	16QAM			3GPP MPR (dB)
			Low Ch 26815	Mid Ch 26915	High Ch 27015		Low Ch 26815	Mid Ch 26915	High Ch 27015	
			826.5 MHz	836.5 MHz	846.5 MHz		826.5 MHz	836.5 MHz	846.5 MHz	
26 / 5M	1	0	22.97	23.08	23.45	0	22.00	22.12	22.50	1
	1	12	22.75	22.82	23.18	0	21.74	21.84	22.22	1
	1	24	23.41	23.59	23.91	0	22.45	22.64	22.96	1
	12	0	21.84	21.95	22.31	1	20.80	20.91	21.28	2
	12	6	21.71	21.77	22.09	1	20.71	20.73	21.06	2
	12	13	22.00	22.14	22.50	1	20.96	21.11	21.48	2
	25	0	21.95	22.03	22.33	1	20.91	21.00	21.31	2

Band / BW	RB Size	RB Offset	QPSK			3GPP MPR (dB)	16QAM			3GPP MPR (dB)
			Low Ch 26840	Mid Ch 26915	High Ch 26990		Low Ch 26840	Mid Ch 26915	High Ch 26990	
			829.0 MHz	836.5 MHz	844.0 MHz		829.0 MHz	836.5 MHz	844.0 MHz	
26 / 10M	1	0	23.07	23.17	23.52	0	22.08	22.19	22.55	1
	1	24	22.85	22.92	23.27	0	21.85	21.93	22.30	1
	1	49	23.49	23.65	23.96	0	22.52	22.69	23.00	1
	25	0	21.98	22.09	22.43	1	20.94	21.06	21.42	2
	25	12	21.84	21.92	22.22	1	20.79	20.88	21.21	2
	25	25	22.13	22.27	22.61	1	21.10	21.26	21.61	2
	50	0	22.09	22.16	22.45	1	21.06	21.13	21.44	2

Band / BW	RB Size	RB Offset	QPSK			3GPP MPR (dB)	16QAM			3GPP MPR (dB)
			Low Ch 26865	Mid Ch 26915	High Ch 26965		Low Ch 26865	Mid Ch 26915	High Ch 26965	
			831.5 MHz	836.5 MHz	841.5 MHz		831.5 MHz	836.5 MHz	841.5 MHz	
26 / 15M	1	0	23.15	23.25	23.58	0	22.19	22.29	22.62	1
	1	37	22.94	23.01	23.35	0	21.95	22.04	22.39	1
	1	74	23.56	23.71	24.01	0	22.60	22.76	23.06	1
	36	0	22.13	22.22	22.53	1	21.09	21.18	21.52	2
	36	19	21.99	22.07	22.34	1	20.94	21.03	21.32	2
	36	39	22.26	22.38	22.70	1	21.22	21.37	21.71	2
	75	0	22.22	22.29	22.55	1	21.18	21.26	21.55	2

ERP Power (dBm)

WCDMA							
Plane	Channel	Frequency (MHz)	LVL (dBm)	Correction Factor (dB)	ERP (dBm)	ERP (mW)	Polarization (H/V)
Y	4132	826.4	-5.62	31.208	23.44	220.70	H
	4182	836.4	-5.69	31.3	23.46	221.82	
	4233	846.6	-5.61	31.222	23.46	221.92	
	4132	826.4	-9.90	31.504	19.45	88.19	V
	4182	836.4	-9.62	31.117	19.35	86.04	
	4233	846.6	-10.36	31.922	19.41	87.34	

CDMA							
Plane	Channel	Frequency (MHz)	LVL (dBm)	Correction Factor (dB)	ERP (dBm)	ERP (mW)	Polarization (H/V)
Y	1013	824.7	-5.49	31.208	23.57	227.40	H
	384	836.52	-5.66	31.3	23.49	223.36	
	777	848.31	-5.57	31.222	23.50	223.98	
	1013	824.7	-9.71	31.504	19.64	92.13	V
	384	836.52	-9.42	31.117	19.55	90.09	
	777	848.31	-10.29	31.922	19.48	88.76	

LTE Band 5							
Channel Bandwidth: 1.4 MHz / QPSK							
Plane	Channel	Frequency (MHz)	LVL (dBm)	Correction Factor (dB)	ERP (dBm)	ERP (mW)	Polarization (H/V)
Y	20407	824.7	-5.64	31.208	23.42	219.68	H
	20525	836.5	-5.67	31.3	23.48	222.84	
	20643	848.3	-5.53	31.222	23.54	226.05	
	20407	824.7	-9.91	31.504	19.44	87.98	V
	20525	836.5	-9.56	31.117	19.41	87.24	
	20643	848.3	-10.29	31.922	19.48	88.76	
Channel Bandwidth: 1.4 MHz / 16QAM							
Y	20407	824.7	-6.65	31.208	22.41	174.10	H
	20525	836.5	-6.72	31.3	22.43	174.98	
	20643	848.3	-6.69	31.222	22.38	173.06	
	20407	824.7	-10.92	31.504	18.43	69.73	V
	20525	836.5	-10.67	31.117	18.30	67.56	
	20643	848.3	-11.53	31.922	18.24	66.71	

LTE Band 5							
Channel Bandwidth: 3 MHz / QPSK							
Plane	Channel	Frequency (MHz)	LVL (dBm)	Correction Factor (dB)	ERP (dBm)	ERP (mW)	Polarization (H/V)
Y	20415	825.5	-5.63	31.208	23.43	220.19	H
	20525	836.5	-5.70	31.3	23.45	221.31	
	20635	847.5	-5.63	31.222	23.44	220.90	
	20415	825.5	-9.96	31.504	19.39	86.98	V
	20525	836.5	-9.55	31.117	19.42	87.44	
	20635	847.5	-10.34	31.922	19.43	87.74	
Channel Bandwidth: 3 MHz / 16QAM							
Y	20415	825.5	-6.67	31.208	22.39	173.30	H
	20525	836.5	-6.80	31.3	22.35	171.79	
	20635	847.5	-6.69	31.222	22.38	173.06	
	20415	825.5	-10.96	31.504	18.39	69.09	V
	20525	836.5	-10.57	31.117	18.40	69.14	
	20635	847.5	-11.39	31.922	18.38	68.90	

LTE Band 5							
Channel Bandwidth: 5 MHz / QPSK							
Plane	Channel	Frequency (MHz)	LVL (dBm)	Correction Factor (dB)	ERP (dBm)	ERP (mW)	Polarization (H/V)
Y	20425	826.5	-5.68	31.208	23.38	217.67	H
	20525	836.5	-5.82	31.3	23.33	215.28	
	20625	846.5	-5.60	31.222	23.47	222.43	
	20425	826.5	-9.87	31.504	19.48	88.80	V
	20525	836.5	-9.60	31.117	19.37	86.44	
	20625	846.5	-10.22	31.922	19.55	90.20	
Channel Bandwidth: 5 MHz / 16QAM							
Y	20425	826.5	-6.58	31.208	22.48	176.93	H
	20525	836.5	-6.71	31.3	22.44	175.39	
	20625	846.5	-6.68	31.222	22.39	173.46	
	20425	826.5	-10.96	31.504	18.39	69.09	V
	20525	836.5	-10.67	31.117	18.30	67.56	
	20625	846.5	-11.33	31.922	18.44	69.86	

LTE Band 5							
Channel Bandwidth: 10 MHz / QPSK							
Plane	Channel	Frequency (MHz)	LVL (dBm)	Correction Factor (dB)	ERP (dBm)	ERP (mW)	Polarization (H/V)
Y	20450	829.0	-5.66	31.208	23.40	218.68	H
	20525	836.5	-5.62	31.3	23.53	225.42	
	20600	844.0	-5.60	31.222	23.47	222.43	
	20450	829.0	-9.88	31.504	19.47	88.59	V
	20525	836.5	-9.52	31.117	19.45	88.04	
	20600	844.0	-10.27	31.922	19.50	89.17	
Channel Bandwidth: 10 MHz / 16QAM							
Y	20450	829.0	-6.60	31.208	22.46	176.12	H
	20525	836.5	-6.82	31.3	22.33	171.00	
	20600	844.0	-6.71	31.222	22.36	172.27	
	20450	829.0	-10.88	31.504	18.47	70.37	V
	20525	836.5	-10.67	31.117	18.30	67.56	
	20600	844.0	-11.26	31.922	18.51	70.99	
LTE Band 26							
Channel Bandwidth: 1.4 MHz / QPSK							
Plane	Channel	Frequency (MHz)	LVL (dBm)	Correction Factor (dB)	ERP (dBm)	ERP (mW)	Polarization (H/V)
X	26797	824.7	-6.03	31.208	23.03	200.82	H
	26915	836.5	-6.06	31.3	23.09	203.70	
	27033	848.3	-5.97	31.222	23.10	204.27	
	26797	824.7	-10.33	31.504	19.02	79.87	V
	26915	836.5	-9.97	31.117	19.00	79.38	
	27033	848.3	-10.70	31.922	19.07	80.76	
Channel Bandwidth: 1.4 MHz / 16QAM							
X	26797	824.7	-7.06	31.208	22.00	158.42	H
	26915	836.5	-7.11	31.3	22.04	159.96	
	27033	848.3	-6.99	31.222	22.08	161.51	
	26797	824.7	-11.30	31.504	18.05	63.89	V
	26915	836.5	-10.89	31.117	18.08	64.22	
	27033	848.3	-11.67	31.922	18.10	64.60	

LTE Band 26							
Channel Bandwidth: 3 MHz / QPSK							
Plane	Channel	Frequency (MHz)	LVL (dBm)	Correction Factor (dB)	ERP (dBm)	ERP (mW)	Polarization (H/V)
X	26805	825.5	-5.99	31.208	23.07	202.67	H
	26915	836.5	-6.08	31.3	23.07	202.77	
	27025	847.5	-6.03	31.222	23.04	201.47	
	26805	825.5	-10.32	31.504	19.03	80.06	V
	26915	836.5	-9.92	31.117	19.05	80.30	
	27025	847.5	-10.75	31.922	19.02	79.84	
Channel Bandwidth: 3 MHz / 16QAM							
X	26805	825.5	-7.02	31.208	22.04	159.88	H
	26915	836.5	-7.12	31.3	22.03	159.59	
	27025	847.5	-7.00	31.222	22.07	161.14	
	26805	825.5	-11.30	31.504	18.05	63.89	V
	26915	836.5	-10.92	31.117	18.05	63.78	
	27025	847.5	-11.70	31.922	18.07	64.15	

LTE Band 26							
Channel Bandwidth: 5 MHz / QPSK							
Plane	Channel	Frequency (MHz)	LVL (dBm)	Correction Factor (dB)	ERP (dBm)	ERP (mW)	Polarization (H/V)
X	26815	826.5	-6.05	31.208	23.01	199.89	H
	26915	836.5	-6.12	31.3	23.03	200.91	
	27015	846.5	-6.06	31.222	23.01	200.08	
	26815	826.5	-10.29	31.504	19.06	80.61	V
	26919	836.5	-9.93	31.117	19.04	80.11	
	27015	846.5	-10.69	31.922	19.08	80.95	
Channel Bandwidth: 5 MHz / 16QAM							
X	26815	826.5	-7.00	31.208	22.06	160.62	H
	26915	836.5	-7.10	31.3	22.05	160.32	
	27015	846.5	-6.97	31.222	22.10	162.26	
	26815	826.5	-11.30	31.504	18.05	63.89	V
	26919	836.5	-10.90	31.117	18.07	64.08	
	27015	846.5	-11.71	31.922	18.06	64.00	

LTE Band 26							
Channel Bandwidth: 10 MHz / QPSK							
Plane	Channel	Frequency (MHz)	LVL (dBm)	Correction Factor (dB)	ERP (dBm)	ERP (mW)	Polarization (H/V)
X	26840	829.0	-6.02	31.208	23.04	201.28	H
	26915	836.5	-6.08	31.3	23.07	202.77	
	26990	844.0	-6.06	31.222	23.01	200.08	
	26840	829.0	-10.33	31.504	19.02	79.87	V
	26919	836.5	-9.92	31.117	19.05	80.30	
	26990	844.0	-10.70	31.922	19.07	80.76	
Channel Bandwidth: 10 MHz / 16QAM							
X	26840	829.0	-6.96	31.208	22.10	162.11	H
	26915	836.5	-7.10	31.3	22.05	160.32	
	26990	844.0	-6.92	31.222	22.15	164.13	
	26840	829.0	-11.26	31.504	18.09	64.48	V
	26919	836.5	-10.95	31.117	18.02	63.34	
	26990	844.0	-11.69	31.922	18.08	64.30	

LTE Band 26							
Channel Bandwidth: 15 MHz / QPSK							
Plane	Channel	Frequency (MHz)	LVL (dBm)	Correction Factor (dB)	ERP (dBm)	ERP (mW)	Polarization (H/V)
X	26865	831.5	-6.05	31.208	23.01	199.89	H
	26915	836.5	-6.09	31.3	23.06	202.30	
	26965	841.5	-6.02	31.222	23.05	201.93	
	26865	831.5	-10.30	31.504	19.05	80.43	V
	26915	836.5	-9.90	31.117	19.07	80.67	
	26965	841.5	-10.69	31.922	19.08	80.95	
Channel Bandwidth: 15 MHz / 16QAM							
X	26865	831.5	-7.05	31.208	22.01	158.78	H
	26915	836.5	-7.12	31.3	22.03	159.59	
	26965	841.5	-7.04	31.222	22.03	159.66	
	26865	831.5	-11.26	31.504	18.09	64.48	V
	26915	836.5	-10.96	31.117	18.01	63.20	
	26965	841.5	-11.71	31.922	18.06	64.00	

4.2 Frequency Stability Measurement

4.2.1 Limits of Frequency Stability Measurement

1.5 ppm is for base and fixed station. 2.5 ppm is for mobile station.

4.2.2 Test Procedure

- Device is placed at the oven room. The oven room could control the temperatures and humidity. Power warm up is at least 15 min and power applied should perform before recording frequency error.
- EUT is connected the external power supply to control the DC input power. The test voltage range is from minimum to maximum working voltage. Each step shall be record the frequency error rate.
- The temperature range step is 10 degrees in this test items. All temperature levels shall be hold the ± 0.5 °C during the measurement testing. The each temperature step shall be at least 0.5 hours, consider the EUT could be test under the stability condition.

NOTE: The frequency error was recorded frequency error from the communication simulator.

4.2.3 Test Setup

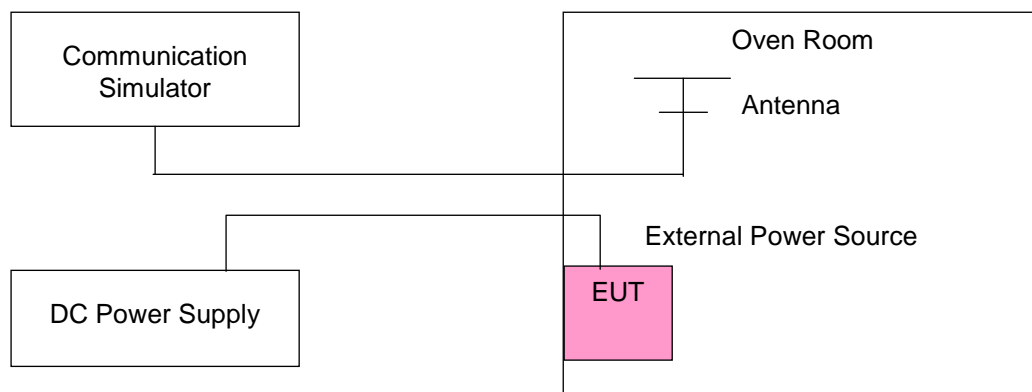

4.2.4 Test Results

Frequency Error vs. Voltage

Voltage (Volts)	WCDMA				Limit (ppm)
	Low Channel		High Channel		
	Frequency (MHz)	Frequency Error (ppm)	Frequency (MHz)	Frequency Error (ppm)	
3.8	826.400002	0.002	846.600003	0.003	2.5
3.3	826.400002	0.003	846.600002	0.002	2.5
4.35	826.400002	0.002	846.600003	0.003	2.5

Note: The applicant defined the normal working voltage of the battery is from 3.3 Vdc to 4.35 Vdc.

Frequency Error vs. Temperature

Temp. (°C)	WCDMA				Limit (ppm)
	Low Channel		High Channel		
	Frequency (MHz)	Frequency Error (ppm)	Frequency (MHz)	Frequency Error (ppm)	
-30	826.400002	0.003	846.600004	0.004	2.5
-20	826.400004	0.004	846.600002	0.002	2.5
-10	826.400001	0.002	846.600002	0.003	2.5
0	826.400001	0.002	846.600001	0.002	2.5
10	826.400002	0.002	846.600001	0.001	2.5
20	826.399999	-0.002	846.599998	-0.003	2.5
30	826.399999	-0.002	846.599997	-0.003	2.5
40	826.399998	-0.003	846.599998	-0.002	2.5
50	826.399997	-0.003	846.599998	-0.002	2.5
60	826.399998	-0.002	846.599997	-0.003	2.5

Frequency Error vs. Voltage

Voltage (Volts)	CDMA				Limit (ppm)
	Low Channel		High Channel		
	Frequency (MHz)	Frequency Error (ppm)	Frequency (MHz)	Frequency Error (ppm)	
3.8	824.700002	0.003	848.310003	0.003	2.5
3.3	824.700002	0.002	848.310003	0.004	2.5
4.35	824.700002	0.003	848.310004	0.005	2.5

Note: The applicant defined the normal working voltage of the battery is from 3.3 Vdc to 4.35 Vdc.

Frequency Error vs. Temperature

Temp. (°C)	CDMA				Limit (ppm)
	Low Channel		High Channel		
	Frequency (MHz)	Frequency Error (ppm)	Frequency (MHz)	Frequency Error (ppm)	
-30	824.700004	0.005	848.310002	0.003	2.5
-20	824.700002	0.003	848.310003	0.004	2.5
-10	824.700002	0.003	848.310001	0.001	2.5
0	824.700001	0.001	848.310002	0.002	2.5
10	824.700002	0.003	848.310001	0.002	2.5
20	824.699998	-0.003	848.309996	-0.004	2.5
30	824.699996	-0.005	848.309997	-0.004	2.5
40	824.699997	-0.004	848.309999	-0.001	2.5
50	824.699997	-0.003	848.309997	-0.004	2.5
60	824.699998	-0.002	848.309998	-0.002	2.5

Frequency Error vs. Voltage

Voltage (Volts)	LTE Band 5				Limit (ppm)
	Channel Bandwidth: 1.4 MHz				
	Low Channel		High Channel		
	Frequency (MHz)	Frequency Error (ppm)	Frequency (MHz)	Frequency Error (ppm)	
3.8	824.700003	0.004	848.300003	0.004	2.5
3.3	824.700003	0.003	848.300002	0.002	2.5
4.35	824.700003	0.003	848.300003	0.003	2.5

Note: The applicant defined the normal working voltage of the battery is from 3.3 Vdc to 4.35 Vdc.

Frequency Error vs. Temperature

Temp. (°C)	LTE Band 5				Limit (ppm)
	Channel Bandwidth: 1.4 MHz				
	Low Channel		High Channel		
	Frequency (MHz)	Frequency Error (ppm)	Frequency (MHz)	Frequency Error (ppm)	
-30	824.700003	0.004	848.300002	0.002	2.5
-20	824.700003	0.003	848.300003	0.003	2.5
-10	824.700002	0.003	848.300003	0.004	2.5
0	824.700002	0.002	848.300004	0.004	2.5
10	824.700004	0.004	848.300001	0.001	2.5
20	824.699998	-0.002	848.299998	-0.003	2.5
30	824.699999	-0.001	848.299996	-0.005	2.5
40	824.699999	-0.002	848.299998	-0.003	2.5
50	824.699997	-0.004	848.299999	-0.002	2.5
60	824.699997	-0.003	848.299999	-0.002	2.5

Frequency Error vs. Voltage

Voltage (Volts)	LTE Band 5				Limit (ppm)
	Channel Bandwidth: 3 MHz				
	Low Channel		High Channel		
	Frequency (MHz)	Frequency Error (ppm)	Frequency (MHz)	Frequency Error (ppm)	
3.8	825.500004	0.005	847.500001	0.001	2.5
3.3	825.500004	0.004	847.500003	0.003	2.5
4.35	825.500004	0.004	847.500001	0.002	2.5

Note: The applicant defined the normal working voltage of the battery is from 3.3 Vdc to 4.35 Vdc.

Frequency Error vs. Temperature

Temp. (°C)	LTE Band 5				Limit (ppm)
	Channel Bandwidth: 3 MHz				
	Low Channel		High Channel		
	Frequency (MHz)	Frequency Error (ppm)	Frequency (MHz)	Frequency Error (ppm)	
-30	825.500003	0.004	847.500001	0.001	2.5
-20	825.500002	0.002	847.500003	0.003	2.5
-10	825.500002	0.003	847.500002	0.003	2.5
0	825.500004	0.005	847.500001	0.001	2.5
10	825.500002	0.002	847.500003	0.003	2.5
20	825.499999	-0.001	847.499997	-0.003	2.5
30	825.499999	-0.002	847.499996	-0.004	2.5
40	825.499999	-0.002	847.499997	-0.004	2.5
50	825.499998	-0.002	847.499997	-0.004	2.5
60	825.499999	-0.001	847.499996	-0.004	2.5

Frequency Error vs. Voltage

Voltage (Volts)	LTE Band 5				Limit (ppm)
	Channel Bandwidth: 5 MHz				
	Low Channel		High Channel		
	Frequency (MHz)	Frequency Error (ppm)	Frequency (MHz)	Frequency Error (ppm)	
3.8	826.500002	0.003	846.500003	0.004	2.5
3.3	826.500004	0.004	846.500004	0.004	2.5
4.35	826.500001	0.001	846.500002	0.002	2.5

Note: The applicant defined the normal working voltage of the battery is from 3.3 Vdc to 4.35 Vdc.

Frequency Error vs. Temperature

Temp. (°C)	LTE Band 5				Limit (ppm)
	Channel Bandwidth: 5 MHz				
	Low Channel		High Channel		
	Frequency (MHz)	Frequency Error (ppm)	Frequency (MHz)	Frequency Error (ppm)	
-30	826.500001	0.002	846.500004	0.004	2.5
-20	826.500002	0.002	846.500001	0.001	2.5
-10	826.500002	0.003	846.500003	0.003	2.5
0	826.500004	0.004	846.500003	0.004	2.5
10	826.500003	0.004	846.500003	0.004	2.5
20	826.499997	-0.004	846.499999	-0.001	2.5
30	826.499996	-0.005	846.499998	-0.002	2.5
40	826.499998	-0.003	846.499999	-0.002	2.5
50	826.499997	-0.004	846.499998	-0.002	2.5
60	826.499999	-0.002	846.499999	-0.001	2.5

Frequency Error vs. Voltage

Voltage (Volts)	LTE Band 5				Limit (ppm)
	Channel Bandwidth: 10 MHz				
	Low Channel		High Channel		
	Frequency (MHz)	Frequency Error (ppm)	Frequency (MHz)	Frequency Error (ppm)	
3.8	829.000004	0.004	844.000001	0.001	2.5
3.3	829.000004	0.004	844.000003	0.003	2.5
4.35	829.000003	0.003	844.000001	0.001	2.5

Note: The applicant defined the normal working voltage of the battery is from 3.3 Vdc to 4.35 Vdc.

Frequency Error vs. Temperature

Temp. (°C)	LTE Band 5				Limit (ppm)
	Channel Bandwidth: 10 MHz				
	Low Channel		High Channel		
	Frequency (MHz)	Frequency Error (ppm)	Frequency (MHz)	Frequency Error (ppm)	
-30	829.000001	0.001	844.000003	0.003	2.5
-20	829.000003	0.004	844.000002	0.003	2.5
-10	829.000002	0.002	844.000003	0.004	2.5
0	829.000003	0.004	844.000003	0.003	2.5
10	829.000002	0.002	844.000003	0.004	2.5
20	828.999998	-0.003	843.999997	-0.004	2.5
30	828.999997	-0.004	843.999996	-0.004	2.5
40	828.999998	-0.003	843.999996	-0.004	2.5
50	828.999997	-0.004	843.999996	-0.005	2.5
60	828.999998	-0.002	843.999999	-0.001	2.5

Frequency Error vs. Voltage

Voltage (Volts)	LTE Band 26				Limit (ppm)
	Channel Bandwidth: 1.4 MHz				
	Low Channel		High Channel		
	Frequency (MHz)	Frequency Error (ppm)	Frequency (MHz)	Frequency Error (ppm)	
3.8	824.700002	0.002	848.300002	0.002	2.5
3.3	824.700004	0.004	848.300002	0.003	2.5
4.35	824.700004	0.005	848.300003	0.004	2.5

Note: The applicant defined the normal working voltage of the battery is from 3.3 Vdc to 4.35 Vdc.

Frequency Error vs. Temperature

Temp. (°C)	LTE Band 26				Limit (ppm)
	Channel Bandwidth: 1.4 MHz				
	Low Channel		High Channel		
	Frequency (MHz)	Frequency Error (ppm)	Frequency (MHz)	Frequency Error (ppm)	
-30	824.700002	0.003	848.300003	0.003	2.5
-20	824.700004	0.004	848.300003	0.003	2.5
-10	824.700001	0.001	848.300003	0.004	2.5
0	824.700002	0.002	848.300003	0.003	2.5
10	824.700002	0.002	848.300002	0.002	2.5
20	824.699999	-0.002	848.299999	-0.002	2.5
30	824.699999	-0.002	848.299997	-0.004	2.5
40	824.699998	-0.003	848.299999	-0.002	2.5
50	824.699997	-0.003	848.299997	-0.004	2.5
60	824.699998	-0.002	848.299999	-0.001	2.5

Frequency Error vs. Voltage

Voltage (Volts)	LTE Band 26				Limit (ppm)
	Channel Bandwidth: 3 MHz				
	Low Channel		High Channel		
	Frequency (MHz)	Frequency Error (ppm)	Frequency (MHz)	Frequency Error (ppm)	
3.8	825.500004	0.004	847.500003	0.003	2.5
3.3	825.500003	0.004	847.500003	0.004	2.5
4.35	825.500003	0.004	847.500004	0.004	2.5

Note: The applicant defined the normal working voltage of the battery is from 3.3 Vdc to 4.35 Vdc.

Frequency Error vs. Temperature

Temp. (°C)	LTE Band 26				Limit (ppm)
	Channel Bandwidth: 3 MHz				
	Low Channel		High Channel		
	Frequency (MHz)	Frequency Error (ppm)	Frequency (MHz)	Frequency Error (ppm)	
-30	825.500003	0.003	847.500002	0.002	2.5
-20	825.500002	0.002	847.500003	0.004	2.5
-10	825.500003	0.004	847.500002	0.003	2.5
0	825.500002	0.002	847.500002	0.003	2.5
10	825.500003	0.004	847.500001	0.001	2.5
20	825.499996	-0.005	847.499998	-0.003	2.5
30	825.499996	-0.004	847.499998	-0.002	2.5
40	825.499997	-0.004	847.499999	-0.002	2.5
50	825.499998	-0.003	847.499998	-0.002	2.5
60	825.499996	-0.004	847.499999	-0.001	2.5

Frequency Error vs. Voltage

Voltage (Volts)	LTE Band 26				Limit (ppm)
	Channel Bandwidth: 5 MHz				
	Low Channel		High Channel		
	Frequency (MHz)	Frequency Error (ppm)	Frequency (MHz)	Frequency Error (ppm)	
3.8	826.500003	0.003	846.500002	0.003	2.5
3.3	826.500002	0.002	846.500003	0.004	2.5
4.35	826.500001	0.001	846.500004	0.005	2.5

Note: The applicant defined the normal working voltage of the battery is from 3.3 Vdc to 4.35 Vdc.

Frequency Error vs. Temperature

Temp. (°C)	LTE Band 26				Limit (ppm)
	Channel Bandwidth: 5 MHz				
	Low Channel		High Channel		
	Frequency (MHz)	Frequency Error (ppm)	Frequency (MHz)	Frequency Error (ppm)	
-30	826.500004	0.004	846.500001	0.002	2.5
-20	826.500001	0.001	846.500002	0.002	2.5
-10	826.500004	0.005	846.500004	0.004	2.5
0	826.500003	0.003	846.500002	0.002	2.5
10	826.500003	0.003	846.500002	0.002	2.5
20	826.499998	-0.003	846.499997	-0.003	2.5
30	826.499998	-0.002	846.499998	-0.002	2.5
40	826.499998	-0.002	846.499998	-0.002	2.5
50	826.499999	-0.002	846.499996	-0.004	2.5
60	826.499996	-0.005	846.499997	-0.003	2.5

Frequency Error vs. Voltage

Voltage (Volts)	LTE Band 26				Limit (ppm)
	Channel Bandwidth: 10 MHz				
	Low Channel		High Channel		
	Frequency (MHz)	Frequency Error (ppm)	Frequency (MHz)	Frequency Error (ppm)	
3.8	829.000003	0.003	844.000001	0.001	2.5
3.3	829.000004	0.005	844.000002	0.002	2.5
4.35	829.000004	0.004	844.000001	0.001	2.5

Note: The applicant defined the normal working voltage of the battery is from 3.3 Vdc to 4.35 Vdc.

Frequency Error vs. Temperature

Temp. (°C)	LTE Band 26				Limit (ppm)
	Channel Bandwidth: 10 MHz				
	Low Channel		High Channel		
	Frequency (MHz)	Frequency Error (ppm)	Frequency (MHz)	Frequency Error (ppm)	
-30	829.000003	0.003	844.000001	0.001	2.5
-20	829.000001	0.002	844.000003	0.004	2.5
-10	829.000002	0.002	844.000003	0.004	2.5
0	829.000003	0.003	844.000004	0.004	2.5
10	829.000001	0.002	844.000002	0.003	2.5
20	828.999999	-0.002	843.999997	-0.003	2.5
30	828.999999	-0.001	843.999997	-0.004	2.5
40	828.999998	-0.002	843.999997	-0.003	2.5
50	828.999997	-0.004	843.999996	-0.004	2.5
60	828.999996	-0.004	843.999996	-0.005	2.5

Frequency Error vs. Voltage

Voltage (Volts)	LTE Band 26				Limit (ppm)
	Channel Bandwidth: 15 MHz				
	Low Channel		High Channel		
	Frequency (MHz)	Frequency Error (ppm)	Frequency (MHz)	Frequency Error (ppm)	
3.8	831.500003	0.003	841.500003	0.003	2.5
3.3	831.500002	0.003	841.500002	0.002	2.5
4.35	831.500004	0.005	841.500002	0.002	2.5

Note: The applicant defined the normal working voltage of the battery is from 3.3 Vdc to 4.35 Vdc.

Frequency Error vs. Temperature

Temp. (°C)	LTE Band 26				Limit (ppm)
	Channel Bandwidth: 15 MHz				
	Low Channel		High Channel		
	Frequency (MHz)	Frequency Error (ppm)	Frequency (MHz)	Frequency Error (ppm)	
-30	831.500004	0.004	841.500004	0.004	2.5
-20	831.500001	0.002	841.500002	0.003	2.5
-10	831.500003	0.004	841.500004	0.004	2.5
0	831.500001	0.002	841.500002	0.002	2.5
10	831.500001	0.001	841.500003	0.003	2.5
20	831.499998	-0.002	841.499997	-0.003	2.5
30	831.499997	-0.004	841.499997	-0.004	2.5
40	831.499998	-0.003	841.499998	-0.003	2.5
50	831.499996	-0.005	841.499999	-0.002	2.5
60	831.499997	-0.003	841.499998	-0.003	2.5

4.3 Occupied Bandwidth Measurement

4.3.1 Test Procedure

The EUT makes a call to the communication simulator. All measurements were done at low, middle and high operational frequency range. The communication simulator station system controlled a EUT to export maximum output power under transmission mode and specific channel frequency. Use OBW measurement function of Spectrum analyzer to measure 99 % occupied bandwidth.

4.3.2 Test Setup

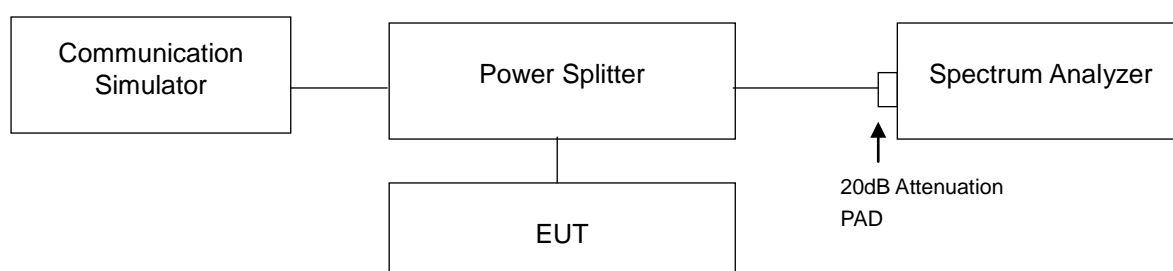

4.3.3 Test Result

Channel	Frequency (MHz)	99 % Occupied Bandwidth (kHz)	Channel	Frequency (MHz)	99 % Occupied Bandwidth (MHz)
		WCDMA			CDMA
4132	826.4	4.1547	1013	824.70	1.2744
4182	836.4	4.1644	384	836.52	1.2736
4233	846.6	4.1652	777	848.31	1.2767

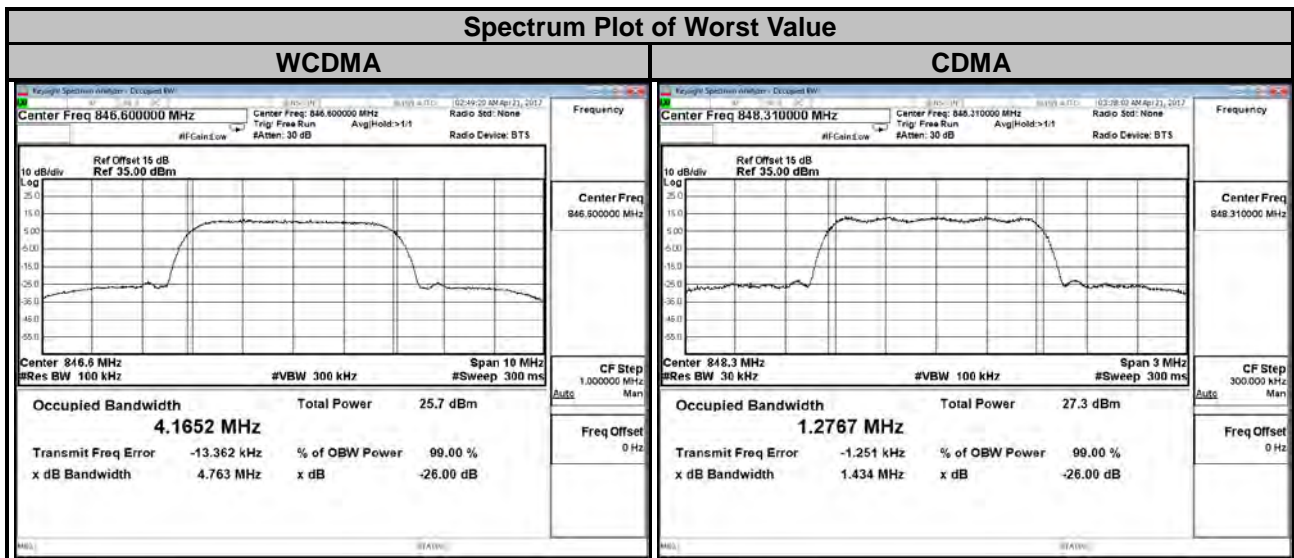

LTE Band 5

Channel Bandwidth: 1.4 MHz

Channel Bandwidth: 3 MHz

Channel	Frequency (MHz)	99 % Occupied Bandwidth (MHz)		Channel	Frequency (MHz)	99 % Occupied Bandwidth (MHz)	
		QPSK	16QAM			QPSK	16QAM
20407	824.7	1.0890	1.0878	20415	825.5	2.7017	2.6974
20525	836.5	1.0877	1.0888	20525	836.5	2.7024	2.6969
20643	848.3	1.0872	1.0881	20635	847.5	2.7022	2.6978

Spectrum Plot of Worst Value

1.4 MHz / QPSK

1.4 MHz / 16QAM

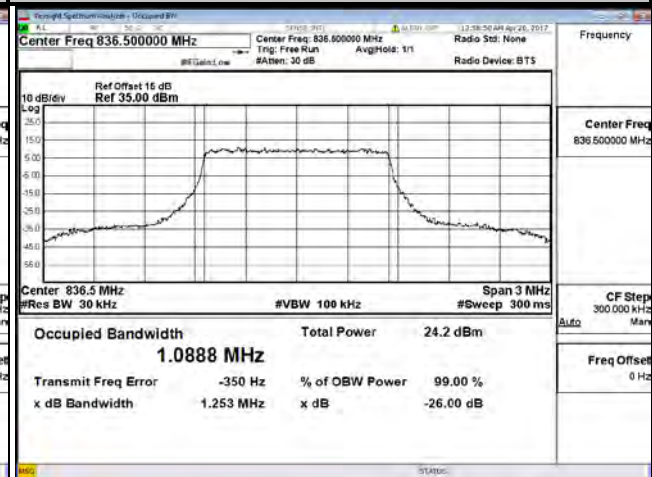
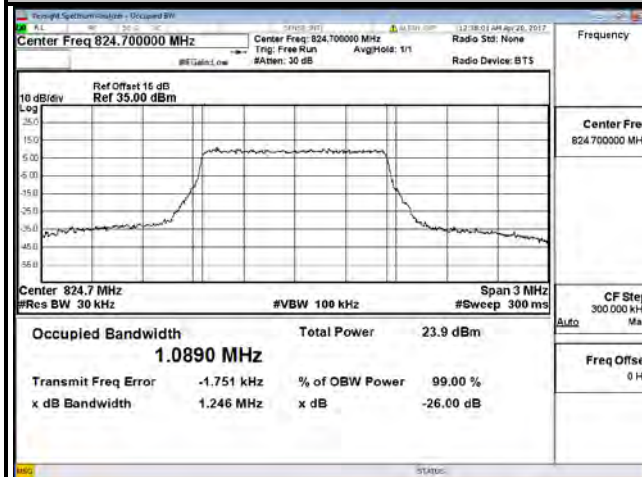

3 MHz / QPSK

3 MHz / 16QAM

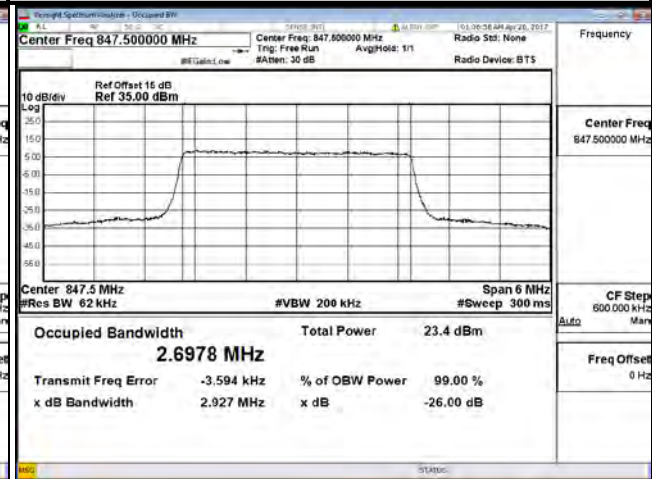
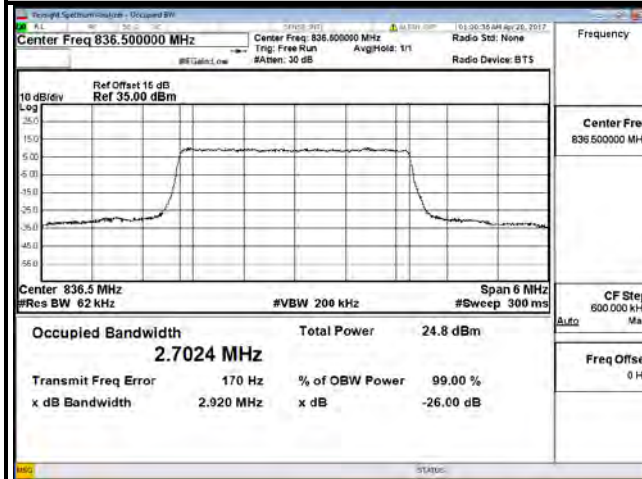

LTE Band 5							
Channel Bandwidth: 5 MHz				Channel Bandwidth: 10 MHz			
Channel	Frequency (MHz)	99 % Occupied Bandwidth (MHz)		Channel	Frequency (MHz)	99 % Occupied Bandwidth (MHz)	
		QPSK	16QAM			QPSK	16QAM
20425	826.5	4.4941	4.4943	20450	829.0	8.9567	8.9590
20525	836.5	4.4932	4.4940	20525	836.5	8.9644	8.9613
20625	846.5	4.4938	4.4918	20600	844.0	8.9430	8.9455

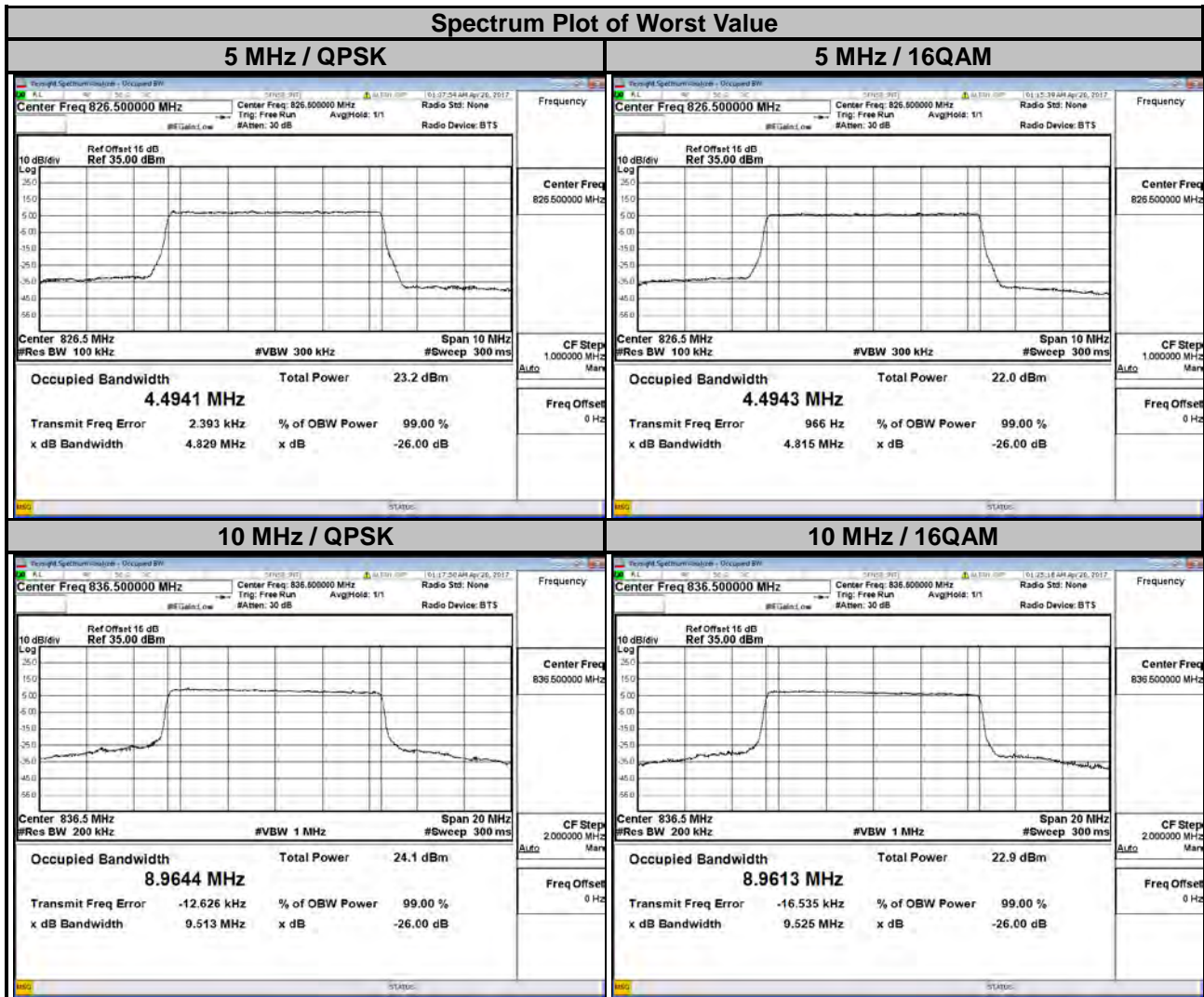

LTE Band 26

Channel Bandwidth: 1.4 MHz				Channel Bandwidth: 3 MHz			
Channel	Frequency (MHz)	99 % Occupied Bandwidth (MHz)		Channel	Frequency (MHz)	99 % Occupied Bandwidth (MHz)	
		QPSK	16QAM			QPSK	16QAM
26797	824.7	1.0888	1.0885	26805	825.5	2.7033	2.6998
26915	836.5	1.0874	1.0892	26915	836.5	2.7033	2.6972
27033	848.3	1.0891	1.0893	27025	847.5	2.7035	2.6976

Spectrum Plot of Worst Value

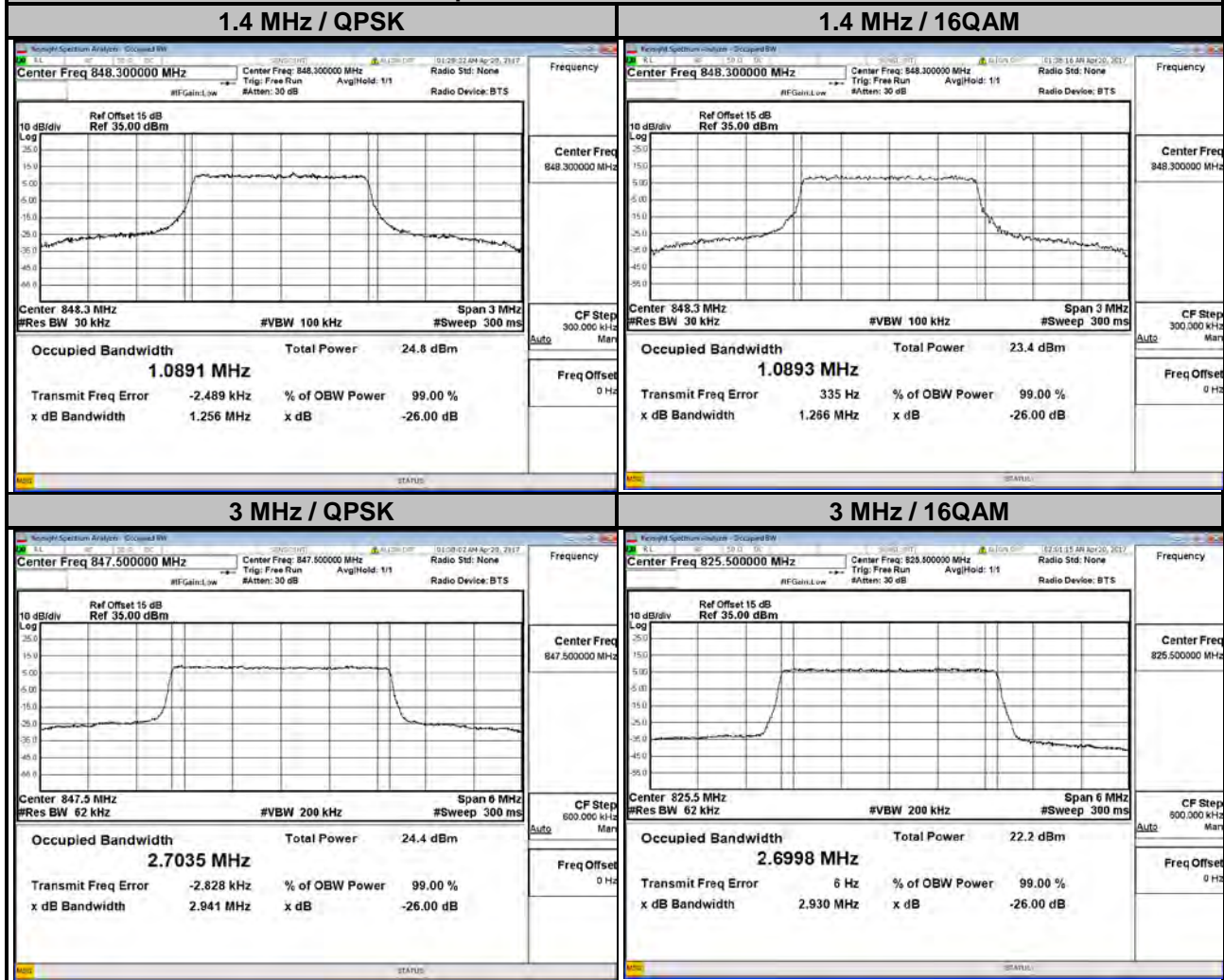

LTE Band 26

Channel Bandwidth: 5 MHz				Channel Bandwidth: 10 MHz			
Channel	Frequency (MHz)	99 % Occupied Bandwidth (MHz)		Channel	Frequency (MHz)	99 % Occupied Bandwidth (MHz)	
		QPSK	16QAM			QPSK	16QAM
26815	826.5	4.4954	4.4961	26840	829.0	8.9556	8.9609
26915	836.5	4.4954	4.4969	26915	836.5	8.9655	8.9662
27015	846.5	4.4927	4.4930	26990	844.0	8.9451	8.9561

Spectrum Plot of Worst Value

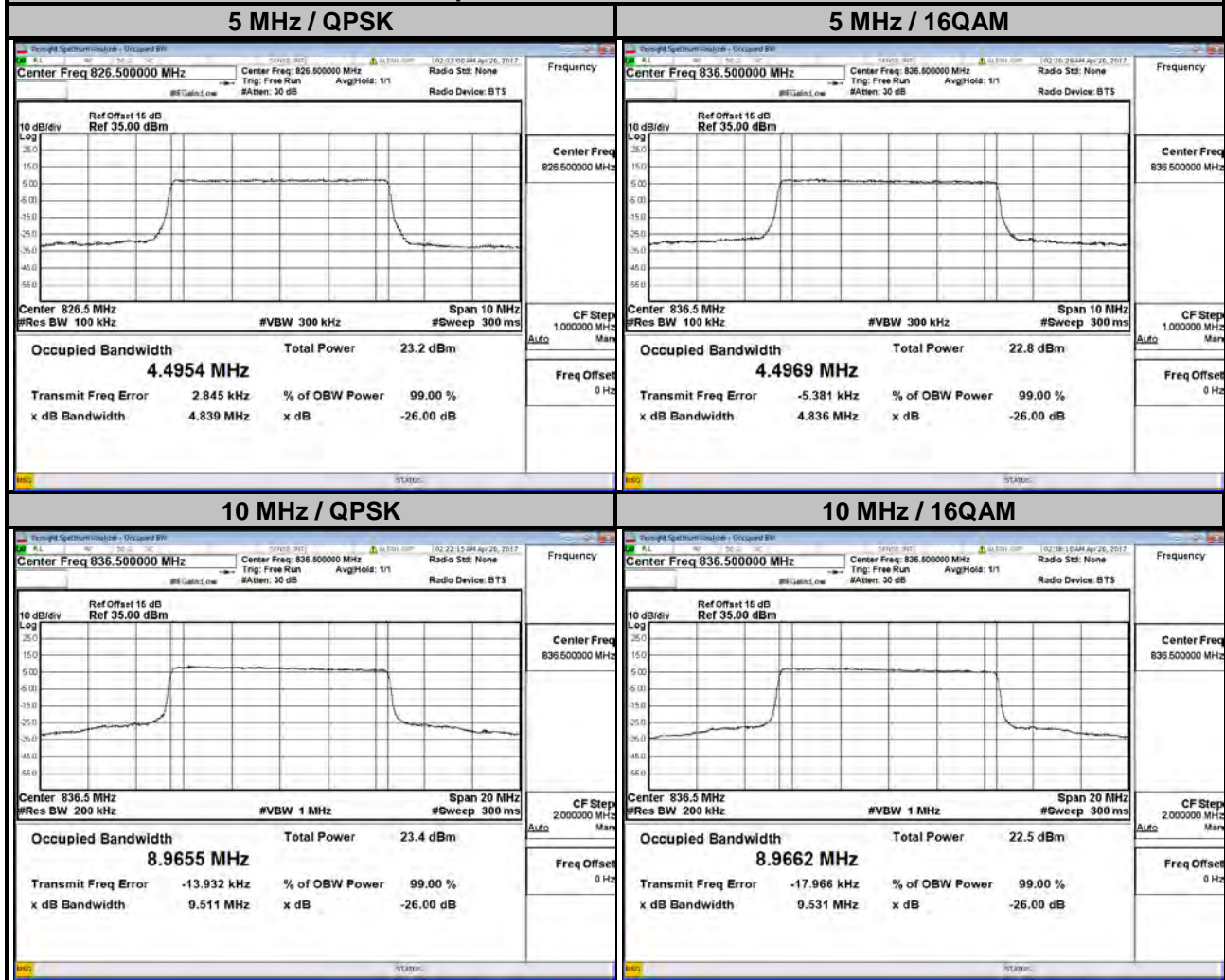

LTE Band 26

Channel Bandwidth: 15 MHz

Channel	Frequency (MHz)	99 % Occupied Bandwidth (MHz)	
		QPSK	16QAM
26865	831.5	13.4320	13.4200
26915	836.5	13.4720	13.4590
26965	841.5	13.4570	13.4470

Spectrum Plot of Worst Value

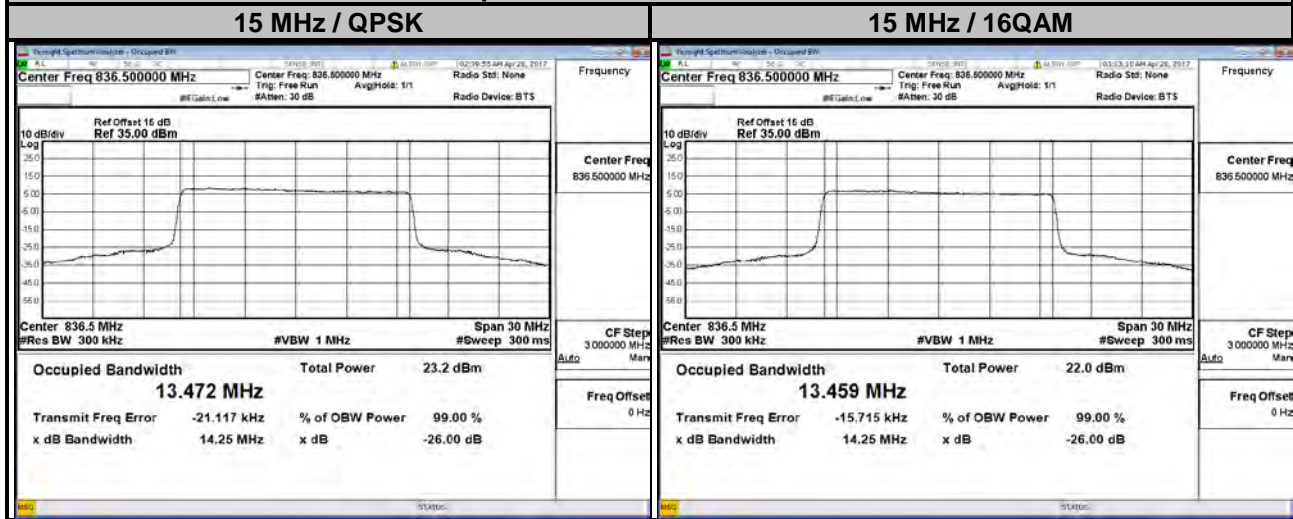

4.4 Band Edge Measurement

4.4.1 Limits of Band Edge Measurement

Power of any emission outside of the authorized operating frequency ranges must be attenuated below the transmitting power (P) by a factor of at least $43 + 10 \log(P)$ dB. In the 1 MHz bands immediately outside and adjacent to the frequency block a resolution bandwidth of at least one percent of the emission bandwidth of the fundamental emission of the transmitter may be employed.

4.4.2 Test Setup

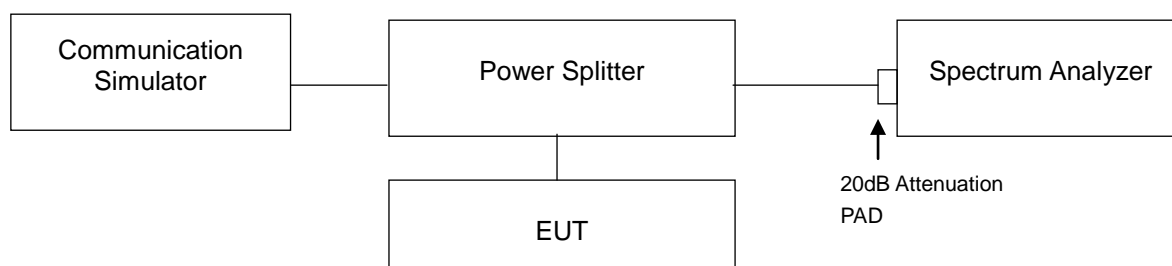

4.4.3 Test Procedures

- a. All measurements were done at low and high operational frequency range.
- b. The center frequency of spectrum is the band edge frequency and span is 5 MHz. RB of the spectrum is 100 kHz and VB of the spectrum is 300 kHz (WCDMA).
- c. The center frequency of spectrum is the band edge frequency and span is 1 MHz. RB of the spectrum is 13 kHz and VB of the spectrum is 51 kHz (CDMA / LTE Bandwidth 1.4 MHz).
- d. The center frequency of spectrum is the band edge frequency and span is 1 MHz. RB of the spectrum is 30 kHz and VB of the spectrum is 100 kHz (LTE Bandwidth 3 MHz).
- e. The center frequency of spectrum is the band edge frequency and span is 1 MHz. RB of the spectrum is 100 kHz and VB of the spectrum is 300 kHz (LTE Bandwidth 5 MHz/10 MHz).
- f. The center frequency of spectrum is the band edge frequency and span is 1MHz. RB of the spectrum is 150 kHz and VB of the spectrum is 470 kHz (LTE Bandwidth 15 MHz).
- g. Record the max trace plot into the test report.

4.4.4 Test Results

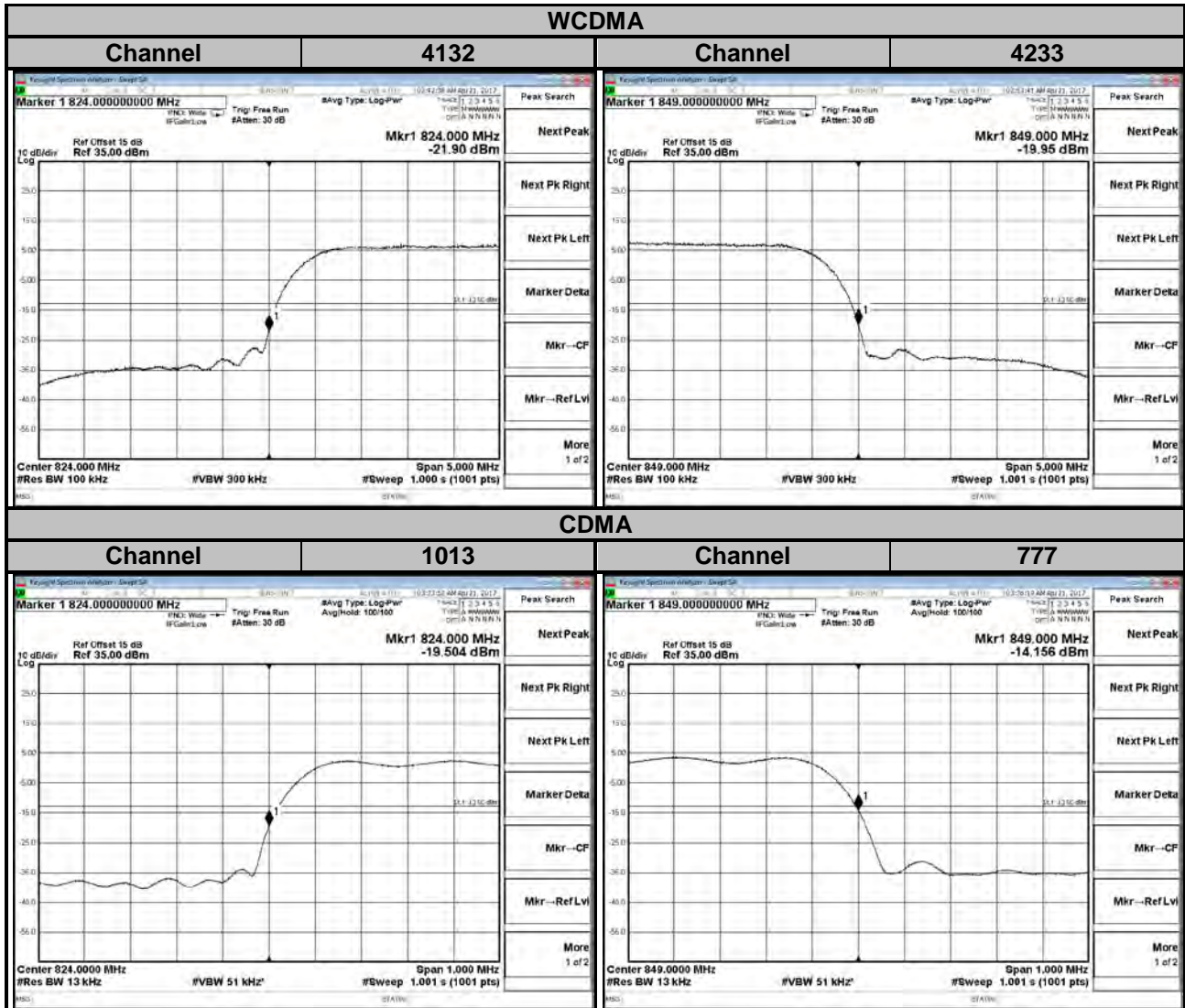

LTE Band 5

Channel Bandwidth: 1.4 MHz

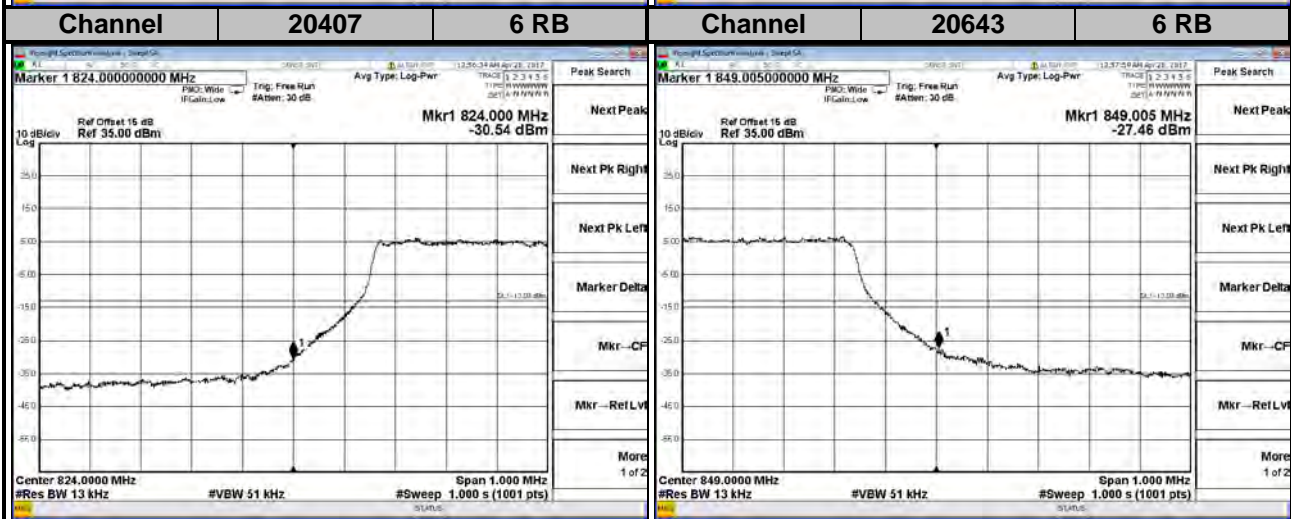
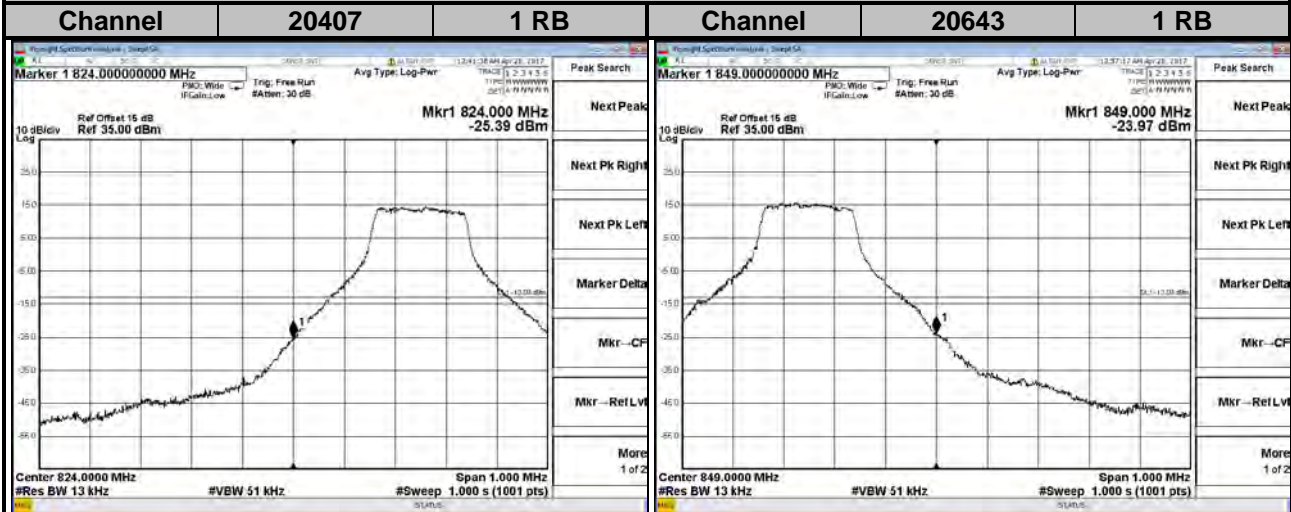

LTE Band 5

Channel Bandwidth: 3 MHz

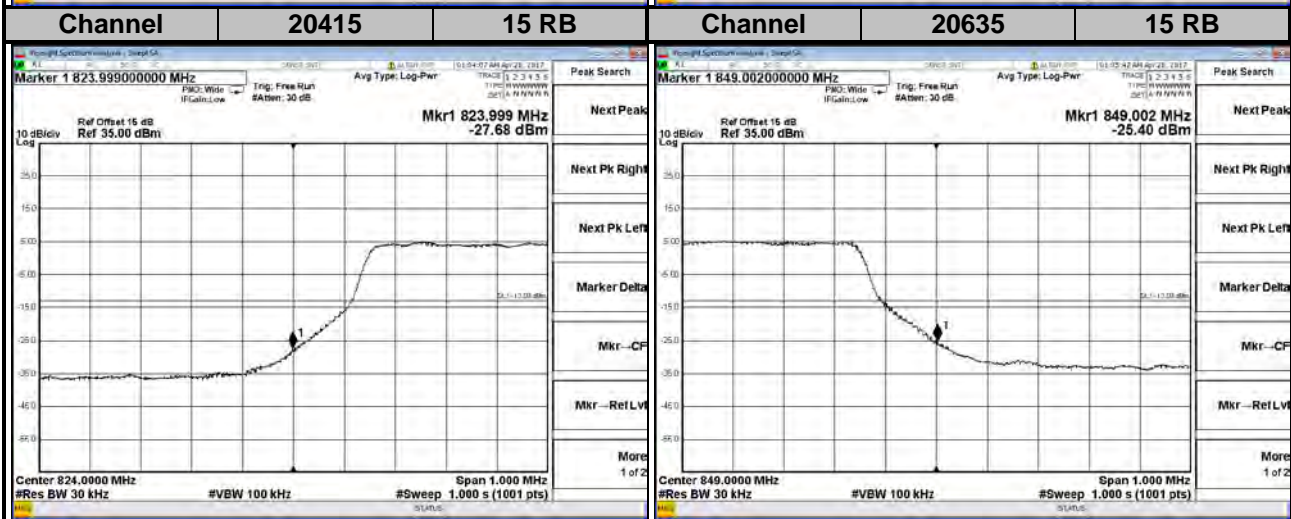
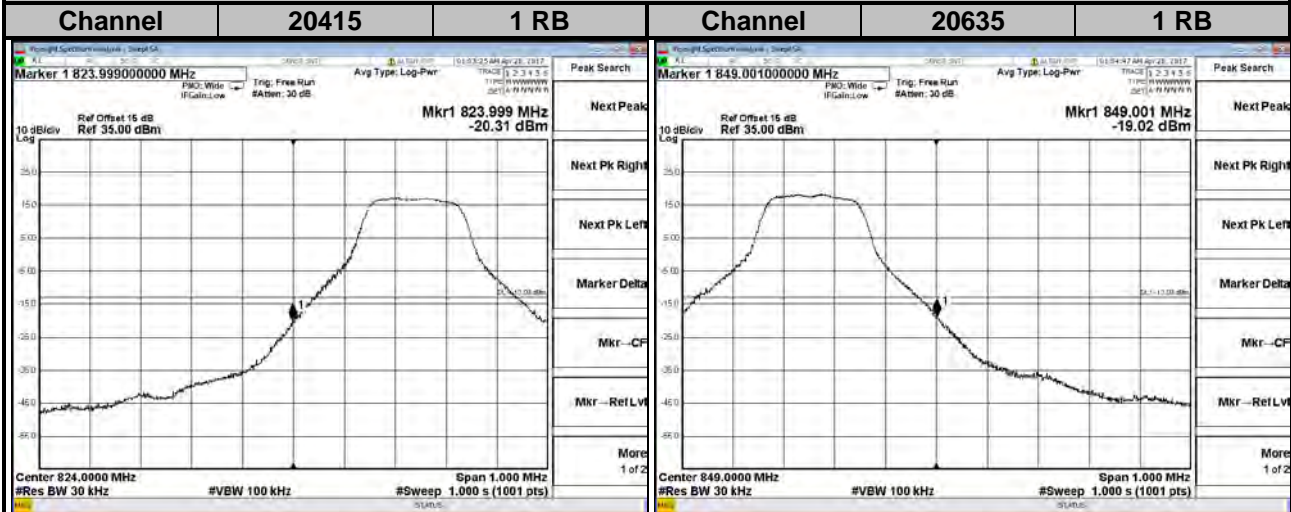

LTE Band 5

Channel Bandwidth: 5 MHz

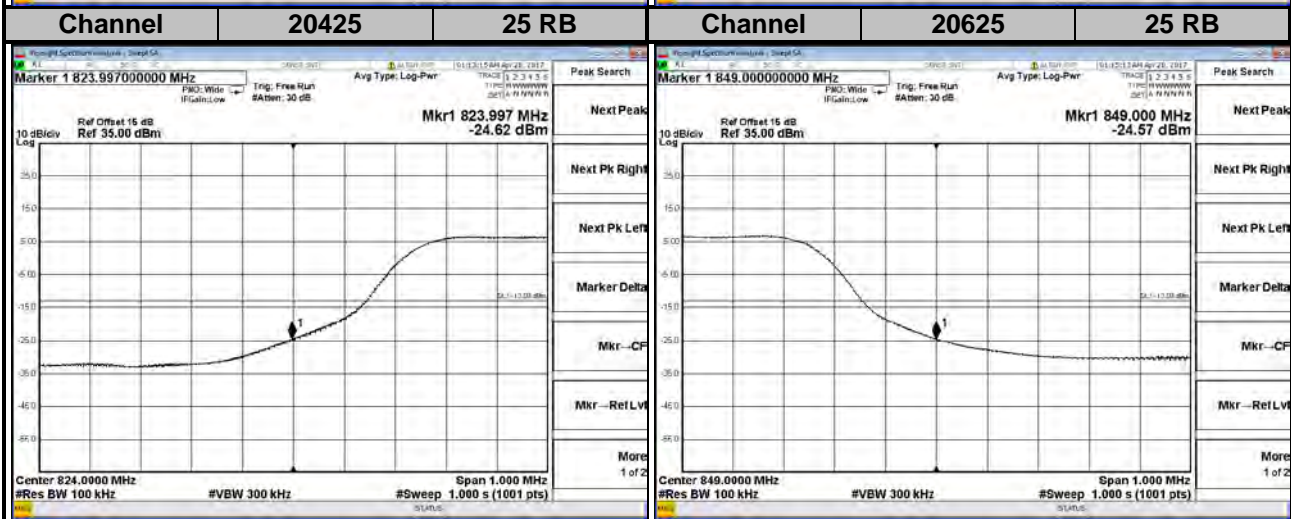
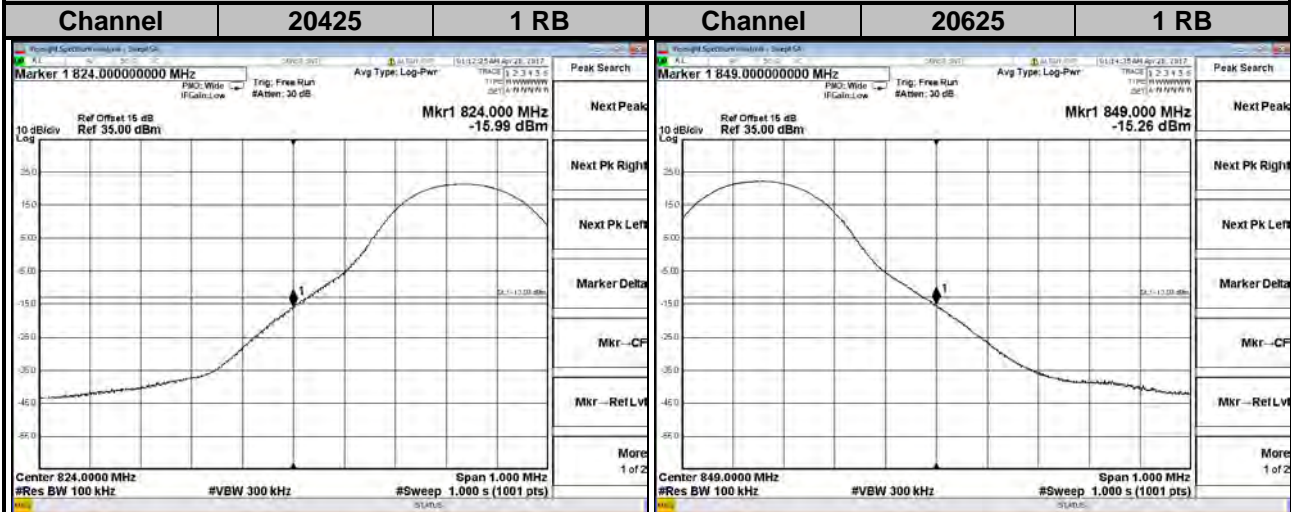

LTE Band 5

Channel Bandwidth: 10 MHz

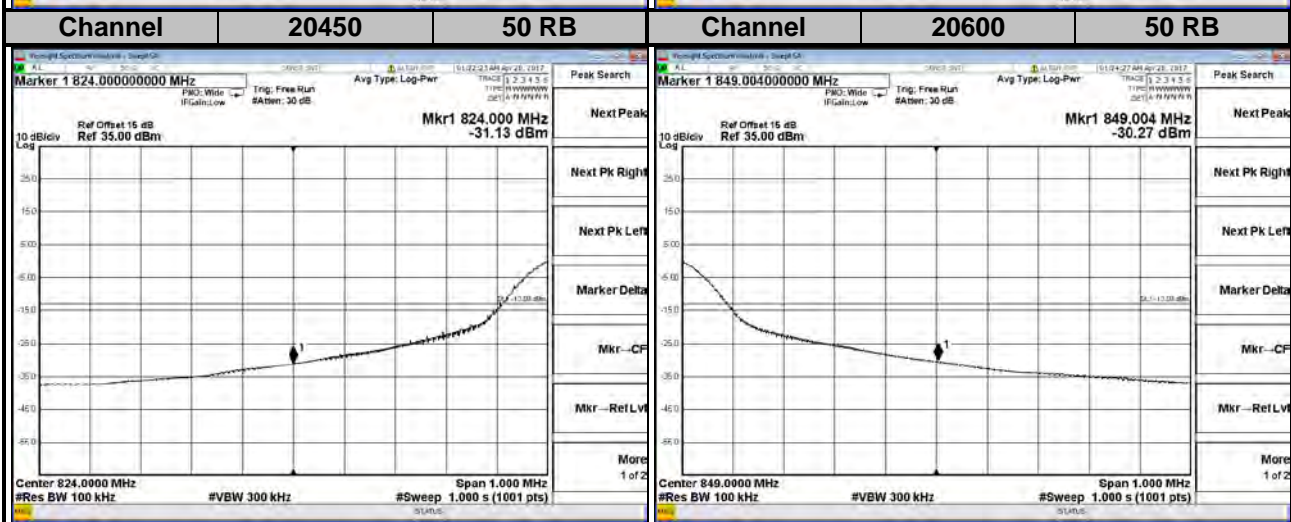
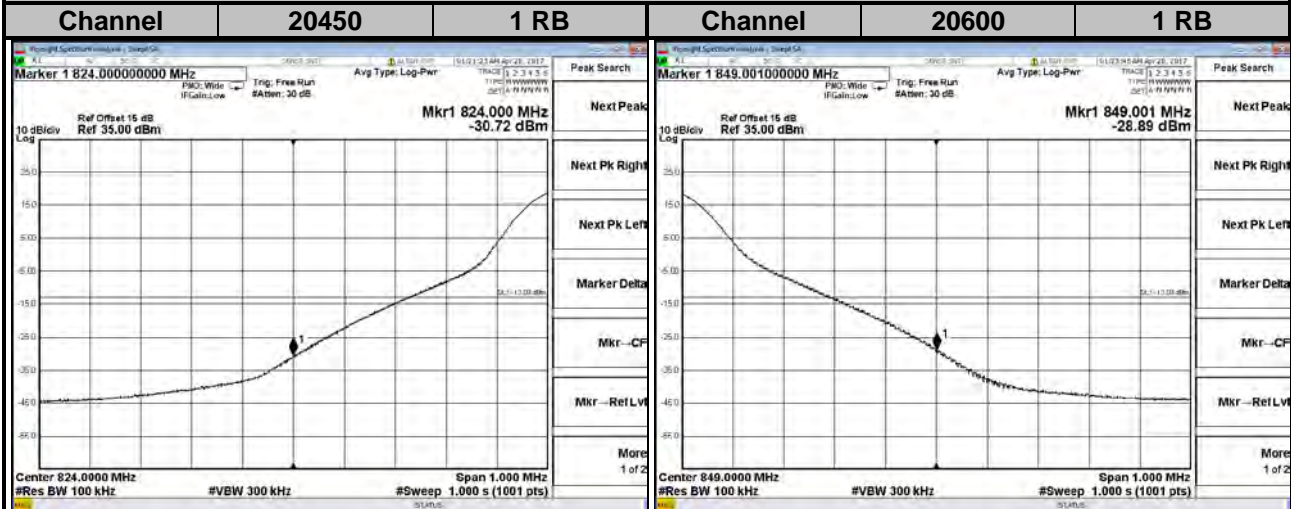

LTE Band 26

Channel Bandwidth: 1.4 MHz

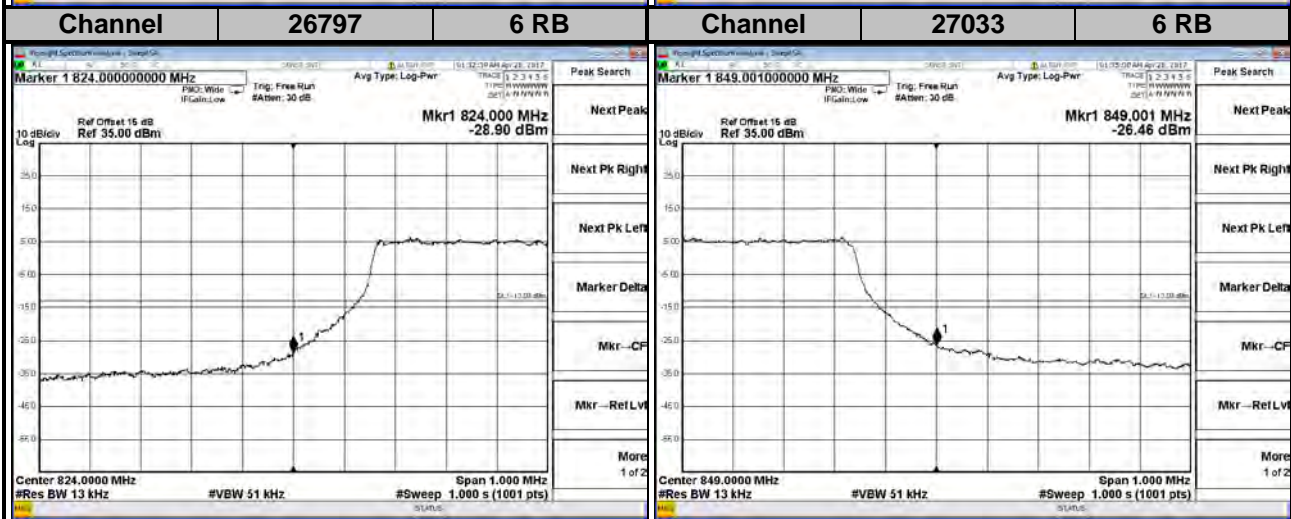
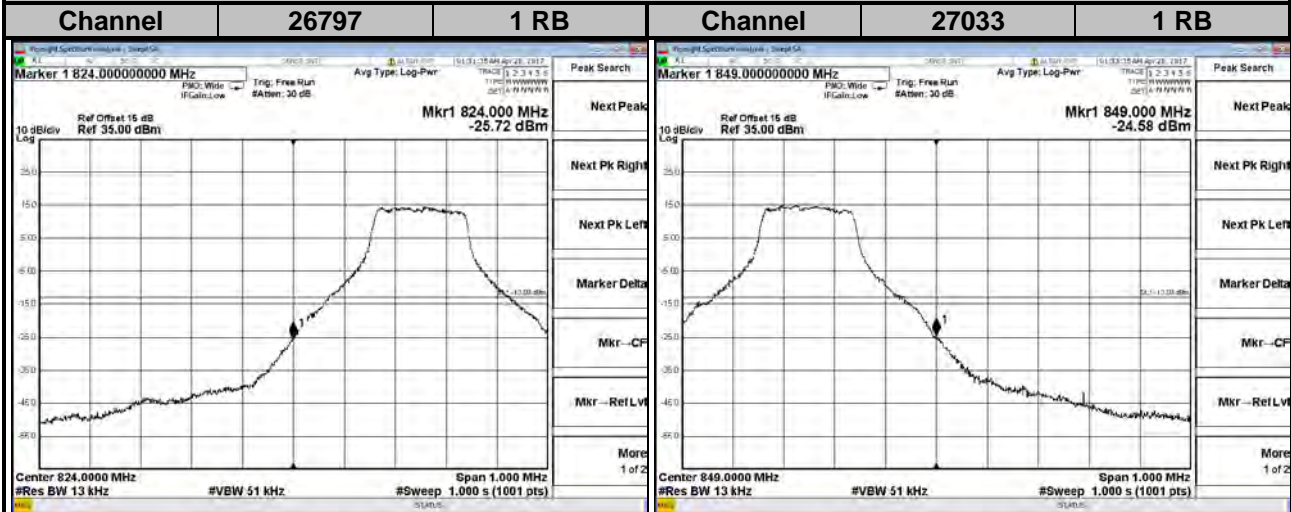

LTE Band 26

Channel Bandwidth: 3 MHz

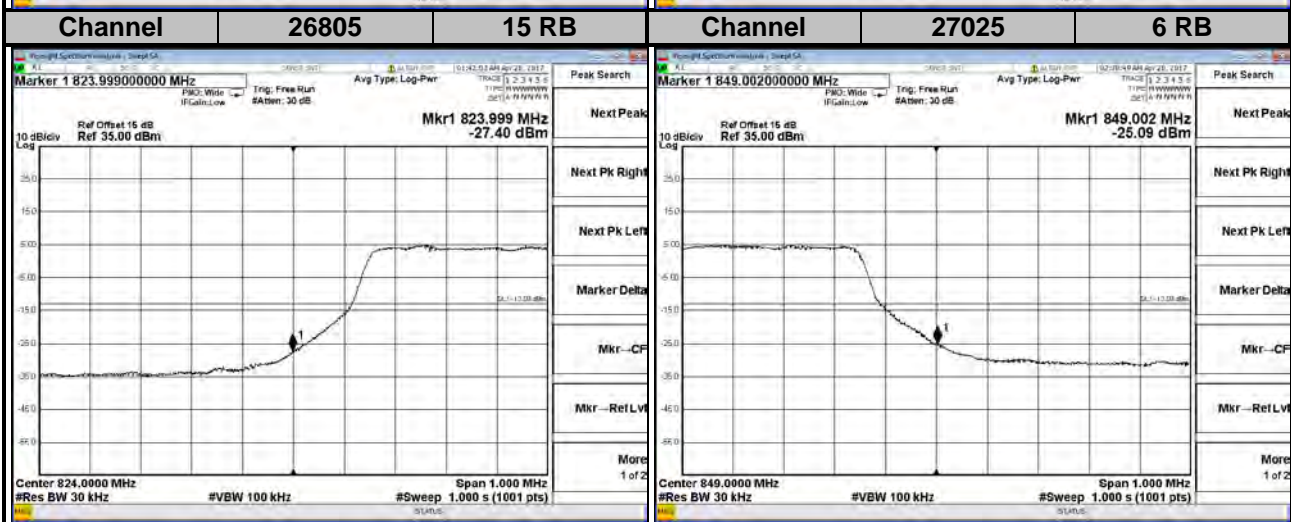
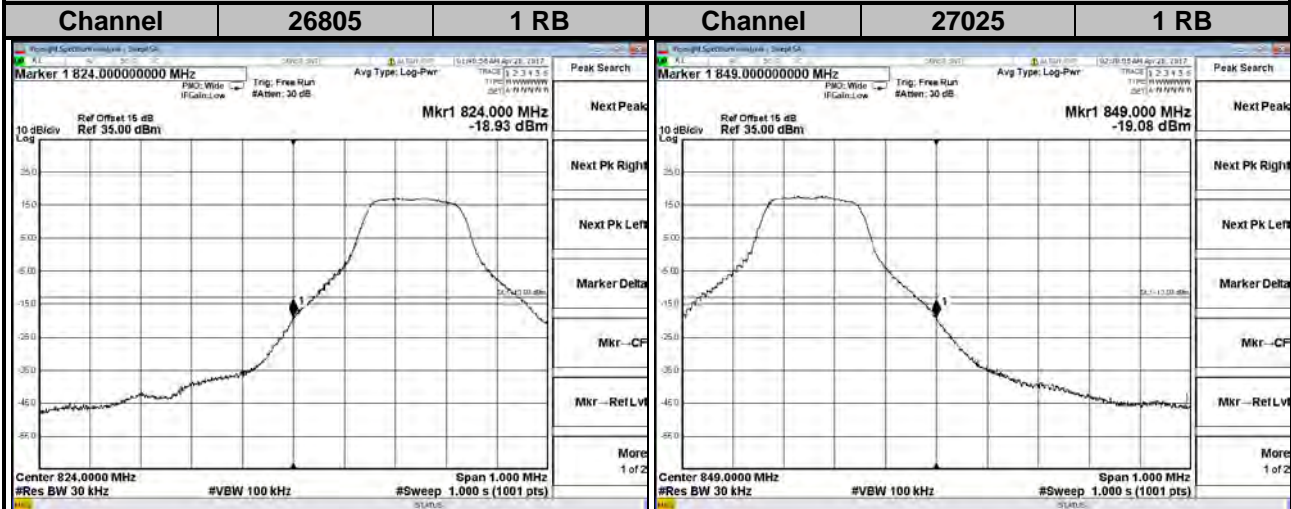

LTE Band 26

Channel Bandwidth: 5 MHz

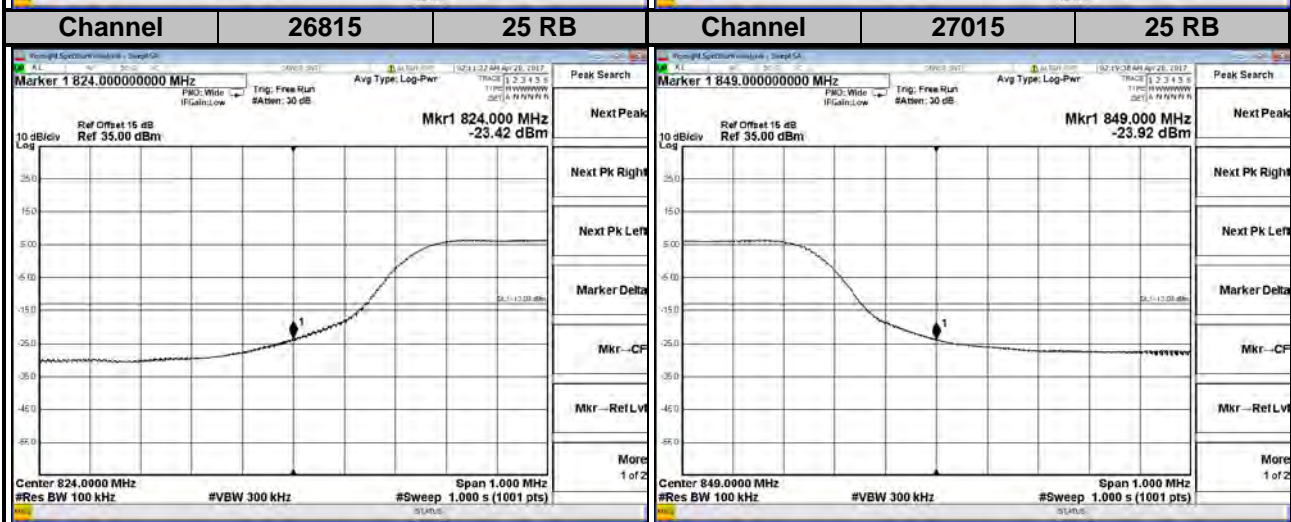
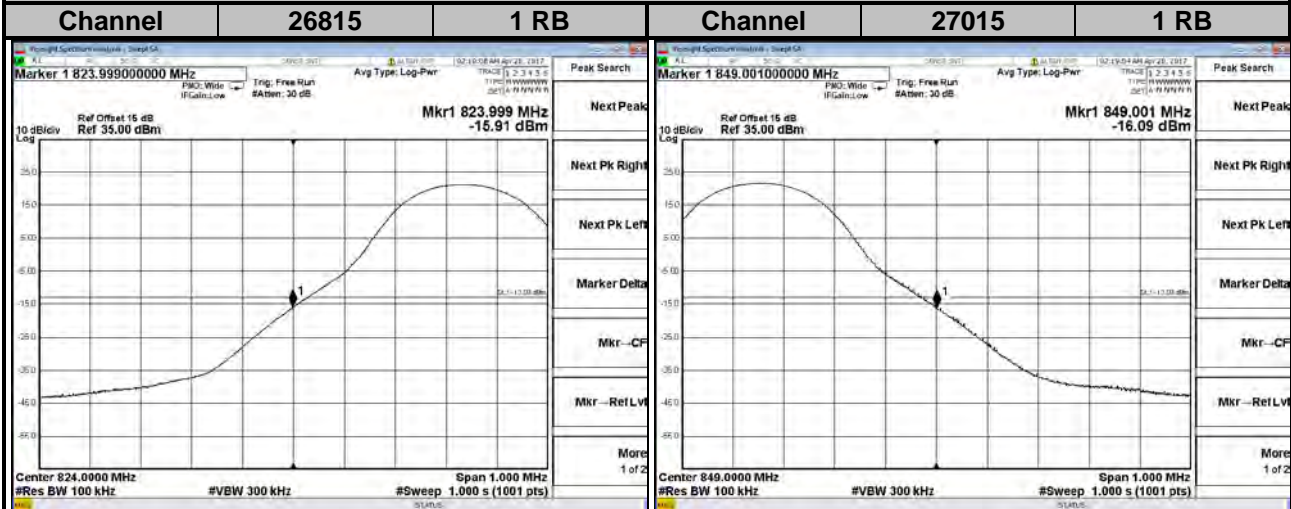

LTE Band 26

Channel Bandwidth: 10 MHz

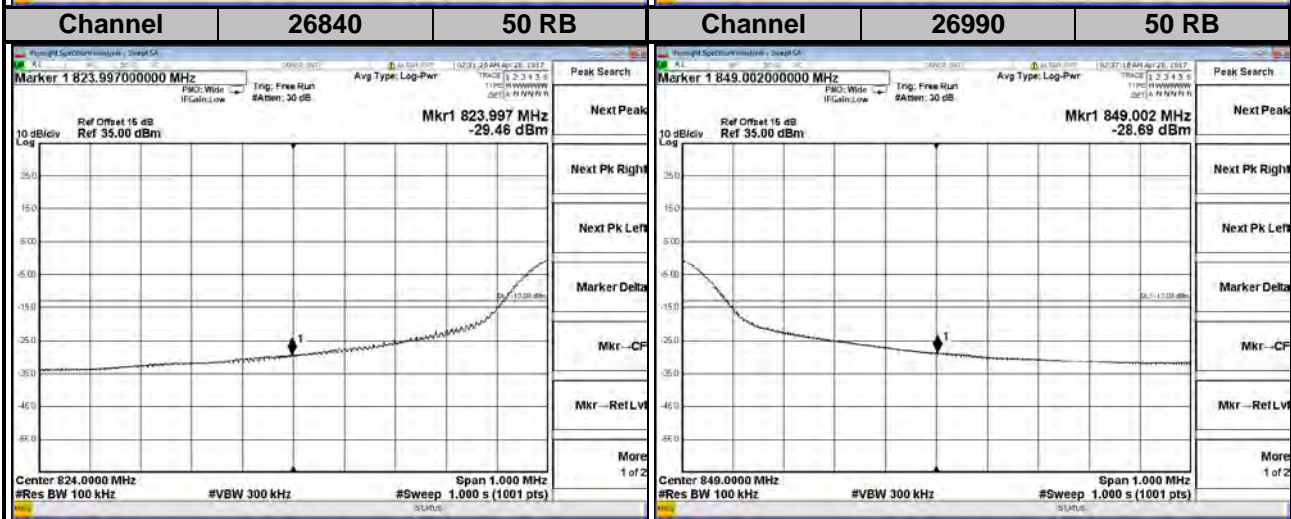
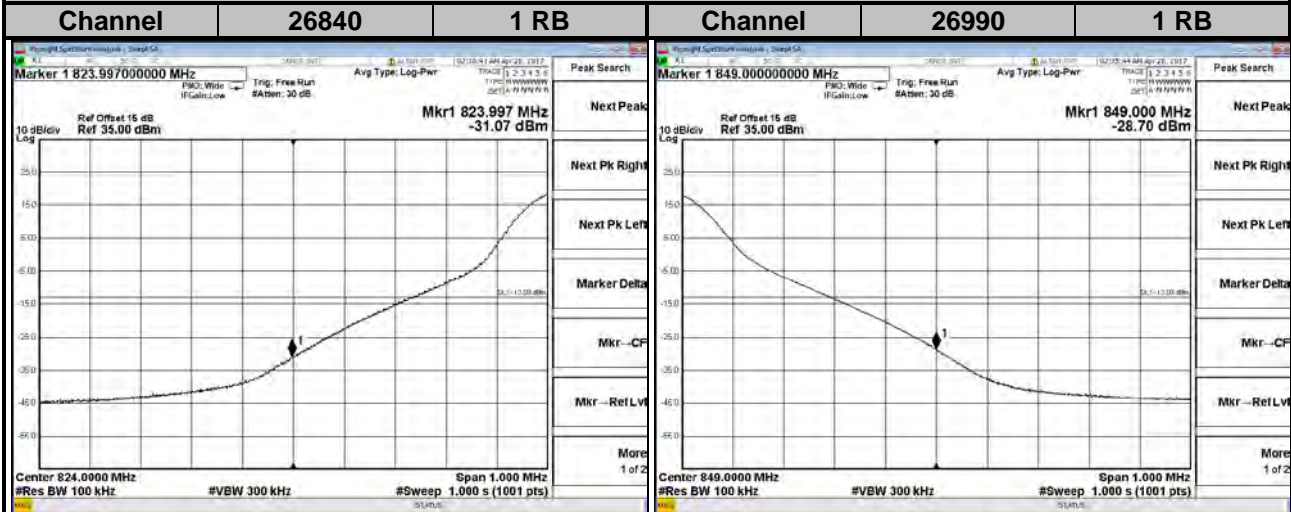

LTE Band 26

Channel Bandwidth: 15 MHz

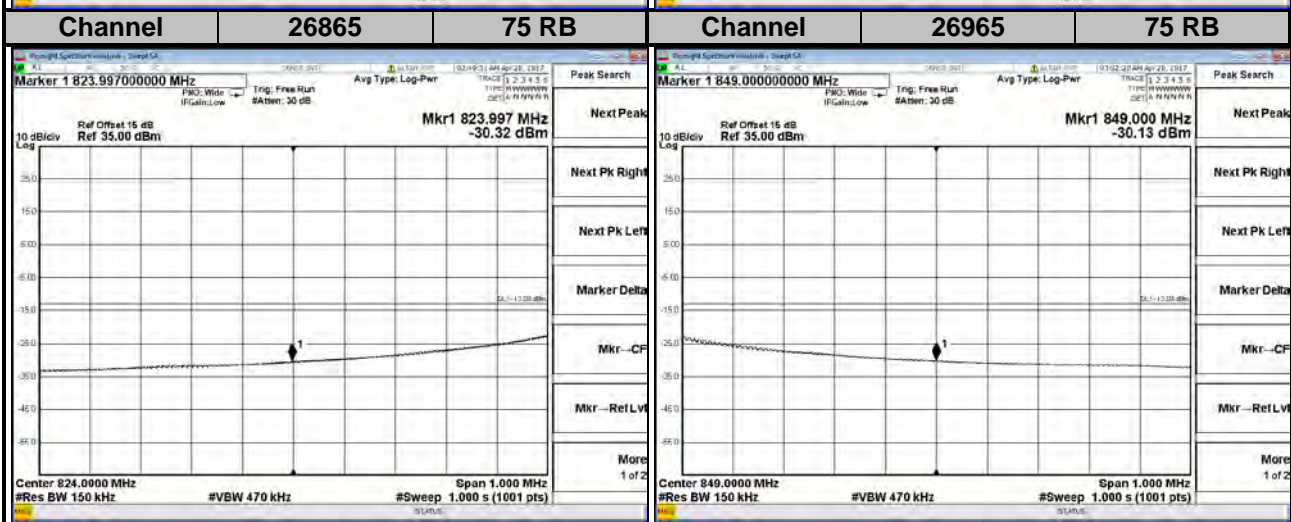
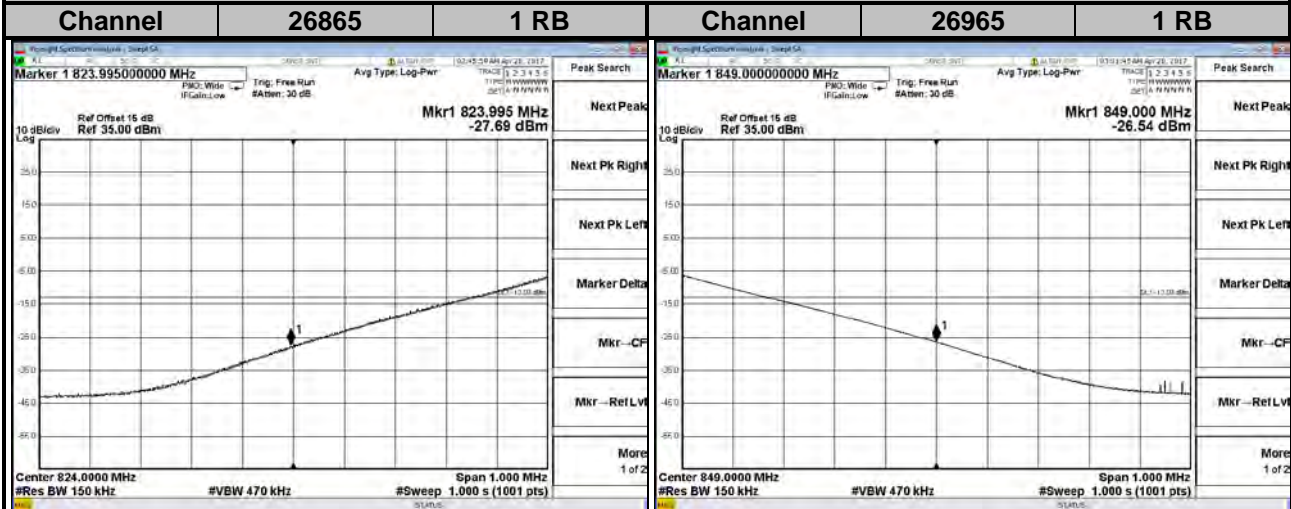

4.5 Peak to Average Ratio

4.5.1 Limits of Peak to Average Ratio Measurement

In measuring transmissions in this band using an average power technique, the peak to-average ratio (PAR) of the transmission may not exceed 13 dB.

4.5.2 Test Setup

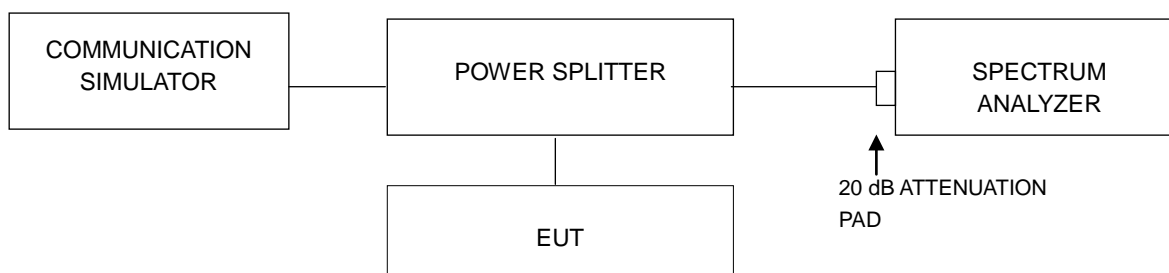

4.5.3 Test Procedures

1. Set resolution/measurement bandwidth \geq signal's occupied bandwidth;
2. Set the number of counts to a value that stabilizes the measured CCDF curve;
3. Record the maximum PAPR level associated with a probability of 0.1 %.

4.5.4 Test Results

Channel	Frequency (MHz)	Peak to Average Ratio (dB)	Channel	Frequency (MHz)	Peak to Average Ratio (dB)
		WCDMA			CDMA
4132	826.4	2.96	1013	824.70	4.01
4182	836.4	2.84	384	836.52	3.43
4233	846.6	2.71	777	848.31	3.08

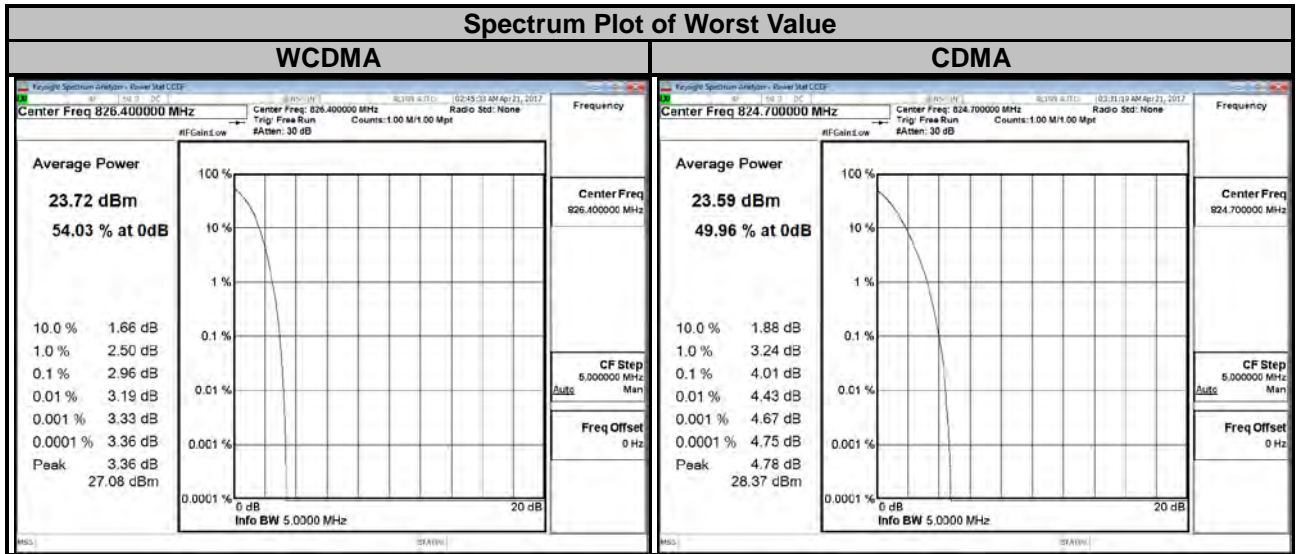

LTE Band 5

Channel Bandwidth: 1.4 MHz				Channel Bandwidth: 3 MHz			
Channel	Frequency (MHz)	Peak to Average Ratio (dB)		Channel	Frequency (MHz)	Peak to Average Ratio (dB)	
		QPSK	16QAM			QPSK	16QAM
20407	824.7	4.58	5.34	20415	825.5	4.67	5.40
20525	836.5	4.06	4.78	20525	836.5	3.92	4.61
20643	848.3	3.70	4.46	20635	847.5	3.73	4.49

Spectrum Plot of Worst Value

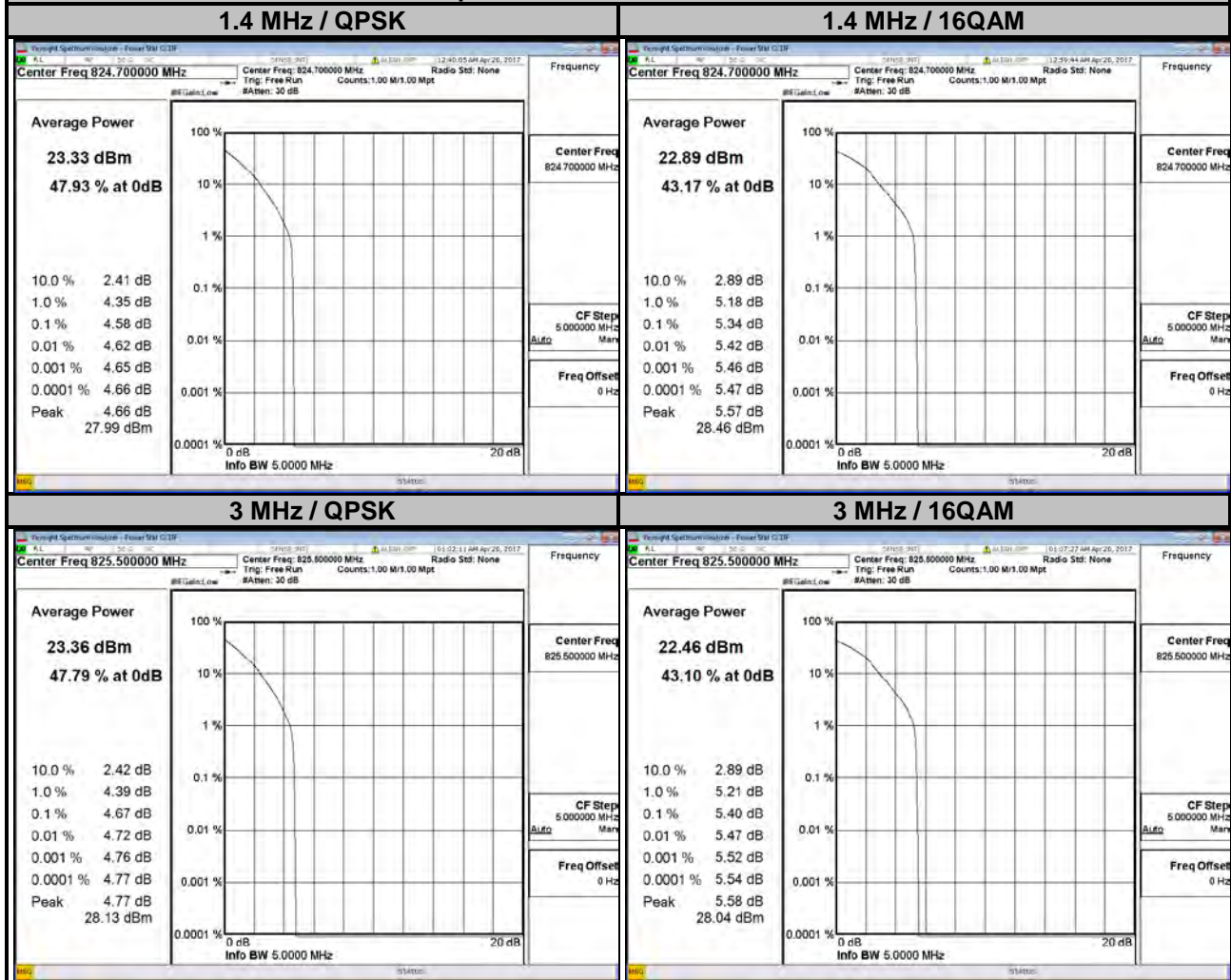

LTE Band 5

Channel Bandwidth: 5 MHz				Channel Bandwidth: 10 MHz			
Channel	Frequency (MHz)	Peak to Average Ratio (dB)		Channel	Frequency (MHz)	Peak to Average Ratio (dB)	
		QPSK	16QAM			QPSK	16QAM
20425	826.5	4.59	5.31	20450	829.0	4.57	5.24
20525	836.5	3.59	4.39	20525	836.5	3.66	4.46
20625	846.5	4.01	4.78	20600	844.0	4.35	5.11

Spectrum Plot of Worst Value

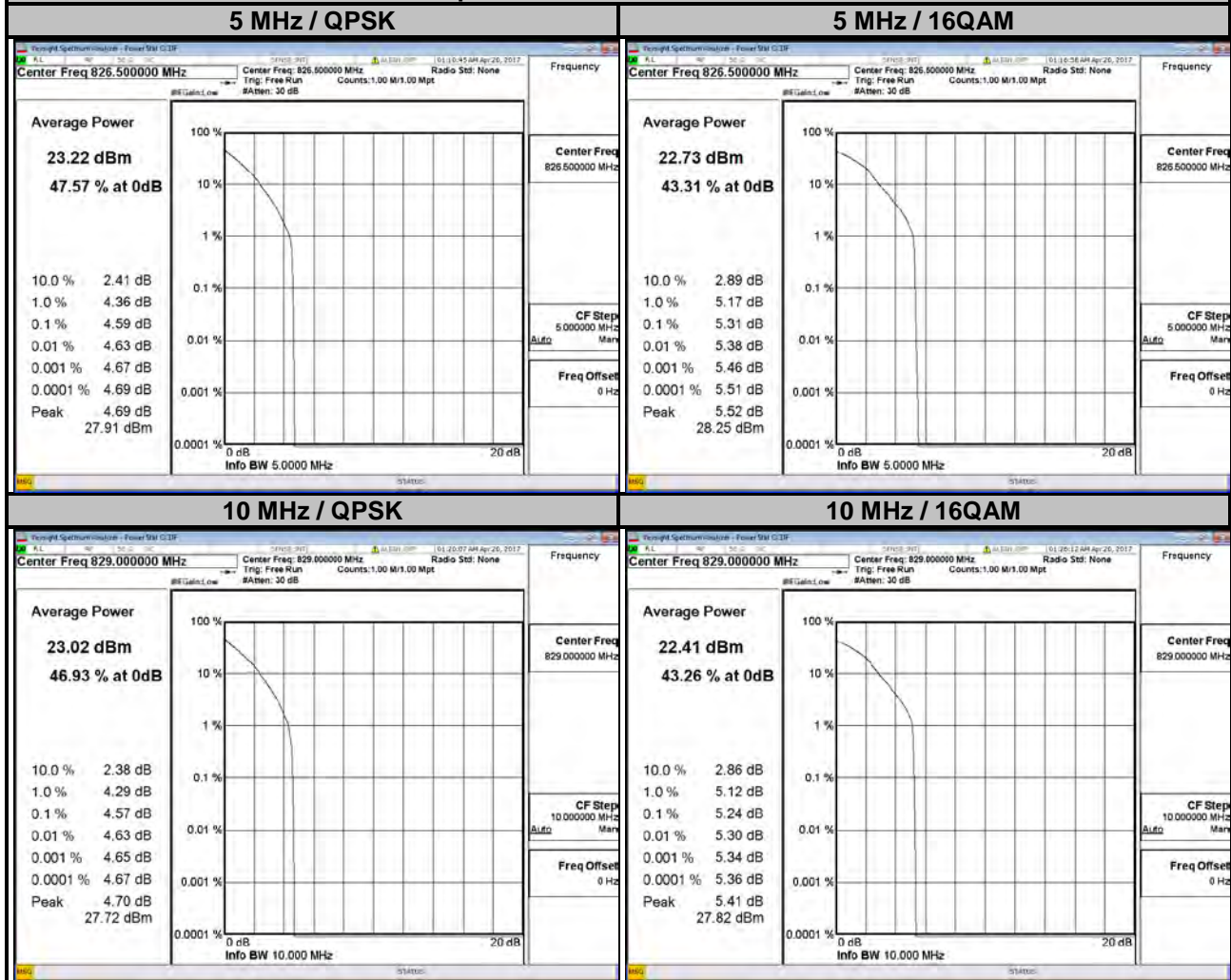

LTE Band 26

Channel Bandwidth: 1.4 MHz				Channel Bandwidth: 3 MHz			
Channel	Frequency (MHz)	Peak to Average Ratio (dB)		Channel	Frequency (MHz)	Peak to Average Ratio (dB)	
		QPSK	16QAM			QPSK	16QAM
26797	824.7	4.38	5.13	26805	825.5	4.41	5.21
26915	836.5	3.85	4.80	26915	836.5	3.82	4.71
27033	848.3	3.81	4.56	27025	847.5	3.45	4.57

Spectrum Plot of Worst Value

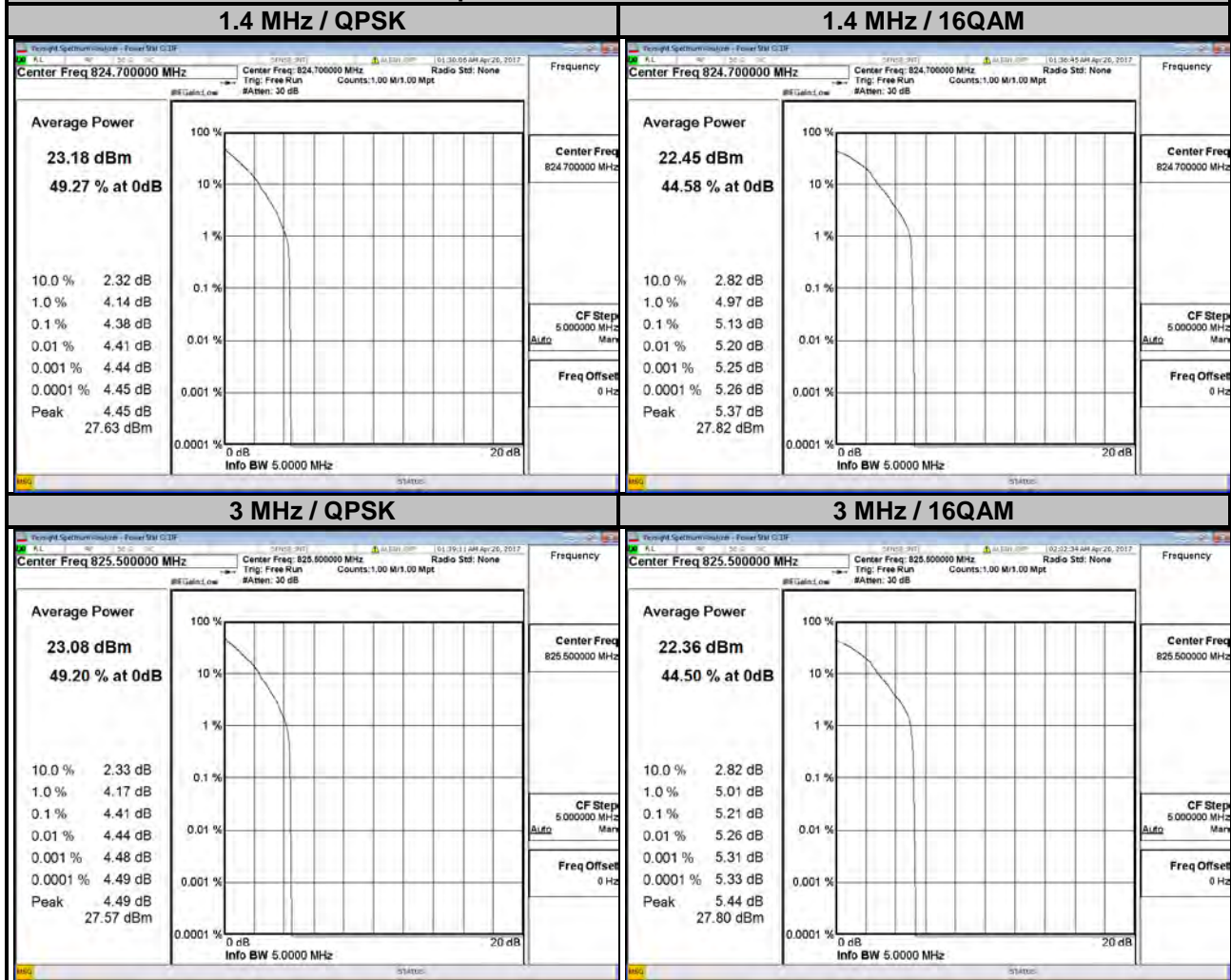

LTE Band 26

Channel Bandwidth: 5 MHz				Channel Bandwidth: 10 MHz			
Channel	Frequency (MHz)	Peak to Average Ratio (dB)		Channel	Frequency (MHz)	Peak to Average Ratio (dB)	
		QPSK	16QAM			QPSK	16QAM
26815	826.5	4.34	5.07	26840	829.0	4.30	5.09
26915	836.5	3.77	4.52	26915	836.5	3.71	4.33
27015	846.5	3.93	4.67	26990	844.0	4.27	5.04

Spectrum Plot of Worst Value

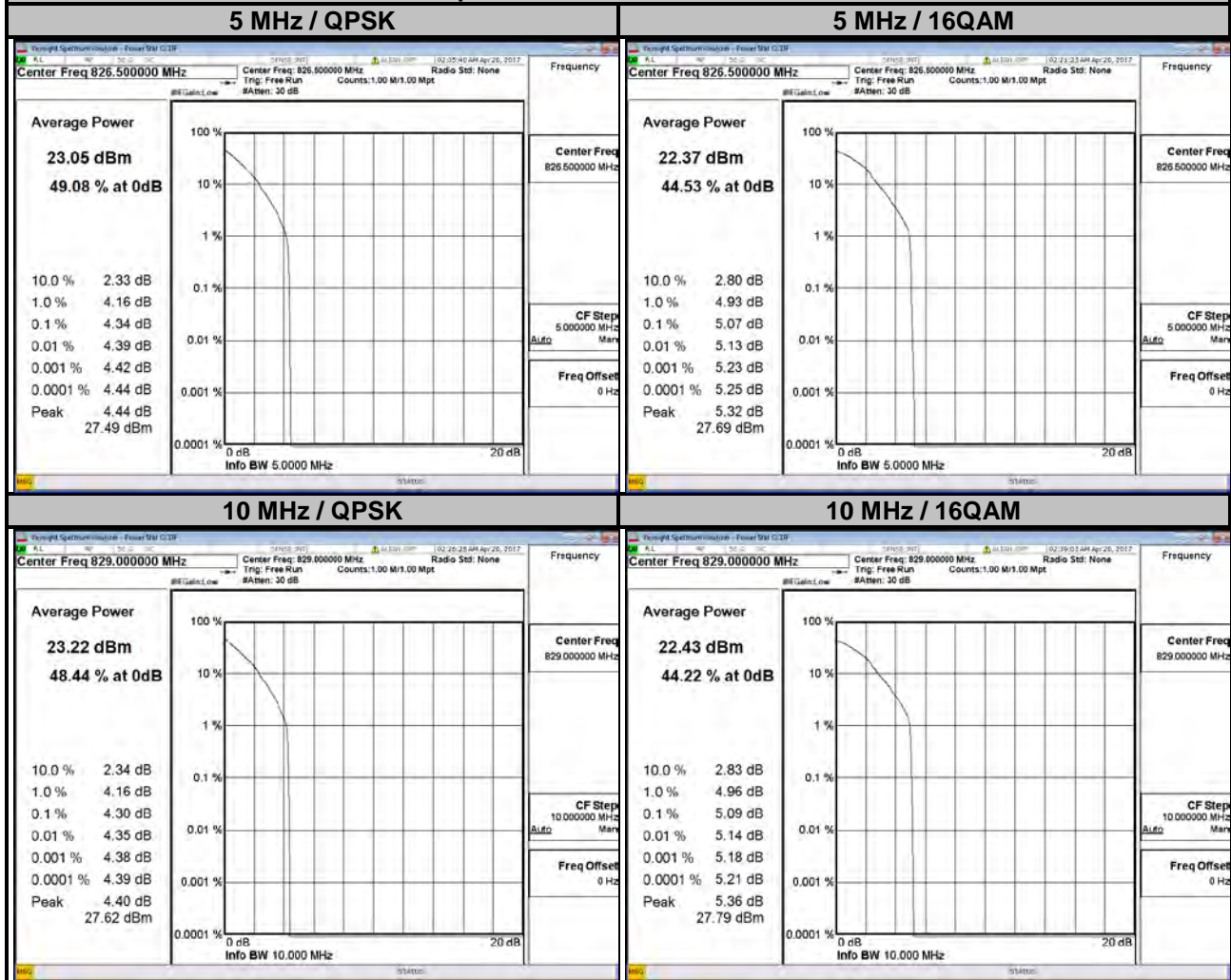

LTE Band 26			
Channel Bandwidth: 15 MHz			
Channel	Frequency (MHz)	Peak to Average Ratio (dB)	
		QPSK	16QAM
26865	831.5	4.23	4.96
26915	836.5	3.74	4.69
26965	841.5	3.62	4.42

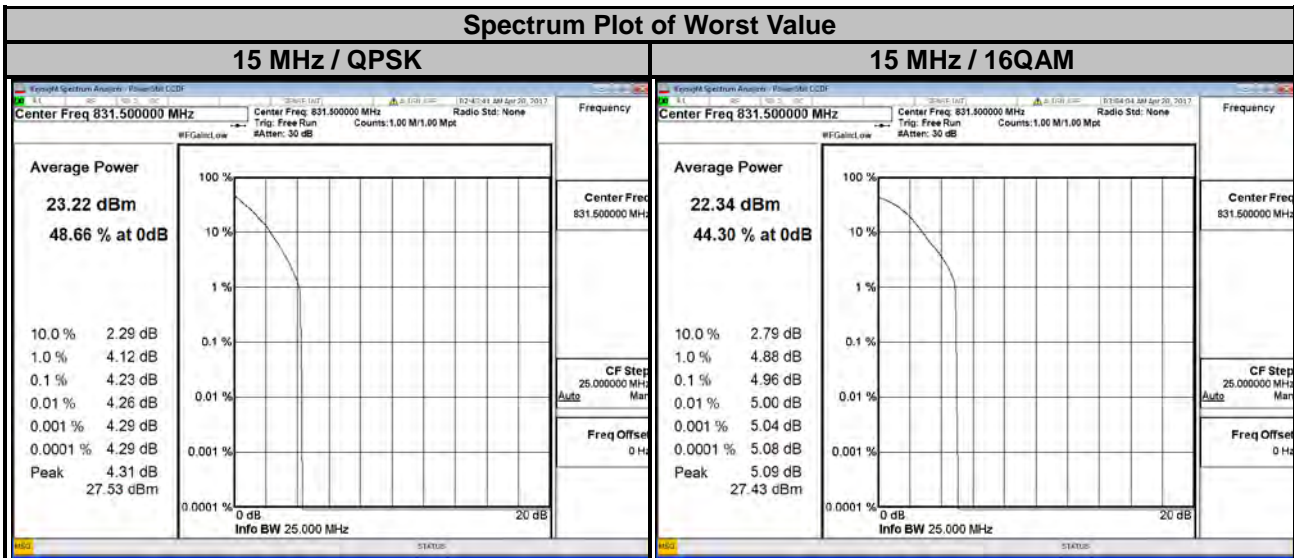

4.6 Conducted Spurious Emissions

4.6.1 Limits of Conducted Spurious Emissions Measurement

The power of any emission outside of the authorized operating frequency ranges must be attenuated below the transmitting power (P) by a factor of at least $43 + 10 \log(P)$ dB. The emission limit equal to -13 dBm.

4.6.2 Test Setup

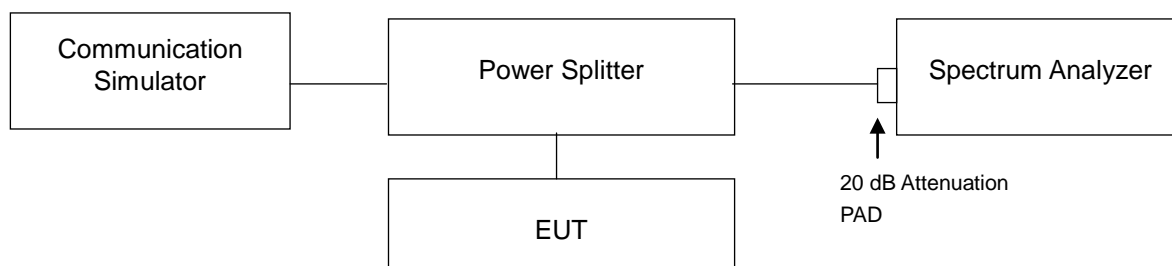

4.6.3 Test Procedure

- The EUT makes a phone call to the communication simulator. All measurements were done at low, middle and high operational frequency range.
- Measuring frequency range is from 9 kHz to 9 GHz. 20 dB attenuation pad is connected with spectrum. RBW=1 MHz and VBW=3 MHz is used for conducted emission measurement.

4.6.4 Test Results

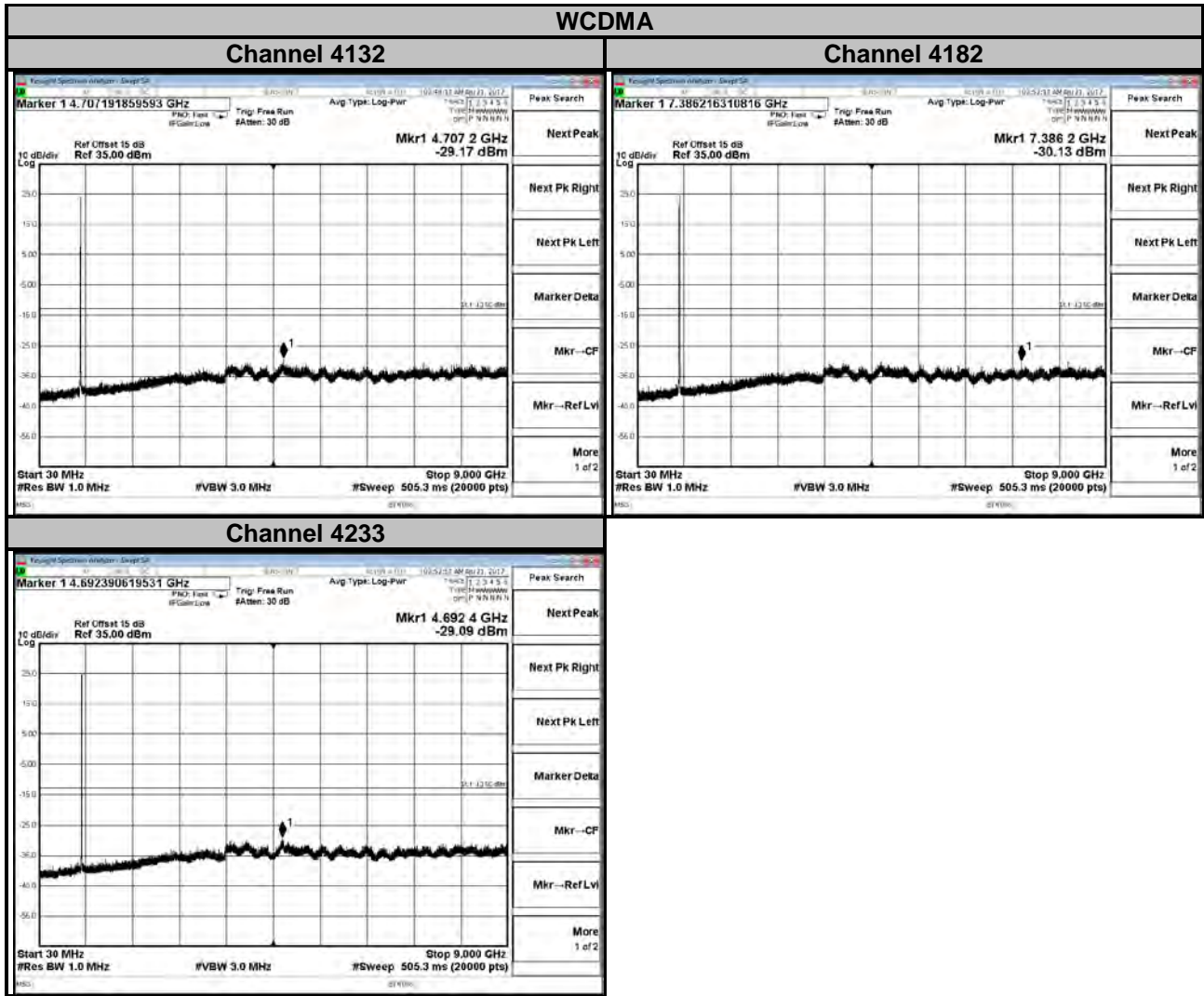

CDMA

Channel 1013

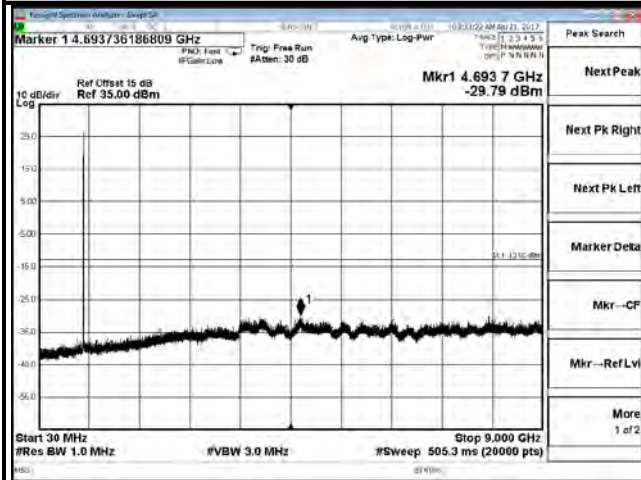

Channel 384

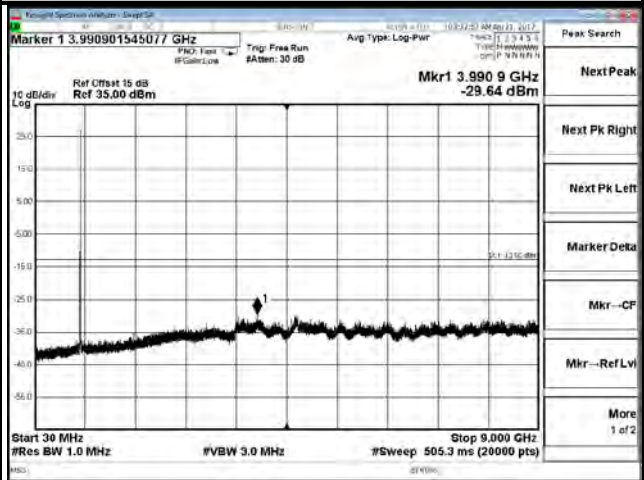

Channel 777

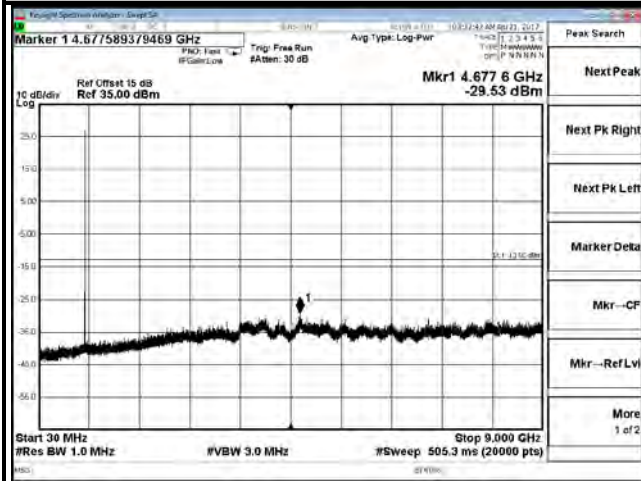

LTE Band 5

Channel Bandwidth: 1.4 MHz

Channel 20407

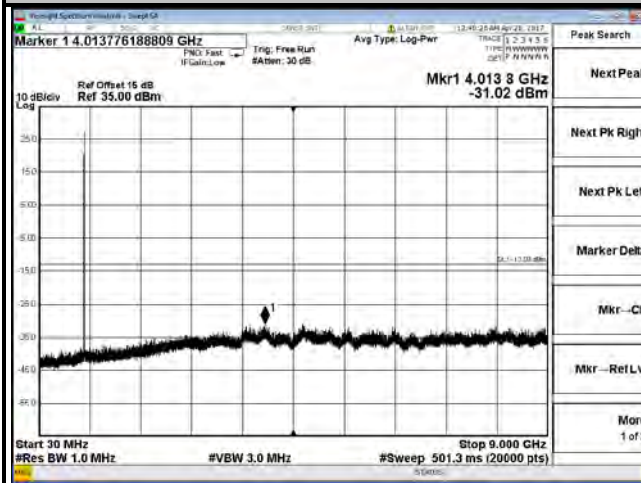

Channel 20525

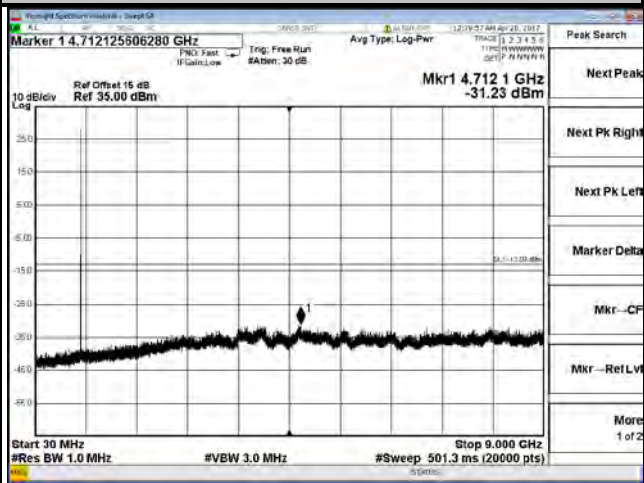

Channel 20643

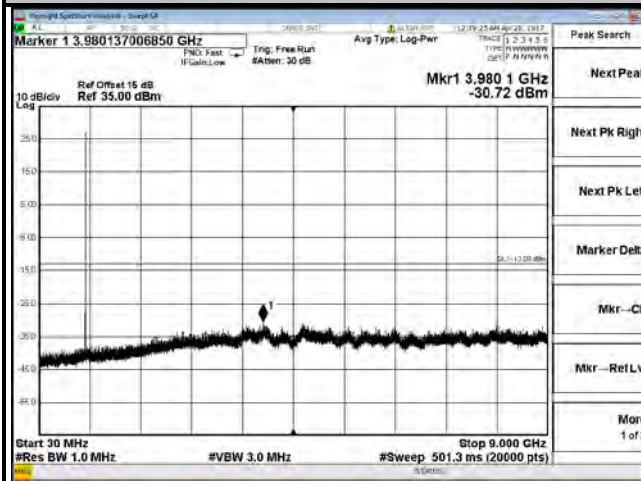

LTE Band 5
Channel Bandwidth: 3 MHz

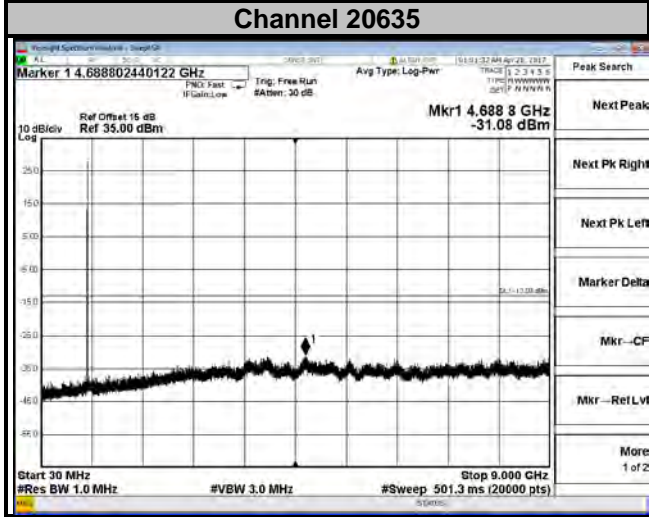
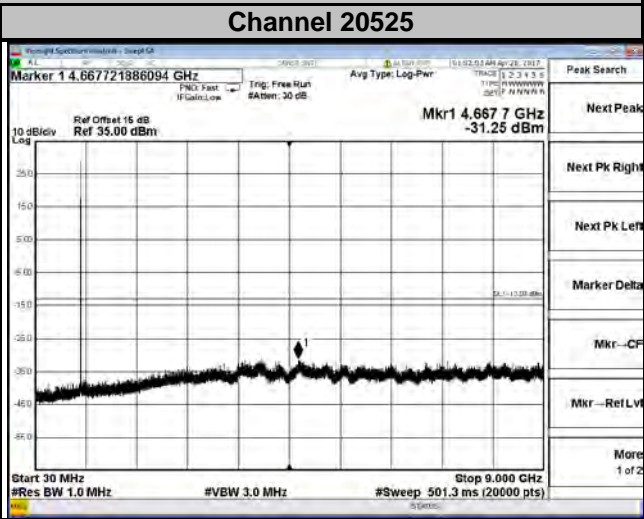
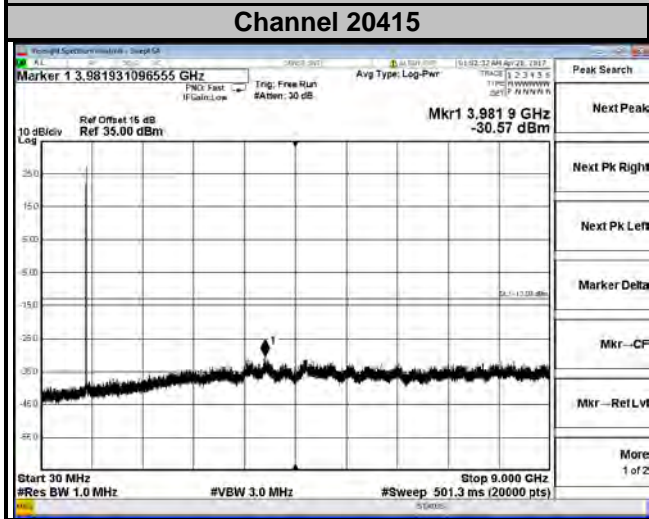

LTE Band 5

Channel Bandwidth: 5 MHz

Channel 20425

Channel 20525

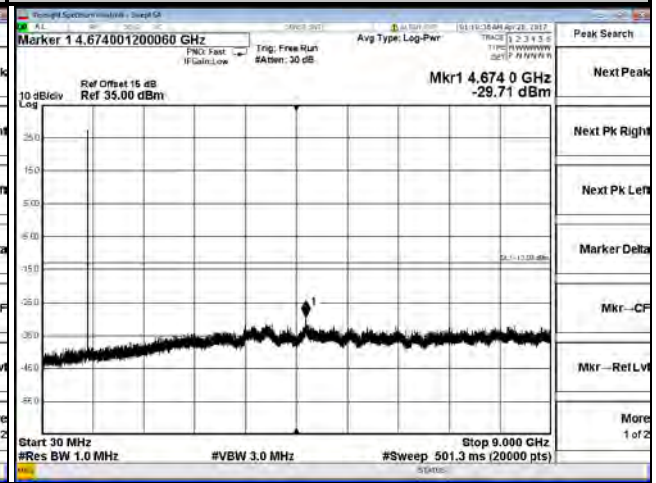
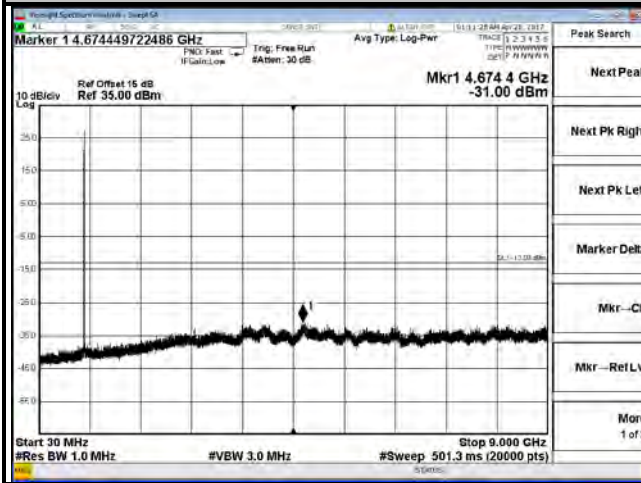

Channel 20625

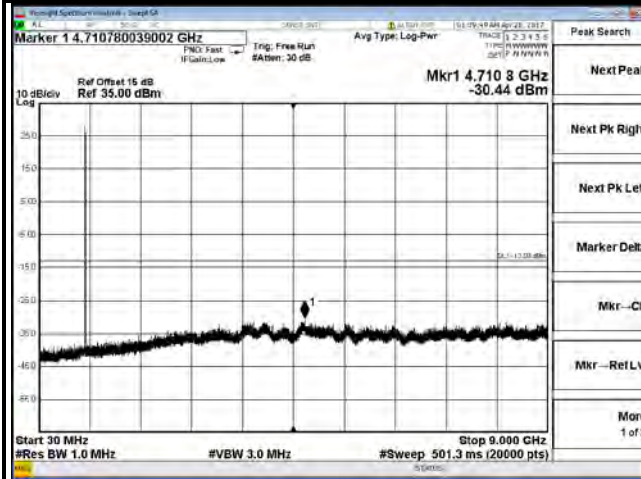

LTE Band 5

Channel Bandwidth: 10 MHz

Channel 20450

Channel 20525

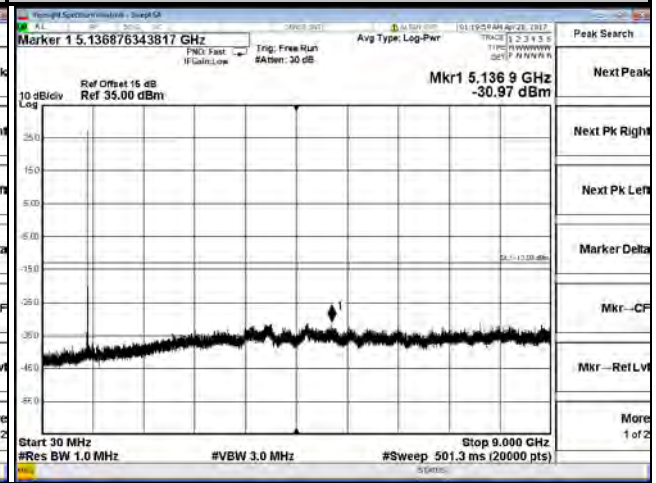
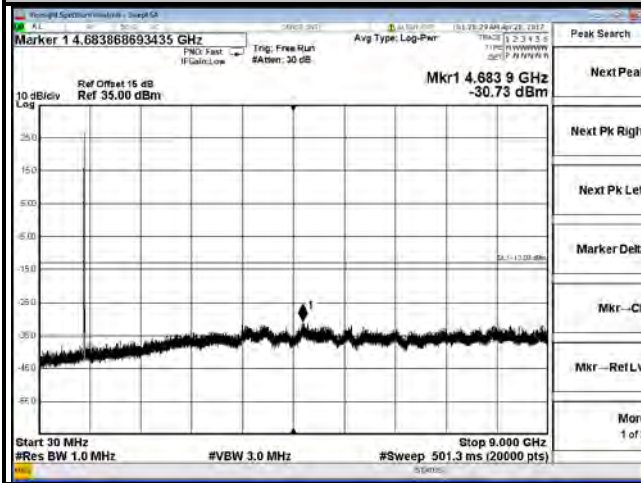

Channel 20600

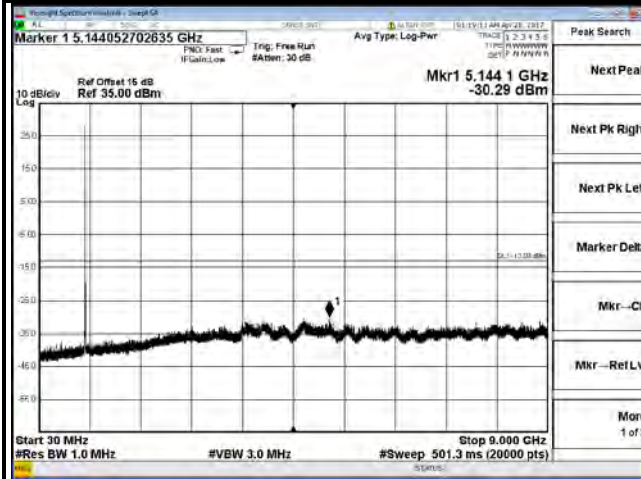

LTE Band 26

Channel Bandwidth: 1.4 MHz

Channel 26797

Channel 26915

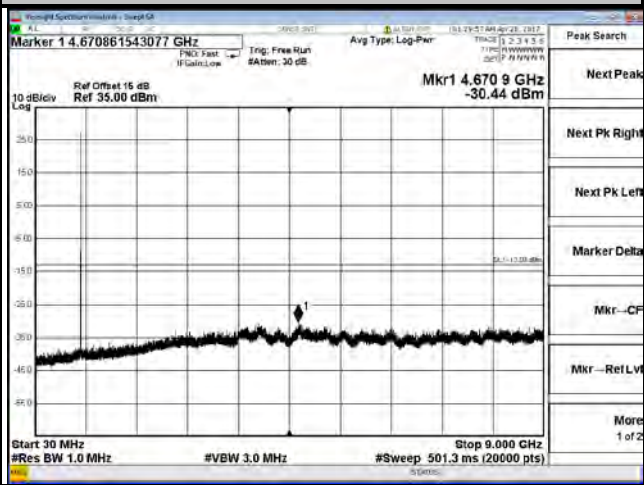
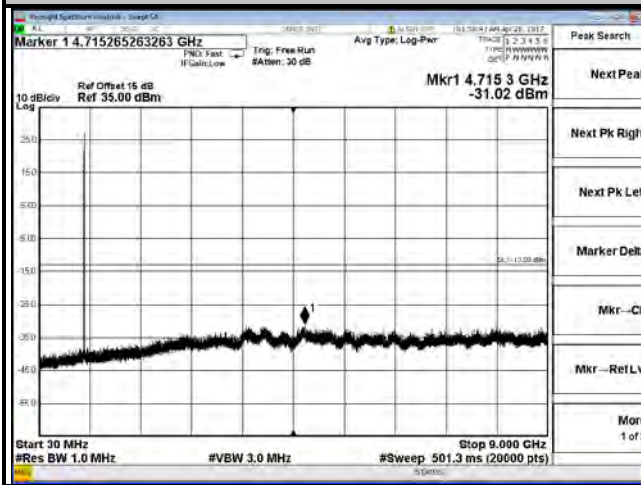

Channel 27033

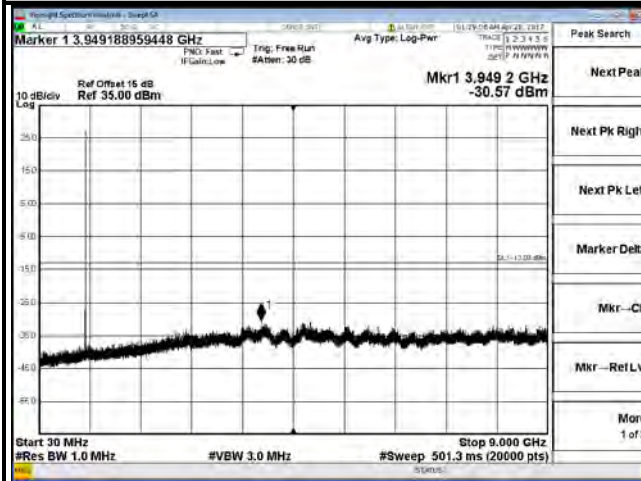

LTE Band 26

Channel Bandwidth: 3 MHz

Channel 26805

Channel 26915

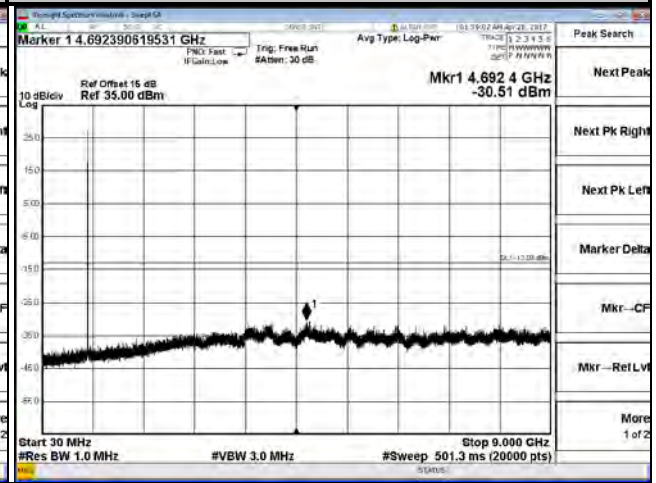
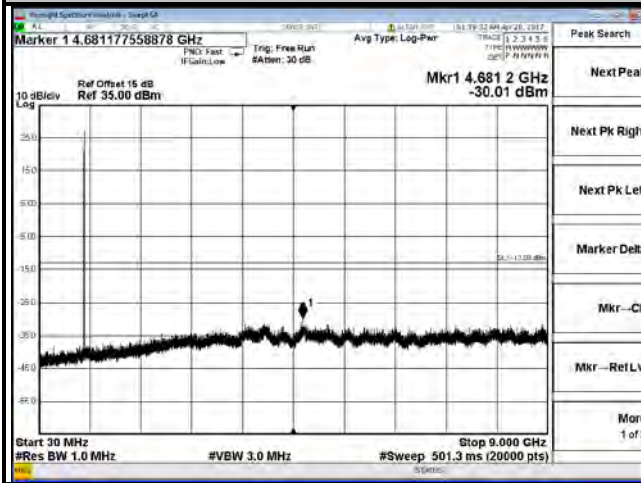

Channel 27025

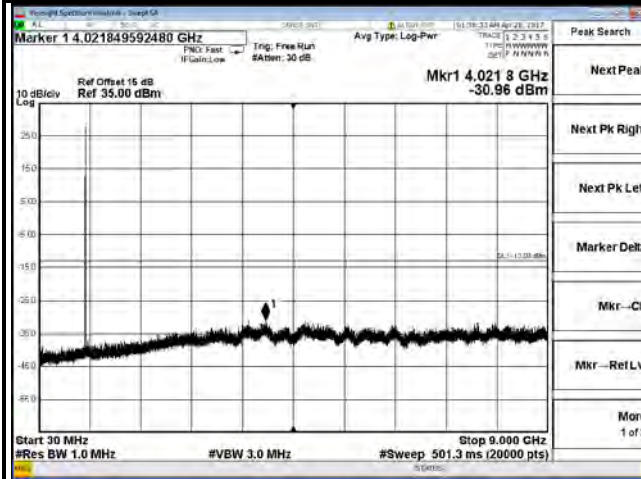

LTE Band 26

Channel Bandwidth: 5 MHz

Channel 26815

Channel 26915

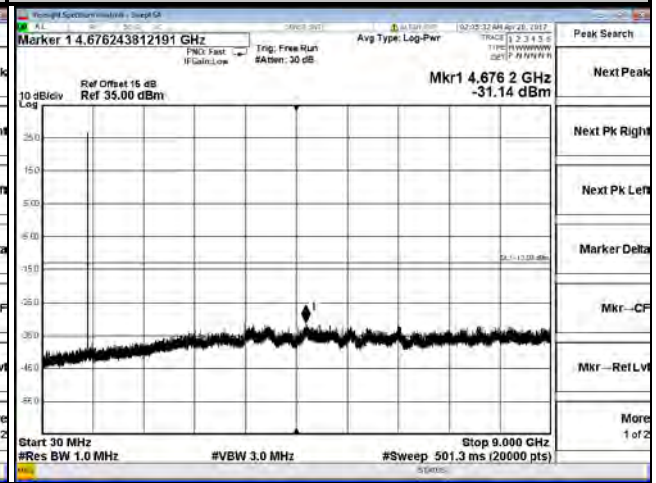
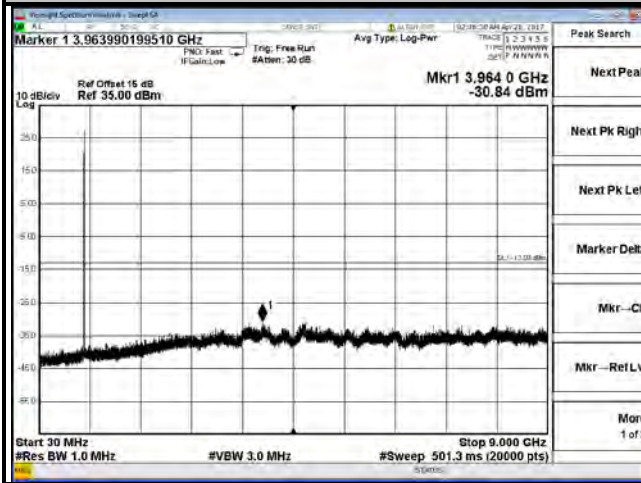

Channel 27015

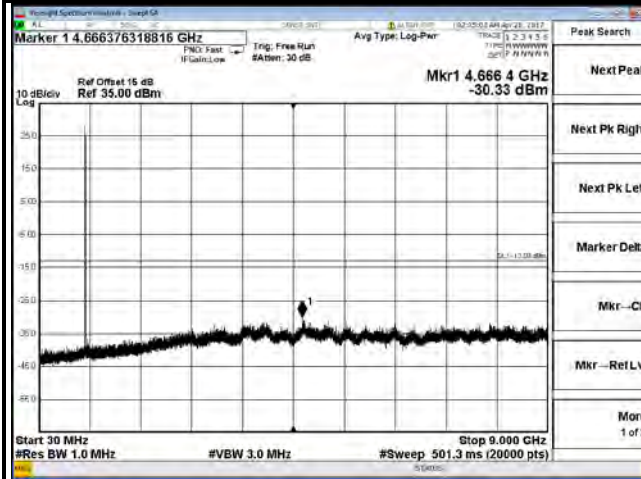

LTE Band 26

Channel Bandwidth: 10 MHz

Channel 26840

Channel 26915

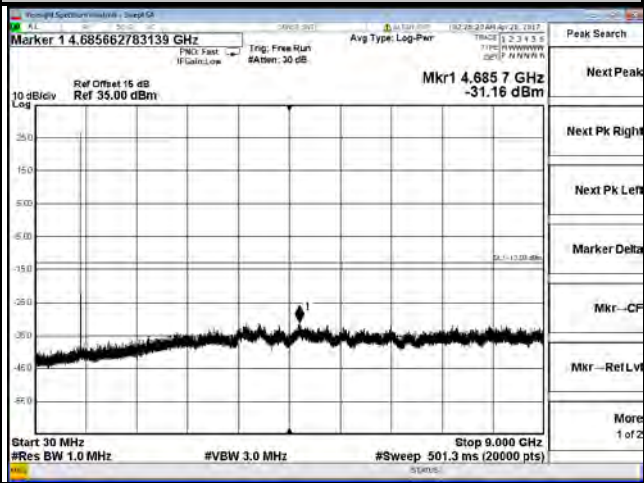
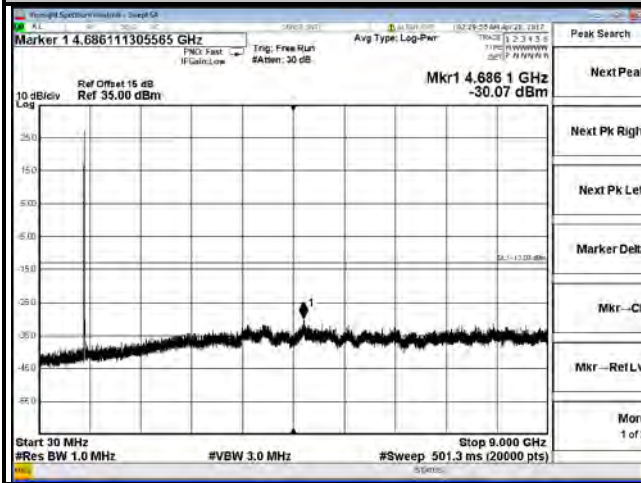

Channel 26990

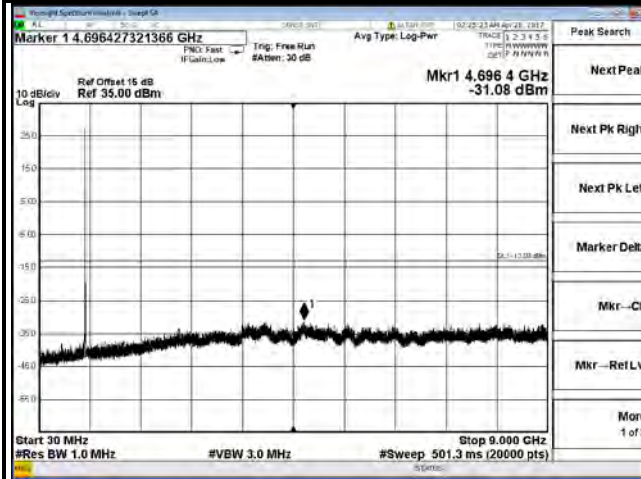

LTE Band 26

Channel Bandwidth: 15 MHz

Channel 26865

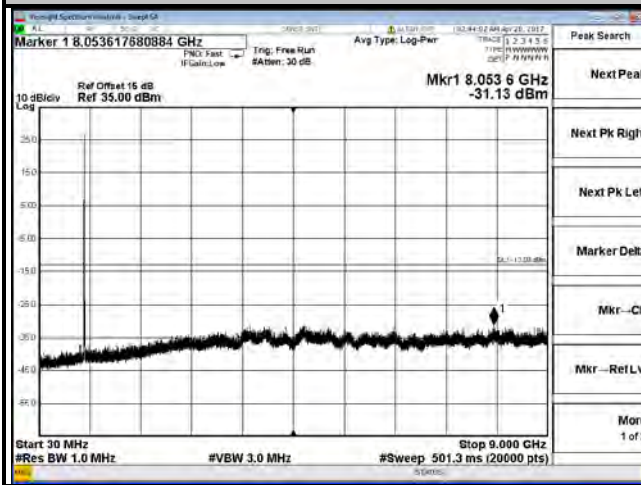

Channel 26915

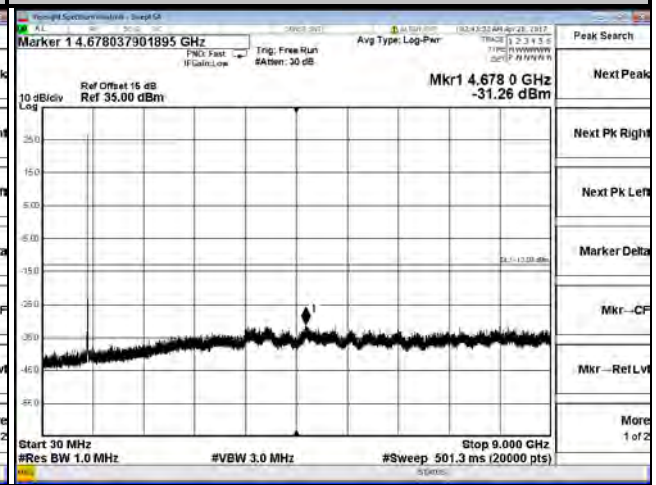

Channel 26965

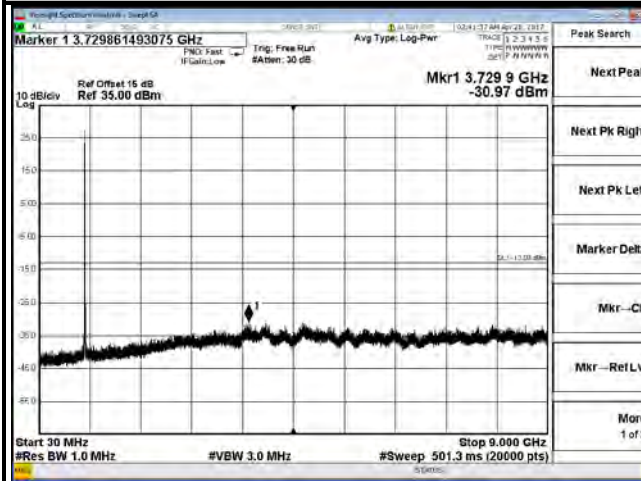

4.7 Radiated Emission Measurement

4.7.1 Limits of Radiated Emission Measurement

The power of any emission outside of the authorized operating frequency ranges must be attenuated below the transmitting power (P) by a factor of at least $43 + 10 \log(P)$ dB. The emission limit is equal to -13 dBm.

4.7.2 Test Procedure

- Substitution method is used for E.I.R.P measurement. In the semi-anechoic chamber, EUT placed on the 0.8 m height of Turn Table, rotated the table around 360 degrees to search the maximum radiation power and receiver antenna shall be rotated vertical and horizontal polarization and moved height from 1 m to 4 m to find the maximum polar radiated power. The "Read Value" is the spectrum reading the maximum power value.
- The substitution horn antenna is substituted for EUT at the same position and signals generator export the CW signal to the substitution antenna via a TX cable. Rotated the Turn Table and moved receiving antenna to find the maximum radiation power. Adjust output power level of S.G to get a Value of spectrum reading equal to "Read Value" of step a. Record the power level of S.G
- $EIRP = \text{Output power level of S.G} - \text{TX cable loss} + \text{Antenna gain of substitution horn.}$
- E.R.P power can be calculated form E.I.R.P power by subtracting the gain of dipole, $E.R.P \text{ power} = E.I.P.R \text{ power} - 2.15 \text{ dBi.}$

NOTE: The resolution bandwidth and video bandwidth of test receiver/spectrum analyzer is 1 MHz/3 MHz.

4.7.3 Deviation from Test Standard

No deviation.

4.7.4 Test Setup

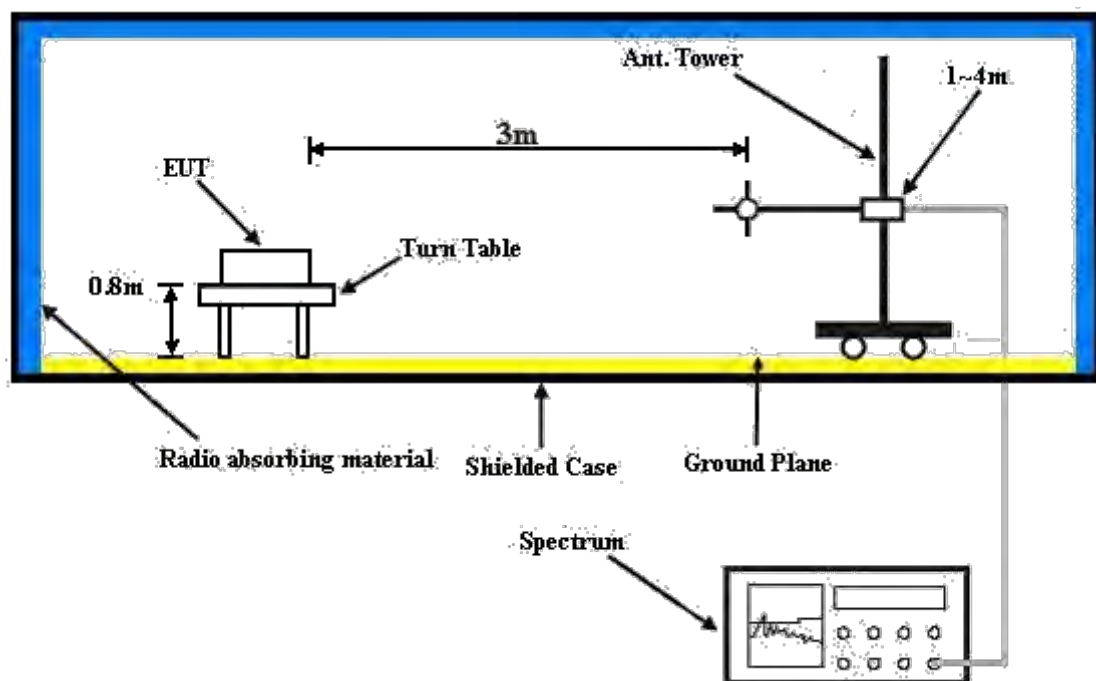

For the actual test configuration, please refer to the attached file (Test Setup Photo).

4.7.5 Test Results

WCDMA:
Low Channel



Bureau Veritas Consumer Products Services Ltd., Taoyuan Branch

A D T

Data: 5

Date: 2017-04-12

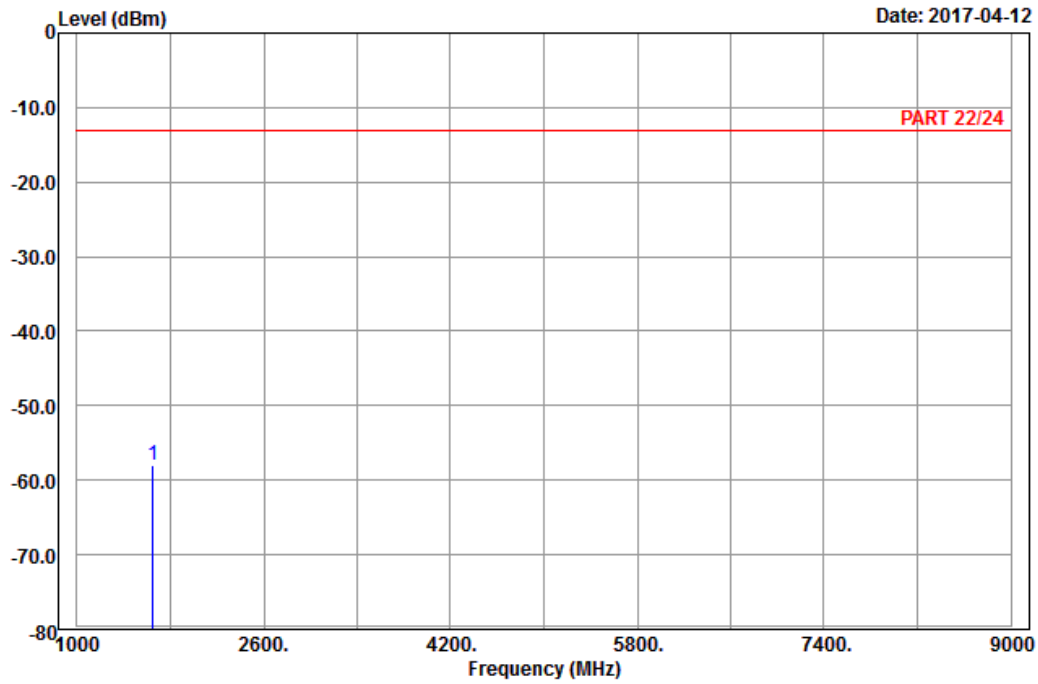

Site : 966 chamber 1
Condition: PART 22/24 Horizontal
Remark : Band V_Link_CH4132
Tested by: Charles Hsiao

	Freq	Level	Read Level	Limit Line	Over Limit	Factor	Remark
	MHz	dBm	dBm	dBm	dB	dB	
1	pp 1652.80	-58.04	-65.77	-13.00	-45.04	7.73	Peak



A D T

Data: 6

Date: 2017-04-12

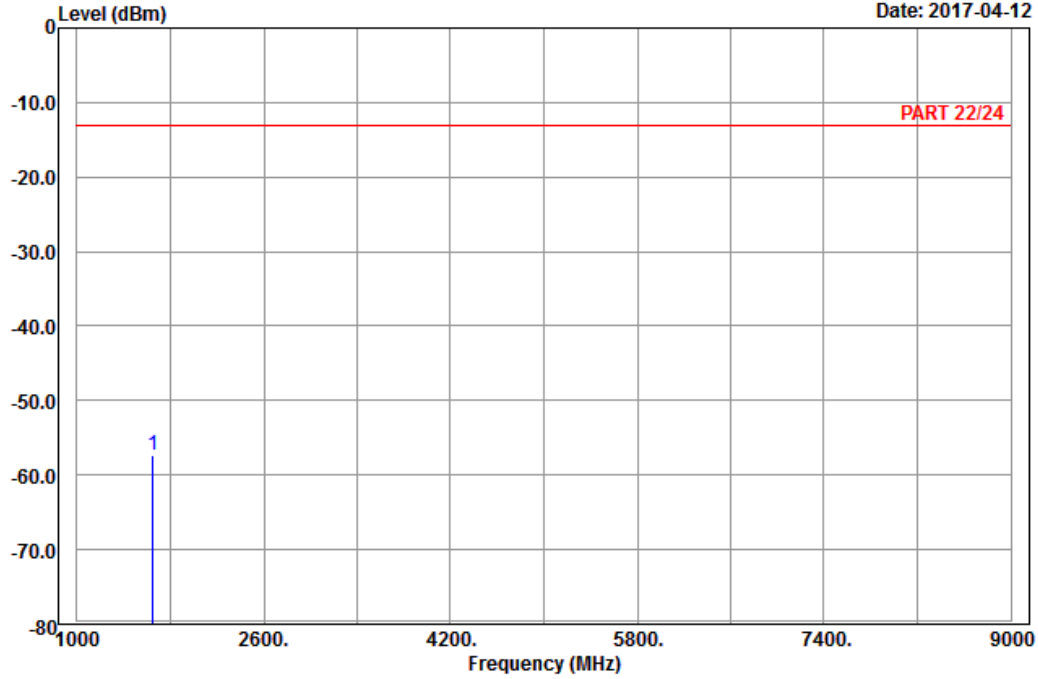

Site : 966 chamber 1
 Condition: PART 22/24 Vertical
 Remark : Band V_Link_CH4132
 Tested by: Charles Hsiao

	Freq	Level	Read Level	Limit Line	Over Limit	Factor	Remark
	MHz	dBm	dBm	dBm	dB	dB	
1	pp 1652.80	-57.36	-65.09	-13.00	-44.36	7.73	Peak

Middle Channel



Bureau Veritas Consumer Products Services Ltd., Taoyuan Branch

A D T

Data: 9

Date: 2017-04-12

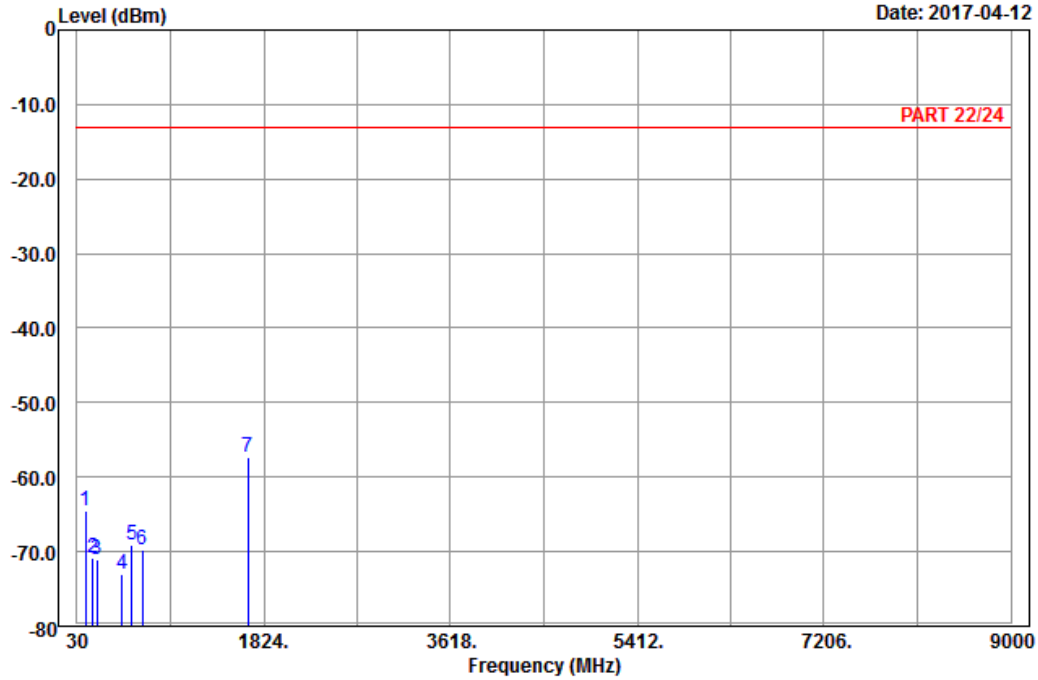

Site : 966 chamber 1
 Condition: PART 22/24 Horizontal
 Remark : Band V_Link_CH4182
 Tested by: Charles Hsiao

	Read	Limit	Over				
Freq	Level	Level	Line	Limit	Factor	Remark	
MHz	dBm	dBm	dBm	dB	dB		
1	113.16	-64.50	-55.81	-13.00	-51.50	-8.69	Peak
2	178.50	-70.77	-64.99	-13.00	-57.77	-5.78	Peak
3	221.70	-71.08	-65.20	-13.00	-58.08	-5.88	Peak
4	462.40	-72.93	-68.72	-13.00	-59.93	-4.21	Peak
5	556.20	-69.00	-67.58	-13.00	-56.00	-1.42	Peak
6	661.20	-69.72	-69.53	-13.00	-56.72	-0.19	Peak
7 pp	1672.80	-57.31	-65.22	-13.00	-44.31	7.91	Peak



Bureau Veritas Consumer Products Services Ltd., Taoyuan Branch

A D T

Data: 10

Date: 2017-04-12

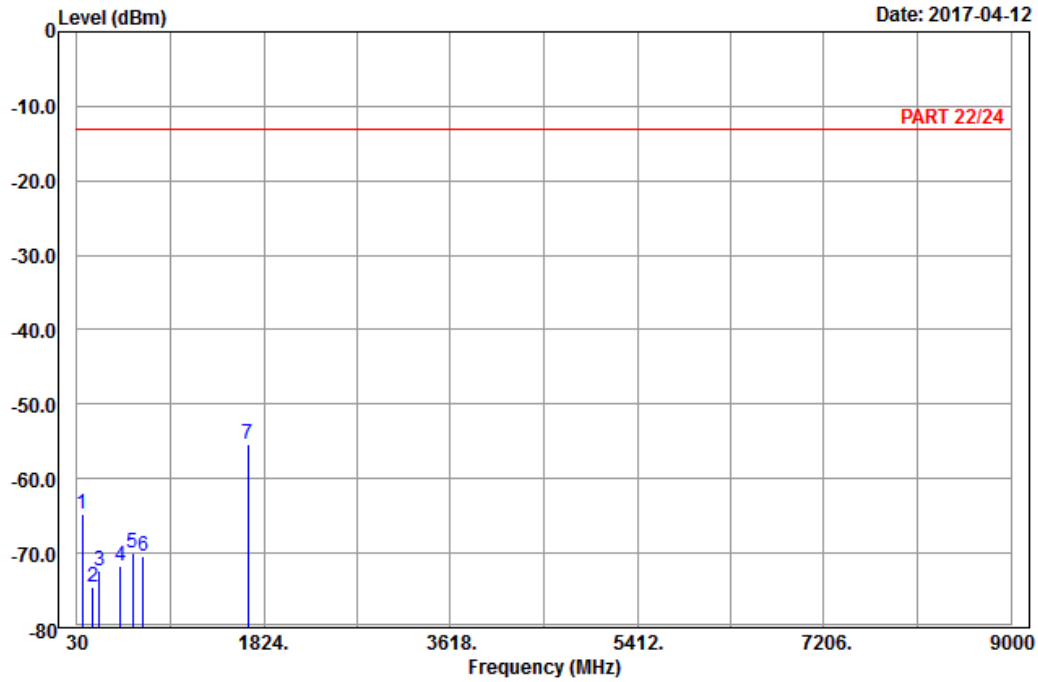

Site : 966 chamber 1
 Condition: PART 22/24 Vertical
 Remark : Band V_Link_CH4182
 Tested by: Charles Hsiao

	Read	Limit	Over				
Freq	Level	Level	Line	Limit	Factor	Remark	
MHz	dBm	dBm	dBm	dB	dB		
1	79.95	-64.78	-52.93	-13.00	-51.78	-11.85	Peak
2	178.77	-74.66	-68.88	-13.00	-61.66	-5.78	Peak
3	241.95	-72.30	-66.69	-13.00	-59.30	-5.61	Peak
4	445.60	-71.73	-67.99	-13.00	-58.73	-3.74	Peak
5	566.00	-70.00	-69.02	-13.00	-57.00	-0.98	Peak
6	667.50	-70.50	-70.28	-13.00	-57.50	-0.22	Peak
7 pp	1672.80	-55.40	-63.31	-13.00	-42.40	7.91	Peak

High Channel



Bureau Veritas Consumer Products Services Ltd., Taoyuan Branch

A D T

Data: 5

Date: 2017-04-12

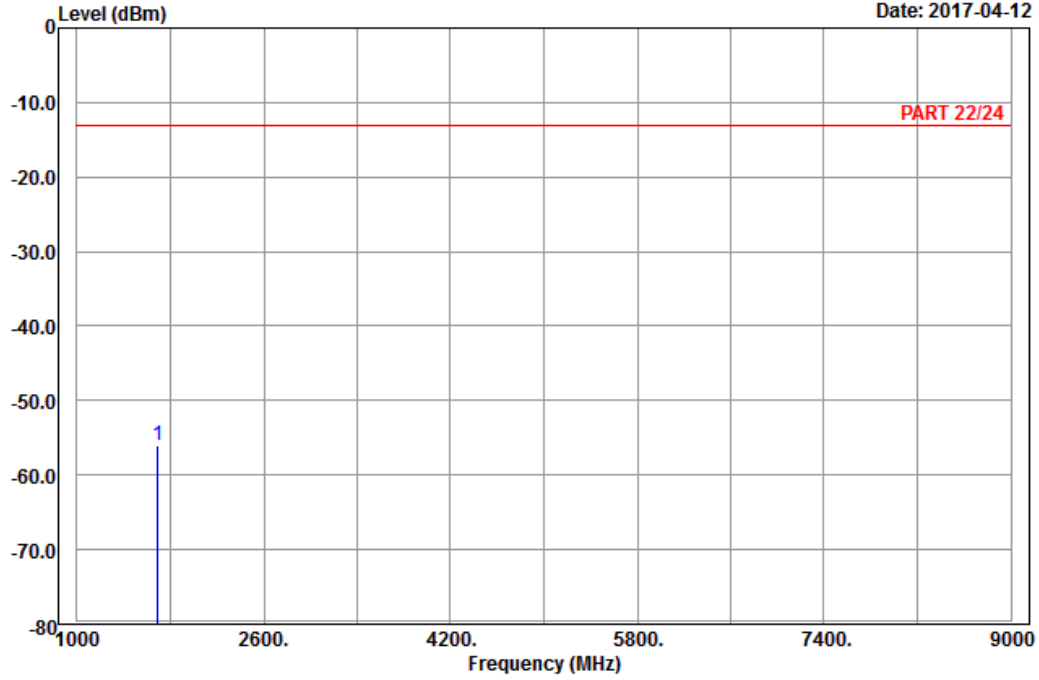

Site : 966 chamber 1
 Condition: PART 22/24 Horizontal
 Remark : Band V_Link_CH4233
 Tested by: Charles Hsiao

Freq	Level	Read Level	Limit	Over	Factor	Remark
MHz	dBm	dBm	dBm	dB	dB	
1 pp 1693.20	-55.92	-64.06	-13.00	-42.92	8.14	Peak



Bureau Veritas Consumer Products Services Ltd., Taoyuan Branch

A D T

Data: 6

Date: 2017-04-12

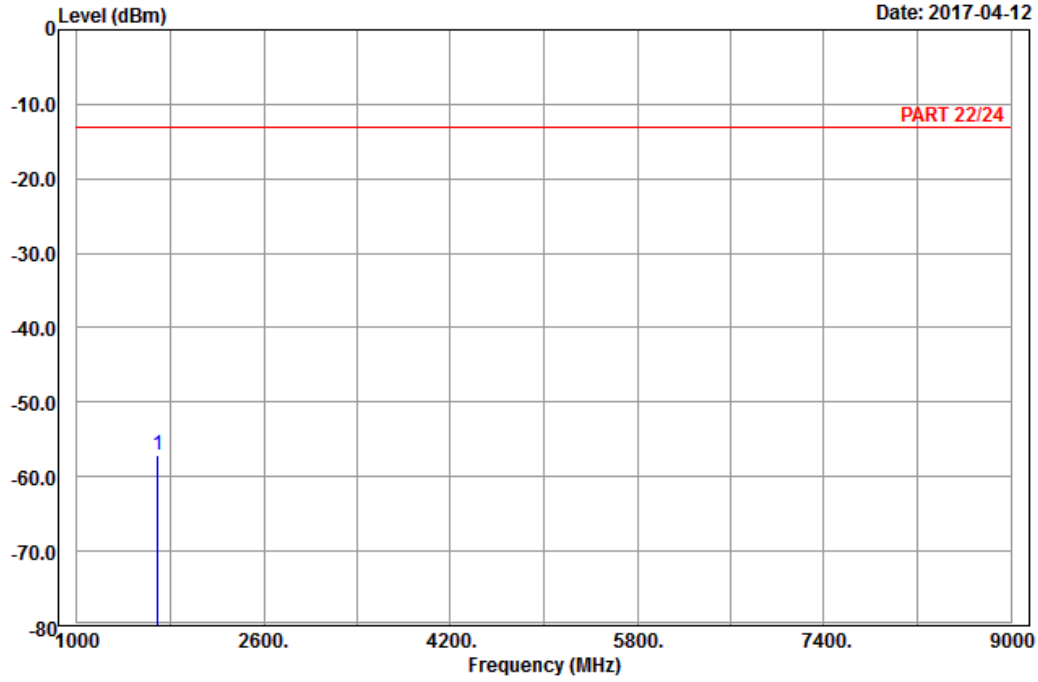

Site : 966 chamber 1
 Condition: PART 22/24 Vertical
 Remark : Band V_Link_CH4233
 Tested by: Charles Hsiao

	Freq	Level	Read Level	Limit Line	Over Limit	Factor	Remark
	MHz	dBm	dBm	dBm	dB	dB	
1 pp	1693.20	-57.12	-65.26	-13.00	-44.12	8.14	Peak

CDMA:
Low Channel



Bureau Veritas Consumer Products Services Ltd., Taoyuan Branch

A D T

Data: 9

Date: 2017-04-12

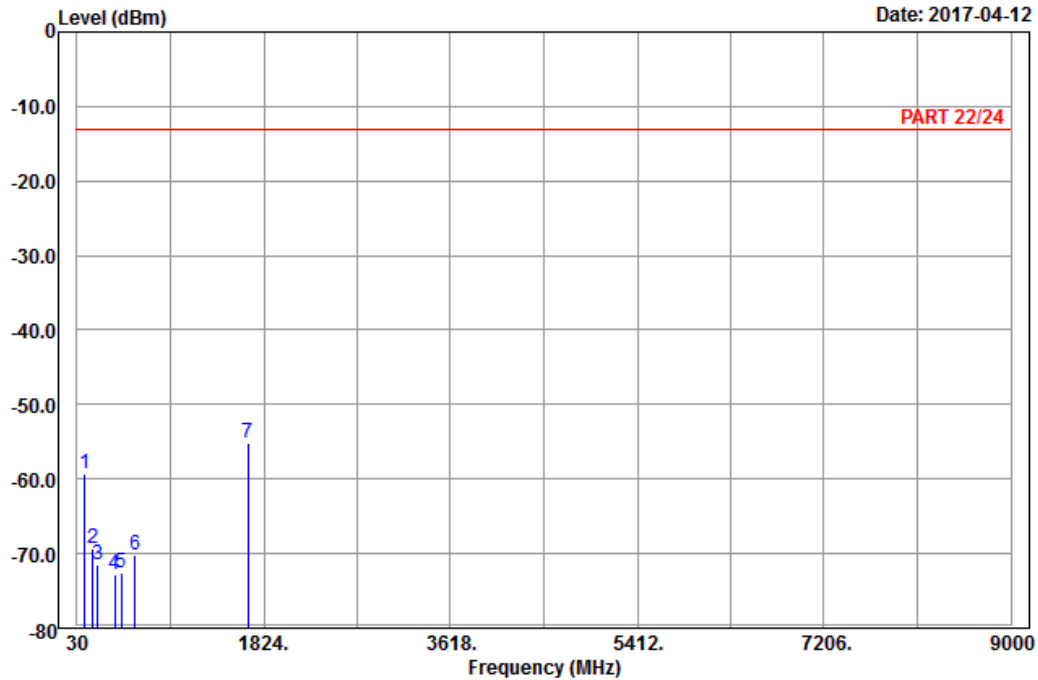

Site : 966 chamber 1
Condition: PART 22/24 Horizontal
Remark : BC 0_Link_CH384
Tested by: Charles Hsiao

	Freq	Level	Read Level	Limit Line	Over Limit	Factor	Remark
	MHz	dBm	dBm	dBm	dB	dB	
1	105.60	-59.38	-49.96	-13.00	-46.38	-9.42	Peak
2	182.82	-69.40	-63.78	-13.00	-56.40	-5.62	Peak
3	231.15	-71.53	-65.76	-13.00	-58.53	-5.77	Peak
4	389.60	-72.77	-69.51	-13.00	-59.77	-3.26	Peak
5	458.90	-72.68	-68.59	-13.00	-59.68	-4.09	Peak
6	584.90	-70.19	-69.97	-13.00	-57.19	-0.22	Peak
7 pp	1673.04	-55.22	-63.13	-13.00	-42.22	7.91	Peak



Bureau Veritas Consumer Products Services Ltd., Taoyuan Branch

A D T

Data: 10

Date: 2017-04-12

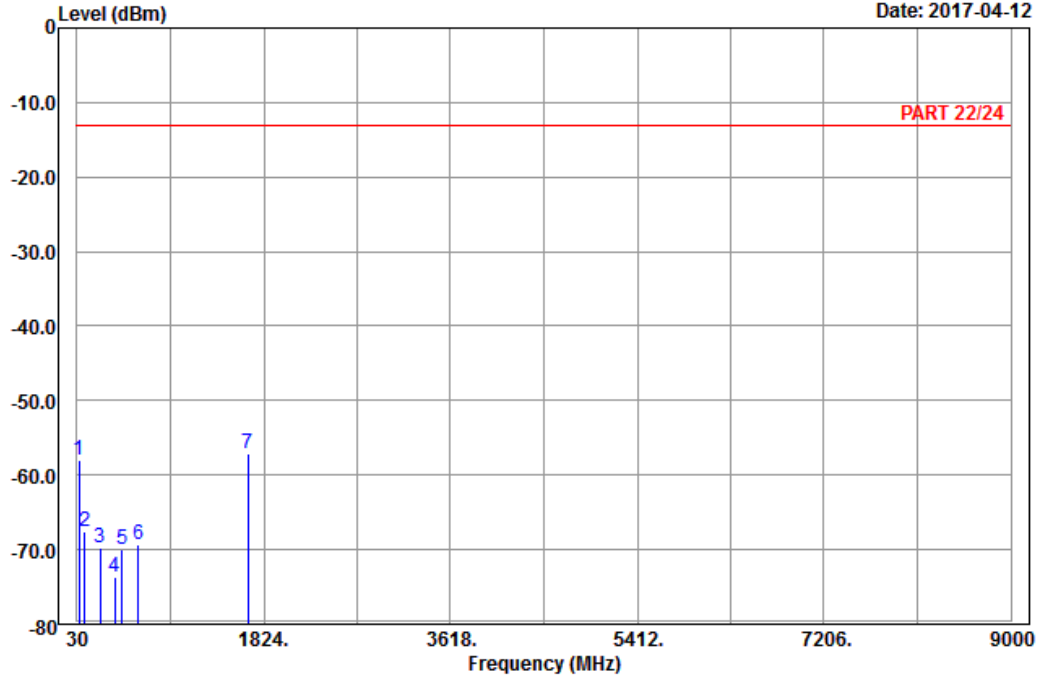

Site : 966 chamber 1
 Condition: PART 22/24 Vertical
 Remark : BC 0_Link_CH384
 Tested by: Charles Hsiao

	Freq	Level	Read Level	Limit Line	Over Limit	Factor	Remark
	MHz	dBm	dBm	dBm	dB	dB	
1	48.09	-58.05	-44.62	-13.00	-45.05	-13.43	Peak
2	106.95	-67.61	-58.31	-13.00	-54.61	-9.30	Peak
3	250.86	-69.82	-64.30	-13.00	-56.82	-5.52	Peak
4	391.70	-73.64	-70.49	-13.00	-60.64	-3.15	Peak
5	461.70	-70.04	-65.86	-13.00	-57.04	-4.18	Peak
6	615.70	-69.40	-69.65	-13.00	-56.40	0.25	Peak
7 pp	1673.04	-57.21	-65.12	-13.00	-44.21	7.91	Peak

Middle Channel



Bureau Veritas Consumer Products Services Ltd., Taoyuan Branch

A D T

Data: 5

Date: 2017-04-12

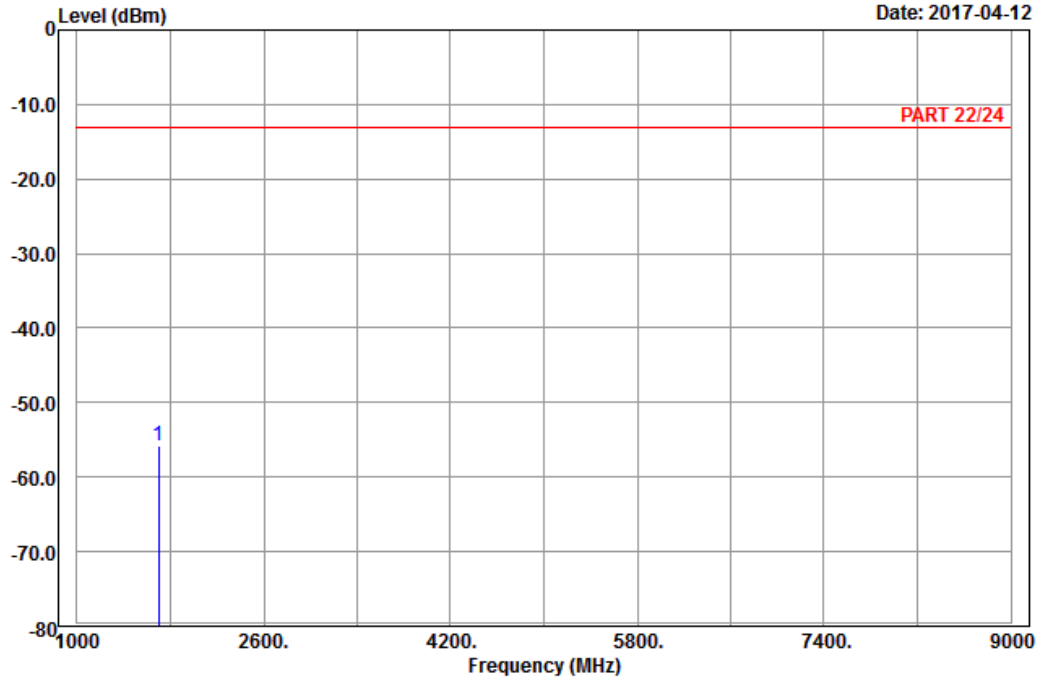

Site : 966 chamber 1
 Condition: PART 22/24 Horizontal
 Remark : BC 0_Link_CH777
 Tested by: Charles Hsiao

	Read	Limit	Over			
Freq	Level	Level	Line	Limit	Factor	Remark
MHz	dBm	dBm	dBm	dB	dB	
1 pp 1696.62	-55.70	-63.84	-13.00	-42.70	8.14	Peak



Bureau Veritas Consumer Products Services Ltd., Taoyuan Branch

A D T

Data: 6

Date: 2017-04-12

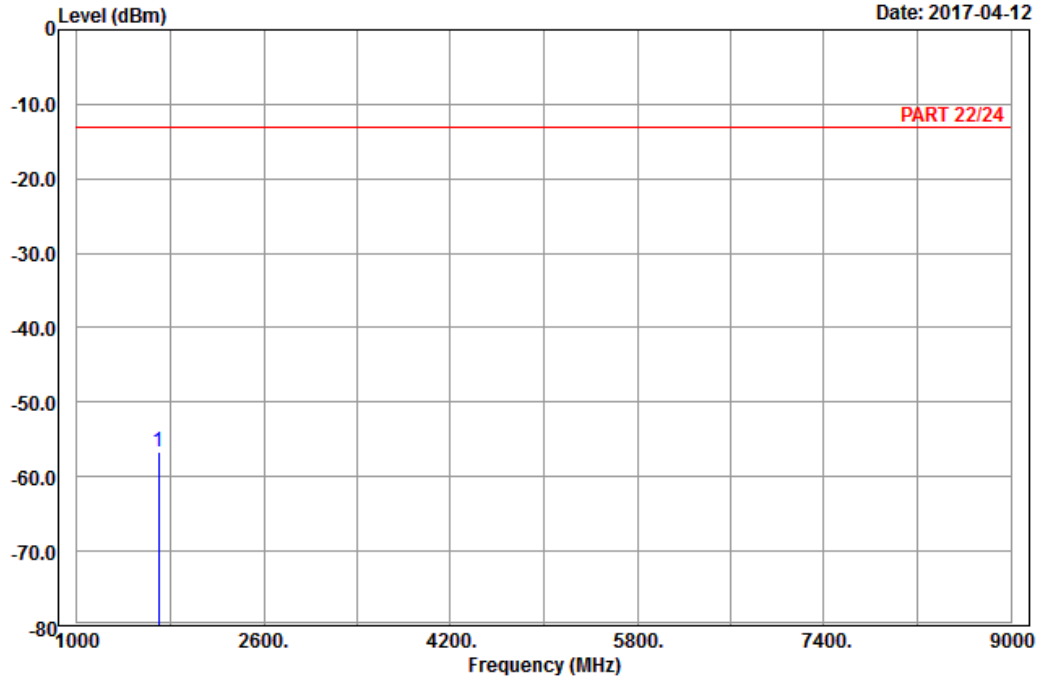

Site : 966 chamber 1
 Condition: PART 22/24 Vertical
 Remark : BC 0_Link_CH777
 Tested by: Charles Hsiao

Freq	Level	Read Level	Limit Line	Over Limit	Factor	Remark
MHz	dBm	dBm	dBm	dB	dB	
1 pp 1696.62	-56.58	-64.72	-13.00	-43.58	8.14	Peak

High Channel



Bureau Veritas Consumer Products Services Ltd., Taoyuan Branch

A D T

Data: 5

Date: 2017-04-12

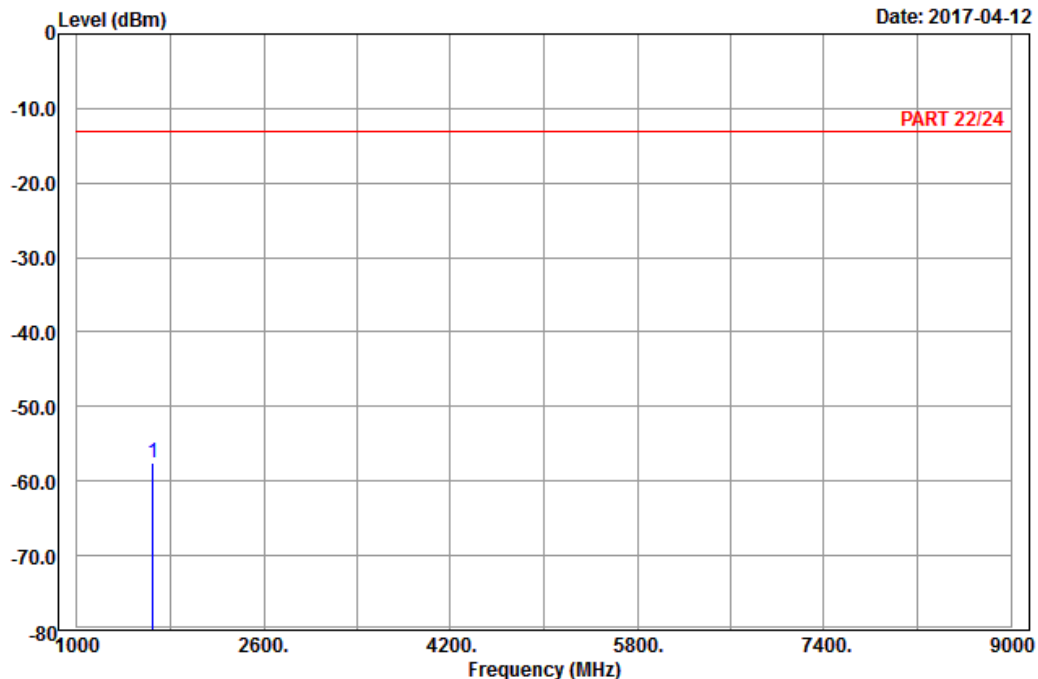

Site : 966 chamber 1
 Condition: PART 22/24 Horizontal
 Remark : BC 0_Link_CH1013
 Tested by: Charles Hsiao

	Read	Limit	Over			
Freq	Level	Level	Line	Limit	Factor	Remark
MHz	dBm	dBm	dBm	dB	dB	
1 pp 1649.40	-57.56	-65.29	-13.00	-44.56	7.73	Peak



A D T

Data: 6

Date: 2017-04-12

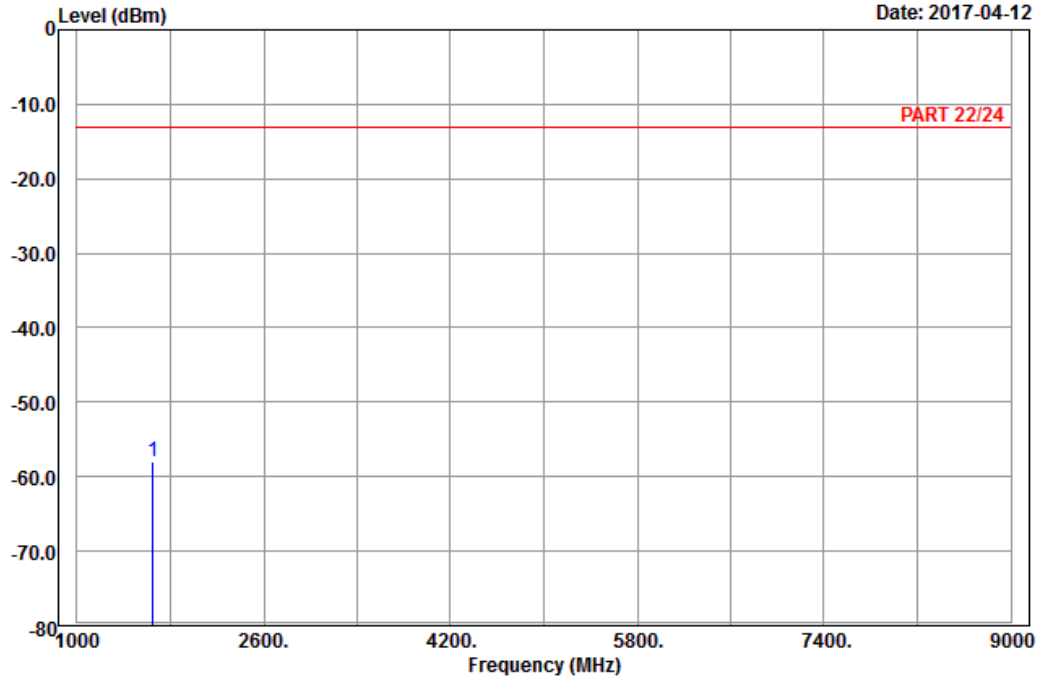

Site : 966 chamber 1
 Condition: PART 22/24 Vertical
 Remark : BC 0_Link_CH1013
 Tested by: Charles Hsiao

	Freq	Level	Read Level	Limit Line	Over Limit	Factor	Remark
	MHz	dBm	dBm	dBm	dB	dB	
1	pp 1649.40	-58.07	-65.80	-13.00	-45.07	7.73	Peak

LTE Band 5
Channel Bandwidth: 10 MHz / QPSK
Low Channel



Bureau Veritas Consumer Products Services Ltd., Taoyuan Branch

A D T

Data: 5

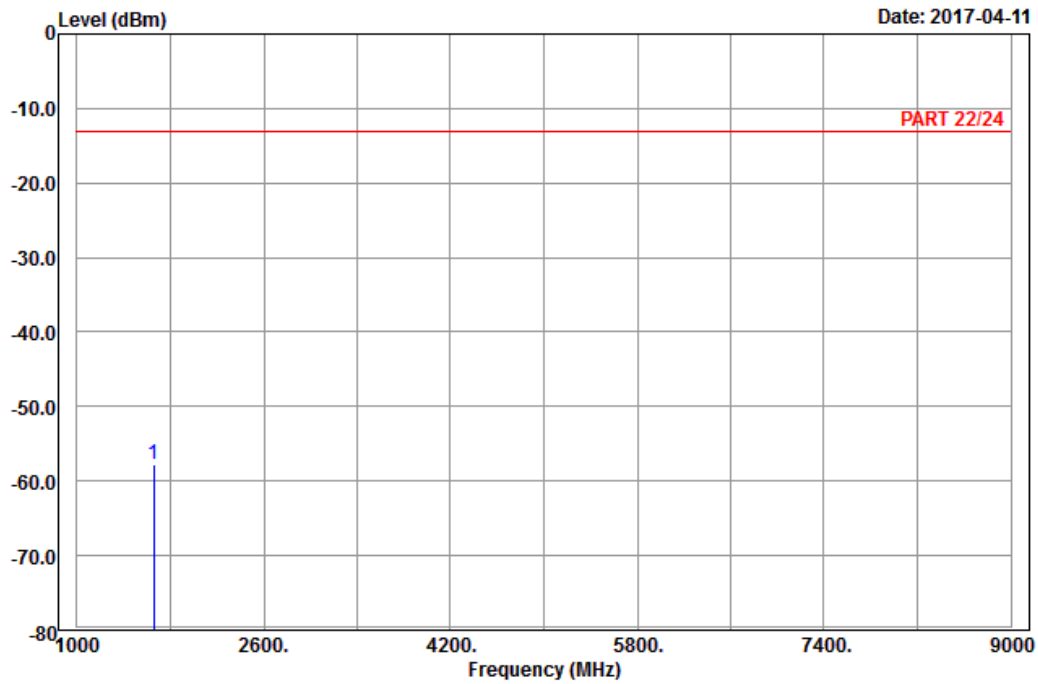

Site : 966 chamber 1
Condition: PART 22/24 Horizontal
Remark : LTE_Band 5_Link_CH20450
Tested by: Karl Lee

	Read	Limit	Over			
Freq	Level	Level	Line	Limit	Factor	Remark
MHz	dBm	dBm	dBm	dB	dB	
1 pp 1658.00	-57.71	-65.62	-13.00	-44.71	7.91	Peak



A D T

Data: 6

Date: 2017-04-11

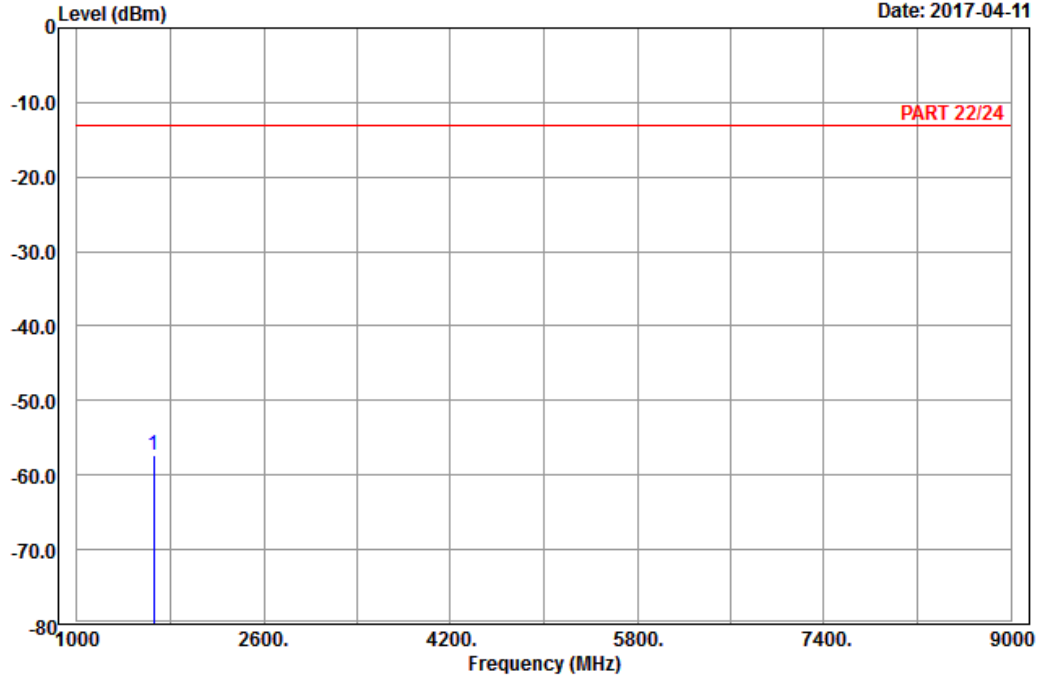

Site : 966 chamber 1
 Condition: PART 22/24 Vertical
 Remark : LTE_Band 5_Link_CH20450
 Tested by: Karl Lee

	Freq	Level	Read Level	Limit Line	Over Limit	Factor	Remark
	MHz	dBm	dBm	dBm	dB	dB	
1	pp 1658.00	-57.32	-65.23	-13.00	-44.32	7.91	Peak

Middle Channel



Bureau Veritas Consumer Products Services Ltd., Taoyuan Branch

A D T

Data: 9

Date: 2017-04-11

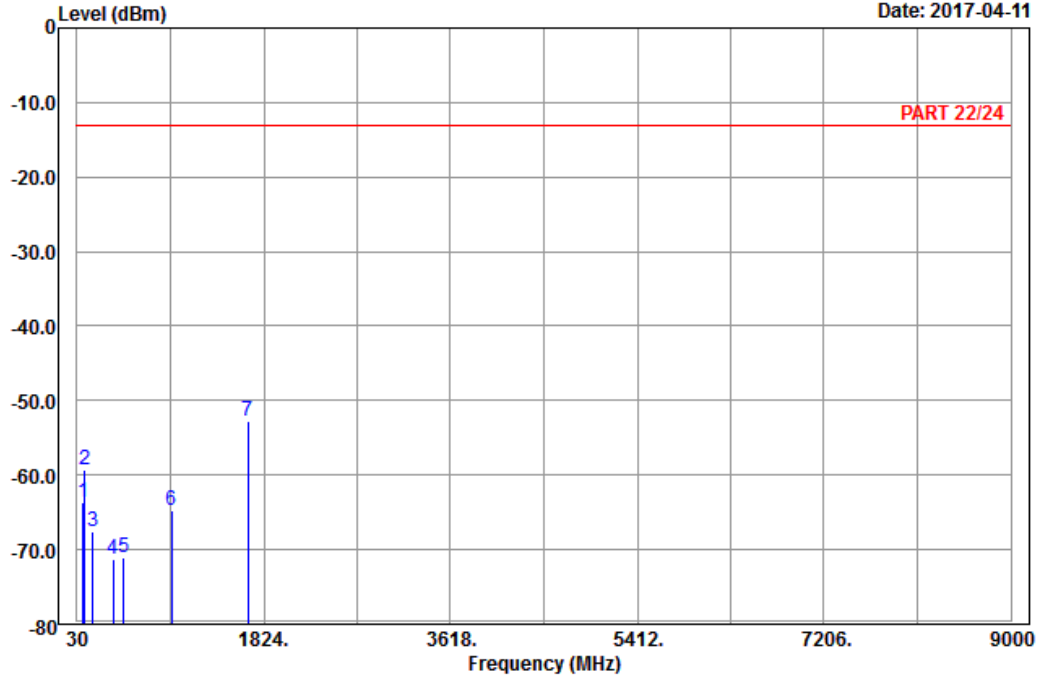

Site : 966 chamber 1
 Condition: PART 22/24 Horizontal
 Remark : LTE_Band 5_Link_CH20525
 Tested by: Karl Lee

	Freq	Level	Read Level	Limit Line	Over Limit	Factor	Remark
	MHz	dBm	dBm	dBm	dB	dB	
1	90.48	-63.75	-53.08	-13.00	-50.75	-10.67	Peak
2	106.14	-59.21	-49.79	-13.00	-46.21	-9.42	Peak
3	180.12	-67.53	-61.95	-13.00	-54.53	-5.58	Peak
4	379.10	-71.19	-67.36	-13.00	-58.19	-3.83	Peak
5	475.00	-71.14	-66.58	-13.00	-58.14	-4.56	Peak
6	939.10	-64.81	-69.44	-13.00	-51.81	4.63	Peak
7 pp	1673.00	-52.70	-60.61	-13.00	-39.70	7.91	Peak



Bureau Veritas Consumer Products Services Ltd., Taoyuan Branch

A D T

Data: 10

Date: 2017-04-11

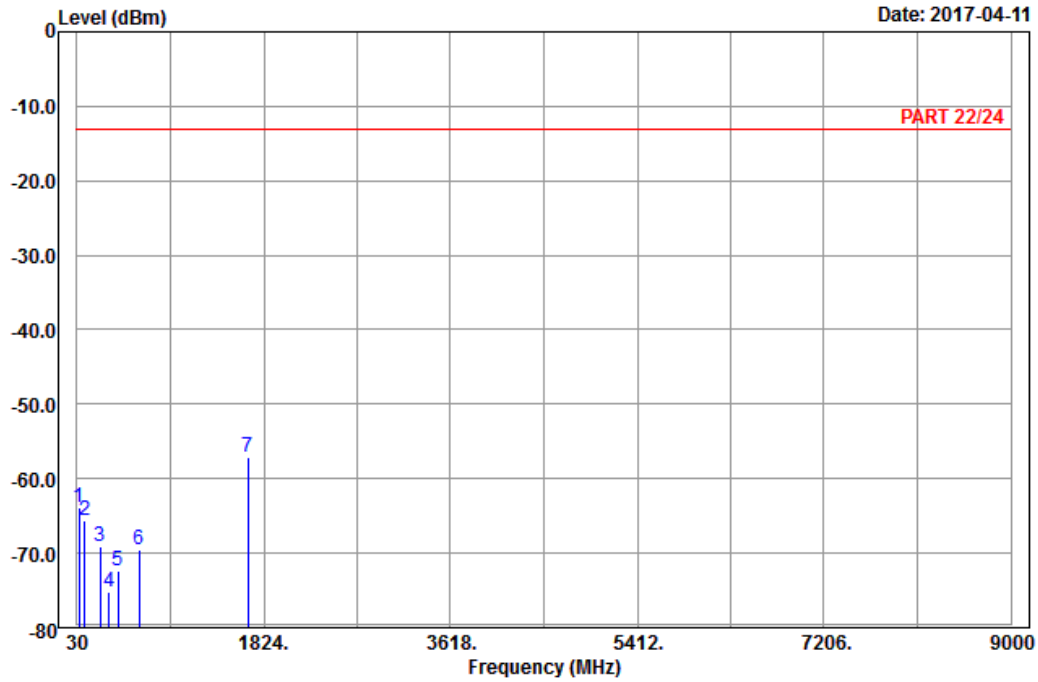

Site : 966 chamber 1
 Condition: PART 22/24 Vertical
 Remark : LTE_Band 5_Link_CH20525
 Tested by: Karl Lee

	Freq	Level	Read Level	Limit Line	Over Limit	Factor	Remark
	MHz	dBm	dBm	dBm	dB	dB	
1	52.68	-63.87	-49.81	-13.00	-50.87	-14.06	Peak
2	105.06	-65.56	-56.03	-13.00	-52.56	-9.53	Peak
3	248.70	-69.17	-63.64	-13.00	-56.17	-5.53	Peak
4	334.30	-75.29	-69.73	-13.00	-62.29	-5.56	Peak
5	425.30	-72.34	-69.03	-13.00	-59.34	-3.31	Peak
6	623.40	-69.50	-69.66	-13.00	-56.50	0.16	Peak
7 pp	1673.00	-57.15	-65.06	-13.00	-44.15	7.91	Peak

High Channel



Bureau Veritas Consumer Products Services Ltd., Taoyuan Branch

A D T

Data: 5

Date: 2017-04-11

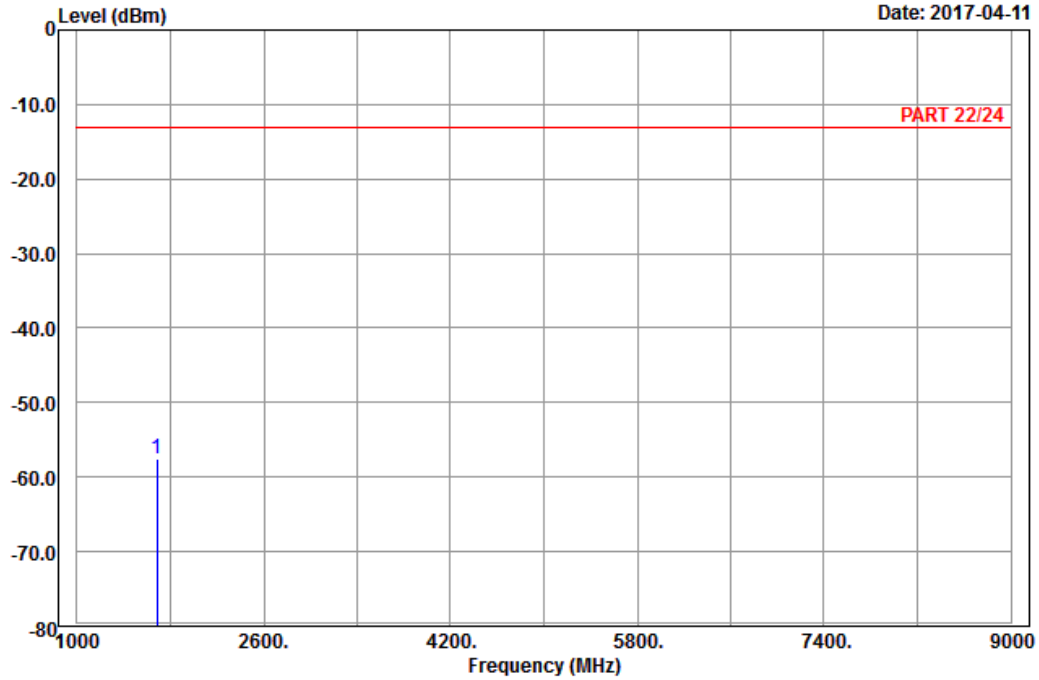

Site : 966 chamber 1
 Condition: PART 22/24 Horizontal
 Remark : LTE_Band 5_Link_CH20600
 Tested by: Karl Lee

	Read	Limit	Over		
Freq	Level	Level	Line	Limit	Factor Remark
MHz	dBm	dBm	dBm	dB	dB
1 pp 1688.00	-57.54	-65.56	-13.00	-44.54	8.02 Peak



Bureau Veritas Consumer Products Services Ltd., Taoyuan Branch

A D T

Data: 6

Date: 2017-04-11

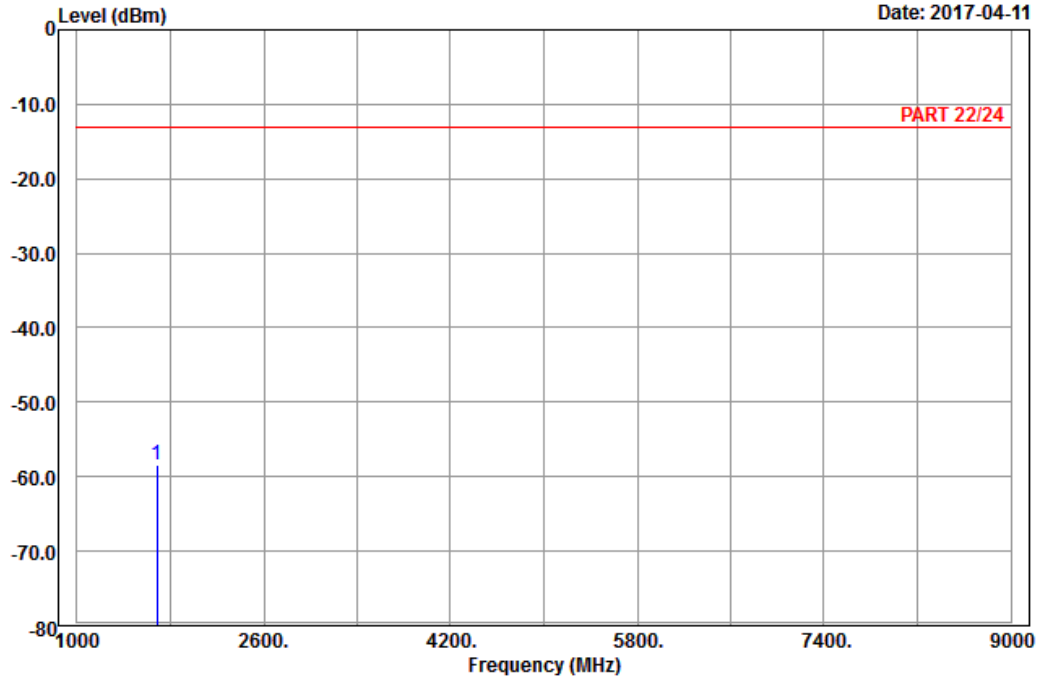

Site : 966 chamber 1
 Condition: PART 22/24 Vertical
 Remark : LTE_Band 5_Link_CH20600
 Tested by: Karl Lee

	Freq	Level	Read Level	Limit Line	Over Limit	Factor	Remark
	MHz	dBm	dBm	dBm	dB	dB	
1 pp	1688.00	-58.47	-66.49	-13.00	-45.47	8.02	Peak

LTE Band 26
Channel Bandwidth: 15 MHz / QPSK
Low Channel



Bureau Veritas Consumer Products Services Ltd., Taoyuan Branch

A D T

Data: 5

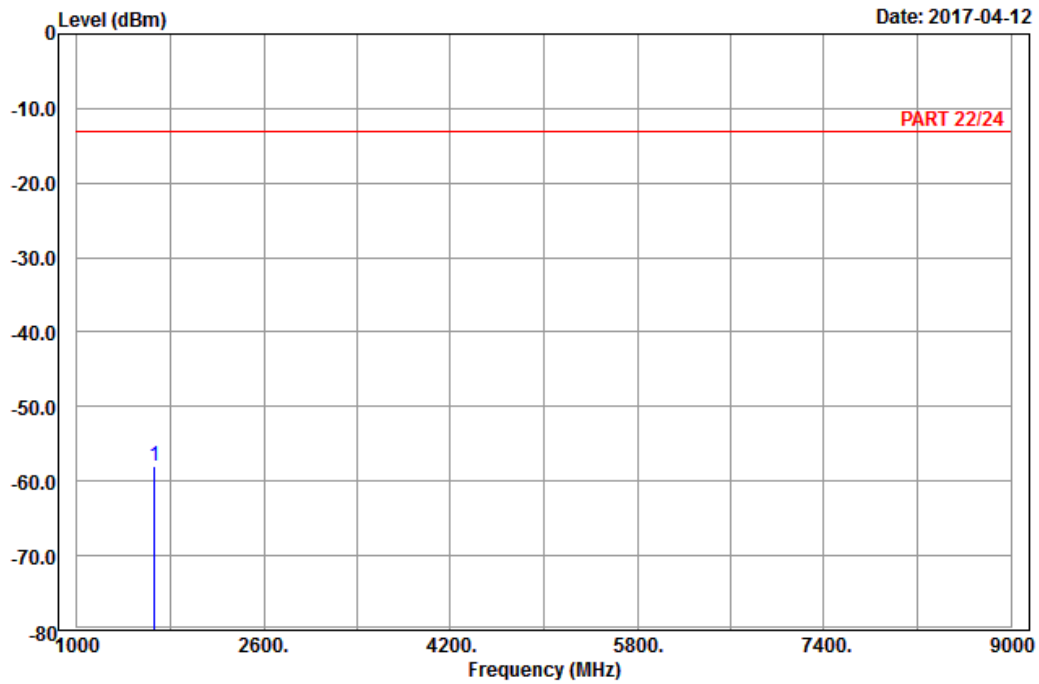

Site : 966 chamber 1
Condition: PART 22/24 Horizontal
Remark : LTE_Band 26_Link_CH26865
Tested by: Chalres Hsiao

	Read	Limit	Over			
Freq	Level	Level	Line	Limit	Factor	Remark
MHz	dBm	dBm	dBm	dB	dB	
1 pp 1663.00	-58.01	-65.92	-13.00	-45.01	7.91	Peak



A D T

Data: 6

Date: 2017-04-12

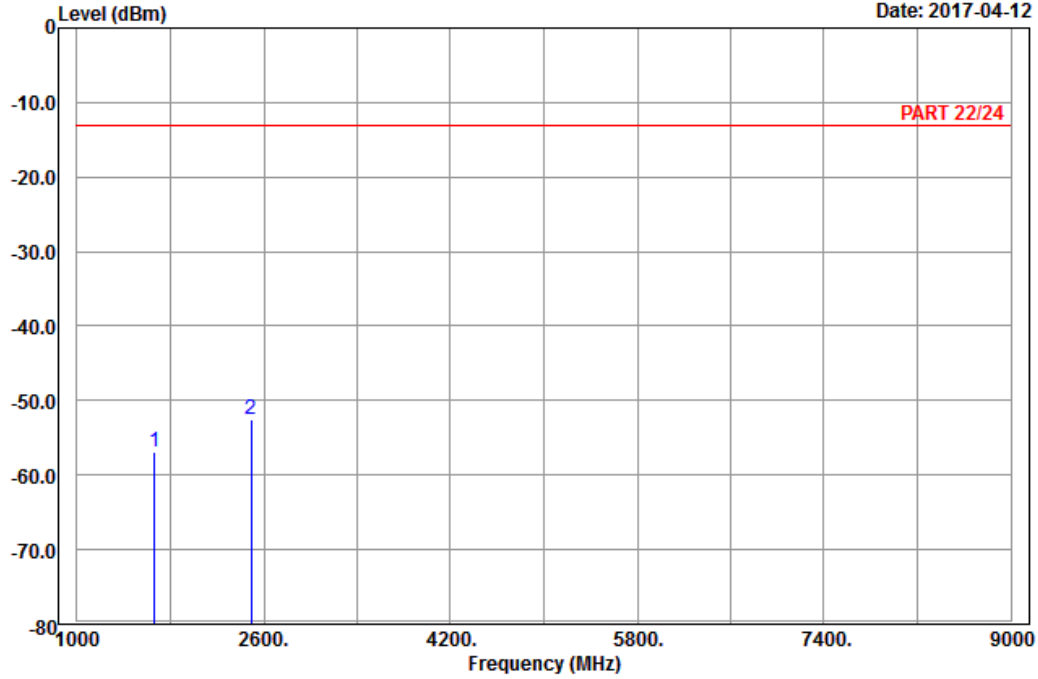

Site : 966 chamber 1
 Condition: PART 22/24 Vertical
 Remark : LTE_Band 26_Link_CH26865
 Tested by: Chalres Hsiao

	Freq	Level	Read Level	Limit Line	Over Limit	Factor	Remark
	MHz	dBm	dBm	dBm	dB	dB	
1	1663.00	-56.80	-64.71	-13.00	-43.80	7.91	Peak
2 pp	2494.50	-52.57	-63.61	-13.00	-39.57	11.04	Peak

Middle Channel



Bureau Veritas Consumer Products Services Ltd., Taoyuan Branch

A D T

Data: 5

Date: 2017-04-12

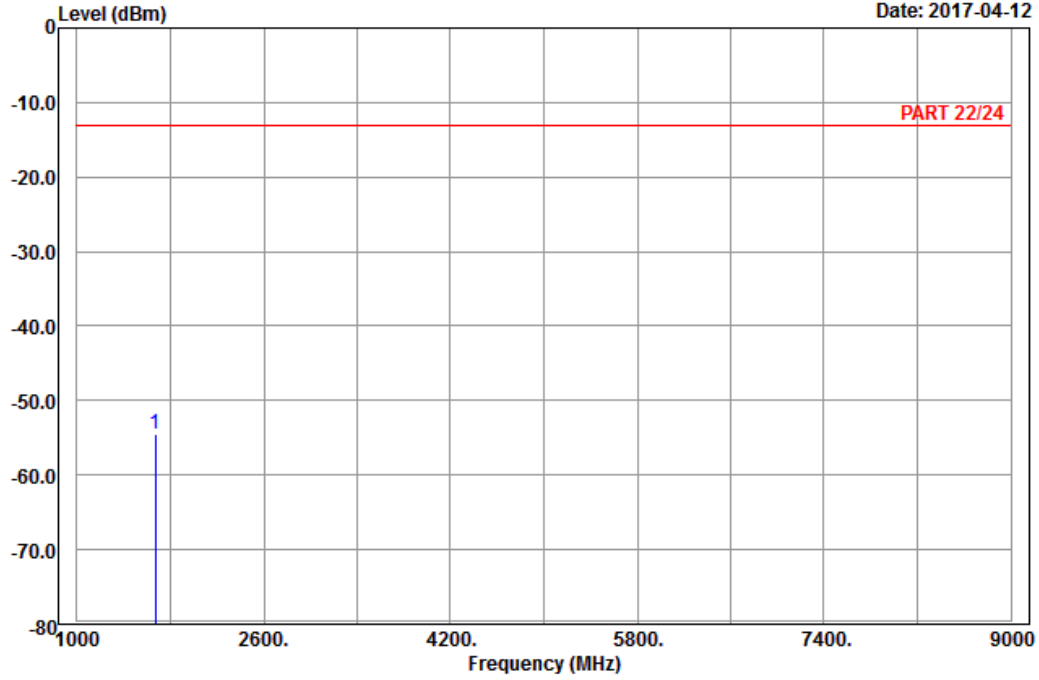

Site : 966 chamber 1
 Condition: PART 22/24 Horizontal
 Remark : LTE_Band 26_Link_CH26915
 Tested by: Chalres Hsiao

Freq	Level	Read Level	Limit	Over	Factor	Remark
MHz	dBm	dBm	dBm	dB	dB	
1 pp 1673.00	-54.40	-62.31	-13.00	-41.40	7.91	Peak



Bureau Veritas Consumer Products Services Ltd., Taoyuan Branch

A D T

Data: 6

Date: 2017-04-12

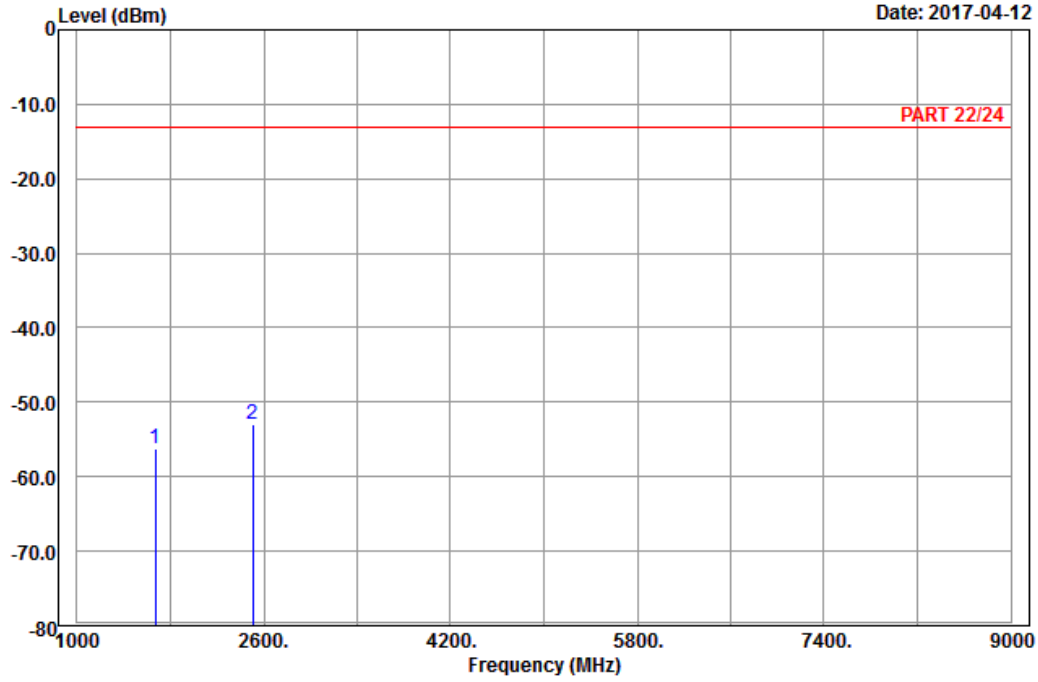

Site : 966 chamber 1
 Condition: PART 22/24 Vertical
 Remark : LTE_Band 26_Link_CH26915
 Tested by: Chalres Hsiao

	Freq	Level	Read Level	Limit Line	Over Limit	Factor	Remark
	MHz	dBm	dBm	dBm	dB	dB	
1	1673.00	-56.27	-64.18	-13.00	-43.27	7.91	Peak
2 pp	2509.50	-53.07	-64.35	-13.00	-40.07	11.28	Peak

High Channel



Bureau Veritas Consumer Products Services Ltd., Taoyuan Branch

A D T

Data: 9

Date: 2017-04-12

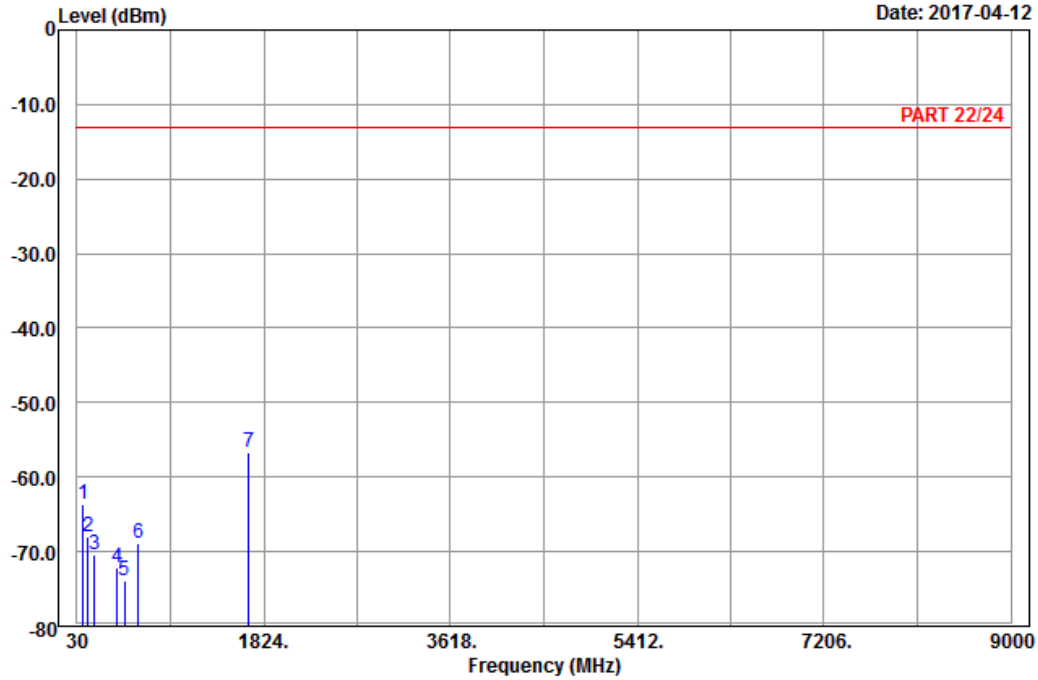

Site : 966 chamber 1
 Condition: PART 22/24 Horizontal
 Remark : LTE_Band 26_Link_CH26965
 Tested by: Chalres Hsiao

	Read	Limit	Over				
Freq	Level	Level	Line	Limit	Factor	Remark	
MHz	dBm	dBm	dBm	dB	dB		
1	90.48	-63.75	-53.08	-13.00	-50.75	-10.67	Peak
2	131.52	-68.06	-60.40	-13.00	-55.06	-7.66	Peak
3	198.21	-70.42	-64.33	-13.00	-57.42	-6.09	Peak
4	419.00	-72.13	-68.96	-13.00	-59.13	-3.17	Peak
5	487.60	-73.83	-68.91	-13.00	-60.83	-4.92	Peak
6	622.00	-68.93	-69.11	-13.00	-55.93	0.18	Peak
7 pp	1683.00	-56.78	-64.80	-13.00	-43.78	8.02	Peak



Bureau Veritas Consumer Products Services Ltd., Taoyuan Branch

A D T

Data: 10

Date: 2017-04-12

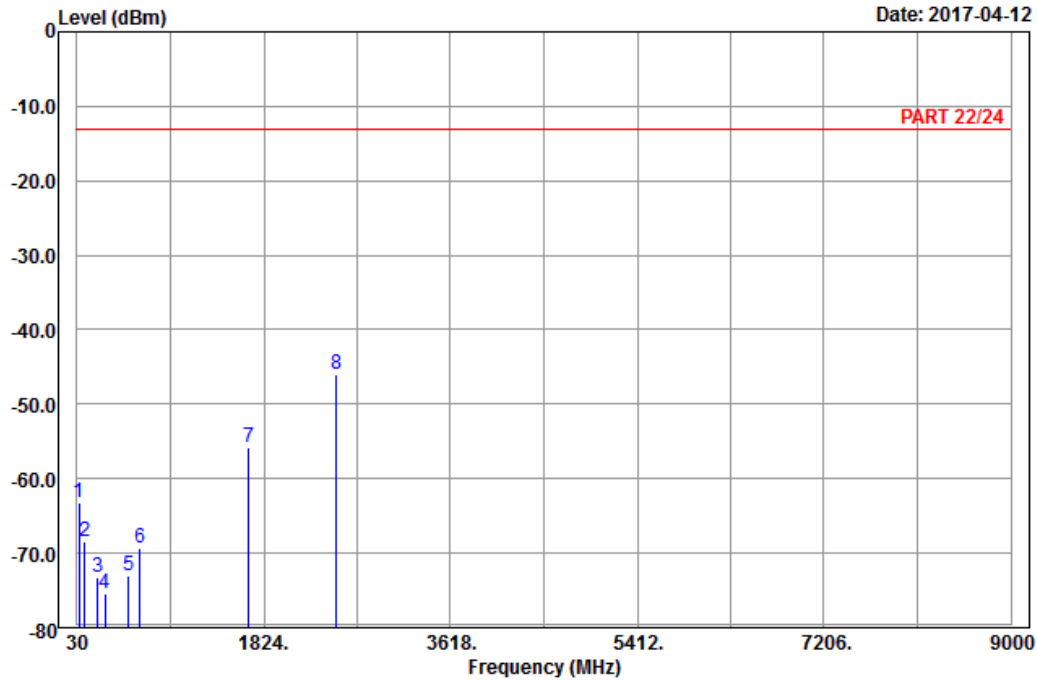

Site : 966 chamber 1
 Condition: PART 22/24 Vertical
 Remark : LTE_Band 26_Link_CH26965
 Tested by: Chalres Hsiao

	Read	Limit	Over			Remark
Freq	Level	Level	Line	Limit	Factor	
MHz	dBm	dBm	dBm	dB	dB	
1	52.14	-63.28	-49.22	-13.00	-50.28	-14.06 Peak
2	100.20	-68.38	-58.26	-13.00	-55.38	-10.12 Peak
3	230.07	-73.18	-67.40	-13.00	-60.18	-5.78 Peak
4	301.40	-75.36	-69.42	-13.00	-62.36	-5.94 Peak
5	521.90	-73.03	-69.31	-13.00	-60.03	-3.72 Peak
6	636.70	-69.34	-69.36	-13.00	-56.34	0.02 Peak
7	1683.00	-55.90	-63.92	-13.00	-42.90	8.02 Peak
8 pp	2524.50	-45.90	-57.28	-13.00	-32.90	11.38 Peak

5 Pictures of Test Arrangements

Please refer to the attached file (Test Setup Photo).

Appendix – Information on the Testing Laboratories

We, Bureau Veritas Consumer Products Services (H.K.) Ltd., Taoyuan Branch, were founded in 1988 to provide our best service in EMC, Radio, Telecom and Safety consultation. Our laboratories are accredited and approved according to ISO/IEC 17025.

If you have any comments, please feel free to contact us at the following:

Linko EMC/RF Lab

Tel: 886-2-26052180

Fax: 886-2-26051924

Hsin Chu EMC/RF/Telecom Lab

Tel: 886-3-6668565

Fax: 886-3-6668323

Hwa Ya EMC/RF/Safety

Tel: 886-3-3183232

Fax: 886-3-3270892

Email: service.adt@tw.bureauveritas.com

Web Site: www.bureauveritas-adt.com

The address and road map of all our labs can be found in our web site also.

--- END ---