



FCC TEST REPORT (15.407)

REPORT NO.: RF150707C10-3
MODEL NO.: E4710
FCC ID: V65E4710
RECEIVED: Jul. 07, 2015
TESTED: Jul. 21, 2015 ~ Jul. 29, 2015
ISSUED: Aug. 06, 2015

APPLICANT: Kyocera Corporation c/o Kyocera Communications, Inc.
ADDRESS: 9520 Towne Centre Drive, Suite 200, San Diego, CA 92121

ISSUED BY: Bureau Veritas Consumer Products Services
(H.K.) Ltd., Taoyuan Branch

LAB ADDRESS: No. 47-2, 14th Ling, Chia Pau Vil., Lin Kou Dist.,
New Taipei City, Taiwan (R.O.C)

TEST LOCATION (1): No. 19, Hwa Ya 2nd Rd, Wen Hwa Tsuen, Kwei
Shan Hsiang, Taoyuan Hsien 333, Taiwan, R.O.C.

TEST LOCATION (2): No.215, Sec. 3, Beixin Rd., Xindian Dist., New
Taipei City 231, Taiwan, R.O.C

This report should not be used by the client to claim product certification, approval, or endorsement by TAF or any government agencies.



This report is for your exclusive use. Any copying or replication of this report to or for any other person or entity, or use of our name or trademark, is permitted only with our prior written permission. This report sets forth our findings solely with respect to the test samples identified herein. The results set forth in this report are not indicative or representative of the quality or characteristics of the lot from which a test sample was taken or any similar or identical product unless specifically and expressly noted. Our report includes all of the tests requested by you and the results thereof based upon the information that you provided to us. You have 60 days from date of issuance of this report to notify us of any material error or omission caused by our negligence, provided, however, that such notice shall be in writing and shall specifically address the issue you wish to raise. A failure to raise such issue within the prescribed time shall constitute your unqualified acceptance of the completeness of this report, the tests conducted and the correctness of the report contents. Unless specific mention, the uncertainty of measurement has been explicitly taken into account to declare the compliance or non-compliance to the specification.



TABLE OF CONTENTS

RELEASE CONTROL RECORD	4
1. CERTIFICATION.....	5
2. SUMMARY OF TEST RESULTS	6
2.1 MEASUREMENT UNCERTAINTY	6
3. GENERAL INFORMATION.....	7
3.1 GENERAL DESCRIPTION OF EUT.....	7
3.2 DESCRIPTION OF TEST MODES.....	8
3.2.1 TEST MODE APPLICABILITY AND TESTED CHANNEL DETAIL.....	10
3.3 DESCRIPTION OF SUPPORT UNITS.....	13
3.3.1 CONFIGURATION OF SYSTEM UNDER TEST	13
3.4 DUTY CYCLE TEST SIGNAL.....	14
3.5 GENERAL DESCRIPTION OF APPLIED STANDARDS.....	18
4. TEST TYPES AND RESULTS	19
4.1 RADIATED EMISSION AND BANDEDGE MEASUREMENT	19
4.1.1 LIMITS OF RADIATED EMISSION AND BANDEDGE MEASUREMENT.....	19
4.1.2 LIMITS OF UNWANTED EMISSION OUT OF THE RESTRICTED BANDS	19
4.1.3 TEST INSTRUMENTS.....	20
4.1.4 TEST PROCEDURES	21
4.1.5 DEVIATION FROM TEST STANDARD	21
4.1.6 TEST SETUP.....	22
4.1.7 EUT OPERATING CONDITIONS	22
4.1.8 TEST RESULTS.....	23
4.2 CONDUCTED EMISSION MEASUREMENT	60
4.2.1 LIMITS OF CONDUCTED EMISSION MEASUREMENT	60
4.2.2 TEST INSTRUMENTS.....	60
4.2.3 TEST PROCEDURES	61
4.2.4 DEVIATION FROM TEST STANDARD	61
4.2.5 TEST SETUP.....	62
4.2.6 EUT OPERATING CONDITIONS	62
4.2.7 TEST RESULTS.....	63
4.3 TRANSMIT POWER MEASUREMENT.....	65
4.3.1 LIMITS OF TRANSMIT POWER MEASUREMENT	65
4.3.2 TEST SETUP.....	65
4.3.3 TEST INSTRUMENTS.....	66
4.3.4 TEST PROCEDURE.....	66
4.3.5 DEVIATION FROM TEST STANDARD	66
4.3.6 EUT OPERATING CONDITIONS	66
4.3.7 TEST RESULTS.....	67
4.4 PEAK POWER SPECTRAL DENSITY MEASUREMENT.....	72
4.4.1 LIMITS OF PEAK POWER SPECTRAL DENSITY MEASUREMENT	72
4.4.2 TEST SETUP.....	72
4.4.3 TEST INSTRUMENTS.....	72
4.4.4 TEST PROCEDURES	73
4.4.5 DEVIATION FROM TEST STANDARD	73
4.4.6 EUT OPERATING CONDITIONS	73
4.4.7 TEST RESULTS.....	74
4.5 FREQUENCY STABILITY	78
4.5.1 LIMITS OF FREQUENCY STABILITY MEASUREMENT.....	78
4.5.2 TEST SETUP.....	78
4.5.3 TEST INSTRUMENTS.....	78
4.5.4 TEST PROCEDURE.....	79
4.5.5 DEVIATION FROM TEST STANDARD	79



A D T

4.5.6	EUT OPERATING CONDITION.....	79
4.5.7	TEST RESULTS.....	80
4.6	6dB BANDWIDTH MEASUREMENT	81
4.6.1	LIMITS OF 6dB BANDWIDTH MEASUREMENT	81
4.6.2	TEST SETUP	81
4.6.3	TEST INSTRUMENTS	81
4.6.4	TEST PROCEDURE	81
4.6.5	DEVIATION FROM TEST STANDARD	81
4.6.6	EUT OPERATING CONDITIONS	81
4.6.7	TEST RESULTS.....	82
5.	PHOTOGRAPHS OF THE TEST CONFIGURATION.....	84
6.	INFORMATION ON THE TESTING LABORATORIES	85
7.	APPENDIX A - MODIFICATIONS RECORDERS FOR ENGINEERING CHANGES TO THE EUT BY THE LAB	86



A D T

RELEASE CONTROL RECORD

ISSUE NO.	REASON FOR CHANGE	DATE ISSUED
RF150707C10-3	Original release	Aug. 06, 2015



1. CERTIFICATION

PRODUCT: Clamshell phone
MODEL NO.: E4710
BRAND: Kyocera
APPLICANT: Kyocera Corporation c/o Kyocera Communications, Inc.
TESTED: Jul. 21, 2015 ~ Jul. 29, 2015
TEST SAMPLE: Identical Prototype
STANDARDS: **FCC Part 15, Subpart E (Section 15.407)**
ANSI C63.10-2013

The above equipment (model: E4710) has been tested by **Bureau Veritas Consumer Products Services (H.K.) Ltd., Taoyuan Branch**, and found compliance with the requirement of the above standards. The test record, data evaluation & Equipment Under Test (EUT) configurations represented herein are true and accurate accounts of the measurements of the sample's EMC characteristics under the conditions specified in this report.

PREPARED BY : Ivonne Wu , **DATE** : Aug. 06, 2015
Ivonne Wu / Supervisor

APPROVED BY : Kay Wu , **DATE** : Aug. 06, 2015
Kay Wu / Supervisor

2. SUMMARY OF TEST RESULTS

The EUT has been tested according to the following specifications:

APPLIED STANDARD: FCC PART 15, SUBPART E (SECTION 15.407)			
STANDARD SECTION	TEST TYPE	RESULT	REMARK
15.407(b)(6)	AC Power Conducted Emission	PASS	Meet the requirement of limit. Minimum passing margin is -12.03dB at 5.36200MHz.
15.407(b/1/2/3) (b)(6)	Radiated Emissions	PASS	Meet the requirement of limit. Minimum passing margin is -3.37dB at 54.57MHz.
15.407(a/1/2/3)	Max Average Transmit Power	PASS	Meet the requirement of limit.
15.407(a/1/2/3)	Peak Power Spectral Density	PASS	Meet the requirement of limit.
15.407(e)	6dB bandwidth	PASS	Meet the requirement of limit. (U-NII-3 Band only)
15.407(g)	Frequency Stability	PASS	Meet the requirement of limit.
15.203	Antenna Requirement	PASS	No antenna connector is used.

2.1 MEASUREMENT UNCERTAINTY

Where relevant, the following measurement uncertainty levels have been estimated for tests performed on the EUT as specified in CISPR 16-4-2:

MEASUREMENT	FREQUENCY	UNCERTAINTY
Conducted emissions	9kHz~30MHz	2.44 dB
Radiated emissions	30MHz ~ 200MHz	2.01 dB
	200MHz ~1000MHz	2.02 dB
	1GHz ~ 18GHz	1.01 dB
	18GHz ~ 40GHz	1.15 dB

This uncertainty represents an expanded uncertainty expressed at approximately the 95% confidence level using a coverage factor of $k = 2$.

3. GENERAL INFORMATION

3.1 GENERAL DESCRIPTION OF EUT

EUT	Clamshell phone
MODEL NO.	E4710
POWER SUPPLY	5.0Vdc (adapter or host equipment) 3.7Vdc (Li-ion battery)
MODULATION TYPE	64QAM, 16QAM, QPSK, BPSK
MODULATION TECHNOLOGY	OFDM
TRANSFER RATE	802.11a: 54.0/ 48.0/ 36.0/ 24.0/ 18.0/ 12.0/ 9.0/ 6.0Mbps 802.11n: up to MCS7
OPERATING FREQUENCY	5180 ~ 5240MHz, 5260 ~ 5320MHz, 5500 ~ 5700MHz, 5745 ~ 5825MHz
NUMBER OF CHANNEL	5180 ~ 5240MHz: 4 for 802.11a, 802.11n (20MHz) 2 for 802.11n (40MHz) 5260 ~ 5320MHz: 4 for 802.11a, 802.11n (20MHz) 2 for 802.11n (40MHz) 5500 ~ 5700MHz: 11 for 802.11a, 802.11n (20MHz) 5 for 802.11n (40MHz) 5745 ~ 5825MHz: 5 for 802.11a, 802.11n (20MHz) 2 for 802.11n (40MHz)
OUTPUT POWER	21.93mW for 5180 ~ 5240MHz 22.39mW for 5260 ~ 5320MHz 21.63mW for 5500 ~ 5700MHz 21.18mW for 5745 ~ 5825MHz
ANTENNA TYPE	Mono Pole antenna with -3.5dBi gain (5180 ~ 5240MHz) Mono Pole antenna with -3.5dBi gain (5260 ~ 5320MHz) Mono Pole antenna with -3.5dBi gain (5500 ~ 5700MHz) Mono Pole antenna with -3.5dBi gain (5745 ~ 5825MHz)
ANTENNA CONNECTOR	NA
DATA CABLE	Refer to Note as below
I/O PORTS	Refer to user's manual
ACCESSORY DEVICES	Refer to Note as below

NOTE:

- The EUT contains following accessory devices.

ITEM	BRAND	MODEL	SPECIFICATION
Adapter	KYOCERA	SCP-47ADT	I/P: 100-240Vac, 50/60Hz, 0.2A O/P: 5Vdc, 1.0A
Battery	KYOCERA	SCP-63LBPS	3.7Vdc, 1530mAh
Earphone	GALIEN	HF-HB05D	1.3m non-shielded cable w/o core
USB Cable	KYOCERA	SCP-17SDC	1.0m shielded cable w/o core

- The above EUT information is declared by the manufacturer and for more detailed features description, please refer to the manufacturer's specifications or User's Manual.



A D T

3.2 DESCRIPTION OF TEST MODES

WLAN 5180 ~ 5240MHz

4 channels are provided for 802.11a, 802.11n (20MHz):

CHANNEL	FREQUENCY	CHANNEL	FREQUENCY
36	5180 MHz	44	5220 MHz
40	5200 MHz	48	5240 MHz

2 channels are provided for 802.11n (40MHz):

CHANNEL	FREQUENCY	CHANNEL	FREQUENCY
38	5190 MHz	46	5230 MHz

FOR 5260 ~ 5320MHz

4 channels are provided for 802.11a, 802.11n (20MHz):

CHANNEL	FREQUENCY	CHANNEL	FREQUENCY
52	5260 MHz	60	5300 MHz
56	5280 MHz	64	5320 MHz

2 channels are provided for 802.11n (40MHz):

CHANNEL	FREQUENCY	CHANNEL	FREQUENCY
54	5270 MHz	62	5310 MHz



A D T

WLAN 5500 ~ 5700MHz

11 channels are provided for 802.11a, 802.11n (20MHz):

CHANNEL	FREQUENCY	CHANNEL	FREQUENCY
100	5500MHz	124	5620MHz
104	5520MHz	128	5640MHz
108	5540MHz	132	5660MHz
112	5560MHz	136	5680MHz
116	5580MHz	140	5700MHz
120	5600MHz		

5 channels are provided for 802.11n (40MHz):

CHANNEL	FREQUENCY	CHANNEL	FREQUENCY
102	5510MHz	126	5630MHz
110	5550MHz	134	5670MHz
118	5590MHz		

FOR 5.0GHz (5745 ~ 5825MHz):

5 channels are provided for 802.11a, 802.11n (20MHz):

CHANNEL	FREQUENCY	CHANNEL	FREQUENCY
149	5745MHz	161	5805MHz
153	5765MHz	165	5825MHz
157	5785MHz		

2 channels are provided for 802.11n (40MHz):

CHANNEL	FREQUENCY	CHANNEL	FREQUENCY
151	5755MHz	159	5795MHz



A D T

3.2.1 TEST MODE APPLICABILITY AND TESTED CHANNEL DETAIL

EUT CONFIGURE MODE	APPLICABLE TO				DESCRIPTION
	RE \geq 1G	RE $<$ 1G	PLC	APCM	
-	√	√	√	√	-

Where **RE \geq 1G**: Radiated Emission above 1GHz **RE $<$ 1G**: Radiated Emission below 1GHz
PLC: Power Line Conducted Emission **APCM**: Antenna Port Conducted Measurement

NOTE: The EUT had been pre-tested on the positioned of each 3 axis. The worst case was found when positioned on **Z-plane** for 5180-5240MHz & 5260-5320MHz & 5500-5700MHz and **X-plane** for 5745-5825MHz.

RADIATED EMISSION TEST (ABOVE 1GHz):

Pre-Scan has been conducted to determine the worst-case mode from all possible combinations between available modulations, data rates and antenna ports (if EUT with antenna diversity architecture).

Following channel(s) was (were) selected for the final test as listed below.

EUT CONFIGURE MODE	MODE	FREQ. BAND (MHz)	AVAILABLE CHANNEL	TESTED CHANNEL	MODULATION TECHNOLOGY	MODULATION TYPE	DATA RATE (Mbps)
-	802.11a	5180-5240	36 to 48	36, 44, 48	OFDM	BPSK	6.0
	802.11n (20MHz)		36 to 48	36, 44, 48	OFDM	BPSK	MCS0
	802.11n (40MHz)		38 to 46	38, 46	OFDM	BPSK	MCS0
-	802.11a	5260-5320	52 to 64	52, 60, 64	OFDM	BPSK	6.0
	802.11n (20MHz)		52 to 64	52, 60, 64	OFDM	BPSK	MCS0
	802.11n (40MHz)		54 to 62	54, 62	OFDM	BPSK	MCS0
-	802.11a	5500-5700	100 to 140	100, 116, 140	OFDM	BPSK	6.0
	802.11n (20MHz)		100 to 140	100, 116, 140	OFDM	BPSK	MCS0
	802.11n (40MHz)		102 to 134	102, 110, 134	OFDM	BPSK	MCS0
-	802.11a	5745-5825	149 to 165	149, 157, 165	OFDM	BPSK	6.0
	802.11n (20MHz)		149 to 165	149, 157, 165	OFDM	BPSK	MCS0
	802.11n (40MHz)		151 to 159	151, 159	OFDM	BPSK	MCS0

RADIATED EMISSION TEST (BELOW 1GHz):

Pre-Scan has been conducted to determine the worst-case mode from all possible combinations between available modulations, data rates and antenna ports (if EUT with antenna diversity architecture).

Following channel(s) was (were) selected for the final test as listed below.

EUT CONFIGURE MODE	MODE	FREQ. BAND (MHz)	AVAILABLE CHANNEL	TESTED CHANNEL	MODULATION TECHNOLOGY	MODULATION TYPE	DATA RATE (Mbps)
-	802.11n (40MHz)	5180-5240	38 to 46	38	OFDM	BPSK	MCS0
-	802.11n (40MHz)	5260-5320	54 to 62	62	OFDM	BPSK	MCS0
-	802.11n (20MHz)	5500-5700	100 to 140	140	OFDM	BPSK	MCS0
-	802.11n (20MHz)	5745-5825	149 to 165	165	OFDM	BPSK	MCS0



POWER LINE CONDUCTED EMISSION TEST:

EUT CONFIGURE MODE	MODE	FREQ. BAND (MHz)	AVAILABLE CHANNEL	TESTED CHANNEL	MODULATION TECHNOLOGY	MODULATION TYPE	DATA RATE (Mbps)
-	802.11n (40MHz)	5180-5240	38 to 46	38	OFDM	BPSK	MCS0

BANDEDGE MEASUREMENT:

Pre-Scan has been conducted to determine the worst-case mode from all possible combinations between available modulations, data rates and antenna ports (if EUT with antenna diversity architecture).

Following channel(s) was (were) selected for the final test as listed below.

EUT CONFIGURE MODE	MODE	FREQ. BAND (MHz)	AVAILABLE CHANNEL	TESTED CHANNEL	MODULATION TECHNOLOGY	MODULATION TYPE	DATA RATE (Mbps)
-	802.11a	5180-5240	36 to 48	36, 44, 48	OFDM	BPSK	6.0
	802.11n (20MHz)		36 to 48	36, 44, 48	OFDM	BPSK	MCS0
	802.11n (40MHz)		38 to 46	38, 46	OFDM	BPSK	MCS0
-	802.11a	5260-5320	52 to 64	52, 60, 64	OFDM	BPSK	6.0
	802.11n (20MHz)		52 to 64	52, 60, 64	OFDM	BPSK	MCS0
	802.11n (40MHz)		54 to 62	54, 62	OFDM	BPSK	MCS0
-	802.11a	5500-5700	100 to 140	100, 116, 140	OFDM	BPSK	6.0
	802.11n (20MHz)		100 to 140	100, 116, 140	OFDM	BPSK	MCS0
	802.11n (40MHz)		102 to 134	102, 110, 134	OFDM	BPSK	MCS0
-	802.11a	5745-5825	149 to 165	149, 157, 165	OFDM	BPSK	6.0
	802.11n (20MHz)		149 to 165	149, 157, 165	OFDM	BPSK	MCS0
	802.11n (40MHz)		151 to 159	151, 159	OFDM	BPSK	MCS0



ANTENNA PORT CONDUCTED MEASUREMENT:

- This item includes all test value of each mode, but only includes spectrum plot of worst value of each mode.
- Pre-Scan has been conducted to determine the worst-case mode from all possible combinations between available modulations, data rates and antenna ports (if EUT with antenna diversity architecture).
- Following channel(s) was (were) selected for the final test as listed below.

EUT CONFIGURE MODE	MODE	FREQ. BAND (MHz)	AVAILABLE CHANNEL	TESTED CHANNEL	MODULATION TECHNOLOGY	MODULATION TYPE	DATA RATE (Mbps)
-	802.11a	5180-5240	36 to 48	36, 44, 48	OFDM	BPSK	6.0
	802.11n (20MHz)		36 to 48	36, 44, 48	OFDM	BPSK	MCS0
	802.11n (40MHz)		38 to 46	38, 46	OFDM	BPSK	MCS0
-	802.11a	5260-5320	52 to 64	52, 60, 64	OFDM	BPSK	6.0
	802.11n (20MHz)		52 to 64	52, 60, 64	OFDM	BPSK	MCS0
	802.11n (40MHz)		54 to 62	54, 62	OFDM	BPSK	MCS0
-	802.11a	5500-5700	100 to 140	100, 116, 140	OFDM	BPSK	6.0
	802.11n (20MHz)		100 to 140	100, 116, 140	OFDM	BPSK	MCS0
	802.11n (40MHz)		102 to 134	102, 110, 134	OFDM	BPSK	MCS0
-	802.11a	5745-5825	149 to 165	149, 157, 165	OFDM	BPSK	6.0
	802.11n (20MHz)		149 to 165	149, 157, 165	OFDM	BPSK	MCS0
	802.11n (40MHz)		151 to 159	151, 159	OFDM	BPSK	MCS0

TEST CONDITION:

APPLICABLE TO	ENVIRONMENTAL CONDITIONS	INPUT POWER	TESTED BY
RE≥1G	25deg. C, 65%RH	120Vac, 60Hz	Karl Lee
RE<1G	25deg. C, 65%RH	120Vac, 60Hz	Kay Wu
PLC	25deg. C, 65%RH	120Vac, 60Hz	Toby Tian
APCM	25deg. C, 65%RH	3.7Vdc	Carlos Chen

3.3 DESCRIPTION OF SUPPORT UNITS

The EUT has been tested as an independent unit together with other necessary accessories or support units.

3.3.1 CONFIGURATION OF SYSTEM UNDER TEST

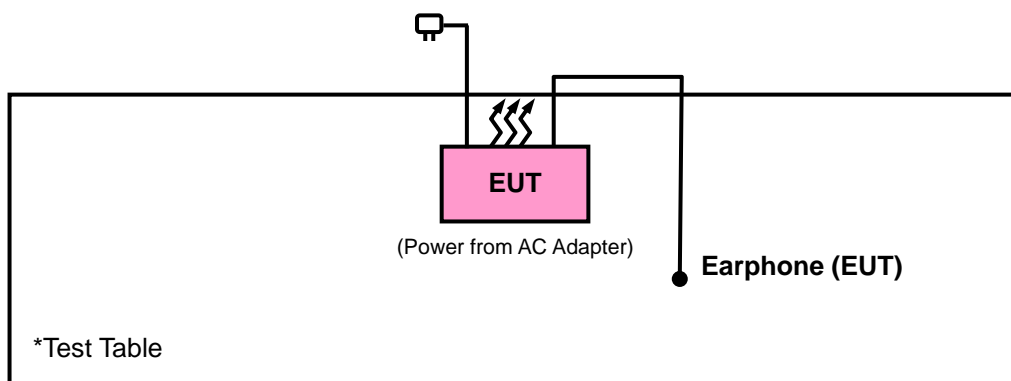

3.4 DUTY CYCLE TEST SIGNAL

MODULATION TYPE: BPSK

802.11a: Duty cycle = $2.011/2.548 = 0.789$, Duty factor = $10 * \log(1/0.789) = 1.03$

802.11n (20MHz): Duty cycle = $1.891/2.396 = 0.789$, Duty factor = $10 * \log(1/0.789) = 1.03$

802.11n (40MHz): Duty cycle = $0.897/1.434 = 0.626$, Duty factor = $10 * \log(1/0.626) = 2.04$

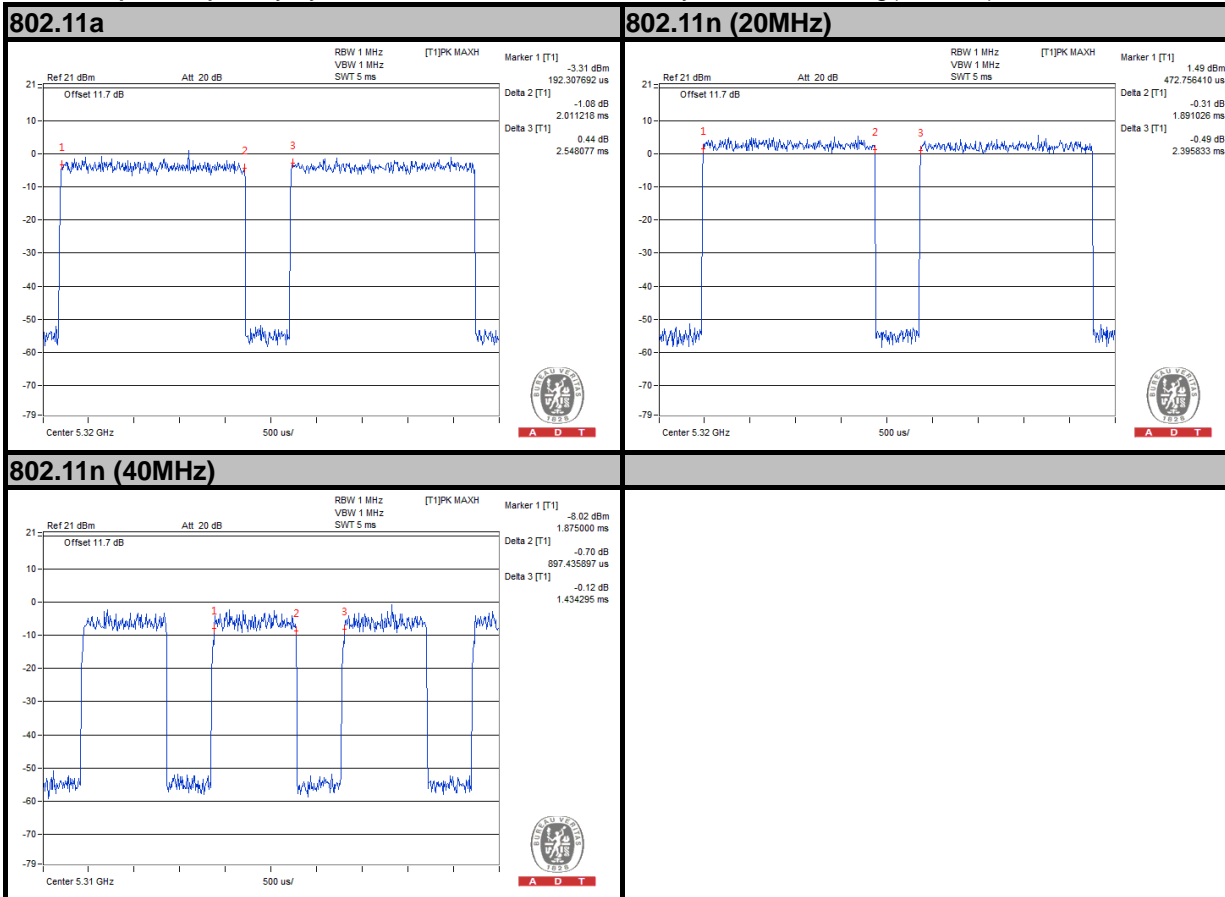



A D T

MODULATION TYPE: QPSK

802.11a: Duty cycle = $1.026/1.530 = 0.671$, Duty factor = $10 * \log(1/0.671) = 1.74$

802.11n (20MHz): Duty cycle = $0.954/1.458 = 0.654$, Duty factor = $10 * \log(1/0.654) = 1.85$

802.11n (40MHz): Duty cycle = $448.72/985.58 = 0.455$, Duty factor = $10 * \log(1/0.455) = 3.42$

802.11a

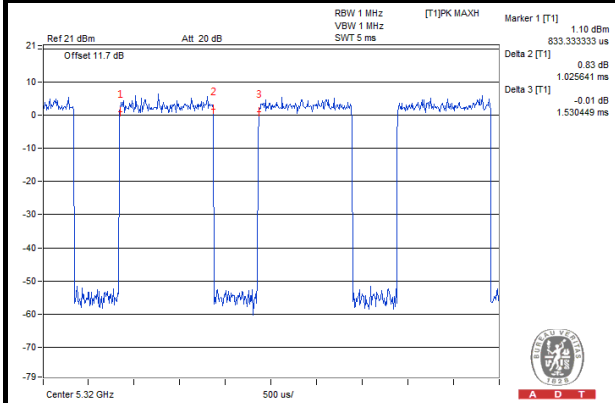

802.11n (20MHz)

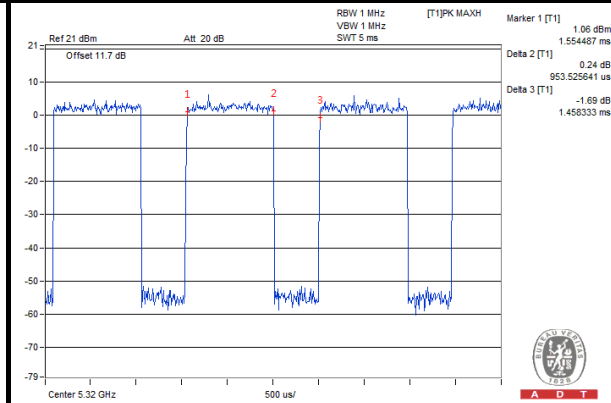

802.11n (40MHz)

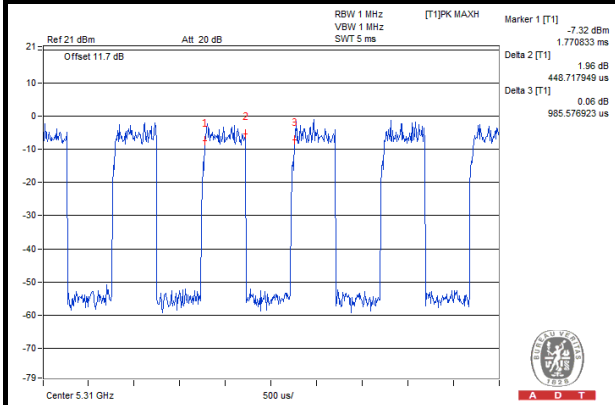



A D T

MODULATION TYPE: 16QAM

802.11a: Duty cycle = $0.513/1.026 = 0.5$, Duty factor = $10 * \log(1/0.5) = 3.01$

802.11n (20MHz): Duty cycle = $488.78/993.59 = 0.492$, Duty factor = $10 * \log(1/0.492) = 3.08$

802.11n (40MHz): Duty cycle = $224.36/761.22 = 0.295$, Duty factor = $10 * \log(1/0.295) = 5.31$

802.11a

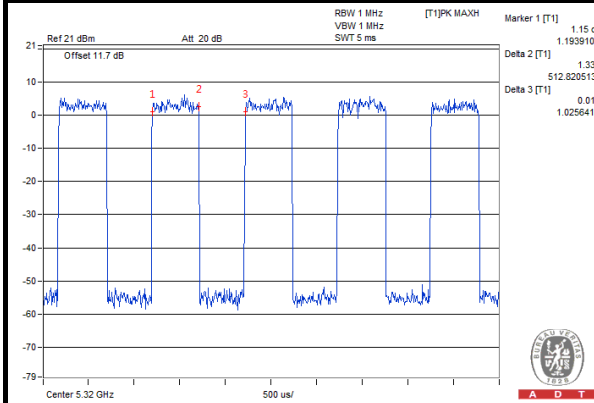

802.11n (20MHz)

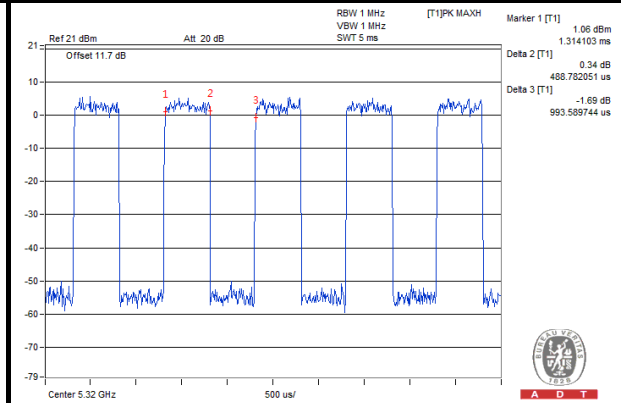

802.11n (40MHz)

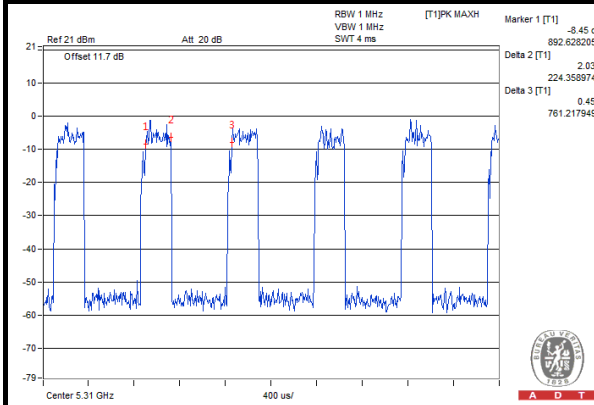



A D T

MODULATION TYPE: 64QAM

802.11a: Duty cycle = $264.42/772.23 = 0.342$, Duty factor = $10 * \log(1/0.342) = 4.65$

802.11n (20MHz): Duty cycle = $264.42/769.23 = 0.344$, Duty factor = $10 * \log(1/0.344) = 4.64$

802.11n (40MHz): Duty cycle = $118.59/652.24 = 0.182$, Duty factor = $10 * \log(1/0.182) = 7.40$

802.11a

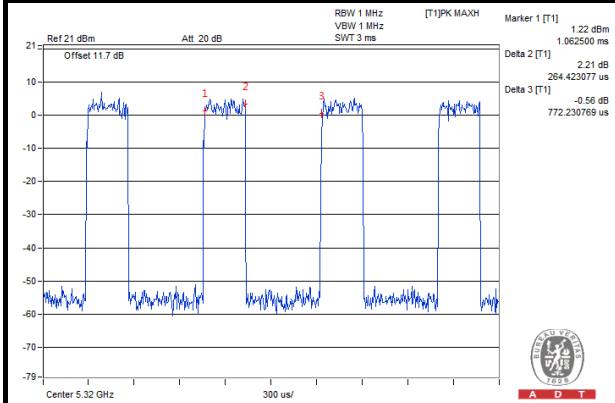

802.11n (20MHz)

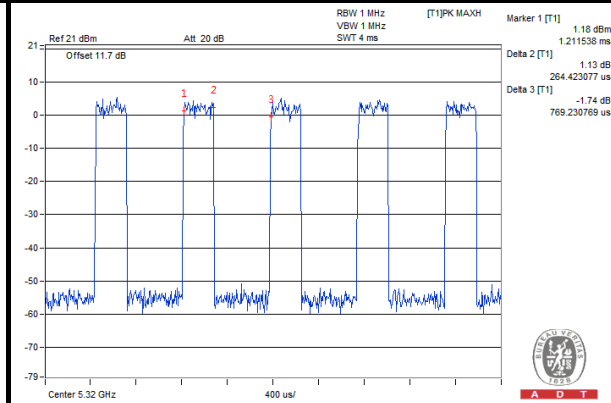

802.11n (40MHz)

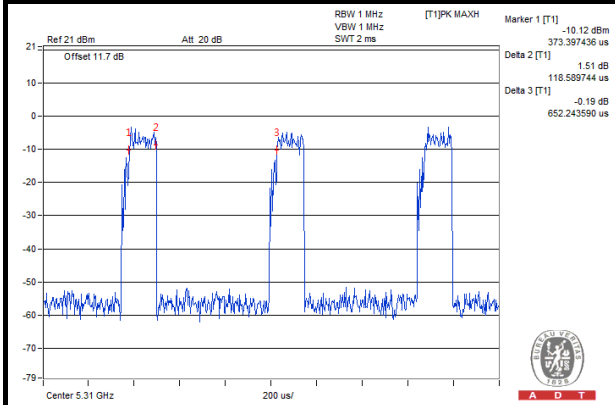

3.5 GENERAL DESCRIPTION OF APPLIED STANDARDS

The EUT is a RF Product. According to the specifications of the manufacturer, it must comply with the requirements of the following standards:

FCC Part 15, Subpart E (15.407)

789033 D02 General UNII Test Procedures New Rules v01

ANSI C63.10-2013

All test items have been performed and recorded as per the above standards.

NOTE: The EUT has been verified to comply with the requirements of FCC Part 15, Subpart B, Class B (DoC). The test report has been issued separately.

4. TEST TYPES AND RESULTS

4.1 RADIATED EMISSION AND BANDEDGE MEASUREMENT

4.1.1 LIMITS OF RADIATED EMISSION AND BANDEDGE MEASUREMENT

Radiated emissions which fall in the restricted bands must comply with the radiated emission limits specified as below table:

FREQUENCIES (MHz)	FIELD STRENGTH (microvolts/meter)	MEASUREMENT DISTANCE (meters)
0.009 ~ 0.490	2400/F(kHz)	300
0.490 ~ 1.705	24000/F(kHz)	30
1.705 ~ 30.0	30	30
30 ~ 88	100	3
88 ~ 216	150	3
216 ~ 960	200	3
Above 960	500	3

NOTE:

1. The lower limit shall apply at the transition frequencies.
2. Emission level (dBuV/m) = 20 log Emission level (uV/m).
3. For frequencies above 1000MHz, the field strength limits are based on average detector, however, the peak field strength of any emission shall not exceed the maximum permitted average limits, specified above by more than 20dB under any condition of modulation.

4.1.2 LIMITS OF UNWANTED EMISSION OUT OF THE RESTRICTED BANDS

APPLICABLE TO	LIMIT	
789033 D02 General UNII Test Procedures New Rules v01	FIELD STRENGTH AT 3m	
	PK: 74 (dBµV/m)	AV: 54 (dBµV/m)
APPLICABLE TO	EIRP LIMIT	EQUIVALENT FIELD STRENGTH AT 3m
15.407(b)(1)	PK: -27 (dBm/MHz)	PK: 68.2 (dBµV/m)
15.407(b)(2)		
15.407(b)(3)		
15.407(b)(4)	PK: -27 (dBm/MHz) ^{*1} PK: -17 (dBm/MHz) ^{*2}	PK: 68.2 (dBµV/m) ^{*1} PK: 78.2 (dBµV/m) ^{*2}

NOTE: ^{*1} beyond 10MHz of the band edge ^{*2} within 10 MHz of band edge

The following formula is used to convert the equipment isotropic radiated power (eirp) to field strength:

$$E = \frac{1000000\sqrt{30P}}{3} \mu\text{V/m, where P is the eirp (Watts).}$$



4.1.3 TEST INSTRUMENTS

DESCRIPTION & MANUFACTURER	MODEL NO.	SERIAL NO.	DATE OF CALIBRATION	DUE DATE OF CALIBRATION
Spectrum Analyzer Agilent Technologies	N9038A	MY52260177	May 19, 2015	May 18, 2016
Spectrum Analyzer ROHDE & SCHWARZ	FSU43	101261	Dec. 10, 2014	Dec. 09, 2015
BILOG Antenna SCHWARZBECK	VULB9168	9168-472	Feb. 04, 2015	Feb. 04, 2016
HORN Antenna ETS-Lindgren	3117	00143293	Aug. 28, 2014	Aug. 27, 2015
Bluetooth Tester	CBT	100980	Apr. 27, 2015	Apr. 26, 2016
Agilent Communications Tester-Wireless	8960 Series 10	MY53201073	Jul. 06, 2015	Jul. 05, 2017
Preamplifier Agilent	310N	187226	Jun. 29, 2015	Jun. 28, 2016
Preamplifier Agilent	83017A	980116	Jan. 09, 2015	Jan. 08, 2016
Power Meter Anritsu	ML2495A	1232002	Sep. 17, 2014	Sep. 16, 2015
Power Sensor Anritsu	MA2411B	1207325	Sep. 17, 2014	Sep. 16, 2015
RF signal cable ETS-LINDGREN	5D-FB	Cable-CH1-01(RFC-SMS-100-SMS-120+RFC-SMS-100-SMS-400)	Jun. 27, 2015	Jun. 26, 2016
RF signal cable ETS-LINDGREN	8D-FB	Cable-CH1-02(RFC-SMS-100-SMS-24)	Jun. 27, 2015	Jun. 26, 2016
Software BV ADT	E3 8.130425b	NA	NA	NA
Antenna Tower MF	NA	NA	NA	NA
Turn Table MF	NA	NA	NA	NA
Antenna Tower & Turn Table Controller MF	MF-7802	NA	NA	NA

- NOTE:**
1. The calibration interval of the above test instruments is 12 months and the calibrations are traceable to NML/ROC and NIST/USA.
 2. The test was performed in HsinTien Chamber 1.
 3. The horn antenna and HP preamplifier (model: 8449B) are used only for the measurement of emission frequency above 1GHz if tested.
 4. The FCC Site Registration No. is 149147.
 5. The IC Site Registration No. is IC 7450I-1.

4.1.4 TEST PROCEDURES

- a. The EUT was placed on the top of a rotating table 0.8 meters (for below 1GHz) / 1.5 meters (for above 1GHz) above the ground at 3 meter chamber room for test. The table was rotated 360 degrees to determine the position of the highest radiation.
- b. The EUT was set 3 meters away from the interference-receiving antenna, which was mounted on the top of a variable-height antenna tower.
- c. The antenna is a broadband antenna, and its height is varied from one meter to four meters above the ground to determine the maximum value of the field strength. Both horizontal and vertical polarizations of the antenna are set to make the measurement.
- d. For each suspected emission, the EUT was arranged to its worst case and then the antenna was tuned to heights from 1 meter to 4 meters and the rotatable table was turned from 0 degrees to 360 degrees to find the maximum reading.
- e. The test-receiver system was set to Peak Detect Function and Specified Bandwidth with Maximum Hold Mode.
- f. If the emission level of the EUT in peak mode was 10dB lower than the limit specified, then testing could be stopped and the peak values of the EUT would be reported. Otherwise the emissions that did not have 10dB margin would be re-tested one by one using peak, quasi-peak or average method as specified and then reported in a data sheet.

NOTE:

1. The resolution bandwidth and video bandwidth of test receiver/spectrum analyzer is 120kHz for Peak detection (PK) and Quasi-peak detection (QP) at frequency below 1GHz.
2. The resolution bandwidth of test receiver/spectrum analyzer is 1MHz and video bandwidth is 3MHz for Peak detection at frequency above 1GHz.
3. The resolution bandwidth of test receiver/spectrum analyzer is 1MHz and the video bandwidth is 1kHz (Duty cycle < 98%) or 10Hz (Duty cycle > 98%) for Average detection (AV) at frequency above 1GHz.
4. All modes of operation were investigated and the worst-case emissions are reported.

4.1.5 DEVIATION FROM TEST STANDARD

No deviation.

4.1.6 TEST SETUP

<Frequency Range 30MHz ~ 1GHz>

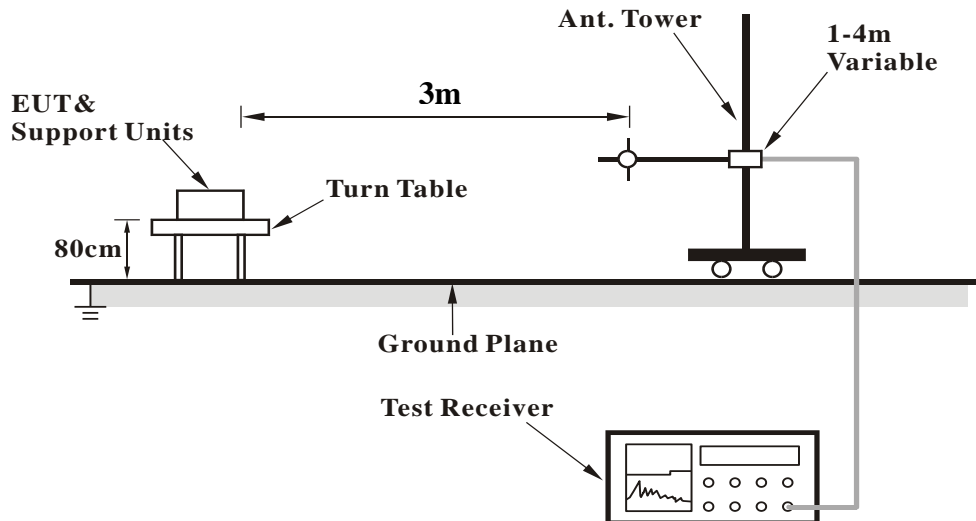

<Frequency Range above 1GHz>

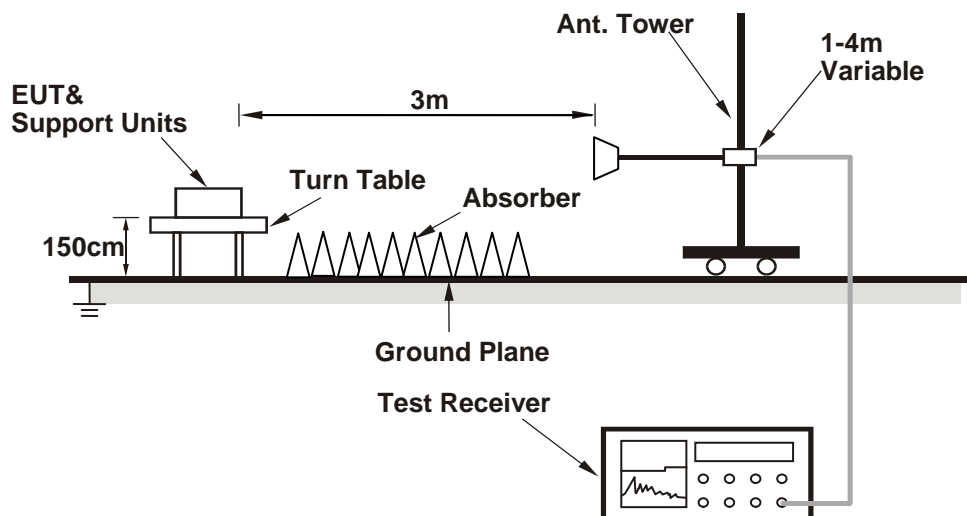

For the actual test configuration, please refer to the attached file (Test Setup Photo).

4.1.7 EUT OPERATING CONDITIONS

- Placed the EUT on a testing table.
- Use the software to control the EUT under transmission condition continuously at specific channel frequency.



A D T

4.1.8 TEST RESULTS

ABOVE 1GHz WORST-CASE DATA

802.11a

EUT TEST CONDITION		MEASUREMENT DETAIL	
CHANNEL	Channel 36	FREQUENCY RANGE	1GHz ~ 40GHz
INPUT POWER	120Vac, 60 Hz	DETECTOR FUNCTION	Peak (PK) Average (AV)
ENVIRONMENTAL CONDITIONS	25deg. C, 65%RH	TESTED BY	Karl Lee

ANTENNA POLARITY & TEST DISTANCE: HORIZONTAL AT 3 M

FREQ. (MHz)	EMISSION LEVEL (dBuV/m)	READ LEVEL (dBuV)	LIMIT (dBuV/m)	MARGIN (dB)	ANTENNA FACTOR (dB/m)	CABLE LOSS (dB)	PREAMP FACTOR (dB)	ANTENNA HEIGHT (cm)	TABLE ANGLE (Degree)	REMARK
5114	42.79	34.59	54	-11.21	34.09	8.1	33.99	200	142	Average
5114	57.09	48.89	74	-16.91	34.09	8.1	33.99	200	142	Peak
5180	89.31	81			34.15	8.16	34	200	142	Average
5180	97.15	88.84			34.15	8.16	34	200	142	Peak
5352	42.66	34.03	54	-11.34	34.28	8.38	34.03	200	142	Average
5352	56.89	48.26	74	-17.11	34.28	8.38	34.03	200	142	Peak

ANTENNA POLARITY & TEST DISTANCE: VERTICAL AT 3 M

FREQ. (MHz)	EMISSION LEVEL (dBuV/m)	READ LEVEL (dBuV)	LIMIT (dBuV/m)	MARGIN (dB)	ANTENNA FACTOR (dB/m)	CABLE LOSS (dB)	PREAMP FACTOR (dB)	ANTENNA HEIGHT (cm)	TABLE ANGLE (Degree)	REMARK
5150	44.15	35.9	54	-9.85	34.12	8.13	34	101	211	Average
5150	56.98	48.73	74	-17.02	34.12	8.13	34	101	211	Peak
5180	97.31	89			34.15	8.16	34	101	211	Average
5180	105.48	97.17			34.15	8.16	34	101	211	Peak
5440	42.82	34.03	54	-11.18	34.35	8.48	34.04	101	211	Average
5440	57.12	48.33	74	-16.88	34.35	8.48	34.04	101	211	Peak

REMARKS:

- Emission Level = Read Level + Antenna Factor + Cable Loss - Preamp Factor
Margin value = Emission level – Limit value
- 5180MHz: Fundamental frequency.



A D T

EUT TEST CONDITION		MEASUREMENT DETAIL	
CHANNEL	Channel 44	FREQUENCY RANGE	1GHz ~ 40GHz
INPUT POWER	120Vac, 60 Hz	DETECTOR FUNCTION	Peak (PK) Average (AV)
ENVIRONMENTAL CONDITIONS	25deg. C, 65%RH	TESTED BY	Karl Lee

ANTENNA POLARITY & TEST DISTANCE: HORIZONTAL AT 3 M										
FREQ. (MHz)	EMISSION LEVEL (dBuV/m)	READ LEVEL (dBuV)	LIMIT (dBuV/m)	MARGIN (dB)	ANTENNA FACTOR (dB/m)	CABLE LOSS (dB)	PREAMP FACTOR (dB)	ANTENNA HEIGHT (cm)	TABLE ANGLE (Degree)	REMARK
5068	42.49	34.39	54	-11.51	34.05	8.03	33.98	211	142	Average
5068	57.81	49.71	74	-16.19	34.05	8.03	33.98	211	142	Peak
5220	91.9	83.51			34.17	8.22	34	211	142	Average
5220	99.59	91.2			34.17	8.22	34	211	142	Peak
5428	42.91	34.14	54	-11.09	34.33	8.48	34.04	211	142	Average
5428	57.86	49.09	74	-16.14	34.33	8.48	34.04	211	142	Peak

ANTENNA POLARITY & TEST DISTANCE: VERTICAL AT 3 M										
FREQ. (MHz)	EMISSION LEVEL (dBuV/m)	READ LEVEL (dBuV)	LIMIT (dBuV/m)	MARGIN (dB)	ANTENNA FACTOR (dB/m)	CABLE LOSS (dB)	PREAMP FACTOR (dB)	ANTENNA HEIGHT (cm)	TABLE ANGLE (Degree)	REMARK
5116	42.59	34.39	54	-11.41	34.09	8.1	33.99	100	211	Average
5116	56.93	48.73	74	-17.07	34.09	8.1	33.99	100	211	Peak
5220	99.2	90.81			34.17	8.22	34	100	211	Average
5220	107.55	99.16			34.17	8.22	34	100	211	Peak
5398	43.01	34.29	54	-10.99	34.32	8.44	34.04	100	211	Average
5398	57.77	49.05	74	-16.23	34.32	8.44	34.04	100	211	Peak

REMARKS:

- Emission Level = Read Level + Antenna Factor + Cable Loss - Preamp Factor
Margin value = Emission level – Limit value
- 5220MHz: Fundamental frequency.



A D T

EUT TEST CONDITION		MEASUREMENT DETAIL	
CHANNEL	Channel 48	FREQUENCY RANGE	1GHz ~ 40GHz
INPUT POWER	120Vac, 60 Hz	DETECTOR FUNCTION	Peak (PK) Average (AV)
ENVIRONMENTAL CONDITIONS	25deg. C, 65%RH	TESTED BY	Karl Lee

ANTENNA POLARITY & TEST DISTANCE: HORIZONTAL AT 3 M										
FREQ. (MHz)	EMISSION LEVEL (dBuV/m)	READ LEVEL (dBuV)	LIMIT (dBuV/m)	MARGIN (dB)	ANTENNA FACTOR (dB/m)	CABLE LOSS (dB)	PREAMP FACTOR (dB)	ANTENNA HEIGHT (cm)	TABLE ANGLE (Degree)	REMARK
5140	42.75	34.49	54	-11.25	34.12	8.13	33.99	208	142	Average
5140	56.81	48.55	74	-17.19	34.12	8.13	33.99	208	142	Peak
5240	91.44	83			34.19	8.26	34.01	208	142	Average
5240	99.84	91.4			34.19	8.26	34.01	208	142	Peak
5352	42.56	33.93	54	-11.44	34.28	8.38	34.03	208	142	Average
5352	58.65	50.02	74	-15.35	34.28	8.38	34.03	208	142	Peak

ANTENNA POLARITY & TEST DISTANCE: VERTICAL AT 3 M										
FREQ. (MHz)	EMISSION LEVEL (dBuV/m)	READ LEVEL (dBuV)	LIMIT (dBuV/m)	MARGIN (dB)	ANTENNA FACTOR (dB/m)	CABLE LOSS (dB)	PREAMP FACTOR (dB)	ANTENNA HEIGHT (cm)	TABLE ANGLE (Degree)	REMARK
5142	42.85	34.59	54	-11.15	34.12	8.13	33.99	100	211	Average
5142	57.28	49.02	74	-16.72	34.12	8.13	33.99	100	211	Peak
5240	99.44	91			34.19	8.26	34.01	100	211	Average
5240	107.59	99.15			34.19	8.26	34.01	100	211	Peak
5404	42.96	34.24	54	-11.04	34.32	8.44	34.04	100	211	Average
5404	57.1	48.38	74	-16.9	34.32	8.44	34.04	100	211	Peak

REMARKS:

- Emission Level = Read Level + Antenna Factor + Cable Loss - Preamp Factor
Margin value = Emission level – Limit value
- 5240MHz: Fundamental frequency.



A D T

EUT TEST CONDITION		MEASUREMENT DETAIL	
CHANNEL	Channel 52	FREQUENCY RANGE	1GHz ~ 40GHz
INPUT POWER	120Vac, 60 Hz	DETECTOR FUNCTION	Peak (PK) Average (AV)
ENVIRONMENTAL CONDITIONS	25deg. C, 65%RH	TESTED BY	Karl Lee

ANTENNA POLARITY & TEST DISTANCE: HORIZONTAL AT 3 M										
FREQ. (MHz)	EMISSION LEVEL (dBuV/m)	READ LEVEL (dBuV)	LIMIT (dBuV/m)	MARGIN (dB)	ANTENNA FACTOR (dB/m)	CABLE LOSS (dB)	PREAMP FACTOR (dB)	ANTENNA HEIGHT (cm)	TABLE ANGLE (Degree)	REMARK
5078	42.5	34.38	54	-11.5	34.07	8.03	33.98	199	135	Average
5078	57.61	49.49	74	-16.39	34.07	8.03	33.98	199	135	Peak
5260	91.67	83.21			34.21	8.26	34.01	199	135	Average
5260	99.4	90.94			34.21	8.26	34.01	199	135	Peak
5412	42.78	34.05	54	-11.22	34.33	8.44	34.04	199	135	Average
5412	56.44	47.71	74	-17.56	34.33	8.44	34.04	199	135	Peak

ANTENNA POLARITY & TEST DISTANCE: VERTICAL AT 3 M										
FREQ. (MHz)	EMISSION LEVEL (dBuV/m)	READ LEVEL (dBuV)	LIMIT (dBuV/m)	MARGIN (dB)	ANTENNA FACTOR (dB/m)	CABLE LOSS (dB)	PREAMP FACTOR (dB)	ANTENNA HEIGHT (cm)	TABLE ANGLE (Degree)	REMARK
5024	42.5	34.47	54	-11.5	34.03	7.97	33.97	114	204	Average
5024	56.65	48.62	74	-17.35	34.03	7.97	33.97	114	204	Peak
5260	99.87	91.41			34.21	8.26	34.01	114	204	Average
5260	107.04	98.58			34.21	8.26	34.01	114	204	Peak
5448	42.97	34.14	54	-11.03	34.36	8.51	34.04	114	204	Average
5448	57.39	48.56	74	-16.61	34.36	8.51	34.04	114	204	Peak

REMARKS:

- Emission Level = Read Level + Antenna Factor + Cable Loss - Preamp Factor
Margin value = Emission level – Limit value
- 5260MHz: Fundamental frequency.



A D T

EUT TEST CONDITION		MEASUREMENT DETAIL	
CHANNEL	Channel 60	FREQUENCY RANGE	1GHz ~ 40GHz
INPUT POWER	120Vac, 60 Hz	DETECTOR FUNCTION	Peak (PK) Average (AV)
ENVIRONMENTAL CONDITIONS	25deg. C, 65%RH	TESTED BY	Karl Lee

ANTENNA POLARITY & TEST DISTANCE: HORIZONTAL AT 3 M										
FREQ. (MHz)	EMISSION LEVEL (dBuV/m)	READ LEVEL (dBuV)	LIMIT (dBuV/m)	MARGIN (dB)	ANTENNA FACTOR (dB/m)	CABLE LOSS (dB)	PREAMP FACTOR (dB)	ANTENNA HEIGHT (cm)	TABLE ANGLE (Degree)	REMARK
5070	42.59	34.49	54	-11.41	34.05	8.03	33.98	217	135	Average
5070	57.55	49.45	74	-16.45	34.05	8.03	33.98	217	135	Peak
5300	91.26	82.72			34.24	8.32	34.02	217	135	Average
5300	99.08	90.54			34.24	8.32	34.02	217	135	Peak
5446	43.57	34.74	54	-10.43	34.36	8.51	34.04	217	135	Average
5446	57.35	48.52	74	-16.65	34.36	8.51	34.04	217	135	Peak

ANTENNA POLARITY & TEST DISTANCE: VERTICAL AT 3 M										
FREQ. (MHz)	EMISSION LEVEL (dBuV/m)	READ LEVEL (dBuV)	LIMIT (dBuV/m)	MARGIN (dB)	ANTENNA FACTOR (dB/m)	CABLE LOSS (dB)	PREAMP FACTOR (dB)	ANTENNA HEIGHT (cm)	TABLE ANGLE (Degree)	REMARK
5070	42.49	34.39	54	-11.51	34.05	8.03	33.98	128	204	Average
5070	56.64	48.54	74	-17.36	34.05	8.03	33.98	128	204	Peak
5300	99.26	90.72			34.24	8.32	34.02	128	204	Average
5300	107.41	98.87			34.24	8.32	34.02	128	204	Peak
5460	44.87	36.05	54	-9.13	34.36	8.51	34.05	128	204	Average
5460	56.63	47.81	74	-17.37	34.36	8.51	34.05	128	204	Peak

REMARKS:

- Emission Level = Read Level + Antenna Factor + Cable Loss - Preamp Factor
Margin value = Emission level – Limit value
- 5300MHz: Fundamental frequency.



A D T

EUT TEST CONDITION		MEASUREMENT DETAIL	
CHANNEL	Channel 64	FREQUENCY RANGE	1GHz ~ 40GHz
INPUT POWER	120Vac, 60 Hz	DETECTOR FUNCTION	Peak (PK) Average (AV)
ENVIRONMENTAL CONDITIONS	25deg. C, 65%RH	TESTED BY	Karl Lee

ANTENNA POLARITY & TEST DISTANCE: HORIZONTAL AT 3 M										
FREQ. (MHz)	EMISSION LEVEL (dBuV/m)	READ LEVEL (dBuV)	LIMIT (dBuV/m)	MARGIN (dB)	ANTENNA FACTOR (dB/m)	CABLE LOSS (dB)	PREAMP FACTOR (dB)	ANTENNA HEIGHT (cm)	TABLE ANGLE (Degree)	REMARK
5058	42.39	34.29	54	-11.61	34.05	8.03	33.98	215	141	Average
5058	57.92	49.82	74	-16.08	34.05	8.03	33.98	215	141	Peak
5320	91.3	82.72			34.25	8.35	34.02	215	141	Average
5320	99.75	91.17			34.25	8.35	34.02	215	141	Peak
5432	43.02	34.23	54	-10.98	34.35	8.48	34.04	215	141	Average
5432	58.03	49.24	74	-15.97	34.35	8.48	34.04	215	141	Peak

ANTENNA POLARITY & TEST DISTANCE: VERTICAL AT 3 M										
FREQ. (MHz)	EMISSION LEVEL (dBuV/m)	READ LEVEL (dBuV)	LIMIT (dBuV/m)	MARGIN (dB)	ANTENNA FACTOR (dB/m)	CABLE LOSS (dB)	PREAMP FACTOR (dB)	ANTENNA HEIGHT (cm)	TABLE ANGLE (Degree)	REMARK
5124	42.5	34.28	54	-11.5	34.11	8.1	33.99	134	206	Average
5124	56.67	48.45	74	-17.33	34.11	8.1	33.99	134	206	Peak
5320	99.4	90.82			34.25	8.35	34.02	134	206	Average
5320	107.88	99.3			34.25	8.35	34.02	134	206	Peak
5374	44.71	36.05	54	-9.29	34.29	8.41	34.04	134	206	Average
5374	57.37	48.71	74	-16.63	34.29	8.41	34.04	134	206	Peak

REMARKS:

- Emission Level = Read Level + Antenna Factor + Cable Loss - Preamp Factor
Margin value = Emission level – Limit value
- 5320MHz: Fundamental frequency.



A D T

EUT TEST CONDITION		MEASUREMENT DETAIL	
CHANNEL	Channel 100	FREQUENCY RANGE	1GHz ~ 40GHz
INPUT POWER	120Vac, 60 Hz	DETECTOR FUNCTION	Peak (PK) Average (AV)
ENVIRONMENTAL CONDITIONS	25deg. C, 65%RH	TESTED BY	Karl Lee

ANTENNA POLARITY & TEST DISTANCE: HORIZONTAL AT 3 M										
FREQ. (MHz)	EMISSION LEVEL (dBuV/m)	READ LEVEL (dBuV)	LIMIT (dBuV/m)	MARGIN (dB)	ANTENNA FACTOR (dB/m)	CABLE LOSS (dB)	PREAMP FACTOR (dB)	ANTENNA HEIGHT (cm)	TABLE ANGLE (Degree)	REMARK
5400	42.98	34.26	54	-11.02	34.32	8.44	34.04	111	185	Average
5400	58.13	49.41	74	-15.87	34.32	8.44	34.04	111	185	Peak
5470	56.12	47.29	68.2	-12.08	34.37	8.51	34.05	111	185	Peak
5500	89.85	80.93			34.4	8.57	34.05	111	185	Average
5500	97.04	88.12			34.4	8.57	34.05	111	185	Peak
5725	56.58	47.42	68.2	-11.62	34.62	8.65	34.11	111	185	Peak

ANTENNA POLARITY & TEST DISTANCE: VERTICAL AT 3 M										
FREQ. (MHz)	EMISSION LEVEL (dBuV/m)	READ LEVEL (dBuV)	LIMIT (dBuV/m)	MARGIN (dB)	ANTENNA FACTOR (dB/m)	CABLE LOSS (dB)	PREAMP FACTOR (dB)	ANTENNA HEIGHT (cm)	TABLE ANGLE (Degree)	REMARK
5388	44.15	35.47	54	-9.85	34.31	8.41	34.04	108	149	Average
5388	57.8	49.12	74	-16.2	34.31	8.41	34.04	108	149	Peak
5470	55.74	46.91	68.2	-12.46	34.37	8.51	34.05	108	149	Peak
5500	97.61	88.69			34.4	8.57	34.05	108	149	Average
5500	105.49	96.57			34.4	8.57	34.05	108	149	Peak
5725	56.26	47.1	68.2	-11.94	34.62	8.65	34.11	108	149	Peak

REMARKS:

- Emission Level = Read Level + Antenna Factor + Cable Loss - Preamp Factor
Margin value = Emission level – Limit value
- 5500MHz: Fundamental frequency.
- 5470MHz & 5725MHz: Out of restricted band



A D T

EUT TEST CONDITION		MEASUREMENT DETAIL	
CHANNEL	Channel 116	FREQUENCY RANGE	1GHz ~ 40GHz
INPUT POWER	120Vac, 60 Hz	DETECTOR FUNCTION	Peak (PK) Average (AV)
ENVIRONMENTAL CONDITIONS	25deg. C, 65%RH	TESTED BY	Karl Lee

ANTENNA POLARITY & TEST DISTANCE: HORIZONTAL AT 3 M										
FREQ. (MHz)	EMISSION LEVEL (dBuV/m)	READ LEVEL (dBuV)	LIMIT (dBuV/m)	MARGIN (dB)	ANTENNA FACTOR (dB/m)	CABLE LOSS (dB)	PREAMP FACTOR (dB)	ANTENNA HEIGHT (cm)	TABLE ANGLE (Degree)	REMARK
5450	43.02	34.2	54	-10.98	34.36	8.51	34.05	110	192	Average
5450	56.66	47.84	74	-17.34	34.36	8.51	34.05	110	192	Peak
5470	55.47	46.64	68.2	-12.73	34.37	8.51	34.05	110	192	Peak
5580	91.22	82.23			34.47	8.6	34.08	110	192	Average
5580	99.87	90.88			34.47	8.6	34.08	110	192	Peak
5725	55.01	45.85	68.2	-13.19	34.62	8.65	34.11	110	192	Peak

ANTENNA POLARITY & TEST DISTANCE: VERTICAL AT 3 M										
FREQ. (MHz)	EMISSION LEVEL (dBuV/m)	READ LEVEL (dBuV)	LIMIT (dBuV/m)	MARGIN (dB)	ANTENNA FACTOR (dB/m)	CABLE LOSS (dB)	PREAMP FACTOR (dB)	ANTENNA HEIGHT (cm)	TABLE ANGLE (Degree)	REMARK
5456	42.9	34.08	54	-11.1	34.36	8.51	34.05	106	179	Average
5456	56.86	48.04	74	-17.14	34.36	8.51	34.05	106	179	Peak
5470	56.28	47.45	68.2	-11.92	34.37	8.51	34.05	106	179	Peak
5580	99.1	90.11			34.47	8.6	34.08	106	179	Average
5580	107.51	98.52			34.47	8.6	34.08	106	179	Peak
5725	56.74	47.58	68.2	-11.46	34.62	8.65	34.11	106	179	Peak

REMARKS:

- Emission Level = Read Level + Antenna Factor + Cable Loss - Preamp Factor
Margin value = Emission level – Limit value
- 5580MHz: Fundamental frequency.
- 5470MHz & 5725MHz: Out of restricted band



A D T

EUT TEST CONDITION		MEASUREMENT DETAIL	
CHANNEL	Channel 140	FREQUENCY RANGE	1GHz ~ 40GHz
INPUT POWER	120Vac, 60 Hz	DETECTOR FUNCTION	Peak (PK) Average (AV)
ENVIRONMENTAL CONDITIONS	25deg. C, 65%RH	TESTED BY	Karl Lee

ANTENNA POLARITY & TEST DISTANCE: HORIZONTAL AT 3 M										
FREQ. (MHz)	EMISSION LEVEL (dBuV/m)	READ LEVEL (dBuV)	LIMIT (dBuV/m)	MARGIN (dB)	ANTENNA FACTOR (dB/m)	CABLE LOSS (dB)	PREAMP FACTOR (dB)	ANTENNA HEIGHT (cm)	TABLE ANGLE (Degree)	REMARK
5376	42.69	34.03	54	-11.31	34.29	8.41	34.04	107	339	Average
5376	57.11	48.45	74	-16.89	34.29	8.41	34.04	107	339	Peak
5470	56.2	47.37	68.2	-12	34.37	8.51	34.05	107	339	Peak
5700	88.5	79.37			34.59	8.64	34.1	107	339	Average
5700	96.68	87.55			34.59	8.64	34.1	107	339	Peak
5725	55.66	46.5	68.2	-12.54	34.62	8.65	34.11	107	339	Peak
ANTENNA POLARITY & TEST DISTANCE: VERTICAL AT 3 M										
FREQ. (MHz)	EMISSION LEVEL (dBuV/m)	READ LEVEL (dBuV)	LIMIT (dBuV/m)	MARGIN (dB)	ANTENNA FACTOR (dB/m)	CABLE LOSS (dB)	PREAMP FACTOR (dB)	ANTENNA HEIGHT (cm)	TABLE ANGLE (Degree)	REMARK
5430	42.9	34.11	54	-11.1	34.35	8.48	34.04	104	169	Average
5430	58.27	49.48	74	-15.73	34.35	8.48	34.04	104	169	Peak
5470	56.33	47.5	68.2	-11.87	34.37	8.51	34.05	104	169	Peak
5700	96.18	87.05			34.59	8.64	34.1	104	169	Average
5700	104.97	95.84			34.59	8.64	34.1	104	169	Peak
5725	57.94	48.78	68.2	-10.26	34.62	8.65	34.11	104	169	Peak

REMARKS:

- Emission Level = Read Level + Antenna Factor + Cable Loss - Preamp Factor
Margin value = Emission level – Limit value
- 5700MHz: Fundamental frequency.
- 5470MHz & 5725MHz: Out of restricted band



A D T

EUT TEST CONDITION		MEASUREMENT DETAIL	
CHANNEL	Channel 149	FREQUENCY RANGE	1GHz ~ 40GHz
INPUT POWER	120Vac, 60 Hz	DETECTOR FUNCTION	Peak (PK) Average (AV)
ENVIRONMENTAL CONDITIONS	25deg. C, 65%RH	TESTED BY	Karl Lee

ANTENNA POLARITY & TEST DISTANCE: HORIZONTAL AT 3 M										
FREQ. (MHz)	EMISSION LEVEL (dBuV/m)	READ LEVEL (dBuV)	LIMIT (dBuV/m)	MARGIN (dB)	ANTENNA FACTOR (dB/m)	CABLE LOSS (dB)	PREAMP FACTOR (dB)	ANTENNA HEIGHT (cm)	TABLE ANGLE (Degree)	REMARK
*5712	56.67	47.52	68.2	-11.53	34.61	8.65	34.11	172	29	Peak
*5724	61.32	52.16	78.2	-16.88	34.62	8.65	34.11	172	29	Peak
5745	96.45	87.26			34.64	8.66	34.11	172	29	Average
5745	104.43	95.24			34.64	8.66	34.11	172	29	Peak
*5854	56.69	47.37	78.2	-21.51	34.76	8.7	34.14	172	29	Peak
*5866	56.22	46.89	68.2	-11.98	34.76	8.71	34.14	172	29	Peak
ANTENNA POLARITY & TEST DISTANCE: VERTICAL AT 3 M										
FREQ. (MHz)	EMISSION LEVEL (dBuV/m)	READ LEVEL (dBuV)	LIMIT (dBuV/m)	MARGIN (dB)	ANTENNA FACTOR (dB/m)	CABLE LOSS (dB)	PREAMP FACTOR (dB)	ANTENNA HEIGHT (cm)	TABLE ANGLE (Degree)	REMARK
*5706	56.54	47.39	68.2	-11.66	34.61	8.65	34.11	100	322	Peak
*5724	59.04	49.88	78.2	-19.16	34.62	8.65	34.11	100	322	Peak
5745	95.95	86.76			34.64	8.66	34.11	100	322	Average
5745	103.37	94.18			34.64	8.66	34.11	100	322	Peak
*5858	56.88	47.56	78.2	-21.32	34.76	8.7	34.14	100	322	Peak
*5862	56.97	47.64	68.2	-11.23	34.76	8.71	34.14	100	322	Peak

REMARKS:

- Emission Level = Read Level + Antenna Factor + Cable Loss - Preamp Factor
Margin value = Emission level – Limit value
- 5745MHz: Fundamental frequency.
- *: Out of restricted band



A D T

EUT TEST CONDITION		MEASUREMENT DETAIL	
CHANNEL	Channel 157	FREQUENCY RANGE	1GHz ~ 40GHz
INPUT POWER	120Vac, 60 Hz	DETECTOR FUNCTION	Peak (PK) Average (AV)
ENVIRONMENTAL CONDITIONS	25deg. C, 65%RH	TESTED BY	Karl Lee

ANTENNA POLARITY & TEST DISTANCE: HORIZONTAL AT 3 M

FREQ. (MHz)	EMISSION LEVEL (dBuV/m)	READ LEVEL (dBuV)	LIMIT (dBuV/m)	MARGIN (dB)	ANTENNA FACTOR (dB/m)	CABLE LOSS (dB)	PREAMP FACTOR (dB)	ANTENNA HEIGHT (cm)	TABLE ANGLE (Degree)	REMARK
*5712	57.87	48.72	68.2	-10.33	34.61	8.65	34.11	196	32	Peak
*5724	58.91	49.75	78.2	-19.29	34.62	8.65	34.11	196	32	Peak
5785	99.88	90.65			34.68	8.68	34.13	196	32	Average
5785	107.3	98.07			34.68	8.68	34.13	196	32	Peak
*5858	57.79	48.47	78.2	-20.41	34.76	8.7	34.14	196	32	Peak
*5862	58.31	48.98	68.2	-9.89	34.76	8.71	34.14	196	32	Peak

ANTENNA POLARITY & TEST DISTANCE: VERTICAL AT 3 M

FREQ. (MHz)	EMISSION LEVEL (dBuV/m)	READ LEVEL (dBuV)	LIMIT (dBuV/m)	MARGIN (dB)	ANTENNA FACTOR (dB/m)	CABLE LOSS (dB)	PREAMP FACTOR (dB)	ANTENNA HEIGHT (cm)	TABLE ANGLE (Degree)	REMARK
*5714	57.67	48.52	68.2	-10.53	34.61	8.65	34.11	100	328	Peak
*5718	59.58	50.42	78.2	-18.62	34.62	8.65	34.11	100	328	Peak
5785	98.48	89.25			34.68	8.68	34.13	100	328	Average
5785	106.8	97.57			34.68	8.68	34.13	100	328	Peak
*5860	57.45	48.13	78.2	-20.75	34.76	8.7	34.14	100	328	Peak
*5864	58.26	48.93	68.2	-9.94	34.76	8.71	34.14	100	328	Peak

REMARKS:

- Emission Level = Read Level + Antenna Factor + Cable Loss - Preamp Factor
Margin value = Emission level – Limit value
- 5785MHz: Fundamental frequency.
- *: Out of restricted band



A D T

EUT TEST CONDITION		MEASUREMENT DETAIL	
CHANNEL	Channel 165	FREQUENCY RANGE	1GHz ~ 40GHz
INPUT POWER	120Vac, 60 Hz	DETECTOR FUNCTION	Peak (PK) Average (AV)
ENVIRONMENTAL CONDITIONS	25deg. C, 65%RH	TESTED BY	Karl Lee

ANTENNA POLARITY & TEST DISTANCE: HORIZONTAL AT 3 M

FREQ. (MHz)	EMISSION LEVEL (dBuV/m)	READ LEVEL (dBuV)	LIMIT (dBuV/m)	MARGIN (dB)	ANTENNA FACTOR (dB/m)	CABLE LOSS (dB)	PREAMP FACTOR (dB)	ANTENNA HEIGHT (cm)	TABLE ANGLE (Degree)	REMARK
*5714	58.02	48.87	68.2	-10.18	34.61	8.65	34.11	196	32	Peak
*5724	57	47.84	78.2	-21.2	34.62	8.65	34.11	196	32	Peak
5825	98.39	89.1			34.73	8.69	34.13	196	32	Average
5825	106.57	97.28			34.73	8.69	34.13	196	32	Peak
*5856	57.29	47.97	78.2	-20.91	34.76	8.7	34.14	196	32	Peak
*5866	58.31	48.98	68.2	-9.89	34.76	8.71	34.14	196	32	Peak

ANTENNA POLARITY & TEST DISTANCE: VERTICAL AT 3 M

FREQ. (MHz)	EMISSION LEVEL (dBuV/m)	READ LEVEL (dBuV)	LIMIT (dBuV/m)	MARGIN (dB)	ANTENNA FACTOR (dB/m)	CABLE LOSS (dB)	PREAMP FACTOR (dB)	ANTENNA HEIGHT (cm)	TABLE ANGLE (Degree)	REMARK
*5712	57	47.85	68.2	-11.2	34.61	8.65	34.11	117	332	Peak
*5716	57.17	48.02	78.2	-21.03	34.61	8.65	34.11	117	332	Peak
5825	97.5	88.21			34.73	8.69	34.13	117	332	Average
5825	105.79	96.5			34.73	8.69	34.13	117	332	Peak
*5852	57.52	48.22	78.2	-20.68	34.74	8.7	34.14	117	332	Peak
*5868	57.41	48.08	68.2	-10.79	34.76	8.71	34.14	117	332	Peak

REMARKS:

- Emission Level = Read Level + Antenna Factor + Cable Loss - Preamp Factor
Margin value = Emission level – Limit value
- 5825MHz: Fundamental frequency.
- *: Out of restricted band



A D T

802.11n (20MHz)

EUT TEST CONDITION		MEASUREMENT DETAIL	
CHANNEL	Channel 36	FREQUENCY RANGE	1GHz ~ 40GHz
INPUT POWER	120Vac, 60 Hz	DETECTOR FUNCTION	Peak (PK) Average (AV)
ENVIRONMENTAL CONDITIONS	25deg. C, 65%RH	TESTED BY	Karl Lee

ANTENNA POLARITY & TEST DISTANCE: HORIZONTAL AT 3 M										
FREQ. (MHz)	EMISSION LEVEL (dBuV/m)	READ LEVEL (dBuV)	LIMIT (dBuV/m)	MARGIN (dB)	ANTENNA FACTOR (dB/m)	CABLE LOSS (dB)	PREAMP FACTOR (dB)	ANTENNA HEIGHT (cm)	TABLE ANGLE (Degree)	REMARK
5092	42.65	34.48	54	-11.35	34.08	8.07	33.98	200	142	Average
5092	57	48.83	74	-17	34.08	8.07	33.98	200	142	Peak
5180	89.51	81.2			34.15	8.16	34	200	142	Average
5180	97.64	89.33			34.15	8.16	34	200	142	Peak
5444	42.92	34.13	54	-11.08	34.35	8.48	34.04	200	142	Average
5444	57.08	48.29	74	-16.92	34.35	8.48	34.04	200	142	Peak
ANTENNA POLARITY & TEST DISTANCE: VERTICAL AT 3 M										
FREQ. (MHz)	EMISSION LEVEL (dBuV/m)	READ LEVEL (dBuV)	LIMIT (dBuV/m)	MARGIN (dB)	ANTENNA FACTOR (dB/m)	CABLE LOSS (dB)	PREAMP FACTOR (dB)	ANTENNA HEIGHT (cm)	TABLE ANGLE (Degree)	REMARK
5128	44	35.78	54	-10	34.11	8.1	33.99	101	211	Average
5128	57.15	48.93	74	-16.85	34.11	8.1	33.99	101	211	Peak
5180	97.51	89.2			34.15	8.16	34	101	211	Average
5180	105.44	97.13			34.15	8.16	34	101	211	Peak
5350	42.66	34.03	54	-11.34	34.28	8.38	34.03	101	211	Average
5350	57.73	49.1	74	-16.27	34.28	8.38	34.03	101	211	Peak

REMARKS:

- Emission Level = Read Level + Antenna Factor + Cable Loss - Preamp Factor
Margin value = Emission level – Limit value
- 5180MHz: Fundamental frequency.



A D T

EUT TEST CONDITION		MEASUREMENT DETAIL	
CHANNEL	Channel 44	FREQUENCY RANGE	1GHz ~ 40GHz
INPUT POWER	120Vac, 60 Hz	DETECTOR FUNCTION	Peak (PK) Average (AV)
ENVIRONMENTAL CONDITIONS	25deg. C, 65%RH	TESTED BY	Karl Lee

ANTENNA POLARITY & TEST DISTANCE: HORIZONTAL AT 3 M										
FREQ. (MHz)	EMISSION LEVEL (dBuV/m)	READ LEVEL (dBuV)	LIMIT (dBuV/m)	MARGIN (dB)	ANTENNA FACTOR (dB/m)	CABLE LOSS (dB)	PREAMP FACTOR (dB)	ANTENNA HEIGHT (cm)	TABLE ANGLE (Degree)	REMARK
5112	42.49	34.29	54	-11.51	34.09	8.1	33.99	211	142	Average
5112	57.09	48.89	74	-16.91	34.09	8.1	33.99	211	142	Peak
5220	91.4	83.01			34.17	8.22	34	211	142	Average
5220	99.39	91			34.17	8.22	34	211	142	Peak
5438	42.82	34.03	54	-11.18	34.35	8.48	34.04	211	142	Average
5438	56.97	48.18	74	-17.03	34.35	8.48	34.04	211	142	Peak
ANTENNA POLARITY & TEST DISTANCE: VERTICAL AT 3 M										
FREQ. (MHz)	EMISSION LEVEL (dBuV/m)	READ LEVEL (dBuV)	LIMIT (dBuV/m)	MARGIN (dB)	ANTENNA FACTOR (dB/m)	CABLE LOSS (dB)	PREAMP FACTOR (dB)	ANTENNA HEIGHT (cm)	TABLE ANGLE (Degree)	REMARK
5150	42.75	34.5	54	-11.25	34.12	8.13	34	100	211	Average
5150	57.24	48.99	74	-16.76	34.12	8.13	34	100	211	Peak
5220	99.78	91.39			34.17	8.22	34	100	211	Average
5220	107.87	99.48			34.17	8.22	34	100	211	Peak
5366	42.77	34.13	54	-11.23	34.29	8.38	34.03	100	211	Average
5366	57.99	49.35	74	-16.01	34.29	8.38	34.03	100	211	Peak

REMARKS:

- Emission Level = Read Level + Antenna Factor + Cable Loss - Preamp Factor
Margin value = Emission level – Limit value
- 5220MHz: Fundamental frequency.



A D T

EUT TEST CONDITION		MEASUREMENT DETAIL	
CHANNEL	Channel 48	FREQUENCY RANGE	1GHz ~ 40GHz
INPUT POWER	120Vac, 60 Hz	DETECTOR FUNCTION	Peak (PK) Average (AV)
ENVIRONMENTAL CONDITIONS	25deg. C, 65%RH	TESTED BY	Karl Lee

ANTENNA POLARITY & TEST DISTANCE: HORIZONTAL AT 3 M										
FREQ. (MHz)	EMISSION LEVEL (dBuV/m)	READ LEVEL (dBuV)	LIMIT (dBuV/m)	MARGIN (dB)	ANTENNA FACTOR (dB/m)	CABLE LOSS (dB)	PREAMP FACTOR (dB)	ANTENNA HEIGHT (cm)	TABLE ANGLE (Degree)	REMARK
5140	42.65	34.39	54	-11.35	34.12	8.13	33.99	208	142	Average
5140	57.47	49.21	74	-16.53	34.12	8.13	33.99	208	142	Peak
5240	91.14	82.7			34.19	8.26	34.01	208	142	Average
5240	99.42	90.98			34.19	8.26	34.01	208	142	Peak
5426	42.91	34.14	54	-11.09	34.33	8.48	34.04	208	142	Average
5426	57.54	48.77	74	-16.46	34.33	8.48	34.04	208	142	Peak

ANTENNA POLARITY & TEST DISTANCE: VERTICAL AT 3 M										
FREQ. (MHz)	EMISSION LEVEL (dBuV/m)	READ LEVEL (dBuV)	LIMIT (dBuV/m)	MARGIN (dB)	ANTENNA FACTOR (dB/m)	CABLE LOSS (dB)	PREAMP FACTOR (dB)	ANTENNA HEIGHT (cm)	TABLE ANGLE (Degree)	REMARK
5038	42.54	34.47	54	-11.46	34.04	8	33.97	100	211	Average
5038	56.46	48.39	74	-17.54	34.04	8	33.97	100	211	Peak
5240	99.14	90.7			34.19	8.26	34.01	100	211	Average
5240	107.04	98.6			34.19	8.26	34.01	100	211	Peak
5444	43.07	34.28	54	-10.93	34.35	8.48	34.04	100	211	Average
5444	58.55	49.76	74	-15.45	34.35	8.48	34.04	100	211	Peak

REMARKS:

- Emission Level = Read Level + Antenna Factor + Cable Loss - Preamp Factor
Margin value = Emission level – Limit value
- 5240MHz: Fundamental frequency.



A D T

EUT TEST CONDITION		MEASUREMENT DETAIL	
CHANNEL	Channel 52	FREQUENCY RANGE	1GHz ~ 40GHz
INPUT POWER	120Vac, 60 Hz	DETECTOR FUNCTION	Peak (PK) Average (AV)
ENVIRONMENTAL CONDITIONS	25deg. C, 65%RH	TESTED BY	Karl Lee

ANTENNA POLARITY & TEST DISTANCE: HORIZONTAL AT 3 M										
FREQ. (MHz)	EMISSION LEVEL (dBuV/m)	READ LEVEL (dBuV)	LIMIT (dBuV/m)	MARGIN (dB)	ANTENNA FACTOR (dB/m)	CABLE LOSS (dB)	PREAMP FACTOR (dB)	ANTENNA HEIGHT (cm)	TABLE ANGLE (Degree)	REMARK
5060	42.49	34.39	54	-11.51	34.05	8.03	33.98	199	135	Average
5060	57.39	49.29	74	-16.61	34.05	8.03	33.98	199	135	Peak
5260	91.07	82.61			34.21	8.26	34.01	199	135	Average
5260	99.05	90.59			34.21	8.26	34.01	199	135	Peak
5350	43.16	34.53	54	-10.84	34.28	8.38	34.03	199	135	Average
5350	57.93	49.3	74	-16.07	34.28	8.38	34.03	199	135	Peak

ANTENNA POLARITY & TEST DISTANCE: VERTICAL AT 3 M										
FREQ. (MHz)	EMISSION LEVEL (dBuV/m)	READ LEVEL (dBuV)	LIMIT (dBuV/m)	MARGIN (dB)	ANTENNA FACTOR (dB/m)	CABLE LOSS (dB)	PREAMP FACTOR (dB)	ANTENNA HEIGHT (cm)	TABLE ANGLE (Degree)	REMARK
5100	42.35	34.19	54	-11.65	34.08	8.07	33.99	114	204	Average
5100	57.91	49.75	74	-16.09	34.08	8.07	33.99	114	204	Peak
5260	99.67	91.21			34.21	8.26	34.01	114	204	Average
5260	107.39	98.93			34.21	8.26	34.01	114	204	Peak
5436	42.92	34.13	54	-11.08	34.35	8.48	34.04	114	204	Average
5436	56.75	47.96	74	-17.25	34.35	8.48	34.04	114	204	Peak

REMARKS:

- Emission Level = Read Level + Antenna Factor + Cable Loss - Preamp Factor
Margin value = Emission level – Limit value
- 5260MHz: Fundamental frequency.



A D T

EUT TEST CONDITION		MEASUREMENT DETAIL	
CHANNEL	Channel 60	FREQUENCY RANGE	1GHz ~ 40GHz
INPUT POWER	120Vac, 60 Hz	DETECTOR FUNCTION	Peak (PK) Average (AV)
ENVIRONMENTAL CONDITIONS	25deg. C, 65%RH	TESTED BY	Karl Lee

ANTENNA POLARITY & TEST DISTANCE: HORIZONTAL AT 3 M										
FREQ. (MHz)	EMISSION LEVEL (dBuV/m)	READ LEVEL (dBuV)	LIMIT (dBuV/m)	MARGIN (dB)	ANTENNA FACTOR (dB/m)	CABLE LOSS (dB)	PREAMP FACTOR (dB)	ANTENNA HEIGHT (cm)	TABLE ANGLE (Degree)	REMARK
5036	42.33	34.27	54	-11.67	34.03	8	33.97	217	135	Average
5036	56.27	48.21	74	-17.73	34.03	8	33.97	217	135	Peak
5300	91.06	82.52			34.24	8.32	34.02	217	135	Average
5300	99.04	90.5			34.24	8.32	34.02	217	135	Peak
5368	42.91	34.24	54	-11.09	34.29	8.41	34.03	217	135	Average
5368	56.57	47.9	74	-17.43	34.29	8.41	34.03	217	135	Peak

ANTENNA POLARITY & TEST DISTANCE: VERTICAL AT 3 M										
FREQ. (MHz)	EMISSION LEVEL (dBuV/m)	READ LEVEL (dBuV)	LIMIT (dBuV/m)	MARGIN (dB)	ANTENNA FACTOR (dB/m)	CABLE LOSS (dB)	PREAMP FACTOR (dB)	ANTENNA HEIGHT (cm)	TABLE ANGLE (Degree)	REMARK
5098	42.65	34.49	54	-11.35	34.08	8.07	33.99	128	204	Average
5098	57.07	48.91	74	-16.93	34.08	8.07	33.99	128	204	Peak
5300	99.66	91.12			34.24	8.32	34.02	128	204	Average
5300	107.56	99.02			34.24	8.32	34.02	128	204	Peak
5382	44.92	36.24	54	-9.08	34.31	8.41	34.04	128	204	Average
5382	57.63	48.95	74	-16.37	34.31	8.41	34.04	128	204	Peak

REMARKS:

- Emission Level = Read Level + Antenna Factor + Cable Loss - Preamp Factor
Margin value = Emission level – Limit value
- 5300MHz: Fundamental frequency.



A D T

EUT TEST CONDITION		MEASUREMENT DETAIL	
CHANNEL	Channel 64	FREQUENCY RANGE	1GHz ~ 40GHz
INPUT POWER	120Vac, 60 Hz	DETECTOR FUNCTION	Peak (PK) Average (AV)
ENVIRONMENTAL CONDITIONS	25deg. C, 65%RH	TESTED BY	Karl Lee

ANTENNA POLARITY & TEST DISTANCE: HORIZONTAL AT 3 M										
FREQ. (MHz)	EMISSION LEVEL (dBuV/m)	READ LEVEL (dBuV)	LIMIT (dBuV/m)	MARGIN (dB)	ANTENNA FACTOR (dB/m)	CABLE LOSS (dB)	PREAMP FACTOR (dB)	ANTENNA HEIGHT (cm)	TABLE ANGLE (Degree)	REMARK
5150	42.75	34.5	54	-11.25	34.12	8.13	34	215	141	Average
5150	57.22	48.97	74	-16.78	34.12	8.13	34	215	141	Peak
5320	91.3	82.72			34.25	8.35	34.02	215	141	Average
5320	99.1	90.52			34.25	8.35	34.02	215	141	Peak
5386	42.72	34.04	54	-11.28	34.31	8.41	34.04	215	141	Average
5386	57.08	48.4	74	-16.92	34.31	8.41	34.04	215	141	Peak
ANTENNA POLARITY & TEST DISTANCE: VERTICAL AT 3 M										
FREQ. (MHz)	EMISSION LEVEL (dBuV/m)	READ LEVEL (dBuV)	LIMIT (dBuV/m)	MARGIN (dB)	ANTENNA FACTOR (dB/m)	CABLE LOSS (dB)	PREAMP FACTOR (dB)	ANTENNA HEIGHT (cm)	TABLE ANGLE (Degree)	REMARK
5038	42.54	34.47	54	-11.46	34.04	8	33.97	134	206	Average
5038	57.17	49.1	74	-16.83	34.04	8	33.97	134	206	Peak
5320	99.1	90.52			34.25	8.35	34.02	134	206	Average
5320	107.43	98.85			34.25	8.35	34.02	134	206	Peak
5426	45.11	36.34	54	-8.89	34.33	8.48	34.04	134	206	Average
5426	58.14	49.37	74	-15.86	34.33	8.48	34.04	134	206	Peak

REMARKS:

- Emission Level = Read Level + Antenna Factor + Cable Loss - Preamp Factor
Margin value = Emission level – Limit value
- 5320MHz: Fundamental frequency.



A D T

EUT TEST CONDITION		MEASUREMENT DETAIL	
CHANNEL	Channel 100	FREQUENCY RANGE	1GHz ~ 40GHz
INPUT POWER	120Vac, 60 Hz	DETECTOR FUNCTION	Peak (PK) Average (AV)
ENVIRONMENTAL CONDITIONS	25deg. C, 65%RH	TESTED BY	Karl Lee

ANTENNA POLARITY & TEST DISTANCE: HORIZONTAL AT 3 M										
FREQ. (MHz)	EMISSION LEVEL (dBuV/m)	READ LEVEL (dBuV)	LIMIT (dBuV/m)	MARGIN (dB)	ANTENNA FACTOR (dB/m)	CABLE LOSS (dB)	PREAMP FACTOR (dB)	ANTENNA HEIGHT (cm)	TABLE ANGLE (Degree)	REMARK
5428	43.13	34.36	54	-10.87	34.33	8.48	34.04	111	185	Average
5428	57.57	48.8	74	-16.43	34.33	8.48	34.04	111	185	Peak
5470	55.64	46.81	68.2	-12.56	34.37	8.51	34.05	111	185	Peak
5500	89.96	81.04			34.4	8.57	34.05	111	185	Average
5500	97.25	88.33			34.4	8.57	34.05	111	185	Peak
5725	55.15	45.99	68.2	-13.05	34.62	8.65	34.11	111	185	Peak

ANTENNA POLARITY & TEST DISTANCE: VERTICAL AT 3 M										
FREQ. (MHz)	EMISSION LEVEL (dBuV/m)	READ LEVEL (dBuV)	LIMIT (dBuV/m)	MARGIN (dB)	ANTENNA FACTOR (dB/m)	CABLE LOSS (dB)	PREAMP FACTOR (dB)	ANTENNA HEIGHT (cm)	TABLE ANGLE (Degree)	REMARK
5424	44.43	35.66	54	-9.57	34.33	8.48	34.04	108	151	Average
5424	57.2	48.43	74	-16.8	34.33	8.48	34.04	108	151	Peak
5470	55.91	47.08	68.2	-12.29	34.37	8.51	34.05	108	151	Peak
5500	97.5	88.58			34.4	8.57	34.05	108	151	Average
5500	105.88	96.96			34.4	8.57	34.05	108	151	Peak
5725	55.55	46.39	68.2	-12.65	34.62	8.65	34.11	108	151	Peak

REMARKS:

- Emission Level = Read Level + Antenna Factor + Cable Loss - Preamp Factor
Margin value = Emission level – Limit value
- 5500MHz: Fundamental frequency.
- 5470MHz & 5725MHz: Out of restricted band



A D T

EUT TEST CONDITION		MEASUREMENT DETAIL	
CHANNEL	Channel 116	FREQUENCY RANGE	1GHz ~ 40GHz
INPUT POWER	120Vac, 60 Hz	DETECTOR FUNCTION	Peak (PK) Average (AV)
ENVIRONMENTAL CONDITIONS	25deg. C, 65%RH	TESTED BY	Karl Lee

ANTENNA POLARITY & TEST DISTANCE: HORIZONTAL AT 3 M										
FREQ. (MHz)	EMISSION LEVEL (dBuV/m)	READ LEVEL (dBuV)	LIMIT (dBuV/m)	MARGIN (dB)	ANTENNA FACTOR (dB/m)	CABLE LOSS (dB)	PREAMP FACTOR (dB)	ANTENNA HEIGHT (cm)	TABLE ANGLE (Degree)	REMARK
5398	42.86	34.14	54	-11.14	34.32	8.44	34.04	110	192	Average
5398	57.46	48.74	74	-16.54	34.32	8.44	34.04	110	192	Peak
5470	55.39	46.56	68.2	-12.81	34.37	8.51	34.05	110	192	Peak
5580	91.52	82.53			34.47	8.6	34.08	110	192	Average
5580	99.03	90.04			34.47	8.6	34.08	110	192	Peak
5725	55.3	46.14	68.2	-12.9	34.62	8.65	34.11	110	192	Peak
ANTENNA POLARITY & TEST DISTANCE: VERTICAL AT 3 M										
FREQ. (MHz)	EMISSION LEVEL (dBuV/m)	READ LEVEL (dBuV)	LIMIT (dBuV/m)	MARGIN (dB)	ANTENNA FACTOR (dB/m)	CABLE LOSS (dB)	PREAMP FACTOR (dB)	ANTENNA HEIGHT (cm)	TABLE ANGLE (Degree)	REMARK
5448	42.9	34.07	54	-11.1	34.36	8.51	34.04	106	178	Average
5448	57.62	48.79	74	-16.38	34.36	8.51	34.04	106	178	Peak
5470	55.46	46.63	68.2	-12.74	34.37	8.51	34.05	106	178	Peak
5580	99.95	90.96			34.47	8.6	34.08	106	178	Average
5580	107.5	98.51			34.47	8.6	34.08	106	178	Peak
5725	56.56	47.4	68.2	-11.64	34.62	8.65	34.11	106	178	Peak

REMARKS:

- Emission Level = Read Level + Antenna Factor + Cable Loss - Preamp Factor
Margin value = Emission level – Limit value
- 5580MHz: Fundamental frequency.
- 5470MHz & 5725MHz: Out of restricted band



A D T

EUT TEST CONDITION		MEASUREMENT DETAIL	
CHANNEL	Channel 140	FREQUENCY RANGE	1GHz ~ 40GHz
INPUT POWER	120Vac, 60 Hz	DETECTOR FUNCTION	Peak (PK) Average (AV)
ENVIRONMENTAL CONDITIONS	25deg. C, 65%RH	TESTED BY	Karl Lee

ANTENNA POLARITY & TEST DISTANCE: HORIZONTAL AT 3 M										
FREQ. (MHz)	EMISSION LEVEL (dBuV/m)	READ LEVEL (dBuV)	LIMIT (dBuV/m)	MARGIN (dB)	ANTENNA FACTOR (dB/m)	CABLE LOSS (dB)	PREAMP FACTOR (dB)	ANTENNA HEIGHT (cm)	TABLE ANGLE (Degree)	REMARK
5438	42.8	34.01	54	-11.2	34.35	8.48	34.04	107	339	Average
5438	57.18	48.39	74	-16.82	34.35	8.48	34.04	107	339	Peak
5470	55.86	47.03	68.2	-12.34	34.37	8.51	34.05	107	339	Peak
5700	88.58	79.45			34.59	8.64	34.1	107	339	Average
5700	96.3	87.17			34.59	8.64	34.1	107	339	Peak
5725	56.51	47.35	68.2	-11.69	34.62	8.65	34.11	107	339	Peak

ANTENNA POLARITY & TEST DISTANCE: VERTICAL AT 3 M										
FREQ. (MHz)	EMISSION LEVEL (dBuV/m)	READ LEVEL (dBuV)	LIMIT (dBuV/m)	MARGIN (dB)	ANTENNA FACTOR (dB/m)	CABLE LOSS (dB)	PREAMP FACTOR (dB)	ANTENNA HEIGHT (cm)	TABLE ANGLE (Degree)	REMARK
5412	43.4	34.67	54	-10.6	34.33	8.44	34.04	104	169	Average
5412	57.53	48.8	74	-16.47	34.33	8.44	34.04	104	169	Peak
5470	56.71	47.88	68.2	-11.49	34.37	8.51	34.05	104	169	Peak
5700	96.08	86.95			34.59	8.64	34.1	104	169	Average
5700	104.39	95.26			34.59	8.64	34.1	104	169	Peak
5725	59.35	50.19	68.2	-8.85	34.62	8.65	34.11	104	169	Peak

REMARKS:

- Emission Level = Read Level + Antenna Factor + Cable Loss - Preamp Factor
Margin value = Emission level – Limit value
- 5700MHz: Fundamental frequency.
- 5470MHz & 5725MHz: Out of restricted band



A D T

EUT TEST CONDITION		MEASUREMENT DETAIL	
CHANNEL	Channel 149	FREQUENCY RANGE	1GHz ~ 40GHz
INPUT POWER	120Vac, 60 Hz	DETECTOR FUNCTION	Peak (PK) Average (AV)
ENVIRONMENTAL CONDITIONS	25deg. C, 65%RH	TESTED BY	Karl Lee

ANTENNA POLARITY & TEST DISTANCE: HORIZONTAL AT 3 M										
FREQ. (MHz)	EMISSION LEVEL (dBuV/m)	READ LEVEL (dBuV)	LIMIT (dBuV/m)	MARGIN (dB)	ANTENNA FACTOR (dB/m)	CABLE LOSS (dB)	PREAMP FACTOR (dB)	ANTENNA HEIGHT (cm)	TABLE ANGLE (Degree)	REMARK
*5714	57.67	48.52	68.2	-10.53	34.61	8.65	34.11	196	32	Peak
*5724	64.51	55.35	78.2	-13.69	34.62	8.65	34.11	196	32	Peak
5745	96.89	87.7			34.64	8.66	34.11	196	32	Average
5745	104.25	95.06			34.64	8.66	34.11	196	32	Peak
*5854	59.33	50.01	78.2	-18.87	34.76	8.7	34.14	196	32	Peak
*5864	57.64	48.31	68.2	-10.56	34.76	8.71	34.14	196	32	Peak
ANTENNA POLARITY & TEST DISTANCE: VERTICAL AT 3 M										
FREQ. (MHz)	EMISSION LEVEL (dBuV/m)	READ LEVEL (dBuV)	LIMIT (dBuV/m)	MARGIN (dB)	ANTENNA FACTOR (dB/m)	CABLE LOSS (dB)	PREAMP FACTOR (dB)	ANTENNA HEIGHT (cm)	TABLE ANGLE (Degree)	REMARK
*5706	57.44	48.29	68.2	-10.76	34.61	8.65	34.11	100	322	Peak
*5724	61.45	52.29	78.2	-16.75	34.62	8.65	34.11	100	322	Peak
5745	95.75	86.56			34.64	8.66	34.11	100	322	Average
5745	103.8	94.61			34.64	8.66	34.11	100	322	Peak
*5860	57.03	47.71	78.2	-21.17	34.76	8.7	34.14	100	322	Peak
*5868	58.25	48.92	68.2	-9.95	34.76	8.71	34.14	100	322	Peak

REMARKS:

- Emission Level = Read Level + Antenna Factor + Cable Loss - Preamp Factor
Margin value = Emission level – Limit value
- 5745MHz: Fundamental frequency.
- *: Out of restricted band



A D T

EUT TEST CONDITION		MEASUREMENT DETAIL	
CHANNEL	Channel 157	FREQUENCY RANGE	1GHz ~ 40GHz
INPUT POWER	120Vac, 60 Hz	DETECTOR FUNCTION	Peak (PK) Average (AV)
ENVIRONMENTAL CONDITIONS	25deg. C, 65%RH	TESTED BY	Karl Lee

ANTENNA POLARITY & TEST DISTANCE: HORIZONTAL AT 3 M

FREQ. (MHz)	EMISSION LEVEL (dBuV/m)	READ LEVEL (dBuV)	LIMIT (dBuV/m)	MARGIN (dB)	ANTENNA FACTOR (dB/m)	CABLE LOSS (dB)	PREAMP FACTOR (dB)	ANTENNA HEIGHT (cm)	TABLE ANGLE (Degree)	REMARK
*5712	56.55	47.4	68.2	-11.65	34.61	8.65	34.11	196	32	Peak
*5724	56.85	47.69	78.2	-21.35	34.62	8.65	34.11	196	32	Peak
5785	99.28	90.05			34.68	8.68	34.13	196	32	Average
5785	107.78	98.55			34.68	8.68	34.13	196	32	Peak
*5860	57.05	47.73	78.2	-21.15	34.76	8.7	34.14	196	32	Peak
*5868	56.87	47.54	68.2	-11.33	34.76	8.71	34.14	196	32	Peak

ANTENNA POLARITY & TEST DISTANCE: VERTICAL AT 3 M

FREQ. (MHz)	EMISSION LEVEL (dBuV/m)	READ LEVEL (dBuV)	LIMIT (dBuV/m)	MARGIN (dB)	ANTENNA FACTOR (dB/m)	CABLE LOSS (dB)	PREAMP FACTOR (dB)	ANTENNA HEIGHT (cm)	TABLE ANGLE (Degree)	REMARK
*5708	56.92	47.77	68.2	-11.28	34.61	8.65	34.11	100	328	Peak
*5716	56.84	47.69	78.2	-21.36	34.61	8.65	34.11	100	328	Peak
5785	98.93	89.7			34.68	8.68	34.13	100	328	Average
5785	106.72	97.49			34.68	8.68	34.13	100	328	Peak
*5852	57.02	47.72	78.2	-21.18	34.74	8.7	34.14	100	328	Peak
*5870	57.97	48.64	68.2	-10.23	34.76	8.71	34.14	100	328	Peak

REMARKS:

- Emission Level = Read Level + Antenna Factor + Cable Loss - Preamp Factor
Margin value = Emission level – Limit value
- 5785MHz: Fundamental frequency.
- *: Out of restricted band



A D T

EUT TEST CONDITION		MEASUREMENT DETAIL	
CHANNEL	Channel 165	FREQUENCY RANGE	1GHz ~ 40GHz
INPUT POWER	120Vac, 60 Hz	DETECTOR FUNCTION	Peak (PK) Average (AV)
ENVIRONMENTAL CONDITIONS	25deg. C, 65%RH	TESTED BY	Karl Lee

ANTENNA POLARITY & TEST DISTANCE: HORIZONTAL AT 3 M

FREQ. (MHz)	EMISSION LEVEL (dBuV/m)	READ LEVEL (dBuV)	LIMIT (dBuV/m)	MARGIN (dB)	ANTENNA FACTOR (dB/m)	CABLE LOSS (dB)	PREAMP FACTOR (dB)	ANTENNA HEIGHT (cm)	TABLE ANGLE (Degree)	REMARK
*5708	56.72	47.57	68.2	-11.48	34.61	8.65	34.11	196	32	Peak
*5716	56.87	47.72	78.2	-21.33	34.61	8.65	34.11	196	32	Peak
5825	98.33	89.04			34.73	8.69	34.13	196	32	Average
5825	106.04	96.75			34.73	8.69	34.13	196	32	Peak
*5860	58.3	48.98	78.2	-19.9	34.76	8.7	34.14	196	32	Peak
*5864	57.16	47.83	68.2	-11.04	34.76	8.71	34.14	196	32	Peak

ANTENNA POLARITY & TEST DISTANCE: VERTICAL AT 3 M

FREQ. (MHz)	EMISSION LEVEL (dBuV/m)	READ LEVEL (dBuV)	LIMIT (dBuV/m)	MARGIN (dB)	ANTENNA FACTOR (dB/m)	CABLE LOSS (dB)	PREAMP FACTOR (dB)	ANTENNA HEIGHT (cm)	TABLE ANGLE (Degree)	REMARK
*5712	59.27	50.12	68.2	-8.93	34.61	8.65	34.11	117	332	Peak
*5722	57.03	47.87	78.2	-21.17	34.62	8.65	34.11	117	332	Peak
5825	97.18	87.89			34.73	8.69	34.13	117	332	Average
5825	105.81	96.52			34.73	8.69	34.13	117	332	Peak
*5856	56.81	47.49	78.2	-21.39	34.76	8.7	34.14	117	332	Peak
*5862	56.9	47.57	68.2	-11.3	34.76	8.71	34.14	117	332	Peak

REMARKS:

- Emission Level = Read Level + Antenna Factor + Cable Loss - Preamp Factor
Margin value = Emission level – Limit value
- 5825MHz: Fundamental frequency.
- *: Out of restricted band



A D T

802.11n (40MHz)

EUT TEST CONDITION		MEASUREMENT DETAIL	
CHANNEL	Channel 38	FREQUENCY RANGE	1GHz ~ 40GHz
INPUT POWER	120Vac, 60 Hz	DETECTOR FUNCTION	Peak (PK) Average (AV)
ENVIRONMENTAL CONDITIONS	25deg. C, 65%RH	TESTED BY	Karl Lee

ANTENNA POLARITY & TEST DISTANCE: HORIZONTAL AT 3 M										
FREQ. (MHz)	EMISSION LEVEL (dBuV/m)	READ LEVEL (dBuV)	LIMIT (dBuV/m)	MARGIN (dB)	ANTENNA FACTOR (dB/m)	CABLE LOSS (dB)	PREAMP FACTOR (dB)	ANTENNA HEIGHT (cm)	TABLE ANGLE (Degree)	REMARK
5054	43.24	35.18	54	-10.76	34.04	8	33.98	200	142	Average
5054	57.56	49.5	74	-16.44	34.04	8	33.98	200	142	Peak
5190	87.74	79.4			34.15	8.19	34	200	142	Average
5190	95.06	86.72			34.15	8.19	34	200	142	Peak
5454	43.27	34.45	54	-10.73	34.36	8.51	34.05	200	142	Average
5454	57.92	49.1	74	-16.08	34.36	8.51	34.05	200	142	Peak
ANTENNA POLARITY & TEST DISTANCE: VERTICAL AT 3 M										
FREQ. (MHz)	EMISSION LEVEL (dBuV/m)	READ LEVEL (dBuV)	LIMIT (dBuV/m)	MARGIN (dB)	ANTENNA FACTOR (dB/m)	CABLE LOSS (dB)	PREAMP FACTOR (dB)	ANTENNA HEIGHT (cm)	TABLE ANGLE (Degree)	REMARK
5144	47.15	38.9	54	-6.85	34.12	8.13	34	101	211	Average
5144	58.52	50.27	74	-15.48	34.12	8.13	34	101	211	Peak
5190	95.94	87.6			34.15	8.19	34	101	211	Average
5190	103.36	95.02			34.15	8.19	34	101	211	Peak
5368	42.81	34.14	54	-11.19	34.29	8.41	34.03	101	211	Average
5368	57.62	48.95	74	-16.38	34.29	8.41	34.03	101	211	Peak

REMARKS:

- Emission Level = Read Level + Antenna Factor + Cable Loss - Preamp Factor
Margin value = Emission level – Limit value
- 5190MHz: Fundamental frequency.



A D T

EUT TEST CONDITION		MEASUREMENT DETAIL	
CHANNEL	Channel 46	FREQUENCY RANGE	1GHz ~ 40GHz
INPUT POWER	120Vac, 60 Hz	DETECTOR FUNCTION	Peak (PK) Average (AV)
ENVIRONMENTAL CONDITIONS	25deg. C, 65%RH	TESTED BY	Karl Lee

ANTENNA POLARITY & TEST DISTANCE: HORIZONTAL AT 3 M										
FREQ. (MHz)	EMISSION LEVEL (dBuV/m)	READ LEVEL (dBuV)	LIMIT (dBuV/m)	MARGIN (dB)	ANTENNA FACTOR (dB/m)	CABLE LOSS (dB)	PREAMP FACTOR (dB)	ANTENNA HEIGHT (cm)	TABLE ANGLE (Degree)	REMARK
5076	43.1	34.98	54	-10.9	34.07	8.03	33.98	208	142	Average
5076	56.68	48.56	74	-17.32	34.07	8.03	33.98	208	142	Peak
5230	89.51	81.11			34.19	8.22	34.01	208	142	Average
5230	97	88.6			34.19	8.22	34.01	208	142	Peak
5428	43.31	34.54	54	-10.69	34.33	8.48	34.04	208	142	Average
5428	57.32	48.55	74	-16.68	34.33	8.48	34.04	208	142	Peak
ANTENNA POLARITY & TEST DISTANCE: VERTICAL AT 3 M										
FREQ. (MHz)	EMISSION LEVEL (dBuV/m)	READ LEVEL (dBuV)	LIMIT (dBuV/m)	MARGIN (dB)	ANTENNA FACTOR (dB/m)	CABLE LOSS (dB)	PREAMP FACTOR (dB)	ANTENNA HEIGHT (cm)	TABLE ANGLE (Degree)	REMARK
5078	43.1	34.98	54	-10.9	34.07	8.03	33.98	100	211	Average
5078	56.9	48.78	74	-17.1	34.07	8.03	33.98	100	211	Peak
5230	97.01	88.61			34.19	8.22	34.01	100	211	Average
5230	105.85	97.45			34.19	8.22	34.01	100	211	Peak
5372	43.21	34.54	54	-10.79	34.29	8.41	34.03	100	211	Average
5372	57.58	48.91	74	-16.42	34.29	8.41	34.03	100	211	Peak

REMARKS:

- Emission Level = Read Level + Antenna Factor + Cable Loss - Preamp Factor
Margin value = Emission level – Limit value
- 5230MHz: Fundamental frequency.



A D T

EUT TEST CONDITION		MEASUREMENT DETAIL	
CHANNEL	Channel 54	FREQUENCY RANGE	1GHz ~ 40GHz
INPUT POWER	120Vac, 60 Hz	DETECTOR FUNCTION	Peak (PK) Average (AV)
ENVIRONMENTAL CONDITIONS	25deg. C, 65%RH	TESTED BY	Karl Lee

ANTENNA POLARITY & TEST DISTANCE: HORIZONTAL AT 3 M										
FREQ. (MHz)	EMISSION LEVEL (dBuV/m)	READ LEVEL (dBuV)	LIMIT (dBuV/m)	MARGIN (dB)	ANTENNA FACTOR (dB/m)	CABLE LOSS (dB)	PREAMP FACTOR (dB)	ANTENNA HEIGHT (cm)	TABLE ANGLE (Degree)	REMARK
5022	42.85	34.82	54	-11.15	34.03	7.97	33.97	199	135	Average
5022	56.8	48.77	74	-17.2	34.03	7.97	33.97	199	135	Peak
5270	90.87	82.38			34.21	8.29	34.01	199	135	Average
5270	98.66	90.17			34.21	8.29	34.01	199	135	Peak
5456	43.52	34.7	54	-10.48	34.36	8.51	34.05	199	135	Average
5456	57.8	48.98	74	-16.2	34.36	8.51	34.05	199	135	Peak
ANTENNA POLARITY & TEST DISTANCE: VERTICAL AT 3 M										
FREQ. (MHz)	EMISSION LEVEL (dBuV/m)	READ LEVEL (dBuV)	LIMIT (dBuV/m)	MARGIN (dB)	ANTENNA FACTOR (dB/m)	CABLE LOSS (dB)	PREAMP FACTOR (dB)	ANTENNA HEIGHT (cm)	TABLE ANGLE (Degree)	REMARK
5146	43	34.75	54	-11	34.12	8.13	34	114	204	Average
5146	57.61	49.36	74	-16.39	34.12	8.13	34	114	204	Peak
5270	98.5	90.01			34.21	8.29	34.01	114	204	Average
5270	106.05	97.56			34.21	8.29	34.01	114	204	Peak
5352	43.16	34.53	54	-10.84	34.28	8.38	34.03	114	204	Average
5352	57.61	48.98	74	-16.39	34.28	8.38	34.03	114	204	Peak

REMARKS:

- Emission Level = Read Level + Antenna Factor + Cable Loss - Preamp Factor
Margin value = Emission level – Limit value
- 5270MHz: Fundamental frequency.



A D T

EUT TEST CONDITION		MEASUREMENT DETAIL	
CHANNEL	Channel 62	FREQUENCY RANGE	1GHz ~ 40GHz
INPUT POWER	120Vac, 60 Hz	DETECTOR FUNCTION	Peak (PK) Average (AV)
ENVIRONMENTAL CONDITIONS	25deg. C, 65%RH	TESTED BY	Karl Lee

ANTENNA POLARITY & TEST DISTANCE: HORIZONTAL AT 3 M										
FREQ. (MHz)	EMISSION LEVEL (dBuV/m)	READ LEVEL (dBuV)	LIMIT (dBuV/m)	MARGIN (dB)	ANTENNA FACTOR (dB/m)	CABLE LOSS (dB)	PREAMP FACTOR (dB)	ANTENNA HEIGHT (cm)	TABLE ANGLE (Degree)	REMARK
5080	42.9	34.78	54	-11.1	34.07	8.03	33.98	216	141	Average
5080	56.8	48.68	74	-17.2	34.07	8.03	33.98	216	141	Peak
5310	89.77	81.22			34.25	8.32	34.02	216	141	Average
5310	97.65	89.1			34.25	8.32	34.02	216	141	Peak
5430	43.62	34.83	54	-10.38	34.35	8.48	34.04	216	141	Average
5430	57.9	49.11	74	-16.1	34.35	8.48	34.04	216	141	Peak

ANTENNA POLARITY & TEST DISTANCE: VERTICAL AT 3 M										
FREQ. (MHz)	EMISSION LEVEL (dBuV/m)	READ LEVEL (dBuV)	LIMIT (dBuV/m)	MARGIN (dB)	ANTENNA FACTOR (dB/m)	CABLE LOSS (dB)	PREAMP FACTOR (dB)	ANTENNA HEIGHT (cm)	TABLE ANGLE (Degree)	REMARK
5118	43.19	34.99	54	-10.81	34.09	8.1	33.99	134	206	Average
5118	56.95	48.75	74	-17.05	34.09	8.1	33.99	134	206	Peak
5310	97.87	89.32			34.25	8.32	34.02	134	206	Average
5310	105.04	96.49			34.25	8.32	34.02	134	206	Peak
5350	46.96	38.33	54	-7.04	34.28	8.38	34.03	134	206	Average
5350	58.74	50.11	74	-15.26	34.28	8.38	34.03	134	206	Peak

REMARKS:

- Emission Level = Read Level + Antenna Factor + Cable Loss - Preamp Factor
Margin value = Emission level – Limit value
- 5310MHz: Fundamental frequency.



A D T

EUT TEST CONDITION		MEASUREMENT DETAIL	
CHANNEL	Channel 102	FREQUENCY RANGE	1GHz ~ 40GHz
INPUT POWER	120Vac, 60 Hz	DETECTOR FUNCTION	Peak (PK) Average (AV)
ENVIRONMENTAL CONDITIONS	25deg. C, 65%RH	TESTED BY	Karl Lee

ANTENNA POLARITY & TEST DISTANCE: HORIZONTAL AT 3 M										
FREQ. (MHz)	EMISSION LEVEL (dBuV/m)	READ LEVEL (dBuV)	LIMIT (dBuV/m)	MARGIN (dB)	ANTENNA FACTOR (dB/m)	CABLE LOSS (dB)	PREAMP FACTOR (dB)	ANTENNA HEIGHT (cm)	TABLE ANGLE (Degree)	REMARK
5410	43.52	34.8	54	-10.48	34.32	8.44	34.04	111	185	Average
5410	57.26	48.54	74	-16.74	34.32	8.44	34.04	111	185	Peak
5470	56.56	47.73	68.2	-11.64	34.37	8.51	34.05	111	185	Peak
5510	88.6	79.69			34.4	8.57	34.06	111	185	Average
5510	96.02	87.11			34.4	8.57	34.06	111	185	Peak
5725	56.76	47.6	68.2	-11.44	34.62	8.65	34.11	111	185	Peak
ANTENNA POLARITY & TEST DISTANCE: VERTICAL AT 3 M										
FREQ. (MHz)	EMISSION LEVEL (dBuV/m)	READ LEVEL (dBuV)	LIMIT (dBuV/m)	MARGIN (dB)	ANTENNA FACTOR (dB/m)	CABLE LOSS (dB)	PREAMP FACTOR (dB)	ANTENNA HEIGHT (cm)	TABLE ANGLE (Degree)	REMARK
5348	43.24	34.61	54	-10.76	34.28	8.38	34.03	108	151	Average
5348	57.5	48.87	74	-16.5	34.28	8.38	34.03	108	151	Peak
5470	59.24	50.41	68.2	-8.96	34.37	8.51	34.05	108	151	Peak
5510	96.35	87.44			34.4	8.57	34.06	108	151	Average
5510	104.08	95.17			34.4	8.57	34.06	108	151	Peak
5725	57.06	47.9	68.2	-11.14	34.62	8.65	34.11	108	151	Peak

REMARKS:

- Emission Level = Read Level + Antenna Factor + Cable Loss - Preamp Factor
Margin value = Emission level – Limit value
- 5510MHz: Fundamental frequency.
- 5470MHz & 5725MHz: Out of restricted band



A D T

EUT TEST CONDITION		MEASUREMENT DETAIL	
CHANNEL	Channel 110	FREQUENCY RANGE	1GHz ~ 40GHz
INPUT POWER	120Vac, 60 Hz	DETECTOR FUNCTION	Peak (PK) Average (AV)
ENVIRONMENTAL CONDITIONS	25deg. C, 65%RH	TESTED BY	Karl Lee

ANTENNA POLARITY & TEST DISTANCE: HORIZONTAL AT 3 M										
FREQ. (MHz)	EMISSION LEVEL (dBuV/m)	READ LEVEL (dBuV)	LIMIT (dBuV/m)	MARGIN (dB)	ANTENNA FACTOR (dB/m)	CABLE LOSS (dB)	PREAMP FACTOR (dB)	ANTENNA HEIGHT (cm)	TABLE ANGLE (Degree)	REMARK
5384	43.1	34.42	54	-10.9	34.31	8.41	34.04	110	185	Average
5384	56.85	48.17	74	-17.15	34.31	8.41	34.04	110	185	Peak
5470	56.39	47.56	68.2	-11.81	34.37	8.51	34.05	110	185	Peak
5550	89.81	80.84			34.45	8.59	34.07	110	185	Average
5550	97.49	88.52			34.45	8.59	34.07	110	185	Peak
5725	55.62	46.46	68.2	-12.58	34.62	8.65	34.11	110	185	Peak

ANTENNA POLARITY & TEST DISTANCE: VERTICAL AT 3 M										
FREQ. (MHz)	EMISSION LEVEL (dBuV/m)	READ LEVEL (dBuV)	LIMIT (dBuV/m)	MARGIN (dB)	ANTENNA FACTOR (dB/m)	CABLE LOSS (dB)	PREAMP FACTOR (dB)	ANTENNA HEIGHT (cm)	TABLE ANGLE (Degree)	REMARK
5450	43.24	34.42	54	-10.76	34.36	8.51	34.05	106	178	Average
5450	57.54	48.72	74	-16.46	34.36	8.51	34.05	106	178	Peak
5470	55.29	46.46	68.2	-12.91	34.37	8.51	34.05	106	178	Peak
5550	97.61	88.64			34.45	8.59	34.07	106	178	Average
5550	105.91	96.94			34.45	8.59	34.07	106	178	Peak
5725	56.21	47.05	68.2	-11.99	34.62	8.65	34.11	106	178	Peak

REMARKS:

- Emission Level = Read Level + Antenna Factor + Cable Loss - Preamp Factor
Margin value = Emission level – Limit value
- 5550MHz: Fundamental frequency.
- 5470MHz & 5725MHz: Out of restricted band



A D T

EUT TEST CONDITION		MEASUREMENT DETAIL	
CHANNEL	Channel 134	FREQUENCY RANGE	1GHz ~ 40GHz
INPUT POWER	120Vac, 60 Hz	DETECTOR FUNCTION	Peak (PK) Average (AV)
ENVIRONMENTAL CONDITIONS	25deg. C, 65%RH	TESTED BY	Karl Lee

ANTENNA POLARITY & TEST DISTANCE: HORIZONTAL AT 3 M										
FREQ. (MHz)	EMISSION LEVEL (dBuV/m)	READ LEVEL (dBuV)	LIMIT (dBuV/m)	MARGIN (dB)	ANTENNA FACTOR (dB/m)	CABLE LOSS (dB)	PREAMP FACTOR (dB)	ANTENNA HEIGHT (cm)	TABLE ANGLE (Degree)	REMARK
5434	43.02	34.23	54	-10.98	34.35	8.48	34.04	107	339	Average
5434	57.93	49.14	74	-16.07	34.35	8.48	34.04	107	339	Peak
5470	57.46	48.63	68.2	-10.74	34.37	8.51	34.05	107	339	Peak
5670	90.73	81.63			34.57	8.63	34.1	107	339	Average
5670	98.58	89.48			34.57	8.63	34.1	107	339	Peak
5725	57.09	47.93	68.2	-11.11	34.62	8.65	34.11	107	339	Peak

ANTENNA POLARITY & TEST DISTANCE: VERTICAL AT 3 M										
FREQ. (MHz)	EMISSION LEVEL (dBuV/m)	READ LEVEL (dBuV)	LIMIT (dBuV/m)	MARGIN (dB)	ANTENNA FACTOR (dB/m)	CABLE LOSS (dB)	PREAMP FACTOR (dB)	ANTENNA HEIGHT (cm)	TABLE ANGLE (Degree)	REMARK
5456	43.18	34.36	54	-10.82	34.36	8.51	34.05	104	169	Average
5456	57.31	48.49	74	-16.69	34.36	8.51	34.05	104	169	Peak
5470	57.44	48.61	68.2	-10.76	34.37	8.51	34.05	104	169	Peak
5670	98.78	89.68			34.57	8.63	34.1	104	169	Average
5670	106.31	97.21			34.57	8.63	34.1	104	169	Peak
5725	57.02	47.86	68.2	-11.18	34.62	8.65	34.11	104	169	Peak

REMARKS:

- Emission Level = Read Level + Antenna Factor + Cable Loss - Preamp Factor
Margin value = Emission level – Limit value
- 5670MHz: Fundamental frequency.
- 5470MHz & 5725MHz: Out of restricted band



A D T

EUT TEST CONDITION		MEASUREMENT DETAIL	
CHANNEL	Channel 151	FREQUENCY RANGE	1GHz ~ 40GHz
INPUT POWER	120Vac, 60 Hz	DETECTOR FUNCTION	Peak (PK) Average (AV)
ENVIRONMENTAL CONDITIONS	25deg. C, 65%RH	TESTED BY	Karl Lee

ANTENNA POLARITY & TEST DISTANCE: HORIZONTAL AT 3 M

FREQ. (MHz)	EMISSION LEVEL (dBuV/m)	READ LEVEL (dBuV)	LIMIT (dBuV/m)	MARGIN (dB)	ANTENNA FACTOR (dB/m)	CABLE LOSS (dB)	PREAMP FACTOR (dB)	ANTENNA HEIGHT (cm)	TABLE ANGLE (Degree)	REMARK
5714	58.49	49.34	68.2	-9.71	34.61	8.65	34.11	196	32	Peak
5724	67.8	58.64	78.2	-10.4	34.62	8.65	34.11	196	32	Peak
5755	96.71	87.5			34.66	8.66	34.11	196	32	Average
5755	104.53	95.32			34.66	8.66	34.11	196	32	Peak
5858	56.5	47.18	78.2	-21.7	34.76	8.7	34.14	196	32	Peak
5866	57.03	47.7	68.2	-11.17	34.76	8.71	34.14	196	32	Peak

ANTENNA POLARITY & TEST DISTANCE: VERTICAL AT 3 M

FREQ. (MHz)	EMISSION LEVEL (dBuV/m)	READ LEVEL (dBuV)	LIMIT (dBuV/m)	MARGIN (dB)	ANTENNA FACTOR (dB/m)	CABLE LOSS (dB)	PREAMP FACTOR (dB)	ANTENNA HEIGHT (cm)	TABLE ANGLE (Degree)	REMARK
5712	58.52	49.37	68.2	-9.68	34.61	8.65	34.11	100	322	Peak
5724	60.38	51.22	78.2	-17.82	34.62	8.65	34.11	100	322	Peak
5755	95.59	86.38			34.66	8.66	34.11	100	322	Average
5755	103.36	94.15			34.66	8.66	34.11	100	322	Peak
5860	57.02	47.7	78.2	-21.18	34.76	8.7	34.14	100	322	Peak
5870	57.64	48.31	68.2	-10.56	34.76	8.71	34.14	100	322	Peak

REMARKS:

- Emission Level = Read Level + Antenna Factor + Cable Loss - Preamp Factor
Margin value = Emission level – Limit value
- 5755MHz: Fundamental frequency.
- 5725MHz & 5825MHz: Out of restricted band



A D T

EUT TEST CONDITION		MEASUREMENT DETAIL	
CHANNEL	Channel 159	FREQUENCY RANGE	1GHz ~ 40GHz
INPUT POWER	120Vac, 60 Hz	DETECTOR FUNCTION	Peak (PK) Average (AV)
ENVIRONMENTAL CONDITIONS	25deg. C, 65%RH	TESTED BY	Karl Lee

ANTENNA POLARITY & TEST DISTANCE: HORIZONTAL AT 3 M

FREQ. (MHz)	EMISSION LEVEL (dBuV/m)	READ LEVEL (dBuV)	LIMIT (dBuV/m)	MARGIN (dB)	ANTENNA FACTOR (dB/m)	CABLE LOSS (dB)	PREAMP FACTOR (dB)	ANTENNA HEIGHT (cm)	TABLE ANGLE (Degree)	REMARK
5710	56.92	47.77	68.2	-11.28	34.61	8.65	34.11	196	32	Peak
5716	56.73	47.58	78.2	-21.47	34.61	8.65	34.11	196	32	Peak
5795	97.22	87.98			34.69	8.68	34.13	196	32	Average
5795	105.3	96.06			34.69	8.68	34.13	196	32	Peak
5852	56.93	47.63	78.2	-21.27	34.74	8.7	34.14	196	32	Peak
5864	57.49	48.16	68.2	-10.71	34.76	8.71	34.14	196	32	Peak

ANTENNA POLARITY & TEST DISTANCE: VERTICAL AT 3 M

FREQ. (MHz)	EMISSION LEVEL (dBuV/m)	READ LEVEL (dBuV)	LIMIT (dBuV/m)	MARGIN (dB)	ANTENNA FACTOR (dB/m)	CABLE LOSS (dB)	PREAMP FACTOR (dB)	ANTENNA HEIGHT (cm)	TABLE ANGLE (Degree)	REMARK
5712	56.34	47.19	68.2	-11.86	34.61	8.65	34.11	160	201	Peak
5720	57.11	47.95	78.2	-21.09	34.62	8.65	34.11	160	201	Peak
5795	96.74	87.5			34.69	8.68	34.13	160	201	Average
5795	104.28	95.04			34.69	8.68	34.13	160	201	Peak
5858	55.95	46.63	78.2	-22.25	34.76	8.7	34.14	160	201	Peak
5868	57.32	47.99	68.2	-10.88	34.76	8.71	34.14	160	201	Peak

REMARKS:

- Emission Level = Read Level + Antenna Factor + Cable Loss - Preamp Factor
Margin value = Emission level – Limit value
- 5795MHz: Fundamental frequency.
- 5725MHz & 5825MHz: Out of restricted band



A D T

BELOW 1GHz WORST-CASE DATA:

802.11n (40MHz)

EUT TEST CONDITION		MEASUREMENT DETAIL	
CHANNEL	Channel 38	FREQUENCY RANGE	30MHz ~ 1GHz
INPUT POWER	120Vac, 60 Hz	DETECTOR FUNCTION	Peak (PK) Quasi-peak (QP)
ENVIRONMENTAL CONDITIONS	25deg. C, 65%RH	TESTED BY	Karl Lee

ANTENNA POLARITY & TEST DISTANCE: HORIZONTAL AT 3 M

FREQ. (MHz)	EMISSION LEVEL (dBuV/m)	READ LEVEL (dBuV)	LIMIT (dBuV/m)	MARGIN (dB)	ANTENNA FACTOR (dB/m)	CABLE LOSS (dB)	PREAMP FACTOR (dB)	ANTENNA HEIGHT (cm)	TABLE ANGLE (Degree)	REMARK
96.15	32.42	53.8	43.5	-11.08	9.38	1.28	32.04	115	165	Peak
161.49	33.31	53.4	43.5	-10.19	10.65	1.52	32.26	106	135	Peak
282.45	24.14	40.47	46	-21.86	13.76	2.03	32.12	102	203	Peak
332.9	23.13	37.4	46	-22.87	15.63	2.19	32.09	122	214	Peak
695.5	24.37	30.21	46	-21.63	23.14	3.11	32.09	132	114	Peak
922.3	28.3	29.89	46	-17.7	26.2	3.53	31.32	192	280	Peak

ANTENNA POLARITY & TEST DISTANCE: VERTICAL AT 3 M

FREQ. (MHz)	EMISSION LEVEL (dBuV/m)	READ LEVEL (dBuV)	LIMIT (dBuV/m)	MARGIN (dB)	ANTENNA FACTOR (dB/m)	CABLE LOSS (dB)	PREAMP FACTOR (dB)	ANTENNA HEIGHT (cm)	TABLE ANGLE (Degree)	REMARK
54.57	36.63	60.63	40	-3.37	7.33	0.9	32.23	154	57	Peak
90.21	32.95	54.61	43.5	-10.55	8.94	1.11	31.71	187	112	Peak
166.35	22.89	43.33	43.5	-20.61	10.29	1.52	32.25	166	335	Peak
678.7	24.67	30.37	46	-21.33	23.36	3.05	32.11	107	87	Peak
877.5	27.01	30.3	46	-18.99	24.84	3.49	31.62	127	1	Peak
944	28.47	29.81	46	-17.53	26.2	3.62	31.16	162	316	Peak

REMARKS: Emission Level = Read Level + Antenna Factor + Cable Loss - Preamp Factor

Margin value = Emission level – Limit value



A D T

802.11n (40MHz)

EUT TEST CONDITION		MEASUREMENT DETAIL	
CHANNEL	Channel 62	FREQUENCY RANGE	30MHz ~ 1GHz
INPUT POWER	120Vac, 60 Hz	DETECTOR FUNCTION	Peak (PK) Quasi-peak (QP)
ENVIRONMENTAL CONDITIONS	25deg. C, 65%RH	TESTED BY	Karl Lee

ANTENNA POLARITY & TEST DISTANCE: HORIZONTAL AT 3 M

FREQ. (MHz)	EMISSION LEVEL (dBuV/m)	READ LEVEL (dBuV)	LIMIT (dBuV/m)	MARGIN (dB)	ANTENNA FACTOR (dB/m)	CABLE LOSS (dB)	PREAMP FACTOR (dB)	ANTENNA HEIGHT (cm)	TABLE ANGLE (Degree)	REMARK
96.42	32.32	53.66	43.5	-11.18	9.42	1.28	32.04	196	42	Peak
162.3	33.2	53.36	43.5	-10.3	10.58	1.52	32.26	105	152	Peak
279.48	24.23	40.58	46	-21.77	13.74	2.03	32.12	127	177	Peak
336.4	22.91	37.01	46	-23.09	15.8	2.19	32.09	136	330	Peak
742.4	25.36	31.07	46	-20.64	23.27	3.16	32.14	174	214	Peak
916.7	28.12	29.99	46	-17.88	25.96	3.53	31.36	191	226	Peak

ANTENNA POLARITY & TEST DISTANCE: VERTICAL AT 3 M

FREQ. (MHz)	EMISSION LEVEL (dBuV/m)	READ LEVEL (dBuV)	LIMIT (dBuV/m)	MARGIN (dB)	ANTENNA FACTOR (dB/m)	CABLE LOSS (dB)	PREAMP FACTOR (dB)	ANTENNA HEIGHT (cm)	TABLE ANGLE (Degree)	REMARK
54.57	35.58	59.58	40	-4.42	7.33	0.9	32.23	154	257	Peak
90.48	33.22	54.88	43.5	-10.28	8.94	1.11	31.71	194	111	Peak
165.81	23.17	43.54	43.5	-20.33	10.36	1.52	32.25	106	152	Peak
687.1	25.01	30.83	46	-20.99	23.23	3.05	32.1	168	317	Peak
793.5	25.63	30.2	46	-20.37	24.23	3.27	32.07	193	241	Peak
952.4	28.55	29.82	46	-17.45	26.12	3.67	31.06	195	226	Peak

REMARKS: Emission Level = Read Level + Antenna Factor + Cable Loss - Preamp Factor
Margin value = Emission level – Limit value



A D T

802.11n (20MHz)

EUT TEST CONDITION		MEASUREMENT DETAIL	
CHANNEL	Channel 140	FREQUENCY RANGE	30MHz ~ 1GHz
INPUT POWER	120Vac, 60 Hz	DETECTOR FUNCTION	Peak (PK) Quasi-peak (QP)
ENVIRONMENTAL CONDITIONS	25deg. C, 65%RH	TESTED BY	Karl Lee

ANTENNA POLARITY & TEST DISTANCE: HORIZONTAL AT 3 M										
FREQ. (MHz)	EMISSION LEVEL (dBuV/m)	READ LEVEL (dBuV)	LIMIT (dBuV/m)	MARGIN (dB)	ANTENNA FACTOR (dB/m)	CABLE LOSS (dB)	PREAMP FACTOR (dB)	ANTENNA HEIGHT (cm)	TABLE ANGLE (Degree)	REMARK
96.69	32.29	53.69	43.5	-11.21	9.42	1.28	32.1	132	296	Peak
164.46	33.07	53.37	43.5	-10.43	10.44	1.52	32.26	104	152	Peak
271.92	25.24	41.79	46	-20.76	13.62	1.94	32.11	136	199	Peak
337.1	23.73	37.82	46	-22.27	15.8	2.19	32.08	133	237	Peak
792.8	26.2	30.77	46	-19.8	24.23	3.27	32.07	124	233	Peak
922.3	28.71	30.3	46	-17.29	26.2	3.53	31.32	192	22	Peak

ANTENNA POLARITY & TEST DISTANCE: VERTICAL AT 3 M										
FREQ. (MHz)	EMISSION LEVEL (dBuV/m)	READ LEVEL (dBuV)	LIMIT (dBuV/m)	MARGIN (dB)	ANTENNA FACTOR (dB/m)	CABLE LOSS (dB)	PREAMP FACTOR (dB)	ANTENNA HEIGHT (cm)	TABLE ANGLE (Degree)	REMARK
54.84	36.59	60.62	40	-3.41	7.3	0.9	32.23	154	84	Peak
90.48	33.08	54.74	43.5	-10.42	8.94	1.11	31.71	194	111	Peak
166.89	23.11	43.62	43.5	-20.39	10.22	1.52	32.25	152	102	Peak
643.7	23.61	30.67	46	-22.39	22.1	2.99	32.15	137	264	Peak
799.8	26.21	30.35	46	-19.79	24.6	3.32	32.06	126	120	Peak
950.3	28.38	29.66	46	-17.62	26.2	3.62	31.1	195	3	Peak

REMARKS: Emission Level = Read Level + Antenna Factor + Cable Loss - Preamp Factor
Margin value = Emission level – Limit value



A D T

802.11n (20MHz)

EUT TEST CONDITION		MEASUREMENT DETAIL	
CHANNEL	Channel 165	FREQUENCY RANGE	30MHz ~ 1GHz
INPUT POWER	120Vac, 60 Hz	DETECTOR FUNCTION	Peak (PK) Quasi-peak (QP)
ENVIRONMENTAL CONDITIONS	25deg. C, 65%RH	TESTED BY	Karl Lee

ANTENNA POLARITY & TEST DISTANCE: HORIZONTAL AT 3 M

FREQ. (MHz)	EMISSION LEVEL (dBuV/m)	READ LEVEL (dBuV)	LIMIT (dBuV/m)	MARGIN (dB)	ANTENNA FACTOR (dB/m)	CABLE LOSS (dB)	PREAMP FACTOR (dB)	ANTENNA HEIGHT (cm)	TABLE ANGLE (Degree)	REMARK
96.69	32.5	53.9	43.5	-11	9.42	1.28	32.1	132	349	Peak
161.76	33.12	53.21	43.5	-10.38	10.65	1.52	32.26	162	17	Peak
281.91	24.11	40.44	46	-21.89	13.76	2.03	32.12	181	291	Peak
331.5	22.72	37.08	46	-23.28	15.54	2.19	32.09	133	15	Peak
736.8	25.09	30.76	46	-20.91	23.3	3.16	32.13	120	54	Peak
941.9	28.86	30.21	46	-17.14	26.2	3.62	31.17	194	191	Peak

ANTENNA POLARITY & TEST DISTANCE: VERTICAL AT 3 M

FREQ. (MHz)	EMISSION LEVEL (dBuV/m)	READ LEVEL (dBuV)	LIMIT (dBuV/m)	MARGIN (dB)	ANTENNA FACTOR (dB/m)	CABLE LOSS (dB)	PREAMP FACTOR (dB)	ANTENNA HEIGHT (cm)	TABLE ANGLE (Degree)	REMARK
54.57	35.62	59.62	40	-4.38	7.33	0.9	32.23	109	273	Peak
90.75	32.95	54.63	43.5	-10.55	8.98	1.11	31.77	148	40	Peak
164.19	23.25	43.55	43.5	-20.25	10.44	1.52	32.26	160	33	Peak
669.6	24.3	30.2	46	-21.7	23.18	3.05	32.13	166	96	Peak
808.2	25.28	29.82	46	-20.72	24.16	3.32	32.02	182	180	Peak
944	28.69	30.03	46	-17.31	26.2	3.62	31.16	162	300	Peak

REMARKS: Emission Level = Read Level + Antenna Factor + Cable Loss - Preamp Factor
Margin value = Emission level – Limit value

4.2 CONDUCTED EMISSION MEASUREMENT

4.2.1 LIMITS OF CONDUCTED EMISSION MEASUREMENT

FREQUENCY OF EMISSION (MHz)	CONDUCTED LIMIT (dB μ V)	
	Quasi-peak	Average
0.15 ~ 0.5	66 to 56	56 to 46
0.5 ~ 5	56	46
5 ~ 30	60	50

NOTE:

1. The lower limit shall apply at the transition frequencies.
2. The limit decreases in line with the logarithm of the frequency in the range of 0.15 to 0.50MHz.
3. All emanations from a class A/B digital device or system, including any network of conductors and apparatus connected thereto, shall not exceed the level of field strengths specified above.

4.2.2 TEST INSTRUMENTS

DESCRIPTION & MANUFACTURER	MODEL NO.	SERIAL NO.	DATE OF CALIBRATION	DUE DATE OF CALIBRATION
Test Receiver ROHDE & SCHWARZ	ESCI	100613	Nov. 11, 2014	Nov. 10, 2015
RF signal cable Woken	5D-FB	Cable-HYC01-01	Dec. 26, 2014	Dec. 25, 2015
LISN ROHDE & SCHWARZ (EUT)	ESH3-Z5	835239/001	Feb. 26, 2015	Feb. 25, 2016
LISN ROHDE & SCHWARZ (Peripheral)	ESH3-Z5	100311	Jul. 21, 2014	Jul. 20, 2015
Software ADT	BV ADT_Cond_ V7.3.7.3	NA	NA	NA

- NOTE:**
1. The calibration interval of the above test instruments is 12 months and the calibrations are traceable to NML/ROC and NIST/USA.
 2. The test was performed in HwaYa Shielded Room 1.
 3. The VCCI Site Registration No. is C-2040.

4.2.3 TEST PROCEDURES

- a. The EUT was placed 0.4 meters from the conducting wall of the shielded room with EUT being connected to the power mains through a line impedance stabilization network (LISN). Other support units were connected to the power mains through another LISN. The two LISNs provide 50 ohm/ 50uH of coupling impedance for the measuring instrument.
- b. Both lines of the power mains connected to the EUT were checked for maximum conducted interference.
- c. The frequency range from 150kHz to 30MHz was searched. Emission levels under (Limit - 20dB) was not recorded.

NOTE: All modes of operation were investigated and the worst-case emissions are reported.

4.2.4 DEVIATION FROM TEST STANDARD

No deviation.

4.2.5 TEST SETUP

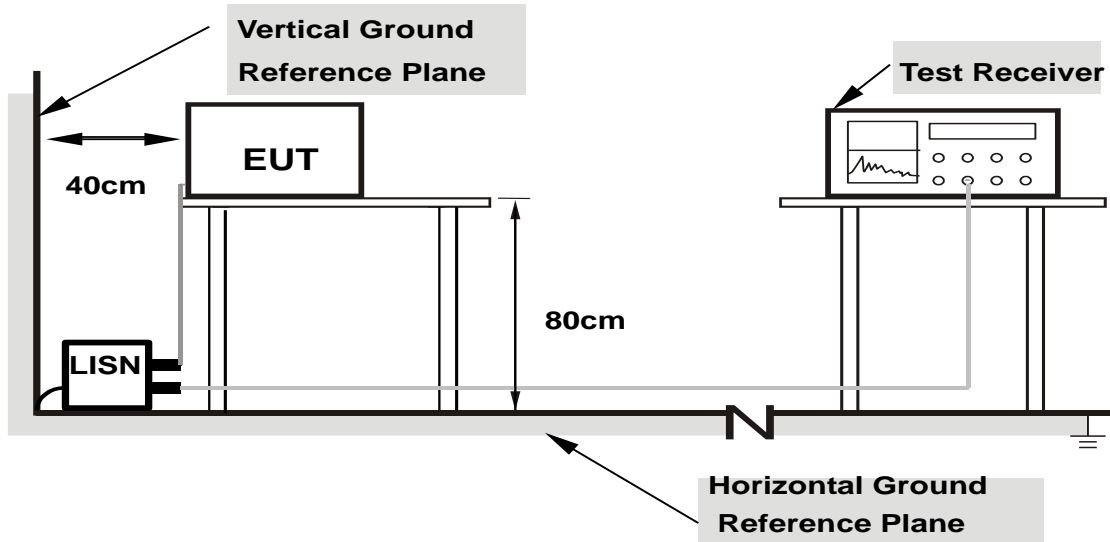

- Note:**
1. Support units were connected to second LISN.
 2. Both of LISNs (AMN) are 80 cm from EUT and at least 80 from other units and other metal planes

For the actual test configuration, please refer to the attached file (Test Setup Photo).

4.2.6 EUT OPERATING CONDITIONS

Same as section 4.1.6.



A D T

4.2.7 TEST RESULTS

CONDUCTED WORST-CASE DATA :

Frequency Range	150kHz ~ 30MHz	Detector Function & Resolution Bandwidth	Quasi-Peak (QP) / Average (AV), 9kHz
Input Power	120Vac, 60Hz	Environmental Conditions	25°C, 65%RH
Tested by	Toby Tian	Test Date	2015/7/31

Phase Of Power : Line (L)										
No	Frequency (MHz)	Correction Factor (dB)	Reading Value (dBuV)		Emission Level (dBuV)		Limit (dBuV)		Margin (dB)	
			Q.P.	AV.	Q.P.	AV.	Q.P.	AV.	Q.P.	AV.
1	0.15000	0.05	46.10	37.84	46.15	37.89	66.00	56.00	-19.85	-18.11
2	0.25810	0.06	39.56	28.80	39.62	28.86	61.49	51.49	-21.87	-22.63
3	0.35000	0.06	41.42	29.25	41.48	29.31	58.96	48.96	-17.48	-19.65
4	2.51395	0.14	35.57	26.17	35.71	26.31	56.00	46.00	-20.29	-19.69
5	5.36200	0.25	46.70	37.72	46.95	37.97	60.00	50.00	-13.05	-12.03
6	21.11400	0.93	41.67	31.28	42.60	32.21	60.00	50.00	-17.40	-17.79

Remarks:

1. Q.P. and AV. are abbreviations of quasi-peak and average individually.
2. The emission levels of other frequencies were very low against the limit.
3. Margin value = Emission level – Limit value
4. Correction factor = Insertion loss + Cable loss
5. Emission Level = Correction Factor + Reading Value

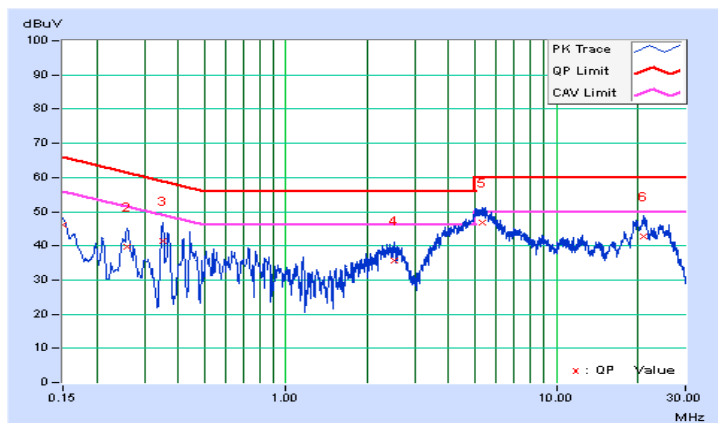



A D T

Frequency Range	150kHz ~ 30MHz	Detector Function & Resolution Bandwidth	Quasi-Peak (QP) / Average (AV), 9kHz
Input Power	120Vac, 60Hz	Environmental Conditions	25°C, 65%RH
Tested by	Toby Tian	Test Date	2015/7/31

Phase Of Power : Neutral (N)										
No	Frequency (MHz)	Correction Factor (dB)	Reading Value (dBuV)		Emission Level (dBuV)		Limit (dBuV)		Margin (dB)	
			Q.P.	AV.	Q.P.	AV.	Q.P.	AV.	Q.P.	AV.
1	0.15000	0.05	46.40	38.21	46.45	38.26	66.00	56.00	-19.55	-17.74
2	0.19800	0.05	37.89	30.53	37.94	30.58	63.69	53.69	-25.75	-23.11
3	0.31118	0.06	36.06	24.14	36.12	24.20	59.94	49.94	-23.82	-25.74
4	0.41799	0.06	37.19	29.83	37.25	29.89	57.49	47.49	-20.24	-17.60
5	2.67400	0.14	32.15	21.48	32.29	21.62	56.00	46.00	-23.71	-24.38
6	5.37400	0.24	41.27	33.56	41.51	33.80	60.00	50.00	-18.49	-16.20

Remarks:

1. Q.P. and AV. are abbreviations of quasi-peak and average individually.
2. The emission levels of other frequencies were very low against the limit.
3. Margin value = Emission level – Limit value
4. Correction factor = Insertion loss + Cable loss
5. Emission Level = Correction Factor + Reading Value

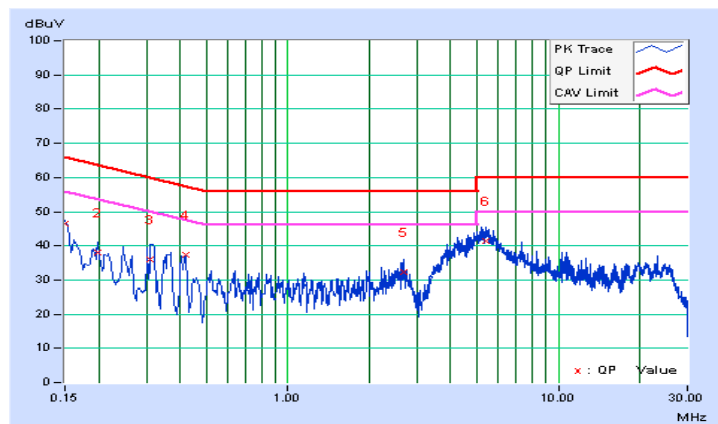

4.3 TRANSMIT POWER MEASUREMENT

4.3.1 LIMITS OF TRANSMIT POWER MEASUREMENT

OPERATION BAND	EUT CATEGORY		LIMIT
U-NII-1		Outdoor Access Point	1 Watt (30 dBm) (Max. e.i.r.p \leq 125mW(21 dBm) at any elevation angle above 30 degrees as measured from the horizon)
		Fixed point-to-point Access Point	1 Watt (30 dBm)
		Indoor Access Point	1 Watt (30 dBm)
	√	Mobile and Portable client device	250mW (24 dBm)
U-NII-2A	√	---	250mW (24 dBm) or 11 dBm+10 log B*
U-NII-2C	√	---	250mW (24 dBm) or 11 dBm+10 log B*
U-NII-3	√	---	1 Watt (30 dBm)

NOTE: Where B is the 26dB emission bandwidth in MHz.

4.3.2 TEST SETUP

FOR POWER OUTPUT MEASUREMENT

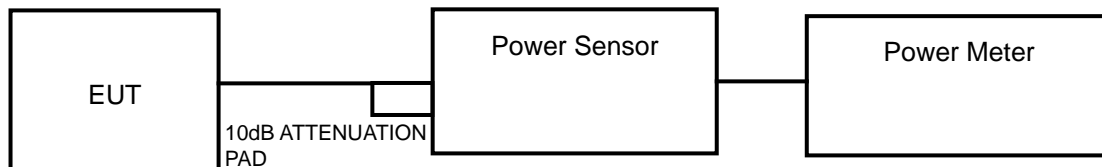

FOR 26dB BANDWIDTH

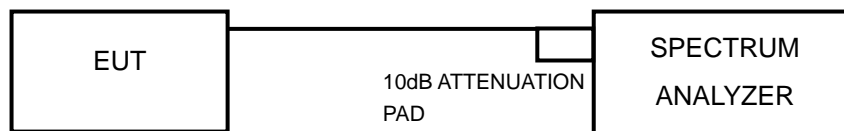

4.3.3 TEST INSTRUMENTS

Refer to section 4.1.3 to get information of above instrument.

4.3.4 TEST PROCEDURE

FOR AVERAGE POWER MEASUREMENT

<802.11a, 802.11n (20MHz), 802.11n (40MHz)>

Method PM is used to perform output power measurement, trigger and gating function of wide band power meter is enabled to measure max output power of TX on burst. Duty factor is not added to measured value.

FOR 26dB BANDWIDTH

- 1) Set RBW = approximately 1% of the emission bandwidth.
- 2) Set the VBW > RBW.
- 3) Detector = Peak.
- 4) Trace mode = max hold.
- 5) Measure the maximum width of the emission that is 26 dB down from the peak of the emission.
Compare this with the RBW setting of the analyzer. Readjust RBW and repeat measurement as needed until the RBW/EBW ratio is approximately 1%.

4.3.5 DEVIATION FROM TEST STANDARD

No deviation.

4.3.6 EUT OPERATING CONDITIONS

The software provided by client to enable the EUT under transmission condition continuously at specific channel frequencies individually.



A D T

4.3.7 TEST RESULTS

POWER OUTPUT

802.11a

CHANNEL	CHANNEL FREQUENCY (MHz)	MAX. CONDUCTED POWER (mW)	MAX. CONDUCTED POWER (dBm)	POWER LIMIT (dBm)	PASS/FAIL
36	5180	12.02	10.80	24	PASS
44	5220	21.68	13.36	24	PASS
48	5240	21.93	13.41	24	PASS
52	5260	19.86	12.98	24	PASS
60	5300	22.03	13.43	24	PASS
64	5320	17.50	12.43	24	PASS
100	5500	13.71	11.37	24	PASS
116	5580	21.53	13.33	24	PASS
140	5700	10.26	10.11	24	PASS
149	5745	10.42	10.18	30	PASS
157	5785	21.18	13.26	30	PASS
165	5825	17.70	12.48	30	PASS

NOTE:

For U-NII-2A, U-NII-2C Band:

1. $11\text{dBm} + 10\log(28.31) = 25.52\text{ dBm} > 24\text{dBm}$.
2. $11\text{dBm} + 10\log(23.92) = 24.79\text{ dBm} > 24\text{dBm}$.
3. $11\text{dBm} + 10\log(23.47) = 24.71\text{ dBm} > 24\text{dBm}$.
4. $11\text{dBm} + 10\log(23.90) = 24.78\text{ dBm} > 24\text{dBm}$.
5. $11\text{dBm} + 10\log(27.50) = 25.39\text{ dBm} > 24\text{dBm}$.
6. $11\text{dBm} + 10\log(22.73) = 24.57\text{ dBm} > 24\text{dBm}$.



A D T

802.11n (20MHz)

CHANNEL	CHANNEL FREQUENCY (MHz)	MAX. CONDUCTED POWER (mW)	MAX. CONDUCTED POWER (dBm)	POWER LIMIT (dBm)	PASS/FAIL
36	5180	10.81	10.34	24	PASS
44	5220	21.68	13.36	24	PASS
48	5240	21.78	13.38	24	PASS
52	5260	22.39	13.50	24	PASS
60	5300	20.94	13.21	24	PASS
64	5320	17.10	12.33	24	PASS
100	5500	12.30	10.90	24	PASS
116	5580	21.63	13.35	24	PASS
140	5700	10.16	10.07	24	PASS
149	5745	10.28	10.12	30	PASS
157	5785	21.18	13.26	30	PASS
165	5825	16.33	12.13	30	PASS

NOTE:

For U-NII-2A, U-NII-2C Band:

1. $11\text{dBm} + 10\log(25.69) = 25.10\text{ dBm} > 24\text{dBm}$.
2. $11\text{dBm} + 10\log(25.62) = 25.09\text{ dBm} > 24\text{dBm}$.
3. $11\text{dBm} + 10\log(23.07) = 24.63\text{ dBm} > 24\text{dBm}$.
4. $11\text{dBm} + 10\log(23.11) = 24.64\text{ dBm} > 24\text{dBm}$.
5. $11\text{dBm} + 10\log(29.08) = 25.64\text{ dBm} > 24\text{dBm}$.
6. $11\text{dBm} + 10\log(23.11) = 24.64\text{ dBm} > 24\text{dBm}$.

**802.11n (40MHz)**

CHANNEL	CHANNEL FREQUENCY (MHz)	MAX. CONDUCTED POWER (mW)	MAX. CONDUCTED POWER (dBm)	POWER LIMIT (dBm)	PASS/FAIL
38	5190	7.96	9.01	24	PASS
46	5230	14.62	11.65	24	PASS
54	5270	15.81	11.99	24	PASS
62	5310	10.23	10.10	24	PASS
102	5510	10.47	10.20	24	PASS
110	5550	14.96	11.75	24	PASS
134	5670	16.03	12.05	24	PASS
151	5755	10.84	10.35	30	PASS
159	5795	14.62	11.65	30	PASS

NOTE:**For U-NII-2A, U-NII-2C Band:**

1. $11\text{dBm} + 10\log(46.00) = 27.63\text{ dBm} > 24\text{dBm}$.
2. $11\text{dBm} + 10\log(45.44) = 27.57\text{ dBm} > 24\text{dBm}$.
3. $11\text{dBm} + 10\log(45.77) = 27.61\text{ dBm} > 24\text{dBm}$.
4. $11\text{dBm} + 10\log(47.18) = 27.74\text{ dBm} > 24\text{dBm}$.
5. $11\text{dBm} + 10\log(52.66) = 28.21\text{ dBm} > 24\text{dBm}$.



A D T

26dB BANDWIDTH

802.11a

CHANNEL	CHANNEL FREQUENCY (MHz)	26dBc BANDWIDTH (MHz)	PASS / FAIL
52	5260	28.31	PASS
60	5300	23.92	PASS
64	5320	23.47	PASS
100	5500	23.90	PASS
116	5580	27.50	PASS
140	5700	22.73	PASS

802.11n (20MHz)

CHANNEL	CHANNEL FREQUENCY (MHz)	26dBc BANDWIDTH (MHz)	PASS / FAIL
52	5260	25.69	PASS
60	5300	25.62	PASS
64	5320	23.07	PASS
100	5500	23.11	PASS
116	5580	29.08	PASS
140	5700	23.11	PASS

802.11n (40MHz)

CHANNEL	CHANNEL FREQUENCY (MHz)	26dBc BANDWIDTH (MHz)	PASS / FAIL
54	5270	46.00	PASS
62	5310	45.44	PASS
102	5510	45.77	PASS
110	5550	47.18	PASS
134	5670	52.66	PASS



A D T

SPECTRUM PLOT OF WORST VALUE

802.11a

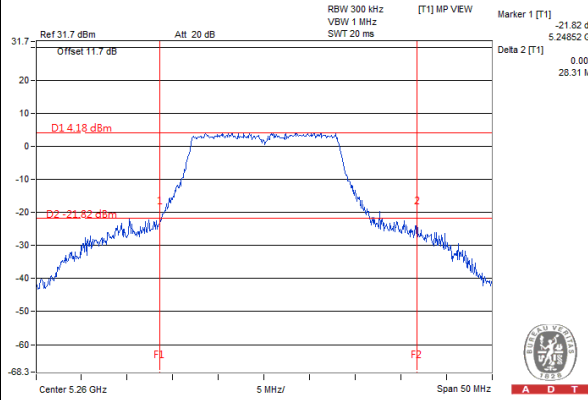

802.11n (20MHz)

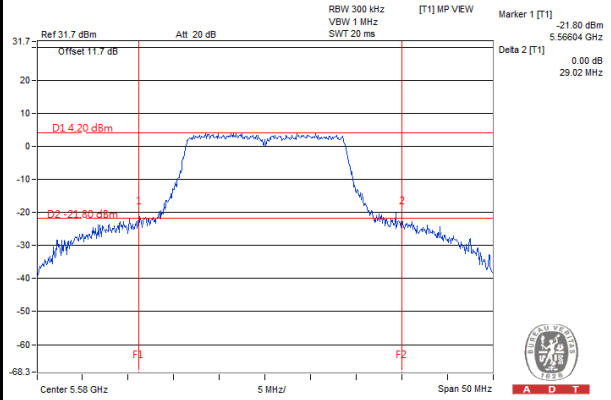

802.11n (40MHz)

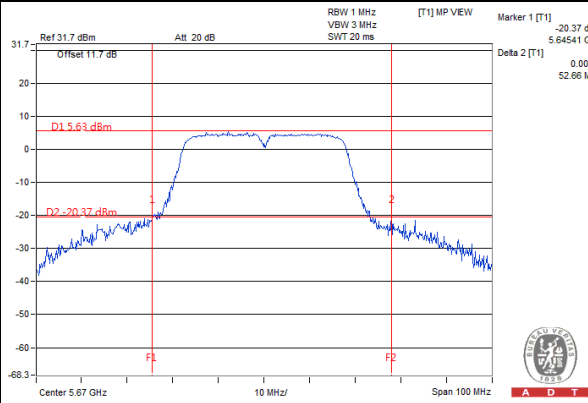

4.4 PEAK POWER SPECTRAL DENSITY MEASUREMENT

4.4.1 LIMITS OF PEAK POWER SPECTRAL DENSITY MEASUREMENT

Operation Band	EUT Category		LIMIT
U-NII-1		Outdoor Access Point	17dBm/ MHz
		Fixed point-to-point Access Point	
		Indoor Access Point	
	√	Mobile and Portable client device	11dBm/ MHz
U-NII-2A	√	---	11dBm/ MHz
U-NII-2C	√	---	11dBm/ MHz
U-NII-3	√	---	30dBm/ 500kHz

4.4.2 TEST SETUP

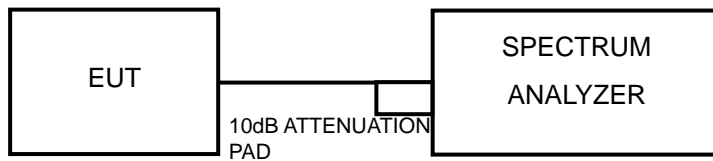

4.4.3 TEST INSTRUMENTS

Refer to section 4.1.3 to get information of above instrument.

4.4.4 TEST PROCEDURES

For U-NII-1, U-NII-2A, U-NII-2C band:

Using method SA-2 alternative

- 1) Set span to encompass the entire emission bandwidth (EBW) of the signal.
- 2) Set RBW = 30 kHz, Set VBW \geq 1 MHz, Detector = RMS
- 3) Set Channel power measure = 1MHz
- 4) Sweep time = 4 second.
- 5) Perform a single sweep.
- 6) Record the max value and add 10 log (1/duty cycle)

For U-NII-3 band:

- 1) Set span to encompass the entire emission bandwidth (EBW) of the signal.
- 2) Set RBW = 500 kHz, Set VBW \geq 3 RBW, Detector = RMS
- 3) Sweep time = auto, trigger set to "free run".
- 4) Trace average at least 100 traces in power averaging mode.
- 5) Record the max value and add 10 log (1/duty cycle)

4.4.5 DEVIATION FROM TEST STANDARD

No deviation.

4.4.6 EUT OPERATING CONDITIONS

Same as Item 4.3.6.



4.4.7 TEST RESULTS

For U-NII-1, U-NII-2A, U-NII-2C Band

802.11a

CHANNEL	FREQUENCY (MHz)	PSD W/O DUTY FACTOR (dBm)	DUTY FACTOR	PSD WITH DUTY FACTOR (dBm)	MAXIMUM LIMIT (dBm)	PASS/FAIL
36	5180	-2.52	1.03	-1.49	11	PASS
44	5220	-0.08	1.03	0.95	11	PASS
48	5240	0.12	1.03	1.15	11	PASS
52	5260	0.40	1.03	1.43	11	PASS
60	5300	0.68	1.03	1.71	11	PASS
64	5320	-0.37	1.03	0.66	11	PASS
100	5500	-0.92	1.03	0.11	11	PASS
116	5580	0.36	1.03	1.39	11	PASS
140	5700	-3.25	1.03	-2.22	11	PASS

NOTE: Refer to section 3.3 for duty cycle spectrum plot.

802.11n (20MHz)

CHANNEL	FREQUENCY (MHz)	PSD W/O DUTY FACTOR (dBm)	DUTY FACTOR	PSD WITH DUTY FACTOR (dBm)	MAXIMUM LIMIT (dBm)	PASS/FAIL
36	5180	-3.56	1.03	-2.53	11	PASS
44	5220	-0.23	1.03	0.80	11	PASS
48	5240	-0.30	1.03	0.73	11	PASS
52	5260	0.00	1.03	1.03	11	PASS
60	5300	0.25	1.03	1.28	11	PASS
64	5320	-0.48	1.03	0.55	11	PASS
100	5500	-1.60	1.03	-0.57	11	PASS
116	5580	0.17	1.03	1.20	11	PASS
140	5700	-3.60	1.03	-2.57	11	PASS

NOTE: Refer to section 3.3 for duty cycle spectrum plot.



A D T

802.11n (40MHz)

CHANNEL	FREQUENCY (MHz)	PSD W/O DUTY FACTOR (dBm)	DUTY FACTOR	PSD WITH DUTY FACTOR (dBm)	MAXIMUM LIMIT (dBm)	PASS/FAIL
38	5190	-8.54	2.04	-6.50	11	PASS
46	5230	-5.34	2.04	-3.30	11	PASS
54	5270	-4.82	2.04	-2.78	11	PASS
62	5310	-6.62	2.04	-4.58	11	PASS
102	5510	-6.05	2.04	-4.01	11	PASS
110	5550	-4.39	2.04	-2.35	11	PASS
134	5670	-5.48	2.04	-3.44	11	PASS

NOTE: Refer to section 3.3 for duty cycle spectrum plot.

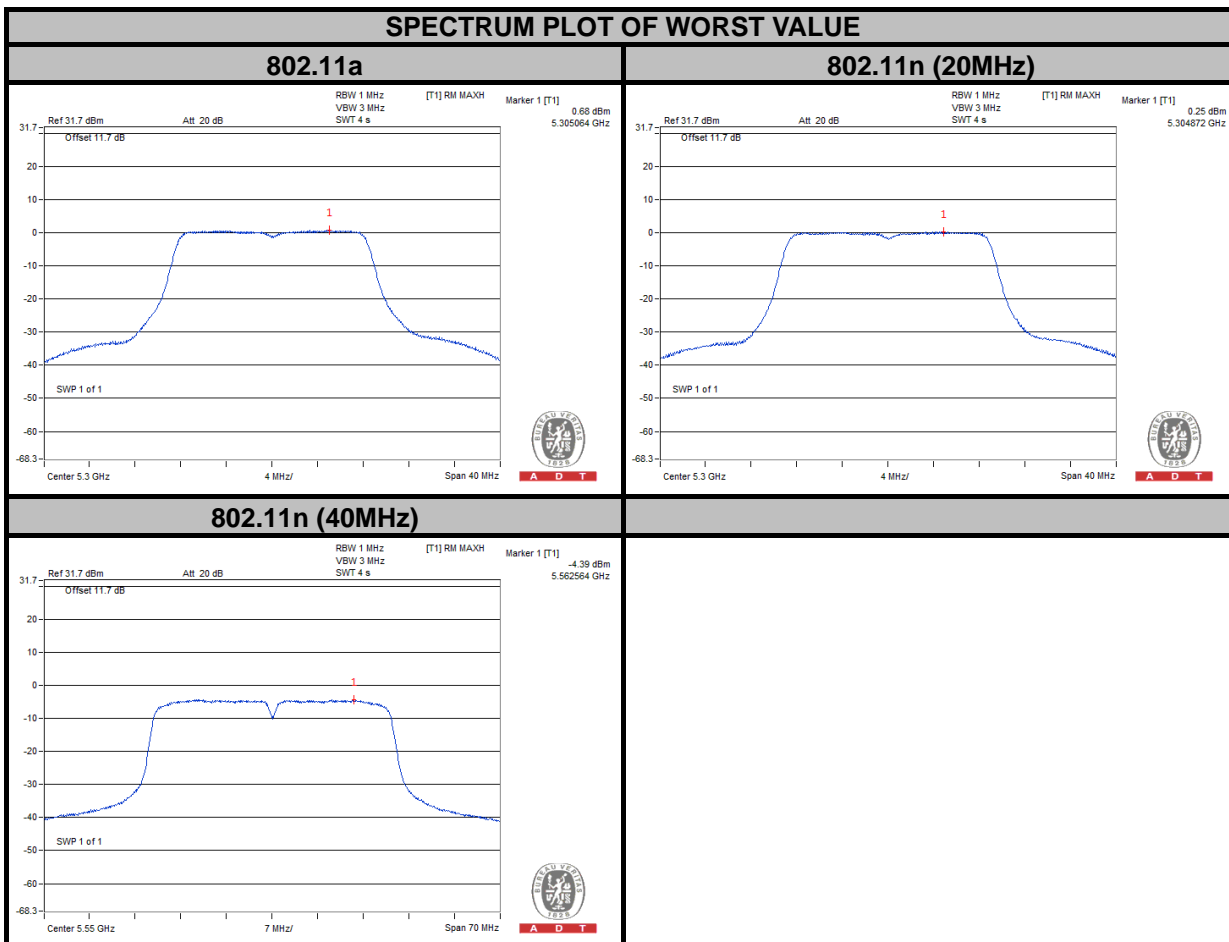



A D T

For U-NII-3 Band

802.11a

CHANNEL	FREQUENCY (MHz)	PSD W/O DUTY FACTOR (dBm)	DUTY FACTOR	PSD WITH DUTY FACTOR (dBm)	LIMIT (dBm/500kHz)	PASS/FAIL
149	5745	-11.67	1.03	-10.64	30	PASS
157	5785	-8.09	1.03	-7.06	30	PASS
165	5825	-5.17	1.03	-4.14	30	PASS

NOTE: Refer to section 3.3 for duty cycle spectrum plot.

802.11n (20MHz)

CHANNEL	FREQUENCY (MHz)	PSD W/O DUTY FACTOR (dBm)	DUTY FACTOR	PSD WITH DUTY FACTOR (dBm)	LIMIT (dBm/500kHz)	PASS/FAIL
149	5745	-11.84	1.03	-10.81	30	PASS
157	5785	-8.92	1.03	-7.89	30	PASS
165	5825	-5.35	1.03	-4.32	30	PASS

NOTE: Refer to section 3.3 for duty cycle spectrum plot.

802.11n (40MHz)

CHANNEL	FREQUENCY (MHz)	PSD W/O DUTY FACTOR (dBm)	DUTY FACTOR	PSD WITH DUTY FACTOR (dBm)	LIMIT (dBm/500kHz)	PASS/FAIL
151	5755	-15.26	2.04	-13.22	30	PASS
159	5795	-14.87	2.04	-12.83	30	PASS

NOTE: Refer to section 3.3 for duty cycle spectrum plot.



A D T

SPECTRUM PLOT OF WORST VALUE

802.11a

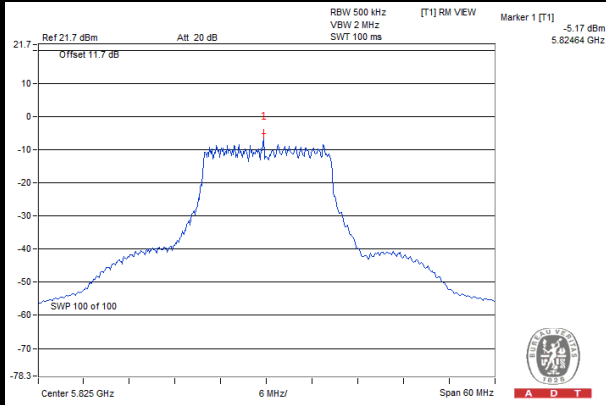

802.11n (20MHz)

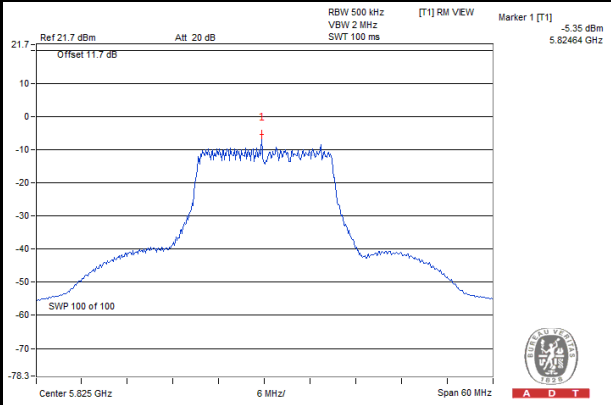

802.11n (40MHz)

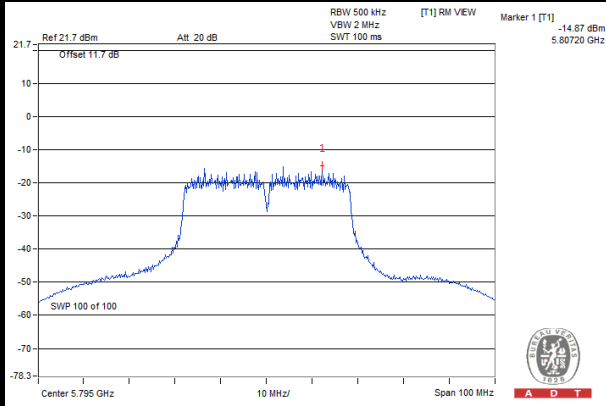

4.5 FREQUENCY STABILITY

4.5.1 LIMITS OF FREQUENCY STABILITY MEASUREMENT

The frequency of the carrier signal shall be maintained within band of operation.

4.5.2 TEST SETUP

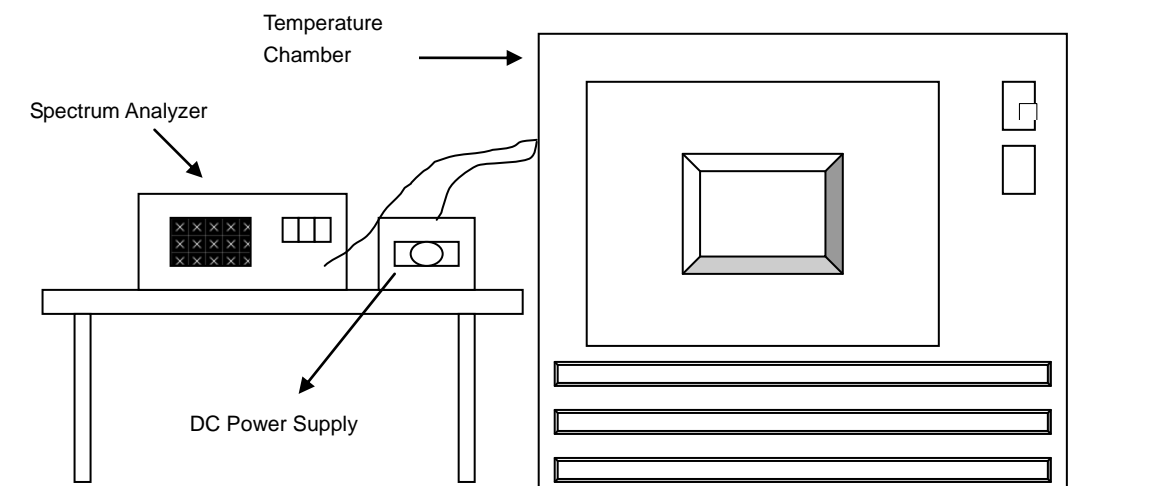

4.5.3 TEST INSTRUMENTS

Refer to section 4.1.3 to get information of above instrument.

4.5.4 TEST PROCEDURE

- a. To ensure emission at the band edge is maintained within the authorized band, those values shall be measured by radiation emissions at upper and lower frequency points, and finally compensated by frequency deviation as procedures below.
- b. The EUT was operated at the maximum output power, and connected to the spectrum analyzer, which is set to maximum hold function and peak detector. The peak value of the power envelope was measured and noted. The upper and lower frequency points were respectively measured relatively 10dB lower than the measured peak value.
- c. The frequency deviation was calculated by adding the upper frequency point and the lower frequency point divided by two. Those detailed values of frequency deviation are provided in table below.

4.5.5 DEVIATION FROM TEST STANDARD

No deviation.

4.5.6 EUT OPERATING CONDITION

Set the EUT transmit at un-modulation mode to test frequency stability.



4.5.7 TEST RESULTS

FREQUENCY STABILITY VERSUS TEMP.									
OPERATING FREQUENCY: 5320MHz									
TEMP. (°C)	POWER SUPPLY (Vdc)	0 MINUTE		2 MINUTE		5 MINUTE		10 MINUTE	
		Measured Frequency (MHz)	Frequency Drift (ppm)	Measured Frequency (MHz)	Frequency Drift (ppm)	Measured Frequency (MHz)	Frequency Drift (ppm)	Measured Frequency (MHz)	Frequency Drift (ppm)
50	3.7	5320.037350	7.021	5320.037320	7.015	5320.037399	7.030	5320.037456	7.041
40	3.7	5320.036810	6.919	5320.036674	6.894	5320.037094	6.973	5320.036589	6.878
30	3.7	5320.038727	7.280	5320.038537	7.244	5320.038850	7.303	5320.038721	7.278
20	3.7	5320.038966	7.324	5320.039399	7.406	5320.039122	7.354	5320.039502	7.425
10	3.7	5320.040478	7.609	5320.040418	7.597	5320.040583	7.628	5320.040688	7.648
0	3.7	5320.038875	7.307	5320.039325	7.392	5320.039299	7.387	5320.039109	7.351
-10	3.7	5320.038402	7.218	5320.038027	7.148	5320.038106	7.163	5320.037954	7.134
-20	3.7	5320.037367	7.024	5320.037304	7.012	5320.037263	7.004	5320.037481	7.045
-30	3.7	5320.035913	6.751	5320.035856	6.740	5320.035487	6.670	5320.036195	6.804

FREQUENCY STABILITY VERSUS VOLTAGE									
OPERATING FREQUENCY: 5320MHz									
TEMP. (°C)	POWER SUPPLY (Vdc)	0 MINUTE		2 MINUTE		5 MINUTE		10 MINUTE	
		Measured Frequency (MHz)	Frequency Drift (ppm)	Measured Frequency (MHz)	Frequency Drift (ppm)	Measured Frequency (MHz)	Frequency Drift (ppm)	Measured Frequency (MHz)	Frequency Drift (ppm)
20	3.3	5320.039176	7.364	5320.039054	7.341	5320.039051	7.340	5320.039108	7.351
	3.7	5320.038966	7.324	5320.039399	7.406	5320.039122	7.354	5320.039502	7.425
	4.20	5320.040109	7.539	5320.040513	7.615	5320.040665	7.644	5320.040367	7.588

4.6 6dB BANDWIDTH MEASUREMENT

4.6.1 LIMITS OF 6dB BANDWIDTH MEASUREMENT

The minimum of 6dB Bandwidth Measurement is 0.5MHz.

4.6.2 TEST SETUP

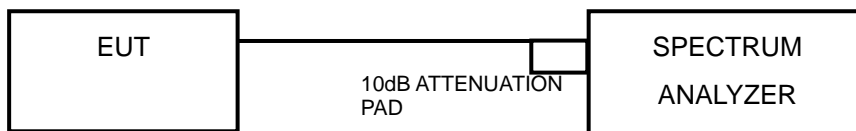

4.6.3 TEST INSTRUMENTS

Refer to section 4.1.3 to get information of above instrument.

4.6.4 TEST PROCEDURE

- Set resolution bandwidth (RBW) = 100kHz
- Set the video bandwidth (VBW) $\geq 3 \times$ RBW, Detector = Peak.
- Trace mode = max hold.
- Sweep = auto couple.
- Measure the maximum width of the emission that is constrained by the frequencies associated with the two amplitude points (upper and lower) that are attenuated by 6 dB relative to the maximum level measured in the fundamental emission.

4.6.5 DEVIATION FROM TEST STANDARD

No deviation.

4.6.6 EUT OPERATING CONDITIONS

The software provided by client to enable the EUT under transmission condition continuously at lowest, middle and highest channel frequencies individually.



A D T

4.6.7 TEST RESULTS

802.11a

CHANNEL	FREQUENCY (MHz)	6dB BANDWIDTH (MHz)	MINIMUM LIMIT (MHz)	PASS / FAIL
149	5745	16.41	0.5	PASS
157	5785	16.42	0.5	PASS
165	5825	16.41	0.5	PASS

802.11n (20MHz)

CHANNEL	FREQUENCY (MHz)	6dB BANDWIDTH (MHz)	MINIMUM LIMIT (MHz)	PASS / FAIL
149	5745	17.65	0.5	PASS
157	5785	17.64	0.5	PASS
165	5825	17.62	0.5	PASS

802.11n (40MHz)

CHANNEL	FREQUENCY (MHz)	6dB BANDWIDTH (MHz)	MINIMUM LIMIT (MHz)	PASS / FAIL
151	5755	35.28	0.5	PASS
159	5795	35.40	0.5	PASS



A D T

SPECTRUM PLOT OF WORST VALUE

802.11a

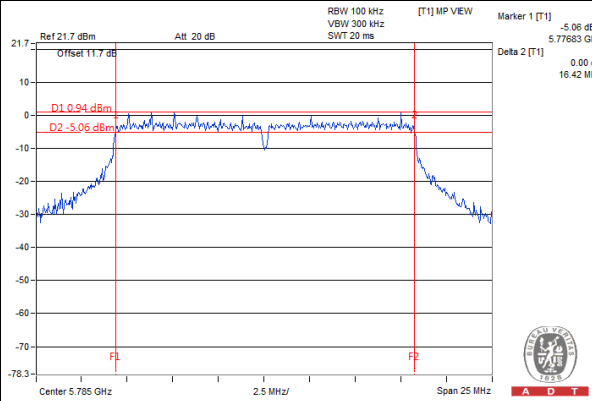

802.11n (20MHz)

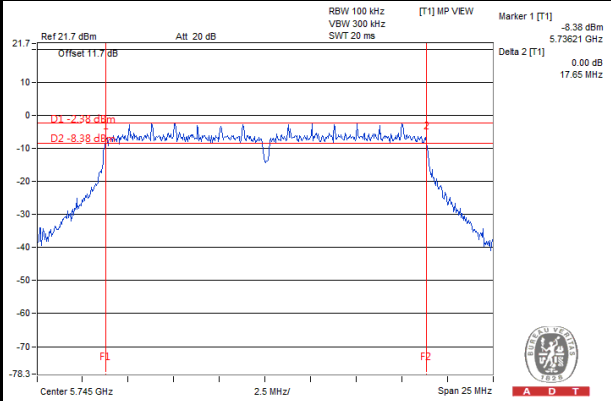

802.11n (40MHz)

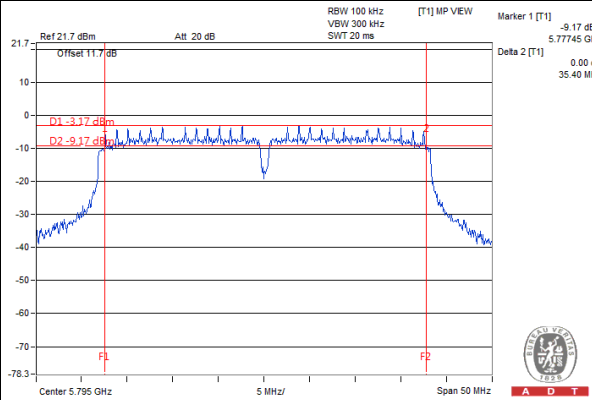



A D T

5. PHOTOGRAPHS OF THE TEST CONFIGURATION

Please refer to the attached file (Test Setup Photo).



A D T

6. INFORMATION ON THE TESTING LABORATORIES

We, Bureau Veritas Consumer Products Services (H.K.) Ltd., Taoyuan Branch, were founded in 1988 to provide our best service in EMC, Radio, Telecom and Safety consultation. Our laboratories are accredited and approved according to ISO/IEC 17025.

If you have any comments, please feel free to contact us at the following:

Linko EMC/RF Lab:

Tel: 886-2-26052180

Fax: 886-2-26051924

Hsin Chu EMC/RF/Telecom Lab:

Tel: 886-3-5935343

Fax: 886-3-5935342

Hwa Ya EMC/RF/Safety Lab:

Tel: 886-3-3183232

Fax: 886-3-3270892

Email: service.adt@tw.bureauveritas.com

Web Site: www.bureauveritas-adt.com

The address and road map of all our labs can be found in our web site also.



A D T

7. APPENDIX A - MODIFICATIONS RECORDERS FOR ENGINEERING CHANGES TO THE EUT BY THE LAB

No any modifications are made to the EUT by the lab during the test.

---END---