



**RADIATED SPURIOUS EMISSIONS PORTIONS OF  
FCC CFR47 PART 90 SUBPART S  
CERTIFICATION TEST REPORT  
FOR**

**TRI BAND 1xRTT CDMA PHONE WITH  
BLUETOOTH**

**MODEL NUMBER: E4233**

**FCC ID: V65E4233**

**REPORT NUMBER: 11U14121-4, Revision A**

**ISSUE DATE: JANUARY 3, 2012**

*Prepared for*

**KYOCERA COMMUNICATIONS, INC.  
9520 TOWNE CENTER DRIVE  
SAN DIEGO, CA 92121, USA**

*Prepared by*

**COMPLIANCE CERTIFICATION SERVICES (UL CCS)  
47173 BENICIA STREET  
FREMONT, CA 94538, U.S.A.  
TEL: (510) 771-1000  
FAX: (510) 661-0888**



**NVLAP LAB CODE 200065-0**

---

Revision History

<u>Rev.</u>	<u>Issue Date</u>	<u>Revisions</u>	<u>Revised By</u>
---	11/11/11	Initial Issue	T. Chan
A	01/03/12	Revised EUT description to remove all instances of: Military Specs	A. Zaffar



# 1. ATTESTATION OF TEST RESULTS

**COMPANY NAME:** KYOCERA COMMUNICATIONS, INC.  
9520 TOWNE CENTER DRIVE  
SAN DIEGO, CA 92121, USA

**EUT DESCRIPTION:** TRI BAND 1XR TT CDMA PHONE WITH BLUETOOTH

**MODEL:** E4233

**SERIAL NUMBER:** 268435457816724579

**DATE TESTED:** OCTOBER 28 AND NOVEMBER 3, 2011

APPLICABLE STANDARDS	
STANDARD	TEST RESULTS
FCC PART 90 Subpart S	PASS (Radiated Portion)

Compliance Certification Services, Inc. (UL CCS) tested the above equipment in accordance with the requirements set forth in the above standards. All indications of Pass/Fail in this report are opinions expressed by UL CCS based on interpretations and/or observations of test results. Measurement Uncertainties were not taken into account and are published for informational purposes only. The test results show that the equipment tested is capable of demonstrating compliance with the requirements as documented in this report.

**Note:** The results documented in this report apply only to the tested sample, under the conditions and modes of operation as described herein. This document may not be altered or revised in any way unless done so by UL CCS and all revisions are duly noted in the revisions section. Any alteration of this document not carried out by UL CCS will constitute fraud and shall nullify the document. No part of this report may be used to claim product certification, approval, or endorsement by NVLAP, NIST, or any government agency.

Approved & Released For UL CCS By:

Tested By:

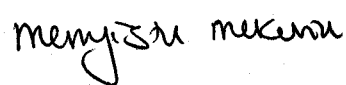

---

THU CHAN  
ENGINEERING MANAGER  
UL CCS

---

MENGISTU MEKURIA  
EMC ENGINEER  
UL CCS

## 2. TEST METHODOLOGY

The tests documented in this report were performed in accordance with TIA-603-C, FCC CFR 47 Part 2, and FCC CFR 47 Part 90 Subpart S.

## 3. FACILITIES AND ACCREDITATION

The test sites and measurement facilities used to collect data are located at 47173 Benicia Street, Fremont, California, USA.

UL CCS is accredited by NVLAP, Laboratory Code 200065-0. The full scope of accreditation can be viewed at <http://www.ccsemc.com>.

## 4. CALIBRATION AND UNCERTAINTY

### 4.1. MEASURING INSTRUMENT CALIBRATION

The measuring equipment utilized to perform the tests documented in this report has been calibrated in accordance with the manufacturer's recommendations, and is traceable to recognized national standards.

### 4.2. SAMPLE CALCULATION

Where relevant, the following sample calculation is provided:

$$\text{Field Strength (dBuV/m)} = \text{Measured Voltage (dBuV)} + \text{Antenna Factor (dB/m)} + \text{Cable Loss (dB)} - \text{Preamp Gain (dB)}$$

$$36.5 \text{ dBuV} + 18.7 \text{ dB/m} + 0.6 \text{ dB} - 26.9 \text{ dB} = 28.9 \text{ dBuV/m}$$

### 4.3. MEASUREMENT UNCERTAINTY

Where relevant, the following measurement uncertainty levels have been estimated for tests performed on the apparatus:

PARAMETER	UNCERTAINTY
Conducted Disturbance, 0.15 to 30 MHz	3.52 dB
Radiated Disturbance, 30 to 1000 MHz	4.94 dB

Uncertainty figures are valid to a confidence level of 95%.

## 5. EQUIPMENT UNDER TEST

### 5.1. DESCRIPTION OF EUT

The EUT is Bluetooth and Tri-band CDMA Phone that manufactured by Kyocera Corporations.

### 5.2. MAXIMUM OUTPUT POWER

The transmitter has a maximum peak ERP output powers as follows:

824 to 849 MHz Authorized Band

Frequency Range (MHz)	Modulation	ERP Peak Power (dBm)	ERP Peak Power (mW)
Low CH - 817.90	CDMA2000	32.01	1588.5
Mid CH - 820.50		32.16	1644.4
High CH - 823.10		31.95	1566.8

### 5.3. SOFTWARE AND FIRMWARE

The EUT is linked with Agilent Communication Test Set.

### 5.4. WORST-CASE CONFIGURATION AND MODE

The worst-position was the EUT with highest emissions. To determine the worst-case, the EUT was investigated on X, Y, and Z Positions, and the worst position among X, Y, and Z with an AC Adapter and headset. After the investigations the worst-cases were turned out to be Z position with headset only.

---

**PROCEDURE USED TO ESTABLISH TEST SIGNAL**

**3G-CDMA2000 1xRTT**

This procedure assumes the Agilent 8960 Test Set has the following applications installed and with valid license.

<u>Application</u>	<u>Rev, License</u>
CDMA2000 Mobil Test	B.10.11, L

1xRTT

- Call Setup > Shift & Preset
- Protocol Rev > 6 (IS-2000-0)
- Radio Config (RC) > RC3 (Fwd3, Rvs3)
- FCH Service Option (SO) Setup > 55
- Traffic Data Rate > Full
- TDSO SCH Info > F-SCH Parameters > F-SCH Data Rate > 153.6 kbps  
> R-SCH Parameters > R-SCH Data Rate > 153.6 kbps
- Cell Info > Cell Parameters > System ID (SID) > 2  
> Network ID (NID) > 65535

Once "Active Cell" show "Connected" then change "Rvs Power Ctrl" from "Active bits" to "**All Up bits**" to get the maximum power.

Worst-case Measurement Result @ Low, Middle and High Channel

Worst-case Measurement Result for Low, Middle and High Channel under Radio Configuration RC3 and Service Option 55.

## 5.5. DESCRIPTION OF TEST SETUP

### SUPPORT EQUIPMENT

PERIPHERAL SUPPORT EQUIPMENT LIST				
Description	Manufacturer	Model	Serial Number	FCC ID
AC Adapter (EUT)	Kyocera	SCP-31ADT	02041	DoC
Headset	Kyocera	N/A	02051	DoC

### I/O CABLES

I/O CABLE LIST						
Cable No.	Port	# of Identical Ports	Connector Type	Cable Type	Cable Length	Remarks
1	DC Input	1	Micro-USB	Un-Shielded	1.5 m	NA
2	Audio	1	3.5 mm Audio Jack	Un-Shielded	1 m	NA

### TEST SETUP

The EUT is a CDMA phone and is tested as a standalone configuration. Communications Test Set is used to link the device under test.



**SETUP DIAGRAM FOR TESTS**

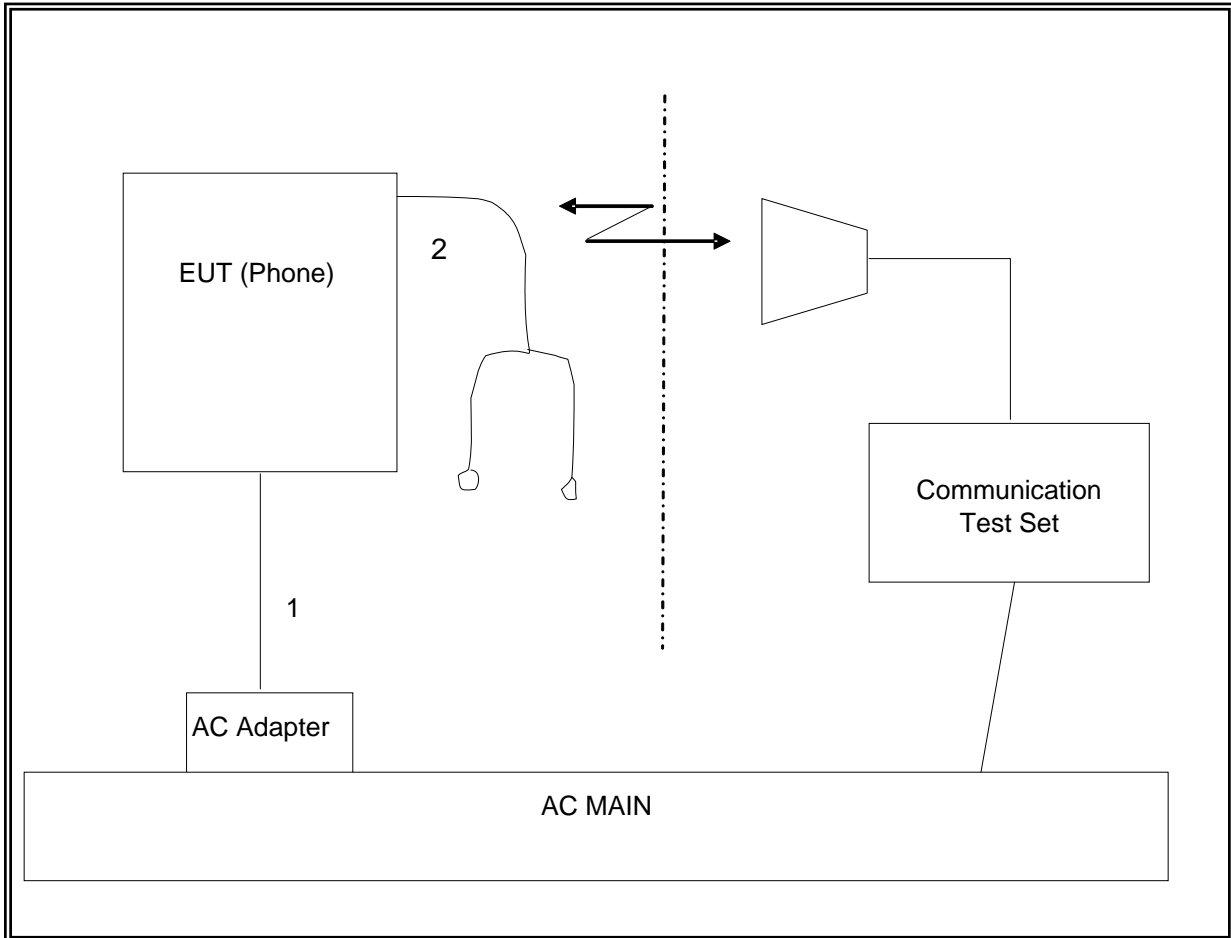

## 6. TEST AND MEASUREMENT EQUIPMENT

The following test and measurement equipment was utilized for the tests documented in this report:

TEST EQUIPMENT LIST				
Description	Manufacturer	Model	Asset	Cal Due
Spectrum Analyzer, 26.5 GHz	Agilent / HP	E4440A	C01179	01/19/12
Communications Test Set	Agilent / HP	E5515C	C01086	07/17/12
Antenna, Horn, 18 GHz	EMCO	3115	C00943	CNR
Antenna, Horn, 18 GHz	EMCO	3115	C00945	10/6/2012
Antenna, Bilog, 2 GHz	Sunol Sciences	JB1	C01011	07/16/12
Preamplifier, 26.5 GHz	Agilent / HP	8449B	C01052	07/12/12
Dipole	Speag	D900V2	N/A	11/16/11
Highpass Filter, 1.5 GHz	Micro-Tronics	HPM13193	N02689	CNR
Vector signal generator, 6 GHz	Agilent / HP	E4438C		06/09/12

## 7. LIMITS AND RESULTS

### 7.1. RADIATED OUTPUT POWER

#### LIMITS

§ 90.635 Limitations on power and antenna height.

(a) The effective radiated power and antenna height for base stations may not exceed 1 kilowatt (30 dBw) and 304 m. (1,000 ft.) above average terrain (AAT), respectively, or the equivalent thereof as determined from the Table. These are maximum values, and applicants will be required to justify power levels and antenna heights requested.

(b) The maximum output power of the transmitter for mobile stations is 100 watts (20 dBw).

Table—Equivalent Power and Antenna Heights for Base Stations in the 851–869 MHz and 935–940 MHz Bands Which Have a Requirement for a 32 km (20 mi) Service Area Radius

Antenna height (ATT) meters (feet)	Effective radiated power (watts) <sup>1,2,4</sup>
Above 1,372 (4,500)	65
Above 1,220 (4,000) to 1,372 (4,500)	70
Above 1,067 (3,500) to 1,220 (4,000)	75
Above 915 (3,000) to 1,067 (3,500)	100
Above 763 (2,500) to 915 (3,000)	140
Above 610 (2,000) to 763 (2,500)	200
Above 458 (1,500) to 610 (2,000)	350
Above 305 (1,000) to 458 (1,500)	600
Up to 305 (1,000)	<sup>3</sup> 1,000

<sup>1</sup>Power is given in terms of effective radiated power (ERP).

<sup>2</sup>Applicants in the Los Angeles, CA, area who demonstrate a need to serve both the downtown and fringe areas will be permitted to utilize an ERP of 1 kw at the following mountaintop sites: Santiago Park, Sierra Peak, Mount Lukens, and Mount Wilson.

3Stations with antennas below 305 m (1,000 ft) (AAT) will be restricted to a maximum power of 1 kw (ERP).

**CELL OUTPUT POWER (ERP)**

High Frequency Substitution Measurement Compliance Certification Services Chamber A								
<b>Company:</b>		KYOCERA						
<b>Project #:</b>		11U14121						
<b>Date:</b>		10/28/11						
<b>Test Engineer:</b>		MENGISTU MEKURIA						
<b>Configuration:</b>		EUT ALONE						
<b>Mode:</b>		TX, CELL BAND CDMA MODE, BC10						
<b><u>Test Equipment:</u></b>								
Receiving: Sunol T122, and Chamber A N-type Cable								
Substitution: Dipole S/N: 00022117, 4ft SMA Cable (SN # 245182002) Warehouse.								
f MHz	SG reading (dBm)	Ant. Pol. (H/V)	Cable Loss (dB)	Antenna Gain (dBd)	ERP (dBm)	Limit (dBm)	Margin (dB)	Notes
817.90	32.51	V	0.5	0.0	32.01	50.0	-18.0	
817.90	19.88	H	0.5	0.0	19.38	50.0	-30.6	
820.50	32.66	V	0.5	0.0	32.16	50.0	-17.8	
820.50	20.24	H	0.5	0.0	19.74	50.0	-30.3	
823.10	32.45	V	0.5	0.0	31.95	50.0	-18.0	
823.10	20.48	H	0.5	0.0	19.98	50.0	-30.0	
Rev. 3.17.11								

## 7.2. FIELD STRENGTH OF SPURIOUS RADIATION

### LIMIT

§ 90.691 Emission mask requirements for EA-based systems.

(a) Out-of-band emission requirement shall apply only to the “outer” channels included in an EA license and to spectrum adjacent to interior channels used by incumbent licensees. The emission limits are as follows:

(1) For any frequency removed from the EA licensee's frequency block by up to and including 37.5 kHz, the power of any emission shall be attenuated below the transmitter power (P) in watts by at least  $116 \text{ Log}_{10}(f/6.1)$  decibels or  $50 + 10 \text{ Log}_{10}(P)$  decibels or 80 decibels, whichever is the lesser attenuation, where f is the frequency removed from the center of the outer channel in the block in kilohertz and where f is greater than 12.5 kHz.

(2) For any frequency removed from the EA licensee's frequency block greater than 37.5 kHz, the power of any emission shall be attenuated below the transmitter power (P) in watts by at least  $43 + 10 \text{ Log}_{10}(P)$  decibels or 80 decibels, whichever is the lesser attenuation, where f is the frequency removed from the center of the outer channel in the block in kilohertz and where f is greater than 37.5 kHz.

(b) When an emission outside of the authorized bandwidth causes harmful interference, the Commission may, at its discretion, require greater attenuation than specified in this section.

**CELL SPURIOUS & HARMONIC (ERP)**

**Compliance Certification Services**  
**Above 1GHz High Frequency Substitution Measurement**

**Company:** KYOCERA  
**Project #:** 11U14121  
**Date:** 11/03/11  
**Test Engineer:** MENGISTU MEKURIA  
**Configuration:** EUT WITH HEADSET AND AC ADAPTER  
**Mode:** TX, CELL BAND CDMA MODE, BC10

**Chamber**

5m Chamber A

**Pre-amplifier**

T144 8449B

**Filter**

Filter 1

**Limit**

Part 90

f GHz	SG reading (dBm)	Ant. Pol. (H/V)	Distance (m)	Preamp (dB)	Filter (dB)	EIRP (dBm)	Limit (dBm)	Delta (dB)	Notes
<b>Low Ch, 817.90MHz</b>									
1.636	-4.0	V	3.0	38.2	1.0	-41.2	-13.0	-28.2	
2.454	-17.9	V	3.0	37.5	1.0	-54.4	-13.0	-41.4	
3.272	-19.2	V	3.0	37.1	1.0	-55.4	-13.0	-42.4	
3.453	-15.1	V	3.0	37.0	1.0	-51.1	-13.0	-38.1	
1.636	-0.8	H	3.0	38.2	1.0	-38.0	-13.0	-25.0	
2.454	-20.0	H	3.0	37.5	1.0	-56.5	-13.0	-43.5	
3.272	-18.3	H	3.0	37.1	1.0	-54.4	-13.0	-41.4	
3.453	-13.5	H	3.0	37.0	1.0	-49.5	-13.0	-36.5	
<b>Mid Ch, 820.50MHz</b>									
1.641	-5.0	V	3.0	38.2	1.0	-42.1	-13.0	-29.1	
2.462	-18.9	V	3.0	37.5	1.0	-55.4	-13.0	-42.4	
3.282	-19.2	V	3.0	37.1	1.0	-55.3	-13.0	-42.3	
3.462	-14.7	V	3.0	37.0	1.0	-50.7	-13.0	-37.7	
1.641	0.8	H	3.0	38.2	1.0	-36.3	-13.0	-23.3	
2.462	-19.6	H	3.0	37.5	1.0	-56.1	-13.0	-43.1	
3.282	-16.6	H	3.0	37.1	1.0	-52.8	-13.0	-39.8	
3.462	-13.4	H	3.0	37.0	1.0	-49.4	-13.0	-36.4	
<b>High Ch, 823.10MHz</b>									
1.646	-3.6	V	3.0	38.2	1.0	-40.8	-13.0	-27.8	
2.469	-19.8	V	3.0	37.5	1.0	-56.2	-13.0	-43.2	
3.292	-19.0	V	3.0	37.1	1.0	-55.1	-13.0	-42.1	
3.471	-15.9	V	3.0	37.0	1.0	-51.9	-13.0	-38.9	
1.646	1.1	H	3.0	38.2	1.0	-36.1	-13.0	-23.1	
2.469	-19.6	H	3.0	37.5	1.0	-56.0	-13.0	-43.0	
3.292	-17.4	H	3.0	37.1	1.0	-53.5	-13.0	-40.5	
3.471	-14.0	H	3.0	37.0	1.0	-50.0	-13.0	-37.0	

Rev. 03.03.09  
 Note: No other emissions were detected above the system noise floor.