

Applicant:	Kyocera
FCC ID:	V65E4100
Report #:	CT-E4100_20RF-0810-R1

Hearing Aid Compatibility (HAC)  
RF Emissions

FCC 47 CFR Part 20.19

Test Report

For

Kyocera Corporation  
c/o Kyocera Communications, Inc.

Product:	Dual-Band CDMA Phone
Model:	E4100

**TABLE OF CONTENTS**

<b>1</b>	<b>SUMMARY OF TESTING.....</b>	<b>4</b>
<b>2</b>	<b>EQUIPMENT UNDER TEST INFORMATION .....</b>	<b>4</b>
<b>3</b>	<b>TEST CONDITIONS .....</b>	<b>5</b>
3.1	AMBIENT CONDITIONS.....	5
3.2	RF CHARACTERISTICS OF THE TEST SITE .....	5
3.3	TEST SIGNAL, FREQUENCIES AND OUTPUT POWER.....	5
3.4	EUT OPERATING CONDITIONS .....	6
<b>4</b>	<b>DESCRIPTION OF TEST EQUIPMENT.....</b>	<b>7</b>
4.1	TEST EQUIPMENT USED.....	7
4.2	NEAR FIELD MEASUREMENT SYSTEM .....	7
4.3	ISOTROPIC E-FIELD PROBE .....	8
4.4	ISOTROPIC -FIELD PROBE .....	8
<b>5</b>	<b>SYSTEM VALIDATION .....</b>	<b>9</b>
5.1	DIPOLE VALIDATION SETUP.....	9
5.2	DIPOLE VALIDATION RESULTS .....	10
<b>6</b>	<b>DESCRIPTION OF TEST PROCEDURE .....</b>	<b>11</b>
6.1	TEST POSITIONS.....	11
6.2	RF EMISSION MEASUREMENTS REFERENCE AND PLANE .....	11
6.3	RF EMISSIONS MEASUREMENT PROCEDURES .....	12
<b>7</b>	<b>PROBE MODULATION FACTOR (PMF).....</b>	<b>13</b>
7.1	PMF MEASUREMENT PROCEDURES .....	13
7.2	PMF TEST RESULTS.....	14
7.3	PMF PEAK POWER MEASUREMENT PLOTS.....	15
<b>8</b>	<b>EMISSION DATA EXTRACTION AND POSTPROCESSING .....</b>	<b>17</b>
<b>9</b>	<b>MEASUREMENT UNCERTAINTY .....</b>	<b>18</b>
<b>10</b>	<b>RF EMISSIONS TESTS.....</b>	<b>19</b>
10.1	EMISSION LIMITS.....	19
10.2	CDMA 800 TEST RESULTS.....	20
10.3	CDMA 1900 TEST RESULTS.....	21
10.4	WORST-CASE CONFIGURATION EVALUATION.....	22
<b>11</b>	<b>APPENDIX A: PROBE CALIBRATION CERTIFICATION .....</b>	<b>23</b>
<b>12</b>	<b>APPENDIX B: SYSTEM VALIDATION DATA PLOTS .....</b>	<b>23</b>
<b>13</b>	<b>APPENDIX C: TEST RESULTS/PLOTS.....</b>	<b>23</b>
<b>14</b>	<b>APPENDIX D: PHOTO TEST SETUP .....</b>	<b>23</b>

Applicant:	Kyocera
FCC ID:	V65E4100
Report #:	CT-E4100_20RF-0810-R1

## ATTESTATION

The tested device complies with the requirements in respect of all parameters subject to the test.  
 The test results and statements relate only to the items tested.  
 The test equipment used was suitable for the tests performed and within manufacturer's published specifications and operating parameters.  
 The test methods were consistent with the methods described in the relevant standards.

<b>Product:</b>	Dual-Band CDMA Cellular Phone with Bluetooth
<b>Model #:</b>	E4100
<b>FCC ID:</b>	V65E4100
<b>Tested in accordance with:</b>	FCC 47 CFR Part 20.19 ANSI C63.19-2007
<b>Test performed by:</b>	Comptest Services LLC
<b>Test Requested by:</b>	KYOCERA Corporation C/o KYOCERA Communications, Inc. 10300 Campus Point Drive San Diego, CA 92121 United States
<b>Date of Test:</b>	August 12-13, 2010

**Responsible Engineer**

*Benjamin Nguyen*

---

Benjamin Nguyen  
Test Engineer

**Reviewed and approved by:**



---

Tammy To  
Quality Manager

## 1 SUMMARY OF TESTING

Rule Part	Test Description	Section #	Verdict
FCC § 20.19(b), §6.3(v), §7.3(v)	HAC RF Emissions	4	Pass
ANSI C63.19-2007 HAC M Category:		M4	

## 2 EQUIPMENT UNDER TEST INFORMATION

<b>Product:</b>	Dual-Band CDMA Cellular Phone with Bluetooth	
<b>FCC ID:</b>	V65E4100	
<b>Model Number:</b>	E4100	
<b>EUT Serial Number:</b>	4100D049	
<b>Type:</b>	<input type="checkbox"/> Identical Prototype, <input checked="" type="checkbox"/> Pre-Production, <input type="checkbox"/> Production	
<b>Device Category:</b>	Portable	
<b>RF Exposure Environment:</b>	General Population / Uncontrolled	
<b>Antenna:</b>	Internal	
<b>Detachable Antenna:</b>	Yes	
<b>External Input:</b>	Audio/Digital Data	
<b>Quantity:</b>	Quantity production is planned	
<b>Modes:</b>	800 CDMA	1900 CDMA
<b>Multiple Access Scheme:</b>	CDMA	CDMA
<b>TX Frequency (MHz):</b>	824 – 849	1850 - 1910
<b>Rated RF Conducted Output Power (dBm)</b>	25.0	25.2

### 3 TEST CONDITIONS

#### 3.1 Ambient Conditions

All tests were performed under the following environmental conditions:

Ambient Temperature:	23 ± 2 Degrees C
Tissue simulating liquid temperature:	22 ± 1 Degrees C
Relative Humidity (RH):	0% <RH < 80%
Atmospheric Pressure:	101.3kPa + 10 to -5 kPa

#### 3.2 RF characteristics of the test site

All HAC measurements were performed inside a shielded room that provide isolation from external EM fields, with the RF ambient at least 20 dB below the intended measurement limits.

#### 3.3 Test Signal, Frequencies and Output Power

The device supports CDMA2000 in 1X (Phase I, Protocol revision 6) mode only. CDMA2000 1X includes TIA/EIA-95B as a subset and was approved for publishing in July 1999. It provides voice and data capabilities within a standard 1.25 MHz CDMA channel. This RF bandwidth is identical to the legacy IS-95 B system standard.

Peak and Average conducted power were measured to ensure worst case power configuration was tested:

CONFIGURATION (Full Rate)		CONDUCTED POWER	
		CDMA 800 (ch 383)	CDMA 1900 (ch 600)
		Average (dBm)	Average (dBm)
SO2	RC1	25.05	25.19
	RC3	25.00	25.16
SO55	RC1	25.05	25.17
	RC3	<b>25.06</b>	<b>25.20</b>
SO32	RC3 (+F-SCH)	25.02	25.15
	RC3 (+SCH)	25.04	25.16

In all operating modes, the phone was set to rated maximum RF power level and the measurements were performed on low, mid and high channels.

The measurement system measures power drift during HAC testing by comparing E/H-field in the same location at the beginning and at the end of measurement. These records were used to monitor stability of power output during tests. Conducted RF power measurements were also performed before and after each HAC measurements to confirm the output power.



Applicant:	Kyocera
FCC ID:	V65E4100
Report #:	CT-E4100_20RF-0810-R1

During tests, the EUT was put in in-call mode and controlled by a CDMA simulator to generate the required signal and power:

Protocol:	6 (IS-2000)
Radio Configuration:	3
Power Control:	All Up Bits
Service Option:	55
Data Rate:	Full

### 3.4 EUT Operating Conditions

The EUT was tested with the follow configurations and conditions, if applicable:

- Fully charged standard battery as supplied with the handset
- Closed configurations at ear use position <sup>1</sup>
- Both retracted and extended antenna positions
- Back-light always ON
- Simultaneous transmission with Bluetooth transmitter ON <sup>2</sup>

*Note: \*The Bluetooth transmitter was not enable during tests, since the intended use of the CDMA transmitter does not include support simultaneous operation when held to ear.*

## 4 DESCRIPTION OF TEST EQUIPMENT

### 4.1 Test Equipment Used

Below is a list of the calibrated equipment used for the measurements.

*The calibration certificates of E-field and H-field probes are attached in Appendix A.*

Description	Manufacturer	Model Number	Serial Number	Cal Due Date
Power Meter	Giga-tronics	8541C	1831306	07/16/11
Signal Generator	Hewlett Packard	E4421B	US38440337	07/15/11
Radio Communication Tester	Agilent	8960	GB44052789	08/14/10
Data Acquisition	Speag	DAE4	527	07/09/11
E-field Probe	Speag	ER3DV6	2341	07/12/11
H-field Probe	Speag	H3DV5	6029	07/16/12
Dipole Antenna (835MHz)	Speag	CD835V3	1020	04/26/11
Dipole Antenna (1880MHz)	Speag	CD1880V3	1015	04/26/11

*Note: Dipoles are calibrated on a 2-year interval. Dipoles return-loss and input impedances are measured annually (50824 DO2 Dipole SAR Validation Verification v01).*

### 4.2 Near Field Measurement System

The measurements were performed with Dasy4 automated near-field scanning system comprised of high precision robot, robot controller, computer, near-field probe, probe alignment sensor, non-conductive phone positioner, Test Arch and software extension. The overall expanded uncertainty (K=2) of the measurement system is  $\pm 10.9\%$  and  $\pm 14.7\%$  for H-field and E-field resp. The measurement uncertainty budget is given in section 6.



### 4.3 Isotropic E-Field Probe

<b>Model</b>	▪ ER3DV6
<b>Construction</b>	<ul style="list-style-type: none"> <li>▪ One dipole parallel, two dipoles normal to probe axis</li> <li>▪ Built-in shielding against static charges</li> <li>▪ PEEK enclosure material (resistant to organic solvents, e.g., glycoether)</li> </ul>
<b>Calibration</b>	▪ In air from 100 MHz to 3.0 GHz (absolute accuracy $\pm 6\%$ ; k=2)
<b>Frequency</b>	<ul style="list-style-type: none"> <li>▪ 100MHz to 6 GHz</li> <li>▪ Linearity: <math>\pm 0.2\text{dB}</math> (100MHz to 3GHz)</li> </ul>
<b>Directivity</b>	<ul style="list-style-type: none"> <li>▪ <math>\pm 0.2</math> dB in air (rotation around probe axis)</li> <li>▪ <math>\pm 0.4</math> dB in air (rotation normal to probe axis)</li> </ul>
<b>Dynamic Range</b>	<ul style="list-style-type: none"> <li>▪ 2 V/m to &gt; 1000 V/m</li> <li>▪ Linearity: <math>\pm 0.2</math> dB</li> </ul>
<b>Dimensions</b>	<ul style="list-style-type: none"> <li>▪ Overall length: 330 mm (Tip: 16 mm)</li> <li>▪ Tip diameter: 8 mm (Body: 12 mm)</li> <li>▪ Distance from probe tip to dipole centers: 2.5 mm</li> </ul>
<b>Application</b>	<ul style="list-style-type: none"> <li>▪ General near-field measurements up to 6 GHz</li> <li>▪ Field component measurements</li> <li>▪ Fast automatic scanning in phantoms</li> </ul>

### 4.4 Isotropic -Field Probe

<b>Model</b>	▪ H3DV6
<b>Construction</b>	<ul style="list-style-type: none"> <li>▪ Three concentric loop sensors with 3.8 mm loop diameters</li> <li>▪ Resistively loaded detector diodes for linear response</li> <li>▪ Built-in shielding against static charges</li> <li>▪ PEEK enclosure material (resistant to organic solvents, e.g., glycoether)</li> </ul>
<b>Frequency</b>	▪ 200 MHz to 3 GHz ( $\pm 6.0\%$ , k=2); Output linearized
<b>Directivity</b>	▪ $\pm 0.25$ dB (spherical isotropy error)
<b>Dynamic Range</b>	▪ 10 mA/m to 2 A/m at 1 GHz
<b>E-Field Interference</b>	▪ < 10% at 3 GHz (for plane wave)
<b>Dimensions</b>	<ul style="list-style-type: none"> <li>▪ Overall length: 330 mm (Tip: 40 mm)</li> <li>▪ Tip diameter: 6 mm (Body: 12 mm)</li> <li>▪ Distance from probe tip to dipole centers: 3 mm</li> </ul>
<b>Application</b>	<ul style="list-style-type: none"> <li>▪ General magnetic near-field measurements up to 3 GHz</li> <li>▪ Field component measurements</li> <li>▪ Surface current measurements</li> <li>▪ Measurements in air or liquids</li> <li>▪ Low interaction with the measured field</li> </ul>



## 5 SYSTEM VALIDATION

### 5.1 Dipole Validation Setup

The probes are calibrated annually by the manufacturer. The HAC measurements of the device were done within 24 hours of system accuracy verification, which was done using calibration dipoles. Unmodulated continuous wave of power level of 20dBm was supplied to a dipole antenna placed under Test Arch. The measurement probes are positioned over the illuminated dipole at 10mm distance from the top surface of the dipole element to the calibration reference point of the sensor, defined by the probe manufacturer.

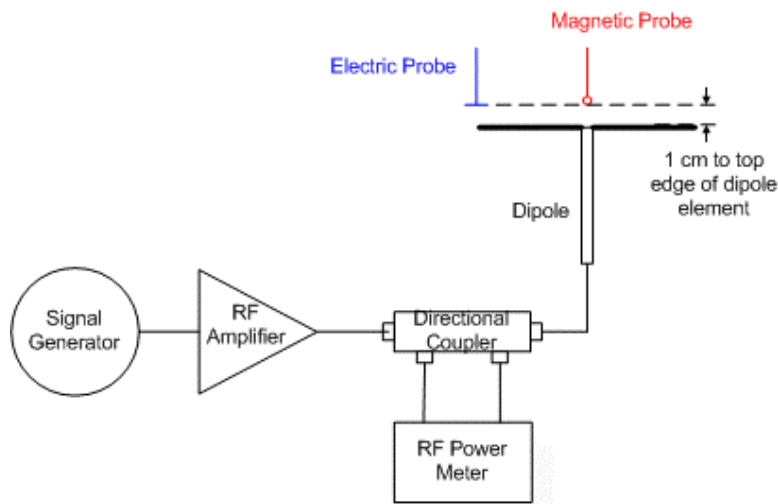

Figure 5 System Check Setup

## 5.2 Dipole Validation Results

The length of the dipole was scanned with both E and H-field probes and the maximum values for each were recorded. The validation results are in the table below and printouts of the validation test are attached in Appendix B. All the measured parameters were within the specification.

Freq. (MHz)	Parameter	Target (SPEAG)	Measured	Delta (%)	Limit (%)	Test date
835	E dB(V/m)	159.5	164.7	3.26	± 25	08/12/10
	H dB(A/m)	0.458	0.457	-0.28	± 25	08/13/10
1880	E dB(V/m)	140.4	136.7	-2.64	± 25	08/12/10
	H dB(A/m)	0.466	0.475	1.82	± 25	08/13/10

## 6 DESCRIPTION OF TEST PROCEDURE

### 6.1 Test Positions

The device was placed on a non-conductive phone positioner under the Test Arch.

### 6.2 RF Emission Measurements Reference and Plane

Figure 6.2 illustrates the references and reference plane that shall be used in the EUT emissions measurement:

- The grid is 5 cm by 5 cm area that is divided into 9 evenly sized blocks or sub-grids.
- The grid is centered on the audio frequency output transducer (speaker) of the EUT.
- The grid is in a reference plane, which is defined as the planar area that contains the highest point in the area of the phone that normally rests against the user's ear. It is parallel to the centerline of the receiver of the EUT and is defined by the points of the receiver-end of the EUT, which, in normal handset use, rest against the ear.
- The measurement plane is parallel to, and 1.5 cm in front of, the reference plane.

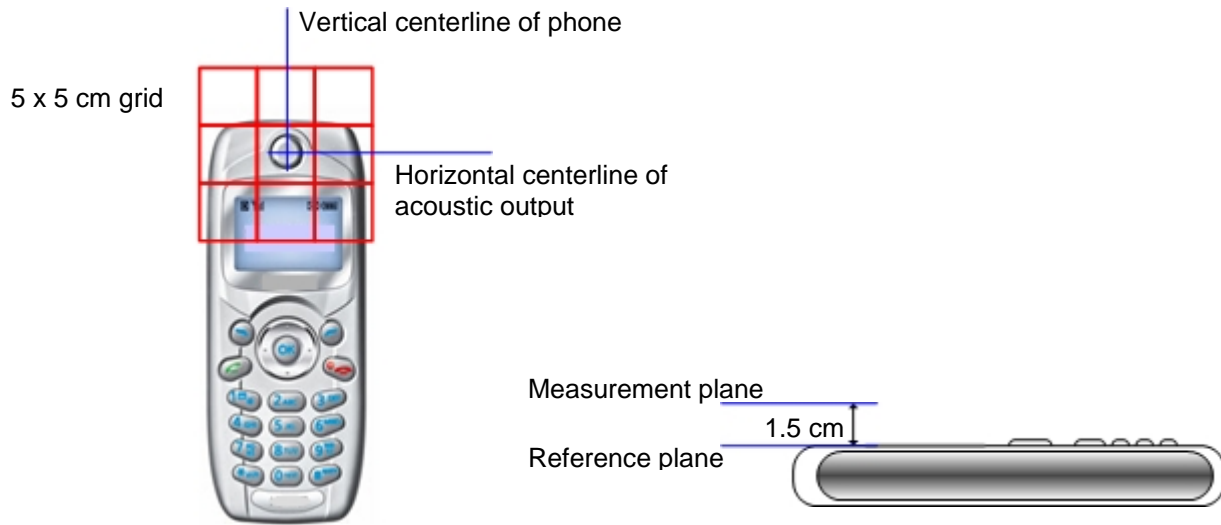

Figure 6.2 – Measurement Reference and Plane



Applicant:	Kyocera
FCC ID:	V65E4100
Report #:	CT-E4100_20RF-0810-R1

### 6.3 RF Emissions Measurement Procedures

Flowchart below shows the near field emission measurement:

1. The center of the probe was scan to the edges of the grid. Accordingly the total area covered by the outside edge of the probe was the 5 cm by 5 cm area, increased by half ( $\frac{1}{2}$ ) the probe diameter on all sides.
2. The nearest point on the probe measurement element(s) was held 1.0 cm from the EUT reference plane.
3. The probe element is that portion of the probe that is designed to receive and sense the field being measured.
4. The physical body of the probe housing was not used when setting this 1.0 cm distance as this would place the sensing elements at an indeterminate distance from the reference plane.
5. The step size of the scan is set to 5 mm or less.
6. Up to three blocks were excluded for each field measurement.
  - The center block containing the EUT output was not excluded.
  - A maximum of five blocks were excluded for both E- and H-field measurements for the EUT output being measured. Stated differently, the center sub-grid or block and 3 other blocks were common to both the E- and H-field measurements for a given grid.

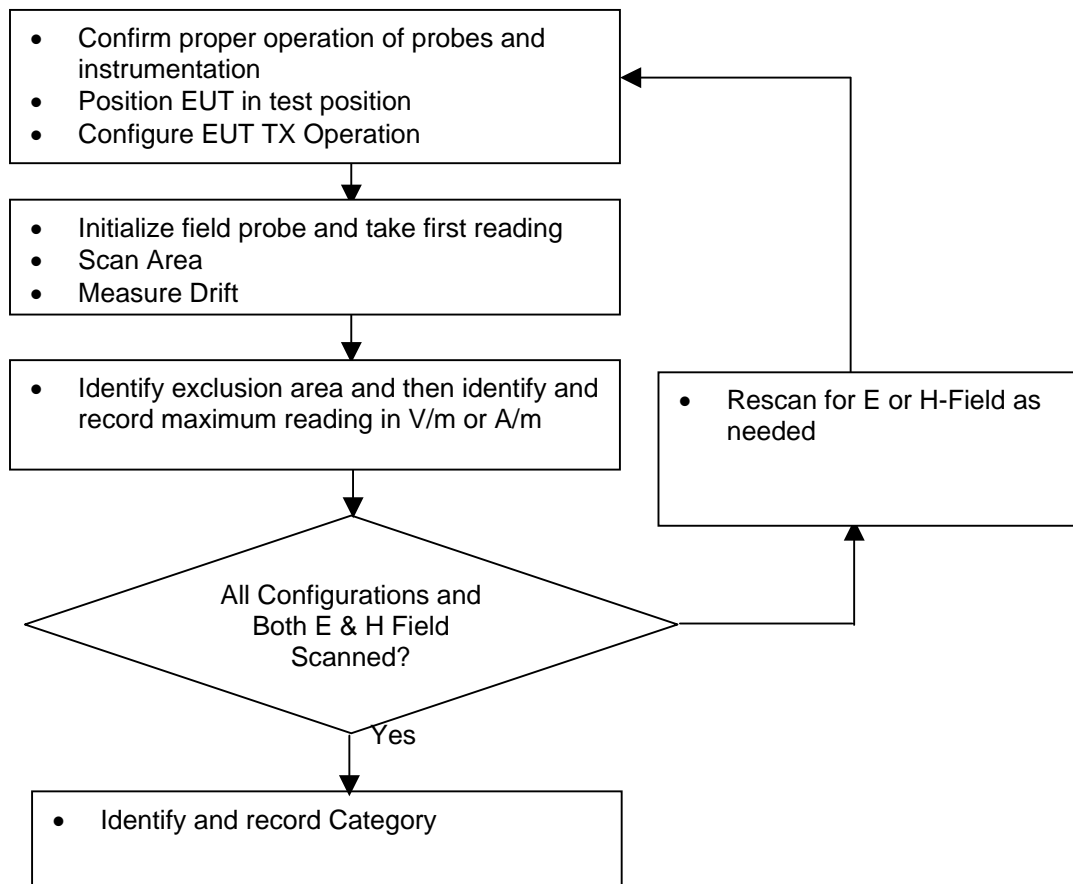

Figure 7.6 Near field emission measurement flowchart

## 7 PROBE MODULATION FACTOR (PMF)

### 7.1 PMF Measurement Procedures

A calibration was made of the modulation response of the probe and its instrumentation chain. This calibration was performed with the field probe, attached to its instrumentation. The response of the probe system to a CW field at the frequency of interest is compared to its response to a modulated signal with equal peak amplitude to that of a CW signal. The field level of the test signals shall be more than 10 dB above the ambient level and the noise floor of the instrumentation being used. The ratio of the CW reading to that taken with a modulated reading was applied to the DUT measurements. The measurement procedures are as following:

1. Fix the field probe in a set location relative to the dipole antenna, as illustrated in Figure 7.4.
2. Setup the wireless device (EUT) with intended signal at the intended measurement frequency.
3. Record the reading of the probe measurement system.
4. Replace the wireless device with a RF signal generator producing an unmodulated CW signal and set to the wireless device operating frequency.
5. Set the peak power of the unmodulated signal to equal that recorded from the wireless device
6. Record the reading of the probe measurement system of the unmodulated CW signal.
7. The ratio of probe reading (CW) in step 6 to the probe reading (EUT) in step 3 is the modulation factor.

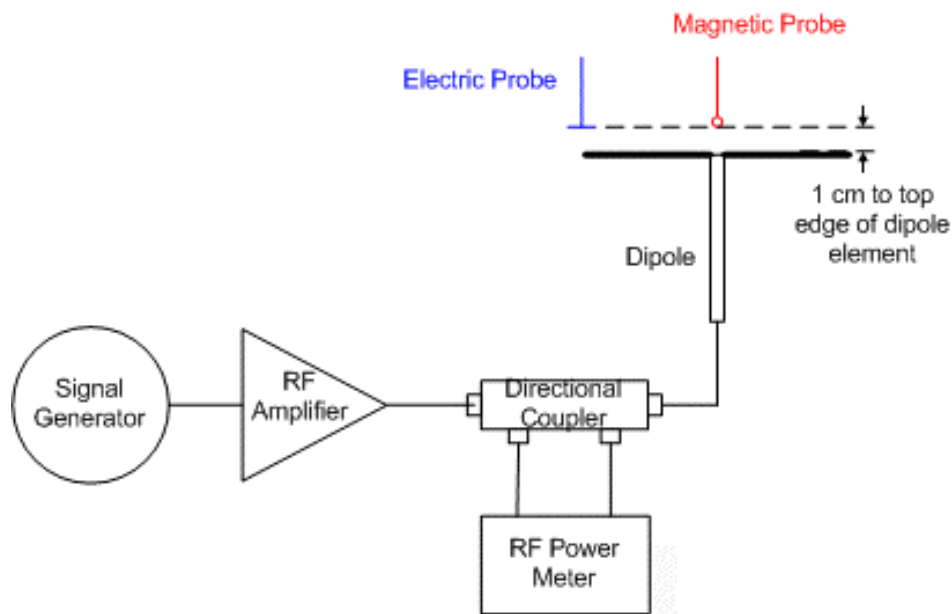

Figure 7.4

## 7.2 PMF Test Results

The modulation factors obtained by above method shall be applied to readings taken of the actual WD, in order to obtain an accurate peak field reading.

E-Field				
Frequency (MHz)	Peak Power (dBm)	Protocol	Protocol Reading (V/m)	Modulation Factor
835	24.32	CW	127.6	
	24.3	CDMA (full rate)	127.4	1.00
	24.32	AM	77.77	1.64
1880	22.92	CW	69.51	
	22.92	CDMA (full rate)	70.66	0.98
	22.92	AM	44.42	1.56
H-Field				
Frequency (MHz)	Peak Power (dBm)	Protocol	Protocol Reading (A/m)	Modulation Factor
835	24.5	CW	0.343	
	24.5	CDMA (full rate)	0.335	1.02
	24.61	AM	0.223	1.54
1880	22.92	CW	0.272	
	22.94	CDMA (full rate)	0.277	0.98
	22.92	AM	0.173	1.57



Applicant:	Kyocera
FCC ID:	V65E4100
Report #:	CT-E4100_20RF-0810-R1

### 7.3 PMF Peak Power Measurement Plots

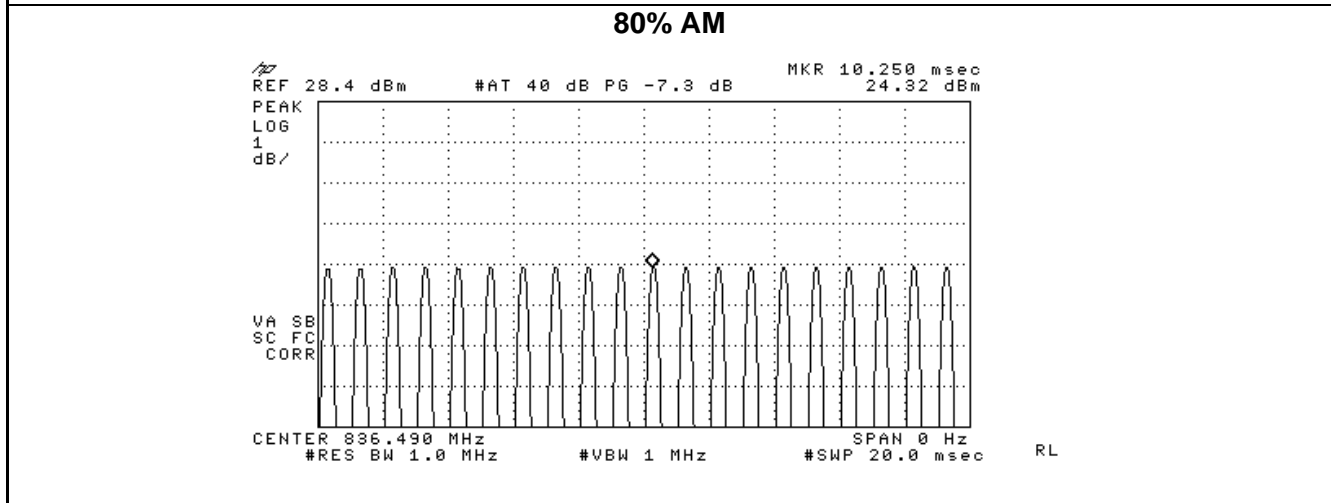
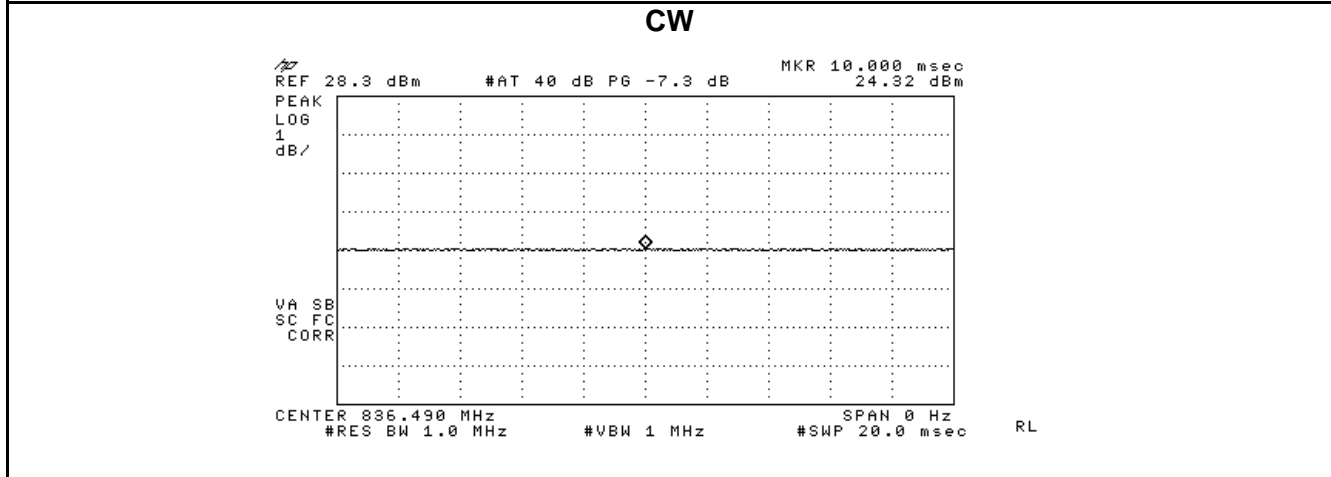
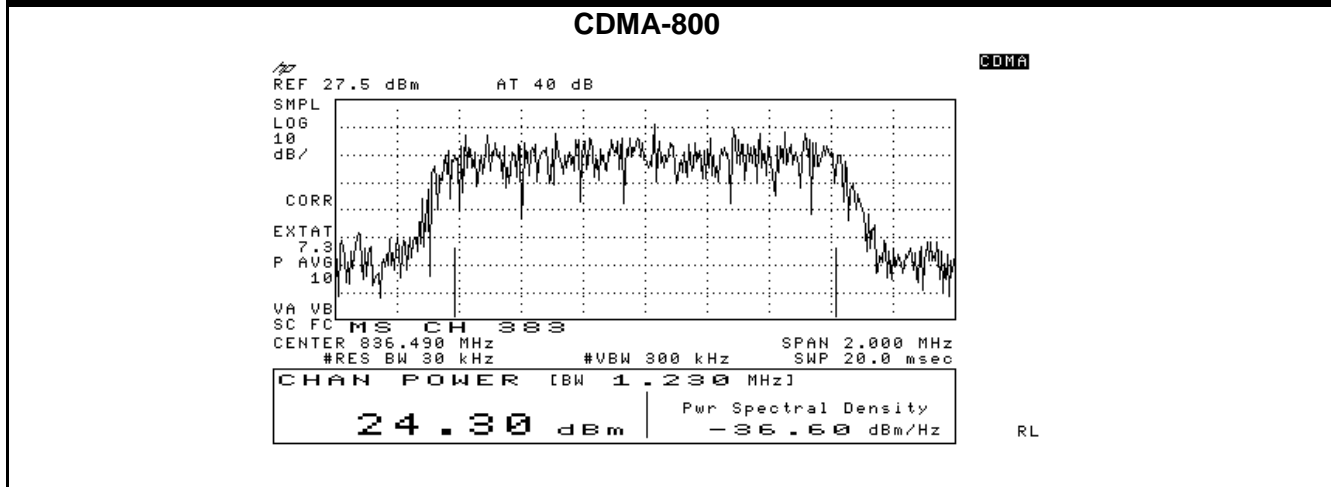



Applicant:	Kyocera
FCC ID:	V65E4100
Report #:	CT-E4100_20RF-0810-R1

**CDMA-1880**

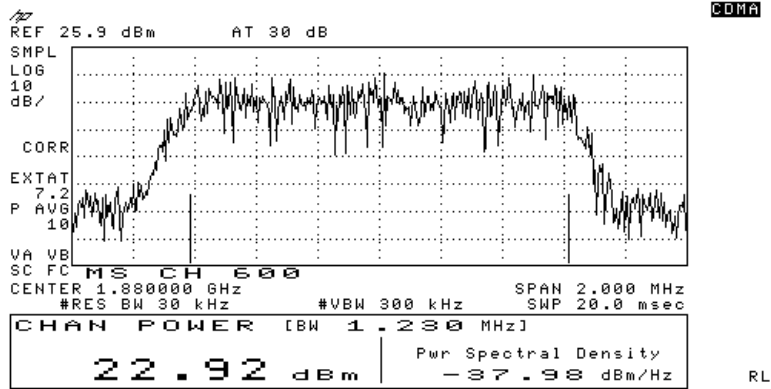

**CW**

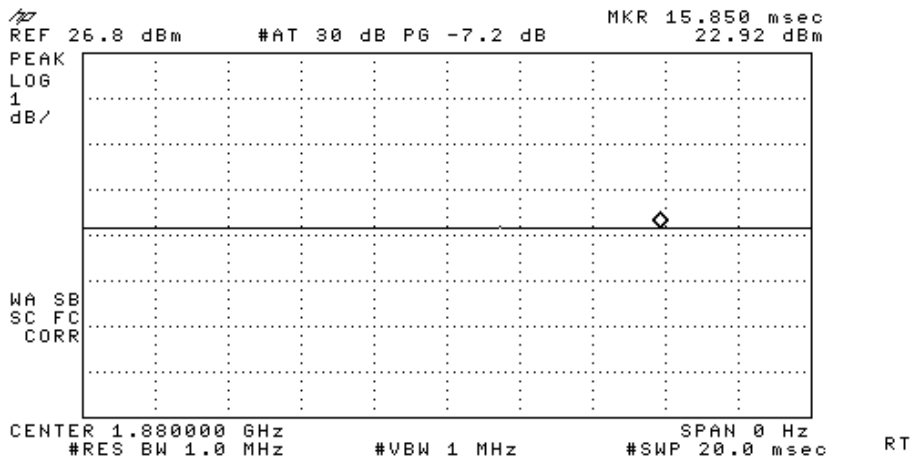

**80% AM**

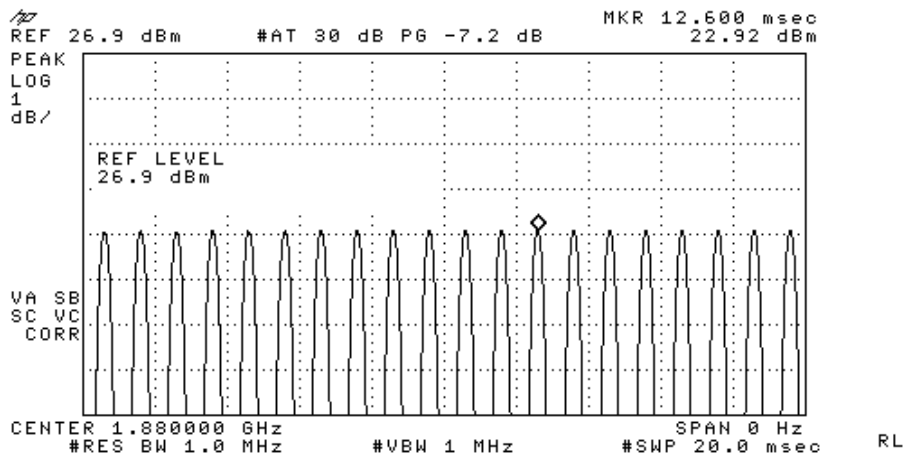



## 8 EMISSION DATA EXTRACTION AND POSTPROCESSING

At the end of the measurements, the DASY4 system automatically evaluates the slot-averaged results, exclusion of the three highest subgrid, application of the AWF factor per ANSI-C63.19 requirements.

The following AWF factors were used for the standard transmission protocols:

Standard	Technology	AWF
TIA/EIA/IS-2000	CDMA	0
TIA/EIA-136	TDMA (50 Hz)	0
J-STD-007	GSM (217)	-5
T1/T1P1/3GPP	UMTS (WCDMA)	0
iDEN™	TDMA(22 and 11 Hz)	0

Table 8.1 Articulation Weighting Factor (AWF)

All DASY4 measurements are in RMS values. The Dasy4 system incorporates the crest factor of the signal in the computation of the RMS values. Although the software also has the capability to estimate the peak field by applying a square root of the crest factor value to the readings, the probe modulation factor was applied manually instead per ANSI C63.19 in the measurement tables in this report using equation:

$$\text{Peak Field} = (\text{DASY4 reading}) \times \text{PMF}$$

where DASY4 reading = measurement from DASY4 in V/m or A/m  
 PMF = Probe Modulation Factor in linear unit

## 9 MEASUREMENT UNCERTAINTY

Table 8.1 shows the uncertainty budget for HAC free field assessment according to ANSI C63.19-2007. The budget is valid for the frequency range 800 MHz - 3 GHz and represents a worst-case analysis. For specific tests and configurations, the uncertainty could be smaller.

Uncertainty Description	Uncert. Value (± %)	Prob. Dist.	Div.	C <sub>i</sub> (E)	C <sub>i</sub> (H)	Stand. Uncert (E) (±%)	Stand. Uncert (H) (±%)
<b>Measurement system</b>							
Probe calibration	5.1	N	1	1	1	5.1	5.1
Axial isotropy of the probe	4.7	R	√3	1	1	2.7	2.7
Sensor displacement	16.5	R	√3	1	0.145	9.5	1.4
Boundary effects	2.4	R	√3	1	1	1.4	1.4
Probe linearity	4.7	R	√3	1	1	2.7	2.7
Scaling to Peak Envelope Power	2.0	R	√3	1	1	1.2	1.2
System Detection limit	1.0	R	√3	1	1	0.6	0.6
Readout electronics	0.3	N	1	1	1	0.3	0.3
Response time	0.8	R	√3	1	1	0.5	0.5
Integration time	2.6	R	√3	1	1	1.5	1.5
RF ambient conditions	3.0	R	√3	1	1	1.7	1.7
RF Reflections	12	R	√3	1	1	6.9	6.9
Probe Positioner	1.2	R	√3	1	0.67	0.7	0.5
Probe positioning	4.7	R	√3	1	0.67	2.7	1.8
Extrap. and integration	1.0	R	√3	1	1	0.6	0.6
<b>Test Sample Related</b>							
Device positioning vertical	4.7	R	√3	1	0.67	2.7	1.8
Device Positioning Lateral	1.0	R	√3	1	1	0.6	0.6
Device Holder and Phantom	2.4	R	√3	1	1	1.4	1.4
Power drift	5.0	R	√3	1	1	2.9	2.9
<b>Phantom and Setup Related</b>							
Phantom thickness	2.4	R	√3	1	0.67	1.4	0.9
<b>Combined Standard Uncertainty:</b>						14.7	10.9
<b>Extended Standard Uncertainty on Power (k=2):</b>						29.4	21.8
<b>Extended Standard Uncertainty on Field (k=2):</b>						<b>14.7</b>	<b>10.9</b>

N: Normal  
 R: Rectangular

Table 9.1 Worst-Case uncertainty budget for HAC free field assessment

## 10 RF EMISSIONS TESTS

### 10.1 Emission Limits

**FCC: § 20.19, ANSI C63.19-2007**

**IC:**

Table 10.1 shows the M-rating criteria from ANSCI C63.19. All digital transmission modes in all frequency bands contained in a HAC phone must meet M3 or M4 levels.

Near Field	Wireless Device RF Parameters [AWF = 0]			
	E-Field Emissions		H-Field Emissions	
Category	dB(V/m) Peak	V/m Peak	dB(A/m) Peak	A/m Peak
<b>Freq &lt; 960 MHz</b>				
M1	56.0 to 61.0	631.0 to 1122.0	5.6 to 10.6	1.91 to 3.39
M2	51.0 to 56.0	354.8 to 631.0	0.6 to 5.6	1.07 to 1.91
<b>M3</b>	46.0 to 51.0	199.5 to 354.8	-4.4 to 0.6	0.60 to 1.07
<b>M4</b>	< 46.0	< 199.5	< -4.4	< 0.60
<b>Freq &gt; 960 MHz</b>				
M1	46.0 to 51.0	199.5 to 354.8	-4.4 to 0.6	0.60 to 1.07
M2	41.0 to 46.0	112.2 to 199.5	-9.4 to -4.4	0.34 to 0.60
<b>M3</b>	36.0 to 41.0	63.1 to 112.2	-14.4 to -9.4	0.19 to 0.34
<b>M4</b>	< 36.0	< 63.1	< -14.4	< 0.19

Table 10.1 RF Emission Limits

## 10.2 CDMA 800 Test Results

<b>Configuration:</b>	Standard Battery			<b>Antenna:</b>	Fixed	
CDMA 800 E-Field						
Ch.	Backlight	Power	Dasy4 Reading	PMF	Peak Field	Category
#		dBm	V/m		V/m	M
1013	ON	25.14	45.4	1.00	45.4	4
383	ON	25.06	61.2	1.00	61.2	4
777	ON	24.97	52.7	1.00	52.7	4
CDMA 800 H-Field						
Ch.	Backlight	Power	Dasy4 Reading	PMF	Peak Field	Category
#		dBm	A/m		A/m	M
1013	ON	25.14	0.091	1.00	0.091	4
384	ON	25.06	0.102	1.00	0.102	4
777	ON	24.97	0.079	1.00	0.079	4

### 10.3 CDMA 1900 Test Results

<b>Configuration:</b>	Standard Battery			<b>Antenna:</b>	Fixed	
CDMA 1900 E-Field						
Ch.	Backlight	Power	Dasy4 Reading	PMF	Peak Field	Category
#		dBm	V/m		V/m	M
25	ON	25.29	36.5	1.00	36.5	4
600	ON	25.20	42.0	1.00	42.0	4
1175	ON	25.30	40.8	1.00	40.8	4
CDMA 1900 H-Field						
Ch.	Backlight	Power	Dasy4 Reading	PMF	Peak Field	Category
#		dBm	A/m		A/m	M
25	ON	25.29	0.129	1.00	0.129	4
600	ON	25.20	0.144	1.00	0.144	4
1175	ON	25.30	0.134	1.00	0.134	4

## 10.4 Worst-Case Configuration Evaluation

The probe was rotated 360° at Azimuth axis in the worst case configuration. The rotation was performed at the location of maximum field strength in the included blocks.

CDMA 800 E-Field						
<b>Configuration:</b>		Standard Battery		<b>Antenna:</b>	Fixed	
Ch. #	Backlight	Conducted Power dBm	Peak Field V/m	PMF	Peak Field V/m	Category M
383	ON	25.06	62.6	1.00	62.6	4

CDMA 1900 E-Field						
<b>Configuration:</b>		Standard Battery		<b>Antenna:</b>	Fixed	
Ch. #	Backlight	Conducted Power dBm	Peak Field V/m	PMF	Peak Field V/m	Category M
600	ON	25.20	41.54	1.00	41.54	4

Data plots are shown in Appendix C

## 11 APPENDIX A: PROBE CALIBRATION CERTIFICATION

(See attachment)

## 12 APPENDIX B: SYSTEM VALIDATION DATA PLOTS

(See attachment)

## 13 APPENDIX C: TEST RESULTS/PLOTS

(See attachment)

## 14 APPENDIX D: PHOTO TEST SETUP

(See attachment)