



# FCC TEST REPORT (15.247)

**REPORT NO.:** RF130223C16-4  
**MODEL NO.:** C6750  
**FCC ID:** V65C6750  
**RECEIVED:** Feb. 23, 2013  
**TESTED:** Mar. 11, 2013 ~ Mar. 16, 2013  
**ISSUED:** Mar. 25, 2013

**APPLICANT:** Kyocera Communications, Inc.

**ADDRESS:** 8611 Balboa Ave., San Diego, CA 92123, USA

**ISSUED BY:** Bureau Veritas Consumer Products Services  
(H.K.) Ltd., Taoyuan Branch

**LAB ADDRESS:** No. 47, 14th Ling, Chia Pau Vil., Lin Kou Dist.,  
New Taipei City, Taiwan ( R.O.C )

**TEST LOCATION:** No. 19, Hwa Ya 2nd Rd, Wen Hwa Tsuen, Kwei  
Shan Hsiang, Taoyuan Hsien 333, Taiwan, R.O.C.

This report should not be used by the client to claim product certification, approval, or endorsement by TAF or any government agencies.



This report is for your exclusive use. Any copying or replication of this report to or for any other person or entity, or use of our name or trademark, is permitted only with our prior written permission. This report sets forth our findings solely with respect to the test samples identified herein. The results set forth in this report are not indicative or representative of the quality or characteristics of the lot from which a test sample was taken or any similar or identical product unless specifically and expressly noted. Our report includes all of the tests requested by you and the results thereof based upon the information that you provided to us. You have 60 days from date of issuance of this report to notify us of any material error or omission caused by our negligence, provided, however, that such notice shall be in writing and shall specifically address the issue you wish to raise. A failure to raise such issue within the prescribed time shall constitute your unqualified acceptance of the completeness of this report, the tests conducted and the correctness of the report contents. Unless specific mention, the uncertainty of measurement has been explicitly taken into account to declare the compliance or non-compliance to the specification.



Table of Contents

RELEASE CONTROL RECORD .....4

1. CERTIFICATION.....5

2. SUMMARY OF TEST RESULTS .....6

2.1 MEASUREMENT UNCERTAINTY.....6

3. GENERAL INFORMATION.....7

3.1 GENERAL DESCRIPTION OF EUT .....7

3.2 DESCRIPTION OF TEST MODES.....8

3.2.1 TEST MODE APPLICABILITY AND TESTED CHANNEL DETAIL.....9

3.3 DESCRIPTION OF SUPPORT UNITS .....13

3.3.1 CONFIGURATION OF SYSTEM UNDER TEST .....13

3.4 GENERAL DESCRIPTION OF APPLIED STANDARDS .....13

4. TEST TYPES AND RESULTS (FOR 2.4GHz BAND).....14

4.1 RADIATED EMISSION AND BANDEDGE MEASUREMENT .....14

4.1.1 LIMITS OF RADIATED EMISSION AND BANDEDGE MEASUREMENT .....14

4.1.2 TEST INSTRUMENTS.....15

4.1.3 TEST PROCEDURES .....16

4.1.4 DEVIATION FROM TEST STANDARD .....16

4.1.5 TEST SETUP .....17

4.1.6 EUT OPERATING CONDITIONS .....17

4.1.7 TEST RESULTS .....18

4.2 CONDUCTED EMISSION MEASUREMENT .....28

4.2.1 LIMITS OF CONDUCTED EMISSION MEASUREMENT .....28

4.2.2 TEST INSTRUMENTS.....28

4.2.3 TEST PROCEDURES .....29

4.2.4 DEVIATION FROM TEST STANDARD .....29

4.2.5 TEST SETUP .....30

4.2.6 EUT OPERATING CONDITIONS .....30

4.2.7 TEST RESULTS .....31

4.3 6dB BANDWIDTH MEASUREMENT .....35

4.3.1 LIMITS OF 6dB BANDWIDTH MEASUREMENT .....35

4.3.2 TEST SETUP .....35

4.3.3 TEST INSTRUMENTS.....35

4.3.4 TEST PROCEDURE .....35

4.3.5 DEVIATION FROM TEST STANDARD .....35

4.3.6 EUT OPERATING CONDITIONS .....35

4.3.7 TEST RESULTS .....36

4.4 CONDUCTED OUTPUT POWER .....37

4.4.1 LIMITS OF CONDUCTED OUTPUT POWER MEASUREMENT .....37

4.4.2 TEST SETUP .....37

4.4.3 TEST INSTRUMENTS.....38

4.4.4 TEST PROCEDURES .....38

4.4.5 DEVIATION FROM TEST STANDARD .....38

4.4.6 EUT OPERATING CONDITIONS .....38

4.4.7 TEST RESULTS .....39

4.5 POWER SPECTRAL DENSITY MEASUREMENT.....40

4.5.1 LIMITS OF POWER SPECTRAL DENSITY MEASUREMENT .....40

4.5.2 TEST SETUP .....40

4.5.3 TEST INSTRUMENTS.....40

4.5.4 TEST PROCEDURE .....40

4.5.5 DEVIATION FROM TEST STANDARD .....40

4.5.6 EUT OPERATING CONDITION .....40

4.5.7 TEST RESULTS .....41

4.6 CONDUCTED OUT OF BAND EMISSION MEASUREMENT .....42

4.6.1 LIMITS OF CONDUCTED OUT OF BAND EMISSION MEASUREMENT .....42

4.6.2 TEST SETUP .....42

4.6.3 TEST INSTRUMENTS.....42



4.6.4	TEST PROCEDURE.....	42
4.6.5	DEVIATION FROM TEST STANDARD .....	43
4.6.6	EUT OPERATING CONDITION .....	43
4.6.7	TEST RESULTS .....	43
5.	TEST TYPES AND RESULTS (FOR 5.0GHz BAND).....	47
5.1	RADIATED EMISSION AND BANDEDGE MEASUREMENT .....	47
5.1.1	LIMITS OF RADIATED EMISSION AND BANDEDGE MEASUREMENT .....	47
5.1.2	TEST INSTRUMENTS.....	48
5.1.3	TEST PROCEDURES .....	48
5.1.4	DEVIATION FROM TEST STANDARD .....	48
5.1.5	TEST SETUP.....	48
5.1.6	EUT OPERATING CONDITIONS .....	48
5.1.7	TEST RESULTS .....	49
5.2	CONDUCTED EMISSION MEASUREMENT .....	58
5.2.1	LIMITS OF CONDUCTED EMISSION MEASUREMENT .....	58
5.2.2	TEST INSTRUMENTS.....	58
5.2.3	TEST PROCEDURES .....	58
5.2.4	DEVIATION FROM TEST STANDARD .....	58
5.2.5	TEST SETUP.....	58
5.2.6	EUT OPERATING CONDITIONS .....	58
5.2.7	TEST RESULTS .....	59
5.3	6dB BANDWIDTH MEASUREMENT .....	63
5.3.1	LIMITS OF 6dB BANDWIDTH MEASUREMENT .....	63
5.3.2	TEST SETUP.....	63
5.3.3	TEST INSTRUMENTS.....	63
5.3.4	TEST PROCEDURE.....	63
5.3.5	DEVIATION FROM TEST STANDARD .....	63
5.3.6	EUT OPERATING CONDITIONS .....	63
5.3.7	TEST RESULTS .....	64
5.4	MAXIMUM OUTPUT POWER .....	65
5.4.1	LIMITS OF MAXIMUM OUTPUT POWER MEASUREMENT .....	65
5.4.2	TEST SETUP.....	65
5.4.3	INSTRUMENTS.....	65
5.4.4	TEST PROCEDURES .....	65
5.4.5	DEVIATION FROM TEST STANDARD .....	65
5.4.6	EUT OPERATING CONDITIONS .....	65
5.4.7	TEST RESULTS .....	66
5.5	POWER SPECTRAL DENSITY MEASUREMENT.....	67
5.5.1	LIMITS OF POWER SPECTRAL DENSITY MEASUREMENT .....	67
5.5.2	TEST SETUP.....	67
5.5.3	TEST INSTRUMENTS.....	67
5.5.4	TEST PROCEDURE.....	67
5.5.5	DEVIATION FROM TEST STANDARD .....	67
5.5.6	EUT OPERATING CONDITION .....	67
5.5.7	TEST RESULTS .....	68
5.6	CONDUCTED OUT OF BAND EMISSION MEASUREMENT .....	69
5.6.1	LIMITS OF OUT OF BAND EMISSION MEASUREMENT .....	69
5.6.2	TEST SETUP.....	69
5.6.3	TEST INSTRUMENTS.....	69
5.6.4	TEST PROCEDURE.....	69
5.6.5	DEVIATION FROM TEST STANDARD .....	69
5.6.6	EUT OPERATING CONDITION .....	69
5.6.7	TEST RESULTS .....	69
6.	PHOTOGRAPHS OF THE TEST CONFIGURATION .....	73
7.	INFORMATION ON THE TESTING LABORATORIES.....	74
8.	APPENDIX A - Modifications recorders for engineering changes to the eut BY THE LAB .....	75



A D T

## RELEASE CONTROL RECORD

ISSUE NO.	REASON FOR CHANGE	DATE ISSUED
RF130223C16-4	Original release	Mar. 25, 2013



## 1. CERTIFICATION

**PRODUCT:** PDA Phone  
**MODEL NO.:** C6750  
**BRAND:** Kyocera  
**APPLICANT:** Kyocera Communications, Inc.  
**TESTED:** Mar. 11, 2013 ~ Mar. 16, 2013  
**TEST SAMPLE:** Identical Prototype  
**STANDARDS:** **FCC Part 15, Subpart C (Section 15.247)**  
ANSI C63.10-2009

The above equipment (model: C6750) has been tested by **Bureau Veritas Consumer Products Services (H.K.) Ltd., Taoyuan Branch**, and found compliance with the requirement of the above standards. The test record, data evaluation & Equipment Under Test (EUT) configurations represented herein are true and accurate accounts of the measurements of the sample's EMC characteristics under the conditions specified in this report.

**PREPARED BY** : Vera Huang , **DATE** : Mar. 25, 2013  
Vera Huang / Specialist

**APPROVED BY** : Sam chen , **DATE** : Mar. 25, 2013  
Sam Chen / Assistant Manager



## 2. SUMMARY OF TEST RESULTS

The EUT has been tested according to the following specifications:

APPLIED STANDARD: FCC PART 15, SUBPART C (SECTION 15.247)			
STANDARD SECTION	TEST TYPE	RESULT	REMARK
15.207	AC Power Conducted Emission	PASS	Meet the requirement of limit. Minimum passing margin is -8.17dB at 0.47422MHz.
15.247(d) 15.209	Radiated Emissions	PASS	Meet the requirement of limit. Minimum passing margin is -9.05dB at 2388MHz.
15.247(d)	Band Edge Measurement	PASS	Meet the requirement of limit.
15.247(a)(2)	6dB bandwidth	PASS	Meet the requirement of limit.
15.247(b)	Conducted power	PASS	Meet the requirement of limit.
15.247(e)	Power Spectral Density	PASS	Meet the requirement of limit.
15.203	Antenna Requirement	PASS	No antenna connector is used.

### 2.1 MEASUREMENT UNCERTAINTY

Where relevant, the following measurement uncertainty levels have been estimated for tests performed on the EUT as specified in CISPR 16-4-2:

MEASUREMENT	FREQUENCY	UNCERTAINTY
Conducted emissions	9kHz~30MHz	2.44 dB
Radiated emissions	30MHz ~ 200MHz	2.93 dB
	200MHz ~1000MHz	2.95 dB
	1GHz ~ 18GHz	2.26 dB
	18GHz ~ 40GHz	1.94 dB

This uncertainty represents an expanded uncertainty expressed at approximately the 95% confidence level using a coverage factor of  $k = 2$ .



### 3. GENERAL INFORMATION

#### 3.1 GENERAL DESCRIPTION OF EUT

<b>EUT</b>	PDA Phone
<b>MODEL NO.</b>	C6750
<b>POWER SUPPLY</b>	5.0Vdc (adapter or host equipment) 3.8Vdc (Li-ion battery)
<b>MODULATION TYPE</b>	CCK, DQPSK, DBPSK for DSSS 64QAM, 16QAM, QPSK, BPSK for OFDM
<b>MODULATION TECHNOLOGY</b>	DSSS, OFDM
<b>TRANSFER RATE</b>	802.11b:11.0/ 5.5/ 2.0/ 1.0Mbps 802.11g: 54.0/ 48.0/ 36.0/ 24.0/ 18.0/ 12.0/ 9.0/ 6.0Mbps 802.11a: 54.0/ 48.0/ 36.0/ 24.0/ 18.0/ 12.0/ 9.0/ 6.0Mbps 802.11n: up to MCS7
<b>OPERATING FREQUENCY</b>	<b>2.4GHz:</b> 2412 ~ 2462MHz <b>5.0GHz:</b> 5745 ~ 5825MHz
<b>NUMBER OF CHANNEL</b>	<b>2.4GHz:</b> 11 for 802.11b, 802.11g, 802.11n (20MHz) <b>5.0GHz:</b> 5 for 802.11a, 802.11n (20MHz) 2 for 802.11n (40MHz)
<b>OUTPUT POWER</b>	162.181mW for 2412 ~ 2462MHz 120.504mW for 5745 ~ 5825MHz
<b>ANTENNA TYPE</b>	<b>2.4GHz:</b> Fixed Internal antenna with -1.5dBi gain <b>5.0GHz:</b> Fixed Internal antenna with -1dBi gain
<b>ANTENNA CONNECTOR</b>	NA
<b>DATA CABLE</b>	Refer to Note as below
<b>I/O PORTS</b>	Refer to user's manual
<b>ACCESSORY DEVICES</b>	Refer to Note as below

**NOTE:**

1. The EUT has following accessories.

No.	Product	Brand	MODEL	Description
1	AC Adapter	Kyocera	SCP-39ADT	I/P: 100-240Vac, 0.2A O/P: 5Vdc, 1A
2	Li-ion Battery	Kyocera	SCP-53LBPS	Rating: 3.8Vdc, 2000mAh
3	USB cable	Kyocera	SCP-14SDC	1.1m shielded cable without core

2. The EUT provides one completed transmitter and one receiver.

MODULATION MODE	TX FUNCTION
802.11b	1TX
802.11g	1TX
802.11a	1TX
802.11n (20MHz)	1TX
802.11n (40MHz)	1TX

3. The above EUT information is declared by the manufacturer and for more detailed features description, please refer to the manufacturer's specifications or User's Manual.

### 3.2 DESCRIPTION OF TEST MODES

#### FOR 2.4GHz:

11 channels are provided for 802.11b, 802.11g and 802.11n (20MHz):

CHANNEL	FREQUENCY	CHANNEL	FREQUENCY
1	2412MHz	7	2442MHz
2	2417MHz	8	2447MHz
3	2422MHz	9	2452MHz
4	2427MHz	10	2457MHz
5	2432MHz	11	2462MHz
6	2437MHz		

#### FOR 5.0GHz:

5 channels are provided for 802.11a, 802.11n (20MHz):

CHANNEL	FREQUENCY	CHANNEL	FREQUENCY
149	5745MHz	161	5805MHz
153	5765MHz	165	5825MHz
157	5785MHz		

2 channels are provided for 802.11n (40MHz):

CHANNEL	FREQUENCY	CHANNEL	FREQUENCY
151	5755MHz	159	5795MHz



### 3.2.1 TEST MODE APPLICABILITY AND TESTED CHANNEL DETAIL

#### FOR 2.4GHz:

EUT CONFIGURE MODE	APPLICABLE TO				DESCRIPTION
	RE $\geq$ 1G	RE<1G	PLC	APCM	
-	√	√	√	√	-

Where **RE $\geq$ 1G**: Radiated Emission above 1GHz      **RE<1G**: Radiated Emission below 1GHz  
**PLC**: Power Line Conducted Emission      **APCM**: Antenna Port Conducted Measurement

**NOTE:** The EUT had been pre-tested on the positioned of each 3 axis. The worst case was found when positioned on **Y-plane**.

#### RADIATED EMISSION TEST (ABOVE 1GHz):

- Pre-Scan has been conducted to determine the worst-case mode from all possible combinations between available modulations, data rates and antenna ports (if EUT with antenna diversity architecture).

MODE	AVAILABLE CHANNEL	TESTED CHANNEL	MODULATION TECHNOLOGY	MODULATION TYPE	DATA RATE (Mbps)
802.11b	1 to 11	1, 6, 11	DSSS	DBPSK	1.0
802.11g	1 to 11	1, 6, 11	OFDM	BPSK	6.0
802.11n (20MHz)	1 to 11	1, 6, 11	OFDM	BPSK	MCS0

#### RADIATED EMISSION TEST (BELOW 1GHz):

- Pre-Scan has been conducted to determine the worst-case mode from all possible combinations between available modulations, data rates and antenna ports (if EUT with antenna diversity architecture).
- Following channel(s) was (were) selected for the final test as listed below.

MODE	AVAILABLE CHANNEL	TESTED CHANNEL	MODULATION TECHNOLOGY	MODULATION TYPE	DATA RATE (Mbps)
802.11g	1 to 11	1	OFDM	BPSK	6.0



**POWER LINE CONDUCTED EMISSION TEST:**

- Pre-Scan has been conducted to determine the worst-case mode from all possible combinations between available modulations, data rates and antenna ports (if EUT with antenna diversity architecture).
- Following channel(s) was (were) selected for the final test as listed below.

MODE	AVAILABLE CHANNEL	TESTED CHANNEL	MODULATION TECHNOLOGY	MODULATION TYPE	DATA RATE (Mbps)
802.11g	1 to 11	1	OFDM	BPSK	6.0

**BANDEDGE MEASUREMENT:**

- Pre-Scan has been conducted to determine the worst-case mode from all possible combinations between available modulations, data rates and antenna ports (if EUT with antenna diversity architecture).
- Following channel(s) was (were) selected for the final test as listed below.

MODE	AVAILABLE CHANNEL	TESTED CHANNEL	MODULATION TECHNOLOGY	MODULATION TYPE	DATA RATE (Mbps)
802.11b	1 to 11	1, 11	DSSS	DBPSK	1.0
802.11g	1 to 11	1, 11	OFDM	BPSK	6.0
802.11n (20MHz)	1 to 11	1, 11	OFDM	BPSK	MCS0

**ANTENNA PORT CONDUCTED MEASUREMENT:**

- This item includes all test value of each mode, but only includes spectrum plot of worst value of each mode.
- Pre-Scan has been conducted to determine the worst-case mode from all possible combinations between available modulations, data rates and antenna ports (if EUT with antenna diversity architecture).
- Following channel(s) was (were) selected for the final test as listed below.

MODE	AVAILABLE CHANNEL	TESTED CHANNEL	MODULATION TECHNOLOGY	MODULATION TYPE	DATA RATE (Mbps)
802.11b	1 to 11	1, 6, 11	DSSS	DBPSK	1.0
802.11g	1 to 11	1, 6, 11	OFDM	BPSK	6.0
802.11n (20MHz)	1 to 11	1, 6, 11	OFDM	BPSK	MCS0

**TEST CONDITION:**

APPLICABLE TO	ENVIRONMENTAL CONDITIONS	INPUT POWER	TESTED BY
RE≥1G	25deg. C, 65%RH	120Vac, 60Hz	Kay Wu
RE<1G	25deg. C, 65%RH	120Vac, 60Hz	Kay Wu
PLC	25deg. C, 65%RH	120Vac, 60Hz	Anson Lin
APCM	25deg. C, 65%RH	120Vac, 60Hz	Howard Kao



**FOR 5.0GHz:**

EUT CONFIGURE MODE	APPLICABLE TO				DESCRIPTION
	RE≥1G	RE<1G	PLC	APCM	
-	√	√	√	√	-

Where **RE≥1G**: Radiated Emission above 1GHz      **RE<1G**: Radiated Emission below 1GHz  
**PLC**: Power Line Conducted Emission      **APCM**: Antenna Port Conducted Measurement

**NOTE:** The EUT had been pre-tested on the positioned of each 3 axis. The worst case was found when positioned on Z-plane.

**RADIATED EMISSION TEST (ABOVE 1GHz):**

- Pre-Scan has been conducted to determine the worst-case mode from all possible combinations between available modulations, data rates and antenna ports (if EUT with antenna diversity architecture).
- Following channel(s) was (were) selected for the final test as listed below.

MODE	AVAILABLE CHANNEL	TESTED CHANNEL	MODULATION TECHNOLOGY	MODULATION TYPE	DATA RATE (Mbps)
802.11a	149 to 165	149, 157, 165	OFDM	BPSK	6.0
802.11n (20MHz)	149 to 165	149, 157, 165	OFDM	BPSK	MCS0
802.11n (40MHz)	151 to 159	151, 159	OFDM	BPSK	MCS0

**RADIATED EMISSION TEST (BELOW 1GHz):**

- Pre-Scan has been conducted to determine the worst-case mode from all possible combinations between available modulations, data rates and antenna ports (if EUT with antenna diversity architecture).
- Following channel(s) was (were) selected for the final test as listed below.

MODE	AVAILABLE CHANNEL	TESTED CHANNEL	MODULATION TECHNOLOGY	MODULATION TYPE	DATA RATE (Mbps)
802.11a	149 to 165	157	OFDM	BPSK	6.0

**POWER LINE CONDUCTED EMISSION TEST:**

- Pre-Scan has been conducted to determine the worst-case mode from all possible combinations between available modulations, data rates and antenna ports (if EUT with antenna diversity architecture).
- Following channel(s) was (were) selected for the final test as listed below.

MODE	AVAILABLE CHANNEL	TESTED CHANNEL	MODULATION TECHNOLOGY	MODULATION TYPE	DATA RATE (Mbps)
802.11a	149 to 165	157	OFDM	BPSK	6.0



**BANDEDGE MEASUREMENT:**

- Pre-Scan has been conducted to determine the worst-case mode from all possible combinations between available modulations, data rates and antenna ports (if EUT with antenna diversity architecture).
- Following channel(s) was (were) selected for the final test as listed below.

MODE	AVAILABLE CHANNEL	TESTED CHANNEL	MODULATION TECHNOLOGY	MODULATION TYPE	DATA RATE (Mbps)
802.11a	149 to 165	149, 157, 165	OFDM	BPSK	6.0
802.11n (20MHz)	149 to 165	149, 157, 165	OFDM	BPSK	MCS0
802.11n (40MHz)	151 to 159	151, 159	OFDM	BPSK	MCS0

**ANTENNA PORT CONDUCTED MEASUREMENT:**

- Pre-Scan has been conducted to determine the worst-case mode from all possible combinations between available modulations, data rates and antenna ports (if EUT with antenna diversity architecture).
- Following channel(s) was (were) selected for the final test as listed below.

MODE	AVAILABLE CHANNEL	TESTED CHANNEL	MODULATION TECHNOLOGY	MODULATION TYPE	DATA RATE (Mbps)
802.11a	149 to 165	149, 157, 165	OFDM	BPSK	6.0
802.11n (20MHz)	149 to 165	149, 157, 165	OFDM	BPSK	MCS0
802.11n (40MHz)	151 to 159	151, 159	OFDM	BPSK	MCS0

**TEST CONDITION:**

APPLICABLE TO	ENVIRONMENTAL CONDITIONS	INPUT POWER	TESTED BY
RE≥1G	25deg. C, 65%RH	120Vac, 60Hz	Kay Wu
RE<1G	25deg. C, 65%RH	120Vac, 60Hz	Kay Wu
PLC	25deg. C, 65%RH	120Vac, 60Hz	Anson Lin
APCM	25deg. C, 65%RH	120Vac, 60Hz	Howard Kao

### 3.3 DESCRIPTION OF SUPPORT UNITS

The EUT has been tested as an independent unit together with other necessary accessories or support units. The following support units or accessories were used to form a representative test configuration during the tests.

NO.	PRODUCT	BRAND	MODEL NO.	SERIAL NO.	FCC ID
1	Earphone	GALIEN	HF-HB04D	NA	NA

NO.	SIGNAL CABLE DESCRIPTION OF THE ABOVE SUPPORT UNITS
1	1.4m non-shielded cable without core.

**NOTE:**

1. All power cords of the above support units are non shielded (1.8m).
2. Item 1 was provided by manufacturer.

#### 3.3.1 CONFIGURATION OF SYSTEM UNDER TEST

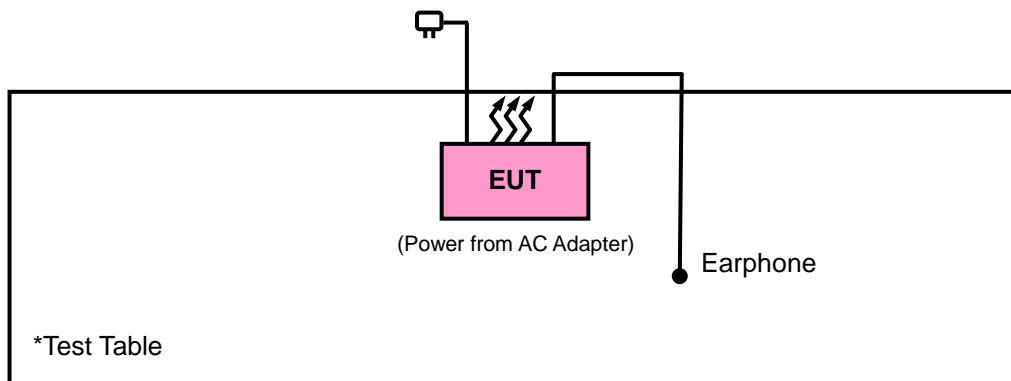

### 3.4 GENERAL DESCRIPTION OF APPLIED STANDARDS

The EUT is a RF Product. According to the specifications of the manufacturer, it must comply with the requirements of the following standards:

**FCC Part 15, Subpart C (15.247)**

ANSI C63.10-2009

KDB 558074 D01 DTS Meas Guidance v02

All test items have been performed and recorded as per the above standards.

**NOTE:** The EUT is also considered as a kind of computer peripheral, because the connection to computer is necessary for typical use. It has been verified to comply with the requirements of FCC Part 15, Subpart B, Class B (DoC). The test report has been issued separately.

## 4. TEST TYPES AND RESULTS (FOR 2.4GHz BAND)

### 4.1 RADIATED EMISSION AND BANDEDGE MEASUREMENT

#### 4.1.1 LIMITS OF RADIATED EMISSION AND BANDEDGE MEASUREMENT

Radiated emissions which fall in the restricted bands must comply with the radiated emission limits specified as below table. Other emissions shall be at least 20dB below the highest level of the desired power:

FREQUENCIES (MHz)	FIELD STRENGTH (microvolts/meter)	MEASUREMENT DISTANCE (meters)
0.009 ~ 0.490	2400/F(kHz)	300
0.490 ~ 1.705	24000/F(kHz)	30
1.705 ~ 30.0	30	30
30 ~ 88	100	3
88 ~ 216	150	3
216 ~ 960	200	3
Above 960	500	3

**NOTE:**

1. The lower limit shall apply at the transition frequencies.
2. Emission level (dBuV/m) = 20 log Emission level (uV/m).
3. For frequencies above 1000MHz, the field strength limits are based on average detector, however, the peak field strength of any emission shall not exceed the maximum permitted average limits, specified above by more than 20dB under any condition of modulation.



#### 4.1.2 TEST INSTRUMENTS

DESCRIPTION & MANUFACTURER	MODEL NO.	SERIAL NO.	DATE OF CALIBRATION	DUE DATE OF CALIBRATION
Test Receiver ROHDE & SCHWARZ	ESCI	100744	Apr. 19, 2012	Apr. 18, 2013
Spectrum Analyzer ROHDE & SCHWARZ	FSU43	101261	Dec. 17, 2012	Dec. 16, 2013
BILOG Antenna SCHWARZBECK	VULB9168	9168-472	Apr. 03, 2012	Apr. 02, 2013
HORN Antenna SCHWARZBECK	BBHA 9120 D	9120D-969	Jan. 07, 2013	Jan. 06, 2014
HORN Antenna SCHWARZBECK	BBHA 9170	9170-480	Dec. 25, 2012	Dec. 24, 2013
Loop Antenna	HFH2-Z2	100070	Jan. 31, 2012	Jan. 30, 2014
Preamplifier EMCI	EMC 012645	980115	Dec. 28, 2012	Dec. 27, 2013
Preamplifier EMCI	EMC 184045	980116	Dec. 28, 2012	Dec. 27, 2013
Preamplifier EMCI	EMC 330H	980112	Dec. 28, 2012	Dec. 27, 2013
RF signal cable HUBER+SUHNNER	SUCOFLEX 104	309219/4	Oct. 19, 2012	Oct. 18, 2013
RF signal cable HUBER+SUHNNER	SUCOFLEX 104	250130/4	Oct. 19, 2012	Oct. 18, 2013
RF signal cable Worken	RG-213	NA	Dec. 29, 2012	Dec. 28, 2013
Software	E3 6.120103	NA	NA	NA
Antenna Tower MF	MFA-440H	NA	NA	NA
Turn Table MF	MFT-201SS	NA	NA	NA
Antenna Tower & Turn Table Controller MF	MF-7802	NA	NA	NA

- NOTE:**
1. The calibration interval of the above test instruments is 12 months and the calibrations are traceable to NML/ROC and NIST/USA.
  2. The calibration interval of the loop antenna is 24 months and the calibrations are traceable to NML/ROC and NIST/USA.
  3. The test was performed in HwaYa Chamber 10.
  4. The horn antenna and HP preamplifier (model: 8449B) are used only for the measurement of emission frequency above 1GHz if tested.
  5. The FCC Site Registration No. is 690701.
  6. The IC Site Registration No. is IC 7450F-10.

#### 4.1.3 TEST PROCEDURES

- a. The EUT was placed on the top of a rotating table 0.8 meters above the ground at a 3 meters semi-anechoic chamber. The table was rotated 360 degrees to determine the position of the highest radiation.
- b. The EUT was set 3 meters away from the interference-receiving antenna, which was mounted on the top of a variable-height antenna tower.
- c. Height of receiving antenna is varied from one meter to four meters above the ground to determine the maximum value of the field strength. Both horizontal and vertical polarizations of the antenna are set to make the measurement.
- d. For each suspected emission, the EUT was arranged to its worst case and then the antenna was tuned to heights from 1 meter to 4 meters and the rotatable table was turned from 0 degrees to 360 degrees to find the maximum reading.
- e. The test-receiver system was set to Peak Detect Function and Specified Bandwidth with Maximum Hold Mode.
- f. If the emission level of the EUT in peak mode was lower than the limit specified, then testing could be stopped and the peak values of the EUT would be reported. Otherwise the emissions would be re-tested one by one using peak, quasi-peak or average method as specified and then reported in a data sheet.

**NOTE:**

1. The resolution bandwidth and video bandwidth of test receiver/spectrum analyzer is 120kHz for Quasi-peak detection at frequency below 1GHz.
2. The resolution bandwidth of test receiver/spectrum analyzer is 1MHz and video bandwidth is 3MHz for Peak detection at frequency above 1GHz.
3. The resolution bandwidth of test receiver/spectrum analyzer is 1MHz and the video bandwidth is 10Hz for Average detection (AV) at frequency above 1GHz.
4. All modes of operation were investigated and the worst-case emissions are reported.

#### 4.1.4 DEVIATION FROM TEST STANDARD

No deviation.



#### 4.1.5 TEST SETUP

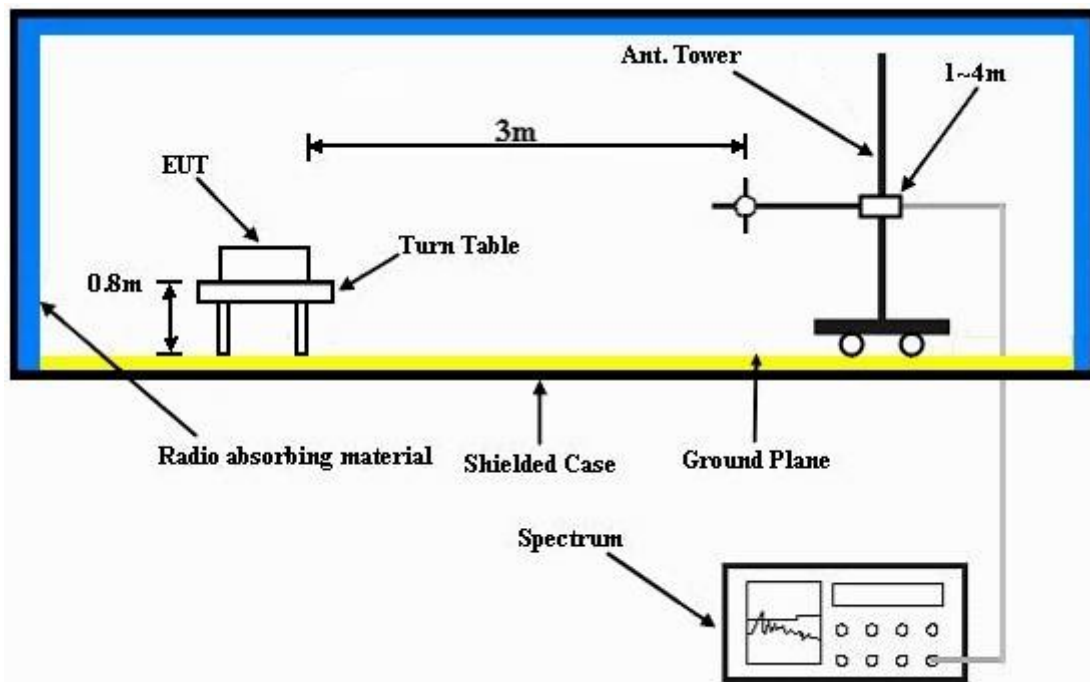

For the actual test configuration, please refer to the attached file (Test Setup Photo).

#### 4.1.6 EUT OPERATING CONDITIONS

- a. Placed the EUT on a testing table.
- b. Use the software to control the EUT under transmission condition continuously at specific channel frequency.



A D T

### 4.1.7 TEST RESULTS

#### ABOVE 1GHz WORST-CASE DATA

##### 802.11b

EUT TEST CONDITION		MEASUREMENT DETAIL	
CHANNEL	Channel 1	FREQUENCY RANGE	1GHz ~ 25GHz
INPUT POWER (SYSTEM)	120Vac, 60 Hz	DETECTOR FUNCTION	Peak (PK) Average (AV)
ENVIRONMENTAL CONDITIONS	25deg. C, 65%RH	TESTED BY	Kay Wu

ANTENNA POLARITY & TEST DISTANCE: HORIZONTAL AT 3 M										
FREQ. (MHz)	EMISSION LEVEL (dBuV/m)	READ LEVEL (dBuV)	LIMIT (dBuV/m)	MARGIN (dB)	ANTENNA FACTOR (dB/m)	CABLE LOSS (dB)	PREAMP FACTOR (dB)	ANTENNA HEIGHT (cm)	TABLE ANGLE (Degree)	REMARK
2390	36.69	42.43	54	-17.31	26.91	4.87	37.52	100	30	Average
2390	51.75	57.49	74	-22.25	26.91	4.87	37.52	100	30	Peak
2412	94.37	100.06			26.96	4.87	37.52	100	30	Average
2412	101.65	107.34			26.96	4.87	37.52	100	30	Peak
2496	36.09	41.2	54	-17.91	27.2	4.94	37.25	100	30	Average
2496	51.75	56.86	74	-22.25	27.2	4.94	37.25	100	30	Peak
ANTENNA POLARITY & TEST DISTANCE: VERTICAL AT 3 M										
FREQ. (MHz)	EMISSION LEVEL (dBuV/m)	READ LEVEL (dBuV)	LIMIT (dBuV/m)	MARGIN (dB)	ANTENNA FACTOR (dB/m)	CABLE LOSS (dB)	PREAMP FACTOR (dB)	ANTENNA HEIGHT (cm)	TABLE ANGLE (Degree)	REMARK
2380	35.7	41.49	54	-18.3	26.86	4.85	37.5	107	254	Average
2380	52.51	58.3	74	-21.49	26.86	4.85	37.5	107	254	Peak
2412	91.38	97.07			26.96	4.87	37.52	107	254	Average
2412	99.53	105.22			26.96	4.87	37.52	107	254	Peak
2496	35.73	40.84	54	-18.27	27.2	4.94	37.25	107	254	Average
2496	52.7	57.81	74	-21.3	27.2	4.94	37.25	107	254	Peak

#### REMARKS:

- 2412MHz: Fundamental frequency.



A D T

EUT TEST CONDITION		MEASUREMENT DETAIL	
CHANNEL	Channel 6	FREQUENCY RANGE	1GHz ~ 25GHz
INPUT POWER (SYSTEM)	120Vac, 60 Hz	DETECTOR FUNCTION	Peak (PK) Average (AV)
ENVIRONMENTAL CONDITIONS	25deg. C, 65%RH	TESTED BY	Kay Wu

ANTENNA POLARITY & TEST DISTANCE: HORIZONTAL AT 3 M										
FREQ. (MHz)	EMISSION LEVEL (dBuV/m)	READ LEVEL (dBuV)	LIMIT (dBuV/m)	MARGIN (dB)	ANTENNA FACTOR (dB/m)	CABLE LOSS (dB)	PREAMP FACTOR (dB)	ANTENNA HEIGHT (cm)	TABLE ANGLE (Degree)	REMARK
2386	37.11	42.85	54	-16.89	26.91	4.85	37.5	102	359	Average
2386	51.36	57.1	74	-22.64	26.91	4.85	37.5	102	359	Peak
2437	95.91	101.42			27.06	4.89	37.46	102	359	Average
2437	103.39	108.9			27.06	4.89	37.46	102	359	Peak
2492	40.79	45.9	54	-13.21	27.2	4.94	37.25	102	359	Average
2492	53.07	58.18	74	-20.93	27.2	4.94	37.25	102	359	Peak
ANTENNA POLARITY & TEST DISTANCE: VERTICAL AT 3 M										
FREQ. (MHz)	EMISSION LEVEL (dBuV/m)	READ LEVEL (dBuV)	LIMIT (dBuV/m)	MARGIN (dB)	ANTENNA FACTOR (dB/m)	CABLE LOSS (dB)	PREAMP FACTOR (dB)	ANTENNA HEIGHT (cm)	TABLE ANGLE (Degree)	REMARK
2374	37.14	5.43	54	-16.86	26.86	4.85	0	105	264	Average
2374	52.2	20.49	74	-21.8	26.86	4.85	0	105	264	Peak
2437	93.19	61.24			27.06	4.89	0	105	264	Average
2437	99.97	68.07			27.01	4.89	0	105	264	Peak
2498	39.31	7.17	54	-14.69	27.2	4.94	0	105	264	Average
2498	51.9	19.76	74	-22.1	27.2	4.94	0	105	264	Peak

**REMARKS:**

- 2437MHz: Fundamental frequency.



A D T

EUT TEST CONDITION		MEASUREMENT DETAIL	
CHANNEL	Channel 11	FREQUENCY RANGE	1GHz ~ 25GHz
INPUT POWER (SYSTEM)	120Vac, 60 Hz	DETECTOR FUNCTION	Peak (PK) Average (AV)
ENVIRONMENTAL CONDITIONS	25deg. C, 65%RH	TESTED BY	Kay Wu

ANTENNA POLARITY & TEST DISTANCE: HORIZONTAL AT 3 M										
FREQ. (MHz)	EMISSION LEVEL (dBuV/m)	READ LEVEL (dBuV)	LIMIT (dBuV/m)	MARGIN (dB)	ANTENNA FACTOR (dB/m)	CABLE LOSS (dB)	PREAMP FACTOR (dB)	ANTENNA HEIGHT (cm)	TABLE ANGLE (Degree)	REMARK
2374	35.43	41.22	54	-18.57	26.86	4.85	37.5	103	358	Average
2374	51.93	57.72	74	-22.07	26.86	4.85	37.5	103	358	Peak
2462	96.65	102.03			27.1	4.91	37.39	103	358	Average
2462	104.6	109.98			27.1	4.91	37.39	103	358	Peak
2486	38.29	43.54	54	-15.71	27.15	4.92	37.32	103	358	Average
2486	52.57	57.82	74	-21.43	27.15	4.92	37.32	103	358	Peak
ANTENNA POLARITY & TEST DISTANCE: VERTICAL AT 3 M										
FREQ. (MHz)	EMISSION LEVEL (dBuV/m)	READ LEVEL (dBuV)	LIMIT (dBuV/m)	MARGIN (dB)	ANTENNA FACTOR (dB/m)	CABLE LOSS (dB)	PREAMP FACTOR (dB)	ANTENNA HEIGHT (cm)	TABLE ANGLE (Degree)	REMARK
2364	35.07	40.93	54	-18.93	26.81	4.82	37.49	106	269	Average
2364	50.88	56.74	74	-23.12	26.81	4.82	37.49	106	269	Peak
2462	94.58	99.96			27.1	4.91	37.39	106	269	Average
2462	102.03	107.41			27.1	4.91	37.39	106	269	Peak
2490	37.62	42.82	54	-16.38	27.2	4.92	37.32	106	269	Average
2490	51.26	56.46	74	-22.74	27.2	4.92	37.32	106	269	Peak

**REMARKS:**

- 2462MHz: Fundamental frequency.



A D T

802.11g

EUT TEST CONDITION		MEASUREMENT DETAIL	
CHANNEL	Channel 1	FREQUENCY RANGE	1GHz ~ 25GHz
INPUT POWER (SYSTEM)	120Vac, 60 Hz	DETECTOR FUNCTION	Peak (PK) Average (AV)
ENVIRONMENTAL CONDITIONS	25deg. C, 65%RH	TESTED BY	Kay Wu

ANTENNA POLARITY & TEST DISTANCE: HORIZONTAL AT 3 M										
FREQ. (MHz)	EMISSION LEVEL (dBuV/m)	READ LEVEL (dBuV)	LIMIT (dBuV/m)	MARGIN (dB)	ANTENNA FACTOR (dB/m)	CABLE LOSS (dB)	PREAMP FACTOR (dB)	ANTENNA HEIGHT (cm)	TABLE ANGLE (Degree)	REMARK
2390	41.33	47.07	54	-12.67	26.91	4.87	37.52	100	358	Average
2390	59.01	64.75	74	-14.99	26.91	4.87	37.52	100	358	Peak
2412	88.53	94.22			26.96	4.87	37.52	100	358	Average
2412	98.39	104.08			26.96	4.87	37.52	100	358	Peak
2486	37.53	42.78	54	-16.47	27.15	4.92	37.32	100	358	Average
2486	52.13	57.38	74	-21.87	27.15	4.92	37.32	100	358	Peak
ANTENNA POLARITY & TEST DISTANCE: VERTICAL AT 3 M										
FREQ. (MHz)	EMISSION LEVEL (dBuV/m)	READ LEVEL (dBuV)	LIMIT (dBuV/m)	MARGIN (dB)	ANTENNA FACTOR (dB/m)	CABLE LOSS (dB)	PREAMP FACTOR (dB)	ANTENNA HEIGHT (cm)	TABLE ANGLE (Degree)	REMARK
2390	38.88	44.62	54	-15.12	26.91	4.87	37.52	107	252	Average
2390	55.28	61.02	74	-18.72	26.91	4.87	37.52	107	252	Peak
2412	85.41	91.1			26.96	4.87	37.52	107	252	Average
2412	94.94	100.63			26.96	4.87	37.52	107	252	Peak
2484	37.07	42.32	54	-16.93	27.15	4.92	37.32	107	252	Average
2484	51.11	56.36	74	-22.89	27.15	4.92	37.32	107	252	Peak

REMARKS:

- 2412MHz: Fundamental frequency.



A D T

EUT TEST CONDITION		MEASUREMENT DETAIL	
CHANNEL	Channel 6	FREQUENCY RANGE	1GHz ~ 25GHz
INPUT POWER (SYSTEM)	120Vac, 60 Hz	DETECTOR FUNCTION	Peak (PK) Average (AV)
ENVIRONMENTAL CONDITIONS	25deg. C, 65%RH	TESTED BY	Kay Wu

ANTENNA POLARITY & TEST DISTANCE: HORIZONTAL AT 3 M										
FREQ. (MHz)	EMISSION LEVEL (dBuV/m)	READ LEVEL (dBuV)	LIMIT (dBuV/m)	MARGIN (dB)	ANTENNA FACTOR (dB/m)	CABLE LOSS (dB)	PREAMP FACTOR (dB)	ANTENNA HEIGHT (cm)	TABLE ANGLE (Degree)	REMARK
2384	39.49	45.28	54	-14.51	26.86	4.85	37.5	102	359	Average
2384	52.43	58.22	74	-21.57	26.86	4.85	37.5	102	359	Peak
2437	90.67	96.18			27.06	4.89	37.46	102	359	Average
2437	101.54	107.05			27.06	4.89	37.46	102	359	Peak
2490	42.31	47.51	54	-11.69	27.2	4.92	37.32	102	359	Average
2490	53.44	58.64	74	-20.56	27.2	4.92	37.32	102	359	Peak

ANTENNA POLARITY & TEST DISTANCE: VERTICAL AT 3 M										
FREQ. (MHz)	EMISSION LEVEL (dBuV/m)	READ LEVEL (dBuV)	LIMIT (dBuV/m)	MARGIN (dB)	ANTENNA FACTOR (dB/m)	CABLE LOSS (dB)	PREAMP FACTOR (dB)	ANTENNA HEIGHT (cm)	TABLE ANGLE (Degree)	REMARK
2332	37.1	43.06	54	-16.9	26.72	4.79	37.47	104	251	Average
2332	51.31	57.27	74	-22.69	26.72	4.79	37.47	104	251	Peak
2437	85.01	90.52			27.06	4.89	37.46	104	251	Average
2437	94.35	99.86			27.06	4.89	37.46	104	251	Peak
2488	39.17	44.37	54	-14.83	27.2	4.92	37.32	104	251	Average
2488	52.1	57.3	74	-21.9	27.2	4.92	37.32	104	251	Peak

**REMARKS:**

1. 2437MHz: Fundamental frequency.



A D T

EUT TEST CONDITION		MEASUREMENT DETAIL	
CHANNEL	Channel 11	FREQUENCY RANGE	1GHz ~ 25GHz
INPUT POWER (SYSTEM)	120Vac, 60 Hz	DETECTOR FUNCTION	Peak (PK) Average (AV)
ENVIRONMENTAL CONDITIONS	25deg. C, 65%RH	TESTED BY	Kay Wu

ANTENNA POLARITY & TEST DISTANCE: HORIZONTAL AT 3 M										
FREQ. (MHz)	EMISSION LEVEL (dBuV/m)	READ LEVEL (dBuV)	LIMIT (dBuV/m)	MARGIN (dB)	ANTENNA FACTOR (dB/m)	CABLE LOSS (dB)	PREAMP FACTOR (dB)	ANTENNA HEIGHT (cm)	TABLE ANGLE (Degree)	REMARK
2346	36.21	42.11	54	-17.79	26.77	4.82	37.49	101	359	Average
2346	51.3	57.2	74	-22.7	26.77	4.82	37.49	101	359	Peak
2462	89.64	95.02			27.1	4.91	37.39	101	359	Average
2462	99.01	104.39			27.1	4.91	37.39	101	359	Peak
2484	42.17	47.42	54	-11.83	27.15	4.92	37.32	101	359	Average
2484	56.35	61.6	74	-17.65	27.15	4.92	37.32	101	359	Peak

ANTENNA POLARITY & TEST DISTANCE: VERTICAL AT 3 M										
FREQ. (MHz)	EMISSION LEVEL (dBuV/m)	READ LEVEL (dBuV)	LIMIT (dBuV/m)	MARGIN (dB)	ANTENNA FACTOR (dB/m)	CABLE LOSS (dB)	PREAMP FACTOR (dB)	ANTENNA HEIGHT (cm)	TABLE ANGLE (Degree)	REMARK
2362	36.34	42.2	54	-17.66	26.81	4.82	37.49	102	246	Average
2362	51.43	57.29	74	-22.57	26.81	4.82	37.49	102	246	Peak
2462	84.7	90.08			27.1	4.91	37.39	102	246	Average
2462	94.91	100.29			27.1	4.91	37.39	102	246	Peak
2484	39.54	44.79	54	-14.46	27.15	4.92	37.32	102	246	Average
2484	52.82	58.07	74	-21.18	27.15	4.92	37.32	102	246	Peak

**REMARKS:**

- 1. 2462MHz: Fundamental frequency.



A D T

802.11n (20MHz)

EUT TEST CONDITION		MEASUREMENT DETAIL	
CHANNEL	Channel 1	FREQUENCY RANGE	1GHz ~ 25GHz
INPUT POWER (SYSTEM)	120Vac, 60 Hz	DETECTOR FUNCTION	Peak (PK) Average (AV)
ENVIRONMENTAL CONDITIONS	25deg. C, 65%RH	TESTED BY	Kay Wu

ANTENNA POLARITY & TEST DISTANCE: HORIZONTAL AT 3 M										
FREQ. (MHz)	EMISSION LEVEL (dBuV/m)	READ LEVEL (dBuV)	LIMIT (dBuV/m)	MARGIN (dB)	ANTENNA FACTOR (dB/m)	CABLE LOSS (dB)	PREAMP FACTOR (dB)	ANTENNA HEIGHT (cm)	TABLE ANGLE (Degree)	REMARK
2388	42.08	47.82	54	-11.92	26.91	4.85	37.5	100	9	Average
2388	64.95	70.69	74	-9.05	26.91	4.85	37.5	100	9	Peak
2412	89.02	94.71			26.96	4.87	37.52	100	9	Average
2412	99.45	105.14			26.96	4.87	37.52	100	9	Peak
2498	37.11	42.22	54	-16.89	27.2	4.94	37.25	100	9	Average
2498	52.65	57.76	74	-21.35	27.2	4.94	37.25	100	9	Peak
ANTENNA POLARITY & TEST DISTANCE: VERTICAL AT 3 M										
FREQ. (MHz)	EMISSION LEVEL (dBuV/m)	READ LEVEL (dBuV)	LIMIT (dBuV/m)	MARGIN (dB)	ANTENNA FACTOR (dB/m)	CABLE LOSS (dB)	PREAMP FACTOR (dB)	ANTENNA HEIGHT (cm)	TABLE ANGLE (Degree)	REMARK
2390	39.59	45.33	54	-14.41	26.91	4.87	37.52	105	248	Average
2390	63.77	69.51	74	-10.23	26.91	4.87	37.52	105	248	Peak
2412	85.12	90.81			26.96	4.87	37.52	105	248	Average
2412	95.42	101.11			26.96	4.87	37.52	105	248	Peak
2494	35.81	40.92	54	-18.19	27.2	4.94	37.25	105	248	Average
2494	52.18	57.29	74	-21.82	27.2	4.94	37.25	105	248	Peak

REMARKS:

- 2412MHz: Fundamental frequency.





A D T

EUT TEST CONDITION		MEASUREMENT DETAIL	
CHANNEL	Channel 6	FREQUENCY RANGE	1GHz ~ 25GHz
INPUT POWER (SYSTEM)	120Vac, 60 Hz	DETECTOR FUNCTION	Peak (PK) Average (AV)
ENVIRONMENTAL CONDITIONS	25deg. C, 65%RH	TESTED BY	Kay Wu

ANTENNA POLARITY & TEST DISTANCE: HORIZONTAL AT 3 M										
FREQ. (MHz)	EMISSION LEVEL (dBuV/m)	READ LEVEL (dBuV)	LIMIT (dBuV/m)	MARGIN (dB)	ANTENNA FACTOR (dB/m)	CABLE LOSS (dB)	PREAMP FACTOR (dB)	ANTENNA HEIGHT (cm)	TABLE ANGLE (Degree)	REMARK
2386	39.3	45.04	54	-14.7	26.91	4.85	37.5	100	12	Average
2386	52.58	58.32	74	-21.42	26.91	4.85	37.5	100	12	Peak
2437	90.22	95.73			27.06	4.89	37.46	100	12	Average
2437	100.56	106.07			27.06	4.89	37.46	100	12	Peak
2488	42.46	47.66	54	-11.54	27.2	4.92	37.32	100	12	Average
2488	53.88	59.08	74	-20.12	27.2	4.92	37.32	100	12	Peak
ANTENNA POLARITY & TEST DISTANCE: VERTICAL AT 3 M										
FREQ. (MHz)	EMISSION LEVEL (dBuV/m)	READ LEVEL (dBuV)	LIMIT (dBuV/m)	MARGIN (dB)	ANTENNA FACTOR (dB/m)	CABLE LOSS (dB)	PREAMP FACTOR (dB)	ANTENNA HEIGHT (cm)	TABLE ANGLE (Degree)	REMARK
2384	36.32	42.11	54	-17.68	26.86	4.85	37.5	130	247	Average
2384	52.3	58.09	74	-21.7	26.86	4.85	37.5	130	247	Peak
2437	83.83	89.34			27.06	4.89	37.46	130	247	Average
2437	94.76	100.27			27.06	4.89	37.46	130	247	Peak
2490	37.14	42.34	54	-16.86	27.2	4.92	37.32	130	247	Average
2490	51.96	57.16	74	-22.04	27.2	4.92	37.32	130	247	Peak

**REMARKS:**

1. 2437MHz: Fundamental frequency.



A D T

EUT TEST CONDITION		MEASUREMENT DETAIL	
CHANNEL	Channel 11	FREQUENCY RANGE	1GHz ~ 25GHz
INPUT POWER (SYSTEM)	120Vac, 60 Hz	DETECTOR FUNCTION	Peak (PK) Average (AV)
ENVIRONMENTAL CONDITIONS	25deg. C, 65%RH	TESTED BY	Kay Wu

ANTENNA POLARITY & TEST DISTANCE: HORIZONTAL AT 3 M										
FREQ. (MHz)	EMISSION LEVEL (dBuV/m)	READ LEVEL (dBuV)	LIMIT (dBuV/m)	MARGIN (dB)	ANTENNA FACTOR (dB/m)	CABLE LOSS (dB)	PREAMP FACTOR (dB)	ANTENNA HEIGHT (cm)	TABLE ANGLE (Degree)	REMARK
2360	35.31	41.17	54	-18.69	26.81	4.82	37.49	100	9	Average
2360	51.72	57.58	74	-22.28	26.81	4.82	37.49	100	9	Peak
2462	89.11	94.49			27.1	4.91	37.39	100	9	Average
2462	99.06	104.44			27.1	4.91	37.39	100	9	Peak
2484	41.98	47.23	54	-12.02	27.15	4.92	37.32	100	9	Average
2484	60.65	65.9	74	-13.35	27.15	4.92	37.32	100	9	Peak
ANTENNA POLARITY & TEST DISTANCE: VERTICAL AT 3 M										
FREQ. (MHz)	EMISSION LEVEL (dBuV/m)	READ LEVEL (dBuV)	LIMIT (dBuV/m)	MARGIN (dB)	ANTENNA FACTOR (dB/m)	CABLE LOSS (dB)	PREAMP FACTOR (dB)	ANTENNA HEIGHT (cm)	TABLE ANGLE (Degree)	REMARK
2372	34.82	40.61	54	-19.18	26.86	4.85	37.5	103	246	Average
2372	51.86	57.65	74	-22.14	26.86	4.85	37.5	103	246	Peak
2462	83.51	88.89			27.1	4.91	37.39	103	246	Average
2462	94.52	99.9			27.1	4.91	37.39	103	246	Peak
2484	38.34	43.59	54	-15.66	27.15	4.92	37.32	103	246	Average
2484	55.42	60.67	74	-18.58	27.15	4.92	37.32	103	246	Peak

**REMARKS:**

- 2462MHz: Fundamental frequency.



A D T

**BELOW 1GHz WORST-CASE DATA: 802.11g**

EUT TEST CONDITION		MEASUREMENT DETAIL	
CHANNEL	Channel 1	FREQUENCY RANGE	30MHz ~ 1GHz
INPUT POWER (SYSTEM)	120Vac, 60 Hz	DETECTOR FUNCTION	Peak (PK) Average (AV)
ENVIRONMENTAL CONDITIONS	25deg. C, 65%RH	TESTED BY	Kay Wu

**ANTENNA POLARITY & TEST DISTANCE: HORIZONTAL AT 3 M**

FREQ. (MHz)	EMISSION LEVEL (dBuV/m)	READ LEVEL (dBuV)	LIMIT (dBuV/m)	MARGIN (dB)	ANTENNA FACTOR (dB/m)	CABLE LOSS (dB)	PREAMP FACTOR (dB)	ANTENNA HEIGHT (cm)	TABLE ANGLE (Degree)	REMARK
43.5	18.16	34.97	40	-21.84	13.59	0.71	31.11	114	152	Peak
160.14	16.45	34.21	43.5	-27.05	12.73	1.39	31.88	109	248	Peak
254.37	16.53	34.99	46	-29.47	11.59	1.85	31.9	113	34	Peak
374.2	22.58	37.46	46	-23.42	14.73	2.32	31.93	107	90	Peak
596.1	25.04	34.65	46	-20.96	19.52	3.08	32.21	107	178	Peak
801.9	27.88	33.36	46	-18.12	22.25	3.7	31.43	120	180	Peak

**ANTENNA POLARITY & TEST DISTANCE: VERTICAL AT 3 M**

FREQ. (MHz)	EMISSION LEVEL (dBuV/m)	READ LEVEL (dBuV)	LIMIT (dBuV/m)	MARGIN (dB)	ANTENNA FACTOR (dB/m)	CABLE LOSS (dB)	PREAMP FACTOR (dB)	ANTENNA HEIGHT (cm)	TABLE ANGLE (Degree)	REMARK
60.78	20.57	39.33	40	-19.43	11.82	0.83	31.41	102	288	Peak
154.47	15.53	33.17	43.5	-27.97	12.72	1.36	31.72	101	112	Peak
240.6	15.34	34.27	46	-30.66	11.07	1.79	31.79	115	301	Peak
398.7	20.07	34.46	46	-25.93	15.31	2.42	32.12	106	79	Peak
617.8	25.2	34.39	46	-20.8	19.82	3.14	32.15	105	88	Peak
771.8	27.64	33.51	46	-18.36	21.83	3.63	31.33	104	221	Peak

## 4.2 CONDUCTED EMISSION MEASUREMENT

### 4.2.1 LIMITS OF CONDUCTED EMISSION MEASUREMENT

FREQUENCY OF EMISSION (MHz)	CONDUCTED LIMIT (dB $\mu$ V)	
	Quasi-peak	Average
0.15 ~ 0.5	66 to 56	56 to 46
0.5 ~ 5	56	46
5 ~ 30	60	50

- NOTE:** 1. The lower limit shall apply at the transition frequencies.
2. The limit decreases in line with the logarithm of the frequency in the range of 0.15 to 0.50MHz.
3. All emanations from a class A/B digital device or system, including any network of conductors and apparatus connected thereto, shall not exceed the level of field strengths specified above.

### 4.2.2 TEST INSTRUMENTS

DESCRIPTION & MANUFACTURER	MODEL NO.	SERIAL NO.	DATE OF CALIBRATION	DUE DATE OF CALIBRATION
Test Receiver ROHDE & SCHWARZ	ESCS30	100288	Nov. 09, 2012	Nov. 08, 2013
RF signal cable Woken	5D-FB	Cable-HYCO2-01	Dec. 28, 2012	Dec. 27, 2013
LISN ROHDE & SCHWARZ (EUT)	ESH2-Z5	100100	Dec. 21, 2012	Dec. 20, 2013
LISN ROHDE & SCHWARZ (Peripheral)	ESH3-Z5	100311	Jul. 06, 2012	Jul. 05, 2013
Software ADT	BV ADT_Cond_ V7.3.7.3	NA	NA	NA

- NOTE:** 1. The calibration interval of the above test instruments is 12 months and the calibrations are traceable to NML/ROC and NIST/USA.
2. The test was performed in HwaYa Shielded Room 2.
3. The VCCI Site Registration No. is C-2047.

#### 4.2.3 TEST PROCEDURES

- a. The EUT was placed 0.4 meters from the conducting wall of the shielded room with EUT being connected to the power mains through a line impedance stabilization network (LISN). Other support units were connected to the power mains through another LISN. The two LISNs provide 50 ohm/ 50uH of coupling impedance for the measuring instrument.
- b. Both lines of the power mains connected to the EUT were checked for maximum conducted interference.
- c. The frequency range from 150kHz to 30MHz was searched. Emission levels under (Limit - 20dB) was not recorded.

**NOTE:** All modes of operation were investigated and the worst-case emissions are reported.

#### 4.2.4 DEVIATION FROM TEST STANDARD

No deviation.

#### 4.2.5 TEST SETUP

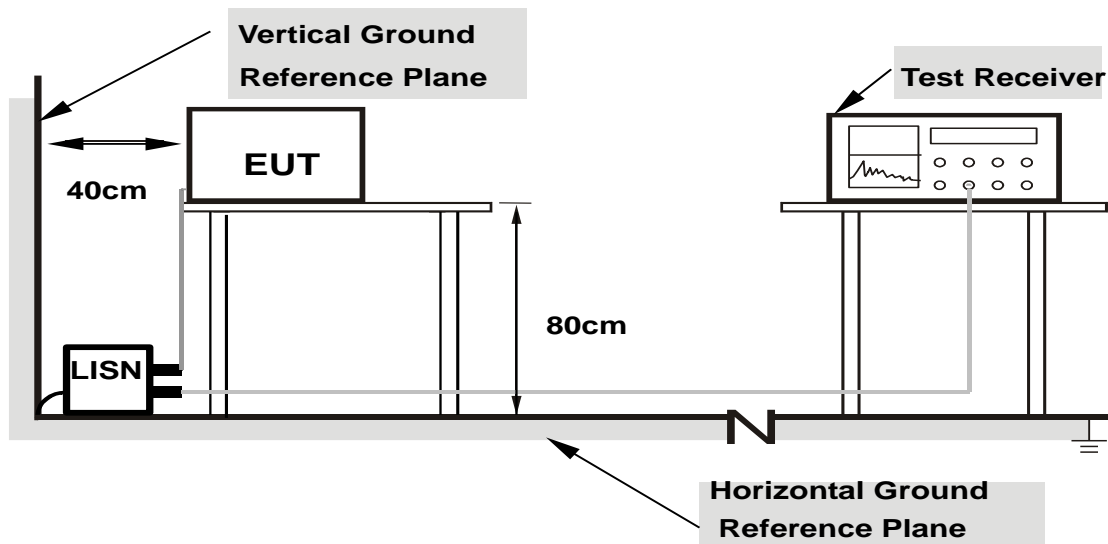

- Note:**
1. Support units were connected to second LISN.
  2. Both of LISNs (AMN) are 80 cm from EUT and at least 80 from other units and other metal planes

For the actual test configuration, please refer to the attached file (Test Setup Photo).

#### 4.2.6 EUT OPERATING CONDITIONS

Same as 4.1.6.

### 4.2.7 TEST RESULTS

#### CONDUCTED WORST-CASE DATA : 802.11g

PHASE	Line 1	6dB BANDWIDTH	9kHz
-------	--------	---------------	------

No	Freq. [MHz]	Corr. Factor (dB)	Reading Value [dB (uV)]		Emission Level [dB (uV)]		Limit [dB (uV)]		Margin (dB)	
			Q.P.	AV.	Q.P.	AV.	Q.P.	AV.	Q.P.	AV.
			1	0.15781	0.12	52.65	44.25	52.77	44.37	65.58
2	0.47422	0.16	44.76	34.44	44.92	34.60	56.44	46.44	-11.52	-11.84
3	0.88828	0.20	44.22	33.11	44.42	33.31	56.00	46.00	-11.58	-12.69
4	1.62891	0.22	41.27	33.18	41.49	33.40	56.00	46.00	-14.51	-12.60
5	13.55859	0.86	56.28	54.25	57.14	55.11	60.00	50.00	-2.86	5.11
6	24.11328	1.36	33.73	23.26	35.09	24.62	60.00	50.00	-24.91	-25.38

#### REMARKS:

1. Q.P. and AV. are abbreviations of quasi-peak and average individually.
2. The emission levels of other frequencies were very low against the limit.
3. Margin value = Emission level - Limit value
4. Correction factor = Insertion loss + Cable loss
5. Emission Level = Correction Factor + Reading Value.
6. No. 5 is NFC signal inductive with measurement system. Please check P35-36 to see test result for EUT with a suitable dummy load.

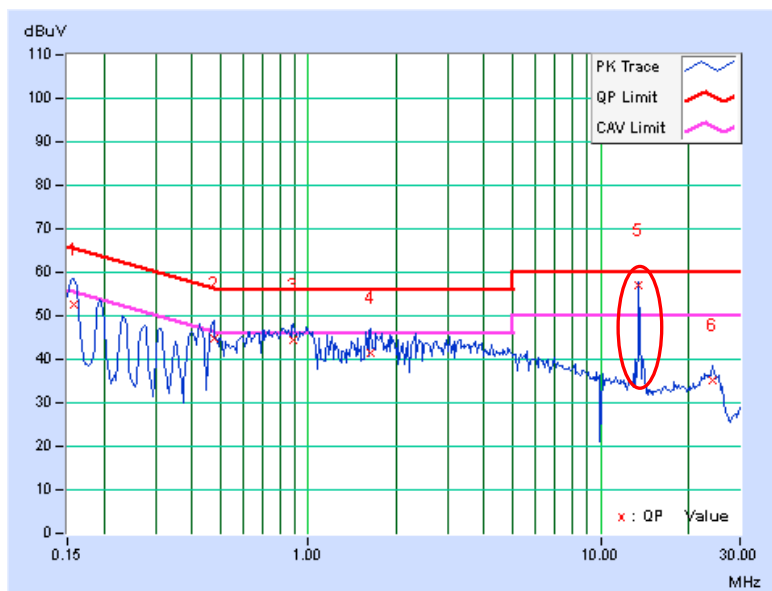

PHASE	Line 2	6dB BANDWIDTH	9kHz
-------	--------	---------------	------

No	Freq. [MHz]	Corr. Factor (dB)	Reading Value [dB (uV)]		Emission Level [dB (uV)]		Limit [dB (uV)]		Margin (dB)	
			Q.P.	AV.	Q.P.	AV.	Q.P.	AV.	Q.P.	AV.
			1	0.15781	0.17	46.50	37.84	46.67	38.01	65.58
2	0.39219	0.21	40.63	28.82	40.84	29.03	58.02	48.02	-17.18	-18.99
3	0.81406	0.24	37.89	29.02	38.13	29.26	56.00	46.00	-17.87	-16.74
4	2.11719	0.29	36.00	27.00	36.29	27.29	56.00	46.00	-19.71	-18.71
5	13.55859	0.71	54.47	51.79	55.18	52.50	60.00	50.00	-4.82	2.50
6	23.87891	1.02	32.37	20.81	33.39	21.83	60.00	50.00	-26.61	-28.17

**REMARKS:**

1. Q.P. and AV. are abbreviations of quasi-peak and average individually.
2. The emission levels of other frequencies were very low against the limit.
3. Margin value = Emission level - Limit value
4. Correction factor = Insertion loss + Cable loss
5. Emission Level = Correction Factor + Reading Value.
6. No. 5 is NFC signal inductive with measurement system. Please check P35-36 to see test result for EUT with a suitable dummy load.

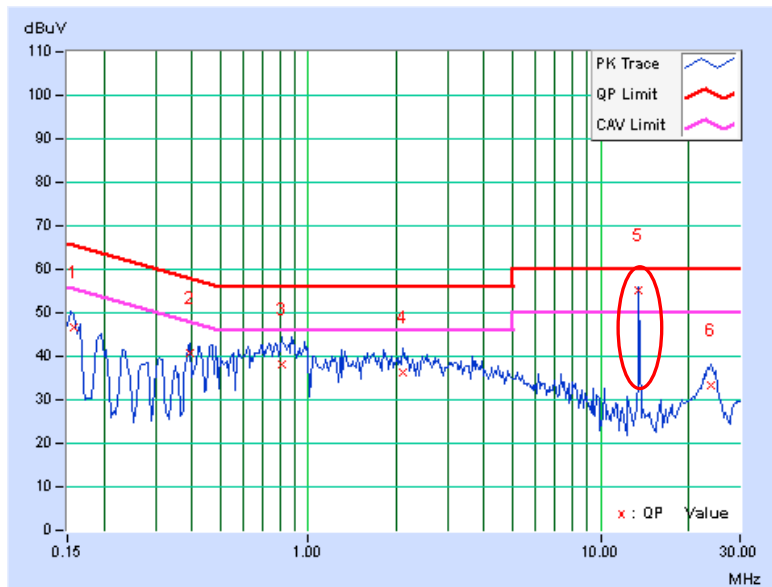



### Test with suitable dummy load

PHASE	Line 1	6dB BANDWIDTH	9kHz
-------	--------	---------------	------

No	Freq. [MHz]	Corr. Factor (dB)	Reading Value [dB (uV)]		Emission Level [dB (uV)]		Limit [dB (uV)]		Margin (dB)	
			Q.P.	AV.	Q.P.	AV.	Q.P.	AV.	Q.P.	AV.
			1	0.15391	0.12	46.65	37.79	46.77	37.91	65.79
2	0.46250	0.16	40.04	30.90	40.20	31.06	56.65	46.65	-16.45	-15.59
3	0.88438	0.20	39.68	29.79	39.88	29.99	56.00	46.00	-16.12	-16.01
4	2.49219	0.26	38.58	29.89	38.84	30.15	56.00	46.00	-17.16	-15.85
5	6.79688	0.49	34.03	24.03	34.52	24.52	60.00	50.00	-25.48	-25.48
6	18.04688	1.12	26.76	16.61	27.88	17.73	60.00	50.00	-32.12	-32.27

**REMARKS:**

1. Q.P. and AV. are abbreviations of quasi-peak and average individually.
2. The emission levels of other frequencies were very low against the limit.
3. Margin value = Emission level - Limit value
4. Correction factor = Insertion loss + Cable loss
5. Emission Level = Correction Factor + Reading Value.

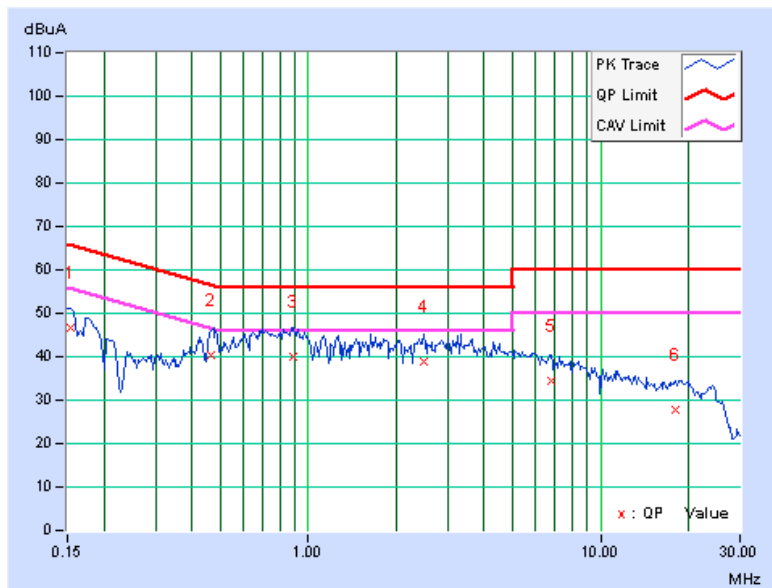

<b>PHASE</b>	Line 2	<b>6dB BANDWIDTH</b>	9kHz
--------------	--------	----------------------	------

No	Freq.	Corr. Factor	Reading Value		Emission Level		Limit		Margin	
	[MHz]		[dB (uV)]		[dB (uV)]		[dB (uV)]		(dB)	
			Q.P.	AV.	Q.P.	AV.	Q.P.	AV.	Q.P.	AV.
1	0.15000	0.18	44.74	35.49	44.92	35.67	66.00	56.00	-21.08	-20.33
2	0.47031	0.21	43.04	36.26	43.25	36.47	56.51	46.51	-13.25	-10.03
3	0.96641	0.25	38.28	29.76	38.53	30.01	56.00	46.00	-17.47	-15.99
4	1.44531	0.26	36.91	28.23	37.17	28.49	56.00	46.00	-18.83	-17.51
5	9.46484	0.57	25.38	17.58	25.95	18.15	60.00	50.00	-34.05	-31.85
6	24.05859	1.02	29.80	18.52	30.82	19.54	60.00	50.00	-29.18	-30.46

**REMARKS:**

1. Q.P. and AV. are abbreviations of quasi-peak and average individually.
2. The emission levels of other frequencies were very low against the limit.
3. Margin value = Emission level - Limit value
4. Correction factor = Insertion loss + Cable loss
5. Emission Level = Correction Factor + Reading Value.

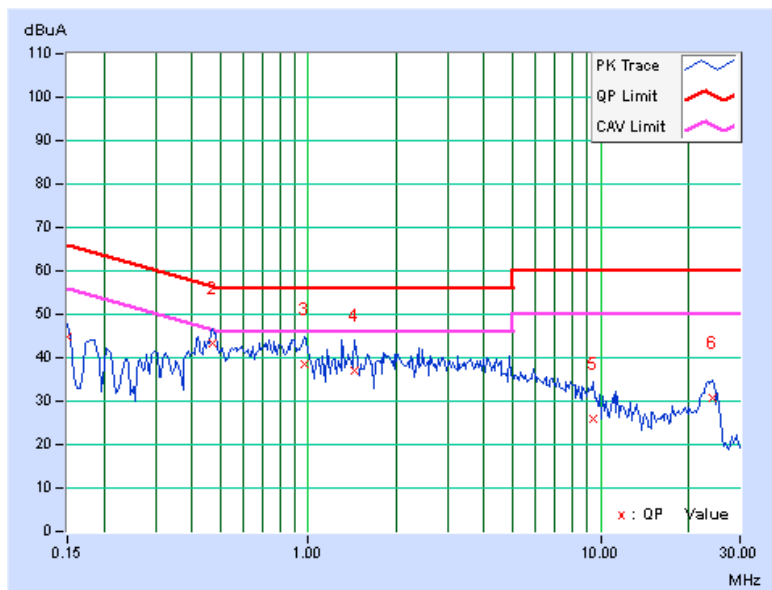

### 4.3 6dB BANDWIDTH MEASUREMENT

#### 4.3.1 LIMITS OF 6dB BANDWIDTH MEASUREMENT

The minimum of 6dB Bandwidth Measurement is 0.5 MHz.

#### 4.3.2 TEST SETUP

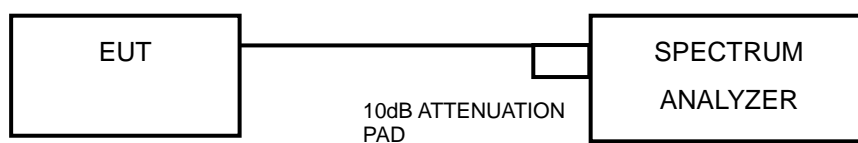

#### 4.3.3 TEST INSTRUMENTS

Refer to section 4.1.2 to get information of above instrument.

#### 4.3.4 TEST PROCEDURE

- a. Set resolution bandwidth (RBW) = approximately 1% of the emission bandwidth
- b. Set the video bandwidth (VBW)  $\geq 3 \times$  RBW, Detector = Peak.
- c. Trace mode = max hold.
- d. Sweep = auto couple.
- e. Measure the maximum width of the emission that is constrained by the frequencies associated with the two amplitude points (upper and lower) that are attenuated by 6 dB relative to the maximum level measured in the fundamental emission

#### 4.3.5 DEVIATION FROM TEST STANDARD

No deviation.

#### 4.3.6 EUT OPERATING CONDITIONS

The software provided by client to enable the EUT under transmission condition continuously at lowest, middle and highest channel frequencies individually.



A D T

#### 4.3.7 TEST RESULTS

##### 802.11b

CHANNEL	FREQUENCY (MHz)	6dB BANDWIDTH (MHz)	MINIMUM LIMIT (MHz)	PASS / FAIL
1	2412	8.99	0.5	PASS
6	2437	8.50	0.5	PASS
11	2462	7.86	0.5	PASS

##### 802.11g

CHANNEL	FREQUENCY (MHz)	6dB BANDWIDTH (MHz)	MINIMUM LIMIT (MHz)	PASS / FAIL
1	2412	16.49	0.5	PASS
6	2437	16.50	0.5	PASS
11	2462	16.49	0.5	PASS

##### 802.11n (20MHz)

CHANNEL	FREQUENCY (MHz)	6dB BANDWIDTH (MHz)	MINIMUM LIMIT (MHz)	PASS / FAIL
1	2412	17.60	0.5	PASS
6	2437	17.64	0.5	PASS
11	2462	17.64	0.5	PASS

## 4.4 CONDUCTED OUTPUT POWER

### 4.4.1 LIMITS OF CONDUCTED OUTPUT POWER MEASUREMENT

For systems using digital modulation in the 2400–2483.5 MHz bands: 1 Watt (30dBm)

### 4.4.2 TEST SETUP

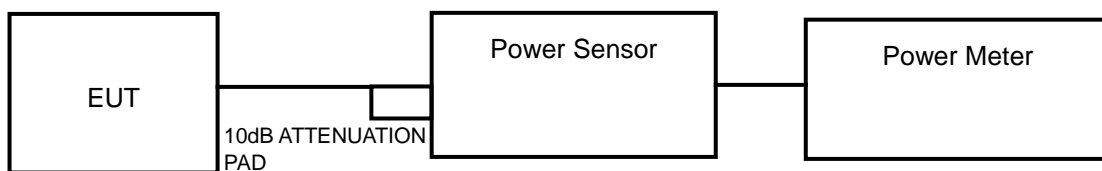

or

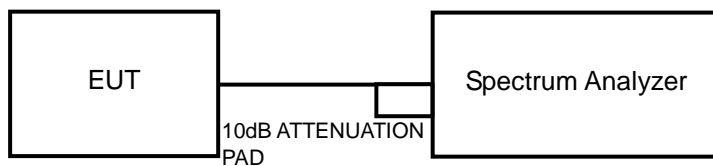

#### 4.4.3 TEST INSTRUMENTS

Refer to section 4.1.2 to get information of above instrument.

#### 4.4.4 TEST PROCEDURES

A peak power sensor was used on the output port of the EUT. A power meter or spectrum analyzer was used to read the response of the peak power sensor. Record the peak power level.

#### 4.4.5 DEVIATION FROM TEST STANDARD

No deviation.

#### 4.4.6 EUT OPERATING CONDITIONS

Same as Item 4.3.6.



A D T

#### 4.4.7 TEST RESULTS

##### 802.11b

CHANNEL	FREQUENCY (MHz)	PEAK POWER (mW)	PEAK POWER (dBm)	LIMIT (dBm)	PASS/FAIL
1	2412	100.462	20.02	30	PASS
6	2437	89.950	19.54	30	PASS
11	2462	84.333	19.26	30	PASS

##### 802.11g

CHANNEL	FREQUENCY (MHz)	PEAK POWER (mW)	PEAK POWER (dBm)	LIMIT (dBm)	PASS/FAIL
1	2412	162.181	22.1	30	PASS
6	2437	160.694	22.06	30	PASS
11	2462	142.889	21.55	30	PASS

##### 802.11n (20MHz)

CHANNEL	FREQUENCY (MHz)	PEAK POWER (mW)	PEAK POWER (dBm)	LIMIT (dBm)	PASS/FAIL
1	2412	160.694	22.06	30	PASS
6	2437	157.398	21.97	30	PASS
11	2462	135.207	21.31	30	PASS

## 4.5 POWER SPECTRAL DENSITY MEASUREMENT

### 4.5.1 LIMITS OF POWER SPECTRAL DENSITY MEASUREMENT

The Maximum of Power Spectral Density Measurement is 8dBm.

### 4.5.2 TEST SETUP

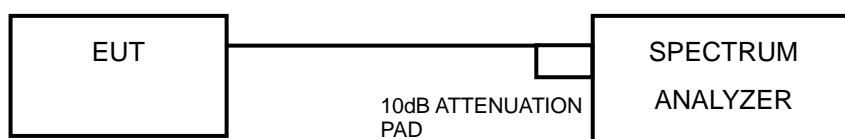

### 4.5.3 TEST INSTRUMENTS

Refer to section 4.1.2 to get information of above instrument.

### 4.5.4 TEST PROCEDURE

- a. Set the RBW = 3 kHz, VBW = 10 kHz, Detector = peak.
- b. Sweep time = auto couple, Trace mode = max hold, allow trace to fully stabilize.
- c. Use the peak marker function to determine the maximum power level in any 100 kHz band segment within the fundamental EBW.

### 4.5.5 DEVIATION FROM TEST STANDARD

No deviation.

### 4.5.6 EUT OPERATING CONDITION

Same as Item 4.3.6





A D T

## 4.5.7 TEST RESULTS

### 802.11b

Channel	FREQ. (MHz)	PSD (dBm/3kHz)	Limit (dBm/3kHz)	PASS /FAIL
1	2412	-6.38	8	PASS
6	2437	-6.50	8	PASS
11	2462	-6.19	8	PASS

### 802.11g

Channel	FREQ. (MHz)	PSD (dBm/3kHz)	Limit (dBm/3kHz)	PASS /FAIL
1	2412	-11.43	8	PASS
6	2437	-11.81	8	PASS
11	2462	-13.03	8	PASS

### 802.11n (20MHz)

Channel	FREQ. (MHz)	PSD (dBm/3kHz)	Limit (dBm/3kHz)	PASS /FAIL
1	2412	-12.33	8	PASS
6	2437	-11.84	8	PASS
11	2462	-13.50	8	PASS

## 4.6 CONDUCTED OUT OF BAND EMISSION MEASUREMENT

### 4.6.1 LIMITS OF CONDUCTED OUT OF BAND EMISSION MEASUREMENT

Below  $-20\text{dB}$  of the highest emission level of operating band (in 100kHz Resolution Bandwidth).

### 4.6.2 TEST SETUP

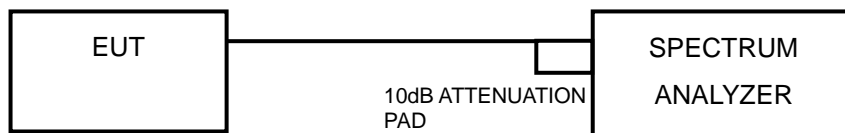

### 4.6.3 TEST INSTRUMENTS

Refer to section 4.1.2 to get information of above instrument.

### 4.6.4 TEST PROCEDURE

#### MEASUREMENT PROCEDURE REF

1. Set the RBW = 100 kHz.
2. Set the VBW  $\geq$  300 kHz.
3. Detector = peak.
4. Sweep time = auto couple.
5. Trace mode = max hold.
6. Allow trace to fully stabilize.
7. Use the peak marker function to determine the maximum power level in any 100 kHz band segment within the fundamental EBW.



A D T

## MEASUREMENT PROCEDURE OOB

1. Set RBW = 100 kHz.
2. Set VBW  $\geq$  300 kHz.
3. Set span to encompass the spectrum to be examined.
4. Detector = peak.
5. Trace Mode = max hold.
6. Sweep = auto couple.

### 4.6.5 DEVIATION FROM TEST STANDARD

No deviation.

### 4.6.6 EUT OPERATING CONDITION

Same as Item 4.3.6

### 4.6.7 TEST RESULTS

The spectrum plots are attached on the following pages. D1 line indicates the highest level, and D2 line indicates the 20dB offset below D1. It shows compliance with the requirement.



A D T

### 802.11b

#### CH 1

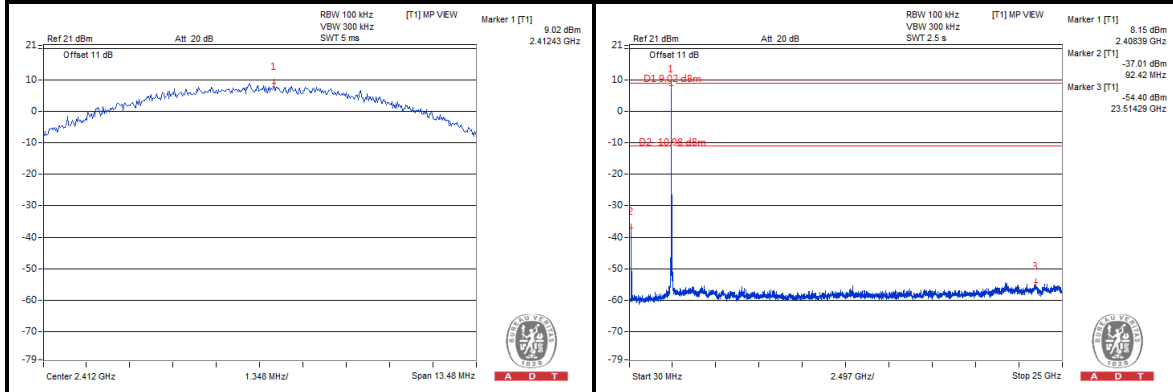

#### CH 6

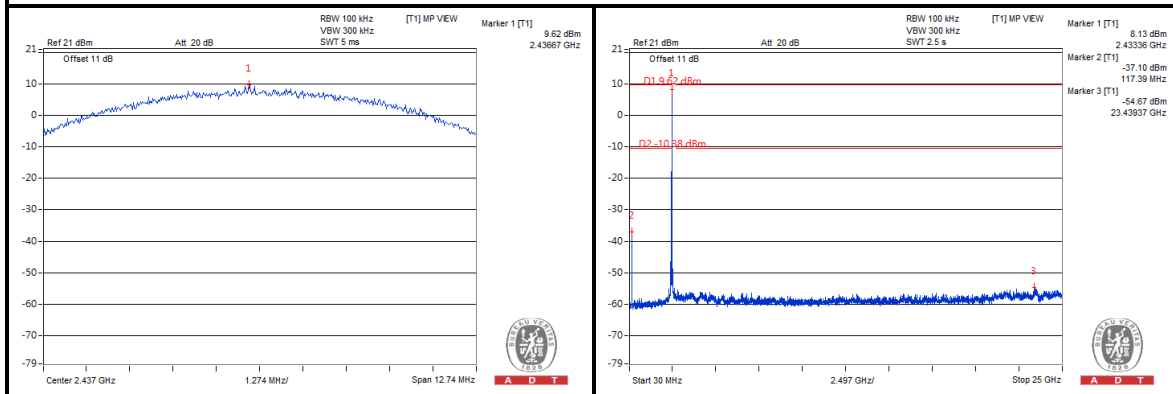

#### CH 11

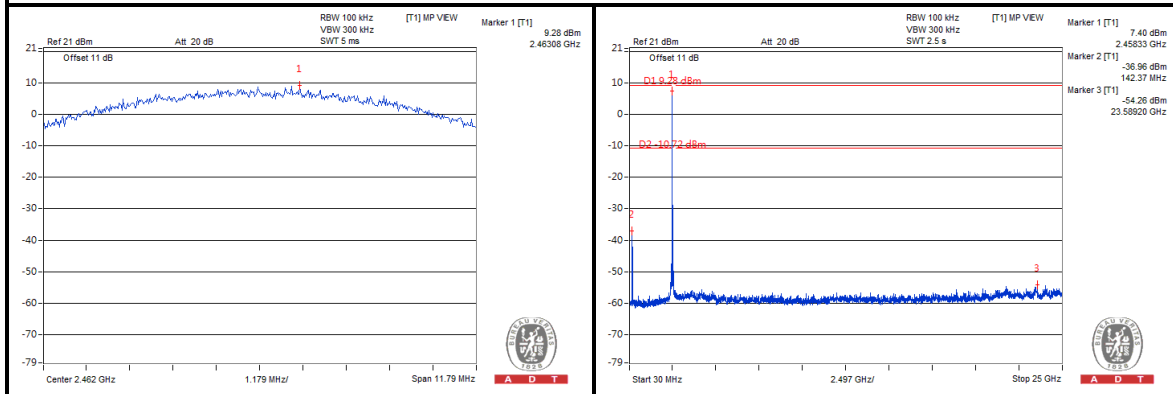



A D T

### 802.11g

#### CH 1

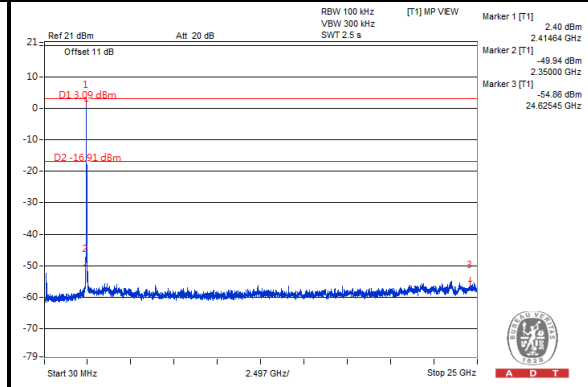
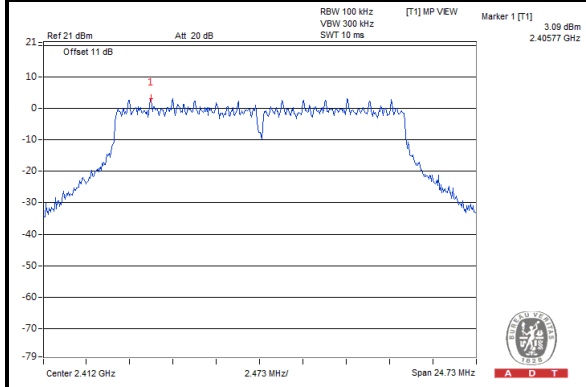

#### CH 6

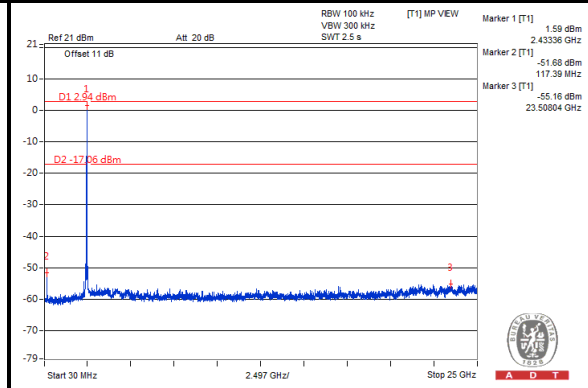
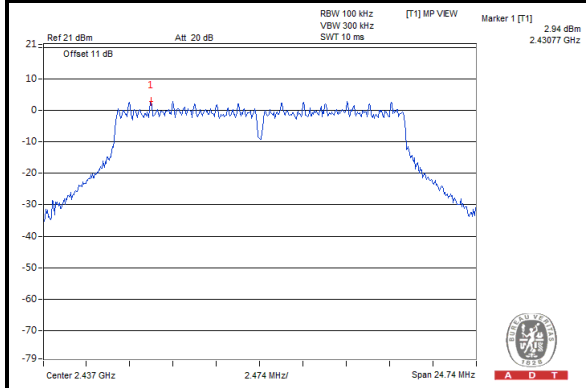

#### CH 11

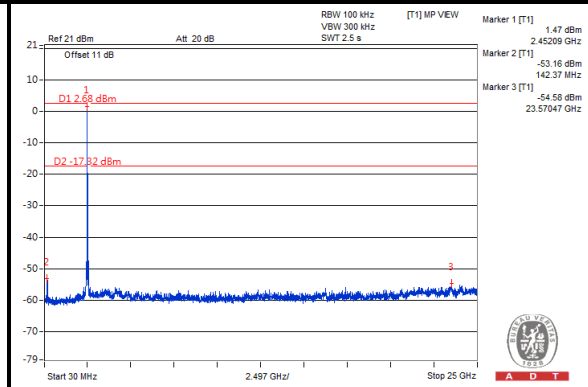
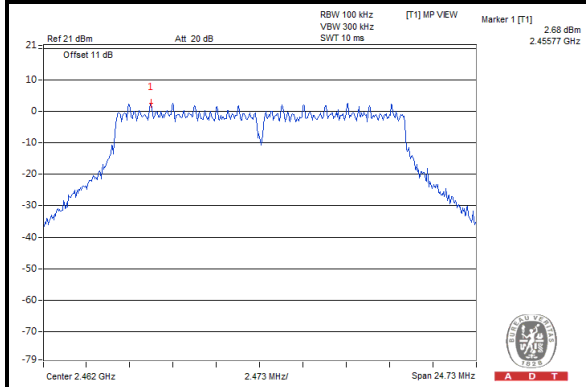



A D T

### 802.11n (20MHz)

#### CH 1

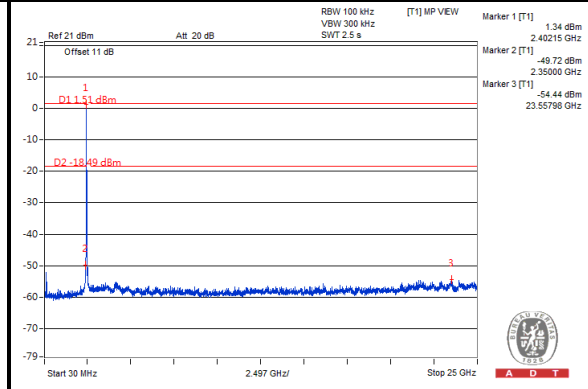
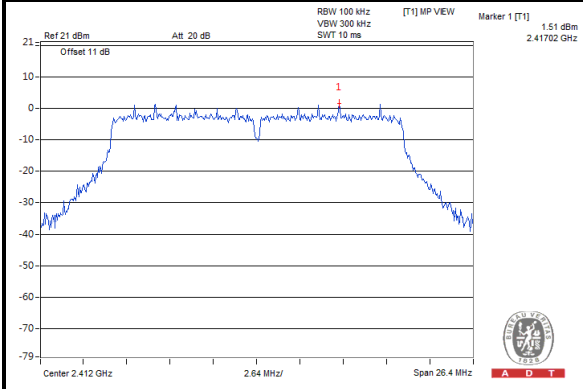

#### CH 6

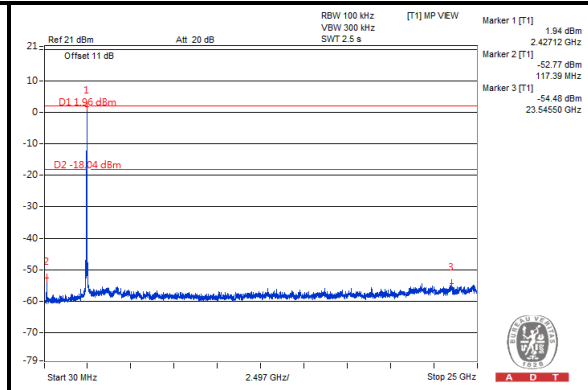
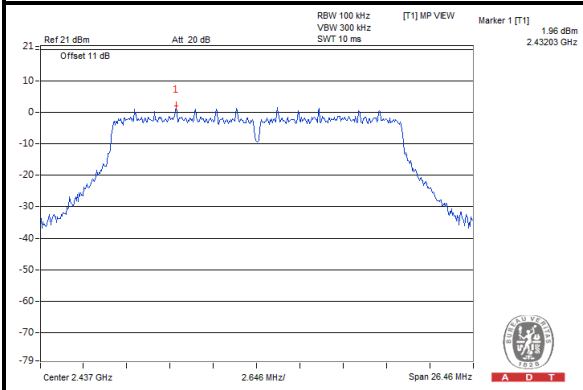

#### CH 11

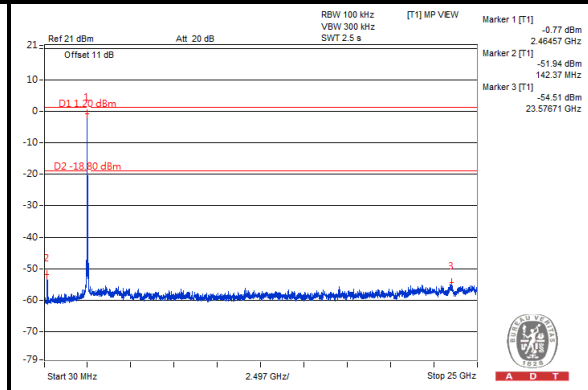
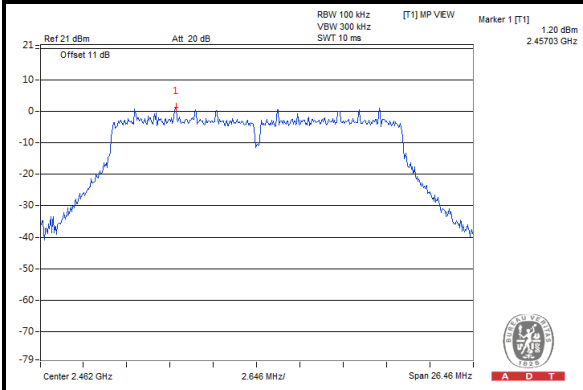

## 5. TEST TYPES AND RESULTS (FOR 5.0GHz BAND)

### 5.1 RADIATED EMISSION AND BANDEDGE MEASUREMENT

#### 5.1.1 LIMITS OF RADIATED EMISSION AND BANDEDGE MEASUREMENT

Radiated emissions which fall in the restricted bands must comply with the radiated emission limits specified as below table. Other emissions shall be at least 20dB below the highest level of the desired power:

FREQUENCIES (MHz)	FIELD STRENGTH (microvolts/meter)	MEASUREMENT DISTANCE (meters)
0.009 ~ 0.490	2400/F(kHz)	300
0.490 ~ 1.705	24000/F(kHz)	30
1.705 ~ 30.0	30	30
30 ~ 88	100	3
88 ~ 216	150	3
216 ~ 960	200	3
Above 960	500	3

**NOTE:**

1. The lower limit shall apply at the transition frequencies.
2. Emission level (dBuV/m) = 20 log Emission level (uV/m).
3. For frequencies above 1000MHz, the field strength limits are based on average detector, however, the peak field strength of any emission shall not exceed the maximum permitted average limits, specified above by more than 20dB under any condition of modulation.



A D T

### 5.1.2 TEST INSTRUMENTS

Same as item 4.1.2.

### 5.1.3 TEST PROCEDURES

Same as item 4.1.3.

### 5.1.4 DEVIATION FROM TEST STANDARD

No deviation.

### 5.1.5 TEST SETUP

Same as item 4.1.5.

### 5.1.6 EUT OPERATING CONDITIONS

Same as 4.1.6.





### 5.1.7 TEST RESULTS

#### ABOVE 1GHz WORST-CASE DATA

##### 802.11a

EUT TEST CONDITION		MEASUREMENT DETAIL	
CHANNEL	Channel 149	FREQUENCY RANGE	1GHz ~ 40GHz
INPUT POWER (SYSTEM)	120Vac, 60 Hz	DETECTOR FUNCTION	Peak (PK) Average (AV)
ENVIRONMENTAL CONDITIONS	25deg. C, 65%RH	TESTED BY	Kay Wu

ANTENNA POLARITY & TEST DISTANCE: HORIZONTAL AT 3 M										
FREQ. (MHz)	EMISSION LEVEL (dBuV/m)	READ LEVEL (dBuV)	LIMIT (dBuV/m)	MARGIN (dB)	ANTENNA FACTOR (dB/m)	CABLE LOSS (dB)	PREAMP FACTOR (dB)	ANTENNA HEIGHT (cm)	TABLE ANGLE (Degree)	REMARK
5725	43.24	41	63.25	-20.01	31.96	7.71	37.43	110	50	Average
5725	56.8	54.56	73.04	-16.24	31.96	7.71	37.43	110	50	Peak
5745	83.25	80.99			31.99	7.74	37.47	110	50	Average
5745	93.04	90.78			31.99	7.74	37.47	110	50	Peak
5850	40.57	38.1	63.25	-22.68	32.15	7.83	37.51	110	50	Average
5850	56.35	53.88	73.04	-16.69	32.15	7.83	37.51	110	50	Peak

ANTENNA POLARITY & TEST DISTANCE: VERTICAL AT 3 M										
FREQ. (MHz)	EMISSION LEVEL (dBuV/m)	READ LEVEL (dBuV)	LIMIT (dBuV/m)	MARGIN (dB)	ANTENNA FACTOR (dB/m)	CABLE LOSS (dB)	PREAMP FACTOR (dB)	ANTENNA HEIGHT (cm)	TABLE ANGLE (Degree)	REMARK
5725	50	47.76	71.74	-21.74	31.96	7.71	37.43	113	307	Average
5725	63.68	61.44	81.35	-17.67	31.96	7.71	37.43	113	307	Peak
5745	91.74	89.48			31.99	7.74	37.47	113	307	Average
5745	101.35	99.09			31.99	7.74	37.47	113	307	Peak
5850	40.45	37.98	71.74	-31.29	32.15	7.83	37.51	113	307	Average
5850	54.83	52.36	81.35	-26.52	32.15	7.83	37.51	113	307	Peak

#### REMARKS:

- 5745MHz: Fundamental frequency.
- 5725MHz & 5850MHz: Out of restricted band



A D T

EUT TEST CONDITION		MEASUREMENT DETAIL	
CHANNEL	Channel 157	FREQUENCY RANGE	1GHz ~ 40GHz
INPUT POWER (SYSTEM)	120Vac, 60 Hz	DETECTOR FUNCTION	Peak (PK) Average (AV)
ENVIRONMENTAL CONDITIONS	25deg. C, 65%RH	TESTED BY	Kay Wu

ANTENNA POLARITY & TEST DISTANCE: HORIZONTAL AT 3 M										
FREQ. (MHz)	EMISSION LEVEL (dBuV/m)	READ LEVEL (dBuV)	LIMIT (dBuV/m)	MARGIN (dB)	ANTENNA FACTOR (dB/m)	CABLE LOSS (dB)	PREAMP FACTOR (dB)	ANTENNA HEIGHT (cm)	TABLE ANGLE (Degree)	REMARK
5725	40.51	38.27	65.32	-24.81	31.96	7.71	37.43	111	48	Average
5725	54.6	52.36	74.67	-20.07	31.96	7.71	37.43	111	48	Peak
5785	85.32	83.02			32.04	7.8	37.54	111	48	Average
5785	94.67	92.37			32.04	7.8	37.54	111	48	Peak
5850	40.55	38.08	65.32	-24.77	32.15	7.83	37.51	111	48	Average
5850	55.08	52.61	74.67	-19.59	32.15	7.83	37.51	111	48	Peak
ANTENNA POLARITY & TEST DISTANCE: VERTICAL AT 3 M										
FREQ. (MHz)	EMISSION LEVEL (dBuV/m)	READ LEVEL (dBuV)	LIMIT (dBuV/m)	MARGIN (dB)	ANTENNA FACTOR (dB/m)	CABLE LOSS (dB)	PREAMP FACTOR (dB)	ANTENNA HEIGHT (cm)	TABLE ANGLE (Degree)	REMARK
5725	42.63	40.39	72.78	-30.15	31.96	7.71	37.43	124	307	Average
5725	55.54	53.3	82.53	-26.99	31.96	7.71	37.43	124	307	Peak
5785	92.78	90.48			32.04	7.8	37.54	124	307	Average
5785	102.53	100.23			32.04	7.8	37.54	124	307	Peak
5850	40.7	38.23	72.78	-32.08	32.15	7.83	37.51	124	307	Average
5850	56.26	53.79	82.53	-26.27	32.15	7.83	37.51	124	307	Peak

**REMARKS:**

- 5785MHz: Fundamental frequency.
- 5725MHz & 5850MHz: Out of restricted band



A D T

EUT TEST CONDITION		MEASUREMENT DETAIL	
CHANNEL	Channel 165	FREQUENCY RANGE	1GHz ~ 40GHz
INPUT POWER (SYSTEM)	120Vac, 60 Hz	DETECTOR FUNCTION	Peak (PK) Average (AV)
ENVIRONMENTAL CONDITIONS	25deg. C, 65%RH	TESTED BY	Kay Wu

ANTENNA POLARITY & TEST DISTANCE: HORIZONTAL AT 3 M										
FREQ. (MHz)	EMISSION LEVEL (dBuV/m)	READ LEVEL (dBuV)	LIMIT (dBuV/m)	MARGIN (dB)	ANTENNA FACTOR (dB/m)	CABLE LOSS (dB)	PREAMP FACTOR (dB)	ANTENNA HEIGHT (cm)	TABLE ANGLE (Degree)	REMARK
5725	44.24	42	64.68	-20.44	31.96	7.71	37.43	100	20	Average
5725	55.03	52.79	74.42	-19.39	31.96	7.71	37.43	100	20	Peak
5825	84.68	82.27			32.12	7.82	37.53	100	20	Average
5825	94.42	92.01			32.12	7.82	37.53	100	20	Peak
5850	45.06	42.59	64.68	-19.62	32.15	7.83	37.51	100	20	Average
5850	56.69	54.22	74.42	-17.73	32.15	7.83	37.51	100	20	Peak
ANTENNA POLARITY & TEST DISTANCE: VERTICAL AT 3 M										
FREQ. (MHz)	EMISSION LEVEL (dBuV/m)	READ LEVEL (dBuV)	LIMIT (dBuV/m)	MARGIN (dB)	ANTENNA FACTOR (dB/m)	CABLE LOSS (dB)	PREAMP FACTOR (dB)	ANTENNA HEIGHT (cm)	TABLE ANGLE (Degree)	REMARK
5725	40.35	38.11	73.41	-33.06	31.96	7.71	37.43	112	305	Average
5725	54.62	52.38	82.97	-28.35	31.96	7.71	37.43	112	305	Peak
5825	93.41	91			32.12	7.82	37.53	112	305	Average
5825	102.97	100.56			32.12	7.82	37.53	112	305	Peak
5850	44.7	42.23	73.41	-28.71	32.15	7.83	37.51	112	305	Average
5850	59.47	57	82.97	-23.5	32.15	7.83	37.51	112	305	Peak

**REMARKS:**

- 5825MHz: Fundamental frequency.
- 5725MHz & 5850MHz: Out of restricted band



A D T

802.11n (20MHz)

EUT TEST CONDITION		MEASUREMENT DETAIL	
CHANNEL	Channel 149	FREQUENCY RANGE	1GHz ~ 40GHz
INPUT POWER (SYSTEM)	120Vac, 60 Hz	DETECTOR FUNCTION	Peak (PK) Average (AV)
ENVIRONMENTAL CONDITIONS	25deg. C, 65%RH	TESTED BY	Kay Wu

ANTENNA POLARITY & TEST DISTANCE: HORIZONTAL AT 3 M										
FREQ. (MHz)	EMISSION LEVEL (dBuV/m)	READ LEVEL (dBuV)	LIMIT (dBuV/m)	MARGIN (dB)	ANTENNA FACTOR (dB/m)	CABLE LOSS (dB)	PREAMP FACTOR (dB)	ANTENNA HEIGHT (cm)	TABLE ANGLE (Degree)	REMARK
5725	44.11	41.87	61.96	-17.85	31.96	7.71	37.43	100	323	Average
5725	57.67	55.43	72.14	-14.47	31.96	7.71	37.43	100	323	Peak
5745	81.96	79.7			31.99	7.74	37.47	100	323	Average
5745	92.14	89.88			31.99	7.74	37.47	100	323	Peak
5850	40.38	37.91	61.96	-21.58	32.15	7.83	37.51	100	323	Average
5850	57.09	54.62	72.14	-15.05	32.15	7.83	37.51	100	323	Peak
ANTENNA POLARITY & TEST DISTANCE: VERTICAL AT 3 M										
FREQ. (MHz)	EMISSION LEVEL (dBuV/m)	READ LEVEL (dBuV)	LIMIT (dBuV/m)	MARGIN (dB)	ANTENNA FACTOR (dB/m)	CABLE LOSS (dB)	PREAMP FACTOR (dB)	ANTENNA HEIGHT (cm)	TABLE ANGLE (Degree)	REMARK
5725	49.31	47.07	69.56	-20.25	31.96	7.71	37.43	100	293	Average
5725	65.44	63.2	79.29	-13.85	31.96	7.71	37.43	100	293	Peak
5745	89.56	87.3			31.99	7.74	37.47	100	293	Average
5745	99.29	97.03			31.99	7.74	37.47	100	293	Peak
5850	40.49	38.02	69.56	-29.07	32.15	7.83	37.51	100	293	Average
5850	54.8	52.33	79.29	-24.49	32.15	7.83	37.51	100	293	Peak

REMARKS:

- 5745MHz: Fundamental frequency.
- 5725MHz & 5850MHz: Out of restricted band



A D T

EUT TEST CONDITION		MEASUREMENT DETAIL	
CHANNEL	Channel 157	FREQUENCY RANGE	1GHz ~ 40GHz
INPUT POWER (SYSTEM)	120Vac, 60 Hz	DETECTOR FUNCTION	Peak (PK) Average (AV)
ENVIRONMENTAL CONDITIONS	25deg. C, 65%RH	TESTED BY	Kay Wu

ANTENNA POLARITY & TEST DISTANCE: HORIZONTAL AT 3 M										
FREQ. (MHz)	EMISSION LEVEL (dBuV/m)	READ LEVEL (dBuV)	LIMIT (dBuV/m)	MARGIN (dB)	ANTENNA FACTOR (dB/m)	CABLE LOSS (dB)	PREAMP FACTOR (dB)	ANTENNA HEIGHT (cm)	TABLE ANGLE (Degree)	REMARK
5725	40.49	38.25	61.62	-21.13	31.96	7.71	37.43	100	322	Average
5725	56.22	53.98	72.24	-16.02	31.96	7.71	37.43	100	322	Peak
5785	81.62	79.32			32.04	7.8	37.54	100	322	Average
5785	92.24	89.94			32.04	7.8	37.54	100	322	Peak
5850	40.36	37.89	61.62	-21.26	32.15	7.83	37.51	100	322	Average
5850	55.09	52.62	72.24	-17.15	32.15	7.83	37.51	100	322	Peak
ANTENNA POLARITY & TEST DISTANCE: VERTICAL AT 3 M										
FREQ. (MHz)	EMISSION LEVEL (dBuV/m)	READ LEVEL (dBuV)	LIMIT (dBuV/m)	MARGIN (dB)	ANTENNA FACTOR (dB/m)	CABLE LOSS (dB)	PREAMP FACTOR (dB)	ANTENNA HEIGHT (cm)	TABLE ANGLE (Degree)	REMARK
5725	42.08	39.84	70.93	-28.85	31.96	7.71	37.43	100	307	Average
5725	55.24	53	80.47	-25.23	31.96	7.71	37.43	100	307	Peak
5785	90.93	88.63			32.04	7.8	37.54	100	307	Average
5785	100.47	98.17			32.04	7.8	37.54	100	307	Peak
5850	40.58	38.11	70.93	-30.35	32.15	7.83	37.51	100	307	Average
5850	56.54	54.07	80.47	-23.93	32.15	7.83	37.51	100	307	Peak

**REMARKS:**

- 5785MHz: Fundamental frequency.
- 5725MHz & 5850MHz: Out of restricted band



A D T

EUT TEST CONDITION		MEASUREMENT DETAIL	
CHANNEL	Channel 165	FREQUENCY RANGE	1GHz ~ 40GHz
INPUT POWER (SYSTEM)	120Vac, 60 Hz	DETECTOR FUNCTION	Peak (PK) Average (AV)
ENVIRONMENTAL CONDITIONS	25deg. C, 65%RH	TESTED BY	Kay Wu

ANTENNA POLARITY & TEST DISTANCE: HORIZONTAL AT 3 M										
FREQ. (MHz)	EMISSION LEVEL (dBuV/m)	READ LEVEL (dBuV)	LIMIT (dBuV/m)	MARGIN (dB)	ANTENNA FACTOR (dB/m)	CABLE LOSS (dB)	PREAMP FACTOR (dB)	ANTENNA HEIGHT (cm)	TABLE ANGLE (Degree)	REMARK
5725	40.15	37.91	63.46	-23.31	31.96	7.71	37.43	100	7	Average
5725	54.87	52.63	72.98	-18.11	31.96	7.71	37.43	100	7	Peak
5825	83.46	81.05			32.12	7.82	37.53	100	7	Average
5825	92.98	90.57			32.12	7.82	37.53	100	7	Peak
5850	42.04	39.57	63.46	-21.42	32.15	7.83	37.51	100	7	Average
5850	56.81	54.34	72.98	-16.17	32.15	7.83	37.51	100	7	Peak
ANTENNA POLARITY & TEST DISTANCE: VERTICAL AT 3 M										
FREQ. (MHz)	EMISSION LEVEL (dBuV/m)	READ LEVEL (dBuV)	LIMIT (dBuV/m)	MARGIN (dB)	ANTENNA FACTOR (dB/m)	CABLE LOSS (dB)	PREAMP FACTOR (dB)	ANTENNA HEIGHT (cm)	TABLE ANGLE (Degree)	REMARK
5725	40.46	38.22	70.99	-30.53	31.96	7.71	37.43	100	308	Average
5725	55.2	52.96	80.46	-25.26	31.96	7.71	37.43	100	308	Peak
5825	90.99	88.58			32.12	7.82	37.53	100	308	Average
5825	100.46	98.05			32.12	7.82	37.53	100	308	Peak
5850	44.69	42.22	70.99	-26.3	32.15	7.83	37.51	100	308	Average
5850	60.64	58.17	80.46	-19.82	32.15	7.83	37.51	100	308	Peak

**REMARKS:**

- 5825MHz: Fundamental frequency.
- 5725MHz & 5850MHz: Out of restricted band



## 802.11n (40MHz)

EUT TEST CONDITION		MEASUREMENT DETAIL	
CHANNEL	Channel 151	FREQUENCY RANGE	1GHz ~ 40GHz
INPUT POWER (SYSTEM)	120Vac, 60 Hz	DETECTOR FUNCTION	Peak (PK) Average (AV)
ENVIRONMENTAL CONDITIONS	25deg. C, 65%RH	TESTED BY	Kay Wu

ANTENNA POLARITY & TEST DISTANCE: HORIZONTAL AT 3 M										
FREQ. (MHz)	EMISSION LEVEL (dBuV/m)	READ LEVEL (dBuV)	LIMIT (dBuV/m)	MARGIN (dB)	ANTENNA FACTOR (dB/m)	CABLE LOSS (dB)	PREAMP FACTOR (dB)	ANTENNA HEIGHT (cm)	TABLE ANGLE (Degree)	REMARK
5725	45.07	42.83	60.42	-15.35	31.96	7.71	37.43	100	322	Average
5725	57.99	55.75	69.77	-11.78	31.96	7.71	37.43	100	322	Peak
5755	80.42	78.14			32.01	7.74	37.47	100	322	Average
5755	89.77	87.49			32.01	7.74	37.47	100	322	Peak
5850	40.53	38.06	60.42	-19.89	32.15	7.83	37.51	100	322	Average
5850	56.1	53.63	69.77	-13.67	32.15	7.83	37.51	100	322	Peak
ANTENNA POLARITY & TEST DISTANCE: VERTICAL AT 3 M										
FREQ. (MHz)	EMISSION LEVEL (dBuV/m)	READ LEVEL (dBuV)	LIMIT (dBuV/m)	MARGIN (dB)	ANTENNA FACTOR (dB/m)	CABLE LOSS (dB)	PREAMP FACTOR (dB)	ANTENNA HEIGHT (cm)	TABLE ANGLE (Degree)	REMARK
5725	51.69	49.45	68.97	-17.28	31.96	7.71	37.43	114	305	Average
5725	66.75	64.51	78.47	-11.72	31.96	7.71	37.43	114	305	Peak
5755	88.97	86.69			32.01	7.74	37.47	114	305	Average
5755	98.47	96.19			32.01	7.74	37.47	114	305	Peak
5850	40.74	38.27	68.97	-28.23	32.15	7.83	37.51	114	305	Average
5850	56.39	53.92	78.47	-22.08	32.15	7.83	37.51	114	305	Peak

## REMARKS:

- 5755MHz: Fundamental frequency.
- 5725MHz & 5850MHz: Out of restricted band



A D T

EUT TEST CONDITION		MEASUREMENT DETAIL	
CHANNEL	Channel 159	FREQUENCY RANGE	1GHz ~ 40GHz
INPUT POWER (SYSTEM)	120Vac, 60 Hz	DETECTOR FUNCTION	Peak (PK) Average (AV)
ENVIRONMENTAL CONDITIONS	25deg. C, 65%RH	TESTED BY	Kay Wu

ANTENNA POLARITY & TEST DISTANCE: HORIZONTAL AT 3 M										
FREQ. (MHz)	EMISSION LEVEL (dBuV/m)	READ LEVEL (dBuV)	LIMIT (dBuV/m)	MARGIN (dB)	ANTENNA FACTOR (dB/m)	CABLE LOSS (dB)	PREAMP FACTOR (dB)	ANTENNA HEIGHT (cm)	TABLE ANGLE (Degree)	REMARK
5725	40.43	38.19	60.74	-20.31	31.96	7.71	37.43	101	7	Average
5725	54.55	52.31	69.84	-15.29	31.96	7.71	37.43	101	7	Peak
5795	80.74	78.41			32.07	7.8	37.54	101	7	Average
5795	89.84	87.51			32.07	7.8	37.54	101	7	Peak
5850	40.88	38.41	60.74	-19.86	32.15	7.83	37.51	101	7	Average
5850	55.03	52.56	69.84	-14.81	32.15	7.83	37.51	101	7	Peak
ANTENNA POLARITY & TEST DISTANCE: VERTICAL AT 3 M										
FREQ. (MHz)	EMISSION LEVEL (dBuV/m)	READ LEVEL (dBuV)	LIMIT (dBuV/m)	MARGIN (dB)	ANTENNA FACTOR (dB/m)	CABLE LOSS (dB)	PREAMP FACTOR (dB)	ANTENNA HEIGHT (cm)	TABLE ANGLE (Degree)	REMARK
5725	41.3	39.06	68.73	-27.43	31.96	7.71	37.43	114	307	Average
5725	55.65	53.41	78.15	-22.5	31.96	7.71	37.43	114	307	Peak
5795	88.73	86.4			32.07	7.8	37.54	114	307	Average
5795	98.15	95.82			32.07	7.8	37.54	114	307	Peak
5850	41.61	39.14	68.73	-27.12	32.15	7.83	37.51	114	307	Average
5850	55.95	53.48	78.15	-22.2	32.15	7.83	37.51	114	307	Peak

**REMARKS:**

1. 5795MHz: Fundamental frequency.
2. 5725MHz & 5850MHz: Out of restricted band





A D T

**BELOW 1GHz WORST-CASE DATA : 802.11a**

EUT TEST CONDITION		MEASUREMENT DETAIL	
CHANNEL	Channel 157	FREQUENCY RANGE	30MHz ~ 1GHz
INPUT POWER (SYSTEM)	120Vac, 60 Hz	DETECTOR FUNCTION	Peak (PK) Average (AV)
ENVIRONMENTAL CONDITIONS	25deg. C, 65%RH	TESTED BY	Kay Wu

**ANTENNA POLARITY & TEST DISTANCE: HORIZONTAL AT 3 M**

FREQ. (MHz)	EMISSION LEVEL (dBuV/m)	READ LEVEL (dBuV)	LIMIT (dBuV/m)	MARGIN (dB)	ANTENNA FACTOR (dB/m)	CABLE LOSS (dB)	PREAMP FACTOR (dB)	ANTENNA HEIGHT (cm)	TABLE ANGLE (Degree)	REMARK
43.77	18.51	35.32	40	-21.49	13.59	0.71	31.11	119	14	Peak
160.95	16.01	33.85	43.5	-27.49	12.63	1.39	31.86	102	273	Peak
255.99	17.46	35.85	46	-28.54	11.65	1.85	31.89	107	263	Peak
384	21.54	36.21	46	-24.46	14.96	2.36	31.99	107	197	Peak
619.9	23.92	33.1	46	-22.08	19.84	3.15	32.17	111	319	Peak
784.4	27.06	32.81	46	-18.94	22.01	3.66	31.42	102	145	Peak

**ANTENNA POLARITY & TEST DISTANCE: VERTICAL AT 3 M**

FREQ. (MHz)	EMISSION LEVEL (dBuV/m)	READ LEVEL (dBuV)	LIMIT (dBuV/m)	MARGIN (dB)	ANTENNA FACTOR (dB/m)	CABLE LOSS (dB)	PREAMP FACTOR (dB)	ANTENNA HEIGHT (cm)	TABLE ANGLE (Degree)	REMARK
64.02	21.32	40.53	40	-18.68	11.47	0.86	31.54	107	248	Peak
161.49	15.51	33.42	43.5	-27.99	12.54	1.4	31.85	106	193	Peak
255.99	15.8	34.19	46	-30.2	11.65	1.85	31.89	102	262	Peak
443.5	20.48	33.68	46	-25.52	16.2	2.59	31.99	105	178	Peak
610.1	23.94	33.17	46	-22.06	19.73	3.12	32.08	109	237	Peak
797	27.09	32.63	46	-18.91	22.19	3.69	31.42	103	209	Peak

## 5.2 CONDUCTED EMISSION MEASUREMENT

### 5.2.1 LIMITS OF CONDUCTED EMISSION MEASUREMENT

FREQUENCY OF EMISSION (MHz)	CONDUCTED LIMIT (dB $\mu$ V)	
	Quasi-peak	Average
0.15 ~ 0.5	66 to 56	56 to 46
0.5 ~ 5	56	46
5 ~ 30	60	50

- NOTE:** 1. The lower limit shall apply at the transition frequencies.
2. The limit decreases in line with the logarithm of the frequency in the range of 0.15 to 0.50MHz.
3. All emanations from a class A/B digital device or system, including any network of conductors and apparatus connected thereto, shall not exceed the level of field strengths specified above.

### 5.2.2 TEST INSTRUMENTS

Same as item 4.2.2.

### 5.2.3 TEST PROCEDURES

Same as item 4.2.3.

### 5.2.4 DEVIATION FROM TEST STANDARD

No deviation.

### 5.2.5 TEST SETUP

Same as item 4.2.5.

### 5.2.6 EUT OPERATING CONDITIONS

Same as 4.1.6

### 5.2.7 TEST RESULTS

**CONDUCTED WORST-CASE DATA : 802.11a**

<b>PHASE</b>	Line 1	<b>6dB BANDWIDTH</b>	9kHz
--------------	--------	----------------------	------

No	Freq. [MHz]	Corr. Factor (dB)	Reading Value [dB (uV)]		Emission Level [dB (uV)]		Limit [dB (uV)]		Margin (dB)	
			Q.P.	AV.	Q.P.	AV.	Q.P.	AV.	Q.P.	AV.
1	0.15391	0.12	40.76	27.70	40.88	27.82	65.79	55.79	-24.90	-27.96
2	0.40781	0.15	45.03	39.31	45.18	39.46	57.69	47.69	-12.51	-8.23
<b>3</b>	<b>0.47422</b>	<b>0.16</b>	<b>45.44</b>	<b>38.11</b>	<b>45.60</b>	<b>38.27</b>	<b>56.44</b>	<b>46.44</b>	<b>-10.84</b>	<b>-8.17</b>
4	0.88828	0.20	40.80	33.55	41.00	33.75	56.00	46.00	-15.00	-12.25
5	1.21875	0.21	40.83	31.93	41.04	32.14	56.00	46.00	-14.96	-13.86
6	13.56250	0.86	55.45	53.25	56.31	54.11	60.00	50.00	-3.69	4.11

**REMARKS:**

1. Q.P. and AV. are abbreviations of quasi-peak and average individually.
2. The emission levels of other frequencies were very low against the limit.
3. Margin value = Emission level - Limit value
4. Correction factor = Insertion loss + Cable loss
5. Emission Level = Correction Factor + Reading Value.
6. No. 6 is NFC signal inductive with measurement system. Please check P63-64 to see test result for EUT with a suitable dummy load.

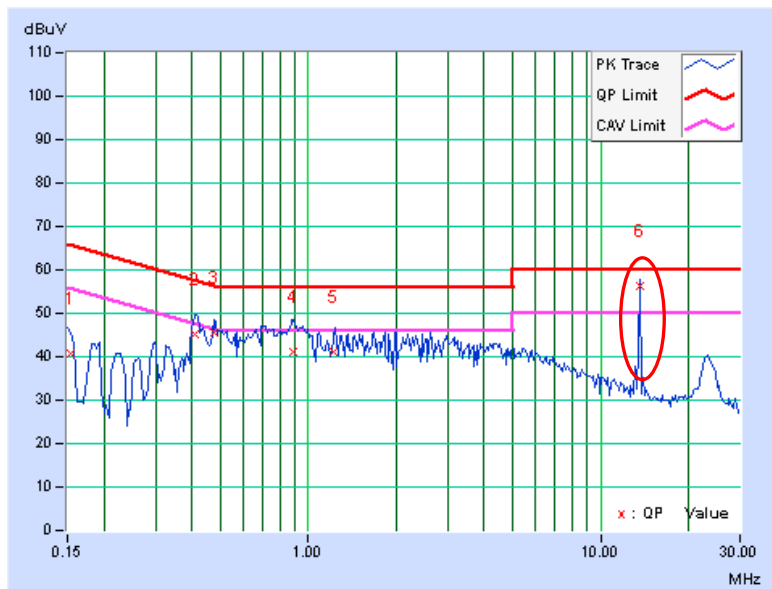

<b>PHASE</b>	Line 2	<b>6dB BANDWIDTH</b>	9kHz
--------------	--------	----------------------	------

No	Freq. [MHz]	Corr. Factor (dB)	Reading Value [dB (uV)]		Emission Level [dB (uV)]		Limit [dB (uV)]		Margin (dB)	
			Q.P.	AV.	Q.P.	AV.	Q.P.	AV.	Q.P.	AV.
			1	0.15391	0.17	43.34	33.58	43.51	33.75	65.79
2	0.41172	0.21	40.01	32.74	40.22	32.95	57.61	47.61	-17.39	-14.66
3	0.98984	0.25	35.67	27.60	35.92	27.85	56.00	46.00	-20.08	-18.15
4	1.58984	0.27	36.28	27.62	36.55	27.89	56.00	46.00	-19.45	-18.11
5	13.55859	0.71	54.37	51.87	55.08	52.58	60.00	50.00	-4.92	2.58
6	23.19922	1.00	32.54	21.39	33.54	22.39	60.00	50.00	-26.46	-27.61

**REMARKS:**

1. Q.P. and AV. are abbreviations of quasi-peak and average individually.
2. The emission levels of other frequencies were very low against the limit.
3. Margin value = Emission level - Limit value
4. Correction factor = Insertion loss + Cable loss
5. Emission Level = Correction Factor + Reading Value.
6. No. 5 is NFC signal inductive with measurement system. Please check P63-64 to see test result for EUT with a suitable dummy load.

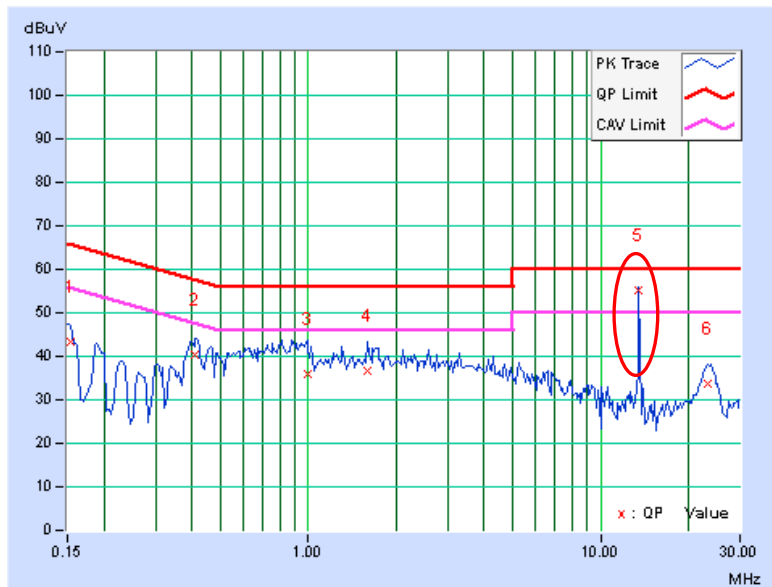

### Test with suitable dummy load

<b>PHASE</b>	Line 1	<b>6dB BANDWIDTH</b>	9kHz
--------------	--------	----------------------	------

No	Freq. [MHz]	Corr. Factor (dB)	Reading Value		Emission Level		Limit		Margin	
			[dB (uV)]		[dB (uV)]		[dB (uV)]		(dB)	
			Q.P.	AV.	Q.P.	AV.	Q.P.	AV.	Q.P.	AV.
1	0.15391	0.12	46.65	37.79	46.77	37.91	65.79	55.79	-19.01	-17.87
2	0.46250	0.16	40.04	30.90	40.20	31.06	56.65	46.65	-16.45	-15.59
3	0.88438	0.20	39.68	29.79	39.88	29.99	56.00	46.00	-16.12	-16.01
4	2.49219	0.26	38.58	29.89	38.84	30.15	56.00	46.00	-17.16	-15.85
5	6.79688	0.49	34.03	24.03	34.52	24.52	60.00	50.00	-25.48	-25.48
6	18.04688	1.12	26.76	16.61	27.88	17.73	60.00	50.00	-32.12	-32.27

#### REMARKS:

1. Q.P. and AV. are abbreviations of quasi-peak and average individually.
2. The emission levels of other frequencies were very low against the limit.
3. Margin value = Emission level - Limit value
4. Correction factor = Insertion loss + Cable loss
5. Emission Level = Correction Factor + Reading Value.

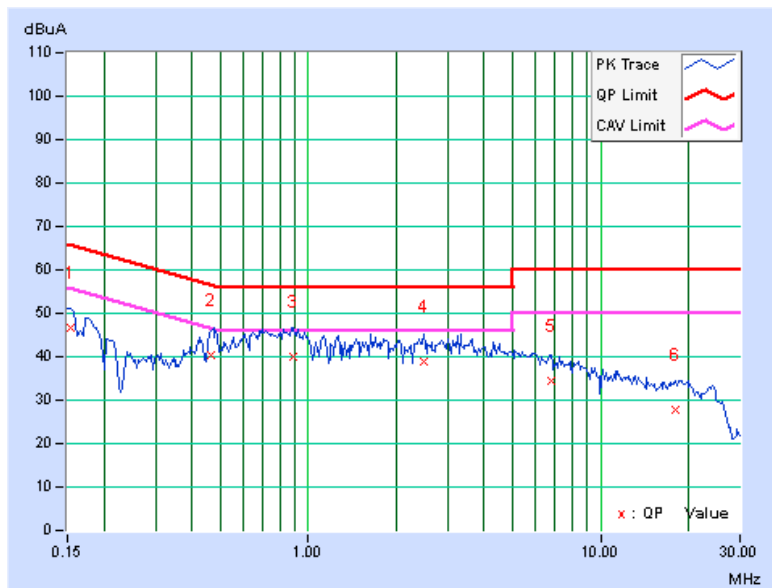

<b>PHASE</b>	Line 2	<b>6dB BANDWIDTH</b>	9kHz
--------------	--------	----------------------	------

No	Freq.	Corr. Factor	Reading Value		Emission Level		Limit		Margin	
	[MHz]		[dB (uV)]		[dB (uV)]		[dB (uV)]		(dB)	
			Q.P.	AV.	Q.P.	AV.	Q.P.	AV.	Q.P.	AV.
1	0.15000	0.18	44.74	35.49	44.92	35.67	66.00	56.00	-21.08	-20.33
2	0.47031	0.21	43.04	36.26	43.25	36.47	56.51	46.51	-13.25	-10.03
3	0.96641	0.25	38.28	29.76	38.53	30.01	56.00	46.00	-17.47	-15.99
4	1.44531	0.26	36.91	28.23	37.17	28.49	56.00	46.00	-18.83	-17.51
5	9.46484	0.57	25.38	17.58	25.95	18.15	60.00	50.00	-34.05	-31.85
6	24.05859	1.02	29.80	18.52	30.82	19.54	60.00	50.00	-29.18	-30.46

**REMARKS:**

1. Q.P. and AV. are abbreviations of quasi-peak and average individually.
2. The emission levels of other frequencies were very low against the limit.
3. Margin value = Emission level - Limit value
4. Correction factor = Insertion loss + Cable loss
5. Emission Level = Correction Factor + Reading Value.

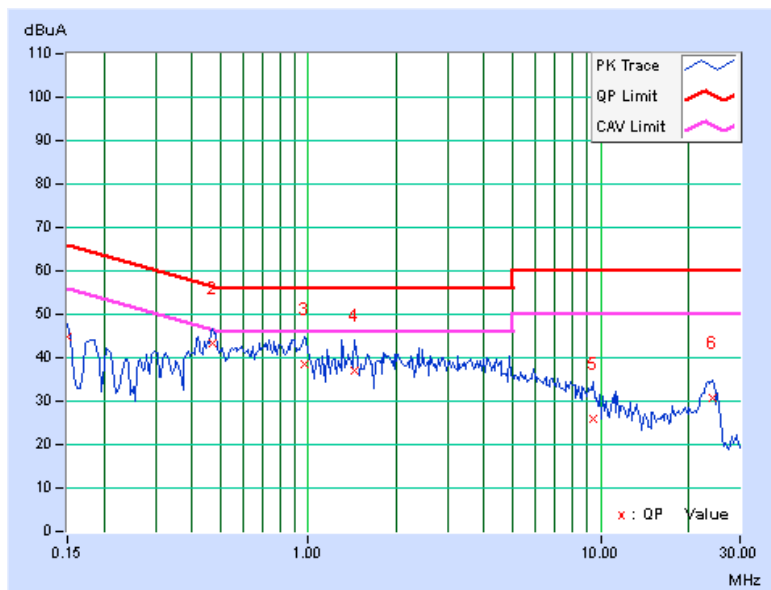

### **5.3 6dB BANDWIDTH MEASUREMENT**

#### **5.3.1 LIMITS OF 6dB BANDWIDTH MEASUREMENT**

The minimum of 6dB Bandwidth Measurement is 0.5MHz.

#### **5.3.2 TEST SETUP**

Same as item 4.3.2.

#### **5.3.3 TEST INSTRUMENTS**

Refer to section 4.1.2 to get information of above instrument.

#### **5.3.4 TEST PROCEDURE**

Same as item 4.3.4.

#### **5.3.5 DEVIATION FROM TEST STANDARD**

No deviation.

#### **5.3.6 EUT OPERATING CONDITIONS**

Same as item 4.3.6.



### 5.3.7 TEST RESULTS

#### 802.11a

CHANNEL	CHANNEL FREQUENCY (MHz)	6dB BANDWIDTH (MHz)	MINIMUM LIMIT (MHz)	PASS / FAIL
149	5745	16.37	0.5	PASS
157	5785	16.43	0.5	PASS
165	5825	16.42	0.5	PASS

#### 802.11n (20MHz)

CHANNEL	CHANNEL FREQUENCY (MHz)	6dB BANDWIDTH (MHz)	MINIMUM LIMIT (MHz)	PASS / FAIL
149	5745	17.63	0.5	PASS
157	5785	17.65	0.5	PASS
165	5825	17.61	0.5	PASS

#### 802.11n (40MHz)

CHANNEL	CHANNEL FREQUENCY (MHz)	6dB BANDWIDTH (MHz)	MINIMUM LIMIT (MHz)	PASS / FAIL
151	5755	35.21	0.5	PASS
159	5795	35.82	0.5	PASS





A D T

## **5.4 MAXIMUM OUTPUT POWER**

### **5.4.1 LIMITS OF MAXIMUM OUTPUT POWER MEASUREMENT**

For systems using digital modulation in the 5725–5850 MHz bands: 1 Watt (30dBm)

### **5.4.2 TEST SETUP**

Same as Item 4.4.2.

### **5.4.3 INSTRUMENTS**

Refer to section 4.1.2 to get information of above instrument.

### **5.4.4 TEST PROCEDURES**

Same as Item 4.4.4.

### **5.4.5 DEVIATION FROM TEST STANDARD**

No deviation.

### **5.4.6 EUT OPERATING CONDITIONS**

Same as Item 4.3.6.



A D T

## 5.4.7 TEST RESULTS

### 802.11a

CHANNEL	FREQUENCY (MHz)	PEAK POWER (mW)	PEAK POWER (dBm)	LIMIT (dBm)	PASS/FAIL
149	5745	109.144	20.38	30	PASS
157	5785	120.504	20.81	30	PASS
165	5825	118.577	20.74	30	PASS

### 802.11n (20MHz)

CHANNEL	FREQUENCY (MHz)	PEAK POWER (mW)	PEAK POWER (dBm)	LIMIT (dBm)	PASS/FAIL
149	5745	94.406	19.75	30	PASS
157	5785	111.429	20.47	30	PASS
165	5825	110.408	20.43	30	PASS

### 802.11n (40MHz)

CHANNEL	FREQUENCY (MHz)	PEAK POWER (mW)	PEAK POWER (dBm)	LIMIT (dBm)	PASS/FAIL
151	5755	94.842	19.77	30	PASS
159	5795	103.276	20.14	30	PASS



A D T

## **5.5 POWER SPECTRAL DENSITY MEASUREMENT**

### **5.5.1 LIMITS OF POWER SPECTRAL DENSITY MEASUREMENT**

The Maximum of Power Spectral Density Measurement is 8dBm.

### **5.5.2 TEST SETUP**

Same as item 4.5.2.

### **5.5.3 TEST INSTRUMENTS**

Refer to section 4.1.2 to get information of above instrument.

### **5.5.4 TEST PROCEDURE.**

Same as item 4.5.4.

### **5.5.5 DEVIATION FROM TEST STANDARD**

No deviation.

### **5.5.6 EUT OPERATING CONDITION**

Same as item 4.3.6.



### 5.5.7 TEST RESULTS

#### 802.11a

Channel	FREQ. (MHz)	PSD (dBm/3kHz)	Limit (dBm/3kHz)	PASS /FAIL
149	5745	-15.49	8	PASS
157	5785	-13.44	8	PASS
165	5825	-13.54	8	PASS

#### 802.11n (20MHz)

Channel	FREQ. (MHz)	PSD (dBm/3kHz)	Limit (dBm/3kHz)	PASS /FAIL
149	5745	-15.16	8	PASS
157	5785	-14.64	8	PASS
165	5825	-14.33	8	PASS

#### 802.11n (40MHz)

Channel	FREQ. (MHz)	PSD (dBm/3kHz)	Limit (dBm/3kHz)	PASS /FAIL
151	5755	-19.62	8	PASS
159	5795	-18.48	8	PASS

## **5.6 CONDUCTED OUT OF BAND EMISSION MEASUREMENT**

### **5.6.1 LIMITS OF OUT OF BAND EMISSION MEASUREMENT**

Below  $-20\text{dB}$  of the highest emission level of operating band (in 100kHz Resolution Bandwidth).

### **5.6.2 TEST SETUP**

Same as Item 4.6.2

### **5.6.3 TEST INSTRUMENTS**

Refer to section 4.1.2 to get information of above instrument.

### **5.6.4 TEST PROCEDURE**

Same as Item 4.6.4

### **5.6.5 DEVIATION FROM TEST STANDARD**

No deviation.

### **5.6.6 EUT OPERATING CONDITION**

Same as Item 4.3.6

### **5.6.7 TEST RESULTS**

The spectrum plots are attached on the following pages. D1 line indicates the highest level, and D2 line indicates the 20dB offset below D1. It shows compliance with the requirement.



A D T

802.11a

### CH 149

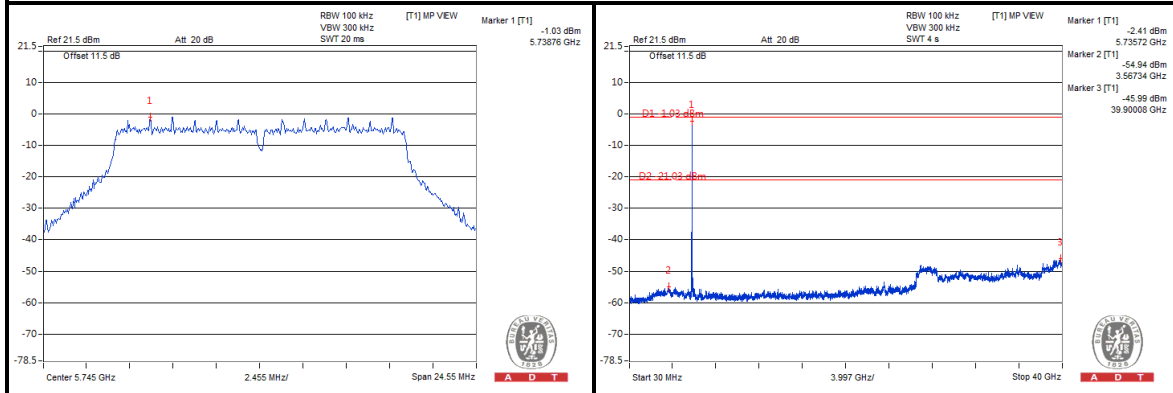

### CH 157

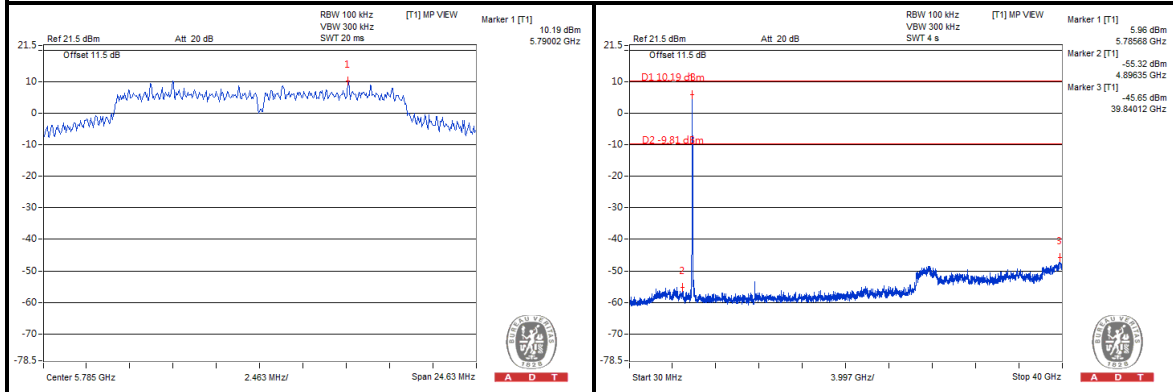

### CH 165

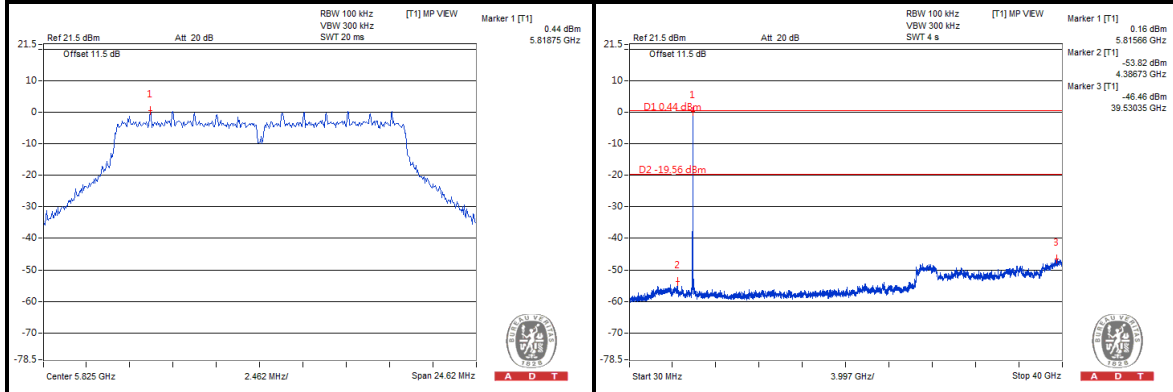



A D T

### 802.11n (20MHz)

#### CH 149

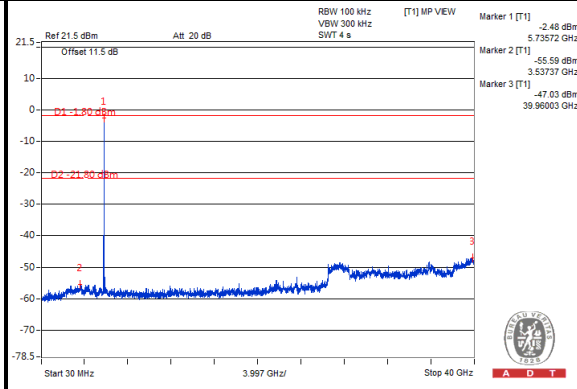
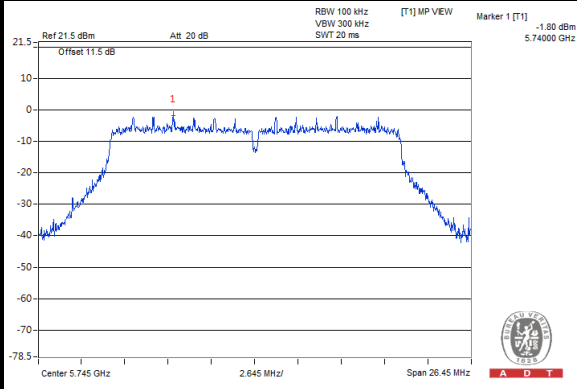

#### CH 157

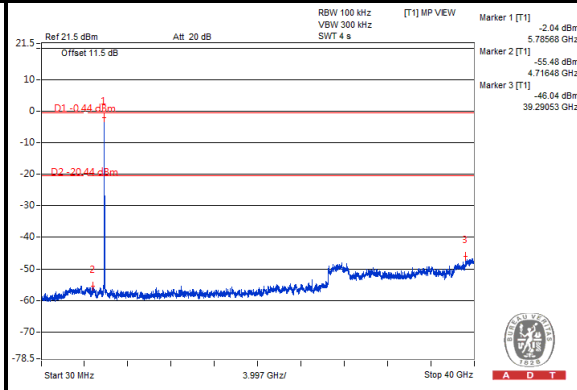
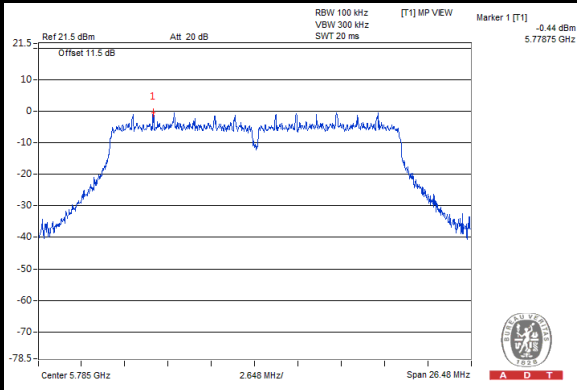

#### CH 165

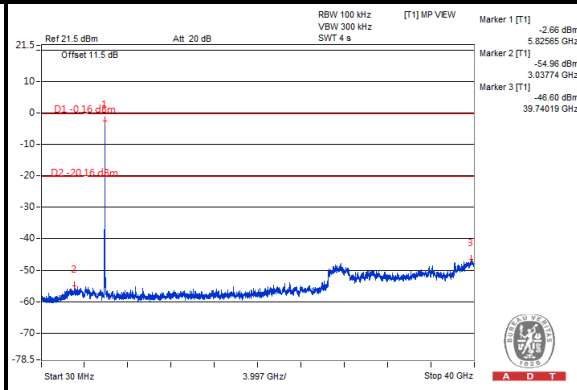
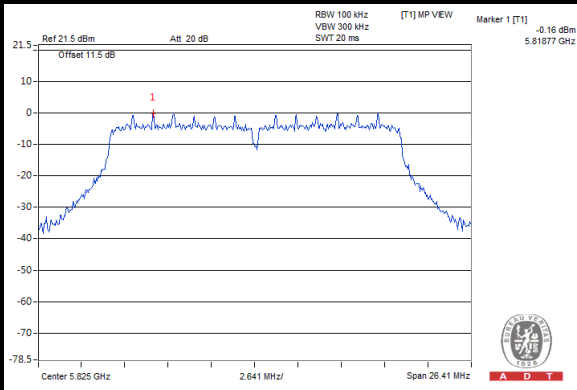



A D T

### 802.11n (40MHz)

#### CH 151

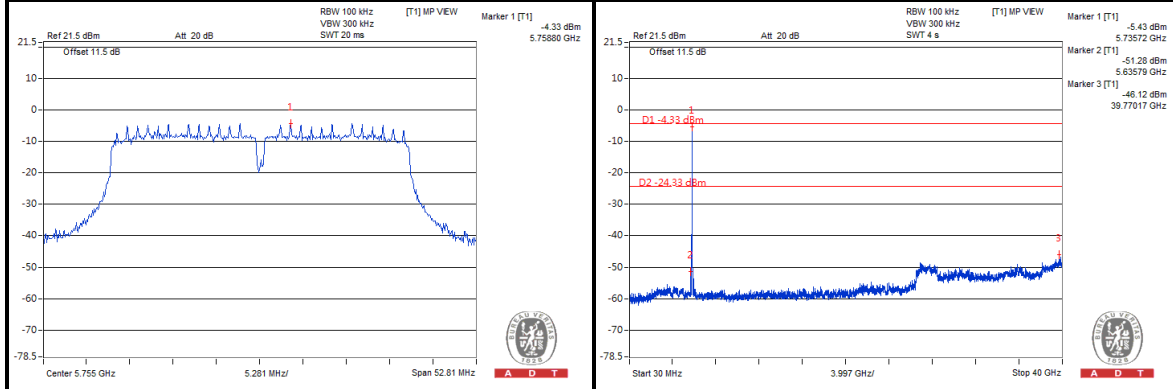

#### CH 159

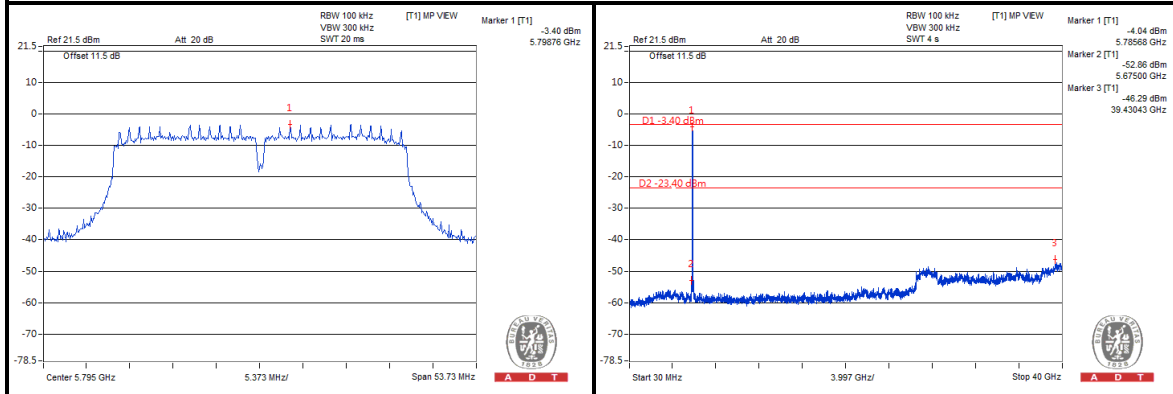





A D T

## 6. PHOTOGRAPHS OF THE TEST CONFIGURATION

Please refer to the attached file (Test Setup Photo).



## 7. INFORMATION ON THE TESTING LABORATORIES

We, Bureau Veritas Consumer Products Services (H.K.) Ltd., Taoyuan Branch, were founded in 1988 to provide our best service in EMC, Radio, Telecom and Safety consultation. Our laboratories are accredited and approved according to ISO/IEC 17025.

If you have any comments, please feel free to contact us at the following:

**Linko EMC/RF Lab:**

Tel: 886-2-26052180

Fax: 886-2-26051924

**Hsin Chu EMC/RF Lab:**

Tel: 886-3-5935343

Fax: 886-3-5935342

**Hwa Ya EMC/RF/Safety Telecom Lab:**

Tel: 886-3-3183232

Fax: 886-3-3270892

**Email:** [service.adt@tw.bureauveritas.com](mailto:service.adt@tw.bureauveritas.com)

**Web Site:** [www.bureauveritas-adt.com](http://www.bureauveritas-adt.com)

The address and road map of all our labs can be found in our web site also.



A D T

## 8. APPENDIX A - MODIFICATIONS RECORDERS FOR ENGINEERING CHANGES TO THE EUT BY THE LAB

No any modifications are made to the EUT by the lab during the test.

---END---