



FCC TEST REPORT (15.407)

REPORT NO.: RF130223C16-5
MODEL NO.: C6750
FCC ID: V65C6750
RECEIVED: Feb. 23, 2013
TESTED: Mar. 11, 2013 ~ Mar. 16, 2013
ISSUED: Mar. 25, 2013

APPLICANT: Kyocera Communications, Inc.

ADDRESS: 8611 Balboa Ave., San Diego, CA 92123, USA

ISSUED BY: Bureau Veritas Consumer Products Services
(H.K.) Ltd., Taoyuan Branch

LAB ADDRESS: No. 47, 14th Ling, Chia Pau Vil., Lin Kou Dist.,
New Taipei City, Taiwan (R.O.C)

TEST LOCATION: No. 19, Hwa Ya 2nd Rd, Wen Hwa Tsuen, Kwei
Shan Hsiang, Taoyuan Hsien 333, Taiwan, R.O.C.

This report should not be used by the client to claim product certification, approval, or endorsement by TAF or any government agencies.



This report is for your exclusive use. Any copying or replication of this report to or for any other person or entity, or use of our name or trademark, is permitted only with our prior written permission. This report sets forth our findings solely with respect to the test samples identified herein. The results set forth in this report are not indicative or representative of the quality or characteristics of the lot from which a test sample was taken or any similar or identical product unless specifically and expressly noted. Our report includes all of the tests requested by you and the results thereof based upon the information that you provided to us. You have 60 days from date of issuance of this report to notify us of any material error or omission caused by our negligence, provided, however, that such notice shall be in writing and shall specifically address the issue you wish to raise. A failure to raise such issue within the prescribed time shall constitute your unqualified acceptance of the completeness of this report, the tests conducted and the correctness of the report contents. Unless specific mention, the uncertainty of measurement has been explicitly taken into account to declare the compliance or non-compliance to the specification

TABLE OF CONTENTS

RELEASE CONTROL RECORD	4
1. CERTIFICATION	5
2. SUMMARY OF TEST RESULTS	6
2.1 MEASUREMENT uncertainty	6
3. GENERAL INFORMATION	7
3.1 GENERAL DESCRIPTION OF EUT	7
3.2 DESCRIPTION OF TEST MODES	8
3.2.1 Test Mode Applicability and tested channel detail	10
3.3 DESCRIPTION OF SUPPORT UNITS	13
3.3.1 CONFIGURATION OF SYSTEM UNDER TEST	13
3.4 Duty cycle of test signal	14
3.5 GENERAL DESCRIPTION OF APPLIED STANDARDS	14
4. TEST TYPES AND RESULTS	15
4.1 Radiated Emission AND BANDEDGE Measurement	15
4.1.1 LIMITS OF RADIATED EMISSION AND BANDEDGE MEASUREMENT	15
4.1.2 LIMITS OF UNWANTED EMISSION OUT OF THE RESTRICTED BANDS	15
4.1.3 TEST INSTRUMENTS	16
4.1.4 TEST PROCEDURES	17
4.1.5 DEVIATION FROM TEST STANDARD	17
4.1.6 TEST SETUP	18
4.1.7 EUT OPERATING CONDITION	18
4.1.8 Test RESULTS	19
4.2 CONDUCTED EMISSION MEASUREMENT	45
4.2.1 LIMITS OF CONDUCTED EMISSION MEASUREMENT	45
4.2.2 TEST INSTRUMENTS	45
4.2.3 TEST PROCEDURES	46
4.2.4 DEVIATION FROM TEST STANDARD	46
4.2.5 TEST SETUP	46
4.2.6 EUT OPERATING CONDITIONS	46
4.2.7 TEST RESULTS	47
4.3 Peak transmit power MEASUREMENT	51
4.3.1 LIMITS OF PEAK TRANSMIT POWER MEASUREMENT	51
4.3.2 TEST SETUP	51
4.3.3 TEST INSTRUMENTS	51
4.3.4 TEST PROCEDURE	52
4.3.5 DEVIATION FROM TEST STANDARD	52
4.3.6 EUT OPERATING CONDITIONS	52
4.3.7 TEST RESULTS	53
4.4 PEAK power spectral density measurement	55
4.4.1 LIMITS OF PEAK POWER SPECTRAL DENSITY MEASUREMENT	55
4.4.2 TEST SETUP	55
4.4.3 TEST INSTRUMENTS	55
4.4.4 TEST PROCEDURES	55
4.4.5 DEVIATION FROM TEST STANDARD	56
4.4.6 EUT OPERATING CONDITIONS	56



A D T

4.4.7	TEST RESULTS	56
4.5	Peak power EXCURSION MEASUREMENT	58
4.5.1	LIMITS OF PEAK POWER EXCURSION MEASUREMENT	58
4.5.2	TEST SETUP	58
4.5.3	TEST INSTRUMENTS	58
4.5.4	TEST PROCEDURE	58
4.5.5	DEVIATION FROM TEST STANDARD	58
4.5.6	EUT OPERATING CONDITIONS	58
4.5.7	TEST RESULTS	59
4.6	FREQUENCY STABILITY	62
4.6.1	LIMITS OF FREQUENCY STABILITY MEASUREMENT	62
4.6.2	TEST SETUP	62
4.6.3	TEST INSTRUMENTS	62
4.6.4	TEST PROCEDURE	63
4.6.5	DEVIATION FROM TEST STANDARD	63
4.6.6	EUT OPERATING CONDITION	63
4.6.7	TEST RESULTS	64
5.	PHOTOGRAPHS OF THE TEST CONFIGURATION	65
6.	INFORMATION ON THE TESTING LABORATORIES	66
7.	APPENDIX A - Modifications recorders for engineering changes to the eut BY THE LAB	67



A D T

RELEASE CONTROL RECORD

ISSUE NO.	REASON FOR CHANGE	DATE ISSUED
RF130223C16-5	Original release	Mar. 25, 2013

1. CERTIFICATION

PRODUCT: PDA Phone
MODEL NO.: C6750
BRAND: Kyocera
APPLICANT: Kyocera Communications, Inc.
TESTED: Mar. 11, 2013 ~ Mar. 16, 2013
TEST SAMPLE: Identical Prototype
STANDARDS: **FCC Part 15, Subpart E (Section 15.407)**
ANSI C63.10-2009

The above equipment (model: C6750) has been tested by **Bureau Veritas Consumer Products Services (H.K.) Ltd., Taoyuan Branch**, and found compliance with the requirement of the above standards. The test record, data evaluation & Equipment Under Test (EUT) configurations represented herein are true and accurate accounts of the measurements of the sample's EMC characteristics under the conditions specified in this report.

PREPARED BY : Vera Huang , **DATE** : Mar. 25, 2013

Vera Huang / Specialist

APPROVED BY : Sam Chen , **DATE** : Mar. 25, 2013

Sam Chen / Assistant Manager

2. SUMMARY OF TEST RESULTS

The EUT has been tested according to the following specifications:

APPLIED STANDARD: FCC PART 15, SUBPART E (SECTION 15.407)			
STANDARD SECTION	TEST TYPE	RESULT	REMARK
15.407(b)(6)	AC Power Conducted Emission	PASS	Meet the requirement of limit. Minimum passing margin is -8.17dB at 0.47422MHz.
15.407(b/1/2/3) (b)(6)	Spurious Emissions	PASS	Meet the requirement of limit. Minimum passing margin is -0.94dB at 5725MHz.
15.407(a/1/2)	Peak Transmit Power	PASS	Meet the requirement of limit.
15.407(a)(6)	Peak Power Excursion	PASS	Meet the requirement of limit.
15.407(a/1/2)	Peak Power Spectral Density	PASS	Meet the requirement of limit.
15.407(g)	Frequency Stability	PASS	Meet the requirement of limit.
15.203	Antenna Requirement	PASS	No antenna connector is used.

2.1 MEASUREMENT UNCERTAINTY

Where relevant, the following measurement uncertainty levels have been estimated for tests performed on the EUT as specified in CISPR 16-4-2:

MEASUREMENT	FREQUENCY	UNCERTAINTY
Conducted emissions	9kHz~30MHz	2.44 dB
Radiated emissions	30MHz ~ 200MHz	2.93 dB
	200MHz ~ 1000MHz	2.95 dB
	1GHz ~ 18GHz	2.26 dB
	18GHz ~ 40GHz	1.94 dB

This uncertainty represents an expanded uncertainty expressed at approximately the 95% confidence level using a coverage factor of $k = 2$.



3. GENERAL INFORMATION

3.1 GENERAL DESCRIPTION OF EUT

EUT	PDA Phone
MODEL NO.	C6750
POWER SUPPLY	5.0Vdc (adapter or host equipment) 3.8Vdc (Li-ion battery)
MODULATION TYPE	256QAM, 64QAM, 16QAM, QPSK, BPSK
MODULATION TECHNOLOGY	OFDM
TRANSFER RATE	802.11a: 54.0/ 48.0/ 36.0/ 24.0/ 18.0/ 12.0/ 9.0/ 6.0Mbps 802.11n: up to MCS7
OPERATING FREQUENCY	5180 ~ 5240MHz, 5260 ~ 5320MHz & 5500 ~ 5700MHz
NUMBER OF CHANNEL	5180 ~ 5240MHz: 4 for 802.11a, 802.11n (20MHz) 2 for 802.11n (40MHz) 5260 ~ 5320MHz: 4 for 802.11a, 802.11n (20MHz) 2 for 802.11n (40MHz) 5500 ~ 5700MHz: 8 for 802.11a, 802.11n (20MHz) 3 for 802.11n (40MHz)
OUTPUT POWER	15.704mW for 5180 ~ 5240MHz 15.959mW for 5260 ~ 5320MHz 16.255mW for 5500 ~ 5700MHz
ANTENNA TYPE	Fixed Internal antenna with -1dBi gain (5180 ~ 5240MHz) Fixed Internal antenna with -1dBi gain (5260 ~ 5320MHz) Fixed Internal antenna with -1dBi gain (5500 ~ 5700MHz)
ANTENNA CONNECTOR	NA
DATA CABLE	Refer to Note as below
I/O PORTS	Refer to user's manual
ACCESSORY DEVICES	Refer to Note as below

NOTE:

1. The EUT has following accessories.

No.	Product	Brand	MODEL	Description
1	AC Adapter	Kyocera	SCP-39ADT	I/P: 100-240Vac, 0.2A O/P: 5Vdc, 1A
2	Li-ion Battery	Kyocera	SCP-53LBPS	Rating: 3.8Vdc, 2000mAh
3	USB cable	Kyocera	SCP-14SDC	1.1m shielded cable without core

2. The EUT provides one completed transmitter and one receiver.

MODULATION MODE	TX FUNCTION
802.11b	1TX
802.11g	1TX
802.11a	1TX
802.11n (20MHz)	1TX
802.11n (40MHz)	1TX

3. The above EUT information is declared by the manufacturer and for more detailed features description, please refer to the manufacturer's specifications or User's Manual.

3.2 DESCRIPTION OF TEST MODES

FOR 5180 ~ 5240MHz

4 channels are provided for 802.11a, 802.11n (20MHz):

CHANNEL	FREQUENCY	CHANNEL	FREQUENCY
36	5180 MHz	44	5220 MHz
40	5200 MHz	48	5240 MHz

2 channels are provided for 802.11n (40MHz):

CHANNEL	FREQUENCY	CHANNEL	FREQUENCY
38	5190 MHz	46	5230 MHz

FOR 5260 ~ 5320MHz

4 channels are provided for 802.11a, 802.11n (20MHz):

CHANNEL	FREQUENCY	CHANNEL	FREQUENCY
52	5260 MHz	60	5300 MHz
56	5280 MHz	64	5320 MHz

2 channels are provided for 802.11n (40MHz):

CHANNEL	FREQUENCY	CHANNEL	FREQUENCY
54	5270 MHz	62	5310 MHz



FOR 5500 ~ 5700MHz

8 channels are provided for 802.11a, 802.11n (20MHz):

CHANNEL	FREQUENCY	CHANNEL	FREQUENCY
100	5500MHz	116	5580MHz
104	5520MHz	132	5660MHz
108	5540MHz	136	5680MHz
112	5560MHz	140	5700MHz

3 channels are provided for 802.11n (40MHz):

CHANNEL	FREQUENCY	CHANNEL	FREQUENCY
102	5510MHz	134	5670MHz
110	5550MHz		



3.2.1 TEST MODE APPLICABILITY AND TESTED CHANNEL DETAIL

EUT CONFIGURE MODE	APPLICABLE TO				DESCRIPTION
	RE≥1G	RE<1G	PLC	APCM	
-	√	√	√	√	-

Where **RE≥1G**: Radiated Emission above 1GHz **RE<1G**: Radiated Emission below 1GHz
PLC: Power Line Conducted Emission **APCM**: Antenna Port Conducted Measurement

NOTE: The EUT had been pre-tested on the positioned of each 3 axis. The worst case was found when positioned on **Y-plane** for 5180~5320MHz and **Z-plane** for 5500~5700MHz.

RADIATED EMISSION TEST (ABOVE 1GHz):

- Pre-Scan has been conducted to determine the worst-case mode from all possible combinations between available modulations, data rates and antenna ports (if EUT with antenna diversity architecture).
- Following channel(s) was (were) selected for the final test as listed below.

MODE	FREQ. BAND (MHz)	AVAILABLE CHANNEL	TESTED CHANNEL	MODULATION TECHNOLOGY	MODULATION TYPE	DATA RATE (Mbps)
802.11a	5180-5240	36 to 48	36, 44, 48	OFDM	BPSK	6.0
802.11n (20MHz)		36 to 48	36, 44, 48	OFDM	BPSK	6.5
802.11n (40MHz)		38 to 46	38, 46	OFDM	BPSK	13.5
802.11a	5260-5320	52 to 64	52, 60, 64	OFDM	BPSK	6.0
802.11n (20MHz)		52 to 64	52, 60, 64	OFDM	BPSK	6.5
802.11n (40MHz)		54 to 62	54, 62	OFDM	BPSK	13.5
802.11a	5500-5700	100 to 140	100, 116, 140	OFDM	BPSK	6.0
802.11n (20MHz)		100 to 140	100, 116, 140	OFDM	BPSK	6.5
802.11n (40MHz)		102 to 134	102, 110, 134	OFDM	BPSK	13.5

RADIATED EMISSION TEST (BELOW 1GHz):

- Pre-Scan has been conducted to determine the worst-case mode from all possible combinations between available modulations, data rates and antenna ports (if EUT with antenna diversity architecture).
- Following channel(s) was (were) selected for the final test as listed below.

MODE	FREQ. BAND (MHz)	AVAILABLE CHANNEL	TESTED CHANNEL	MODULATION TECHNOLOGY	MODULATION TYPE	DATA RATE (Mbps)
802.11a	5500-5700	100 to 140	140	OFDM	BPSK	6.0



POWER LINE CONDUCTED EMISSION TEST:

- Pre-Scan has been conducted to determine the worst-case mode from all possible combinations between available modulations, data rates and antenna ports (if EUT with antenna diversity architecture).
- Following channel(s) was (were) selected for the final test as listed below.

MODE	FREQ. BAND (MHz)	AVAILABLE CHANNEL	TESTED CHANNEL	MODULATION TECHNOLOGY	MODULATION TYPE	DATA RATE (Mbps)
802.11a	5500-5700	100 to 140	140	OFDM	BPSK	6.0

BANDEDGE MEASUREMENT:

- Pre-Scan has been conducted to determine the worst-case mode from all possible combinations between available modulations, data rates and antenna ports (if EUT with antenna diversity architecture).
- Following channel(s) was (were) selected for the final test as listed below.

MODE	FREQ. BAND (MHz)	AVAILABLE CHANNEL	TESTED CHANNEL	MODULATION TECHNOLOGY	MODULATION TYPE	DATA RATE (Mbps)
802.11a	5180-5240	36 to 48	36, 44, 48	OFDM	BPSK	6.0
802.11n (20MHz)		36 to 48	36, 44, 48	OFDM	BPSK	6.5
802.11n (40MHz)		38 to 46	38, 46	OFDM	BPSK	13.5
802.11a	5260-5320	52 to 64	52, 60, 64	OFDM	BPSK	6.0
802.11n (20MHz)		52 to 64	52, 60, 64	OFDM	BPSK	6.5
802.11n (40MHz)		54 to 62	54, 62	OFDM	BPSK	13.5
802.11a	5500-5700	100 to 140	100, 116, 140	OFDM	BPSK	6.0
802.11n (20MHz)		100 to 140	100, 116, 140	OFDM	BPSK	6.5
802.11n (40MHz)		102 to 134	102, 110, 134	OFDM	BPSK	13.5

**ANTENNA PORT CONDUCTED MEASUREMENT:**

- This item includes all test value of each mode, but only includes spectrum plot of worst value of each mode.
- Pre-Scan has been conducted to determine the worst-case mode from all possible combinations between available modulations, data rates and antenna ports (if EUT with antenna diversity architecture).
- Following channel(s) was (were) selected for the final test as listed below.

MODE	FREQ. BAND (MHz)	AVAILABLE CHANNEL	TESTED CHANNEL	MODULATION TECHNOLOGY	MODULATION TYPE	DATA RATE (Mbps)
802.11a	5180-5240	36 to 48	36, 44, 48	OFDM	BPSK	6.0
802.11n (20MHz)		36 to 48	36, 44, 48	OFDM	BPSK	6.5
802.11n (40MHz)		38 to 46	38, 46	OFDM	BPSK	13.5
802.11a	5260-5320	52 to 64	52, 60, 64	OFDM	BPSK	6.0
802.11n (20MHz)		52 to 64	52, 60, 64	OFDM	BPSK	6.5
802.11n (40MHz)		54 to 62	54, 62	OFDM	BPSK	13.5
802.11a	5500-5700	100 to 140	100, 116, 140	OFDM	BPSK	6.0
802.11n (20MHz)		100 to 140	100, 116, 140	OFDM	BPSK	6.5
802.11n (40MHz)		102 to 134	102, 110, 134	OFDM	BPSK	13.5

TEST CONDITION:

APPLICABLE TO	ENVIRONMENTAL CONDITIONS	INPUT POWER	TESTED BY
RE \geq 1G	25deg. C, 65%RH	120Vac, 60Hz	Kay Wu
RE $<$ 1G	25deg. C, 65%RH	120Vac, 60Hz	Kay Wu
PLC	25deg. C, 65%RH	120Vac, 60Hz	Anson Lin
APCM	25deg. C, 65%RH	120Vac, 60Hz	Howard Kao

3.3 DESCRIPTION OF SUPPORT UNITS

The EUT has been tested as an independent unit together with other necessary accessories or support units. The following support units or accessories were used to form a representative test configuration during the tests.

NO.	PRODUCT	BRAND	MODEL NO.	SERIAL NO.	FCC ID
1	Earphone	GALIEN	HF-HB04D	NA	NA

NO.	SIGNAL CABLE DESCRIPTION OF THE ABOVE SUPPORT UNITS
1	1.4m non-shielded cable without core.

NOTE:

1. All power cords of the above support units are non shielded (1.8m).
2. Item 1 was provided by manufacturer.

3.3.1 CONFIGURATION OF SYSTEM UNDER TEST

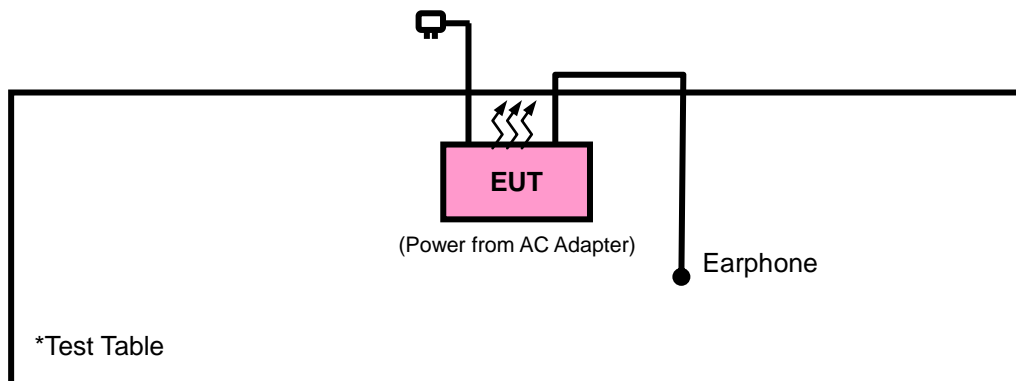

3.4 DUTY CYCLE OF TEST SIGNAL

If duty cycle is < 98%, duty factor shall be considered.

802.11a: Duty cycle = $2.323/7.45 = 0.312$, Duty factor = $10 * \log(1/0.312) = 5.06$

802.11n (20MHz): Duty cycle = $1.899/2.412 = 0.787$, Duty factor = $10 * \log(1/0.787) = 1.04$

802.11n (40MHz): Duty cycle = $1.891/2.404 = 0.786$, Duty factor = $10 * \log(1/0.786) = 1.05$



3.5 GENERAL DESCRIPTION OF APPLIED STANDARDS

The EUT is a RF Product. According to the specifications of the manufacturer, it must comply with the requirements of the following standards:

FCC Part 15, Subpart E (15.407)

ANSI C63.10-2009

KDB 789033 D01 General UNII Test Procedures v01r02

All test items have been performed and recorded as per the above standards.

4. TEST TYPES AND RESULTS

4.1 RADIATED EMISSION AND BANDEDGE MEASUREMENT

4.1.1 LIMITS OF RADIATED EMISSION AND BANDEDGE MEASUREMENT

Radiated emissions which fall in the restricted bands must comply with the radiated emission limits specified as below table:

FREQUENCIES (MHz)	FIELD STRENGTH (microvolts/meter)	MEASUREMENT DISTANCE (meters)
0.009 ~ 0.490	2400/F(kHz)	300
0.490 ~ 1.705	24000/F(kHz)	30
1.705 ~ 30.0	30	30
30 ~ 88	100	3
88 ~ 216	150	3
216 ~ 960	200	3
Above 960	500	3

NOTE:

1. The lower limit shall apply at the transition frequencies.
2. Emission level (dBuV/m) = 20 log Emission level (uV/m).
3. For frequencies above 1000MHz, the field strength limits are based on average detector, however, the peak field strength of any emission shall not exceed the maximum permitted average limits, specified above by more than 20dB under any condition of modulation.

4.1.2 LIMITS OF UNWANTED EMISSION OUT OF THE RESTRICTED BANDS

EIRP LIMIT (dBm)	EQUIVALENT FIELD STRENGTH AT 3m (dBµV/m)
PK	PK
-27	68.3

NOTE: The following formula is used to convert the equipment isotropic radiated power (eirp) to field strength:

$$E = \frac{1000000\sqrt{30P}}{3} \mu\text{V/m, where P is the eirp (Watts).}$$



A D T

4.1.3 TEST INSTRUMENTS

DESCRIPTION & MANUFACTURER	MODEL NO.	SERIAL NO.	DATE OF CALIBRATION	DUE DATE OF CALIBRATION
Test Receiver ROHDE & SCHWARZ	ESCI	100744	Apr. 19, 2012	Apr. 18, 2013
Spectrum Analyzer ROHDE & SCHWARZ	FSU43	101261	Dec. 17, 2012	Dec. 16, 2013
BILOG Antenna SCHWARZBECK	VULB9168	9168-472	Apr. 03, 2012	Apr. 02, 2013
HORN Antenna SCHWARZBECK	BBHA 9120 D	9120D-969	Jan. 07, 2013	Jan. 06, 2014
HORN Antenna SCHWARZBECK	BBHA 9170	9170-480	Dec. 25, 2012	Dec. 24, 2013
Loop Antenna	HFH2-Z2	100070	Jan. 31, 2012	Jan. 30, 2014
Preamplifier EMCI	EMC 012645	980115	Dec. 28, 2012	Dec. 27, 2013
Preamplifier EMCI	EMC 184045	980116	Dec. 28, 2012	Dec. 27, 2013
Preamplifier EMCI	EMC 330H	980112	Dec. 28, 2012	Dec. 27, 2013
RF signal cable HUBER+SUHNNER	SUCOFLEX 104	309219/4	Oct. 19, 2012	Oct. 18, 2013
RF signal cable HUBER+SUHNNER	SUCOFLEX 104	250130/4	Oct. 19, 2012	Oct. 18, 2013
RF signal cable Worken	RG-213	NA	Dec. 29, 2012	Dec. 28, 2013
Software	E3 6.120103	NA	NA	NA
Antenna Tower MF	MFA-440H	NA	NA	NA
Turn Table MF	MFT-201SS	NA	NA	NA
Antenna Tower & Turn Table Controller MF	MF-7802	NA	NA	NA

- NOTE:**
1. The calibration interval of the above test instruments is 12 months and the calibrations are traceable to NML/ROC and NIST/USA.
 2. The calibration interval of the loop antenna is 24 months and the calibrations are traceable to NML/ROC and NIST/USA.
 3. The test was performed in HwaYa Chamber 10.
 4. The horn antenna and HP preamplifier (model: 8449B) are used only for the measurement of emission frequency above 1GHz if tested.
 5. The FCC Site Registration No. is 690701.
 6. The IC Site Registration No. is IC 7450F-10.

4.1.4 TEST PROCEDURES

- a. The EUT was placed on the top of a rotating table 0.8 meters above the ground at a 3 meter semi-anechoic chamber. The table was rotated 360 degrees to determine the position of the highest radiation.
- b. The EUT was set 3 meters away from the interference-receiving antenna, which was mounted on the top of a variable-height antenna tower.
- c. The antenna is a broadband antenna, and its height is varied from one meter to four meters above the ground to determine the maximum value of the field strength. Both horizontal and vertical polarizations of the antenna are set to make the measurement.
- d. For each suspected emission, the EUT was arranged to its worst case and then the antenna was tuned to heights from 1 meter to 4 meters and the rotatable table was turned from 0 degrees to 360 degrees to find the maximum reading.
- e. The test-receiver system was set to Peak Detect Function and Specified Bandwidth with Maximum Hold Mode.
- f. If the emission level of the EUT in peak mode was 10dB lower than the limit specified, then testing could be stopped and the peak values of the EUT would be reported. Otherwise the emissions that did not have 10dB margin would be re-tested one by one using peak, quasi-peak or average method as specified and then reported in a data sheet.

NOTE:

1. The resolution bandwidth and video bandwidth of test receiver/spectrum analyzer is 120kHz for Peak detection (PK) and Quasi-peak detection (QP) at frequency below 1GHz.
2. The resolution bandwidth of test receiver/spectrum analyzer is 1MHz and video bandwidth is 3MHz for Peak detection at frequency above 1GHz.
3. The resolution bandwidth of test receiver/spectrum analyzer is 1MHz and the video bandwidth is 1kHz for Average detection (AV) at frequency above 1GHz.
4. All modes of operation were investigated and the worst-case emissions are reported.

4.1.5 DEVIATION FROM TEST STANDARD

No deviation.

4.1.6 TEST SETUP

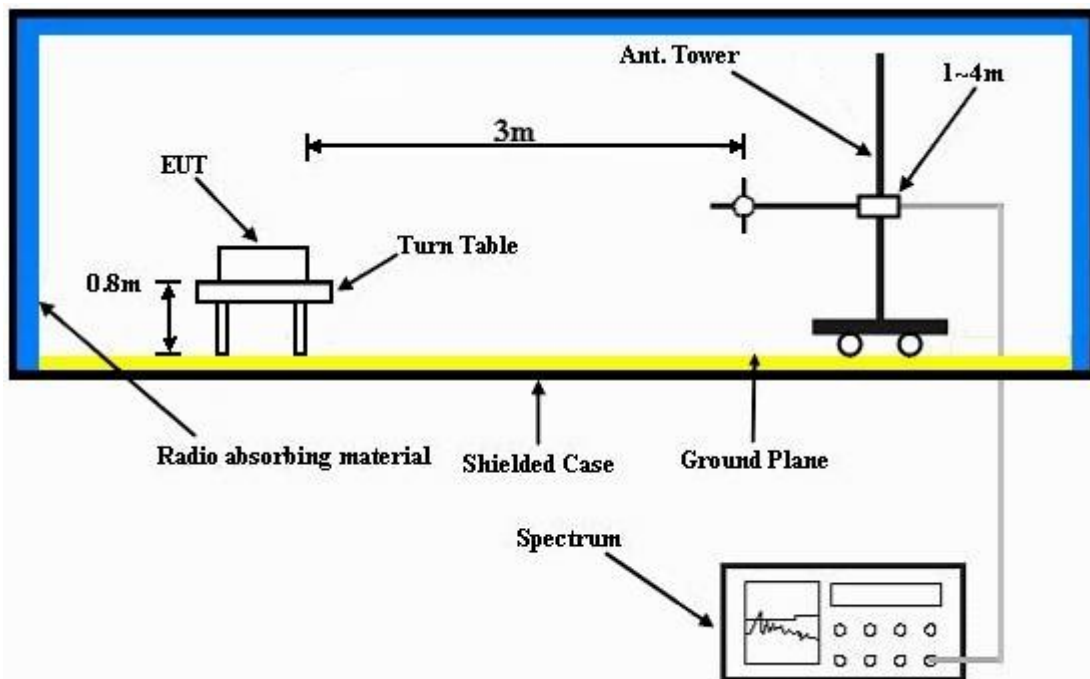

For the actual test configuration, please refer to the attached file (Test Setup Photo).

4.1.7 EUT OPERATING CONDITION

- a. Placed the EUT on a testing table.
- b. Use the software to control the EUT under transmission condition continuously at specific channel frequency.



4.1.8 TEST RESULTS

ABOVE 1GHz DATA:

802.11a

EUT TEST CONDITION		MEASUREMENT DETAIL	
CHANNEL	Channel 36	FREQUENCY RANGE	1GHz ~ 40GHz
INPUT POWER (SYSTEM)	120Vac, 60 Hz	DETECTOR FUNCTION	Peak (PK) Average (AV)
ENVIRONMENTAL CONDITIONS	25deg. C, 65%RH	TESTED BY	Kay Wu

ANTENNA POLARITY & TEST DISTANCE: HORIZONTAL AT 3 M										
FREQ. (MHz)	EMISSION LEVEL (dBuV/m)	READ LEVEL (dBuV)	LIMIT (dBuV/m)	MARGIN (dB)	ANTENNA FACTOR (dB/m)	CABLE LOSS (dB)	PREAMP FACTOR (dB)	ANTENNA HEIGHT (cm)	TABLE ANGLE (Degree)	REMARK
5044	40.91	39.67	54	-13.09	31.24	7.25	37.25	104	359	Average
5044	55.81	54.57	74	-18.19	31.24	7.25	37.25	104	359	Peak
5180	90.47	89.14			31.35	7.32	37.34	104	359	Average
5180	100.13	98.8			31.35	7.32	37.34	104	359	Peak
5430	40.95	39.06	54	-13.05	31.55	7.47	37.13	104	359	Average
5430	56.2	54.31	74	-17.8	31.55	7.47	37.13	104	359	Peak
ANTENNA POLARITY & TEST DISTANCE: VERTICAL AT 3 M										
FREQ. (MHz)	EMISSION LEVEL (dBuV/m)	READ LEVEL (dBuV)	LIMIT (dBuV/m)	MARGIN (dB)	ANTENNA FACTOR (dB/m)	CABLE LOSS (dB)	PREAMP FACTOR (dB)	ANTENNA HEIGHT (cm)	TABLE ANGLE (Degree)	REMARK
5140	41.01	39.65	54	-12.99	31.32	7.34	37.3	101	270	Average
5140	55.03	53.67	74	-18.97	31.32	7.34	37.3	101	270	Peak
5180	81.88	80.55			31.35	7.32	37.34	101	270	Average
5180	90.7	89.37			31.35	7.32	37.34	101	270	Peak
5456	40.95	38.94	54	-13.05	31.56	7.53	37.08	101	270	Average
5456	55.63	53.62	74	-18.37	31.56	7.53	37.08	101	270	Peak

REMARKS: 5180MHz: Fundamental frequency.



EUT TEST CONDITION		MEASUREMENT DETAIL	
CHANNEL	Channel 44	FREQUENCY RANGE	1GHz ~ 40GHz
INPUT POWER (SYSTEM)	120Vac, 60 Hz	DETECTOR FUNCTION	Peak (PK) Average (AV)
ENVIRONMENTAL CONDITIONS	25deg. C, 65%RH	TESTED BY	Kay Wu

ANTENNA POLARITY & TEST DISTANCE: HORIZONTAL AT 3 M										
FREQ. (MHz)	EMISSION LEVEL (dBuV/m)	READ LEVEL (dBuV)	LIMIT (dBuV/m)	MARGIN (dB)	ANTENNA FACTOR (dB/m)	CABLE LOSS (dB)	PREAMP FACTOR (dB)	ANTENNA HEIGHT (cm)	TABLE ANGLE (Degree)	REMARK
5080	40.96	39.66	54	-13.04	31.27	7.3	37.27	103	357	Average
5080	55.73	54.43	74	-18.27	31.27	7.3	37.27	103	357	Peak
5220	90.75	89.42			31.37	7.32	37.36	103	357	Average
5220	101.87	100.54			31.37	7.32	37.36	103	357	Peak
5442	40.98	39.09	54	-13.02	31.55	7.47	37.13	103	357	Average
5442	55.9	54.01	74	-18.1	31.55	7.47	37.13	103	357	Peak
ANTENNA POLARITY & TEST DISTANCE: VERTICAL AT 3 M										
FREQ. (MHz)	EMISSION LEVEL (dBuV/m)	READ LEVEL (dBuV)	LIMIT (dBuV/m)	MARGIN (dB)	ANTENNA FACTOR (dB/m)	CABLE LOSS (dB)	PREAMP FACTOR (dB)	ANTENNA HEIGHT (cm)	TABLE ANGLE (Degree)	REMARK
5140	41.22	39.86	54	-12.78	31.32	7.34	37.3	101	256	Average
5140	55.55	54.19	74	-18.45	31.32	7.34	37.3	101	256	Peak
5220	82.69	81.36			31.37	7.32	37.36	101	256	Average
5220	92.26	90.93			31.37	7.32	37.36	101	256	Peak
5430	41.06	39.17	54	-12.94	31.55	7.47	37.13	101	256	Average
5430	55.77	53.88	74	-18.23	31.55	7.47	37.13	101	256	Peak

REMARKS: 5220MHz: Fundamental frequency.



EUT TEST CONDITION		MEASUREMENT DETAIL	
CHANNEL	Channel 48	FREQUENCY RANGE	1GHz ~ 40GHz
INPUT POWER (SYSTEM)	120Vac, 60 Hz	DETECTOR FUNCTION	Peak (PK) Average (AV)
ENVIRONMENTAL CONDITIONS	25deg. C, 65%RH	TESTED BY	Kay Wu

ANTENNA POLARITY & TEST DISTANCE: HORIZONTAL AT 3 M										
FREQ. (MHz)	EMISSION LEVEL (dBuV/m)	READ LEVEL (dBuV)	LIMIT (dBuV/m)	MARGIN (dB)	ANTENNA FACTOR (dB/m)	CABLE LOSS (dB)	PREAMP FACTOR (dB)	ANTENNA HEIGHT (cm)	TABLE ANGLE (Degree)	REMARK
5058	40.85	39.6	54	-13.15	31.25	7.25	37.25	102	357	Average
5058	55.48	54.23	74	-18.52	31.25	7.25	37.25	102	357	Peak
5240	90.41	89			31.39	7.34	37.32	102	357	Average
5240	100.17	98.76			31.39	7.34	37.32	102	357	Peak
5450	41.32	39.31	54	-12.68	31.56	7.53	37.08	102	357	Average
5450	56.09	54.08	74	-17.91	31.56	7.53	37.08	102	357	Peak
ANTENNA POLARITY & TEST DISTANCE: VERTICAL AT 3 M										
FREQ. (MHz)	EMISSION LEVEL (dBuV/m)	READ LEVEL (dBuV)	LIMIT (dBuV/m)	MARGIN (dB)	ANTENNA FACTOR (dB/m)	CABLE LOSS (dB)	PREAMP FACTOR (dB)	ANTENNA HEIGHT (cm)	TABLE ANGLE (Degree)	REMARK
5090	41.06	39.75	54	-12.94	31.28	7.3	37.27	101	256	Average
5090	55.29	53.98	74	-18.71	31.28	7.3	37.27	101	256	Peak
5240	82.56	81.15			31.39	7.34	37.32	101	256	Average
5240	91.27	89.86			31.39	7.34	37.32	101	256	Peak
5390	41.1	39.37	54	-12.9	31.51	7.4	37.18	101	256	Average
5390	56.71	54.98	74	-17.29	31.51	7.4	37.18	101	256	Peak

REMARKS: 5240MHz: Fundamental frequency.



A D T

EUT TEST CONDITION		MEASUREMENT DETAIL	
CHANNEL	Channel 52	FREQUENCY RANGE	1GHz ~ 40GHz
INPUT POWER (SYSTEM)	120Vac, 60 Hz	DETECTOR FUNCTION	Peak (PK) Average (AV)
ENVIRONMENTAL CONDITIONS	25deg. C, 65%RH	TESTED BY	Kay Wu

ANTENNA POLARITY & TEST DISTANCE: HORIZONTAL AT 3 M										
FREQ. (MHz)	EMISSION LEVEL (dBuV/m)	READ LEVEL (dBuV)	LIMIT (dBuV/m)	MARGIN (dB)	ANTENNA FACTOR (dB/m)	CABLE LOSS (dB)	PREAMP FACTOR (dB)	ANTENNA HEIGHT (cm)	TABLE ANGLE (Degree)	REMARK
5146	40.85	39.52	54	-13.15	31.32	7.33	37.32	100	360	Average
5146	55.14	53.81	74	-18.86	31.32	7.33	37.32	100	360	Peak
5260	90.9	89.4			31.41	7.36	37.27	100	360	Average
5260	100.5	99			31.41	7.36	37.27	100	360	Peak
5406	41.21	39.47	54	-12.79	31.52	7.4	37.18	100	360	Average
5406	55.11	53.37	74	-18.89	31.52	7.4	37.18	100	360	Peak
ANTENNA POLARITY & TEST DISTANCE: VERTICAL AT 3 M										
FREQ. (MHz)	EMISSION LEVEL (dBuV/m)	READ LEVEL (dBuV)	LIMIT (dBuV/m)	MARGIN (dB)	ANTENNA FACTOR (dB/m)	CABLE LOSS (dB)	PREAMP FACTOR (dB)	ANTENNA HEIGHT (cm)	TABLE ANGLE (Degree)	REMARK
5094	40.91	39.56	54	-13.09	31.28	7.35	37.28	100	257	Average
5094	55.01	53.66	74	-18.99	31.28	7.35	37.28	100	257	Peak
5260	82.66	81.16			31.41	7.36	37.27	100	257	Average
5260	92.43	90.93			31.41	7.36	37.27	100	257	Peak
5436	41.19	39.3	54	-12.81	31.55	7.47	37.13	100	257	Average
5436	56.17	54.28	74	-17.83	31.55	7.47	37.13	100	257	Peak

REMARKS: 5260MHz: Fundamental frequency.



EUT TEST CONDITION		MEASUREMENT DETAIL	
CHANNEL	Channel 60	FREQUENCY RANGE	1GHz ~ 40GHz
INPUT POWER (SYSTEM)	120Vac, 60 Hz	DETECTOR FUNCTION	Peak (PK) Average (AV)
ENVIRONMENTAL CONDITIONS	25deg. C, 65%RH	TESTED BY	Kay Wu

ANTENNA POLARITY & TEST DISTANCE: HORIZONTAL AT 3 M										
FREQ. (MHz)	EMISSION LEVEL (dBuV/m)	READ LEVEL (dBuV)	LIMIT (dBuV/m)	MARGIN (dB)	ANTENNA FACTOR (dB/m)	CABLE LOSS (dB)	PREAMP FACTOR (dB)	ANTENNA HEIGHT (cm)	TABLE ANGLE (Degree)	REMARK
5030	40.61	39.43	54	-13.39	31.23	7.19	37.24	101	357	Average
5030	54.95	53.77	74	-19.05	31.23	7.19	37.24	101	357	Peak
5300	91.55	89.9			31.44	7.4	37.19	101	357	Average
5300	100.43	98.78			31.44	7.4	37.19	101	357	Peak
5424	41.96	40.21	54	-12.04	31.53	7.4	37.18	101	357	Average
5424	55.71	53.96	74	-18.29	31.53	7.4	37.18	101	357	Peak
ANTENNA POLARITY & TEST DISTANCE: VERTICAL AT 3 M										
FREQ. (MHz)	EMISSION LEVEL (dBuV/m)	READ LEVEL (dBuV)	LIMIT (dBuV/m)	MARGIN (dB)	ANTENNA FACTOR (dB/m)	CABLE LOSS (dB)	PREAMP FACTOR (dB)	ANTENNA HEIGHT (cm)	TABLE ANGLE (Degree)	REMARK
5084	40.81	39.51	54	-13.19	31.27	7.3	37.27	100	256	Average
5084	55.06	53.76	74	-18.94	31.27	7.3	37.27	100	256	Peak
5300	83.3	81.65			31.44	7.4	37.19	100	256	Average
5300	91.95	90.3			31.44	7.4	37.19	100	256	Peak
5456	41.22	39.21	54	-12.78	31.56	7.53	37.08	100	256	Average
5456	55.18	53.17	74	-18.82	31.56	7.53	37.08	100	256	Peak

REMARKS: 5300MHz: Fundamental frequency.



EUT TEST CONDITION		MEASUREMENT DETAIL	
CHANNEL	Channel 64	FREQUENCY RANGE	1GHz ~ 40GHz
INPUT POWER (SYSTEM)	120Vac, 60 Hz	DETECTOR FUNCTION	Peak (PK) Average (AV)
ENVIRONMENTAL CONDITIONS	25deg. C, 65%RH	TESTED BY	Kay Wu

ANTENNA POLARITY & TEST DISTANCE: HORIZONTAL AT 3 M										
FREQ. (MHz)	EMISSION LEVEL (dBuV/m)	READ LEVEL (dBuV)	LIMIT (dBuV/m)	MARGIN (dB)	ANTENNA FACTOR (dB/m)	CABLE LOSS (dB)	PREAMP FACTOR (dB)	ANTENNA HEIGHT (cm)	TABLE ANGLE (Degree)	REMARK
5076	41.06	39.76	54	-12.94	31.27	7.3	37.27	100	356	Average
5076	55.52	54.22	74	-18.48	31.27	7.3	37.27	100	356	Peak
5320	91.29	89.63			31.45	7.4	37.19	100	356	Average
5320	101.13	99.47			31.45	7.4	37.19	100	356	Peak
5420	42.1	40.35	54	-11.9	31.53	7.4	37.18	100	356	Average
5420	56	54.25	74	-18	31.53	7.4	37.18	100	356	Peak
ANTENNA POLARITY & TEST DISTANCE: VERTICAL AT 3 M										
FREQ. (MHz)	EMISSION LEVEL (dBuV/m)	READ LEVEL (dBuV)	LIMIT (dBuV/m)	MARGIN (dB)	ANTENNA FACTOR (dB/m)	CABLE LOSS (dB)	PREAMP FACTOR (dB)	ANTENNA HEIGHT (cm)	TABLE ANGLE (Degree)	REMARK
5062	40.61	39.36	54	-13.39	31.25	7.25	37.25	110	257	Average
5062	55.3	54.05	74	-18.7	31.25	7.25	37.25	110	257	Peak
5320	83.06	81.4			31.45	7.4	37.19	110	257	Average
5320	92.43	90.77			31.45	7.4	37.19	110	257	Peak
5388	40.88	39.15	54	-13.12	31.51	7.4	37.18	110	257	Average
5388	55.73	54	74	-18.27	31.51	7.4	37.18	110	257	Peak

REMARKS: 5320MHz: Fundamental frequency.



A D T

EUT TEST CONDITION		MEASUREMENT DETAIL	
CHANNEL	Channel 100	FREQUENCY RANGE	1GHz ~ 40GHz
INPUT POWER (SYSTEM)	120Vac, 60 Hz	DETECTOR FUNCTION	Peak (PK) Average (AV)
ENVIRONMENTAL CONDITIONS	25deg. C, 65%RH	TESTED BY	Kay Wu

ANTENNA POLARITY & TEST DISTANCE: HORIZONTAL AT 3 M										
FREQ. (MHz)	EMISSION LEVEL (dBuV/m)	READ LEVEL (dBuV)	LIMIT (dBuV/m)	MARGIN (dB)	ANTENNA FACTOR (dB/m)	CABLE LOSS (dB)	PREAMP FACTOR (dB)	ANTENNA HEIGHT (cm)	TABLE ANGLE (Degree)	REMARK
5352	40.83	39.13	54	-13.17	31.48	7.4	37.18	101	316	Average
5352	55.66	53.96	74	-18.34	31.48	7.4	37.18	101	316	Peak
5470	55.45	53.43	68.3	-12.85	31.57	7.53	37.08	101	316	Peak
5500	85.08	82.92			31.6	7.59	37.03	101	316	Average
5500	94.39	92.23			31.6	7.59	37.03	101	316	Peak
5725	56.57	54.33	68.3	-11.73	31.96	7.71	37.43	101	316	Peak
ANTENNA POLARITY & TEST DISTANCE: VERTICAL AT 3 M										
FREQ. (MHz)	EMISSION LEVEL (dBuV/m)	READ LEVEL (dBuV)	LIMIT (dBuV/m)	MARGIN (dB)	ANTENNA FACTOR (dB/m)	CABLE LOSS (dB)	PREAMP FACTOR (dB)	ANTENNA HEIGHT (cm)	TABLE ANGLE (Degree)	REMARK
5418	42.07	40.32	54	-11.93	31.53	7.4	37.18	100	0	Average
5418	56.38	54.63	74	-17.62	31.53	7.4	37.18	100	0	Peak
5470	54.6	52.58	68.3	-13.7	31.57	7.53	37.08	100	0	Peak
5500	93.46	91.3			31.6	7.59	37.03	100	0	Average
5500	102.29	100.13			31.6	7.59	37.03	100	0	Peak
5725	54.6	52.36	68.3	-13.7	31.96	7.71	37.43	100	0	Peak

REMARKS:

1. 5500MHz: Fundamental frequency.
2. 5470MHz & 5725MHz: Out of restricted band



A D T

EUT TEST CONDITION		MEASUREMENT DETAIL	
CHANNEL	Channel 116	FREQUENCY RANGE	1GHz ~ 40GHz
INPUT POWER (SYSTEM)	120Vac, 60 Hz	DETECTOR FUNCTION	Peak (PK) Average (AV)
ENVIRONMENTAL CONDITIONS	25deg. C, 65%RH	TESTED BY	Kay Wu

ANTENNA POLARITY & TEST DISTANCE: HORIZONTAL AT 3 M										
FREQ. (MHz)	EMISSION LEVEL (dBuV/m)	READ LEVEL (dBuV)	LIMIT (dBuV/m)	MARGIN (dB)	ANTENNA FACTOR (dB/m)	CABLE LOSS (dB)	PREAMP FACTOR (dB)	ANTENNA HEIGHT (cm)	TABLE ANGLE (Degree)	REMARK
5440	41.08	39.19	54	-12.92	31.55	7.47	37.13	100	328	Average
5440	56.19	54.3	74	-17.81	31.55	7.47	37.13	100	328	Peak
5470	55.74	53.72	68.3	-12.56	31.57	7.53	37.08	100	328	Peak
5580	84.27	82.15			31.71	7.57	37.16	100	328	Average
5580	94.62	92.5			31.71	7.57	37.16	100	328	Peak
5725	55.7	53.46	68.3	-12.6	31.96	7.71	37.43	100	328	Peak
ANTENNA POLARITY & TEST DISTANCE: VERTICAL AT 3 M										
FREQ. (MHz)	EMISSION LEVEL (dBuV/m)	READ LEVEL (dBuV)	LIMIT (dBuV/m)	MARGIN (dB)	ANTENNA FACTOR (dB/m)	CABLE LOSS (dB)	PREAMP FACTOR (dB)	ANTENNA HEIGHT (cm)	TABLE ANGLE (Degree)	REMARK
5440	40.89	39	54	-13.11	31.55	7.47	37.13	100	0	Average
5440	56.93	55.04	74	-17.07	31.55	7.47	37.13	100	0	Peak
5470	55.06	53.04	68.3	-13.24	31.57	7.53	37.08	100	0	Peak
5580	93.45	91.33			31.71	7.57	37.16	100	0	Average
5580	103.43	101.31			31.71	7.57	37.16	100	0	Peak
5725	54.89	52.65	68.3	-13.41	31.96	7.71	37.43	100	0	Peak

REMARKS:

1. 5580MHz: Fundamental frequency.
2. 5470MHz & 5725MHz: Out of restricted band



EUT TEST CONDITION		MEASUREMENT DETAIL	
CHANNEL	Channel 140	FREQUENCY RANGE	1GHz ~ 40GHz
INPUT POWER (SYSTEM)	120Vac, 60 Hz	DETECTOR FUNCTION	Peak (PK) Average (AV)
ENVIRONMENTAL CONDITIONS	25deg. C, 65%RH	TESTED BY	Kay Wu

ANTENNA POLARITY & TEST DISTANCE: HORIZONTAL AT 3 M										
FREQ. (MHz)	EMISSION LEVEL (dBuV/m)	READ LEVEL (dBuV)	LIMIT (dBuV/m)	MARGIN (dB)	ANTENNA FACTOR (dB/m)	CABLE LOSS (dB)	PREAMP FACTOR (dB)	ANTENNA HEIGHT (cm)	TABLE ANGLE (Degree)	REMARK
5428	41.1	39.23	54	-12.9	31.53	7.47	37.13	100	329	Average
5428	56.33	54.46	74	-17.67	31.53	7.47	37.13	100	329	Peak
5470	54.76	52.74	68.3	-13.54	31.57	7.53	37.08	100	329	Peak
5700	85.26	83.07			31.9	7.69	37.4	100	329	Average
5700	95.7	93.51			31.9	7.69	37.4	100	329	Peak
5725	57.55	55.31	68.3	-10.75	31.96	7.71	37.43	100	329	Peak
ANTENNA POLARITY & TEST DISTANCE: VERTICAL AT 3 M										
FREQ. (MHz)	EMISSION LEVEL (dBuV/m)	READ LEVEL (dBuV)	LIMIT (dBuV/m)	MARGIN (dB)	ANTENNA FACTOR (dB/m)	CABLE LOSS (dB)	PREAMP FACTOR (dB)	ANTENNA HEIGHT (cm)	TABLE ANGLE (Degree)	REMARK
5426	40.9	39.03	54	-13.1	31.53	7.47	37.13	113	297	Average
5426	56.13	54.26	74	-17.87	31.53	7.47	37.13	113	297	Peak
5470	54.58	52.56	68.3	-13.72	31.57	7.53	37.08	113	297	Peak
5700	93.31	91.12			31.9	7.69	37.4	113	297	Average
5700	102.93	100.74			31.9	7.69	37.4	113	297	Peak
5725	66.99	65.75	68.3	-1.31	31.96	7.71	37.43	113	297	Peak

REMARKS:

- 5700MHz: Fundamental frequency.
- 5470MHz & 5725MHz: Out of restricted band



A D T

802.11n (20MHz)

EUT TEST CONDITION		MEASUREMENT DETAIL	
CHANNEL	Channel 36	FREQUENCY RANGE	1GHz ~ 40GHz
INPUT POWER (SYSTEM)	120Vac, 60 Hz	DETECTOR FUNCTION	Peak (PK) Average (AV)
ENVIRONMENTAL CONDITIONS	25deg. C, 65%RH	TESTED BY	Kay Wu

ANTENNA POLARITY & TEST DISTANCE: HORIZONTAL AT 3 M										
FREQ. (MHz)	EMISSION LEVEL (dBuV/m)	READ LEVEL (dBuV)	LIMIT (dBuV/m)	MARGIN (dB)	ANTENNA FACTOR (dB/m)	CABLE LOSS (dB)	PREAMP FACTOR (dB)	ANTENNA HEIGHT (cm)	TABLE ANGLE (Degree)	REMARK
5130	40.08	38.73	54	-13.92	31.31	7.34	37.3	100	51	Average
5130	55.06	53.71	74	-18.94	31.31	7.34	37.3	100	51	Peak
5180	85.92	84.59			31.35	7.32	37.34	100	51	Average
5180	95.29	93.96			31.35	7.32	37.34	100	51	Peak
5446	39.99	38.09	54	-14.01	31.56	7.47	37.13	100	51	Average
5446	55.52	53.62	74	-18.48	31.56	7.47	37.13	100	51	Peak

ANTENNA POLARITY & TEST DISTANCE: VERTICAL AT 3 M										
FREQ. (MHz)	EMISSION LEVEL (dBuV/m)	READ LEVEL (dBuV)	LIMIT (dBuV/m)	MARGIN (dB)	ANTENNA FACTOR (dB/m)	CABLE LOSS (dB)	PREAMP FACTOR (dB)	ANTENNA HEIGHT (cm)	TABLE ANGLE (Degree)	REMARK
5048	39.36	38.12	54	-14.64	31.24	7.25	37.25	100	10	Average
5048	56.18	54.94	74	-17.82	31.24	7.25	37.25	100	10	Peak
5180	79.03	77.7			31.35	7.32	37.34	100	10	Average
5180	88.18	86.85			31.35	7.32	37.34	100	10	Peak
5454	39.91	37.9	54	-14.09	31.56	7.53	37.08	100	10	Average
5454	55.36	53.35	74	-18.64	31.56	7.53	37.08	100	10	Peak

REMARKS: 5180MHz: Fundamental frequency.



A D T

EUT TEST CONDITION		MEASUREMENT DETAIL	
CHANNEL	Channel 44	FREQUENCY RANGE	1GHz ~ 40GHz
INPUT POWER (SYSTEM)	120Vac, 60 Hz	DETECTOR FUNCTION	Peak (PK) Average (AV)
ENVIRONMENTAL CONDITIONS	25deg. C, 65%RH	TESTED BY	Kay Wu

ANTENNA POLARITY & TEST DISTANCE: HORIZONTAL AT 3 M										
FREQ. (MHz)	EMISSION LEVEL (dBuV/m)	READ LEVEL (dBuV)	LIMIT (dBuV/m)	MARGIN (dB)	ANTENNA FACTOR (dB/m)	CABLE LOSS (dB)	PREAMP FACTOR (dB)	ANTENNA HEIGHT (cm)	TABLE ANGLE (Degree)	REMARK
5118	39.56	38.2	54	-14.44	31.29	7.35	37.28	103	15	Average
5118	55.2	53.84	74	-18.8	31.29	7.35	37.28	103	15	Peak
5220	87.17	85.84			31.37	7.32	37.36	103	15	Average
5220	96.54	95.21			31.37	7.32	37.36	103	15	Peak
5460	39.99	37.98	54	-14.01	31.56	7.53	37.08	103	15	Average
5460	56.1	54.09	74	-17.9	31.56	7.53	37.08	103	15	Peak
ANTENNA POLARITY & TEST DISTANCE: VERTICAL AT 3 M										
FREQ. (MHz)	EMISSION LEVEL (dBuV/m)	READ LEVEL (dBuV)	LIMIT (dBuV/m)	MARGIN (dB)	ANTENNA FACTOR (dB/m)	CABLE LOSS (dB)	PREAMP FACTOR (dB)	ANTENNA HEIGHT (cm)	TABLE ANGLE (Degree)	REMARK
5028	39.36	38.18	54	-14.64	31.23	7.19	37.24	100	335	Average
5028	55.6	54.42	74	-18.4	31.23	7.19	37.24	100	335	Peak
5220	79.69	78.36			31.37	7.32	37.36	100	335	Average
5220	89.09	87.76			31.37	7.32	37.36	100	335	Peak
5434	39.83	37.94	54	-14.17	31.55	7.47	37.13	100	335	Average
5434	55.21	53.32	74	-18.79	31.55	7.47	37.13	100	335	Peak

REMARKS: 5220MHz: Fundamental frequency.



A D T

EUT TEST CONDITION		MEASUREMENT DETAIL	
CHANNEL	Channel 48	FREQUENCY RANGE	1GHz ~ 40GHz
INPUT POWER (SYSTEM)	120Vac, 60 Hz	DETECTOR FUNCTION	Peak (PK) Average (AV)
ENVIRONMENTAL CONDITIONS	25deg. C, 65%RH	TESTED BY	Kay Wu

ANTENNA POLARITY & TEST DISTANCE: HORIZONTAL AT 3 M										
FREQ. (MHz)	EMISSION LEVEL (dBuV/m)	READ LEVEL (dBuV)	LIMIT (dBuV/m)	MARGIN (dB)	ANTENNA FACTOR (dB/m)	CABLE LOSS (dB)	PREAMP FACTOR (dB)	ANTENNA HEIGHT (cm)	TABLE ANGLE (Degree)	REMARK
5148	39.61	38.28	54	-14.39	31.32	7.33	37.32	102	37	Average
5148	55.8	54.47	74	-18.2	31.32	7.33	37.32	102	37	Peak
5240	87.59	86.18			31.39	7.34	37.32	102	37	Average
5240	97.67	96.26			31.39	7.34	37.32	102	37	Peak
5436	39.93	38.04	54	-14.07	31.55	7.47	37.13	102	37	Average
5436	56.5	54.61	74	-17.5	31.55	7.47	37.13	102	37	Peak
ANTENNA POLARITY & TEST DISTANCE: VERTICAL AT 3 M										
FREQ. (MHz)	EMISSION LEVEL (dBuV/m)	READ LEVEL (dBuV)	LIMIT (dBuV/m)	MARGIN (dB)	ANTENNA FACTOR (dB/m)	CABLE LOSS (dB)	PREAMP FACTOR (dB)	ANTENNA HEIGHT (cm)	TABLE ANGLE (Degree)	REMARK
5124	39.6	38.25	54	-14.4	31.31	7.34	37.3	103	342	Average
5124	55.7	54.35	74	-18.3	31.31	7.34	37.3	103	342	Peak
5240	83.14	81.73			31.39	7.34	37.32	103	342	Average
5240	92.65	91.24			31.39	7.34	37.32	103	342	Peak
5428	39.9	38.03	54	-14.1	31.53	7.47	37.13	103	342	Average
5428	56.22	54.35	74	-17.78	31.53	7.47	37.13	103	342	Peak

REMARKS: 5240MHz: Fundamental frequency.



A D T

EUT TEST CONDITION		MEASUREMENT DETAIL	
CHANNEL	Channel 52	FREQUENCY RANGE	1GHz ~ 40GHz
INPUT POWER (SYSTEM)	120Vac, 60 Hz	DETECTOR FUNCTION	Peak (PK) Average (AV)
ENVIRONMENTAL CONDITIONS	25deg. C, 65%RH	TESTED BY	Kay Wu

ANTENNA POLARITY & TEST DISTANCE: HORIZONTAL AT 3 M										
FREQ. (MHz)	EMISSION LEVEL (dBuV/m)	READ LEVEL (dBuV)	LIMIT (dBuV/m)	MARGIN (dB)	ANTENNA FACTOR (dB/m)	CABLE LOSS (dB)	PREAMP FACTOR (dB)	ANTENNA HEIGHT (cm)	TABLE ANGLE (Degree)	REMARK
5134	39.57	38.22	54	-14.43	31.31	7.34	37.3	100	358	Average
5134	55.87	54.52	74	-18.13	31.31	7.34	37.3	100	358	Peak
5260	87.33	85.83			31.41	7.36	37.27	100	358	Average
5260	96.88	95.38			31.41	7.36	37.27	100	358	Peak
5370	39.77	38.06	54	-14.23	31.49	7.4	37.18	100	358	Average
5370	56.26	54.55	74	-17.74	31.49	7.4	37.18	100	358	Peak
ANTENNA POLARITY & TEST DISTANCE: VERTICAL AT 3 M										
FREQ. (MHz)	EMISSION LEVEL (dBuV/m)	READ LEVEL (dBuV)	LIMIT (dBuV/m)	MARGIN (dB)	ANTENNA FACTOR (dB/m)	CABLE LOSS (dB)	PREAMP FACTOR (dB)	ANTENNA HEIGHT (cm)	TABLE ANGLE (Degree)	REMARK
5092	39.45	38.14	54	-14.55	31.28	7.3	37.27	100	257	Average
5092	54.95	53.64	74	-19.05	31.28	7.3	37.27	100	257	Peak
5260	80.24	78.74			31.41	7.36	37.27	100	257	Average
5260	89.83	88.33			31.41	7.36	37.27	100	257	Peak
5428	39.83	37.96	54	-14.17	31.53	7.47	37.13	100	257	Average
5428	55.57	53.7	74	-18.43	31.53	7.47	37.13	100	257	Peak

REMARKS: 5260MHz: Fundamental frequency.



A D T

EUT TEST CONDITION		MEASUREMENT DETAIL	
CHANNEL	Channel 60	FREQUENCY RANGE	1GHz ~ 40GHz
INPUT POWER (SYSTEM)	120Vac, 60 Hz	DETECTOR FUNCTION	Peak (PK) Average (AV)
ENVIRONMENTAL CONDITIONS	25deg. C, 65%RH	TESTED BY	Kay Wu

ANTENNA POLARITY & TEST DISTANCE: HORIZONTAL AT 3 M										
FREQ. (MHz)	EMISSION LEVEL (dBuV/m)	READ LEVEL (dBuV)	LIMIT (dBuV/m)	MARGIN (dB)	ANTENNA FACTOR (dB/m)	CABLE LOSS (dB)	PREAMP FACTOR (dB)	ANTENNA HEIGHT (cm)	TABLE ANGLE (Degree)	REMARK
5038	39.31	38.12	54	-14.69	31.24	7.19	37.24	100	355	Average
5038	55.83	54.64	74	-18.17	31.24	7.19	37.24	100	355	Peak
5300	89.05	87.4			31.44	7.4	37.19	100	355	Average
5300	98.42	96.77			31.44	7.4	37.19	100	355	Peak
5364	41.28	39.57	54	-12.72	31.49	7.4	37.18	100	355	Average
5364	56.09	54.38	74	-17.91	31.49	7.4	37.18	100	355	Peak
ANTENNA POLARITY & TEST DISTANCE: VERTICAL AT 3 M										
FREQ. (MHz)	EMISSION LEVEL (dBuV/m)	READ LEVEL (dBuV)	LIMIT (dBuV/m)	MARGIN (dB)	ANTENNA FACTOR (dB/m)	CABLE LOSS (dB)	PREAMP FACTOR (dB)	ANTENNA HEIGHT (cm)	TABLE ANGLE (Degree)	REMARK
5144	39.58	38.25	54	-14.42	31.32	7.33	37.32	102	343	Average
5144	55.78	54.45	74	-18.22	31.32	7.33	37.32	102	343	Peak
5300	82.97	81.32			31.44	7.4	37.19	102	343	Average
5300	92.49	90.84			31.44	7.4	37.19	102	343	Peak
5392	39.77	38.04	54	-14.23	31.51	7.4	37.18	102	343	Average
5392	56.46	54.73	74	-17.54	31.51	7.4	37.18	102	343	Peak

REMARKS: 5300MHz: Fundamental frequency.



A D T

EUT TEST CONDITION		MEASUREMENT DETAIL	
CHANNEL	Channel 64	FREQUENCY RANGE	1GHz ~ 40GHz
INPUT POWER (SYSTEM)	120Vac, 60 Hz	DETECTOR FUNCTION	Peak (PK) Average (AV)
ENVIRONMENTAL CONDITIONS	25deg. C, 65%RH	TESTED BY	Kay Wu

ANTENNA POLARITY & TEST DISTANCE: HORIZONTAL AT 3 M										
FREQ. (MHz)	EMISSION LEVEL (dBuV/m)	READ LEVEL (dBuV)	LIMIT (dBuV/m)	MARGIN (dB)	ANTENNA FACTOR (dB/m)	CABLE LOSS (dB)	PREAMP FACTOR (dB)	ANTENNA HEIGHT (cm)	TABLE ANGLE (Degree)	REMARK
5034	39.62	38.44	54	-14.38	31.23	7.19	37.24	100	354	Average
5034	56.33	55.15	74	-17.67	31.23	7.19	37.24	100	354	Peak
5320	88.94	87.28			31.45	7.4	37.19	100	354	Average
5320	98.79	97.13			31.45	7.4	37.19	100	354	Peak
5460	41.4	39.39	54	-12.6	31.56	7.53	37.08	100	354	Average
5460	56.91	54.9	74	-17.09	31.56	7.53	37.08	100	354	Peak
ANTENNA POLARITY & TEST DISTANCE: VERTICAL AT 3 M										
FREQ. (MHz)	EMISSION LEVEL (dBuV/m)	READ LEVEL (dBuV)	LIMIT (dBuV/m)	MARGIN (dB)	ANTENNA FACTOR (dB/m)	CABLE LOSS (dB)	PREAMP FACTOR (dB)	ANTENNA HEIGHT (cm)	TABLE ANGLE (Degree)	REMARK
5082	39.65	38.35	54	-14.35	31.27	7.3	37.27	100	342	Average
5082	56.75	55.45	74	-17.25	31.27	7.3	37.27	100	342	Peak
5320	82.44	80.78			31.45	7.4	37.19	100	342	Average
5320	91.98	90.32			31.45	7.4	37.19	100	342	Peak
5442	39.99	38.1	54	-14.01	31.55	7.47	37.13	100	342	Average
5442	56.38	54.49	74	-17.62	31.55	7.47	37.13	100	342	Peak

REMARKS: 5320MHz: Fundamental frequency.



EUT TEST CONDITION		MEASUREMENT DETAIL	
CHANNEL	Channel 100	FREQUENCY RANGE	1GHz ~ 40GHz
INPUT POWER (SYSTEM)	120Vac, 60 Hz	DETECTOR FUNCTION	Peak (PK) Average (AV)
ENVIRONMENTAL CONDITIONS	25deg. C, 65%RH	TESTED BY	Kay Wu

ANTENNA POLARITY & TEST DISTANCE: HORIZONTAL AT 3 M										
FREQ. (MHz)	EMISSION LEVEL (dBuV/m)	READ LEVEL (dBuV)	LIMIT (dBuV/m)	MARGIN (dB)	ANTENNA FACTOR (dB/m)	CABLE LOSS (dB)	PREAMP FACTOR (dB)	ANTENNA HEIGHT (cm)	TABLE ANGLE (Degree)	REMARK
5432	40.37	38.48	54	-13.63	31.55	7.47	37.13	101	314	Average
5432	56.23	54.34	74	-17.77	31.55	7.47	37.13	101	314	Peak
5470	54.24	52.22	68.3	-14.06	31.57	7.53	37.08	101	314	Peak
5500	84.68	82.52			31.6	7.59	37.03	101	314	Average
5500	94.29	92.13			31.6	7.59	37.03	101	314	Peak
5725	56.06	53.82	68.3	-12.24	31.96	7.71	37.43	101	314	Peak
ANTENNA POLARITY & TEST DISTANCE: VERTICAL AT 3 M										
FREQ. (MHz)	EMISSION LEVEL (dBuV/m)	READ LEVEL (dBuV)	LIMIT (dBuV/m)	MARGIN (dB)	ANTENNA FACTOR (dB/m)	CABLE LOSS (dB)	PREAMP FACTOR (dB)	ANTENNA HEIGHT (cm)	TABLE ANGLE (Degree)	REMARK
5434	42.27	40.38	54	-11.73	31.55	7.47	37.13	100	335	Average
5434	55.82	53.93	74	-18.18	31.55	7.47	37.13	100	335	Peak
5470	56.63	54.61	68.3	-11.67	31.57	7.53	37.08	100	335	Peak
5500	92.78	90.62			31.6	7.59	37.03	100	335	Average
5500	102.37	100.21			31.6	7.59	37.03	100	335	Peak
5725	55.1	52.86	68.3	-13.2	31.96	7.71	37.43	100	335	Peak

REMARKS:

- 5500MHz: Fundamental frequency.
- 5470MHz & 5725MHz: Out of restricted band



A D T

EUT TEST CONDITION		MEASUREMENT DETAIL	
CHANNEL	Channel 116	FREQUENCY RANGE	1GHz ~ 40GHz
INPUT POWER (SYSTEM)	120Vac, 60 Hz	DETECTOR FUNCTION	Peak (PK) Average (AV)
ENVIRONMENTAL CONDITIONS	25deg. C, 65%RH	TESTED BY	Kay Wu

ANTENNA POLARITY & TEST DISTANCE: HORIZONTAL AT 3 M										
FREQ. (MHz)	EMISSION LEVEL (dBuV/m)	READ LEVEL (dBuV)	LIMIT (dBuV/m)	MARGIN (dB)	ANTENNA FACTOR (dB/m)	CABLE LOSS (dB)	PREAMP FACTOR (dB)	ANTENNA HEIGHT (cm)	TABLE ANGLE (Degree)	REMARK
5410	39.85	38.11	54	-14.15	31.52	7.4	37.18	100	314	Average
5410	55.39	53.65	74	-18.61	31.52	7.4	37.18	100	314	Peak
5470	54.14	52.12	68.3	-14.16	31.57	7.53	37.08	100	314	Peak
5580	84.66	82.54			31.71	7.57	37.16	100	314	Average
5580	94.55	92.43			31.71	7.57	37.16	100	314	Peak
5725	54.84	52.6	68.3	-13.46	31.96	7.71	37.43	100	314	Peak

ANTENNA POLARITY & TEST DISTANCE: VERTICAL AT 3 M										
FREQ. (MHz)	EMISSION LEVEL (dBuV/m)	READ LEVEL (dBuV)	LIMIT (dBuV/m)	MARGIN (dB)	ANTENNA FACTOR (dB/m)	CABLE LOSS (dB)	PREAMP FACTOR (dB)	ANTENNA HEIGHT (cm)	TABLE ANGLE (Degree)	REMARK
5414	39.82	38.07	54	-14.18	31.53	7.4	37.18	100	339	Average
5414	55.76	54.01	74	-18.24	31.53	7.4	37.18	100	339	Peak
5470	54.43	52.41	68.3	-13.87	31.57	7.53	37.08	100	339	Peak
5580	93.06	90.94			31.71	7.57	37.16	100	339	Average
5580	102.9	100.78			31.71	7.57	37.16	100	339	Peak
5725	55.24	53	68.3	-13.06	31.96	7.71	37.43	100	339	Peak

REMARKS:

1. 5580MHz: Fundamental frequency.
2. 5470MHz & 5725MHz: Out of restricted band



EUT TEST CONDITION		MEASUREMENT DETAIL	
CHANNEL	Channel 140	FREQUENCY RANGE	1GHz ~ 40GHz
INPUT POWER (SYSTEM)	120Vac, 60 Hz	DETECTOR FUNCTION	Peak (PK) Average (AV)
ENVIRONMENTAL CONDITIONS	25deg. C, 65%RH	TESTED BY	Kay Wu

ANTENNA POLARITY & TEST DISTANCE: HORIZONTAL AT 3 M										
FREQ. (MHz)	EMISSION LEVEL (dBuV/m)	READ LEVEL (dBuV)	LIMIT (dBuV/m)	MARGIN (dB)	ANTENNA FACTOR (dB/m)	CABLE LOSS (dB)	PREAMP FACTOR (dB)	ANTENNA HEIGHT (cm)	TABLE ANGLE (Degree)	REMARK
5428	39.81	37.94	54	-14.19	31.53	7.47	37.13	100	194	Average
5428	55.64	53.77	74	-18.36	31.53	7.47	37.13	100	194	Peak
5470	53.54	51.52	68.3	-14.76	31.57	7.53	37.08	100	194	Peak
5700	83.29	81.1			31.9	7.69	37.4	100	194	Average
5700	93.08	90.89			31.9	7.69	37.4	100	194	Peak
5725	56.55	54.31	68.3	-11.75	31.96	7.71	37.43	100	194	Peak
ANTENNA POLARITY & TEST DISTANCE: VERTICAL AT 3 M										
FREQ. (MHz)	EMISSION LEVEL (dBuV/m)	READ LEVEL (dBuV)	LIMIT (dBuV/m)	MARGIN (dB)	ANTENNA FACTOR (dB/m)	CABLE LOSS (dB)	PREAMP FACTOR (dB)	ANTENNA HEIGHT (cm)	TABLE ANGLE (Degree)	REMARK
5416	39.93	38.18	54	-14.07	31.53	7.4	37.18	104	304	Average
5416	56.64	54.89	74	-17.36	31.53	7.4	37.18	104	304	Peak
5470	55.42	53.4	68.3	-12.88	31.57	7.53	37.08	104	304	Peak
5700	92.43	90.24			31.9	7.69	37.4	104	304	Average
5700	102.32	100.13			31.9	7.69	37.4	104	304	Peak
5725	67.36	65.12	68.3	-0.94	31.96	7.71	37.43	104	304	Peak

REMARKS:

- 5700MHz: Fundamental frequency.
- 5470MHz & 5725MHz: Out of restricted band



802.11n (40MHz)

EUT TEST CONDITION		MEASUREMENT DETAIL	
CHANNEL	Channel 38	FREQUENCY RANGE	1GHz ~ 40GHz
INPUT POWER (SYSTEM)	120Vac, 60 Hz	DETECTOR FUNCTION	Peak (PK) Average (AV)
ENVIRONMENTAL CONDITIONS	25deg. C, 65%RH	TESTED BY	Kay Wu

ANTENNA POLARITY & TEST DISTANCE: HORIZONTAL AT 3 M										
FREQ. (MHz)	EMISSION LEVEL (dBuV/m)	READ LEVEL (dBuV)	LIMIT (dBuV/m)	MARGIN (dB)	ANTENNA FACTOR (dB/m)	CABLE LOSS (dB)	PREAMP FACTOR (dB)	ANTENNA HEIGHT (cm)	TABLE ANGLE (Degree)	REMARK
5150	42.86	41.53	54	-11.14	31.32	7.33	37.32	100	49	Average
5150	58.41	57.08	74	-15.59	31.32	7.33	37.32	100	49	Peak
5190	82.31	80.98			31.35	7.32	37.34	100	49	Average
5190	91.6	90.27			31.35	7.32	37.34	100	49	Peak
5456	40.32	38.31	54	-13.68	31.56	7.53	37.08	100	49	Average
5456	57.05	55.04	74	-16.95	31.56	7.53	37.08	100	49	Peak
ANTENNA POLARITY & TEST DISTANCE: VERTICAL AT 3 M										
FREQ. (MHz)	EMISSION LEVEL (dBuV/m)	READ LEVEL (dBuV)	LIMIT (dBuV/m)	MARGIN (dB)	ANTENNA FACTOR (dB/m)	CABLE LOSS (dB)	PREAMP FACTOR (dB)	ANTENNA HEIGHT (cm)	TABLE ANGLE (Degree)	REMARK
5050	40.22	38.98	54	-13.78	31.24	7.25	37.25	100	30	Average
5050	55.86	54.62	74	-18.14	31.24	7.25	37.25	100	30	Peak
5190	75.59	74.26			31.35	7.32	37.34	100	30	Average
5190	84.95	83.62			31.35	7.32	37.34	100	30	Peak
5446	40.34	38.44	54	-13.66	31.56	7.47	37.13	100	30	Average
5446	55.97	54.07	74	-18.03	31.56	7.47	37.13	100	30	Peak

REMARKS: 5190MHz: Fundamental frequency.



EUT TEST CONDITION		MEASUREMENT DETAIL	
CHANNEL	Channel 46	FREQUENCY RANGE	1GHz ~ 40GHz
INPUT POWER (SYSTEM)	120Vac, 60 Hz	DETECTOR FUNCTION	Peak (PK) Average (AV)
ENVIRONMENTAL CONDITIONS	25deg. C, 65%RH	TESTED BY	Kay Wu

ANTENNA POLARITY & TEST DISTANCE: HORIZONTAL AT 3 M										
FREQ. (MHz)	EMISSION LEVEL (dBuV/m)	READ LEVEL (dBuV)	LIMIT (dBuV/m)	MARGIN (dB)	ANTENNA FACTOR (dB/m)	CABLE LOSS (dB)	PREAMP FACTOR (dB)	ANTENNA HEIGHT (cm)	TABLE ANGLE (Degree)	REMARK
5014	40.25	39.13	54	-13.75	31.21	7.14	37.23	103	23	Average
5014	55.62	54.5	74	-18.38	31.21	7.14	37.23	103	23	Peak
5230	84.53	83.12			31.39	7.34	37.32	103	23	Average
5230	93.64	92.23			31.39	7.34	37.32	103	23	Peak
5456	40.87	38.86	54	-13.13	31.56	7.53	37.08	103	23	Average
5456	56.43	54.42	74	-17.57	31.56	7.53	37.08	103	23	Peak
ANTENNA POLARITY & TEST DISTANCE: VERTICAL AT 3 M										
FREQ. (MHz)	EMISSION LEVEL (dBuV/m)	READ LEVEL (dBuV)	LIMIT (dBuV/m)	MARGIN (dB)	ANTENNA FACTOR (dB/m)	CABLE LOSS (dB)	PREAMP FACTOR (dB)	ANTENNA HEIGHT (cm)	TABLE ANGLE (Degree)	REMARK
5124	40.1	38.75	54	-13.9	31.31	7.34	37.3	100	257	Average
5124	55.32	53.97	74	-18.68	31.31	7.34	37.3	100	257	Peak
5230	77.4	75.99			31.39	7.34	37.32	100	257	Average
5230	86.72	85.31			31.39	7.34	37.32	100	257	Peak
5420	40.16	38.41	54	-13.84	31.53	7.4	37.18	100	257	Average
5420	56.57	54.82	74	-17.43	31.53	7.4	37.18	100	257	Peak

REMARKS: 5230MHz: Fundamental frequency.



A D T

EUT TEST CONDITION		MEASUREMENT DETAIL	
CHANNEL	Channel 54	FREQUENCY RANGE	1GHz ~ 40GHz
INPUT POWER (SYSTEM)	120Vac, 60 Hz	DETECTOR FUNCTION	Peak (PK) Average (AV)
ENVIRONMENTAL CONDITIONS	25deg. C, 65%RH	TESTED BY	Kay Wu

ANTENNA POLARITY & TEST DISTANCE: HORIZONTAL AT 3 M										
FREQ. (MHz)	EMISSION LEVEL (dBuV/m)	READ LEVEL (dBuV)	LIMIT (dBuV/m)	MARGIN (dB)	ANTENNA FACTOR (dB/m)	CABLE LOSS (dB)	PREAMP FACTOR (dB)	ANTENNA HEIGHT (cm)	TABLE ANGLE (Degree)	REMARK
5064	39.89	38.64	54	-14.11	31.25	7.25	37.25	103	354	Average
5064	56.29	55.04	74	-17.71	31.25	7.25	37.25	103	354	Peak
5270	84.81	83.31			31.41	7.36	37.27	103	354	Average
5270	94.79	93.29			31.41	7.36	37.27	103	354	Peak
5440	40.66	38.77	54	-13.34	31.55	7.47	37.13	103	354	Average
5440	56.26	54.37	74	-17.74	31.55	7.47	37.13	103	354	Peak
ANTENNA POLARITY & TEST DISTANCE: VERTICAL AT 3 M										
FREQ. (MHz)	EMISSION LEVEL (dBuV/m)	READ LEVEL (dBuV)	LIMIT (dBuV/m)	MARGIN (dB)	ANTENNA FACTOR (dB/m)	CABLE LOSS (dB)	PREAMP FACTOR (dB)	ANTENNA HEIGHT (cm)	TABLE ANGLE (Degree)	REMARK
5070	39.93	38.65	54	-14.07	31.25	7.3	37.27	100	256	Average
5070	55.99	54.71	74	-18.01	31.25	7.3	37.27	100	256	Peak
5270	77.62	76.12			31.41	7.36	37.27	100	256	Average
5270	86.97	85.47			31.41	7.36	37.27	100	256	Peak
5456	40.28	38.27	54	-13.72	31.56	7.53	37.08	100	256	Average
5456	56.3	54.29	74	-17.7	31.56	7.53	37.08	100	256	Peak

REMARKS: 5270MHz: Fundamental frequency.



EUT TEST CONDITION		MEASUREMENT DETAIL	
CHANNEL	Channel 62	FREQUENCY RANGE	1GHz ~ 40GHz
INPUT POWER (SYSTEM)	120Vac, 60 Hz	DETECTOR FUNCTION	Peak (PK) Average (AV)
ENVIRONMENTAL CONDITIONS	25deg. C, 65%RH	TESTED BY	Kay Wu

ANTENNA POLARITY & TEST DISTANCE: HORIZONTAL AT 3 M										
FREQ. (MHz)	EMISSION LEVEL (dBuV/m)	READ LEVEL (dBuV)	LIMIT (dBuV/m)	MARGIN (dB)	ANTENNA FACTOR (dB/m)	CABLE LOSS (dB)	PREAMP FACTOR (dB)	ANTENNA HEIGHT (cm)	TABLE ANGLE (Degree)	REMARK
5092	39.85	38.54	54	-14.15	31.28	7.3	37.27	100	353	Average
5092	55.27	53.96	74	-18.73	31.28	7.3	37.27	100	353	Peak
5310	85.13	83.47			31.45	7.4	37.19	100	353	Average
5310	94.29	92.63			31.45	7.4	37.19	100	353	Peak
5350	44.85	43.15	54	-9.15	31.48	7.4	37.18	100	353	Average
5350	60.99	59.29	74	-13.01	31.48	7.4	37.18	100	353	Peak
ANTENNA POLARITY & TEST DISTANCE: VERTICAL AT 3 M										
FREQ. (MHz)	EMISSION LEVEL (dBuV/m)	READ LEVEL (dBuV)	LIMIT (dBuV/m)	MARGIN (dB)	ANTENNA FACTOR (dB/m)	CABLE LOSS (dB)	PREAMP FACTOR (dB)	ANTENNA HEIGHT (cm)	TABLE ANGLE (Degree)	REMARK
5028	39.44	38.26	54	-14.56	31.23	7.19	37.24	100	257	Average
5028	55.87	54.69	74	-18.13	31.23	7.19	37.24	100	257	Peak
5310	76.89	75.23			31.45	7.4	37.19	100	257	Average
5310	86.12	84.46			31.45	7.4	37.19	100	257	Peak
5356	40.98	39.28	54	-13.02	31.48	7.4	37.18	100	257	Average
5356	55.74	54.04	74	-18.26	31.48	7.4	37.18	100	257	Peak

REMARKS: 5310MHz: Fundamental frequency.



A D T

EUT TEST CONDITION		MEASUREMENT DETAIL	
CHANNEL	Channel 102	FREQUENCY RANGE	1GHz ~ 40GHz
INPUT POWER (SYSTEM)	120Vac, 60 Hz	DETECTOR FUNCTION	Peak (PK) Average (AV)
ENVIRONMENTAL CONDITIONS	25deg. C, 65%RH	TESTED BY	Kay Wu

ANTENNA POLARITY & TEST DISTANCE: HORIZONTAL AT 3 M										
FREQ. (MHz)	EMISSION LEVEL (dBuV/m)	READ LEVEL (dBuV)	LIMIT (dBuV/m)	MARGIN (dB)	ANTENNA FACTOR (dB/m)	CABLE LOSS (dB)	PREAMP FACTOR (dB)	ANTENNA HEIGHT (cm)	TABLE ANGLE (Degree)	REMARK
5456	40.45	38.44	54	-13.55	31.56	7.53	37.08	112	321	Average
5456	55.97	53.96	74	-18.03	31.56	7.53	37.08	112	321	Peak
5470	56.3	54.28	68.3	-12	31.57	7.53	37.08	112	321	Peak
5510	80.78	78.65			31.6	7.59	37.06	112	321	Average
5510	90.31	88.18			31.6	7.59	37.06	112	321	Peak
5725	55.72	53.48	68.3	-12.58	31.96	7.71	37.43	112	321	Peak
ANTENNA POLARITY & TEST DISTANCE: VERTICAL AT 3 M										
FREQ. (MHz)	EMISSION LEVEL (dBuV/m)	READ LEVEL (dBuV)	LIMIT (dBuV/m)	MARGIN (dB)	ANTENNA FACTOR (dB/m)	CABLE LOSS (dB)	PREAMP FACTOR (dB)	ANTENNA HEIGHT (cm)	TABLE ANGLE (Degree)	REMARK
5424	41.72	39.97	54	-12.28	31.53	7.4	37.18	100	340	Average
5424	56.76	55.01	74	-17.24	31.53	7.4	37.18	100	340	Peak
5470	61.35	59.33	68.3	-6.95	31.57	7.53	37.08	100	340	Peak
5510	88.56	86.43			31.6	7.59	37.06	100	340	Average
5510	98.05	95.92			31.6	7.59	37.06	100	340	Peak
5725	54.94	52.7	68.3	-13.36	31.96	7.71	37.43	100	340	Peak

REMARKS:

1. 5510MHz: Fundamental frequency.
2. 5470MHz & 5725MHz: Out of restricted band



EUT TEST CONDITION		MEASUREMENT DETAIL	
CHANNEL	Channel 110	FREQUENCY RANGE	1GHz ~ 40GHz
INPUT POWER (SYSTEM)	120Vac, 60 Hz	DETECTOR FUNCTION	Peak (PK) Average (AV)
ENVIRONMENTAL CONDITIONS	25deg. C, 65%RH	TESTED BY	Kay Wu

ANTENNA POLARITY & TEST DISTANCE: HORIZONTAL AT 3 M										
FREQ. (MHz)	EMISSION LEVEL (dBuV/m)	READ LEVEL (dBuV)	LIMIT (dBuV/m)	MARGIN (dB)	ANTENNA FACTOR (dB/m)	CABLE LOSS (dB)	PREAMP FACTOR (dB)	ANTENNA HEIGHT (cm)	TABLE ANGLE (Degree)	REMARK
5446	40.59	38.69	54	-13.41	31.56	7.47	37.13	113	320	Average
5446	55.98	54.08	74	-18.02	31.56	7.47	37.13	113	320	Peak
5470	55.36	53.34	68.3	-12.94	31.57	7.53	37.08	113	320	Peak
5550	82.06	79.89			31.68	7.58	37.09	113	320	Average
5550	91.63	89.46			31.68	7.58	37.09	113	320	Peak
5725	55.47	53.23	68.3	-12.83	31.96	7.71	37.43	113	320	Peak
ANTENNA POLARITY & TEST DISTANCE: VERTICAL AT 3 M										
FREQ. (MHz)	EMISSION LEVEL (dBuV/m)	READ LEVEL (dBuV)	LIMIT (dBuV/m)	MARGIN (dB)	ANTENNA FACTOR (dB/m)	CABLE LOSS (dB)	PREAMP FACTOR (dB)	ANTENNA HEIGHT (cm)	TABLE ANGLE (Degree)	REMARK
5410	42.01	40.27	54	-11.99	31.52	7.4	37.18	100	338	Average
5410	55.49	53.75	74	-18.51	31.52	7.4	37.18	100	338	Peak
5470	54.89	52.87	68.3	-13.41	31.57	7.53	37.08	100	338	Peak
5550	89.82	87.65			31.68	7.58	37.09	100	338	Average
5550	99.92	97.75			31.68	7.58	37.09	100	338	Peak
5725	55.5	53.26	68.3	-12.8	31.96	7.71	37.43	100	338	Peak

REMARKS:

- 5550MHz: Fundamental frequency.
- 5470MHz & 5725MHz: Out of restricted band



EUT TEST CONDITION		MEASUREMENT DETAIL	
CHANNEL	Channel 134	FREQUENCY RANGE	1GHz ~ 40GHz
INPUT POWER (SYSTEM)	120Vac, 60 Hz	DETECTOR FUNCTION	Peak (PK) Average (AV)
ENVIRONMENTAL CONDITIONS	25deg. C, 65%RH	TESTED BY	Kay Wu

ANTENNA POLARITY & TEST DISTANCE: HORIZONTAL AT 3 M										
FREQ. (MHz)	EMISSION LEVEL (dBuV/m)	READ LEVEL (dBuV)	LIMIT (dBuV/m)	MARGIN (dB)	ANTENNA FACTOR (dB/m)	CABLE LOSS (dB)	PREAMP FACTOR (dB)	ANTENNA HEIGHT (cm)	TABLE ANGLE (Degree)	REMARK
5412	40.17	38.42	54	-13.83	31.53	7.4	37.18	100	319	Average
5412	55.75	54	74	-18.25	31.53	7.4	37.18	100	319	Peak
5470	53.61	51.59	68.3	-14.69	31.57	7.53	37.08	100	319	Peak
5670	80.57	78.37			31.88	7.66	37.34	100	319	Average
5670	90.07	87.87			31.88	7.66	37.34	100	319	Peak
5725	54.41	52.17	68.3	-13.89	31.96	7.71	37.43	100	319	Peak
ANTENNA POLARITY & TEST DISTANCE: VERTICAL AT 3 M										
FREQ. (MHz)	EMISSION LEVEL (dBuV/m)	READ LEVEL (dBuV)	LIMIT (dBuV/m)	MARGIN (dB)	ANTENNA FACTOR (dB/m)	CABLE LOSS (dB)	PREAMP FACTOR (dB)	ANTENNA HEIGHT (cm)	TABLE ANGLE (Degree)	REMARK
5458	40.26	38.25	54	-13.74	31.56	7.53	37.08	108	337	Average
5458	56.56	54.55	74	-17.44	31.56	7.53	37.08	108	337	Peak
5470	55.31	53.29	68.3	-12.99	31.57	7.53	37.08	108	337	Peak
5670	90.48	88.28			31.88	7.66	37.34	108	337	Average
5670	99.88	97.68			31.88	7.66	37.34	108	337	Peak
5725	56.73	54.49	68.3	-11.57	31.96	7.71	37.43	108	337	Peak

REMARKS:

- 5670MHz: Fundamental frequency.
- 5470MHz & 5725MHz: Out of restricted band



BELOW 1GHz WORST-CASE DATA : 802.11a

EUT TEST CONDITION		MEASUREMENT DETAIL	
CHANNEL	Channel 140	FREQUENCY RANGE	30MHz ~ 1GHz
INPUT POWER (SYSTEM)	120Vac, 60 Hz	DETECTOR FUNCTION	Peak (PK) Average (AV)
ENVIRONMENTAL CONDITIONS	25deg. C, 65%RH	TESTED BY	Kay Wu

ANTENNA POLARITY & TEST DISTANCE: HORIZONTAL AT 3 M										
FREQ. (MHz)	EMISSION LEVEL (dBuV/m)	READ LEVEL (dBuV)	LIMIT (dBuV/m)	MARGIN (dB)	ANTENNA FACTOR (dB/m)	CABLE LOSS (dB)	PREAMP FACTOR (dB)	ANTENNA HEIGHT (cm)	TABLE ANGLE (Degree)	REMARK
43.23	18.35	35.16	40	-21.65	13.59	0.71	31.11	141	357	Peak
148.26	16.09	33.74	43.5	-27.41	12.64	1.33	31.62	102	351	Peak
240.06	16.96	35.89	46	-29.04	11.07	1.79	31.79	100	275	Peak
374.2	21.27	36.15	46	-24.73	14.73	2.32	31.93	102	243	Peak
594.7	23.82	33.46	46	-22.18	19.48	3.07	32.19	112	36	Peak
786.5	27.01	32.72	46	-18.99	22.04	3.66	31.41	117	284	Peak
ANTENNA POLARITY & test distance: VERTICAL at 3 m										
FREQ. (MHz)	EMISSION LEVEL (dBuV/m)	READ LEVEL (dBuV)	LIMIT (dBuV/m)	MARGIN (dB)	ANTENNA FACTOR (dB/m)	CABLE LOSS (dB)	PREAMP FACTOR (dB)	ANTENNA HEIGHT (cm)	TABLE ANGLE (Degree)	REMARK
57.54	20.14	38.43	40	-19.86	12.25	0.81	31.35	103	246	Peak
153.66	15.51	33.12	43.5	-27.99	12.72	1.36	31.69	112	192	Peak
255.99	15.63	34.02	46	-30.37	11.65	1.85	31.89	104	331	Peak
405	22	36.15	46	-24	15.45	2.45	32.05	113	276	Peak
598.2	23.62	33.2	46	-22.38	19.57	3.08	32.23	103	190	Peak
757.8	26.71	32.9	46	-19.29	21.63	3.59	31.41	100	50	Peak



4.2 CONDUCTED EMISSION MEASUREMENT

4.2.1 LIMITS OF CONDUCTED EMISSION MEASUREMENT

FREQUENCY OF EMISSION (MHz)	CONDUCTED LIMIT (dB μ V)	
	Quasi-peak	Average
0.15 ~ 0.5	66 to 56	56 to 46
0.5 ~ 5	56	46
5 ~ 30	60	50

- NOTE:** 1. The lower limit shall apply at the transition frequencies.
2. The limit decreases in line with the logarithm of the frequency in the range of 0.15 to 0.50MHz.
3. All emanations from a class A/B digital device or system, including any network of conductors and apparatus connected thereto, shall not exceed the level of field strengths specified above.

4.2.2 TEST INSTRUMENTS

DESCRIPTION & MANUFACTURER	MODEL NO.	SERIAL NO.	DATE OF CALIBRATION	DUE DATE OF CALIBRATION
Test Receiver ROHDE & SCHWARZ	ESCS30	100288	Nov. 09, 2012	Nov. 08, 2013
RF signal cable Woken	5D-FB	Cable-HYCO2-01	Dec. 28, 2012	Dec. 27, 2013
LISN ROHDE & SCHWARZ (EUT)	ESH2-Z5	100100	Dec. 21, 2012	Dec. 20, 2013
LISN ROHDE & SCHWARZ (Peripheral)	ESH3-Z5	100311	Jul. 06, 2012	Jul. 05, 2013
Software ADT	BV ADT_Cond_ V7.3.7.3	NA	NA	NA

- NOTE:** 1. The calibration interval of the above test instruments is 12 months and the calibrations are traceable to NML/ROC and NIST/USA.
2. The test was performed in HwaYa Shielded Room 2.
3. The VCCI Site Registration No. is C-2047.

4.2.3 TEST PROCEDURES

- The EUT was placed 0.4 meters from the conducting wall of the shielded room with EUT being connected to the power mains through a line impedance stabilization network (LISN). Other support units were connected to the power mains through another LISN. The two LISNs provide 50 ohm/ 50uH of coupling impedance for the measuring instrument.
- Both lines of the power mains connected to the EUT were checked for maximum conducted interference.
- The frequency range from 150kHz to 30MHz was searched. Emission levels under (Limit - 20dB) was not recorded.

NOTE: All modes of operation were investigated and the worst-case emissions are reported.

4.2.4 DEVIATION FROM TEST STANDARD

No deviation.

4.2.5 TEST SETUP

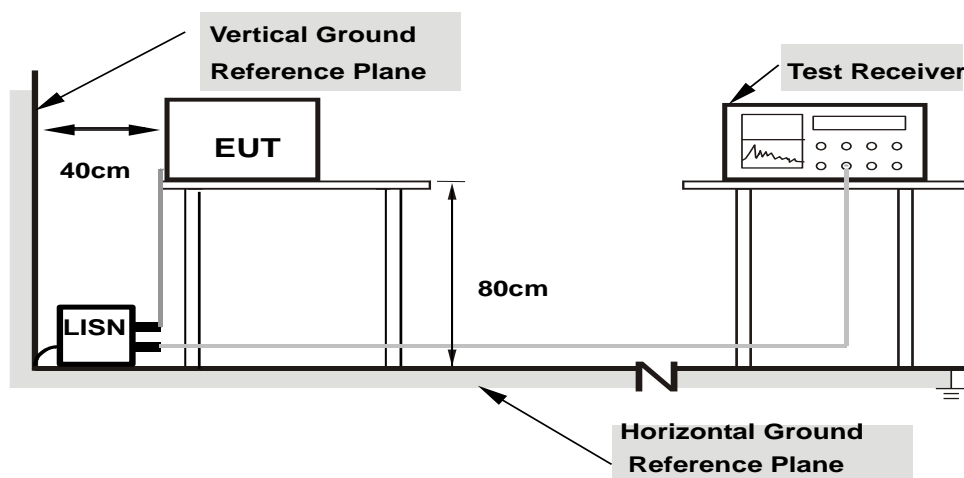

- Note:**
- Support units were connected to second LISN.
 - Both of LISNs (AMN) are 80 cm from EUT and at least 80 from other units and other metal planes

For the actual test configuration, please refer to the attached file (Test Setup Photo).

4.2.6 EUT OPERATING CONDITIONS

Same as 4.1.6.

4.2.7 TEST RESULTS

CONDUCTED WORST-CASE DATA : 802.11a

PHASE	Line 1	6dB BANDWIDTH	9kHz
--------------	--------	----------------------	------

No	Freq. [MHz]	Corr. Factor (dB)	Reading Value [dB (uV)]		Emission Level [dB (uV)]		Limit [dB (uV)]		Margin (dB)	
			Q.P.	AV.	Q.P.	AV.	Q.P.	AV.	Q.P.	AV.
1	0.15391	0.12	40.76	27.70	40.88	27.82	65.79	55.79	-24.90	-27.96
2	0.40781	0.15	45.03	39.31	45.18	39.46	57.69	47.69	-12.51	-8.23
3	0.47422	0.16	45.44	38.11	45.60	38.27	56.44	46.44	-10.84	-8.17
4	0.88828	0.20	40.80	33.55	41.00	33.75	56.00	46.00	-15.00	-12.25
5	1.21875	0.21	40.83	31.93	41.04	32.14	56.00	46.00	-14.96	-13.86
6	13.56250	0.86	55.45	53.25	56.31	54.11	60.00	50.00	-3.69	4.11

REMARKS:

1. Q.P. and AV. are abbreviations of quasi-peak and average individually.
2. The emission levels of other frequencies were very low against the limit.
3. Margin value = Emission level - Limit value
4. Correction factor = Insertion loss + Cable loss
5. Emission Level = Correction Factor + Reading Value.
6. No. 6 is NFC signal inductive with measurement system. Please check P50-51 to see test result for EUT with a suitable dummy load.

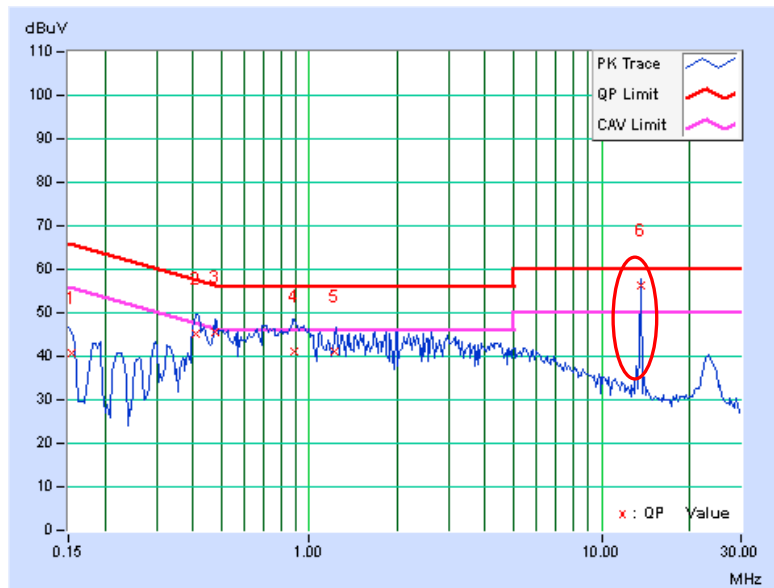

PHASE	Line 2	6dB BANDWIDTH	9kHz
-------	--------	---------------	------

No	Freq. [MHz]	Corr. Factor (dB)	Reading Value [dB (uV)]		Emission Level [dB (uV)]		Limit [dB (uV)]		Margin (dB)	
			Q.P.	AV.	Q.P.	AV.	Q.P.	AV.	Q.P.	AV.
			1	0.15391	0.17	43.34	33.58	43.51	33.75	65.79
2	0.41172	0.21	40.01	32.74	40.22	32.95	57.61	47.61	-17.39	-14.66
3	0.98984	0.25	35.67	27.60	35.92	27.85	56.00	46.00	-20.08	-18.15
4	1.58984	0.27	36.28	27.62	36.55	27.89	56.00	46.00	-19.45	-18.11
5	13.55859	0.71	54.37	51.87	55.08	52.58	60.00	50.00	-4.92	2.58
6	23.19922	1.00	32.54	21.39	33.54	22.39	60.00	50.00	-26.46	-27.61

REMARKS:

1. Q.P. and AV. are abbreviations of quasi-peak and average individually.
2. The emission levels of other frequencies were very low against the limit.
3. Margin value = Emission level - Limit value
4. Correction factor = Insertion loss + Cable loss
5. Emission Level = Correction Factor + Reading Value.
6. No. 5 is NFC signal inductive with measurement system. Please check P50-51 to see test result for EUT with a suitable dummy load.

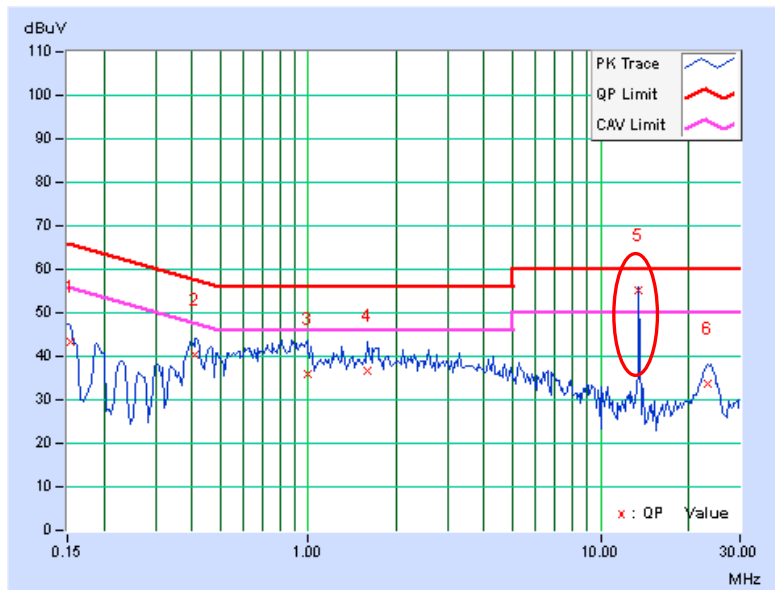

Test with suitable dummy load

PHASE	Line 1	6dB BANDWIDTH	9kHz
-------	--------	---------------	------

No	Freq. [MHz]	Corr. Factor (dB)	Reading Value		Emission Level		Limit		Margin	
			[dB (uV)]		[dB (uV)]		[dB (uV)]		(dB)	
			Q.P.	AV.	Q.P.	AV.	Q.P.	AV.	Q.P.	AV.
1	0.15391	0.12	46.65	37.79	46.77	37.91	65.79	55.79	-19.01	-17.87
2	0.46250	0.16	40.04	30.90	40.20	31.06	56.65	46.65	-16.45	-15.59
3	0.88438	0.20	39.68	29.79	39.88	29.99	56.00	46.00	-16.12	-16.01
4	2.49219	0.26	38.58	29.89	38.84	30.15	56.00	46.00	-17.16	-15.85
5	6.79688	0.49	34.03	24.03	34.52	24.52	60.00	50.00	-25.48	-25.48
6	18.04688	1.12	26.76	16.61	27.88	17.73	60.00	50.00	-32.12	-32.27

REMARKS:

1. Q.P. and AV. are abbreviations of quasi-peak and average individually.
2. The emission levels of other frequencies were very low against the limit.
3. Margin value = Emission level - Limit value
4. Correction factor = Insertion loss + Cable loss
5. Emission Level = Correction Factor + Reading Value.

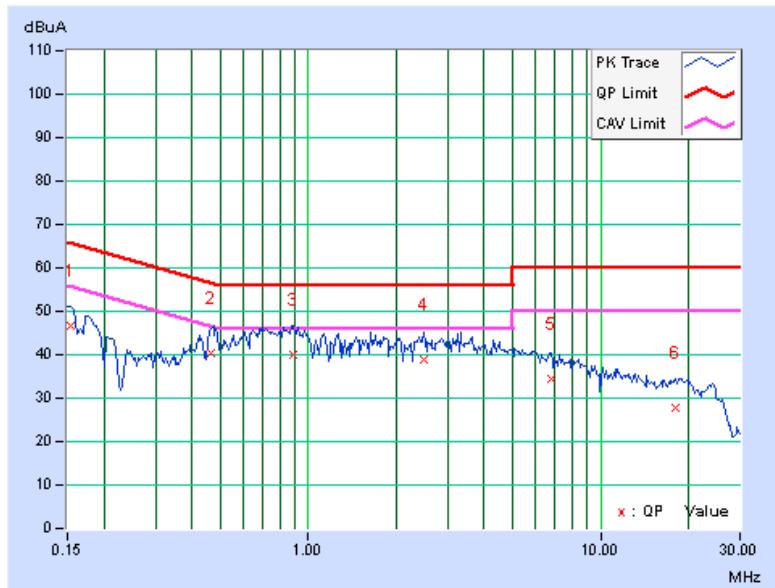

PHASE	Line 2	6dB BANDWIDTH	9kHz
-------	--------	---------------	------

No	Freq. [MHz]	Corr. Factor (dB)	Reading Value		Emission Level		Limit		Margin	
			[dB (uV)]		[dB (uV)]		[dB (uV)]		(dB)	
			Q.P.	AV.	Q.P.	AV.	Q.P.	AV.	Q.P.	AV.
1	0.15000	0.18	44.74	35.49	44.92	35.67	66.00	56.00	-21.08	-20.33
2	0.47031	0.21	43.04	36.26	43.25	36.47	56.51	46.51	-13.25	-10.03
3	0.96641	0.25	38.28	29.76	38.53	30.01	56.00	46.00	-17.47	-15.99
4	1.44531	0.26	36.91	28.23	37.17	28.49	56.00	46.00	-18.83	-17.51
5	9.46484	0.57	25.38	17.58	25.95	18.15	60.00	50.00	-34.05	-31.85
6	24.05859	1.02	29.80	18.52	30.82	19.54	60.00	50.00	-29.18	-30.46

REMARKS:

1. Q.P. and AV. are abbreviations of quasi-peak and average individually.
2. The emission levels of other frequencies were very low against the limit.
3. Margin value = Emission level - Limit value
4. Correction factor = Insertion loss + Cable loss
5. Emission Level = Correction Factor + Reading Value.

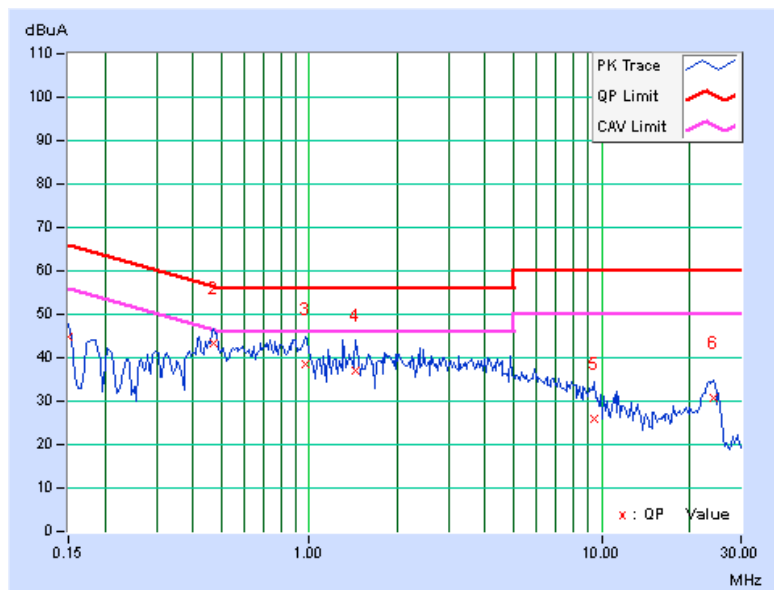

4.3 PEAK TRANSMIT POWER MEASUREMENT

4.3.1 LIMITS OF PEAK TRANSMIT POWER MEASUREMENT

FREQUENCY BAND	LIMIT
5.150 ~ 5.250GHz	The lesser of 50mW (17dBm) or 4dBm + 10logB
5.250 ~ 5.350GHz	The lesser of 250mW (24dBm) or 11dBm + 10logB
5.470 ~ 5.725GHz	The lesser of 250mW (24dBm) or 11dBm + 10logB

NOTE: Where B is the 26dB emission bandwidth in MHz.

4.3.2 TEST SETUP

FOR POWER OUTPUT MEASUREMENT

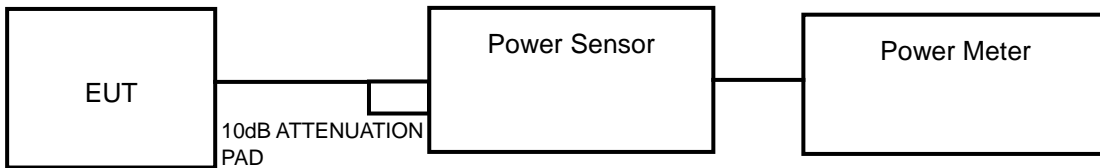

or

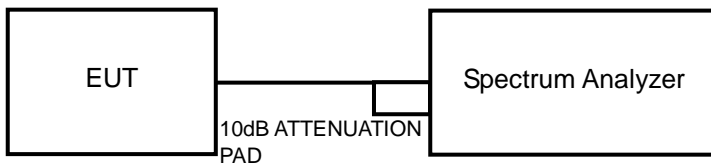

FOR 26dB BANDWIDTH

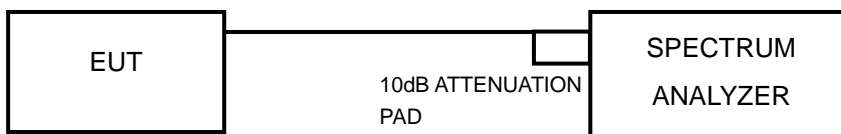

4.3.3 TEST INSTRUMENTS

Refer to section 4.1.3 to get information of above instrument.

4.3.4 TEST PROCEDURE

FOR AVERAGE POWER MEASUREMENT

<802.11a, 802.11n (20MHz), 802.11n (40MHz)>

Method PM is used to perform output power measurement, trigger and gating function of wide band power meter is enabled to measure max output power of TX on burst. Duty factor is not added to measured value.

<802.11 ac (80MHz)>

Method SA-1 is used to perform output power measurement, trigger and gating function of spectrum analyzer is enabled to measure max output power of TX on burst. Duty factor is not added to measured value.

FOR 26dB BANDWIDTH

- 1) Set RBW = approximately 1% of the emission bandwidth.
- 2) Set the VBW > RBW.
- 3) Detector = Peak.
- 4) Trace mode = max hold.
- 5) Measure the maximum width of the emission that is 26 dB down from the peak of the emission. Compare this with the RBW setting of the analyzer. Readjust RBW and repeat measurement as needed until the RBW/EBW ratio is approximately 1%.

4.3.5 DEVIATION FROM TEST STANDARD

No deviation.

4.3.6 EUT OPERATING CONDITIONS

The software provided by client to enable the EUT under transmission condition continuously at specific channel frequencies individually.



4.3.7 TEST RESULTS

POWER OUTPUT: 802.11a

CHANNEL	CHANNEL FREQUENCY (MHz)	AVERAGE POWER (mW)	AVERAGE POWER (dBm)	POWER LIMIT (dBm)	PASS/FAIL
36	5180	15.346	11.86	17	PASS
44	5220	15.704	11.96	17	PASS
48	5240	15.596	11.93	17	PASS
52	5260	15.959	12.03	24	PASS
60	5300	15.885	12.01	24	PASS
64	5320	15.704	11.96	24	PASS
100	5500	16.032	12.05	24	PASS
116	5580	15.453	11.89	24	PASS
140	5700	16.255	12.11	24	PASS

802.11n (20MHz)

CHANNEL	CHANNEL FREQUENCY (MHz)	AVERAGE POWER (mW)	AVERAGE POWER (dBm)	POWER LIMIT (dBm)	PASS/FAIL
36	5180	13.900	11.43	17	PASS
44	5220	12.853	11.09	17	PASS
48	5240	12.853	11.09	17	PASS
52	5260	14.322	11.56	24	PASS
60	5300	13.397	11.27	24	PASS
64	5320	13.183	11.20	24	PASS
100	5500	13.677	11.36	24	PASS
116	5580	14.158	11.51	24	PASS
140	5700	14.060	11.48	24	PASS

802.11n (40MHz)

CHANNEL	CHANNEL FREQUENCY (MHz)	AVERAGE POWER (mW)	AVERAGE POWER (dBm)	POWER LIMIT (dBm)	PASS/FAIL
38	5190	11.830	10.73	17	PASS
46	5230	13.709	11.37	17	PASS
54	5270	13.677	11.36	24	PASS
62	5310	14.289	11.55	24	PASS
102	5510	12.359	10.92	24	PASS
110	5550	11.858	10.74	24	PASS
134	5670	13.366	11.26	24	PASS

**26dB BANDWIDTH:****802.11a**

CHANNEL	CHANNEL FREQUENCY (MHz)	26dBc BANDWIDTH (MHz)	PASS / FAIL
36	5180	22.27	PASS
44	5220	22.92	PASS
48	5240	22.03	PASS
52	5260	21.87	PASS
60	5300	22.36	PASS
64	5320	21.70	PASS
100	5500	22.37	PASS
116	5580	22.04	PASS
140	5700	22.05	PASS

802.11n (20MHz)

CHANNEL	CHANNEL FREQUENCY (MHz)	26dBc BANDWIDTH (MHz)	PASS / FAIL
36	5180	22.99	PASS
44	5220	23.63	PASS
48	5240	22.97	PASS
52	5260	23.13	PASS
60	5300	22.61	PASS
64	5320	25.15	PASS
100	5500	24.64	PASS
116	5580	23.11	PASS
140	5700	23.10	PASS

802.11n (40MHz)

CHANNEL	CHANNEL FREQUENCY (MHz)	26dBc BANDWIDTH (MHz)	PASS / FAIL
38	5190	46.22	PASS
46	5230	46.29	PASS
54	5270	46.38	PASS
62	5310	47.96	PASS
102	5510	51.49	PASS
110	5550	45.67	PASS
134	5670	45.47	PASS

4.4 PEAK POWER SPECTRAL DENSITY MEASUREMENT

4.4.1 LIMITS OF PEAK POWER SPECTRAL DENSITY MEASUREMENT

FREQUENCY BAND	LIMIT
5.150 ~ 5.250GHz	4dBm
5.250 ~ 5.350GHz	11dBm
5.470 ~ 5.725GHz	11dBm

4.4.2 TEST SETUP

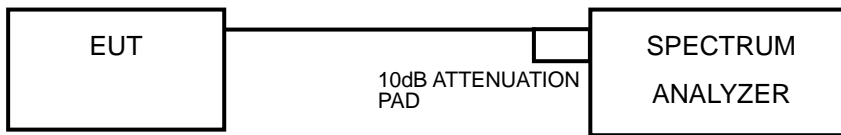

4.4.3 TEST INSTRUMENTS

Refer to section 4.1.3 to get information of above instrument.

4.4.4 TEST PROCEDURES

<802.11a, 802.11n (20MHz), 802.11n (40MHz)>

Using method SA-2 alternative

- 1) Set span to encompass the entire emission bandwidth (EBW) of the signal.
- 2) Set RBW = 1 MHz, Set VBW \geq 3 MHz, Detector = RMS
- 3) Sweep time = 4second.
- 4) Perform a single sweep.
- 5) Record the max value and add 10 log (1/duty cycle)

<802.11ac (80MHz)>

Using method SA-1

- 1) Set span to encompass the entire emission bandwidth (EBW) of the signal.
- 2) Set RBW = 1 MHz, Set VBW \geq 3 MHz, Detector = RMS
- 3) Sweep time = 4second.
- 4) Perform a single sweep.



4.4.5 DEVIATION FROM TEST STANDARD

No deviation.

4.4.6 EUT OPERATING CONDITIONS

Same as 4.3.6.

4.4.7 TEST RESULTS

802.11a

CHANNEL	FREQUENCY (MHz)	PSD W/O DUTY FACTOR (dBm)	DUTY FACTOR	PSD WITH DUTY FACTOR (dBm)	MAXIMUM LIMIT (dBm)	PASS/FAIL
36	5180	-6.36	5.06	-1.30	4	PASS
44	5220	-5.79	5.06	-0.73	4	PASS
48	5240	-5.60	5.06	-0.54	4	PASS
52	5260	-5.35	5.06	-0.29	11	PASS
60	5300	-4.74	5.06	0.32	11	PASS
64	5320	-4.81	5.06	0.25	11	PASS
100	5500	-5.16	5.06	-0.10	11	PASS
116	5580	-5.71	5.06	-0.65	11	PASS
140	5700	-9.00	5.06	-3.94	11	PASS

NOTE: Refer to section 3.3 for duty cycle spectrum plot.



802.11n (20MHz)

CHANNEL	FREQUENCY (MHz)	PSD W/O DUTY FACTOR (dBm)	DUTY FACTOR	PSD WITH DUTY FACTOR (dBm)	MAXIMUM LIMIT (dBm)	PASS/FAIL
36	5180	-3.32	1.04	-2.28	4	PASS
44	5220	-3.29	1.04	-2.25	4	PASS
48	5240	-2.58	1.04	-1.54	4	PASS
52	5260	-2.44	1.04	-1.40	11	PASS
60	5300	-1.97	1.04	-0.93	11	PASS
64	5320	-2.09	1.04	-1.05	11	PASS
100	5500	-2.27	1.04	-1.23	11	PASS
116	5580	-3.02	1.04	-1.98	11	PASS
140	5700	-4.33	1.04	-3.29	11	PASS

NOTE: Refer to section 3.3 for duty cycle spectrum plot.

802.11n (40MHz)

CHANNEL	FREQUENCY (MHz)	PSD W/O DUTY FACTOR (dBm)	DUTY FACTOR	PSD WITH DUTY FACTOR (dBm)	MAXIMUM LIMIT (dBm)	PASS/FAIL
38	5190	-7.62	1.05	-6.57	4	PASS
46	5230	-7.51	1.05	-6.46	4	PASS
54	5270	-6.80	1.05	-5.75	11	PASS
62	5310	-6.78	1.05	-5.73	11	PASS
102	5510	-7.69	1.05	-6.64	11	PASS
110	5550	-6.48	1.05	-5.43	11	PASS
134	5670	-7.99	1.05	-6.94	11	PASS

NOTE: Refer to section 3.3 for duty cycle spectrum plot.

4.5 PEAK POWER EXCURSION MEASUREMENT

4.5.1 LIMITS OF PEAK POWER EXCURSION MEASUREMENT

Shall not exceed 13 dB.

4.5.2 TEST SETUP

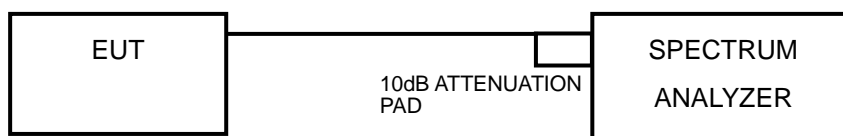

4.5.3 TEST INSTRUMENTS

Refer to section 4.1.3 to get information of above instrument.

4.5.4 TEST PROCEDURE

- 1) Set RBW = 1 MHz, VBW \geq 3 MHz, Detector = peak.
- 2) Trace mode = max-hold. Allow the sweeps to continue until the trace stabilizes.
- 3) Use the peak search function to find the peak of the spectrum.
- 4) Measure the PPSD.
- 5) Compute the ratio of the maximum of the peak-max-hold spectrum to the PPSD.

4.5.5 DEVIATION FROM TEST STANDARD

No deviation.

4.5.6 EUT OPERATING CONDITIONS

Same as 4.2.6

4.5.7 TEST RESULTS

802.11a

CHAN.	CHANNEL FREQUENCY (MHz)	PEAK VALUE (dBm)	PPSD WITHOUT DUTY FACTOR (dBm)	PPSD WITH DUTY FACTOR (dBm)	PEAK POWER EXCURSION (dB)	PEAK to AVERAGE EXCURSION LIMIT (dB)	PASS /FAIL
36	5180	9.46	-6.36	-1.30	10.76	13	PASS
44	5220	10.50	-5.79	-0.73	11.23	13	PASS
48	5240	9.74	-5.60	-0.54	10.28	13	PASS
52	5260	10.52	-5.35	-0.29	10.81	13	PASS
60	5300	10.39	-4.74	0.32	10.07	13	PASS
64	5320	10.53	-4.81	0.25	10.28	13	PASS
100	5500	10.30	-5.16	-0.10	10.40	13	PASS
116	5580	11.47	-5.71	-0.65	12.12	13	PASS
140	5700	5.22	-9.00	-3.94	9.16	13	PASS

NOTE: Refer to section 3.3 for duty cycle spectrum plot.

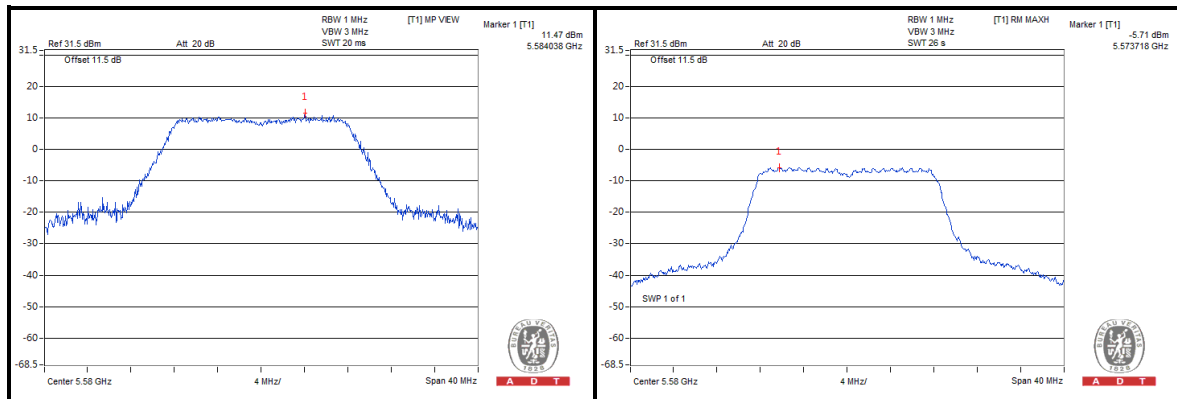

802.11n (20MHz)

CHAN.	CHANNEL FREQUENCY (MHz)	PEAK VALUE (dBm)	PPSD WITHOUT DUTY FACTOR (dBm)	PPSD WITH DUTY FACTOR (dBm)	PEAK POWER EXCURSION (dB)	PEAK to AVERAGE EXCURSION LIMIT (dB)	PASS /FAIL
36	5180	9.03	-3.32	-2.28	11.31	13	PASS
44	5220	7.76	-3.29	-2.25	10.01	13	PASS
48	5240	8.31	-2.58	-1.54	9.85	13	PASS
52	5260	9.08	-2.44	-1.40	10.48	13	PASS
60	5300	8.72	-1.97	-0.93	9.65	13	PASS
64	5320	10.96	-2.09	-1.05	12.01	13	PASS
100	5500	9.71	-2.27	-1.23	10.94	13	PASS
116	5580	8.37	-3.02	-1.98	10.35	13	PASS
140	5700	8.96	-4.33	-3.29	12.25	13	PASS

NOTE: Refer to section 3.3 for duty cycle spectrum plot.

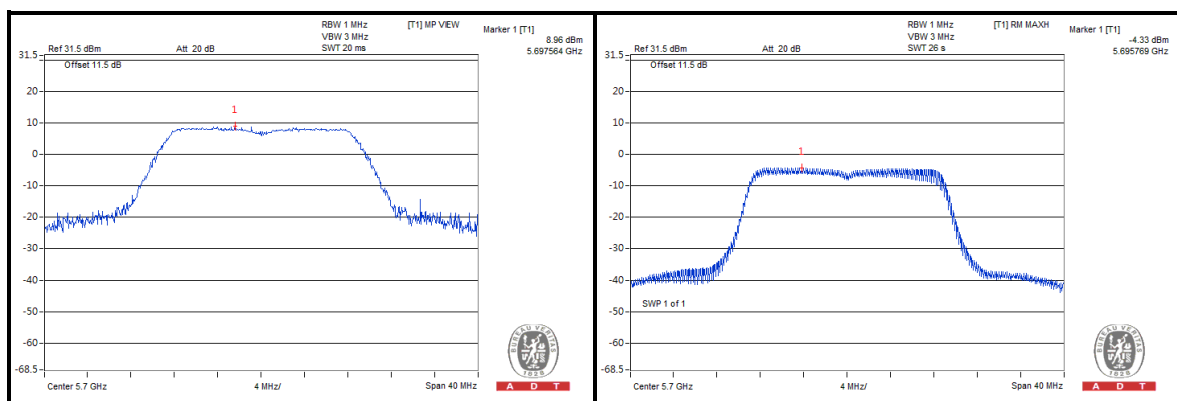

802.11n (40MHz)

CHAN.	CHANNEL FREQUENCY (MHz)	PEAK VALUE (dBm)	PPSD WITHOUT DUTY FACTOR (dBm)	PPSD WITH DUTY FACTOR (dBm)	PEAK POWER EXCURSION (dB)	PEAK to AVERAGE EXCURSION LIMIT (dB)	PASS /FAIL
38	5190	4.85	-7.62	-6.57	11.42	13	PASS
46	5230	5.58	-7.51	-6.46	12.04	13	PASS
54	5270	6.30	-6.80	-5.75	12.05	13	PASS
62	5310	6.32	-6.78	-5.73	12.05	13	PASS
102	5510	5.39	-7.69	-6.64	12.03	13	PASS
110	5550	5.41	-6.48	-5.43	10.84	13	PASS
134	5670	5.71	-7.99	-6.94	12.65	13	PASS

NOTE: Refer to section 3.3 for duty cycle spectrum plot.

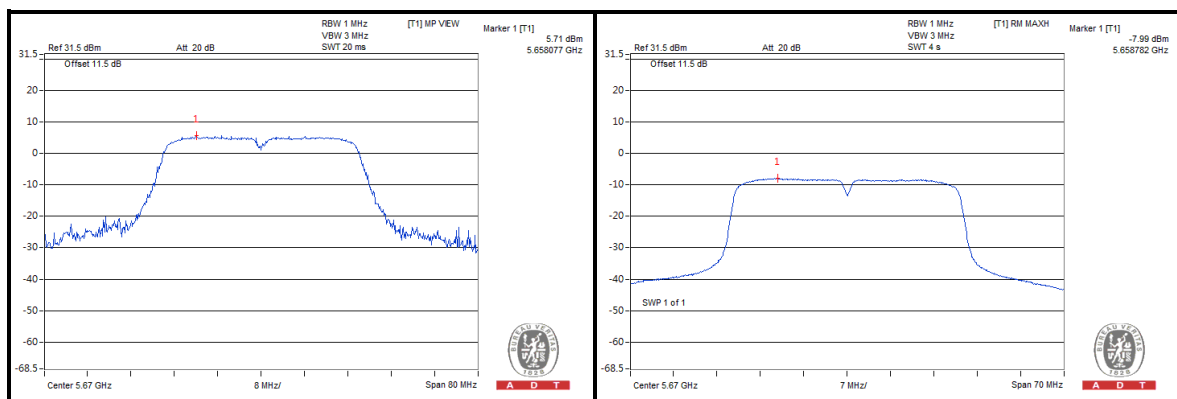

4.6 FREQUENCY STABILITY

4.6.1 LIMITS OF FREQUENCY STABILITY MEASUREMENT

The frequency of the carrier signal shall be maintained within band of operation

4.6.2 TEST SETUP

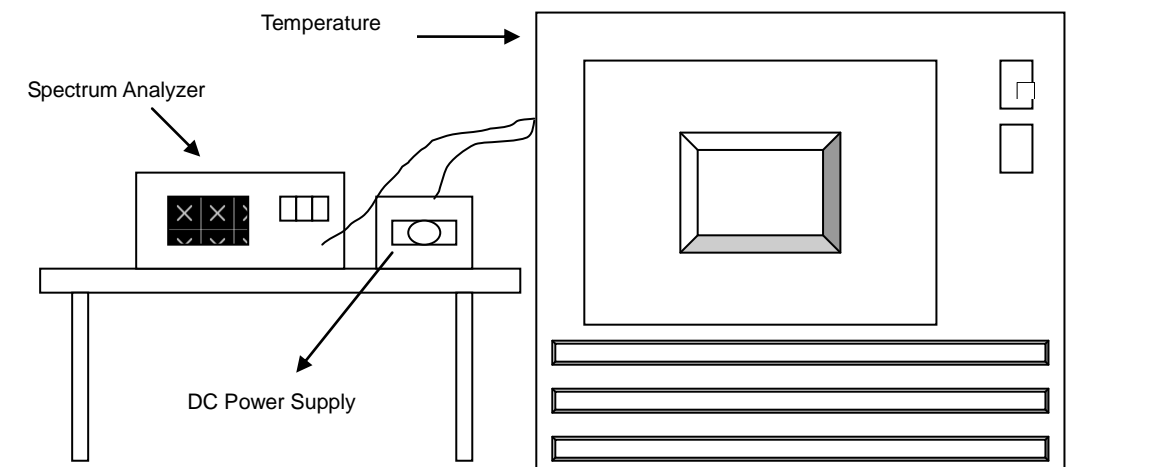

4.6.3 TEST INSTRUMENTS

Refer to section 4.1.3 to get information of above instrument.

4.6.4 TEST PROCEDURE

- a. To ensure emission at the band edge is maintained within the authorized band, those values shall be measured by radiation emissions at upper and lower frequency points, and finally compensated by frequency deviation as procedures below.
- b. The EUT was operated at the maximum output power, and connected to the spectrum analyzer, which is set to maximum hold function and peak detector. The peak value of the power envelope was measured and noted. The upper and lower frequency points were respectively measured relatively 10dB lower than the measured peak value.
- c. The frequency deviation was calculated by adding the upper frequency point and the lower frequency point divided by two. Those detailed values of frequency deviation are provided in table below.

4.6.5 DEVIATION FROM TEST STANDARD

No deviation.

4.6.6 EUT OPERATING CONDITION

Set the EUT transmit at un-modulation mode to test frequency stability.



4.6.7 TEST RESULTS

FREQUENCY STABILITY VERSUS TEMP.									
OPERATING FREQUENCY: 5320MHz									
TEMP. (°C)	POWER SUPPLY (Vdc)	0 MINUTE		2 MINUTE		5 MINUTE		10 MINUTE	
		Measured Frequency (MHz)	Frequency Drift (ppm)	Measured Frequency (MHz)	Frequency Drift (ppm)	Measured Frequency (MHz)	Frequency Drift (ppm)	Measured Frequency (MHz)	Frequency Drift (ppm)
50	3.8	5320.015122	2.842	5320.015242	2.865	5320.014849	2.791	5320.014924	2.805
40	3.8	5320.015773	2.965	5320.015413	2.897	5320.015280	2.872	5320.015875	2.984
30	3.8	5320.016994	3.194	5320.016858	3.169	5320.017027	3.201	5320.016728	3.144
20	3.8	5320.017948	3.374	5320.017999	3.383	5320.018255	3.431	5320.017966	3.377
10	3.8	5320.019440	3.654	5320.019585	3.681	5320.019498	3.665	5320.019599	3.684
0	3.8	5320.017966	3.377	5320.017674	3.322	5320.018339	3.447	5320.017710	3.329
-10	3.8	5320.016426	3.088	5320.016769	3.152	5320.016735	3.146	5320.017013	3.198
-20	3.8	5320.015926	2.994	5320.015701	2.951	5320.015733	2.957	5320.016073	3.021
-30	3.8	5320.014835	2.789	5320.014935	2.807	5320.015103	2.839	5320.014932	2.807

FREQUENCY STABILITY VERSUS VOLTAGE									
OPERATING FREQUENCY: 5320MHz									
TEMP. (°C)	POWER SUPPLY (Vac)	0 MINUTE		2 MINUTE		5 MINUTE		10 MINUTE	
		Measured Frequency (MHz)	Frequency Drift (ppm)	Measured Frequency (MHz)	Frequency Drift (ppm)	Measured Frequency (MHz)	Frequency Drift (ppm)	Measured Frequency (MHz)	Frequency Drift (ppm)
20	3.4	5320.017570	3.303	5320.017273	3.247	5320.017510	3.291	5320.017310	3.254
	3.8	5320.017948	3.374	5320.017999	3.383	5320.018255	3.431	5320.017966	3.377
	4.35	5320.019210	3.611	5320.019205	3.610	5320.019408	3.648	5320.019331	3.634



A D T

5. PHOTOGRAPHS OF THE TEST CONFIGURATION

Please refer to the attached file (Test Setup Photo).



6. INFORMATION ON THE TESTING LABORATORIES

We, Bureau Veritas Consumer Products Services (H.K.) Ltd., Taoyuan Branch, were founded in 1988 to provide our best service in EMC, Radio, Telecom and Safety consultation. Our laboratories are accredited and approved according to ISO/IEC 17025.

If you have any comments, please feel free to contact us at the following:

Linko EMC/RF Lab:

Tel: 886-2-26052180

Fax: 886-2-26051924

Hsin Chu EMC/RF Lab:

Tel: 886-3-5935343

Fax: 886-3-5935342

Hwa Ya EMC/RF/Safety Telecom Lab:

Tel: 886-3-3183232

Fax: 886-3-3270892

Email: service.adt@tw.bureauveritas.com

Web Site: www.bureauveritas-adt.com

The address and road map of all our labs can be found in our web site also.



A D T

7. APPENDIX A - MODIFICATIONS RECORDERS FOR ENGINEERING CHANGES TO THE EUT BY THE LAB

No modifications were made to the EUT by the lab during the test.

---END---