



RADIATED SPURIOUS EMISSIONS PORTIONS OF
FCC CFR47 PART 24 SUBPART E
CERTIFICATION TEST REPORT
FOR
SINGLE BAND CDMA MOBILE PHONE WITH BLUETOOTH + WiFi
FCC MODEL NUMBER: C5170
FCC ID: V65C5170
REPORT NUMBER: 12U114325-1
ISSUE DATE: MARCH 28, 2012

Prepared for

KYOCERA COMMUNICATIONS, INC
9520 TOWNE CENTRE DRIVE
SAN DIEGO, CA 92121, U.S.A.

Prepared by

COMPLIANCE CERTIFICATION SERVICES (UL CCS)
47173 BENICIA STREET
FREMONT, CA 94538, U.S.A.
TEL: (510) 771-1000
FAX: (510) 661-0888



NVLAP LAB CODE 200065-0

Revision History

<u>Rev.</u>	<u>Issue Date</u>	<u>Revisions</u>	<u>Revised By</u>
---	03/28/12	Initial Issue	T. Chan

TABLE OF CONTENTS

1. ATTESTATION OF TEST RESULTS.....	4
2. TEST METHODOLOGY	5
3. FACILITIES AND ACCREDITATION.....	5
4. CALIBRATION AND UNCERTAINTY	5
4.1. MEASURING INSTRUMENT CALIBRATION.....	5
4.2. SAMPLE CALCULATION.....	5
4.3. MEASUREMENT UNCERTAINTY.....	5
5. EQUIPMENT UNDER TEST	6
5.1. DESCRIPTION OF EUT.....	6
5.2. MAXIMUM OUTPUT POWER.....	6
5.3. SOFTWARE AND FIRMWARE.....	6
5.4. WORST-CASE CONFIGURATION AND MODE	6
5.5. DESCRIPTION OF TEST SETUP.....	8
6. TEST AND MEASUREMENT EQUIPMENT	10
7. LIMITS AND RESULTS	11
7.1. RADIATED OUTPUT POWER.....	11
7.2. FIELD STRENGTH OF SPURIOUS RADIATION	13
8. SETUP PHOTOS.....	16

1. ATTESTATION OF TEST RESULTS

COMPANY NAME: KYOCERA COMMUNICATIONS, INC
9520 TOWNE CENTRE DRIVE
SAN DIEGO, CA 92121, U.S.A

EUT DESCRIPTION: TRI BAND CDMA MOBILE PHONE WITH BLUETOOTH + WiFi

MODEL: C5170

SERIAL NUMBER: 268435457816725953

DATE TESTED: MARCH 19, 2012

APPLICABLE STANDARDS	
STANDARD	TEST RESULTS
FCC PART 24E	PASS (Radiated Portion)

Compliance Certification Services, Inc. (UL CCS) tested the above equipment in accordance with the requirements set forth in the above standards. All indications of Pass/Fail in this report are opinions expressed by UL CCS based on interpretations and/or observations of test results. Measurement Uncertainties were not taken into account and are published for informational purposes only. The test results show that the equipment tested is capable of demonstrating compliance with the requirements as documented in this report.

Note: The results documented in this report apply only to the tested sample, under the conditions and modes of operation as described herein. This document may not be altered or revised in any way unless done so by UL CCS and all revisions are duly noted in the revisions section. Any alteration of this document not carried out by UL CCS will constitute fraud and shall nullify the document. This report must not be used by the client to claim product certification, approval, or endorsement by NVLAP, NIST, any agency of the Federal Government, or any agency of any government.

Approved & Released For UL CCS By:



THU CHAN
ENGINEERING MANAGER
UL CCS

Tested By:

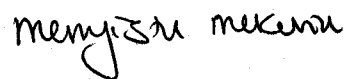

MENGISTU MEKURIA
EMC ENGINEER
UL CCS

2. TEST METHODOLOGY

The tests documented in this report were performed in accordance with TIA-603-C, FCC CFR 47 Part 2, FCC CFR Part 24, FCC Part 27.

3. FACILITIES AND ACCREDITATION

The test sites and measurement facilities used to collect data are located at 47173 Benicia Street, Fremont, California, USA.

UL CCS is accredited by NVLAP, Laboratory Code 200065-0. The full scope of accreditation can be viewed at <http://www.ccsemc.com>.

4. CALIBRATION AND UNCERTAINTY

4.1. MEASURING INSTRUMENT CALIBRATION

The measuring equipment utilized to perform the tests documented in this report has been calibrated in accordance with the manufacturer's recommendations, and is traceable to recognized national standards.

4.2. SAMPLE CALCULATION

Where relevant, the following sample calculation is provided:

$$\text{Field Strength (dBuV/m)} = \text{Measured Voltage (dBuV)} + \text{Antenna Factor (dB/m)} + \text{Cable Loss (dB)} - \text{Preamp Gain (dB)}$$

$$36.5 \text{ dBuV} + 18.7 \text{ dB/m} + 0.6 \text{ dB} - 26.9 \text{ dB} = 28.9 \text{ dBuV/m}$$

4.3. MEASUREMENT UNCERTAINTY

Where relevant, the following measurement uncertainty levels have been estimated for tests performed on the apparatus:

PARAMETER	UNCERTAINTY
Conducted Disturbance, 0.15 to 30 MHz	3.52 dB
Radiated Disturbance, 30 to 1000 MHz	4.94 dB

Uncertainty figures are valid to a confidence level of 95%.

5. EQUIPMENT UNDER TEST

5.1. DESCRIPTION OF EUT

The EUT is Bluetooth featured Tri Band CDMA Phone that is manufactured by Kyocera Communications, Inc.

5.2. MAXIMUM OUTPUT POWER

The transmitter has a maximum peak ERP & EIRP output powers as follows:

Part 24 PCS Band

Frequency range (MHz)	Modulation	EIRP	
		dBm	mW
1851.25 – 1908.75	1xRTT	27.91	618.0

5.3. SOFTWARE AND FIRMWARE

The EUT is linked with Agilent, Rohde & Schwarz, or Anritsu Communication Test Set.

5.4. WORST-CASE CONFIGURATION AND MODE

The worst-position was the EUT with highest emissions. To determine the worst-case, the EUT was investigated for X, Y, and Z-Positions, and the worst position among X, Y, or Z with AC/DC adapter and headset, after the investigations, the worst-position was turned out to be X-Position without AC Adapter and with headset.

PROCEDURE USED TO ESTABLISH TEST SIGNAL

3G-CDMA2000 1xRTT

This procedure assumes the Agilent E5515C Test Set has the following applications installed and with valid license.

<u>Application</u>	<u>Rev. License</u>
CDMA2000 Mobil Test	B.10.11, L

1xRTT

- Call Setup > Shift & Preset
- Protocol Rev > 6 (IS-2000-0)
- Radio Config (RC) > RC3 (Fwd3, Rvs3)
- FCH Service Option (SO) Setup > 55
- Traffic Data Rate > Full
- TDSO SCH Info > F-SCH Parameters > F-SCH Data Rate > 153.6 kbps
> R-SCH Parameters > R-SCH Data Rate > 153.6 kbps
- Cell Info > Cell Parameters > System ID (SID) > 4395
> Network ID (NID) > 0
> Initial Registration Channel > 1125 (PCS)

Once "Active Cell" show "Connected " then change "Rvs Power Ctrl" from "Active bits" to "**All Up bits**" to get the maximum power.

Worst-case Measurement Result @ Low, Middle and High Channel

Worst-case Measurement Result for Low, Middle and High Channel under Radio Configuration RC3 and Service Option 55.

5.5. DESCRIPTION OF TEST SETUP

SUPPORT EQUIPMENT

PERIPHERAL SUPPORT EQUIPMENT LIST				
Description	Manufacturer	Model	Serial Number	FCC ID
AC Adapter	Kyocera	CSP-31ADT	SSW-2001	DoC
Earphone	--	--	--	--

I/O CABLES

I/O CABLE LIST						
Cable No.	Port	# of Identical Ports	Connector Type	Cable Type	Cable Length	Remarks
2	DC	1	USB	Shielded	1m	Mic on Cable
3	Mic	1	Earphone	Un-shielded	1m	NA

TEST SETUP

The EUT is a CDMA phone and is tested as a standalone configuration. Communications Test Set is used to link the device under test.

SETUP DIAGRAM FOR TESTS

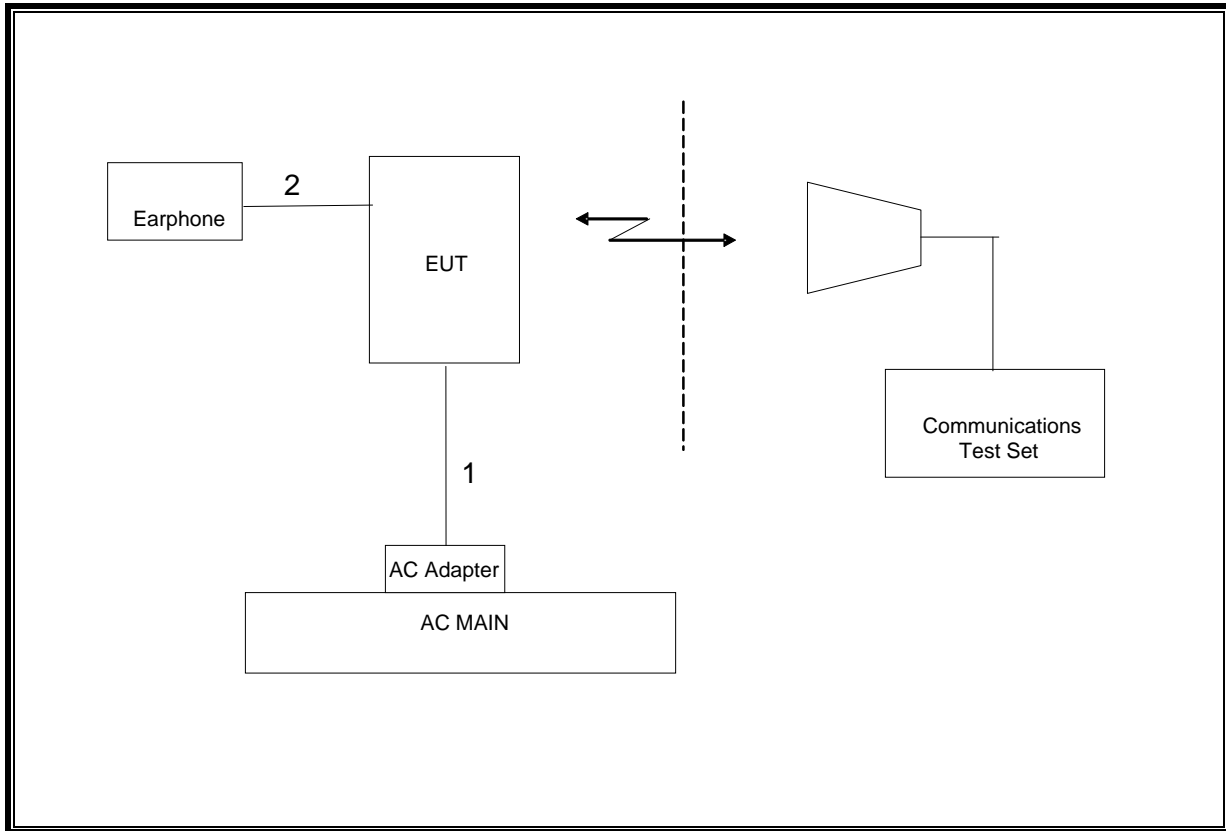

6. TEST AND MEASUREMENT EQUIPMENT

The following test and measurement equipment was utilized for the tests documented in this report:

TEST EQUIPMENT LIST				
Description	Manufacturer	Model	Asset	Cal Due
Spectrum Analyzer, 44 GHz	Agilent / HP	E4446A	C01069	12/15/12
Communications Test Set	Agilent / HP	E5515C	1000732	09/27/12
Signal Generator, 20 GHz	Agilent / HP	83732B	C00774	07/14/12
EMI Test Receiver, 30 MHz	R & S	ESHS 20	N02396	08/19/13
Antenna, Horn, 18 GHz	EMCO	3115	C00783	06/29/12
Antenna, Horn, 18 GHz	EMCO	3115	C00872	06/29/12
Antenna, Bilog, 2 GHz	Sunol Sciences	JB1	C01011	07/16/12
Preamplifier, 1300 MHz	Agilent / HP	8447D	C00885	01/27/12
Preamplifier, 26.5 GHz	Agilent / HP	8449B	C01052	07/12/12
Preamplifier, 26.5 GHz	Agilent / HP	8449B	C01063	07/12/12
LISN, 30 MHz	FCC	50/250-25-2	C00626	12/13/12
Dipole	EMCO	3121C-DB4	00-22117	07/16/12
Highpass Filter, 2.7 GHz	Micro-Tronics	HPM13194	N02687	CNR

7. LIMITS AND RESULTS

7.1. RADIATED OUTPUT POWER

LIMITS

24.232(b) & RSS133 § 6.4 Mobile/portable stations are limited to 2 watts e.i.r.p. peak power and the equipment must employ means to limit the power to the minimum necessary for successful communications.

TEST PROCEDURE

ANSI / TIA / EIA 603 Clause 2.2.17 & FCC 24.238 (b), (g) (1)(2)(3).

RESULTS

PCS OUTPUT POWER (EIRP)

High Frequency Fundamental Measurement Compliance Certification Services Chamber B								
Company:		KYOCERA						
Project #:		12U14325						
Date:		03/19/12						
Test Engineer:		MENGISTU MEKURIA						
Configuration:		EUT ALONE						
Mode:		TX, PCS BAND CDMA 2000, 1xRTT						
Test Equipment:								
Receiving: Horn T59, and Camber B SMA Cables								
Substitution: Horn T60 Substitution, 6ft SMA Cable (208947003) Warehouse								
f GHz	SG reading (dBm)	Ant. Pol. (H/V)	Cable Loss (dB)	Antenna Gain (dBi)	EIRP (dBm)	Limit (dBm)	Delta (dB)	Notes
1.851	13.1	V	0.85	8.00	20.26	33.0	-12.7	
1.851	20.5	H	0.85	8.00	27.61	33.0	-5.4	
1.880	11.7	V	0.85	8.10	18.95	33.0	-14.1	
1.880	20.1	H	0.85	8.10	27.38	33.0	-5.6	
1.909	11.5	V	0.85	8.14	18.82	33.0	-14.2	
1.909	20.6	H	0.85	8.14	27.91	33.0	-5.1	
Rev. 3.17.11								

7.2. FIELD STRENGTH OF SPURIOUS RADIATION

LIMIT

§24.238 (a), RSS-133 § 6.5.1 (a) (i) & (b): Out of band emissions The power of any emission outside of the authorized operating frequency ranges must be attenuated below the transmitting power (P) by a factor of at least $43 + 10 \log (P)$ dB.

TEST PROCEDURE

ANSI / TIA / EIA 603 Clause 3.2.12 & FCC 24.238 (b), (g) (1)(2)(3).

RESULTS

PCS Spurious & Harmonic (EIRP)

Compliance Certification Services Above 1GHz High Frequency Substitution Measurement									
Company:		KYOCERA							
Project #:		12U14325							
Date:		03/19/12							
Test Engineer:		MENGISTU MEKURIA							
Configuration:		EUT ALONE							
Mode:		TX, PCS BAND CDMA 2000, 1xRTT							
Chamber		Pre-amplifer			Filter		Limit		
5m Chamber B		T145 8449B			Filter 1		Part 24		
f GHz	SG reading (dBm)	Ant. Pol. (H/V)	Distance (m)	Preamp (dB)	Filter (dB)	EIRP (dBm)	Limit (dBm)	Delta (dB)	Notes
Low Ch, 1851.25MHz									
3.703	-20.2	V	3.0	35.4	1.0	-54.5	-13.0	-41.5	
5.554	-16.4	V	3.0	35.4	1.0	-50.8	-13.0	-37.8	
3.703	-21.0	H	3.0	35.4	1.0	-55.3	-13.0	-42.3	
5.554	-18.0	H	3.0	35.4	1.0	-52.4	-13.0	-39.4	
Mid Ch, 1880.00MHz									
3.760	-17.7	V	3.0	35.3	1.0	-52.0	-13.0	-39.0	
5.640	-15.5	V	3.0	35.4	1.0	-50.0	-13.0	-37.0	
3.760	-18.0	H	3.0	35.3	1.0	-52.3	-13.0	-39.3	
5.640	-16.1	H	3.0	35.4	1.0	-50.5	-13.0	-37.5	
High Ch, 1908.75MHz									
3.818	-18.8	V	3.0	35.3	1.0	-53.1	-13.0	-40.1	
5.726	-11.5	V	3.0	35.4	1.0	-46.0	-13.0	-33.0	
3.818	-19.7	H	3.0	35.3	1.0	-54.0	-13.0	-41.0	
5.726	-13.2	H	3.0	35.4	1.0	-47.7	-13.0	-34.7	
Rev. 03.03.09									
Note: No other emissions were detected above the system noise floor.									

SPURIOUS EMISSIONS BELOW 1000 MHz (WORST-CASE CONFIGURATION)

Note: No emissions above the noise floor were observed.