

FCC RF Test Report

APPLICANT : PAX Technology Limited
EQUIPMENT : Mobile payment Terminal
BRAND NAME : PAX
MODEL NAME : S90
FCC ID : V5PS90CDMA
STANDARD : FCC 47 CFR Part 2, 22(H), 24(E)
CLASSIFICATION : PCS Licensed Transmitter (PCB)
Tx/Rx FREQUENCY RANGE : CDMA2000 BC0 : 824.70 ~ 848.31 MHz /
869.70 ~ 893.31 MHz
CDMA2000 BC1 : 1851.25 ~ 1908.75 MHz /
1931.25 ~ 1988.75 MHz
MAX. ERP/EIRP POWER : CDMA2000 BC0 : 0.14 W
CDMA2000 BC1 : 0.23 W
EMISSION DESIGNATOR : 1M28F9W

The product was received on Sep. 08, 2011 and completely tested on Oct. 07, 2011. We, SPORTON INTERNATIONAL (KUNSHAN) INC., would like to declare that the tested sample has been evaluated in accordance with the procedures given in ANSI / TIA / EIA-603-C-2004 and shown compliance with the applicable technical standards.

The test results in this report apply exclusively to the tested model / sample. Without written approval of SPORTON INTERNATIONAL (KUNSHAN) INC., the test report shall not be reproduced except in full.

Reviewed by:



Jones Tsai / Manager



SPORTON INTERNATIONAL (KUNSHAN) INC.
No. 3-2, PingXiang Road, Kunshan, Jiangsu Province, P.R.C.



TABLE OF CONTENTS

REVISION HISTORY..... 3

SUMMARY OF TEST RESULT 4

1 GENERAL DESCRIPTION 5

 1.1 Applicant..... 5

 1.2 Manufacturer 5

 1.3 Feature of Equipment Under Test..... 5

 1.4 Testing Site 6

 1.5 Applied Standards 6

 1.6 Ancillary Equipment List..... 6

2 TEST CONFIGURATION OF EQUIPMENT UNDER TEST 7

 2.1 Test Mode..... 7

 2.2 Connection Diagram of Test System 8

3 TEST RESULT..... 9

 3.1 Conducted Output Power Measurement..... 9

 3.2 Effective Radiated Power and Effective Isotropic Radiated Power Measurement 11

 3.3 Occupied Bandwidth Measurement 14

 3.4 Band Edge Measurement..... 17

 3.5 Conducted Emission Measurement 20

 3.6 Field Strength of Spurious Radiation Measurement 26

 3.7 Frequency Stability Measurement..... 32

4 LIST OF MEASURING EQUIPMENTS 36

5 UNCERTAINTY OF EVALUATION..... 37

APPENDIX A. PHOTOGRAPHS OF EUT

APPENDIX B. SETUP PHOTOGRAPHS



REVISION HISTORY

REPORT NO.	VERSION	DESCRIPTION	ISSUED DATE
FG190809	Rev. 01	Initial issue of report	Oct. 14, 2011



SUMMARY OF TEST RESULT

Report Section	FCC Rule	Description	Limit	Result	Remark
3.1	§2.1046	Conducted Output Power	N/A	PASS	-
3.2	§22.913(a)(2)	Effective Radiated Power	< 7 Watts	PASS	-
3.2	§24.232(c)	Equivalent Isotropic Radiated Power	< 2 Watts	PASS	-
3.3	§2.1049 §22.917(a) §24.238(a)	Occupied Bandwidth	N/A	PASS	-
3.4	§2.1051 §22.917(a) §24.238(a)	Band Edge Measurement	< 43+10log ₁₀ (P[Watts])	PASS	-
3.5	§2.1051 §22.917(a) §24.238(a)	Conducted Emission	< 43+10log ₁₀ (P[Watts])	PASS	-
3.6	§2.1053 §22.917(a) §24.238(a)	Field Strength of Spurious Radiation	< 43+10log ₁₀ (P[Watts])	PASS	Under limit 25.04 dB at 2509 MHz
3.7	§2.1055 §22.355 §24.235	Frequency Stability for Temperature & Voltage	< 2.5 ppm	PASS	-

1 General Description

1.1 Applicant

PAX Technology Limited

Room 2416, 24/F., Sun Hung Kai Centre, 30 Harbour Road, Wanchai, Hong Kong

1.2 Manufacturer

PAX Computer Technology (Shenzhen) Co., Ltd.

4/F No.3 Building, Software Park, Second Central Science-Tech Road, High-Tech industrial Park, Shenzhen, Guangdong, P.R.C.

1.3 Feature of Equipment Under Test

Product Feature & Specification	
Equipment	Mobile payment Terminal
Brand Name	PAX
Model Name	S90
FCC ID	V5PS90CDMA
Tx Frequency	CDMA2000 BC0 : 824 MHz ~ 849 MHz CDMA2000 BC1 : 1850 MHz ~ 1910 MHz
Rx Frequency	CDMA2000 BC0 : 869 MHz ~ 894 MHz CDMA2000 BC1 : 1930 MHz ~ 1990 MHz
Maximum Output Power to Antenna	CDMA2000 BC0 : 23.72 dBm CDMA2000 BC1 : 23.79 dBm
Maximum ERP/EIRP	CDMA2000 BC0 : 0.14 W (21.50 dBm) CDMA2000 BC1 : 0.23 W (23.64 dBm)
Antenna Type	Fixed Internal Antenna
HW Version	S90-XXX-XX2-XXXX
SW Version	V1.XX
Type of Modulation	QPSK
Type of Emission	1M28F9W
EUT Stage	Production Unit

Remark:

1. This test report recorded only product characteristics and test results of PCS Licensed Transmitter (PCB).
2. The above EUT's information was declared by manufacturer. Please refer to the specifications or user's manual for more detailed description.

1.4 Testing Site

Test Site	SPORTON INTERNATIONAL (KUNSHAN) INC.	
Test Site Location	No. 3-2, PingXiang Road, Kunshan, Jiangsu Province, P.R.C. TEL: +86-0512-5790-0158 FAX: +86-0512-5790-0958	
Test Site No.	Sporton Site No.	
	TH01-KS	03CH01-KS

1.5 Applied Standards

According to the specifications of the manufacturer, the EUT must comply with the requirements of the following standards:

- Preliminary Guidance for Receiving Applications for Certification of 3G Device. May 9, 2006.
- 47 CFR Part 2, 22(H), 24(E)
- ANSI / TIA / EIA-603-C-2004

Remark:

1. All test items were verified and recorded according to the standards and without any deviation during the test.
2. This EUT has also been tested and complied with the requirements of FCC Part 15, Subpart B (DoC), recorded in a separate test report.

1.6 Ancillary Equipment List

Item	Equipment	Trade Name	Model No.	FCC ID	Data Cable	Power Cord
1.	System Simulator	R&S	CMU200	N/A	N/A	Unshielded, 1.8 m
2.	DC Power Supply	GW	GPS-30300	N/A	N/A	Unshielded, 1.8 m

2 Test Configuration of Equipment Under Test

2.1 Test Mode

During all testing, EUT is in link mode with base station emulator at maximum power level. The spurious emission measurements were carried out in semi-anechoic chamber with 3-meter test range, and EUT is rotated on three test planes to find out the worst emission.

Frequency range investigated for radiated emission is as follows:

1. 30 MHz to 9000 MHz for CDMA2000 BC0.
2. 30 MHz to 19000 MHz for CDMA2000 BC1.

Test Modes		
Band	Radiated TCs	Conducted TCs
CDMA2000 BC0	■ 1xRTT Link Mode	■ 1xRTT Link Mode
CDMA2000 BC1	■ 1xRTT Link Mode	■ 1xRTT Link Mode

Note:

The maximum RF output power levels are 1xRTT RC3+SO32 mode for CDMA2000 BC0, and 1xRTT RC3+SO32 mode for CDMA2000 BC1 on QPSK link; only these modes were used for all tests.

The conducted power tables are as follows:

Conducted Power (*Unit: dBm)						
Band	CDMA2000 BC0			CDMA2000 BC1		
Channel	1013	384	777	25	600	1175
Frequency	824.7	836.52	848.31	1851.25	1880	1908.75
1xRTT RC1+SO55	23.59	23.69	23.56	23.68	23.61	23.27
1xRTT RC3+SO55	23.64	23.71	23.56	23.76	23.60	23.33
1xRTT RC3+SO32(+F-SCH)	23.67	23.72	23.58	23.79	23.64	23.37
1xRTT RC3+SO32(+SCH)	23.64	23.69	23.58	23.77	23.62	23.31

2.2 Connection Diagram of Test System

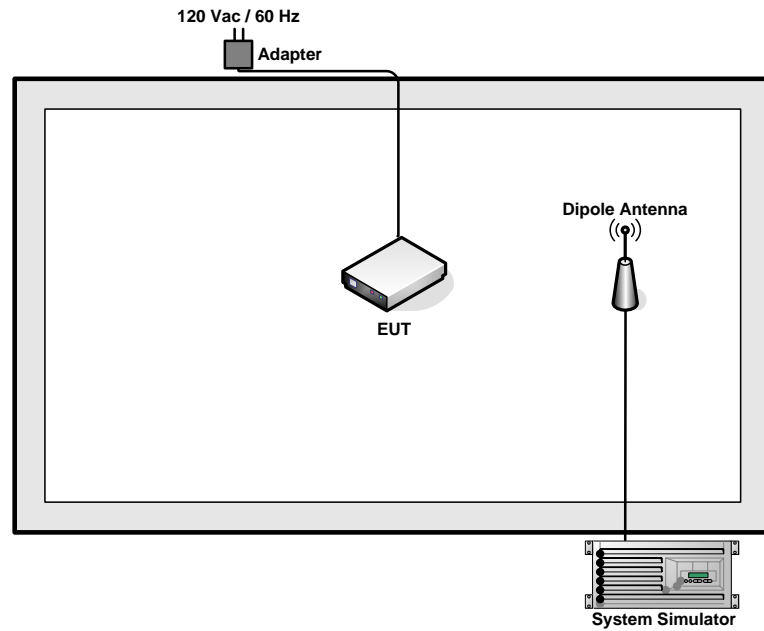

3 Test Result

3.1 Conducted Output Power Measurement

3.1.1 Description of the Conducted Output Power Measurement

A base station simulator was used to establish communication with the EUT. Its parameters were set to transmit the maximum power on the EUT. The measured power in the radio frequency on the transmitter output terminals shall be reported.

3.1.2 Measuring Instruments

See list of measuring instruments of this test report.

3.1.3 Test Procedures

1. The transmitter output port was connected to base station.
2. Set EUT at maximum power through base station.
3. Select lowest, middle, and highest channels for each band and different modulation.

3.1.4 Test Setup

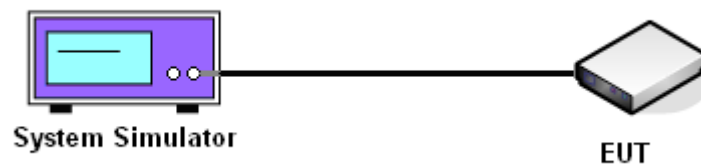

3.1.5 Test Result of Conducted Output Power

CDMA2000 BC0					
Test Mode	Test Status	Channel	Frequency (MHz)	Conducted Power (dBm)	Conducted Power (Watts)
CDMA 2000 1xRTT	RC3+SO32	1013 (Low)	824.70	23.67	0.23
		384 (Mid)	836.52	23.72	0.24
		777 (High)	848.31	23.58	0.23

CDMA2000 BC1					
Test Mode	Test Status	Channel	Frequency (MHz)	Conducted Power (dBm)	Conducted Power (Watts)
CDMA 2000 1xRTT	RC3+SO32	25 (Low)	1851.25	23.79	0.24
		600 (Mid)	1880.00	23.64	0.23
		1175 (High)	1908.75	23.37	0.22

3.2 Effective Radiated Power and Effective Isotropic Radiated Power Measurement

3.2.1 Description of the ERP/EIRP Measurement

ERP/EIRP is measured by substitution method according to ANSI / TIA / EIA-603-C-2004. The ERP of mobile transmitters must not exceed 7 Watts for 824 MHz ~ 849 MHz. The EIRP of mobile transmitters are limited to 2 Watts for 1850~1910 MHz.

3.2.2 Measuring Instruments

See list of measuring instruments of this test report.

3.2.3 Test Procedures

1. The EUT was placed on a turntable with 1.0 meter height in a fully anechoic chamber.
2. The EUT was set at 1.2 meters from the receiving antenna, which was mounted on the antenna tower.
3. The table was rotated 360 degrees to determine the position of the highest radiated power.
4. The height of the receiving antenna is adjusted to look for the maximum ERP/EIRP.
5. Taking the record of maximum ERP/EIRP.
6. A dipole antenna was substituted in place of the EUT and was driven by a signal generator.
7. The conducted power at the terminal of the dipole antenna is measured.
8. Repeat step 3 to step 5 to get the maximum ERP/EIRP of the substitution antenna.
9. $ERP/EIRP = P_s + E_t - E_s + G_s = P_s + R_t - R_s + G_s$

P_s (dBm) : Input power to substitution antenna.

G_s (dBi or dBd) : Substitution antenna Gain.

$E_t = R_t + AF$

$E_s = R_s + AF$

AF (dB/m) : Receive antenna factor

R_t : The highest received signal in spectrum analyzer for EUT.

R_s : The highest received signal in spectrum analyzer for substitution antenna.

3.2.4 Test Setup

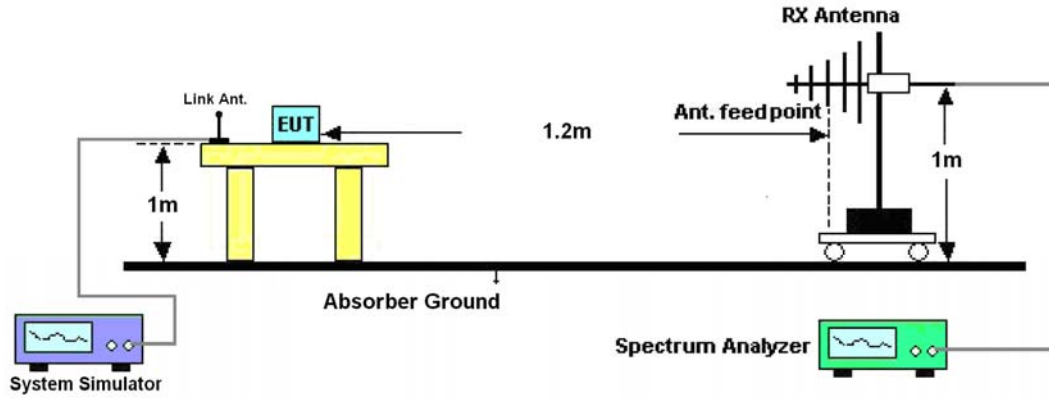

3.2.5 Test Result of ERP

CDMA2000 BC0 1xRTT_RC3+SO32 Radiated Power ERP						
Horizontal Polarization						
Frequency (MHz)	Rt (dBm)	Rs (dBm)	Ps (dBm)	Gs (dBd)	ERP (dBm)	ERP (W)
824.70	-27.57	-48.12	0.00	-1.08	19.47	0.09
836.52	-26.48	-48.28	0.00	-0.93	20.87	0.12
848.31	-26.09	-48.35	0.00	-0.76	21.50	0.14
Vertical Polarization						
Frequency (MHz)	Rt (dBm)	Rs (dBm)	Ps (dBm)	Gs (dBd)	ERP (dBm)	ERP (W)
824.70	-29.35	-47.97	0.00	-1.08	17.54	0.06
836.52	-29.56	-48.01	0.00	-0.93	17.52	0.06
848.31	-29.72	-48.05	0.00	-0.76	17.57	0.06

3.2.6 Test Result of EIRP

CDMA2000 BC1 1xRTT_RC3+SO32 Radiated Power EIRP						
Horizontal Polarization						
Frequency (MHz)	Rt (dBm)	Rs (dBm)	Ps (dBm)	Gs (dBi)	EIRP (dBm)	EIRP (W)
1851.25	-30.20	-51.88	0.00	1.96	23.64	0.23
1880.00	-31.92	-52.99	0.00	2.00	23.07	0.20
1908.75	-33.72	-54.28	0.00	1.98	22.54	0.18
Vertical Polarization						
Frequency (MHz)	Rt (dBm)	Rs (dBm)	Ps (dBm)	Gs (dBi)	EIRP (dBm)	EIRP (W)
1851.25	-30.45	-52.13	0.00	1.96	23.64	0.23
1880.00	-32.10	-53.17	0.00	2.00	23.07	0.20
1908.75	-33.57	-54.13	0.00	1.98	22.54	0.18

3.3 Occupied Bandwidth Measurement

3.3.1 Description of Occupied Bandwidth Measurement

The emission bandwidth is defined as the width of the signal between two points, located at the 2 sides of the carrier frequency, outside of which all emissions are attenuated at least 26 dB below the transmitter power.

3.3.2 Measuring Instruments

See list of measuring instruments of this test report.

3.3.3 Test Procedures

1. The EUT was connected to Spectrum Analyzer and Base Station via power divider.
2. The 99% and 26 dB occupied bandwidth (BW) of the middle channel for the highest RF powers were measured.

3.3.4 Test Setup

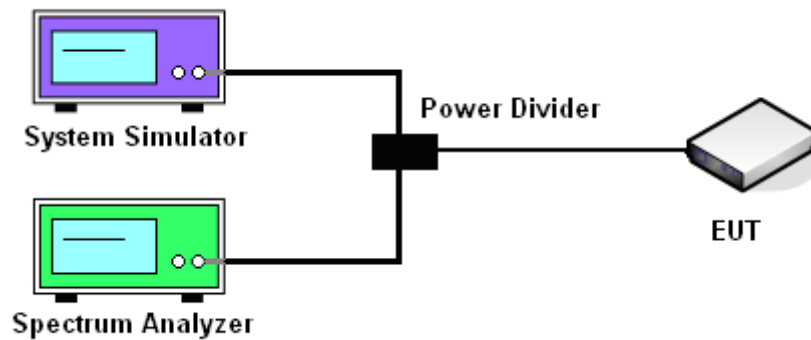



3.3.5 Test Result (Plots) of Occupied Bandwidth

Band :	CDMA2000 BC0	Power Stage :	High
Test Mode :	1xRTT_RC3+SO32		

99% Occupied Bandwidth Plot on Channel 384

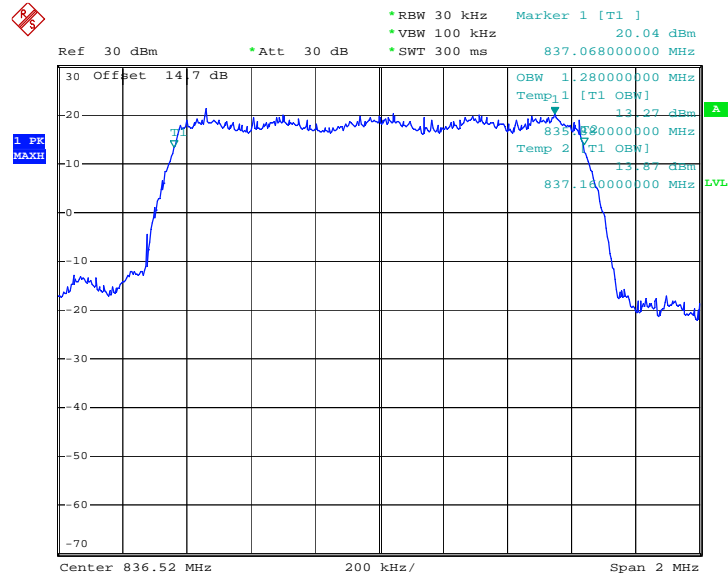

Date: 7.OCT.2011 10:40:11

26dB Bandwidth Plot on Channel 384

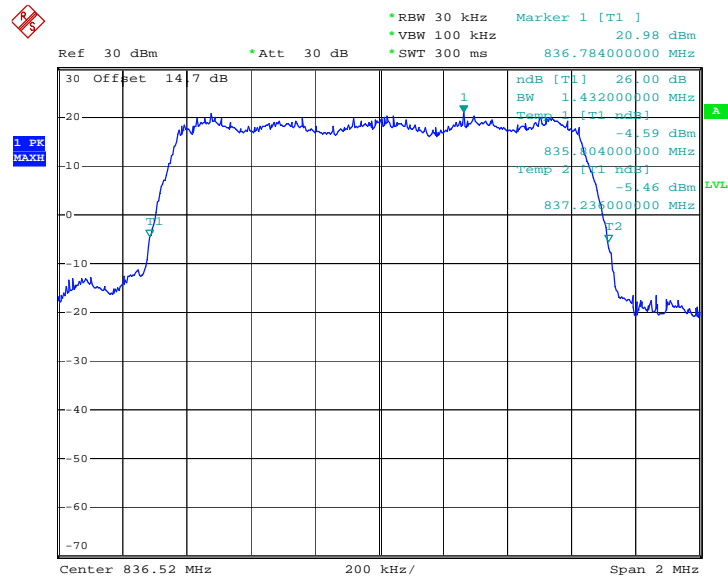

Date: 7.OCT.2011 10:35:21



Band :	CDMA2000 BC1	Power Stage :	High
Test Mode :	1xRTT_RC3+SO32		

99% Occupied Bandwidth Plot on Channel 600

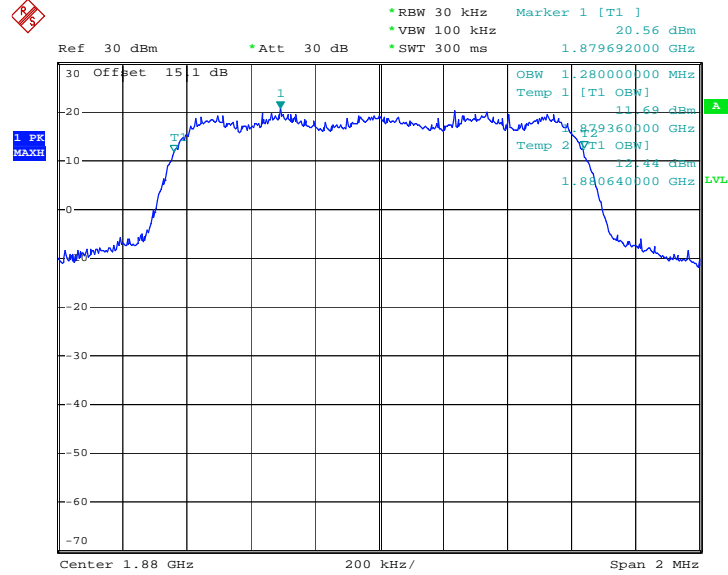

Date: 7.OCT.2011 10:53:07

26dB Bandwidth Plot on Channel 600

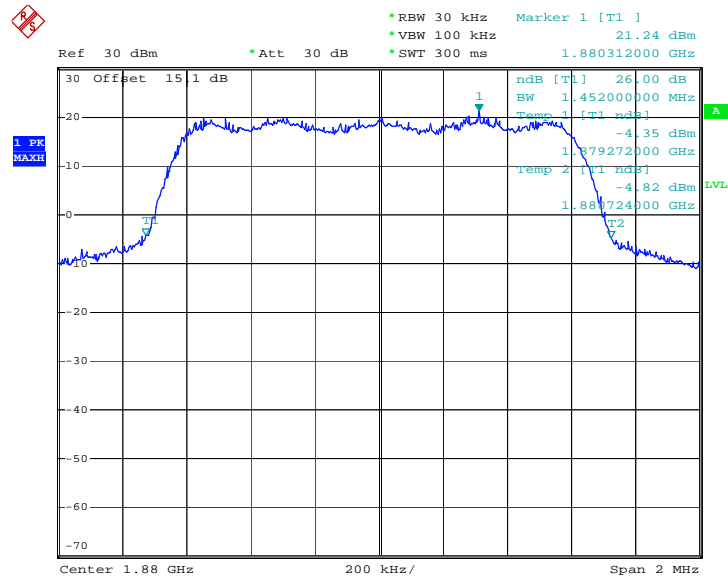

Date: 7.OCT.2011 10:55:36

3.4 Band Edge Measurement

3.4.1 Description of Band Edge Measurement

The power of any emission outside of the authorized operating frequency ranges must be lower than the transmitter power (P) by a factor of at least $43 + 10 \log (P)$ dB.

3.4.2 Measuring Instruments

See list of measuring instruments of this test report.

3.4.3 Test Procedures

1. The EUT was connected to Spectrum Analyzer and Base Station via power divider.
2. The band edges of low and high channels for the highest RF powers were measured. Setting RBW as roughly $BW/100$.
3. The RBW was replaced by 10 kHz, due to the spectrum analyzer IF-Filter including an excess of the limit. A worst case correction factor of $10 \log (1\% BW/\text{measurement RBW})$ was implemented.

3.4.4 Test Setup

<Conducted Band Edge >

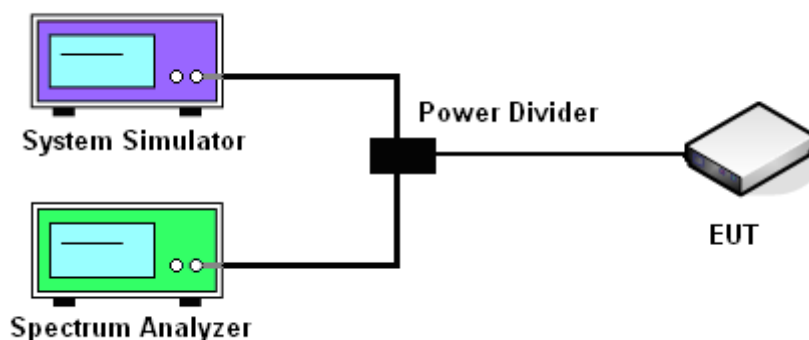



3.4.5 Test Result (Plots) of Conducted Band Edge

Band :	CDMA2000 BC0	Power Stage :	High
Test Mode :	1xRTT_RC3+SO32		

Lower Band Edge Plot on Channel 1013

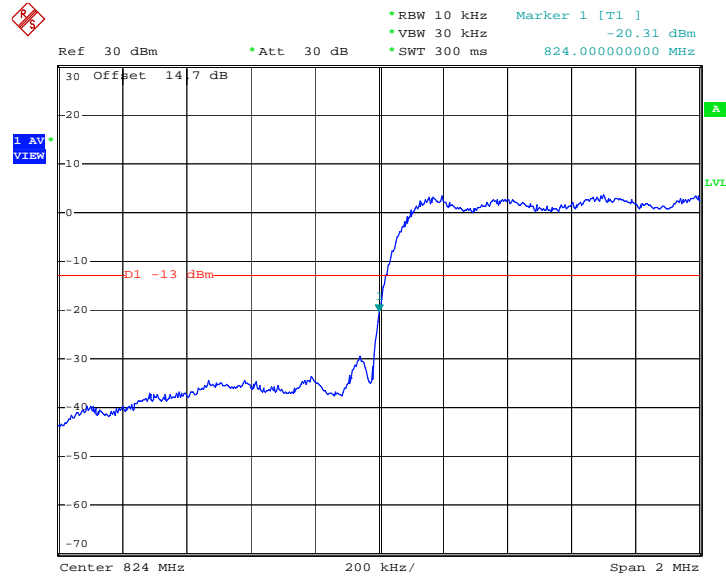

Date: 7.OCT.2011 10:21:17

Higher Band Edge Plot on Channel 777

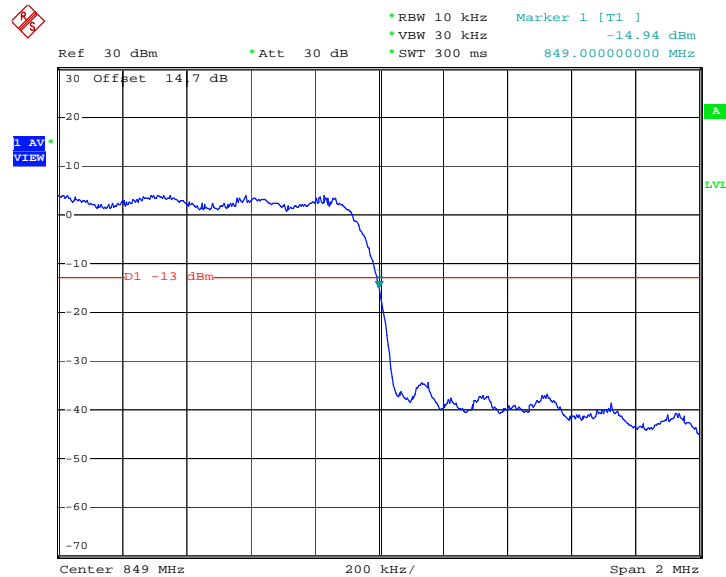

Date: 7.OCT.2011 10:23:18



Band :	CDMA2000 BC1	Power Stage :	High
Test Mode :	1xRTT_RC3+SO32		

Lower Band Edge Plot on Channel 25

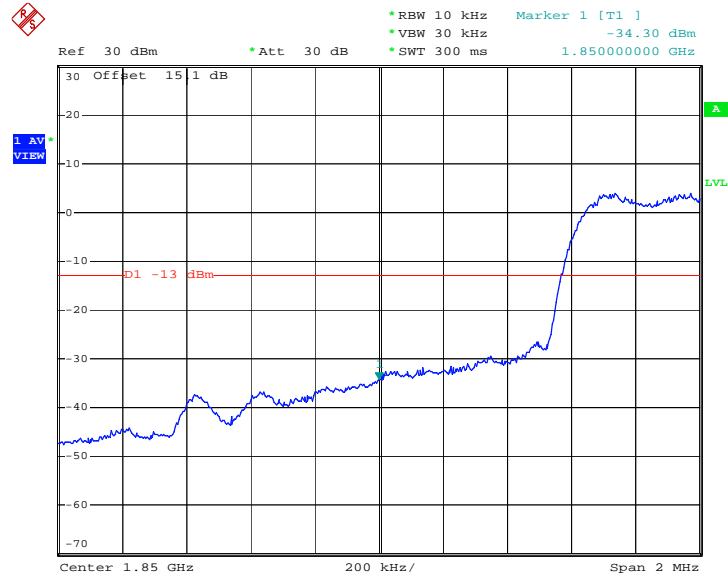

Date: 7.OCT.2011 10:16:11

Higher Band Edge Plot on Channel 1175

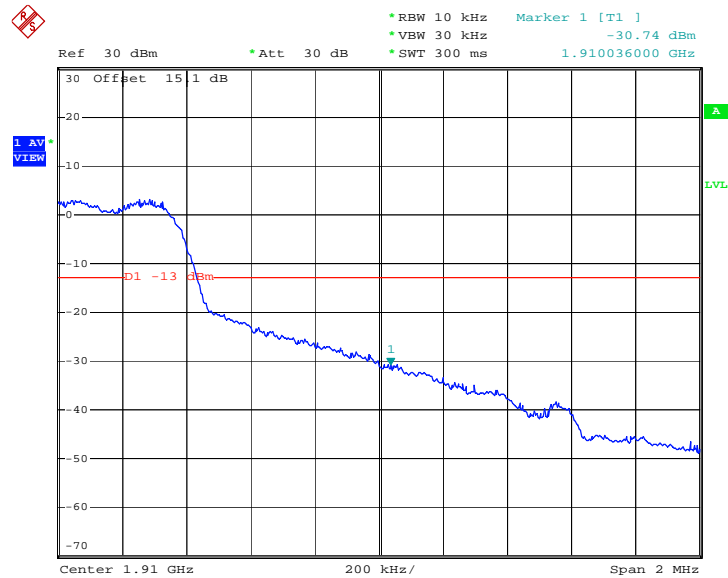

Date: 7.OCT.2011 10:15:00

3.5 Conducted Emission Measurement

3.5.1 Description of Conducted Emission Measurement

The power of any emission outside of the authorized operating frequency ranges must be lower than the transmitter power (P) by a factor of at least $43 + 10 \log (P)$ dB.

It is measured by means of a calibrated spectrum analyzer and scanned from 30 MHz up to a frequency including its 10th harmonic.

3.5.2 Measuring Instruments

See list of measuring instruments of this test report.

3.5.3 Test Procedures

1. The EUT was connected to spectrum analyzer and base station via power divider.
2. The middle channel for the highest RF power within the transmitting frequency was measured.
3. The conducted spurious emission for the whole frequency range was taken.

3.5.4 Test Setup

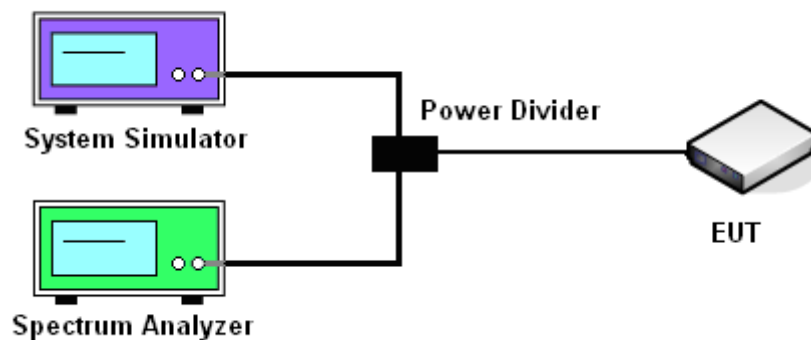



3.5.5 Test Result (Plots) of Conducted Emission

Band :	CDMA2000 BC0	Power Stage :	High
Test Mode :	1xRTT_RC3+SO32		

Conducted Emission Plot between 30MHz ~ 1GHz

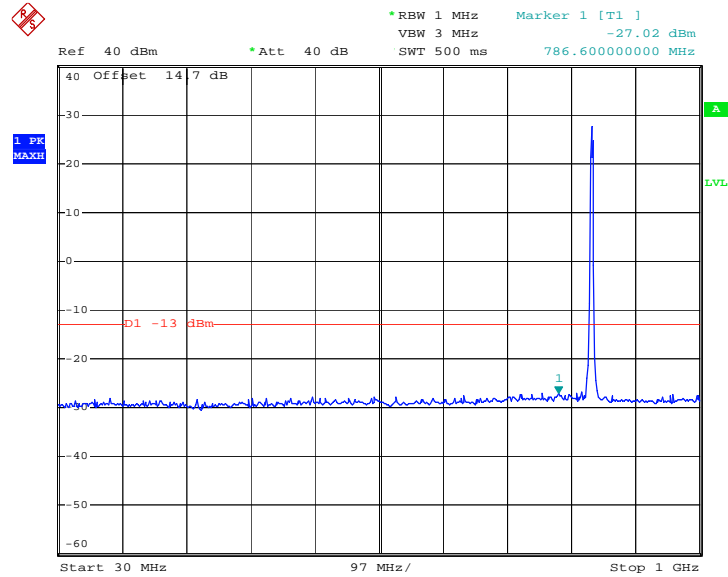

Date: 7.OCT.2011 11:14:31

Conducted Emission Plot between 1GHz ~ 3GHz

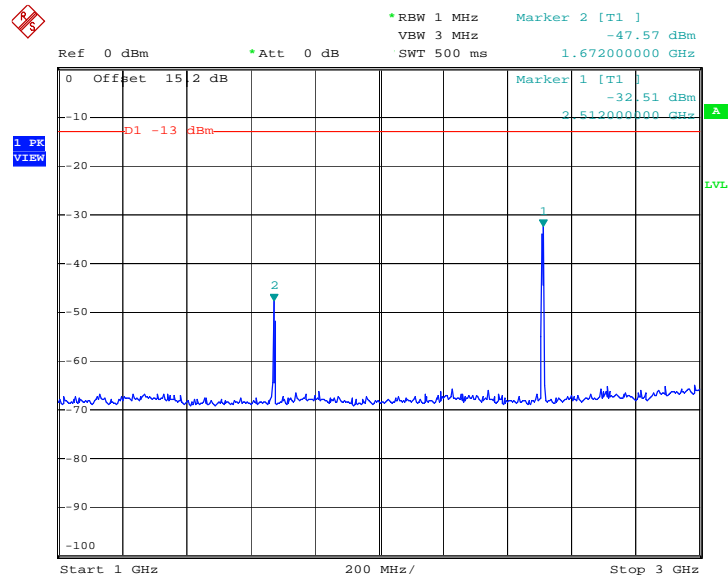

Date: 7.OCT.2011 11:15:48



Conducted Emission Plot between 3GHz ~ 7GHz

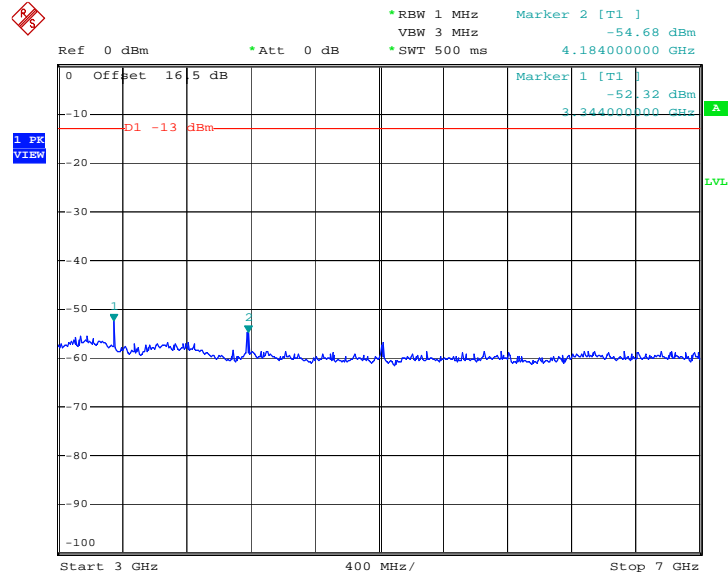

Date: 7.OCT.2011 11:16:54

Conducted Emission Plot between 7GHz ~ 9GHz

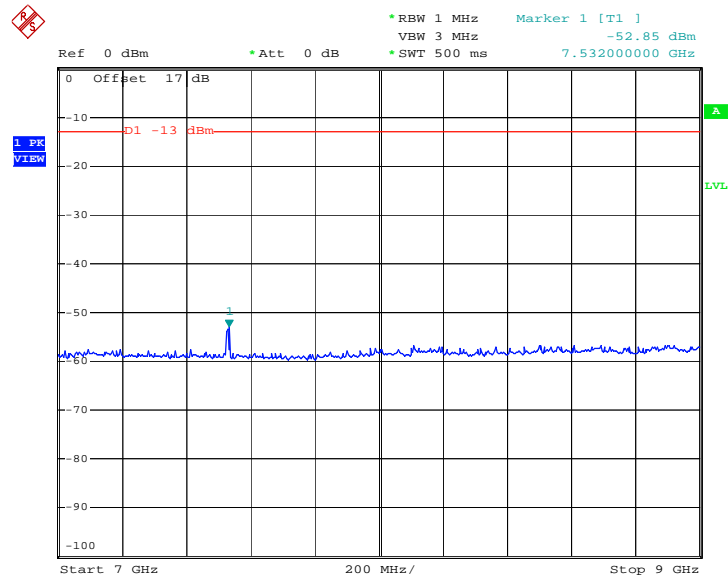

Date: 7.OCT.2011 11:19:53



Band :	CDMA2000 BC1	Power Stage :	High
Test Mode :	1xRTT_RC3+SO32		

Conducted Emission Plot between 30MHz ~ 1GHz

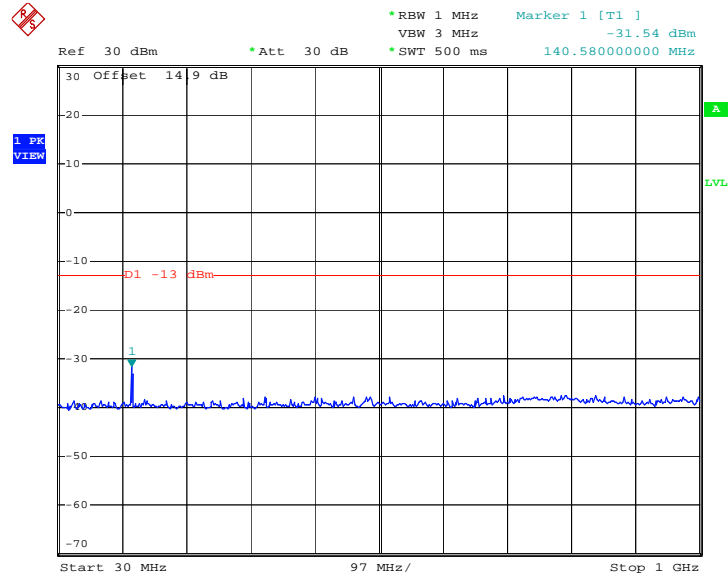

Date: 7.OCT.2011 11:02:55

Conducted Emission Plot between 1GHz ~ 3GHz

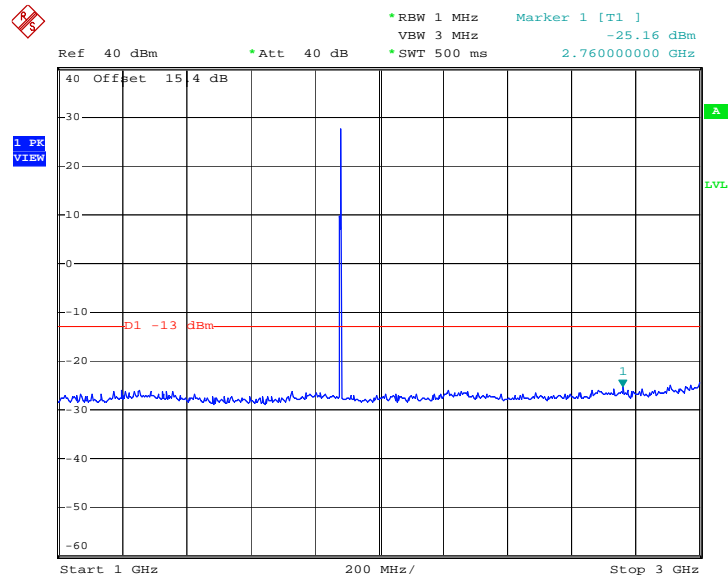

Date: 7.OCT.2011 11:05:10



Conducted Emission Plot between 3GHz ~ 7GHz

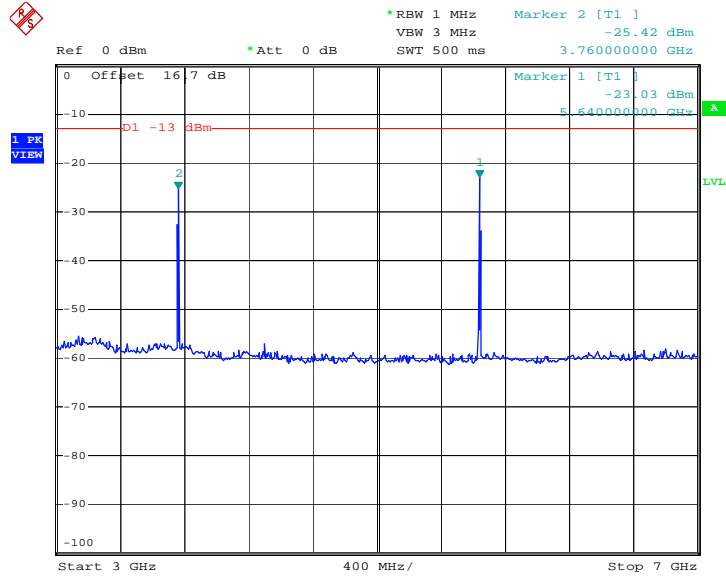

Date: 7.OCT.2011 11:06:40

Conducted Emission Plot between 7GHz ~ 13.6GHz

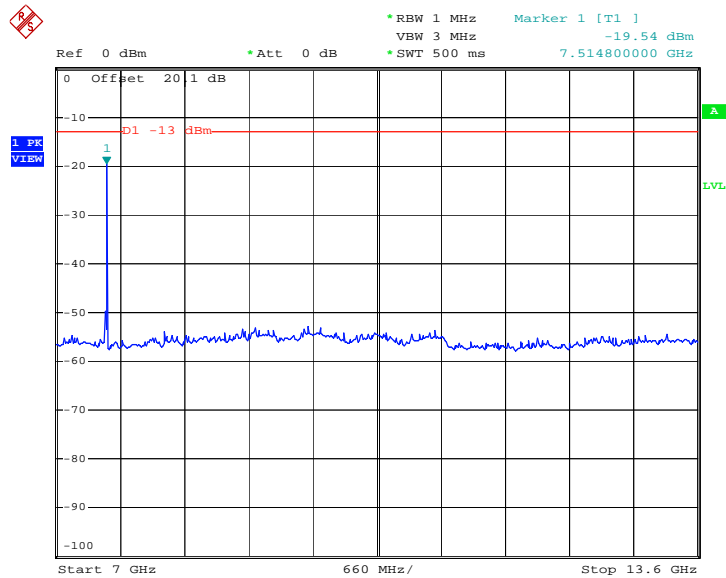

Date: 7.OCT.2011 11:07:50



Conducted Emission Plot between 13.6GHz ~ 19.1GHz

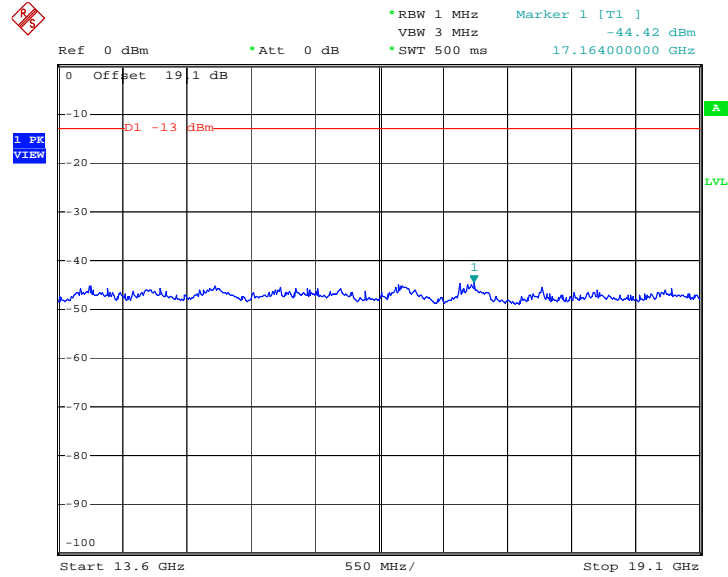

Date: 7.OCT.2011 11:09:16

3.6 Field Strength of Spurious Radiation Measurement

3.6.1 Description of Field Strength of Spurious Radiated Measurement

The radiated spurious emission was measured by substitution method according to ANSI / TIA / EIA-603-C-2004. The power of any emission outside of the authorized operating frequency ranges must be attenuated below the transmitter power (P) by a factor of at least $43 + 10 \log (P)$ dB. The spectrum is scanned from 30 MHz up to a frequency including its 10th harmonic.

3.6.2 Measuring Instruments

See list of measuring instruments of this test report.

3.6.3 Test Procedures

1. The EUT was placed on a rotatable wooden table with 0.8 meter about ground.
2. The EUT was set 3 meters from the receiving antenna, which was mounted on the antenna tower.
3. The table was rotated 360 degrees to determine the position of the highest spurious emission.
4. The height of the receiving antenna is varied between one meter and four meters to search the maximum spurious emission for both horizontal and vertical polarizations.
5. Taking the record of maximum spurious emission.
6. A horn antenna was substituted in place of the EUT and was driven by a signal generator.
7. Tune the output power of signal generator to the same emission level with EUT maximum spurious emission.
8. Taking the record of output power at antenna port.
9. Repeat step 7 to step 8 for another polarization.
10. $EIRP \text{ (dBm)} = S.G. \text{ Power} - Tx \text{ Cable Loss} + Tx \text{ Antenna Gain}$
11. $ERP \text{ (dBm)} = EIRP - 2.15$

3.6.4 Test Setup

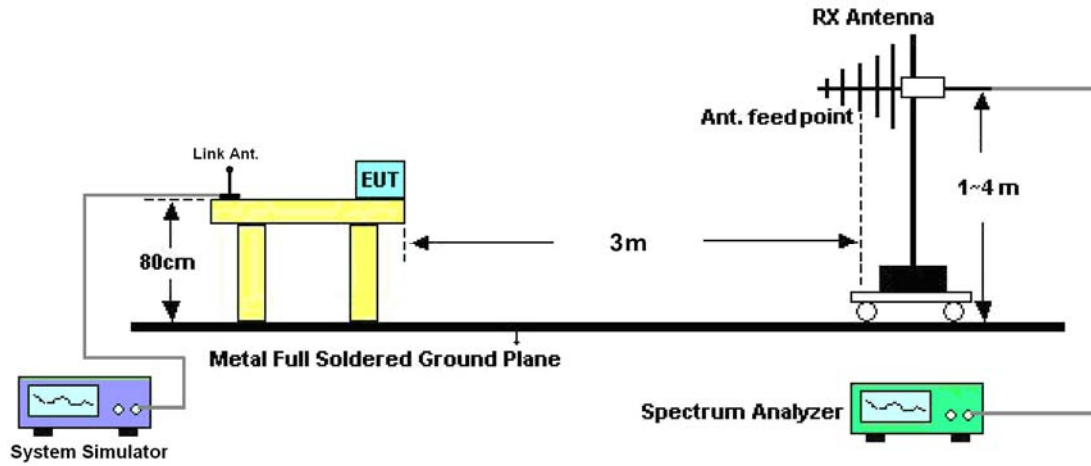



3.6.5 Test Result of Field Strength of Spurious Radiated

Band :	CDMA2000 BC0	Temperature :	21~22°C
Test Mode :	1xRTT_RC3+SO32	Relative Humidity :	40~41%
Test Engineer :	Jack Li	Polarization :	Horizontal
Remark :	Spurious emissions within 30-1000MHz were found more than 20dB below limit line.		

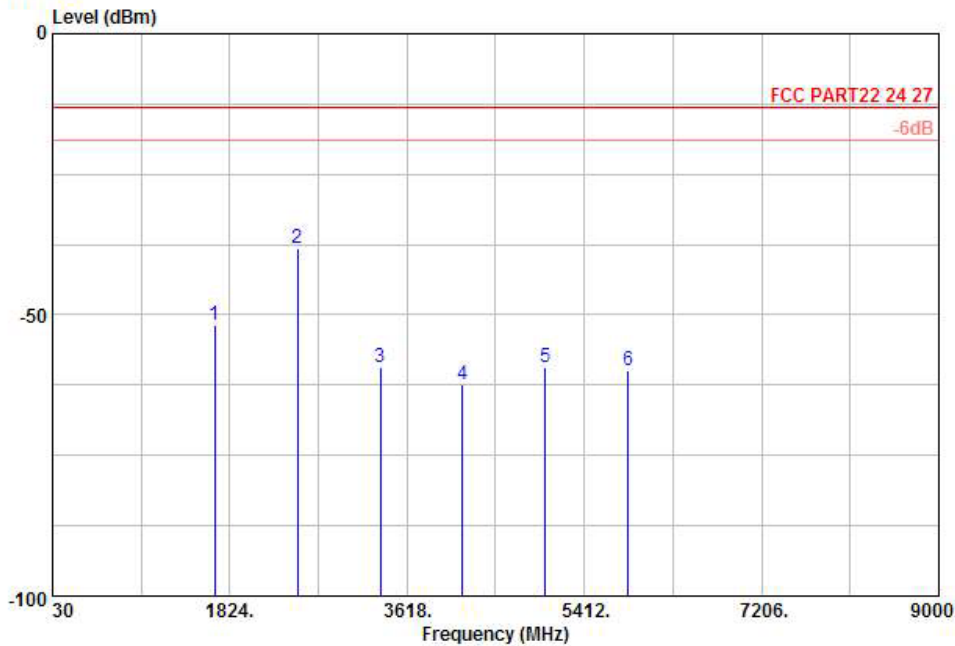

Site : 03CH01-KS
 Condition: FCC PART22 24 27 HF EIRP FACTOR-09020 HORIZONTAL
 Project : (FG) 190809

Frequency (MHz)	ERP (dBm)	Limit (dBm)	Over Limit (dB)	SPA Reading (dBm)	S.G. Power (dBm)	TX Cable loss (dB)	TX Antenna Gain (dBi)	Polarization (H/V)	Result
1672	-51.81	-13	-38.81	-50.11	-52.46	0.57	3.37	H	Pass
2509	-38.04	-13	-25.04	-42.39	-40.27	0.78	5.16	H	Pass
3346	-59.42	-13	-46.42	-61.36	-63.06	0.87	6.66	H	Pass
4182	-62.49	-13	-49.49	-65.23	-67.08	0.97	7.71	H	Pass
5018	-59.21	-13	-46.21	-65.41	-64.88	1.09	8.91	H	Pass
5854	-59.77	-13	-46.77	-68.48	-66.21	1.22	9.81	H	Pass



Band :	CDMA2000 BC0	Temperature :	21~22°C
Test Mode :	1xRTT_RC3+SO32	Relative Humidity :	40~41%
Test Engineer :	Jack Li	Polarization :	Vertical
Remark :	Spurious emissions within 30-1000MHz were found more than 20dB below limit line.		

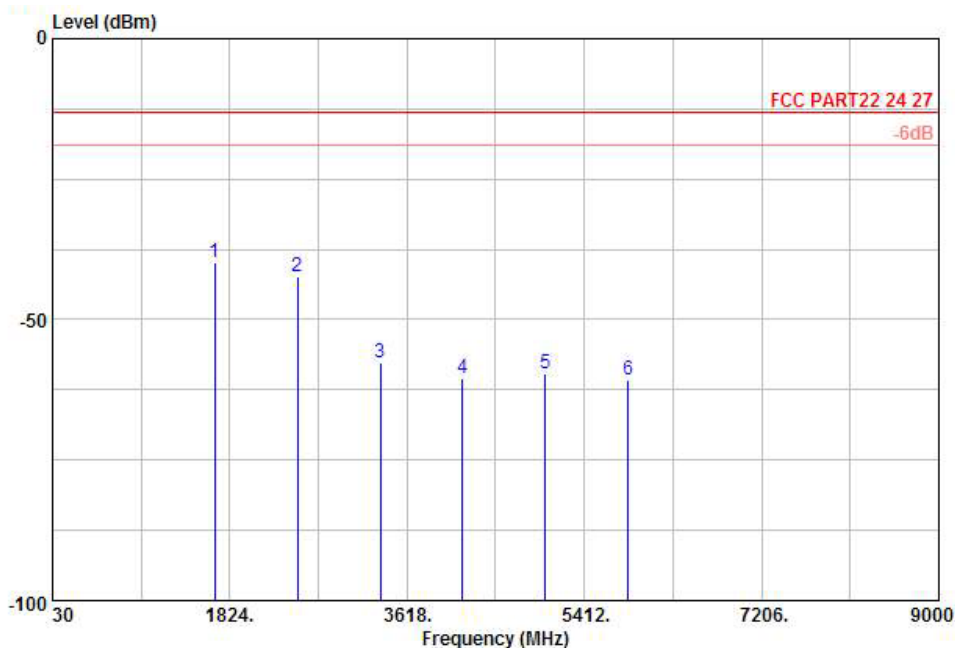

Site : 03CH01-KS
 Condition: FCC PART22 24 27 HF EIRP FACTOR-09020 VERTICAL
 Project : (FG) 190809

Frequency (MHz)	ERP (dBm)	Limit (dBm)	Over Limit (dB)	SPA Reading (dBm)	S.G. Power (dBm)	TX Cable loss (dB)	TX Antenna Gain (dBi)	Polarization (H/V)	Result
1672	-39.94	-13	-26.94	-44.75	-40.59	0.57	3.37	V	Pass
2509	-42.45	-13	-29.45	-47.97	-44.68	0.78	5.16	V	Pass
3346	-57.61	-13	-44.61	-59.59	-61.25	0.87	6.66	V	Pass
4182	-60.50	-13	-47.50	-64.34	-65.09	0.97	7.71	V	Pass
5018	-59.66	-13	-46.66	-64.60	-65.33	1.09	8.91	V	Pass
5854	-60.67	-13	-47.67	-68.66	-67.11	1.22	9.81	V	Pass



Band :	CDMA2000 BC1	Temperature :	21~22°C
Test Mode :	1xRTT_RC3+SO32	Relative Humidity :	40~41%
Test Engineer :	Jack Li	Polarization :	Horizontal
Remark :	Spurious emissions within 30-1000MHz were found more than 20dB below limit line.		

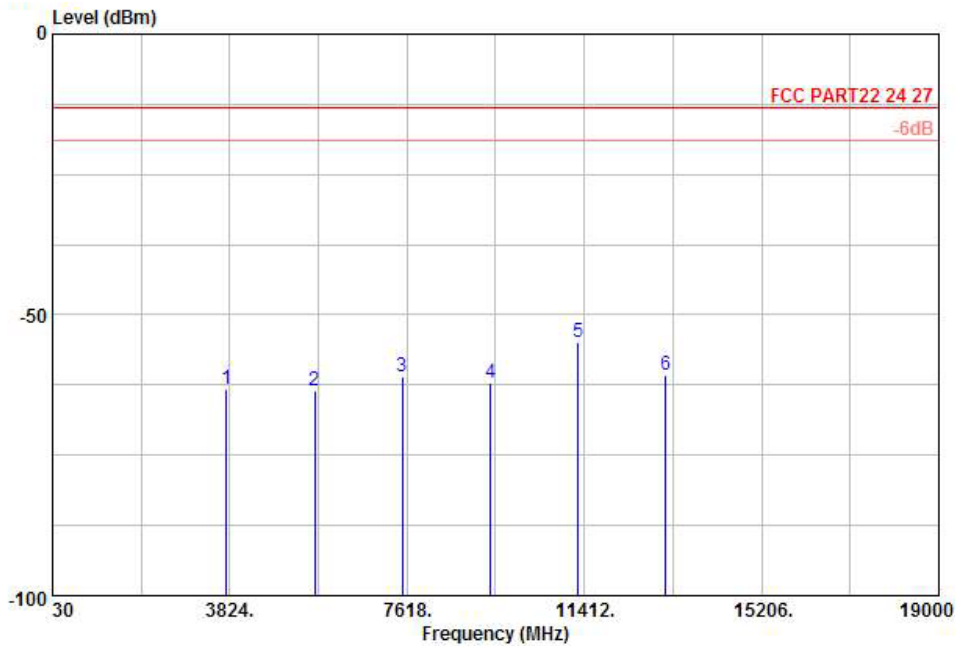

Site : 03CH01-KS
 Condition: FCC PART22 24 27 HF EIRP FACTOR-09020 HORIZONTAL
 Project : (FG) 190809

Frequency (MHz)	EIRP (dBm)	Limit (dBm)	Over Limit (dB)	SPA Reading (dBm)	S.G. Power (dBm)	TX Cable loss (dB)	TX Antenna Gain (dBi)	Polarization (H/V)	Result
3760	-63.32	-13	-50.32	-64.29	-69.70	0.78	7.16	H	Pass
5640	-63.51	-13	-50.51	-67.69	-72.05	1.04	9.58	H	Pass
7520	-61.12	-13	-48.12	-66.25	-71.23	1.35	11.46	H	Pass
9400	-62.17	-13	-49.17	-65.43	-73.23	1.75	12.81	H	Pass
11280	-54.88	-13	-41.88	-66.37	-65.97	2	13.09	H	Pass
13160	-60.78	-13	-47.78	-72.08	-72.49	2.04	13.75	H	Pass



Band :	CDMA2000 BC1	Temperature :	21~22°C
Test Mode :	1xRTT_RC3+SO32	Relative Humidity :	40~41%
Test Engineer :	Jack Li	Polarization :	Vertical
Remark :	Spurious emissions within 30-1000MHz were found more than 20dB below limit line.		

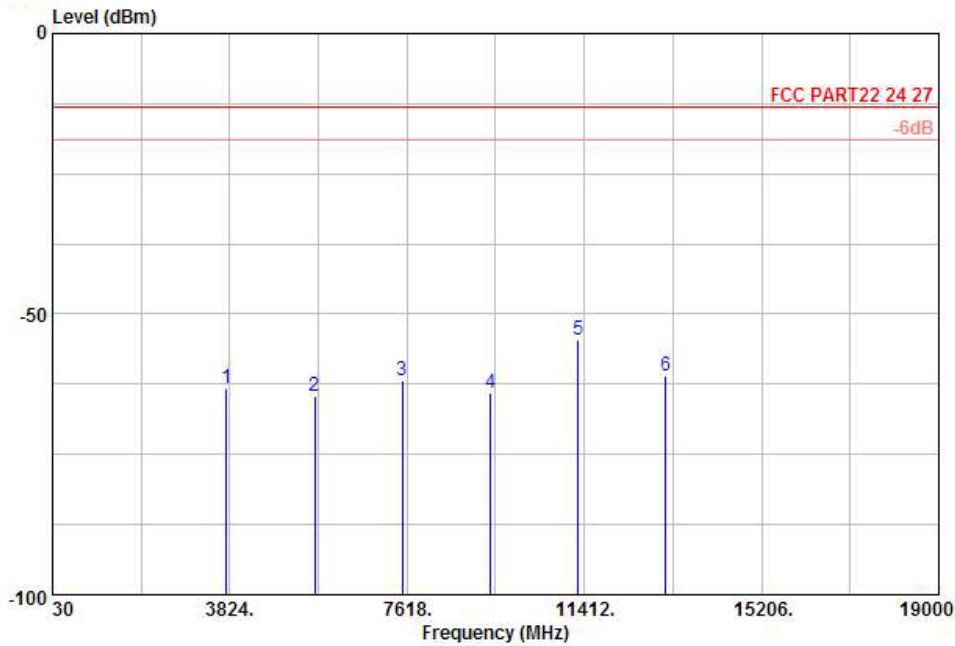

Site : 03CH01-KS
 Condition: FCC PART22 24 27 HF EIRP FACTOR-09020 VERTICAL
 Project : (FG) 190809

Frequency (MHz)	EIRP (dBm)	Limit (dBm)	Over Limit (dB)	SPA Reading (dBm)	S.G. Power (dBm)	TX Cable loss (dB)	TX Antenna Gain (dBi)	Polarization (H/V)	Result
3760	-63.36	-13	-50.36	-64.73	-69.74	0.78	7.16	V	Pass
5640	-64.59	-13	-51.59	-67.81	-73.13	1.04	9.58	V	Pass
7520	-61.95	-13	-48.95	-66.44	-72.06	1.35	11.46	V	Pass
9400	-64.03	-13	-51.03	-65.25	-75.09	1.75	12.81	V	Pass
11280	-54.67	-13	-41.67	-65.91	-65.76	2	13.09	V	Pass
13160	-61.06	-13	-48.06	-72.25	-72.77	2.04	13.75	V	Pass

3.7 Frequency Stability Measurement

3.7.1 Description of Frequency Stability Measurement

The frequency stability shall be measured by variation of ambient temperature and variation of primary supply voltage to ensure that the fundamental emission stays within the authorized frequency block. The frequency stability of the transmitter shall be maintained within $\pm 0.00025\%$ ($\pm 2.5\text{ppm}$) of the center frequency.

3.7.2 Measuring Instruments

See list of measuring instruments of this test report.

3.7.3 Test Procedures for Temperature Variation

1. The EUT was set up in the thermal chamber and connected with the base station.
2. With power OFF, the temperature was decreased to -30°C and the EUT was stabilized for three hours. Power was applied and the maximum change in frequency was recorded within one minute.
3. With power OFF, the temperature was raised in 10°C step up to 50°C . The EUT was stabilized at each step for at least half an hour. Power was applied and the maximum frequency change was recorded within one minute.
4. If the EUT cannot be turned on at -30°C , the testing lowest temperature will be raised in 10°C step until the EUT can be turned on.

3.7.4 Test Procedures for Voltage Variation

1. The EUT was placed in a temperature chamber at $25\pm 5^{\circ}\text{C}$ and connected with the base station.
2. The power supply voltage to the EUT was varied from BEP to 115% of the nominal value measured at the input to the EUT.
3. The variation in frequency was measured for the worst case.

3.7.5 Test Setup

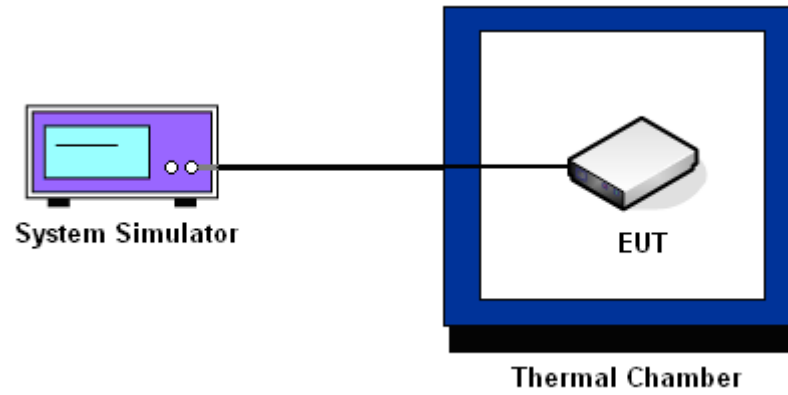



3.7.6 Test Result of Temperature Variation

Band :	CDMA2000 BC0	Channel :	384
Test Mode :	1xRTT_RC3+SO32	Limit (ppm) :	2.5

Temperature (°C)	Freq. Dev. (Hz)	Deviation (ppm)	Result
-30	NA	NA	PASS
-20	NA	NA	
-10	NA	NA	
0	-6	-0.01	
10	5	0.01	
20	-5	-0.01	
30	-6	-0.01	
40	-7	-0.01	
50	-8	-0.01	

Note: The manufacturer declared that the EUT could work properly between temperatures 0°C~50°C.

Band :	CDMA2000 BC1	Channel :	600
Test Mode :	1xRTT_RC3+SO32	Limit (ppm) :	2.5

Temperature (°C)	Freq. Dev. (Hz)	Deviation (ppm)	Result
-30	NA	NA	PASS
-20	NA	NA	
-10	NA	NA	
0	12	0.01	
10	12	0.01	
20	11	0.01	
30	-10	-0.01	
40	-11	-0.01	
50	-12	-0.01	

Note: The manufacturer declared that the EUT could work properly between temperatures 0°C~50°C.

3.7.7 Test Result of Voltage Variation

Band & Channel	Mode	Voltage (Volt)	Freq. Dev. (Hz)	Deviation (ppm)	Limit (ppm)	Result
CDMA2000 BC0 CH384	1xRTT RC3+SO32	7.4	-8	-0.01	2.5	PASS
		BEP	-7	-0.01		
		11.4	-6	-0.01		
CDMA2000 BC1 CH600	1xRTT RC3+SO32	7.4	-10	-0.01	2.5	PASS
		BEP	-12	-0.01		
		11.4	-11	-0.01		

Note :

1. Normal Voltage = 7.4V.
2. Battery End Point (BEP) = 6.8 V.

4 List of Measuring Equipments

Instrument	Manufacturer	Model No.	Serial No.	Characteristics	Calibration Date	Due Date	Remark
Spectrum Analyzer	R&S	FSP40	100319	9kHz~40GHz	Jan. 07, 2011	Jan. 06, 2012	Conducted (TH01-KS)
System Simulator	R&S	CMU200	837587/066	Full-Band	Jan. 07, 2011	Jan. 06, 2012	Conducted (TH01-KS)
DC Power Supply	TOPWARD	GPS-3030D	E1884515	N/A	Aug. 23, 2011	Aug. 22, 2012	Conducted (TH01-KS)
Thermal Chamber	Ten Billion	TTC-B3S	TBN-960502	N/A	Jan. 17, 2011	Jan. 16, 2012	Conducted (TH01-KS)
EMI Test Receiver	R&S	ESCI	100534	9kHz~3GHz	Nov. 16, 2010	Nov. 15, 2011	Radiation (03CH01-KS)
Spectrum Analyzer	R&S	FSP40	100319	9kHz~40GHz	Jan. 07, 2011	Jan. 06, 2012	Radiation (03CH01-KS)
Bilog Antenna	SCHAFFNER	CBL6112D	23182	25MHz~2GHz	Dec. 07, 2010	Dec. 06, 2011	Radiation (03CH01-KS)
Double Ridge Horn Antenna	EMCO	3117	00075959	1GHz~18GHz	Jan. 07, 2011	Jan. 06, 2012	Radiation (03CH01-KS)
Amplifier	Wireless	FPA-6592G	060004	30MHz~2GHz	Dec. 09, 2010	Dec. 08, 2011	Radiation (03CH01-KS)
Active Horn Antenna	com-power	AHA-118	701023	1GHz~18GHz	Nov. 09, 2010	Nov. 08, 2011	Radiation (03CH01-KS)
SHE-EHF Horn	Schwarzbeck	BBHA9170	BBHA170249	15GHz~40GHz	Oct. 15, 2010	Oct. 14, 2011	Radiation (03CH01-KS)
System Simulator	R&S	CMU200	837587/066	Full-Band	Jan. 07, 2011	Jan. 06, 2012	Radiation (03CH01-KS)

5 Uncertainty of Evaluation

Uncertainty of Radiated Emission Measurement (30 MHz ~ 1000 MHz)

Contribution	Uncertainty of X_i		$u(X_i)$
	dB	Probability Distribution	
Receiver Reading	0.41	Normal (k=2)	0.21
Antenna Factor Calibration	0.83	Normal (k=2)	0.42
Cable Loss Calibration	0.25	Normal (k=2)	0.13
Pre-Amplifier Gain Calibration	0.27	Normal (k=2)	0.14
RCV/SPA Specification	2.50	Rectangular	0.72
Antenna Factor Interpolation for Frequency	1.00	Rectangular	0.29
Site Imperfection	1.43	Rectangular	0.83
Mismatch	+0.39 / -0.41	U-Shape	0.28
Combined Standard Uncertainty $U_c(y)$	1.27		
Measuring Uncertainty for a Level of Confidence of 95% ($U = 2U_c(y)$)	2.54		

Uncertainty of Radiated Emission Measurement (1 GHz ~ 40 GHz)

Contribution	Uncertainty of X_i		$u(X_i)$	C_i	$C_i * u(X_i)$
	dB	Probability Distribution			
Receiver Reading	± 0.10	Normal (k=2)	0.10	1	0.10
Antenna Factor Calibration	± 1.70	Normal (k=2)	0.85	1	0.85
Cable Loss Calibration	± 0.50	Normal (k=2)	0.25	1	0.25
Receiver Correction	± 2.00	Rectangular	1.15	1	1.15
Antenna Factor Directional	± 1.50	Rectangular	0.87	1	0.87
Site Imperfection	± 2.80	Triangular	1.14	1	1.14
Mismatch Receiver VSWR $\Gamma_1 = 0.197$ Antenna VSWR $\Gamma_2 = 0.194$ Uncertainty = $20\text{Log}(1-\Gamma_1*\Gamma_2)$	+0.34 / -0.35	U-Shape	0.244	1	0.244
Combined Standard Uncertainty $U_c(y)$	2.36				
Measuring Uncertainty for a Level of Confidence of 95% ($U = 2U_c(y)$)	4.72				



Appendix A. Photographs of EUT

Please refer to Sporton report number EP190809 as below.