

FCC TEST REPORT (PART 27)



Applicant:	PAX Technology Limited
Address:	Room 2416, 24/F., Sun Hung Kai Centre, 30 Harbour Hong Kong China

Manufacturer or Supplier:	PAX Computer Technology (Shenzhen) Co., Ltd.
Address:	4/F, No.3 Building, Software Park, Second Central Science-Tech Road, High-Tech industrial Park, Shenzhen, Guangdong, P.R.C.
Product:	Pay Tablet
Brand Name:	PAX
Model Name:	M8
FCC ID:	V5PM8
Date of tests:	Sep. 19, 2021 ~ Oct. 30, 2021

The tests have been carried out according to the requirements of the following standard:

- FCC Part 27, Subpart C, M ANSI/TIA/EIA-603-D
 FCC Part 2 ANSI/TIA/EIA-603-E ANSI C63.26-2015

CONCLUSION: The submitted sample was found to COMPLY with the test requirement

Prepared by Simon Wang Engineer / Mobile Department	Approved by Luke Lu Manager / Mobile Department
	
Date: Nov. 01, 2021	Date: Nov. 01, 2021

This report is governed by, and incorporates by reference, CPS Conditions of Service as posted at the date of issuance of this report at <http://www.bureauveritas.com/home/about-us/our-business/cps/about-us/terms-conditions> and is intended for your exclusive use. Any copying or replication of this report to or for any other person or entity, or use of our name or trademark, is permitted only with our prior written permission. This report sets forth our findings solely with respect to the test samples identified herein. The results set forth in this report are not indicative or representative of the quality or characteristics of the lot from which a test sample was taken or any similar or identical product unless specifically and expressly noted. Our report includes all of the tests requested by you and the results thereof based upon the information that you provided to us. Measurement uncertainty is only provided upon request for accredited tests. You have 60 days from date of issuance of this report to notify us of any material error or omission caused by our negligence or if you require measurement uncertainty; provided, however, that such notice shall be in writing and shall specifically address the issue you wish to raise. A failure to raise such issue within the prescribed time shall constitute your unqualified acceptance of the completeness of this report, the tests conducted and the correctness of the report contents.



TABLE OF CONTENTS

RELEASE CONTROL RECORD 4

1 SUMMARY OF TEST RESULTS 5

1.1 MEASUREMENT UNCERTAINTY 5

1.2 TEST SITE AND INSTRUMENTS 6

2 GENERAL INFORMATION 7

2.1 GENERAL DESCRIPTION OF EUT 7

2.2 CONFIGURATION OF SYSTEM UNDER TEST 10

2.3 DESCRIPTION OF SUPPORT UNITS 11

2.4 TEST ITEM AND TEST CONFIGURATION 11

2.5 GENERAL DESCRIPTION OF APPLIED STANDARDS 18

3 TEST TYPES AND RESULTS 19

3.1 OUTPUT POWER MEASUREMENT 19

3.1.1 LIMITS OF OUTPUT POWER MEASUREMENT 19

3.1.2 TEST PROCEDURES 19

3.1.3 TEST SETUP 20

3.1.4 TEST RESULTS 20

3.2 FREQUENCY STABILITY MEASUREMENT 35

3.2.1 LIMITS OF FREQUENCY STABILITY MEASUREMENT 35

3.2.2 TEST PROCEDURE 35

3.2.3 TEST SETUP 35

3.2.4 TEST RESULTS 36

3.3 OCCUPIED BANDWIDTH MEASUREMENT 37

3.3.1 LIMITS OF OCCUPIED BANDWIDTH MEASUREMENT 37

3.3.2 TEST SETUP 37

3.3.3 TEST PROCEDURES 37

3.3.4 TEST RESULTS 38

3.4 BAND EDGE MEASUREMENT 39

3.4.1 LIMITS OF BAND EDGE MEASUREMENT 39

3.4.2 TEST SETUP 39

3.4.3 TEST PROCEDURES 40

3.4.4 TEST RESULTS 41

3.5 CONDUCTED SPURIOUS EMISSIONS 42

3.5.1 LIMITS OF CONDUCTED SPURIOUS EMISSIONS MEASUREMENT 42

3.5.2 TEST PROCEDURE 42

3.5.3 TEST SETUP 42

3.5.4 TEST RESULTS 43

3.6 RADIATED EMISSION MEASUREMENT 44

3.6.1 LIMITS OF RADIATED EMISSION MEASUREMENT 44

3.6.2 TEST PROCEDURES 44

3.6.3 DEVIATION FROM TEST STANDARD 44

3.6.4 TEST SETUP 45

3.6.5 TEST RESULTS 46

3.7 PEAK TO AVERAGE RATIO 98

3.7.1 LIMITS OF PEAK TO AVERAGE RATIO MEASUREMENT 98

3.7.2 TEST SETUP 98

3.7.3 TEST PROCEDURES 98

3.7.4 TEST RESULTS 99



**BUREAU
VERITAS**

Test Report No.: W7L-P21090022RF06

4 INFORMATION ON THE TESTING LABORATORIES	100
5 APPENDIX A 3 – MODIFICATIONS RECORDERS FOR ENGINEERING CHANGES TO THE EUT BY THE LAB	101



Test Report No.: W7L-P21090022RF06

RELEASE CONTROL RECORD

ISSUE NO.	REASON FOR CHANGE	DATE ISSUED
W7L-P21090022RF06	Original release	Nov. 01, 2021

1 SUMMARY OF TEST RESULTS

The EUT has been tested according to the following specifications:

APPLIED STANDARD: FCC Part 27 & Part 2		
STANDARD SECTION	TEST TYPE AND LIMIT	RESULT
2.1046 27.50(h)(2)	Equivalent Isotropically Radiated Power	Compliance
2.1055 27.54	Frequency Stability	Compliance
2.1049 27.53(m)(6)	Occupied Bandwidth	Compliance
2.1051 27.53(m)(4)(6)	Band Edge Measurements	Compliance
2.1051 27.53(m)(4)(6)	Conducted Spurious Emissions	Compliance
2.1053 27.53(m)(4)(6)	Radiated Spurious Emissions	Compliance

1.1 MEASUREMENT UNCERTAINTY

Where relevant, the following measurement uncertainty levels have been estimated for tests performed on the EUT as specified in CISPR 16-4-2:

MEASUREMENT	UNCERTAINTY
Frequency Stability	$\pm 76.97\text{Hz}$
Radiated emissions & Radiated Power (30MHz~1GMHz)	$\pm 4.98\text{dB}$
Radiated emissions & Radiated Power (1GMHz ~6GMHz)	$\pm 4.70\text{dB}$
Radiated emissions (6GMHz ~18GMHz)	$\pm 4.60\text{dB}$
Radiated emissions (18GMHz ~40GMHz)	$\pm 4.12\text{dB}$
Conducted emissions	$\pm 4.01\text{dB}$
Occupied Channel Bandwidth	$\pm 43.58\text{KHz}$
Conducted Output power	$\pm 2.06\text{dB}$
Band Edge Measurements	$\pm 4.70\text{dB}$

This uncertainty represents an expanded uncertainty expressed at approximately the 95% confidence level using a coverage factor of $k=2$.



BUREAU
VERITAS

Test Report No.: W7L-P21090022RF06

1.2 TEST SITE AND INSTRUMENTS

Equipment	Manufacturer	Model No.	Serial No.	Last Cal.	Next Cal.
MXE EMI Receiver	KEYSIGHT	N9038A-544	MY54450026	Apr. 22,21	Apr. 21,22
EXA Signal Analyzer	KEYSIGHT	N9010A-544	MY54510355	Jun. 03,21	Jun. 02,22
Bilog Antenna	ETS-LINDGREN	3143B	00161965	Mar. 05,21	Mar. 04,22
Horn Antenna	ETS-LINDGREN	3117	00168728	Apr. 02,21	Apr. 01,22
Horn Antenna (18GHz-40GHz)	N/A	QWH-SL-18-40-K-SG/QMS-00361	15433	Aug. 25, 21	Aug. 24, 22
Radio Communication Analyzer	ANRITSU	MT8820C	6201465426	Feb. 25,21	Feb. 24,22
Signal Pre-Amplifier	EMSI	EMC 9135	980249	Jun. 02,21	Jun. 01,22
Signal Pre-Amplifier	EMSI	EMC 012645B	980257	Jun. 03,21	Jun. 02,22
Signal Pre-Amplifier	EMSI	EMC 184045B	980259	Apr. 22,21	Apr. 21,22
3m Semi-anechoic Chamber	ETS-LINDGREN	9m*6m*6m	Euroshieldpn-CT0001143-1216	May. 19,20	May. 18,23
Test Software	E3	V 9.160323	N/A	N/A	N/A
Test Software	ADT	ADT_Radiated_V 7.6.15.9.2	N/A	N/A	N/A
10dB Attenuator	JFW/USA	50HF-010-SMA	1505	Jun. 03,21	Jun. 02,22
Power Meter	Anritsu	ML2495A	1506002	Apr. 07,21	Apr. 06,22
Power Sensor	Anritsu	MA2411B	1339352	May. 07,21	May. 06,22
Temperature Chamber	ESPEC	SH-242	93000855	Jun. 02,21	Jun. 01,22
MXG Analog Microwave Signal Generator	KEYSIGHT	N5183A	MY50143024	Mar. 05,21	Mar. 04,22
Power Divider	MCLI/USA	PS2-15	24880	N/A	N/A

- NOTE:**
1. The calibration interval of the above test instruments is 12 months or 36 months and the calibrations are traceable to CEPREI/CHINA, GRGT/CHINA and NIM/CHINA.
 2. The test was performed in 3m Semi-anechoic Chamber and RF Oven Room.
 3. The horn antenna is used only for the measurement of emission frequency above 1GHz if tested.
 4. The FCC Site Registration No. is 525120; The Designation No. is CN1171.

2 GENERAL INFORMATION

2.1 GENERAL DESCRIPTION OF EUT

PRODUCT	Pay Tablet	
BRAND NAME	PAX	
MODEL NAME	M8	
NOMINAL VOLTAGE	5Vdc /9Vdc /12Vdc (adapter) 3.85Vdc (Rechargeable Li-ion, battery)	
MODULATION TECHNOLOGY	WCDMA IV	HSDPA, HSUPA
	LTE	QPSK, 16QAM
FREQUENCY RANGE	WCDMA IV	1712.4MHz ~ 1752.6MHz
	LTE Band 4 Channel Bandwidth: 1.4MHz	1710.7MHz ~ 1754.3MHz
	LTE Band 4 Channel Bandwidth: 3MHz	1711.5MHz ~ 1753.5MHz
	LTE Band 4 Channel Bandwidth: 5MHz	1712.5MHz ~ 1752.5MHz
	LTE Band 4 Channel Bandwidth: 10MHz	1715MHz ~ 1750MHz
	LTE Band 4 Channel Bandwidth: 15MHz	1717.5MHz ~ 1747.5 MHz
	LTE Band 4 Channel Bandwidth: 20MHz	1720MHz ~ 1745MHz
	LTE Band 12 Channel Bandwidth: 1.4MHz	699.7MHz ~ 715.3MHz
	LTE Band 12 Channel Bandwidth: 3MHz	700.5MHz ~ 714.5MHz
	LTE Band 12 Channel Bandwidth: 5MHz	701.5MHz ~ 713.5MHz
	LTE Band 12 Channel Bandwidth: 10MHz	704MHz ~ 711MHz
	LTE Band 13 Channel Bandwidth: 5MHz	779.5MHz ~ 784.5MHz
	LTE Band 13 Channel Bandwidth: 10MHz	782MHz
	LTE Band 17 Channel Bandwidth: 5MHz	706.5MHz ~ 713.5MHz
	LTE Band 17 Channel Bandwidth: 10MHz	709MHz ~ 711 MHz

EMISSION DESIGNATOR	WCDMA IV	4M19F9W	
	LTE Band 4 Channel Bandwidth: 1.4MHz	QPSK: 1M13G7D 16QAM: 1M12W7D	
	LTE Band 4 Channel Bandwidth: 3MHz	QPSK: 2M73G7D 16QAM: 2M73W7D	
	LTE Band 4 Channel Bandwidth: 5MHz	QPSK: 4M55G7D 16QAM: 4M55W7D	
	LTE Band 4 Channel Bandwidth: 10MHz	QPSK: 9M07G7D 16QAM: 9M07W7D	
	LTE Band 4 Channel Bandwidth: 15MHz	QPSK: 13M6G7D 16QAM: 13M6W7D	
	LTE Band 4 Channel Bandwidth: 20MHz	QPSK: 18M1G7D 16QAM: 18M2W7D	
	LTE Band 12 Channel Bandwidth: 1.4MHz	QPSK: 1M13G7D 16QAM: 1M12W7D	
	LTE Band 12 Channel Bandwidth: 3MHz	QPSK: 2M73G7D 16QAM: 2M72W7D	
	LTE Band 12 Channel Bandwidth: 5MHz	QPSK: 4M58G7D 16QAM: 4M60W7D	
	LTE Band 12 Channel Bandwidth: 10MHz	QPSK: 9M11G7D 16QAM: 9M12W7D	
	LTE Band 13 Channel Bandwidth: 5MHz	QPSK: 4M58G7D 16QAM: 4M59W7D	
	LTE Band 13 Channel Bandwidth: 10MHz	QPSK: 9M08G7D 16QAM: 9M07W7D	
	LTE Band 17 Channel Bandwidth: 5MHz	QPSK: 4M60G7D 16QAM: 4M60W7D	
	LTE Band 17 Channel Bandwidth: 10MHz	QPSK: 9M08G7D 16QAM: 9M09W7D	
	MAX. EIRP POWER	WCDMA IV	115.61mW
		LTE Band 4 Channel Bandwidth: 1.4MHz	186.64mW
		LTE Band 4 Channel Bandwidth: 3MHz	185.78mW
		LTE Band 4 Channel Bandwidth: 5MHz	186.21mW
		LTE Band 4 Channel Bandwidth: 10MHz	186.21mW



BUREAU
VERITAS

Test Report No.: W7L-P21090022RF06

	LTE Band 4 Channel Bandwidth: 15MHz	186.64mW
	LTE Band 4 Channel Bandwidth: 20MHz	187.93mW
	LTE Band 12 Channel Bandwidth: 1.4MHz	139.96mW
	LTE Band 12 Channel Bandwidth: 3MHz	139.64mW
	LTE Band 12 Channel Bandwidth: 5MHz	139.64mW
	LTE Band 12 Channel Bandwidth: 10MHz	140.28mW
	LTE Band 13 Channel Bandwidth: 5MHz	104.47mW
	LTE Band 13 Channel Bandwidth: 10MHz	104.95mW
	LTE Band 17 Channel Bandwidth: 5MHz	139.32mW
	LTE Band 17 Channel Bandwidth: 10MHz	139.96mW
	ANTENNA TYPE	Fixed Internal Antenna with 1dBi gain for WCDMA B4/LTE B4 Fixed Internal Antenna with 0.5dBi gain for LTE B12/B13/B17
HW VERSION	M8-XXX-XXX-XXXX	
SW VERSION	V0.0.0.1	
I/O PORTS	Refer to user's manual	
CABLE SUPPLIED	USB cable: unshielded without ferrite, 1 meter	
EXTREME TEMPERATURE	-10-45 °C	
EXTREME VOLTAGE	3.7V- 4.25V	

NOTE:

- For a more detailed features description, please refer to the manufacturer's specifications or the user's manual.
- For the test results, the EUT had been tested with all conditions. But only the worst case was shown in test report.

3. List of Accessory:

ACCESSORIES	BRAND	MODEL	SPECIFICATION
Battery	IES	ICS021NA	Capacity : 3.85vdc 6300mAh
AC Adapter	/	GLH-PD18W-U	I/P:100-240Vac, 0.5A O/P: 5Vdc, 3A/9Vdc, 2A/12Vdc, 1.5A
USB Cable	/	HJ-20010506CC444	Shielded, 1meter

2.2 CONFIGURATION OF SYSTEM UNDER TEST

FOR RADIATION EMISSION TEST

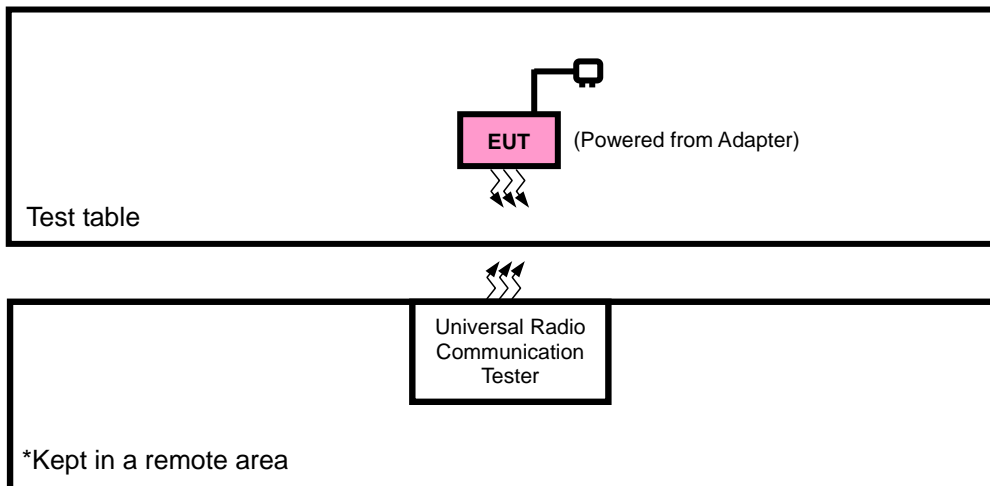

2.3 DESCRIPTION OF SUPPORT UNITS

The EUT has been tested as an independent unit together with other necessary accessories or support units. The following support units or accessories were used to form a representative test configuration during the tests.

NO.	PRODUCT	BRAND	MODEL NO.	SERIAL NO.	FCC ID
1	DC source	LONG WEI	PS-6403D	010934269	N/A

NO.	SIGNAL CABLE DESCRIPTION OF THE ABOVE SUPPORT UNITS
1	DC Line: Unshielded, Detachable 1.0m

2.4 TEST ITEM AND TEST CONFIGURATION

Pre-Scan has been conducted to determine the worst-case mode from all possible combinations between available modulations, data rates, XYZ axis and antenna ports. The worst case was found when positioned on Y-plane for EIRP and X-axis for radiated emission. Following channel(s) was (were) selected for the final test as listed below:

EUT CONFIGURE MODE	DESCRIPTION
A	EUT + Adapter + USB Cable with WCDMA link
B	EUT + Battery with WCDMA link

WCDMA MODE

EUT CONFIGURE MODE	TEST ITEM	AVAILABLE CHANNEL	TESTED CHANNEL	MODE
B	EIRP	1312 to 1513	1312, 1413, 1513	WCDMA
B	FREQUENCY STABILITY	1312 to 1513	1312, 1513	WCDMA
B	OCCUPIED BANDWIDTH	1312 to 1513	1312, 1413, 1513	WCDMA
B	BAND EDGE	1312 to 1513	1312, 1513	WCDMA
B	PEAK TO AVERAGE RATIO	1312 to 1513	1312, 1413, 1513	WCDMA
B	CONDCUDED EMISSION	1312 to 1513	1312, 1413, 1513	WCDMA
A	RADIATED EMISSION	1312 to 1513	1312, 1413, 1513	WCDMA

LTE BAND 4

EUT CONFIGURE MODE	TEST ITEM	AVAILABLE CHANNEL	TESTED CHANNEL	CHANNEL BANDWIDTH	MODULATION	MODE	
B	EIRP	19957 to 20393	19957, 20175, 20393	1.4MHz	QPSK, 16QAM	1 RB / 0 RB Offset	
		19965 to 20385	19965, 20175, 20385	3MHz	QPSK, 16QAM	1 RB / 0 RB Offset	
		19975 to 20375	19975, 20175, 20375	5MHz	QPSK, 16QAM	1 RB / 0 RB Offset	
		20000 to 20350	20000, 20175, 20350	10MHz	QPSK, 16QAM	1 RB / 0 RB Offset	
		20025 to 20325	20025, 20175, 20325	15MHz	QPSK, 16QAM	1 RB / 0 RB Offset	
		20050 to 20300	20050, 20175, 20300	20MHz	QPSK, 16QAM	1 RB / 0 RB Offset	
B	FREQUENCY STABILITY	19957 to 20393	19957, 20393	1.4MHz	QPSK	1 RB / 0 RB Offset	
		19965 to 20385	19965, 20385	3MHz	QPSK	1 RB / 0 RB Offset	
		19975 to 20375	19975, 20375	5MHz	QPSK	1 RB / 0 RB Offset	
		20000 to 20350	20000, 20350	10MHz	QPSK	1 RB / 0 RB Offset	
		20025 to 20325	20025, 20325	15MHz	QPSK	1 RB / 0 RB Offset	
		20050 to 20300	20050, 20300	20MHz	QPSK	1 RB / 0 RB Offset	
B	OCCUPIED BANDWIDTH	19957 to 20393	19957, 20175, 20393	1.4MHz	QPSK, 16QAM	6 RB / 0 RB Offset	
		19965 to 20385	19965, 20175, 20385	3MHz	QPSK, 16QAM	15 RB / 0 RB Offset	
		19975 to 20375	19975, 20175, 20375	5MHz	QPSK, 16QAM	25 RB / 0 RB Offset	
		20000 to 20350	20000, 20175, 20350	10MHz	QPSK, 16QAM	50 RB / 0 RB Offset	
		20025 to 20325	20025, 20175, 20325	15MHz	QPSK, 16QAM	75 RB / 0 RB Offset	
		20050 to 20300	20050, 20175, 20300	20MHz	QPSK, 16QAM	100 RB / 0 RB Offset	
B	PEAK TO AVERAGE RATIO	19957 to 20393	19957, 20175, 20393	1.4MHz	QPSK, 16QAM	1 RB / 0 RB Offset	
		19965 to 20385	19965, 20175, 20385	3MHz	QPSK, 16QAM	1 RB / 0 RB Offset	
		19975 to 20375	19975, 20175, 20375	5MHz	QPSK, 16QAM	1 RB / 0 RB Offset	
		20000 to 20350	20000, 20175, 20350	10MHz	QPSK, 16QAM	1 RB / 0 RB Offset	
		20025 to 20325	20025, 20175, 20325	15MHz	QPSK, 16QAM	1 RB / 0 RB Offset	
		20050 to 20300	20050, 20175, 20300	20MHz	QPSK, 16QAM	1 RB / 0 RB Offset	
B	BAND EDGE	19957 to 20393	19957	1.4MHz	QPSK, 16QAM	1 RB / 0 RB Offset	
			20393	1.4MHz	QPSK, 16QAM	6 RB / 0 RB Offset	
		19965 to 20385	19965	3MHz	QPSK, 16QAM	1 RB / 0 RB Offset	
			20385	3MHz	QPSK, 16QAM	15 RB / 0 RB Offset	
		19975 to 20375	19975	5MHz	QPSK, 16QAM	1 RB / 0 RB Offset	
			20375	5MHz	QPSK, 16QAM	25 RB / 0 RB Offset	
		20000 to 20350	20000	10MHz	QPSK, 16QAM	1 RB / 0 RB Offset	
			20350	10MHz	QPSK, 16QAM	50 RB / 0 RB Offset	
							1 RB / 5 RB Offset
							6 RB / 0 RB Offset
							15 RB / 0 RB Offset
							1 RB / 14 RB Offset
					25 RB / 0 RB Offset		
					1 RB / 24 RB Offset		
					25 RB / 0 RB Offset		

B	BAND EDGE	20025 to 20325	20025	15MHz	QPSK, 16QAM	1 RB / 0 RB Offset
			20325	15MHz	QPSK, 16QAM	75 RB / 0 RB Offset
		20050 to 20300	20050	20MHz	QPSK, 16QAM	1 RB / 74 RB Offset
			20300	20MHz	QPSK, 16QAM	75 RB / 0 RB Offset
						1 RB / 0 RB Offset
						100 RB / 0 RB Offset
B	CONDCUDETED EMISSION	19957 to 20393	19957, 20175, 20393	1.4MHz	QPSK	1 RB / 0 RB Offset
		19965 to 20385	19965, 20175, 20385	3MHz	QPSK	1 RB / 0 RB Offset
		19975 to 20375	19975, 20175, 20375	5MHz	QPSK	1 RB / 0 RB Offset
		20000 to 20350	20000, 20175, 20350	10MHz	QPSK	1 RB / 0 RB Offset
		20025 to 20325	20025, 20175, 20325	15MHz	QPSK	1 RB / 0 RB Offset
		20050 to 20300	20050, 20175, 20300	20MHz	QPSK	1 RB / 0 RB Offset
A	RADIATED EMISSION	19957 to 20393	19957, 20175, 20393	1.4MHz	QPSK	1 RB / 0 RB Offset
		19965 to 20385	20175	3MHz	QPSK	1 RB / 0 RB Offset
		19975 to 20375	20175	5MHz	QPSK	1 RB / 0 RB Offset
		20000 to 20350	20175	10MHz	QPSK	1 RB / 0 RB Offset
		20025 to 20325	20175	15MHz	QPSK	1 RB / 0 RB Offset
		20050 to 20300	20175	20MHz	QPSK	1 RB / 0 RB Offset

Note: This device was tested under all bandwidths, RB configurations and modulations. The worst case was found in QPSK modulation.

LTE BAND 12

EUT CONFIGURE MODE	TEST ITEM	AVAILABLE CHANNEL	TESTED CHANNEL	CHANNEL BANDWIDTH	MODULATION	MODE		
B	ERP	23017 to 23173	23017, 23095 , 23173	1.4MHz	QPSK, 16QAM	1 RB / 0 RB Offset		
		23025 to 23165	23025, 23095 ,23165	3MHz	QPSK, 16QAM	1 RB / 0 RB Offset		
		23035 to 23155	23035, 23095 ,23155	5MHz	QPSK, 16QAM	1 RB / 0 RB Offset		
		23060 to 23130	23060, 23095 ,23130	10MHz	QPSK, 16QAM	1 RB / 0 RB Offset		
B	FREQUENCY STABILITY	23017 to 23173	23017, 23173	1.4MHz	QPSK	1 RB / 0 RB Offset		
		23025 to 23165	23025, 23165	3MHz	QPSK	1 RB / 0 RB Offset		
		23035 to 23155	23035, 23155	5MHz	QPSK	1 RB / 0 RB Offset		
		23060 to 23130	23060, 23130	10MHz	QPSK	1 RB / 0 RB Offset		
B	OCCUPIED BANDWIDTH	23017 to 23173	23017, 23095 , 23173	1.4MHz	QPSK, 16QAM	6 RB / 0 RB Offset		
		23025 to 23165	23025, 23095 ,23165	3MHz	QPSK, 16QAM	15 RB / 0 RB Offset		
		23035 to 23155	23035, 23095 ,23155	5MHz	QPSK, 16QAM	25 RB / 0 RB Offset		
		23060 to 23130	23060, 23095 ,23130	10MHz	QPSK, 16QAM	50 RB / 0 RB Offset		
B	PEAK TO AVERAGE RATIO	23017 to 23173	23017, 23095 , 23173	1.4MHz	QPSK, 16QAM	1 RB / 0 RB Offset		
		23025 to 23165	23025, 23095 ,23165	3MHz	QPSK, 16QAM	1 RB / 0 RB Offset		
		23035 to 23155	23035, 23095 ,23155	5MHz	QPSK, 16QAM	1 RB / 0 RB Offset		
		23060 to 23130	23060, 23095 ,23130	10MHz	QPSK, 16QAM	1 RB / 0 RB Offset		
B	BAND EDGE	23017 to 23173	23017	1.4MHz	QPSK	1 RB / 0 RB Offset 6 RB / 0 RB Offset		
			23173	1.4MHz	QPSK	1 RB / 5 RB Offset 6 RB / 0 RB Offset		
		23025 to 23165	23025	3MHz	QPSK	1 RB / 0 RB Offset 15 RB / 0 RB Offset		
			23165	3MHz	QPSK	1 RB / 14 RB Offset 15 RB / 0 RB Offset		
		23035 to 23155	23035	5MHz	QPSK	1 RB / 0 RB Offset 25 RB / 0 RB Offset		
			23155	5MHz	QPSK	1 RB / 24 RB Offset 25 RB / 0 RB Offset		
		23060 to 23130	23060	10MHz	QPSK	1 RB / 0 RB Offset 50 RB / 0 RB Offset		
			23130	10MHz	QPSK	1 RB / 49 RB Offset 50 RB / 0 RB Offset		
		B	CONDCUETED EMISSION	23017 to 23173	23017, 23095 , 23173	1.4MHz	QPSK	1 RB / 0 RB Offset
				23025 to 23165	23025, 23095 ,23165	3MHz	QPSK	1 RB / 0 RB Offset
				23035 to 23155	23035, 23095 ,23155	5MHz	QPSK	1 RB / 0 RB Offset
				23060 to 23130	23060, 23095 ,23130	10MHz	QPSK	1 RB / 0 RB Offset
A	RADIATED EMISSION	23017 to 23173	23017, 23095 , 23173	1.4MHz	QPSK	1 RB / 0 RB Offset		
		23025 to 23165	23095	3MHz	QPSK	1 RB / 0 RB Offset		
		23035 to 23155	23095	5MHz	QPSK	1 RB / 0 RB Offset		
		23060 to 23130	23095	10MHz	QPSK	1 RB / 0 RB Offset		

Note: This device was tested under all bandwidths, RB configurations and modulations. The worst case was found in QPSK modulation.

LTE BAND 13

EUT CONFIGURE MODE	TEST ITEM	AVAILABLE CHANNEL	TESTED CHANNEL	CHANNEL BANDWIDTH	MODULATION	MODE
B	ERP	23205 to 23255	20025, 20175, 20325	5MHz	QPSK, 16QAM	1 RB / 0 RB Offset
		23230	23230	10MHz	QPSK, 16QAM	1 RB / 0 RB Offset
B	FREQUENCY STABILITY	23205 to 23255	20025, 20325	1.4MHz	QPSK	1 RB / 0 RB Offset
		23230	23230	10MHz	QPSK	1 RB / 0 RB Offset
B	OCCUPIED BANDWIDTH	23205 to 23255	20025, 20175, 20325	5MHz	QPSK, 16QAM	25 RB / 0 RB Offset
		23230	23230	10MHz	QPSK, 16QAM	50 RB / 0 RB Offset
B	BAND EDGE	23205 to 23255	23250	5MHz	QPSK, 16QAM	1 RB / 0 RB Offset
			23255	5MHz	QPSK, 16QAM	25 RB / 0 RB Offset
		23230	23230	10MHz	QPSK, 16QAM	1 RB / 24 RB Offset
			/	10MHz	QPSK, 16QAM	25 RB / 0 RB Offset
			/	10MHz	QPSK, 16QAM	1 RB / 0 RB Offset
			/	10MHz	QPSK, 16QAM	50 RB / 0 RB Offset
B	CONDCUDED EMISSION	23205 to 23255	20025, 20175, 20325	5MHz	QPSK	1 RB / 0 RB Offset
		23230	23230	10MHz	QPSK	1 RB / 0 RB Offset
A	RADIATED EMISSION	23205 to 23255	20025, 20175, 20325	5MHz	QPSK	1 RB / 0 RB Offset
		23230	23230	10MHz	QPSK	1 RB / 0 RB Offset

Note: This device was tested under all bandwidths, RB configurations and modulations. The worst case was found in QPSK modulation.



Test Report No.: W7L-P21090022RF06

LTE BAND 17

EUT CONFIGURE MODE	TEST ITEM	AVAILABLE CHANNEL	TESTED CHANNEL	CHANNEL BANDWIDTH	MODULATION	MODE
B	ERP	23755 to 23825	23755, 23790, 23825	5MHz	QPSK, 16QAM	1 RB / 0 RB Offset
		23780 to 23800	23780, 23790, 23800	10MHz	QPSK, 16QAM	1 RB / 0 RB Offset
B	FREQUENCY STABILITY	23755 to 23825	23755, 23825	5MHz	QPSK	1 RB / 0 RB Offset
		23780 to 23800	23780, 23800	10MHz	QPSK	1 RB / 0 RB Offset
B	OCCUPIED BANDWIDTH	23755 to 23825	23755, 23790, 23825	5MHz	QPSK, 16QAM	25 RB / 0 RB Offset
		23780 to 23800	23780, 23790, 23800	10MHz	QPSK, 16QAM	50 RB / 0 RB Offset
B	BAND EDGE	23755 to 23825	23755	5MHz	QPSK, 16QAM	1 RB / 0 RB Offset
			23825	5MHz	QPSK, 16QAM	25 RB / 0 RB Offset
		23780 to 23800	23780	10MHz	QPSK, 16QAM	1 RB / 0 RB Offset
			23800	10MHz	QPSK, 16QAM	50 RB / 0 RB Offset
			23780	10MHz	QPSK, 16QAM	1 RB / 49 RB Offset
			23800	10MHz	QPSK, 16QAM	50 RB / 0 RB Offset
B	CONDCUDETED EMISSION	23755 to 23825	23755, 23790, 23825	5MHz	QPSK	1 RB / 0 RB Offset
		23780 to 23800	23780, 23790, 23800	10MHz	QPSK	1 RB / 0 RB Offset
A	RADIATED EMISSION	23755 to 23825	23790	5MHz	QPSK	1 RB / 0 RB Offset
		23780 to 23800	23780, 23790, 23800	10MHz	QPSK	1 RB / 0 RB Offset

Note: This device was tested under all bandwidths, RB configurations and modulations. The worst case was found in QPSK modulation.



Test Report No.: W7L-P21090022RF06

TEST CONDITION:

TEST ITEM	ENVIRONMENTAL CONDITIONS	INPUT POWER	TESTED BY
ERP/EIRP	23deg. C, 70%RH	DC 3.85V	Jace Hu
FREQUENCY STABILITY	23deg. C, 70%RH	DC 3.85V	James Fu
OCCUPIED BANDWIDTH	23deg. C, 70%RH	DC 3.85V	James Fu
BAND EDGE	23deg. C, 70%RH	DC 3.85V	James Fu
CONDCUDED EMISSION	23deg. C, 70%RH	DC 3.85V	James Fu
RADIATED EMISSION	23deg. C, 70%RH	DC 3.85V	Jace Hu



Test Report No.: W7L-P21090022RF06

2.5 GENERAL DESCRIPTION OF APPLIED STANDARDS

The EUT is a RF product. According to the specifications of the manufacturer, it must comply with the requirements of the following standards:

FCC 47 CFR Part 2

FCC 47 CFR Part 27

KDB 971168 D01 Power Meas License Digital Systems v03r01

ANSI/TIA/EIA-603-D

ANSI/TIA/EIA-603-E

ANSI C63.26-2015

NOTE: All test items have been performed and recorded as per the above standards.



3 TEST TYPES AND RESULTS

3.1 OUTPUT POWER MEASUREMENT

3.1.1 LIMITS OF OUTPUT POWER MEASUREMENT

The radiated peak output power shall be according to the specific rule Part 27.50(h)(2) that “User stations are limited to 2 watts” and 27.50(i) specific that “Peak transmit power must be measure over any interval of continuous transmission using instrumentation calibration in terms of rms-equivalent voltage.”

Fixed, mobile, and portable (hand-held) stations operating in the 1710-1755 MHz band and mobile and portable stations operating in the 1695-1710 MHz and 1755-1780 MHz bands are limited to 1 watt EIRP

3.1.2 TEST PROCEDURES

EIRP MEASUREMENT:

Per KDB 971168 D01 Power Meas License Digital Systems v03r01 or subclause 5.2.5.5 of ANSI C63.26-2015, the relevant equation for determining the ERP or EIRP from the conducted RF output power measured using the guidance provided above is:

$$\text{ERP or EIRP} = P_{\text{Meas}} + G_{\text{T}} - L_{\text{C}}$$

Where:

ERP or EIRP = effective radiated power or equivalent isotropically radiated power, respectively

(expressed in the same units as P_{Meas} , typically dBW or dBm);

P_{Meas} = measured transmitter output power or PSD, in dBm or dBW;

G_{T} = gain of the transmitting antenna, in dBd (ERP) or dBi (EIRP);

L_{C} = signal attenuation in the connecting cable between the transmitter and antenna, in dB.

CONDUCTED POWER MEASUREMENT:

- a. The EUT was set up for the maximum power with LTE link data modulation and link up with simulator.
- b. Set the EUT to transmit under low, middle and high channel and record the power level shown on simulator.

3.1.3 TEST SETUP

CONDUCTED POWER MEASUREMENT:

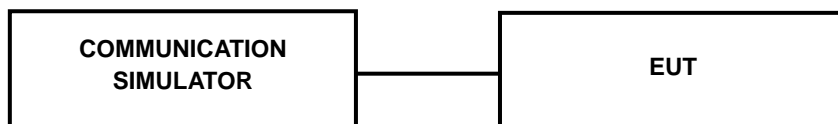

For the actual test configuration, please refer to the attached file (Test Setup Photo).

3.1.4 TEST RESULTS

AVERAGE CONDUCTED OUTPUT POWER (dBm)

Band	WCDMA IV			Max. Tune-up Power
	1312	1413	1513	
Channel	1712.4	1732.6	1752.6	
Frequency (MHz)	1712.4	1732.6	1752.6	
RMC 12.2K	21.78	21.75	21.72	22.5
HSDPA Subtest-1	20.75	20.68	20.66	21.5
HSDPA Subtest-2	20.73	20.65	20.64	21.5
HSDPA Subtest-3	20.21	20.19	20.18	21.0
HSDPA Subtest-4	20.19	20.16	20.15	21.0
HSUPA Subtest-1	20.70	20.69	20.65	21.5
HSUPA Subtest-2	18.67	18.65	18.63	19.5
HSUPA Subtest-3	19.67	19.66	19.65	20.5
HSUPA Subtest-4	18.64	18.63	18.65	19.5
HSUPA Subtest-5	20.68	20.66	20.67	21.5

LTE Band 4

Band/BW	Modulation	RB Size	RB Offset	Low CH 19957	Mid CH 20175	High CH 20393	MPR
				Frequency 1710.7 MHz	Frequency 1732.5 MHz	Frequency 1754.3 MHz	
4/ 1.4	QPSK	1	0	21.39	21.41	21.34	0
		1	2	21.69	21.68	21.67	0
		1	5	21.35	21.32	21.29	0
		3	0	21.62	21.62	21.70	0
		3	1	21.71	21.70	21.59	0
		3	3	21.63	21.62	21.67	0
		6	0	20.72	20.65	20.68	1
	16QAM	1	0	20.79	20.80	20.75	1
		1	2	21.06	21.00	21.07	1
		1	5	20.58	20.60	20.64	1
		3	0	20.77	20.71	20.76	1
		3	1	20.65	20.77	20.70	1
		3	3	20.73	20.70	20.76	1
		6	0	19.72	19.73	19.65	2

Band/BW	Modulation	RB Size	RB Offset	Low CH 19965	Mid CH 20175	High CH 20385	MPR
				Frequency 1711.5 MHz	Frequency 1732.5 MHz	Frequency 1753.5 MHz	
4/ 3	QPSK	1	0	21.41	21.43	21.33	0
		1	7	21.65	21.69	21.67	0
		1	14	21.31	21.32	21.29	0
		8	0	20.61	20.65	20.70	1
		8	3	20.64	20.70	20.61	1
		8	7	20.60	20.69	20.71	1
		15	0	20.69	20.66	20.62	1
	16QAM	1	0	20.76	20.86	20.78	1
		1	7	21.03	21.03	21.05	1
		1	14	20.61	20.60	20.64	1
		8	0	19.73	19.72	19.76	2
		8	3	19.70	19.72	19.73	2
		8	7	19.75	19.68	19.72	2
		15	0	19.72	19.67	19.68	2



**BUREAU
VERITAS**

Test Report No.: W7L-P21090022RF06

Band/BW	Modulation	RB Size	RB Offset	Low CH 19975	Mid CH 20175	High CH 20375	MPR
				Frequency 1712.5 MHz	Frequency 1732.5 MHz	Frequency 1752.5 MHz	
4/ 5	QPSK	1	0	21.42	21.38	21.34	0
		1	12	21.70	21.66	21.67	0
		1	24	21.32	21.31	21.33	0
		12	0	20.64	20.65	20.67	1
		12	6	20.64	20.71	20.62	1
		12	13	20.64	20.65	20.72	1
		25	0	20.67	20.69	20.65	1
	16QAM	1	0	20.77	20.82	20.78	1
		1	12	21.00	21.06	21.04	1
		1	24	20.61	20.60	20.63	1
		12	0	19.73	19.70	19.73	2
		12	6	19.67	19.76	19.69	2
		12	13	19.70	19.70	19.75	2
		25	0	19.72	19.68	19.65	2

Band/BW	Modulation	RB Size	RB Offset	Low CH 20000	Mid CH 20175	High CH 20350	MPR
				Frequency 1715 MHz	Frequency 1732.5 MHz	Frequency 1750 MHz	
4/ 10	QPSK	1	0	21.39	21.41	21.34	0
		1	24	21.70	21.66	21.68	0
		1	49	21.29	21.35	21.29	0
		25	0	20.65	20.64	20.70	1
		25	12	20.70	20.65	20.62	1
		25	25	20.62	20.62	20.71	1
		50	0	20.72	20.69	20.62	1
	16QAM	1	0	20.77	20.79	20.74	1
		1	24	21.05	21.02	21.07	1
		1	49	20.61	20.61	20.60	1
		25	0	19.75	19.68	19.79	2
		25	12	19.71	19.70	19.74	2
		25	25	19.69	19.71	19.72	2
		50	0	19.76	19.67	19.69	2

Band/BW	Modulation	RB Size	RB Offset	Low CH 20025	Mid CH 20175	High CH 20325	MPR
				Frequency 1717.5 MHz	Frequency 1732.5 MHz	Frequency 1747.5 MHz	
4/ 15	QPSK	1	0	21.46	21.41	21.31	0
		1	37	21.68	21.71	21.63	0
		1	74	21.35	21.38	21.30	0
		36	0	20.62	20.65	20.71	1
		36	19	20.71	20.70	20.62	1
		36	39	20.60	20.63	20.71	1
		75	0	20.72	20.67	20.67	1
	16QAM	1	0	20.81	20.86	20.74	1
		1	37	21.04	21.03	21.07	1
		1	74	20.57	20.66	20.62	1
		36	0	19.79	19.68	19.80	2
		36	19	19.65	19.74	19.70	2
		36	39	19.74	19.69	19.75	2
		75	0	19.77	19.70	19.62	2

Band/BW	Modulation	RB Size	RB Offset	Low CH 20050	Mid CH 20175	High CH 20300	MPR
				Frequency 1720 MHz	Frequency 1732.5 MHz	Frequency 1745 MHz	
4/ 20	QPSK	1	0	21.47	21.45	21.39	0
		1	50	21.72	21.74	21.69	0
		1	99	21.37	21.39	21.34	0
		50	0	20.68	20.70	20.72	1
		50	25	20.72	20.75	20.67	1
		50	50	20.68	20.70	20.73	1
		100	0	20.73	20.74	20.70	1
	16QAM	1	0	20.84	20.87	20.80	1
		1	50	21.08	21.08	21.09	1
		1	99	20.63	20.68	20.65	1
		50	0	19.81	19.76	19.81	2
		50	25	19.73	19.78	19.75	2
		50	50	19.77	19.75	19.77	2
		100	0	19.78	19.75	19.70	2



**BUREAU
VERITAS**

Test Report No.: W7L-P21090022RF06

LTE Band 12

Band/BW	Modulation	RB Size	RB Offset	Low CH 23017	Mid CH 23095	High CH 23173	MPR
				Frequency 699.7 MHz	Frequency 707.5 MHz	Frequency 715.3 MHz	
12/ 1.4	QPSK	1	0	22.83	22.89	22.87	0
		1	2	23.06	23.01	23.10	0
		1	5	22.98	22.94	23.00	0
		3	0	22.99	23.00	23.03	0
		3	1	22.97	23.07	22.94	0
		3	3	23.08	23.08	23.11	0
		6	0	22.05	22.02	22.12	1
	16QAM	1	0	22.10	22.14	22.16	1
		1	2	22.31	22.35	22.35	1
		1	5	22.20	22.15	22.25	1
		3	0	21.99	22.04	21.99	1
		3	1	21.99	22.14	22.03	1
		3	3	22.12	22.17	22.21	1
		6	0	21.04	21.11	21.07	2

Band/BW	Modulation	RB Size	RB Offset	Low CH 23025	Mid CH 23095	High CH 23165	MPR
				Frequency 700.5 MHz	Frequency 707.5 MHz	Frequency 714.5 MHz	
12/ 3	QPSK	1	0	22.85	22.91	22.86	0
		1	7	23.02	23.02	23.10	0
		1	14	22.94	22.94	23.00	0
		8	0	21.98	22.03	22.03	1
		8	3	21.90	22.07	21.96	1
		8	7	22.05	22.15	22.15	1
		15	0	22.02	22.03	22.06	1
	16QAM	1	0	22.07	22.20	22.19	1
		1	7	22.28	22.38	22.33	1
		1	14	22.23	22.15	22.25	1
		8	0	20.95	21.05	20.99	2
		8	3	21.04	21.09	21.06	2
		8	7	21.14	21.15	21.17	2
		15	0	21.04	21.05	21.10	2

Band/BW	Modulation	RB Size	RB Offset	Low CH 23035	Mid CH 23095	High CH 23155	MPR
				Frequency 701.5 MHz	Frequency 707.5 MHz	Frequency 713.5 MHz	
12/ 5	QPSK	1	0	22.86	22.86	22.87	0
		1	12	23.07	22.99	23.10	0
		1	24	22.95	22.93	23.04	0
		12	0	22.01	22.03	22.00	1
		12	6	21.90	22.08	21.97	1
		12	13	22.09	22.11	22.16	1
		25	0	22.00	22.06	22.09	1
	16QAM	1	0	22.08	22.16	22.19	1
		1	12	22.25	22.41	22.32	1
		1	24	22.23	22.15	22.24	1
		12	0	20.95	21.03	20.96	2
		12	6	21.01	21.13	21.02	2
		12	13	21.09	21.17	21.20	2
		25	0	21.04	21.06	21.07	2

Band/BW	Modulation	RB Size	RB Offset	Low CH 23060	Mid CH 23095	High CH 23130	MPR
				Frequency 704 MHz	Frequency 707.5 MHz	Frequency 711 MHz	
12/ 10	QPSK	1	0	22.91	22.93	22.92	0
		1	24	23.09	23.07	23.12	0
		1	49	23.00	23.01	23.05	0
		25	0	22.05	22.08	22.05	1
		25	12	21.98	22.09	22.02	1
		25	25	22.13	22.16	22.17	1
		50	0	22.06	22.08	22.14	1
	16QAM	1	0	22.15	22.21	22.21	1
		1	24	22.33	22.43	22.37	1
		1	49	22.25	22.23	22.26	1
		25	0	21.03	21.09	21.04	2
		25	12	21.07	21.15	21.08	2
		25	25	21.16	21.22	21.22	2
		50	0	21.10	21.13	21.12	2



**BUREAU
VERITAS**

Test Report No.: W7L-P21090022RF06

LTE Band 13

Band/BW	Modulation	RB Size	RB Offset	Low CH 23205	Mid CH 23230	High CH 23255	MPR
				Frequency 779.5 MHz	Frequency 782.0 MHz	Frequency 784.5 MHz	
13/ 5	QPSK	1	0	21.75	21.73	21.75	0
		1	12	21.84	21.78	21.84	0
		1	24	21.75	21.72	21.79	0
		12	0	20.73	20.72	20.72	1
		12	6	20.74	20.81	20.77	1
		12	13	20.75	20.74	20.78	1
		25	0	20.71	20.75	20.72	1
	16QAM	1	0	21.01	21.03	21.06	1
		1	12	21.05	21.11	21.08	1
		1	24	21.06	21.00	21.06	1
		12	0	19.74	19.76	19.74	2
		12	6	19.81	19.85	19.81	2
		12	13	19.78	19.80	19.83	2
		25	0	19.78	19.77	19.79	2

Band/BW	Modulation	RB Size	RB Offset	/	Mid CH 23230	/	MPR
				/	Frequency 782.0 MHz	/	
13/ 10	QPSK	1	0	/	21.80	/	0
		1	24	/	21.86	/	0
		1	49	/	21.80	/	0
		25	0	/	20.77	/	1
		25	12	/	20.82	/	1
		25	25	/	20.79	/	1
		50	0	/	20.77	/	1
	16QAM	1	0	/	21.08	/	1
		1	24	/	21.13	/	1
		1	49	/	21.08	/	1
		25	0	/	19.82	/	2
		25	12	/	19.87	/	2
		25	25	/	19.85	/	2
		50	0	/	19.84	/	2

LTE Band 17

Band/BW	Modulation	RB Size	RB Offset	Low CH 23755	Mid CH 23790	High CH 23825	MPR
				Frequency 706.5 MHz	Frequency 710 MHz	Frequency 713.5 MHz	
17/ 5	QPSK	1	0	22.88	22.86	22.87	0
		1	12	23.09	22.99	23.08	0
		1	24	22.96	22.92	23.03	0
		12	0	21.94	21.94	21.91	1
		12	6	21.96	22.12	22.01	1
		12	13	22.03	22.03	22.08	1
		25	0	21.94	22.04	21.95	1
	16QAM	1	0	22.13	22.19	22.22	1
		1	12	22.24	22.38	22.29	1
		1	24	22.28	22.18	22.27	1
		12	0	20.90	20.96	20.89	2
		12	6	21.04	21.14	21.03	2
		12	13	21.01	21.07	21.10	2
		25	0	21.00	21.00	21.01	2

Band/BW	Modulation	RB Size	RB Offset	Low CH 23780	Mid CH 23790	High CH 23800	MPR
				Frequency 709 MHz	Frequency 710 MHz	Frequency 711 MHz	
17/ 10	QPSK	1	0	22.93	22.93	22.92	0
		1	24	23.11	23.07	23.10	0
		1	49	23.01	23.00	23.04	0
		25	0	21.98	21.99	21.96	1
		25	12	22.04	22.13	22.06	1
		25	25	22.07	22.08	22.09	1
		50	0	22.00	22.06	22.00	1
	16QAM	1	0	22.20	22.24	22.24	1
		1	24	22.32	22.40	22.34	1
		1	49	22.30	22.26	22.29	1
		25	0	20.98	21.02	20.97	2
		25	12	21.10	21.16	21.09	2
		25	25	21.08	21.12	21.12	2
		50	0	21.06	21.07	21.06	2

EIRP

WCDMA IV

Channel	Frequency (MHz)	Conducted Power (dBm)	G _T -L _c (dB)	EIRP (dBm)	EIRP (mW)	Limit (W)
1312	1712.4	21.78	1	20.63	115.61	1
1413	1732.6	21.75	1	20.6	114.82	1
1513	1752.6	21.72	1	20.57	114.02	1

LTE BAND 4

CHANNEL BANDWIDTH: 1.4MHz QPSK

Channel	Frequency (MHz)	Conducted Power (dBm)	G _T -L _c (dB)	EIRP (dBm)	EIRP (mW)	Limit (W)
19957	1710.7	21.71	1	22.71	186.64	1
20175	1732.5	21.7	1	22.7	186.21	1
20393	1754.3	21.7	1	22.7	186.21	1

CHANNEL BANDWIDTH: 1.4MHz 16QAM

Channel	Frequency (MHz)	Conducted Power (dBm)	G _T -L _c (dB)	EIRP (dBm)	EIRP (mW)	Limit (W)
19957	1710.7	21.06	1	22.06	160.69	1
20175	1732.5	21	1	22	158.49	1
20393	1754.3	21.07	1	22.07	161.06	1

CHANNEL BANDWIDTH: 3MHz QPSK

Channel	Frequency (MHz)	Conducted Power (dBm)	G _T -L _c (dB)	EIRP (dBm)	EIRP (mW)	Limit (W)
19965	1711.5	21.65	1	22.65	184.08	1
20175	1732.5	21.69	1	22.69	185.78	1
20385	1753.5	21.67	1	22.67	184.93	1

CHANNEL BANDWIDTH: 3MHz 16QAM

Channel	Frequency (MHz)	Conducted Power (dBm)	G _T -L _c (dB)	EIRP (dBm)	EIRP (mW)	Limit (W)
19965	1711.5	21.03	1	22.03	159.59	1
20175	1732.5	21.03	1	22.03	159.59	1
20385	1753.5	19.68	1	20.68	116.95	1

CHANNEL BANDWIDTH: 5MHz QPSK

Channel	Frequency (MHz)	Conducted Power (dBm)	G _T -L _c (dB)	EIRP (dBm)	EIRP (mW)	Limit (W)
19975	1712.5	21.7	1	22.7	186.21	1
20175	1732.5	21.66	1	22.66	184.5	1
20375	1752.5	21.67	1	22.67	184.93	1

CHANNEL BANDWIDTH: 5MHz 16QAM

Channel	Frequency (MHz)	Conducted Power (dBm)	G _T -L _c (dB)	EIRP (dBm)	EIRP (mW)	Limit (W)
19975	1712.5	21	1	22	158.49	1
20175	1732.5	21.06	1	22.06	160.69	1
20375	1752.5	21.04	1	22.04	159.96	1

CHANNEL BANDWIDTH: 10MHz QPSK

Channel	Frequency (MHz)	Conducted Power (dBm)	G _T -L _c (dB)	EIRP (dBm)	EIRP (mW)	Limit (W)
20000	1715	21.7	1	22.7	186.21	1
20175	1732.5	21.66	1	22.66	184.5	1
20350	1750	21.68	1	22.68	185.35	1

CHANNEL BANDWIDTH: 10MHz 16QAM

Channel	Frequency (MHz)	Conducted Power (dBm)	G _T -L _c (dB)	EIRP (dBm)	EIRP (mW)	Limit (W)
20000	1715	21.05	1	22.05	160.32	1
20175	1732.5	21.02	1	22.02	159.22	1
20350	1750	21.07	1	22.07	161.06	1

CHANNEL BANDWIDTH: 15MHz QPSK

Channel	Frequency (MHz)	Conducted Power (dBm)	G _T -L _c (dB)	EIRP (dBm)	EIRP (mW)	Limit (W)
20025	1717.5	21.68	1	22.68	185.35	1
20175	1732.5	21.71	1	22.71	186.64	1
20325	1747.5	21.63	1	22.63	183.23	1

CHANNEL BANDWIDTH: 15MHz 16QAM

Channel	Frequency (MHz)	Conducted Power (dBm)	G _T -L _c (dB)	EIRP (dBm)	EIRP (mW)	Limit (W)
20025	1717.5	21.04	1	22.04	159.96	1
20175	1732.5	21.03	1	22.03	159.59	1
20325	1747.5	21.07	1	22.07	161.06	1

CHANNEL BANDWIDTH: 20MHz QPSK

Channel	Frequency (MHz)	Conducted Power (dBm)	G _T -L _c (dB)	EIRP (dBm)	EIRP (mW)	Limit (W)
20050	1720	21.72	1	22.72	187.07	1
20175	1732.5	21.74	1	22.74	187.93	1
20300	1745	21.69	1	22.69	185.78	1

CHANNEL BANDWIDTH: 20MHz 16QAM

Channel	Frequency (MHz)	Conducted Power (dBm)	G _T -L _c (dB)	EIRP (dBm)	EIRP (mW)	Limit (W)
20050	1720	21.08	1	22.08	161.44	1
20175	1732.5	21.08	1	22.08	161.44	1
20300	1745	21.09	1	22.09	161.81	1

REMARKS: ERP Output Power (dBm) = EIRP (dBm) -2.15(dB).

LTE BAND 12

CHANNEL BANDWIDTH: 1.4MHz QPSK

Channel	Frequency (MHz)	Conducted Power (dBm)	G _T -L _c (dB)	ERP (dBm)	ERP (mW)	Limit (W)
23017	699.7	23.08	0.5	21.43	139	3
23095	707.5	23.08	0.5	21.43	139	3
23173	715.3	23.11	0.5	21.46	139.96	3

CHANNEL BANDWIDTH: 1.4MHz 16QAM

Channel	Frequency (MHz)	Conducted Power (dBm)	G _T -L _c (dB)	ERP (dBm)	ERP (mW)	Limit (W)
23017	699.7	22.31	0.5	20.66	116.41	3
23095	707.5	22.35	0.5	20.7	117.49	3
23173	715.3	22.35	0.5	20.7	117.49	3

CHANNEL BANDWIDTH: 3MHz QPSK

Channel	Frequency (MHz)	Conducted Power (dBm)	G _T -L _c (dB)	ERP (dBm)	ERP (mW)	Limit (W)
23025	700.5	23.02	0.5	21.37	137.09	3
23095	707.5	23.02	0.5	21.37	137.09	3
23165	714.5	23.1	0.5	21.45	139.64	3

CHANNEL BANDWIDTH: 3MHz 16QAM

Channel	Frequency (MHz)	Conducted Power (dBm)	G _T -L _c (dB)	ERP (dBm)	ERP (mW)	Limit (W)
23025	700.5	22.28	0.5	20.63	115.61	3
23095	707.5	22.38	0.5	20.73	118.3	3
23165	714.5	22.33	0.5	20.68	116.95	3

CHANNEL BANDWIDTH: 5MHz QPSK

Channel	Frequency (MHz)	Conducted Power (dBm)	G _T -L _c (dB)	ERP (dBm)	ERP (mW)	Limit (W)
23035	701.5	23.07	0.5	21.42	138.68	3
23095	707.5	22.99	0.5	21.34	136.14	3
23155	713.5	23.1	0.5	21.45	139.64	3

CHANNEL BANDWIDTH: 5MHz 16QAM

Channel	Frequency (MHz)	Conducted Power (dBm)	G _T -L _c (dB)	ERP (dBm)	ERP (mW)	Limit (W)
23035	701.5	22.25	0.5	20.6	114.82	3
23095	707.5	22.41	0.5	20.76	119.12	3
23155	713.5	22.32	0.5	20.67	116.68	3

CHANNEL BANDWIDTH: 10MHz QPSK

Channel	Frequency (MHz)	Conducted Power (dBm)	G _T -L _c (dB)	ERP (dBm)	ERP (mW)	Limit (W)
23060	704	23.09	0.5	21.44	139.32	3
23095	707.5	23.07	0.5	21.42	138.68	3
23130	711	23.12	0.5	21.47	140.28	3

CHANNEL BANDWIDTH: 10MHz 16QAM

Channel	Frequency (MHz)	Conducted Power (dBm)	G _T -L _c (dB)	ERP (dBm)	ERP (mW)	Limit (W)
23060	704	22.33	0.5	20.68	116.95	3
23095	707.5	22.43	0.5	20.78	119.67	3
23130	711	22.37	0.5	20.72	118.03	3

REMARKS: ERP Output Power (dBm) = ERP (dBm) -2.15(dB).



BUREAU
VERITAS

Test Report No.: W7L-P21090022RF06

LTE BAND 13

CHANNEL BANDWIDTH: 5MHz QPSK

Channel	Frequency (MHz)	Conducted Power (dBm)	G _T -L _c (dB)	ERP (dBm)	ERP (mW)	Limit (W)
23205	779.5	21.84	0.5	20.19	104.47	3
23230	782	21.78	0.5	20.13	103.04	3
23255	784.5	21.84	0.5	20.19	104.47	3

CHANNEL BANDWIDTH: 5MHz 16QAM

Channel	Frequency (MHz)	Conducted Power (dBm)	G _T -L _c (dB)	ERP (dBm)	ERP (mW)	Limit (W)
23205	779.5	21.06	0.5	19.41	87.3	3
23230	782	21.11	0.5	19.46	88.31	3
23255	784.5	21.08	0.5	19.43	87.7	3

CHANNEL BANDWIDTH: 10MHz QPSK

Channel	Frequency (MHz)	Conducted Power (dBm)	G _T -L _c (dB)	ERP (dBm)	ERP (mW)	Limit (W)
-	-	-	-	-	-	-
23230	782	21.86	0.5	20.21	104.95	3
-	-	-	-	-	-	-

CHANNEL BANDWIDTH: 10MHz 16QAM

Channel	Frequency (MHz)	Conducted Power (dBm)	G _T -L _c (dB)	ERP (dBm)	ERP (mW)	Limit (W)
-	-	-	-	-	-	-
23230	782	21.13	0.5	19.48	88.72	3
-	-	-	-	-	-	-

REMARKS: ERP Output Power (dBm) = ERP (dBm) -2.15(dB).

LTE BAND 17

CHANNEL BANDWIDTH: 5MHz QPSK

Channel	Frequency (MHz)	Conducted Power (dBm)	G _T -L _c (dB)	ERP (dBm)	ERP (mW)	Limit (W)
23755	706.5	23.09	0.5	21.44	139.32	3
23790	710	22.99	0.5	21.34	136.14	3
23825	713.5	23.08	0.5	21.43	139	3

CHANNEL BANDWIDTH: 5MHz 16QAM

Channel	Frequency (MHz)	Conducted Power (dBm)	G _T -L _c (dB)	ERP (dBm)	ERP (mW)	Limit (W)
23755	706.5	22.28	0.5	20.63	115.61	3
23790	710	22.38	0.5	20.73	118.3	3
23825	713.5	22.29	0.5	20.64	115.88	3

CHANNEL BANDWIDTH: 10MHz QPSK

Channel	Frequency (MHz)	Conducted Power (dBm)	G _T -L _c (dB)	ERP (dBm)	ERP (mW)	Limit (W)
23780	709	23.11	0.5	21.46	139.96	3
23790	710	23.07	0.5	21.42	138.68	3
23800	711	23.1	0.5	21.45	139.64	3

CHANNEL BANDWIDTH: 10MHz 16QAM

Channel	Frequency (MHz)	Conducted Power (dBm)	G _T -L _c (dB)	ERP (dBm)	ERP (mW)	Limit (W)
23780	709	22.32	0.5	20.67	116.68	3
23790	710	22.4	0.5	20.75	118.85	3
23800	711	22.34	0.5	20.69	117.22	3

REMARKS: ERP Output Power (dBm) = ERP (dBm) -2.15(dB).

3.2 FREQUENCY STABILITY MEASUREMENT

3.2.1 LIMITS OF FREQUENCY STABILITY MEASUREMENT

The frequency stability shall be sufficient to ensure that the fundamental emissions stay within the authorized bands of operation.

3.2.2 TEST PROCEDURE

- a. Device is placed at the oven room. The oven room could control the temperatures and humidity. Power warm up is at least 15 min and power applied should perform before recording frequency error.
- b. EUT is connected the external power supply to control the DC input power. The test voltage range is from minimum to maximum working voltage. Each step shall be record the frequency error rate.
- c. The temperature range step is 10 degrees in this test items. All temperature levels shall be hold the $\pm 0.5^{\circ}\text{C}$ during the measurement testing. The each temperature step shall be at least 0.5 hours, consider the EUT could be test under the stability condition.

NOTE: The frequency error was recorded frequency error from the communication simulator.

3.2.3 TEST SETUP

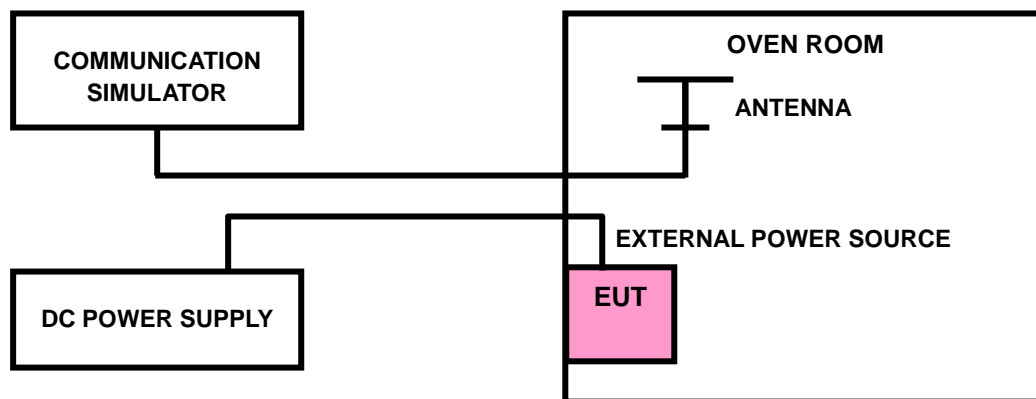



Test Report No.: W7L-P21090022RF06

3.2.4 TEST RESULTS

WCDMA BAND IV

Please Refer to Appendix A 3. of this test report.

LTE BAND 4

Please Refer to Appendix A 3. of this test report.

LTE BAND 12

Please Refer to Appendix A 3. of this test report.

LTE BAND 13

Please Refer to Appendix A 3. of this test report.

LTE BAND 17

Please Refer to Appendix A 3. of this test report.

3.3 OCCUPIED BANDWIDTH MEASUREMENT

3.3.1 LIMITS OF OCCUPIED BANDWIDTH MEASUREMENT

The width of a frequency band such that, below the lower and above the upper frequency limits, the mean powers emitted are each equal to a specified percentage 0.5 %of the total mean power of a given emission.

3.3.2 TEST SETUP

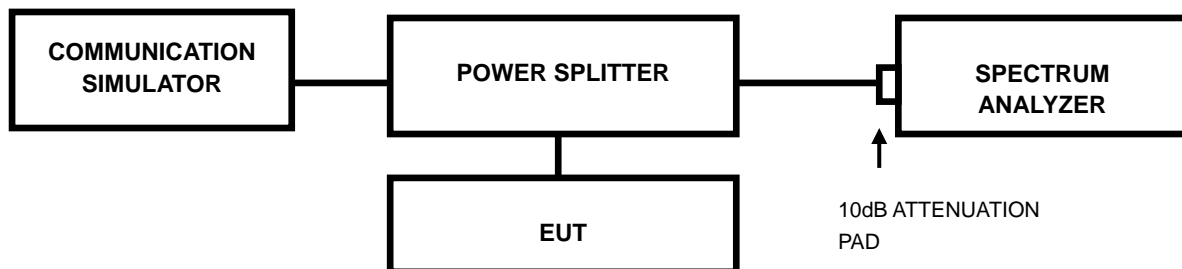

3.3.3 TEST PROCEDURES

- The conducted occupied bandwidth used the power splitter via EUT RF power connector between simulation base station and spectrum analyzer.
- Use OBW measurement function of Spectrum analyzer to measure 99 % occupied bandwidth.



Test Report No.: W7L-P21090022RF06

3.3.4 TEST RESULTS

WCDMA BAND IV

Please Refer to Appendix A 3. of this test report.

LTE BAND 4

Please Refer to Appendix A 3. of this test report.

LTE BAND 12

Please Refer to Appendix A 3. of this test report.

LTE BAND 13

Please Refer to Appendix A 3. of this test report.

LTE BAND 17

Please Refer to Appendix A 3. of this test report.

3.4 BAND EDGE MEASUREMENT

3.4.1 LIMITS OF BAND EDGE MEASUREMENT

According to FCC 27.53(m)(4) specified that For mobile digital stations, the attenuation factor shall be not less than $40 + 10 \log (P)$ dB on all frequencies between the channel edge and 5 megahertz from the channel edge, $43 + 10 \log (P)$ dB on all frequencies between 5 megahertz and X megahertz from the channel edge, and $55 + 10 \log (P)$ dB on all frequencies more than X megahertz from the channel edge, where X is the greater of 6 megahertz or the actual emission bandwidth as defined in paragraph (m)(6) of this section. In addition, the attenuation factor shall not be less that $43 + 10 \log (P)$ dB on all frequencies between 2490.5 MHz and 2496 MHz and $55 + 10 \log (P)$ dB at or below 2490.5 MHz. Mobile Satellite Service licensees operating on frequencies below 2495 MHz may also submit a documented interference complaint against BRS licensees operating on channel BRS Channel 1 on the same terms and conditions as adjacent channel BRS or EBS licensees. For mobile digital stations, in the 1 megahertz bands immediately outside and adjacent to the frequency block a resolution bandwidth of at least two percent may be employed.

3.4.2 TEST SETUP

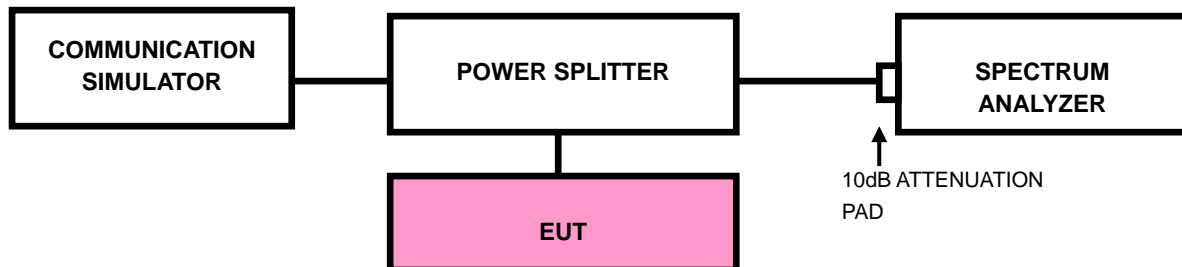



3.4.3 TEST PROCEDURES

- a. The EUT was set up for the maximum peak power with LTE link data modulation. The power was measured with R&S Spectrum Analyzer. All measurements were done at 2 channels (low and high operational frequency range.).
- b. The band edge measurement used the power splitter via EUT RF power connector between simulation base station and spectrum analyzer.
- c. The center frequency of spectrum is the band edge frequency and span is 1~5 MHz. RBW of the spectrum is 20kHz and VBW of the spectrum is 100 kHz. (LTE bandwidth 1.4MHz)
- d. The center frequency of spectrum is the band edge frequency and span is 1~5 MHz. RBW of the spectrum is 30kHz and VBW of the spectrum is 100kHz. (LTE bandwidth 3MHz)
- e. The center frequency of spectrum is the band edge frequency and span is 1~5 MHz. RBW of the spectrum is 50kHz and VBW of the spectrum is 200kHz. (LTE bandwidth 5MHz)
- f. The center frequency of spectrum is the band edge frequency and span is 1~5 MHz. RBW of the spectrum is 100kHz and VBW of the spectrum is 300kHz. (LTE bandwidth 10MHz)
- g. The center frequency of spectrum is the band edge frequency and span is 1~5 MHz. RBW of the spectrum is 150kHz and VBW of the spectrum is 1MHz. (LTE bandwidth 15MHz)
- h. The center frequency of spectrum is the band edge frequency and span is 1~5 MHz. RBW of the spectrum is 200kHz and VBW of the spectrum is 1MHz. (LTE bandwidth 20MHz)
- i. Record the max trace plot into the test report.



Test Report No.: W7L-P21090022RF06

3.4.4 TEST RESULTS

WCDMA BAND IV

Please Refer to Appendix A 3. of this test report.

LTE BAND 4

Please Refer to Appendix A 3. of this test report.

LTE BAND 12

Please Refer to Appendix A 3. of this test report.

LTE BAND 13

Please Refer to Appendix A 3. of this test report.

LTE BAND 17

Please Refer to Appendix A 3. of this test report.

3.5 CONDUCTED SPURIOUS EMISSIONS

3.5.1 LIMITS OF CONDUCTED SPURIOUS EMISSIONS MEASUREMENT

The power of any emission outside a licensee's frequency block shall be attenuated below the transmitter power (P) by at least $55 + 10 \log_{10}(P)$ dB. The limit of emission is equal to -25dBm.

3.5.2 TEST PROCEDURE

- a. The EUT makes a phone call to the communication simulator. All measurements were done at low, middle and high operational frequency range.
- b. Measuring frequency range is from 30MHz~27GHz for LTE Band 7 & 30MHz~26.2GHz for LTE Band 38, 30MHz~27GHz for LTE Band 41. 10dB attenuation pad is connected with spectrum. RBW=1MHz and VBW=3MHz are used for conducted emission measurement.

3.5.3 TEST SETUP

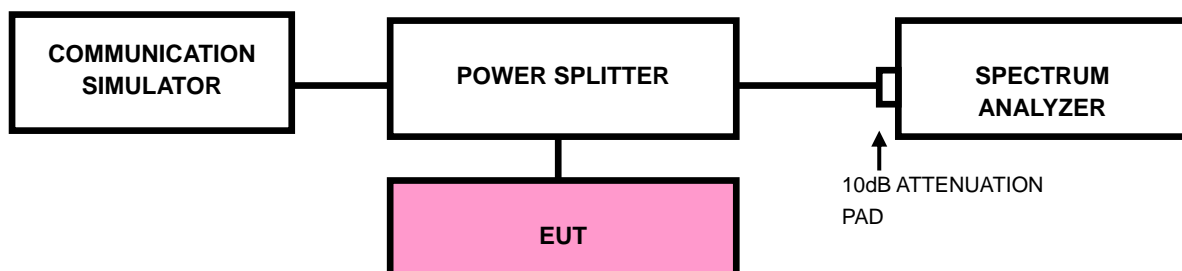



Test Report No.: W7L-P21090022RF06

3.5.4 TEST RESULTS

WCDMA BAND IV

Please Refer to Appendix A 3. of this test report.

LTE BAND 4

Please Refer to Appendix A 3. of this test report.

LTE BAND 12

Please Refer to Appendix A 3. of this test report.

LTE BAND 13

Please Refer to Appendix A 3. of this test report.

LTE BAND 17

Please Refer to Appendix A 3. of this test report.



3.6 RADIATED EMISSION MEASUREMENT

3.6.1 LIMITS OF RADIATED EMISSION MEASUREMENT

The power of any emission outside a licensee's frequency block shall be attenuated below the transmitter power (P) by at least $55 + 10 \log_{10}(P)$ dB. The limit of emission is equal to -25dBm.

3.6.2 TEST PROCEDURES

- a. Substitution method is used for E.I.R.P measurement. In the semi-anechoic chamber, EUT placed on the 0.8m height of Turn Table, rotated the table around 360 degrees to search the maximum radiation power and receiver antenna shall be rotated vertical and horizontal polarization and moved height from 1m to 4m to find the maximum polar radiated power. The "Read Value" is the spectrum reading the maximum power value.
- b. The substitution horn antenna is substituted for EUT at the same position and signals generator export the CW signal to the substitution antenna via a TX cable. Rotated the Turn Table and moved receiving antenna to find the maximum radiation power. Adjust output power level of S.G to get a Value of spectrum reading equal to "Read Value " of step a. Record the power level of S.G.
- c. $EIRP = \text{Output power level of S.G} - \text{TX cable loss} + \text{Antenna gain of substitution horn}$.
- d. E.R.P power can be calculated form E.I.R.P power by subtracting the gain of dipole, $E.R.P \text{ power} = E.I.P.R \text{ power} - 2.15\text{dBi}$.

NOTE: The resolution bandwidth of spectrum analyzer is 1 MHz and the video bandwidth is 3 MHz.

3.6.3 DEVIATION FROM TEST STANDARD

No deviation

3.6.4 TEST SETUP

< Frequency Range 30MHz~1GHz >

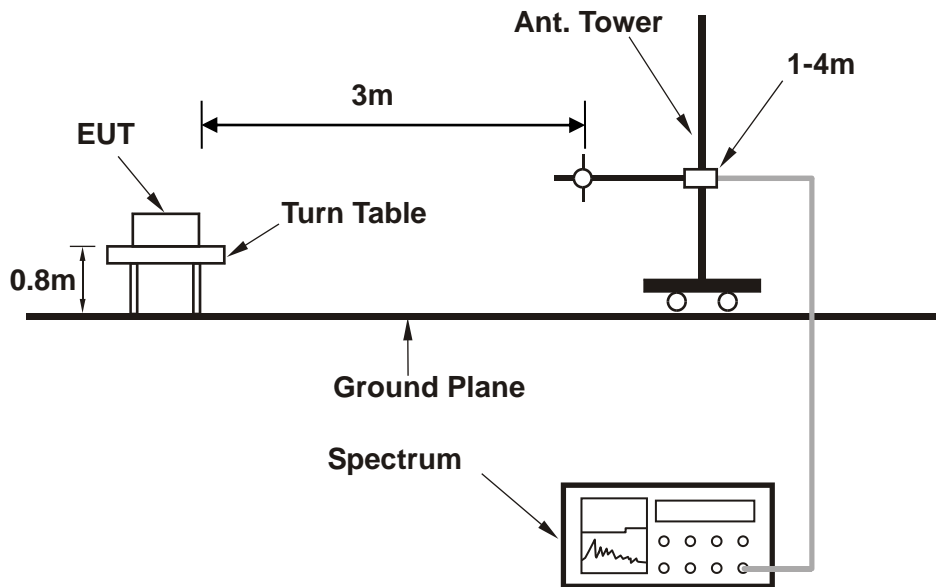

<Frequency Range above 1GHz>

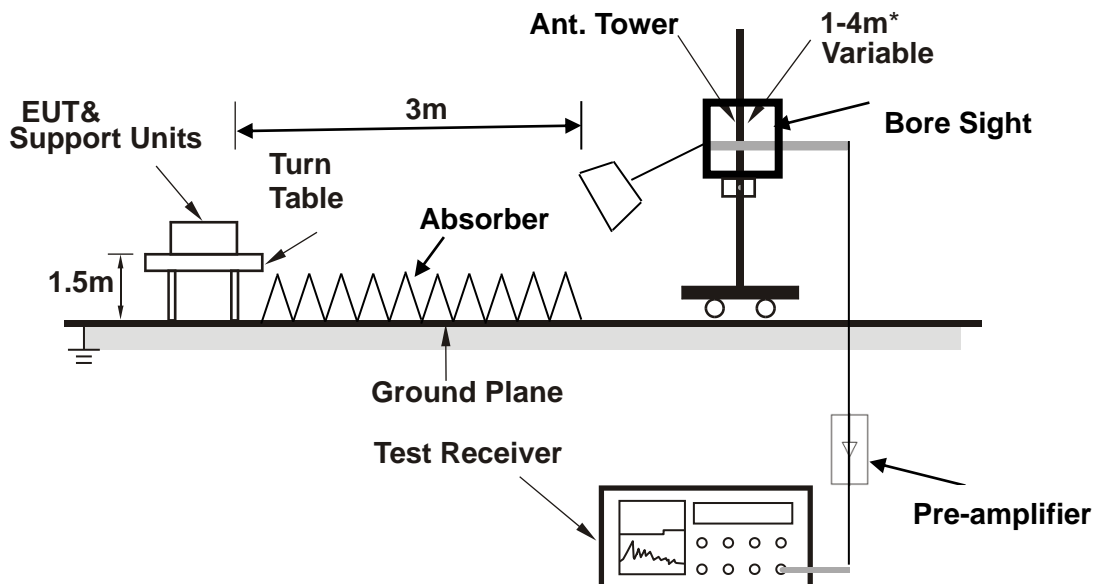

Note: Above 1G is a directional antenna depends on the EUT height and the antenna 3dB beamwidth both, refer to section 7.3 of CISPR 16-2-3.

For the actual test configuration, please refer to the attached file (Test Setup Photo).



3.6.5 TEST RESULTS

BELOW 1GHz WORST-CASE DATA

30 MHz – 1GHz data:

LTE Band 4

CHANNEL BANDWIDTH: 1.4MHz / QPSK

MODE	TX channel 19957	FREQUENCY RANGE	Below 1000MHz
ENVIRONMENTAL CONDITIONS	23deg. C, 70%RH	INPUT POWER	AC 120V/60Hz
TESTED BY	Jace Hu		
ANTENNA POLARITY & TEST DISTANCE: HORIZONTAL AT 3 M			

	Freq	Level	Read Level	Limit Line	Over Limit	Factor	Remark	Pol/Phase
	MHz	dBm/m	dBm	dBm/m	dB	dB/m		
1	71.710	-23.45	-31.18	-13.00	-10.45	7.73	Peak	Horizontal
2	150.280	-32.44	-42.08	-13.00	-19.44	9.64	Peak	Horizontal
3	213.330	-35.37	-46.96	-13.00	-22.37	11.59	Peak	Horizontal
4	337.490	-43.04	-58.13	-13.00	-30.04	15.09	Peak	Horizontal
5	423.820	-42.51	-59.84	-13.00	-29.51	17.33	Peak	Horizontal
6	562.530	-44.09	-64.04	-13.00	-31.09	19.95	Peak	Horizontal

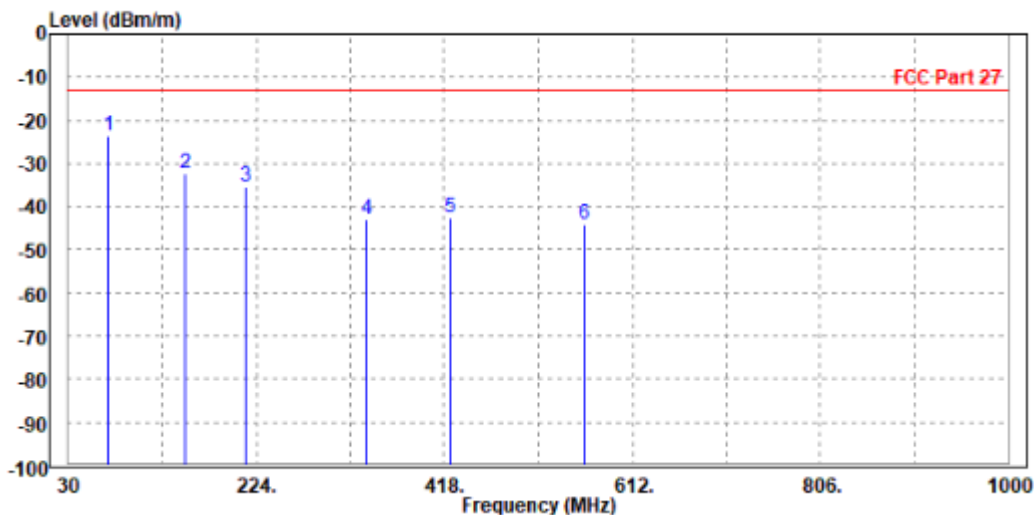



Test Report No.: W7L-P21090022RF06

MODE	TX channel 19957	FREQUENCY RANGE	Below 1000MHz
ENVIRONMENTAL CONDITIONS	23deg. C, 70%RH	INPUT POWER	AC 120V/60Hz
TESTED BY	Jace Hu		
ANTENNA POLARITY & TEST DISTANCE: VERTICAL AT 3 M			

	Freq	Level	Read Level	Limit Line	Over Limit	Factor	Remark	Pol/Phase
	MHz	dBm/m	dBm	dBm/m	dB	dB/m		
1	33.880	-25.32	-43.81	-13.00	-12.32	18.49	Peak	Vertical
2 PP	71.710	-22.92	-30.89	-13.00	-9.92	7.97	Peak	Vertical
3	154.160	-34.79	-45.41	-13.00	-21.79	10.62	Peak	Vertical
4	206.540	-40.53	-52.33	-13.00	-27.53	11.80	Peak	Vertical
5	344.280	-44.05	-60.02	-13.00	-31.05	15.97	Peak	Vertical
6	594.540	-42.82	-63.62	-13.00	-29.82	20.80	Peak	Vertical

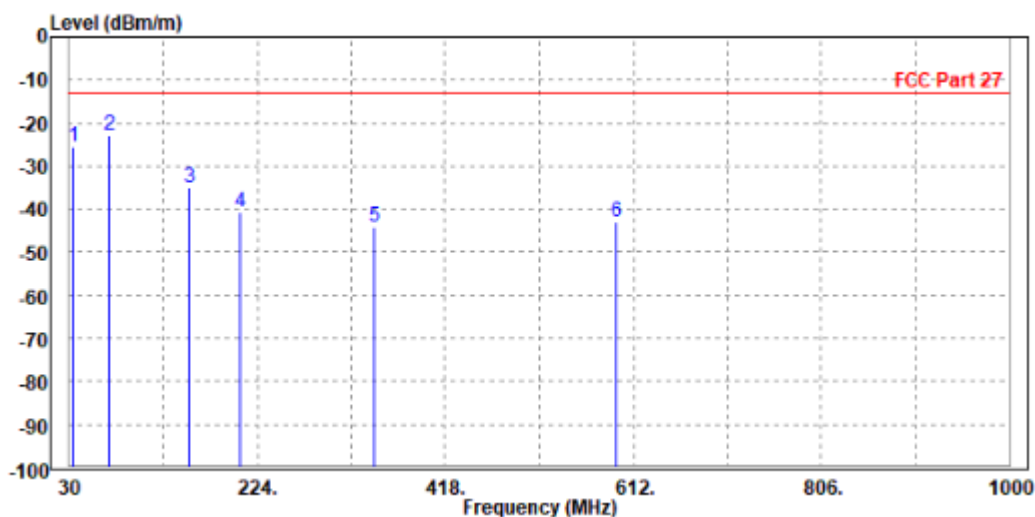



BUREAU VERITAS

Test Report No.: W7L-P21090022RF06

ABOVE 1GHz

Note: For higher frequency, the emission is too low to be detected.

WORST-CASE DATA

WCDMA Band IV:

CH 1312

MODE	TX channel 1312	FREQUENCY RANGE	Above 1000MHz
ENVIRONMENTAL CONDITIONS	23deg. C, 70%RH	INPUT POWER	AC 120V/60Hz
TESTED BY	Jace Hu		
ANTENNA POLARITY & TEST DISTANCE: HORIZONTAL AT 3 M			

	Freq	Level	Read Level	Limit Line	Over Limit	Factor	Remark	Pol/Phase
	MHz	dBm/m	dBm	dBm/m	dB	dB/m		
1 PP	3418.000	-47.35	-55.94	-13.00	-34.35	8.59	Peak	Horizontal
2	5137.200	-48.16	-57.10	-13.00	-35.16	8.94	Peak	Horizontal

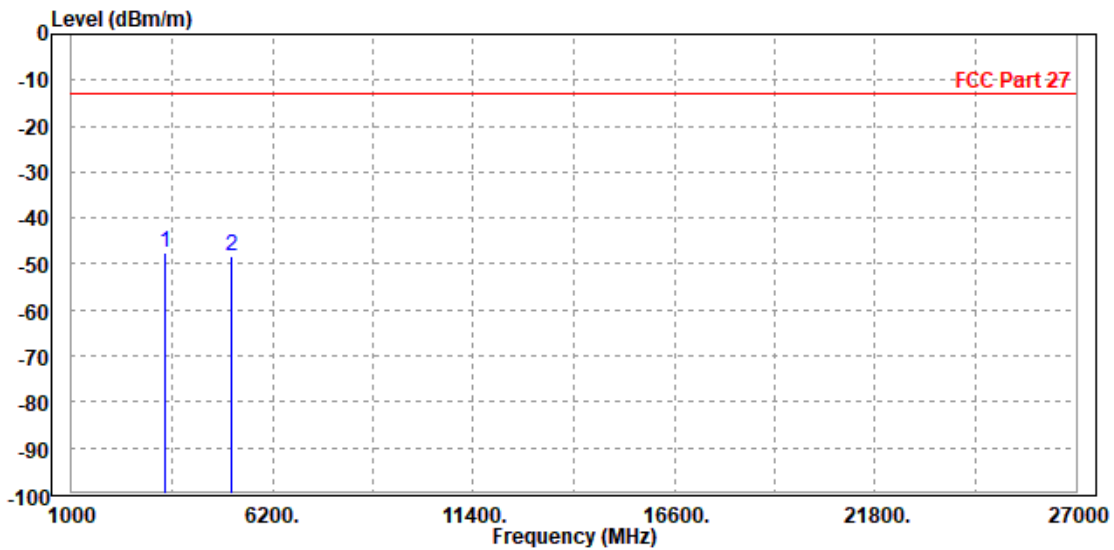



Test Report No.: W7L-P21090022RF06

MODE	TX channel 1312	FREQUENCY RANGE	Above 1000MHz
ENVIRONMENTAL CONDITIONS	23deg. C, 70%RH	INPUT POWER	AC 120V/60Hz
TESTED BY	Jace Hu		
ANTENNA POLARITY & TEST DISTANCE: VERTICAL AT 3 M			

	Freq	Level	Read Level	Limit Line	Over Limit	Factor	Remark	Pol/Phase
	MHz	dBm/m	dBm	dBm/m	dB	dB/m		
1	PP 3424.800	-46.39	-55.51	-13.00	-33.39	9.12	Peak	Vertical
2	5134.000	-47.69	-57.54	-13.00	-34.69	9.85	Peak	Vertical

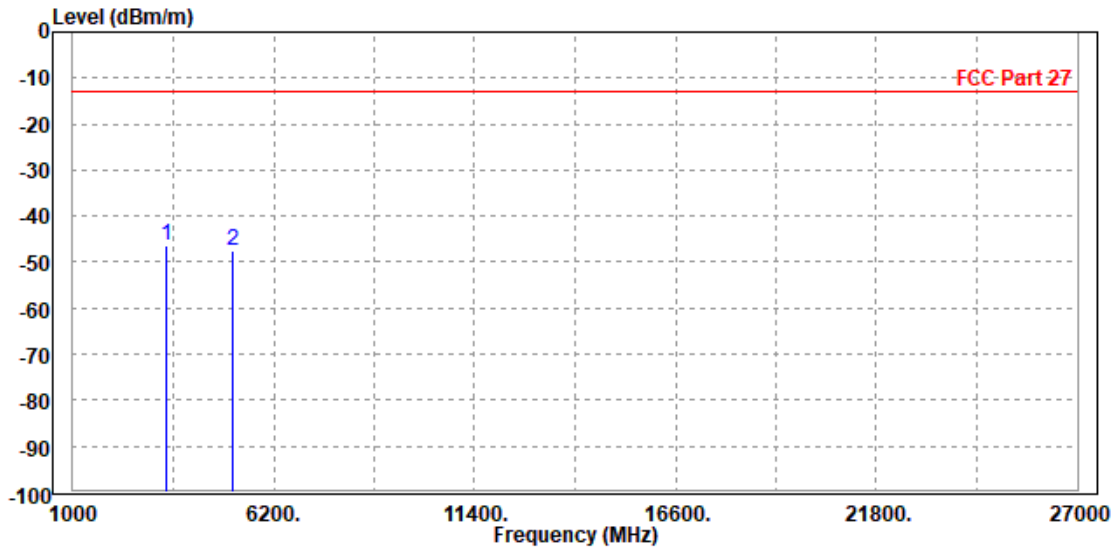



Test Report No.: W7L-P21090022RF06

CH 1413

MODE	TX channel 1413	FREQUENCY RANGE	Above 1000MHz
ENVIRONMENTAL CONDITIONS	23deg. C, 70%RH	INPUT POWER	AC 120V/60Hz
TESTED BY	Jace Hu		
ANTENNA POLARITY & TEST DISTANCE: HORIZONTAL AT 3 M			

	Freq	Level	Read Level	Limit Line	Over Limit	Factor	Remark	Pol/Phase
	MHz	dBm/m	dBm	dBm/m	dB	dB/m		
1	3470.000	-47.67	-56.25	-13.00	-34.67	8.58	Peak	Horizontal
2 PP	5197.800	-47.25	-56.37	-13.00	-34.25	9.12	Peak	Horizontal

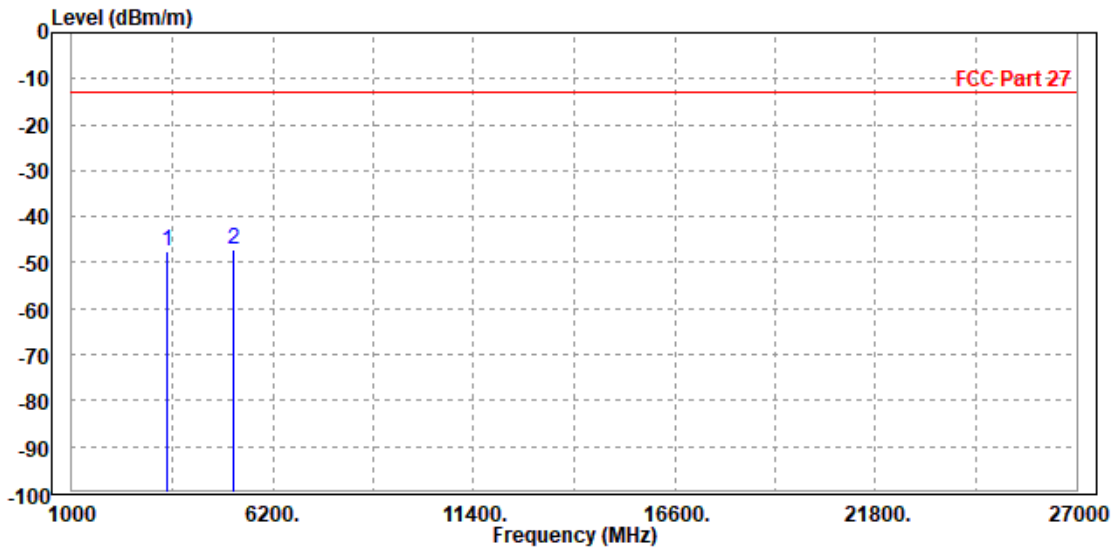



Test Report No.: W7L-P21090022RF06

MODE	TX channel 1413	FREQUENCY RANGE	Above 1000MHz
ENVIRONMENTAL CONDITIONS	23deg. C, 70%RH	INPUT POWER	AC 120V/60Hz
TESTED BY	Jace Hu		
ANTENNA POLARITY & TEST DISTANCE: VERTICAL AT 3 M			

	Freq	Level	Read Level	Limit Line	Over Limit	Factor	Remark	Pol/Phase
	MHz	dBm/m	dBm	dBm/m	dB	dB/m		
1	3470.000	-47.25	-56.41	-13.00	-34.25	9.16	Peak	Vertical
2 PP	5197.800	-42.58	-52.40	-13.00	-29.58	9.82	Peak	Vertical

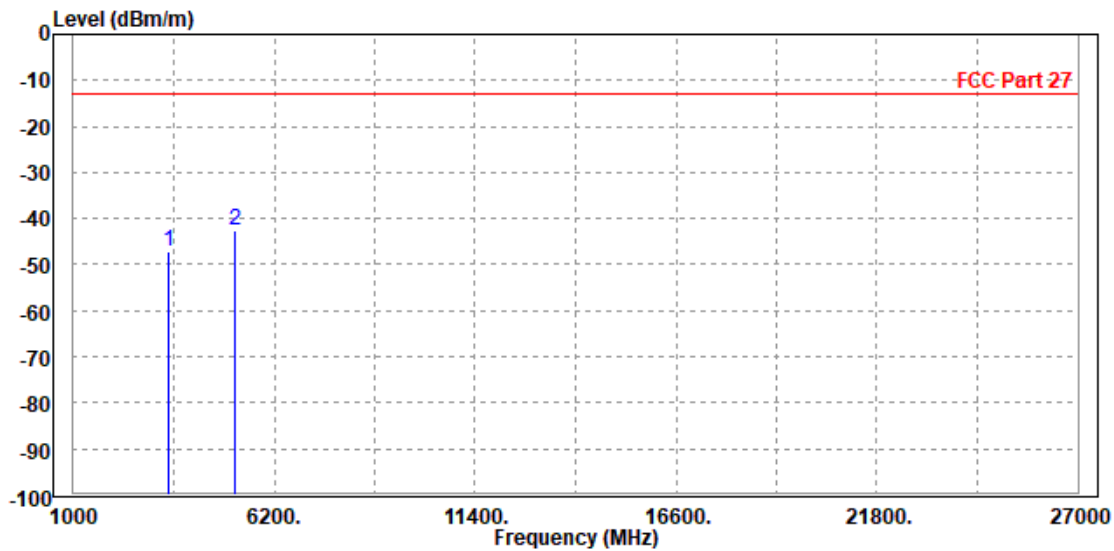



Test Report No.: W7L-P21090022RF06

CH 1513

MODE	TX channel 1513	FREQUENCY RANGE	Above 1000MHz
ENVIRONMENTAL CONDITIONS	23deg. C, 70%RH	INPUT POWER	AC 120V/60Hz
TESTED BY	Jace Hu		
ANTENNA POLARITY & TEST DISTANCE: HORIZONTAL AT 3 M			

	Freq	Level	Read Level	Limit Line	Over Limit	Factor	Remark	Pol/Phase
	MHz	dBm/m	dBm	dBm/m	dB	dB/m		
1	PP 3496.000	-43.60	-52.17	-13.00	-30.60	8.57	Peak	Horizontal
2	5257.800	-49.02	-58.32	-13.00	-36.02	9.30	Peak	Horizontal

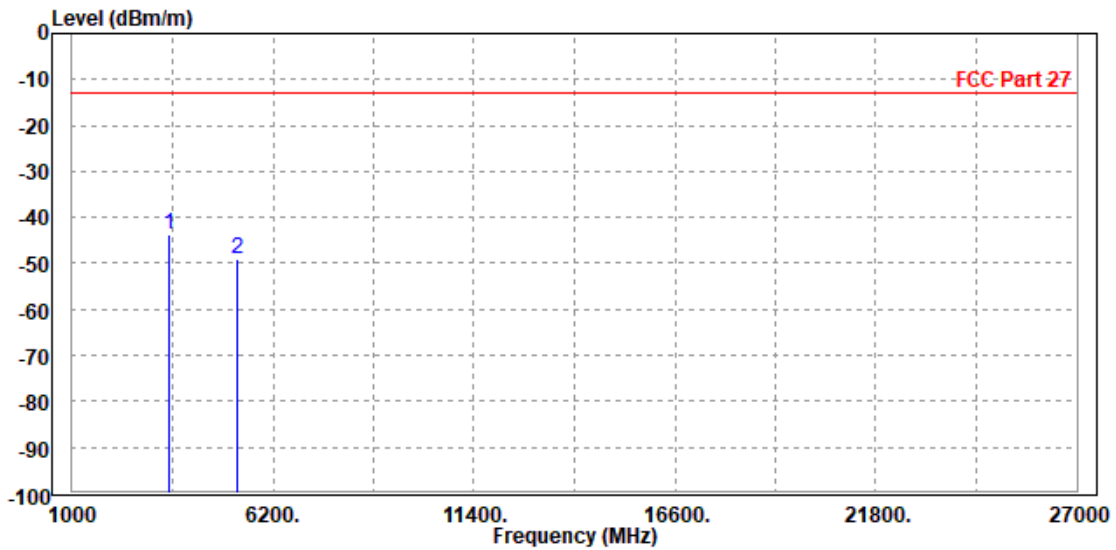



Test Report No.: W7L-P21090022RF06

MODE	TX channel 1513	FREQUENCY RANGE	Above 1000MHz
ENVIRONMENTAL CONDITIONS	23deg. C, 70%RH	INPUT POWER	AC 120V/60Hz
TESTED BY	Jace Hu		
ANTENNA POLARITY & TEST DISTANCE: VERTICAL AT 3 M			

	Freq	Level	Read Level	Limit Line	Over Limit	Factor	Remark	Pol/Phase
	MHz	dBm/m	dBm	dBm/m	dB	dB/m		
1 PP	3496.000	-40.73	-49.92	-13.00	-27.73	9.19	Peak	Vertical
2	5257.800	-48.31	-58.11	-13.00	-35.31	9.80	Peak	Vertical

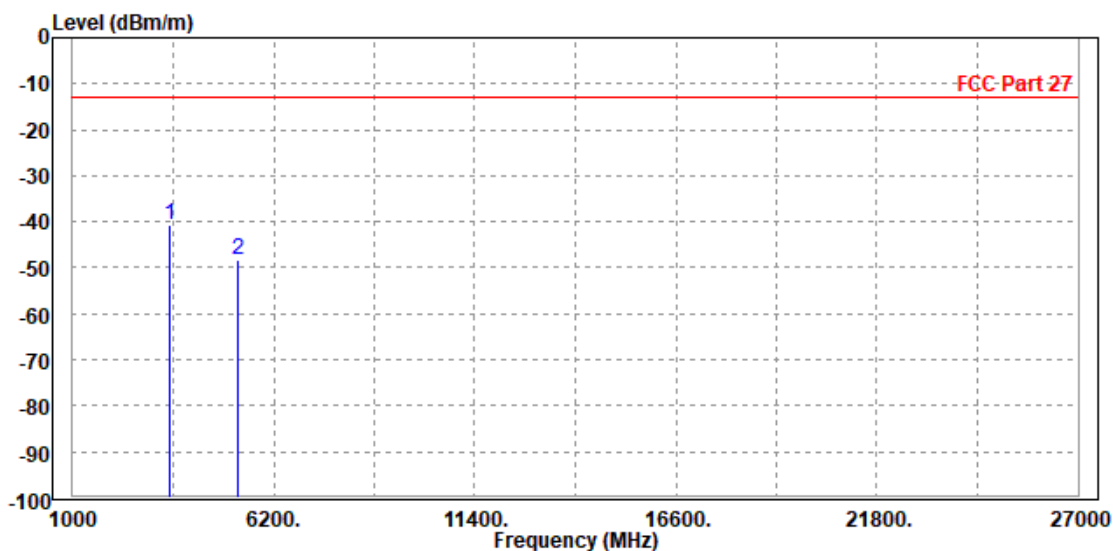



Test Report No.: W7L-P21090022RF06

LTE Band 4
 CHANNEL BANDWIDTH: 1.4MHz / QPSK
 CH 19957

MODE	TX channel 19957	FREQUENCY RANGE	Above 1000MHz
ENVIRONMENTAL CONDITIONS	23deg. C, 70%RH	INPUT POWER	AC 120V/60Hz
TESTED BY	Jace Hu		
ANTENNA POLARITY & TEST DISTANCE: HORIZONTAL AT 3 M			

	Freq	Level	Read Level	Limit	Over Limit	Factor	Remark	Pol/Phase
	MHz	dBm/m	dBm	dBm/m	dB	dB/m		
1	3418.000	-47.65	-56.24	-13.00	-34.65	8.59	Peak	Horizontal
2 PP	5132.100	-47.34	-56.26	-13.00	-34.34	8.92	Peak	Horizontal

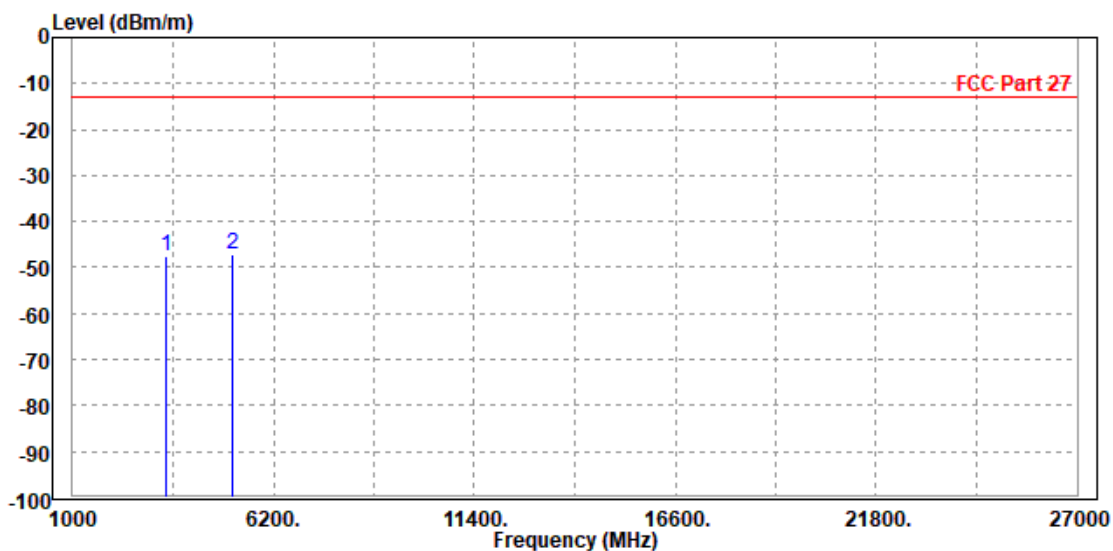



Test Report No.: W7L-P21090022RF06

MODE	TX channel 19957	FREQUENCY RANGE	Above 1000MHz
ENVIRONMENTAL CONDITIONS	23deg. C, 70%RH	INPUT POWER	AC 120V/60Hz
TESTED BY	Jace Hu		
ANTENNA POLARITY & TEST DISTANCE: VERTICAL AT 3 M			

	Freq	Level	Read Level	Limit Line	Over Limit	Factor	Remark	Pol/Phase
	MHz	dBm/m	dBm	dBm/m	dB	dB/m		
1	3418.000	-47.80	-56.91	-13.00	-34.80	9.11	Peak	Vertical
2	PP 5132.100	-45.97	-55.82	-13.00	-32.97	9.85	Peak	Vertical

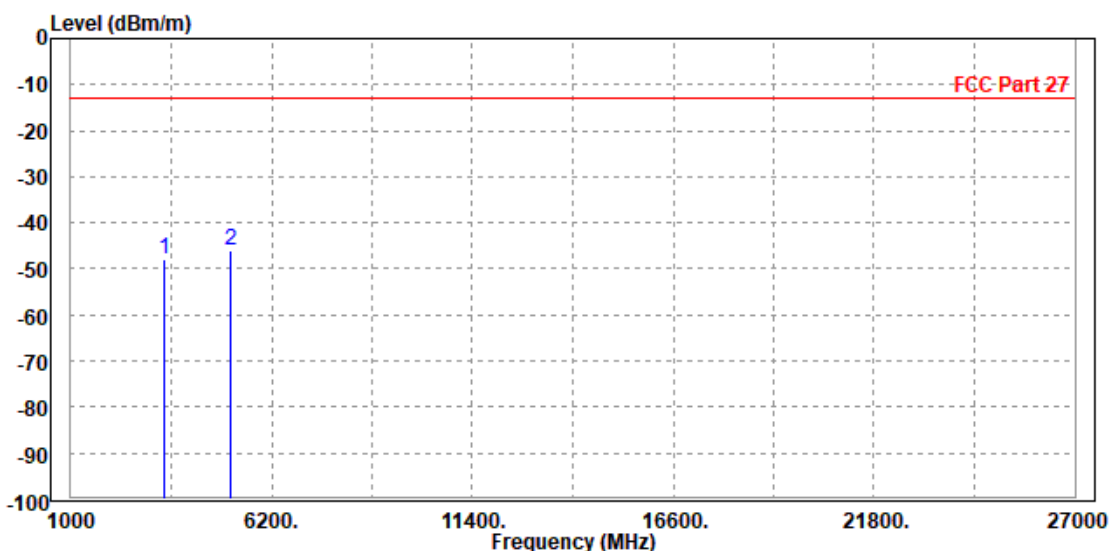



BUREAU
VERITAS

Test Report No.: W7L-P21090022RF06

CH 20175

MODE	TX channel 20175	FREQUENCY RANGE	Above 1000MHz
ENVIRONMENTAL CONDITIONS	23deg. C, 70%RH	INPUT POWER	AC 120V/60Hz
TESTED BY	Jace Hu		
ANTENNA POLARITY & TEST DISTANCE: HORIZONTAL AT 3 M			

	Freq	Level	Read Level	Limit	Over Limit	Factor	Remark	Pol/Phase
	MHz	dBm/m	dBm	dBm/m	dB	dB/m		
1	3470.000	-47.94	-56.52	-13.00	-34.94	8.58	Peak	Horizontal
2	PP 5197.500	-44.05	-53.17	-13.00	-31.05	9.12	Peak	Horizontal

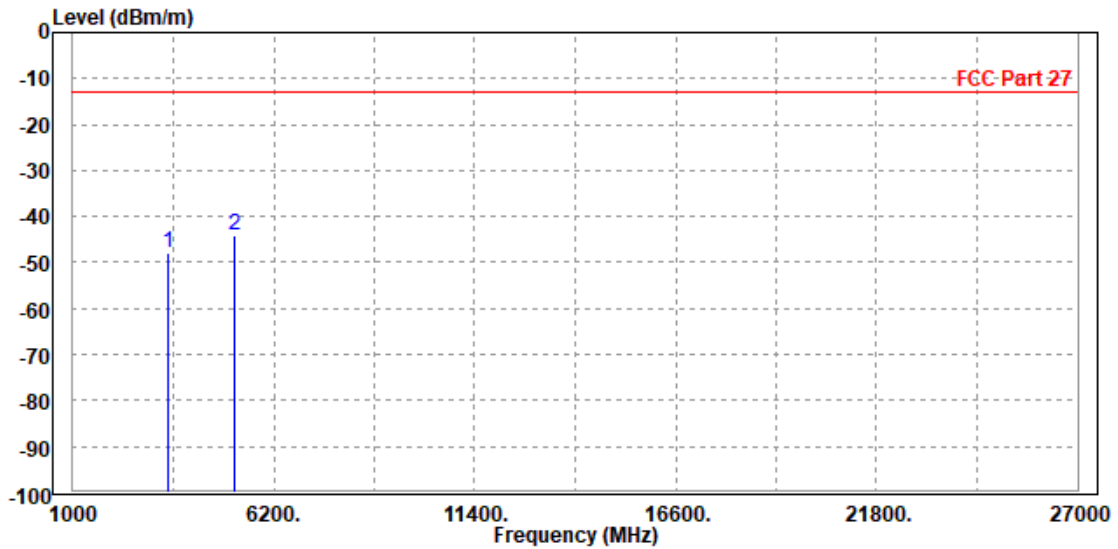



Test Report No.: W7L-P21090022RF06

MODE	TX channel 20175	FREQUENCY RANGE	Above 1000MHz
ENVIRONMENTAL CONDITIONS	23deg. C, 70%RH	INPUT POWER	AC 120V/60Hz
TESTED BY	Jace Hu		
ANTENNA POLARITY & TEST DISTANCE: VERTICAL AT 3 M			

	Freq	Level	Read Level	Limit Line	Over Limit	Factor	Remark	Pol/Phase
	MHz	dBm/m	dBm	dBm/m	dB	dB/m		
1	3470.000	-46.75	-55.91	-13.00	-33.75	9.16	Peak	Vertical
2	PP 5197.500	-45.92	-55.74	-13.00	-32.92	9.82	Peak	Vertical

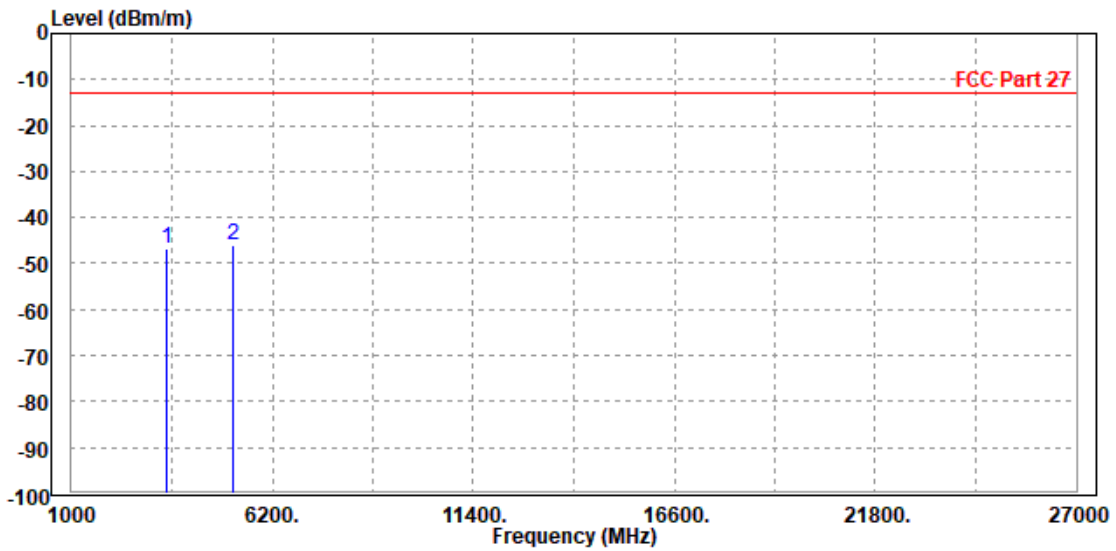



**BUREAU
VERITAS**

Test Report No.: W7L-P21090022RF06

CH 20393

MODE	TX channel 20393	FREQUENCY RANGE	Above 1000MHz
ENVIRONMENTAL CONDITIONS	23deg. C, 70%RH	INPUT POWER	AC 120V/60Hz
TESTED BY	Jace Hu		
ANTENNA POLARITY & TEST DISTANCE: HORIZONTAL AT 3 M			

	Freq	Level	Read Level	Limit Line	Over Limit	Factor	Remark	Pol/Phase
	MHz	dBm/m	dBm	dBm/m	dB	dB/m		
1	PP 3496.000	-46.89	-55.46	-13.00	-33.89	8.57	Peak	Horizontal
2	5262.900	-48.37	-57.68	-13.00	-35.37	9.31	Peak	Horizontal

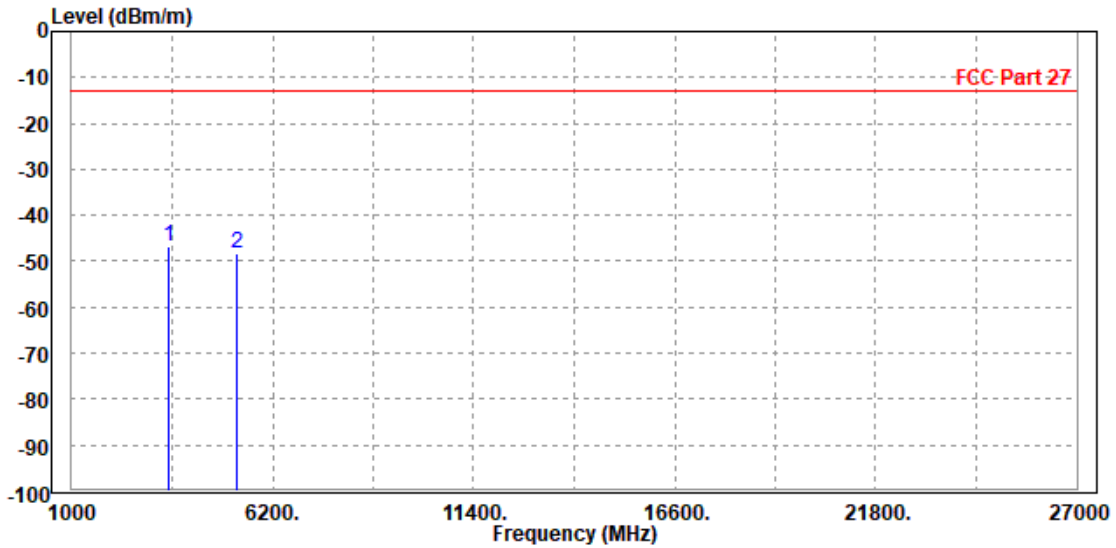



Test Report No.: W7L-P21090022RF06

MODE	TX channel 20393	FREQUENCY RANGE	Above 1000MHz
ENVIRONMENTAL CONDITIONS	23deg. C, 70%RH	INPUT POWER	AC 120V/60Hz
TESTED BY	Jace Hu		
ANTENNA POLARITY & TEST DISTANCE: VERTICAL AT 3 M			

	Freq	Level	Read Level	Limit Line	Over Limit	Factor	Remark	Pol/Phase
	MHz	dBm/m	dBm	dBm/m	dB	dB/m		
1	PP 3496.000	-44.90	-54.09	-13.00	-31.90	9.19	Peak	Vertical
2	5262.900	-47.25	-57.05	-13.00	-34.25	9.80	Peak	Vertical

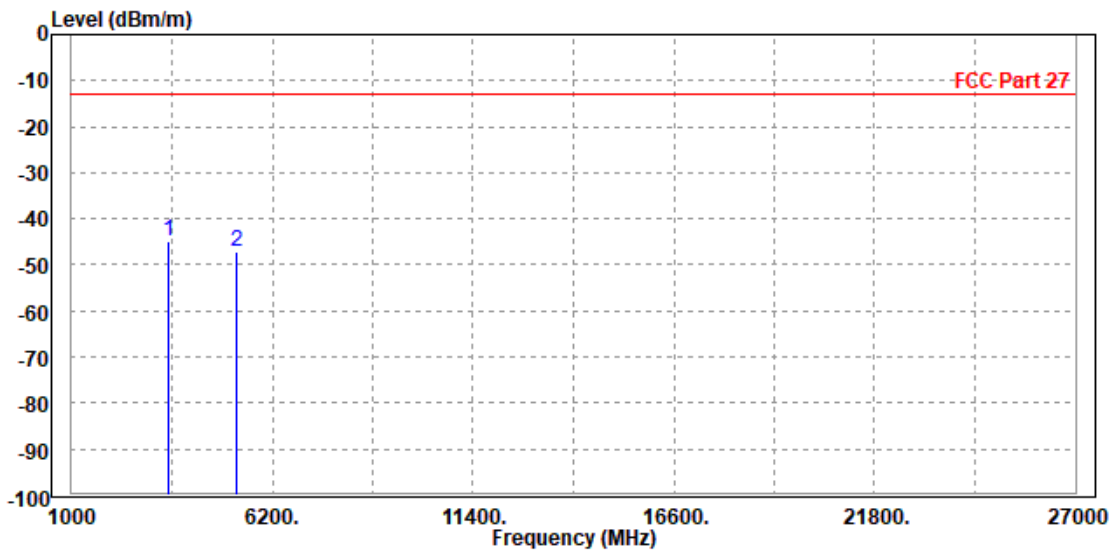



**BUREAU
VERITAS**

Test Report No.: W7L-P21090022RF06

CHANNEL BANDWIDTH: 3MHz / QPSK

CH 20175

MODE	TX channel 20175	FREQUENCY RANGE	Above 1000MHz
ENVIRONMENTAL CONDITIONS	23deg. C, 70%RH	INPUT POWER	AC 120V/60Hz
TESTED BY	Jace Hu		
ANTENNA POLARITY & TEST DISTANCE: HORIZONTAL AT 3 M			

	Freq	Level	Read Level	Limit Line	Over Limit	Factor	Remark	Pol/Phase
	MHz	dBm/m	dBm	dBm/m	dB	dB/m		
1	3470.000	-48.36	-56.94	-13.00	-35.36	8.58	Peak	Horizontal
2 PP	5197.500	-47.85	-56.97	-13.00	-34.85	9.12	Peak	Horizontal

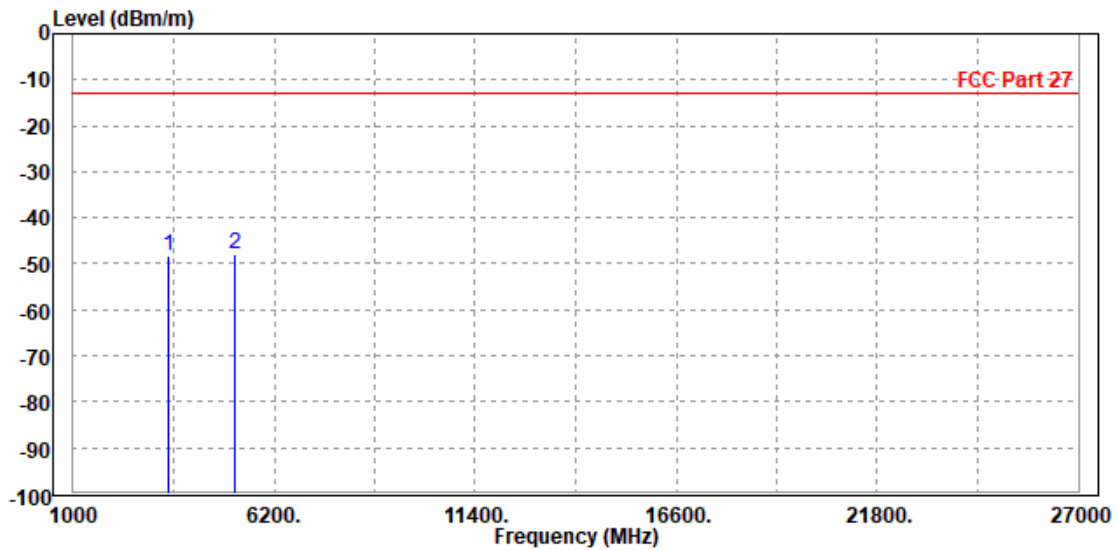



Test Report No.: W7L-P21090022RF06

MODE	TX channel 20175	FREQUENCY RANGE	Above 1000MHz
ENVIRONMENTAL CONDITIONS	23deg. C, 70%RH	INPUT POWER	AC 120V/60Hz
TESTED BY	Jace Hu		
ANTENNA POLARITY & TEST DISTANCE: VERTICAL AT 3 M			

	Freq	Level	Read Level	Limit Line	Over Limit	Factor	Remark	Pol/Phase
	MHz	dBm/m	dBm	dBm/m	dB	dB/m		
1	PP 3470.000	-47.20	-56.36	-13.00	-34.20	9.16	Peak	Vertical
2	5197.500	-49.16	-58.98	-13.00	-36.16	9.82	Peak	Vertical

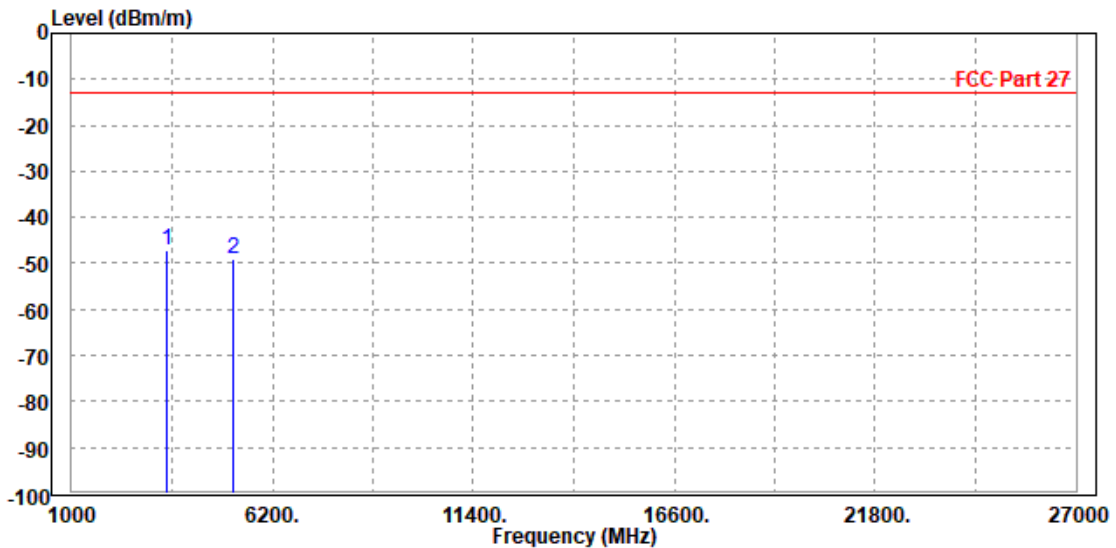



**BUREAU
VERITAS**

Test Report No.: W7L-P21090022RF06

CHANNEL BANDWIDTH: 5MHz / QPSK

CH 20175

MODE	TX channel 20175	FREQUENCY RANGE	Above 1000MHz
ENVIRONMENTAL CONDITIONS	23deg. C, 70%RH	INPUT POWER	AC 120V/60Hz
TESTED BY	Jace Hu		
ANTENNA POLARITY & TEST DISTANCE: HORIZONTAL AT 3 M			

	Freq	Level	Read Level	Limit Line	Over Limit	Factor	Remark	Pol/Phase
	MHz	dBm/m	dBm	dBm/m	dB	dB/m		
1	PP 3470.000	-47.36	-55.94	-13.00	-34.36	8.58	Peak	Horizontal
2	5197.500	-49.53	-58.65	-13.00	-36.53	9.12	Peak	Horizontal

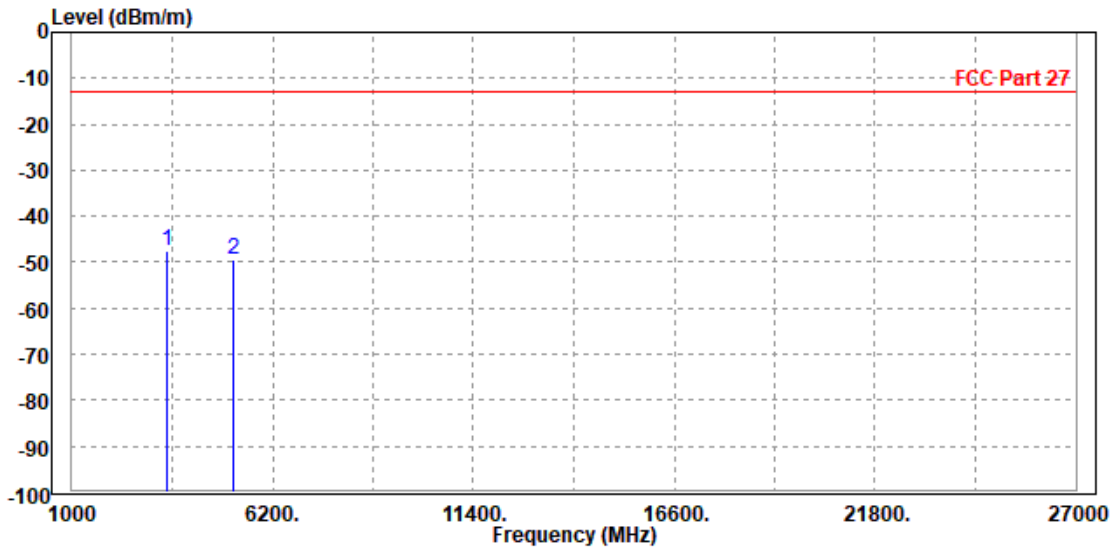



Test Report No.: W7L-P21090022RF06

MODE	TX channel 20175	FREQUENCY RANGE	Above 1000MHz
ENVIRONMENTAL CONDITIONS	23deg. C, 70%RH	INPUT POWER	AC 120V/60Hz
TESTED BY	Jace Hu		
ANTENNA POLARITY & TEST DISTANCE: VERTICAL AT 3 M			

	Freq	Read Level	Limit Level	Over Limit	Factor	Remark	Pol/Phase
	MHz	dBm/m	dBm	dBm/m	dB	dB/m	
1	PP 3470.000	-47.64	-56.80	-13.00	-34.64	9.16 Peak	Vertical
2	5197.500	-47.85	-57.67	-13.00	-34.85	9.82 Peak	Vertical

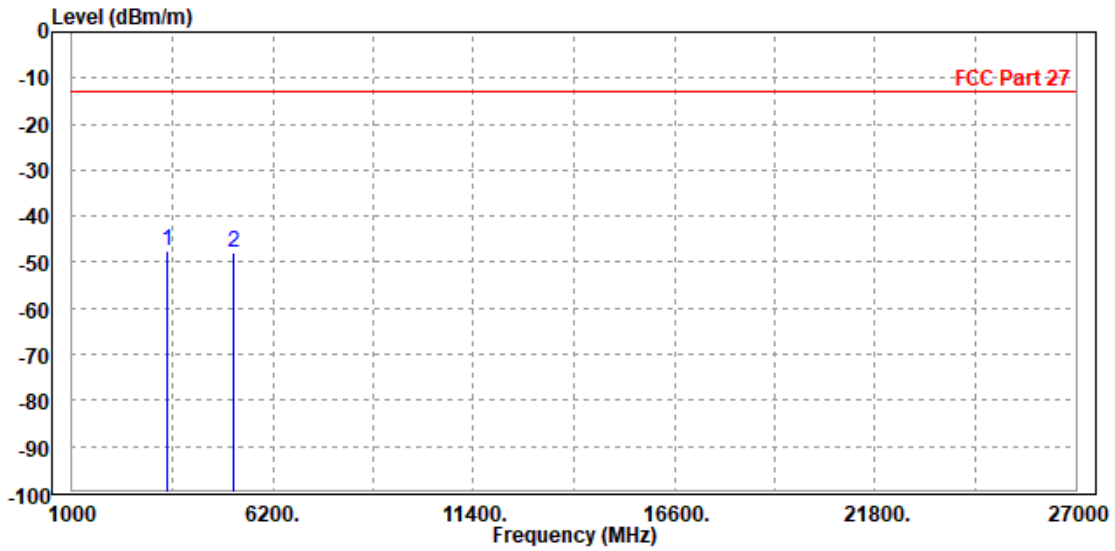



BUREAU
VERITAS

Test Report No.: W7L-P21090022RF06

CHANNEL BANDWIDTH: 10MHz / QPSK

MODE	TX channel 20175	FREQUENCY RANGE	Above 1000MHz
ENVIRONMENTAL CONDITIONS	23deg. C, 70%RH	INPUT POWER	AC 120V/60Hz
TESTED BY	Jace Hu		
ANTENNA POLARITY & TEST DISTANCE: HORIZONTAL AT 3 M			

	Freq	Level	Read Level	Limit Line	Over Limit	Factor	Remark	Pol/Phase
	MHz	dBm/m	dBm	dBm/m	dB	dB/m		
1	PP 3470.000	-48.18	-56.76	-13.00	-35.18	8.58	Peak	Horizontal
2	5197.500	-48.76	-57.88	-13.00	-35.76	9.12	Peak	Horizontal

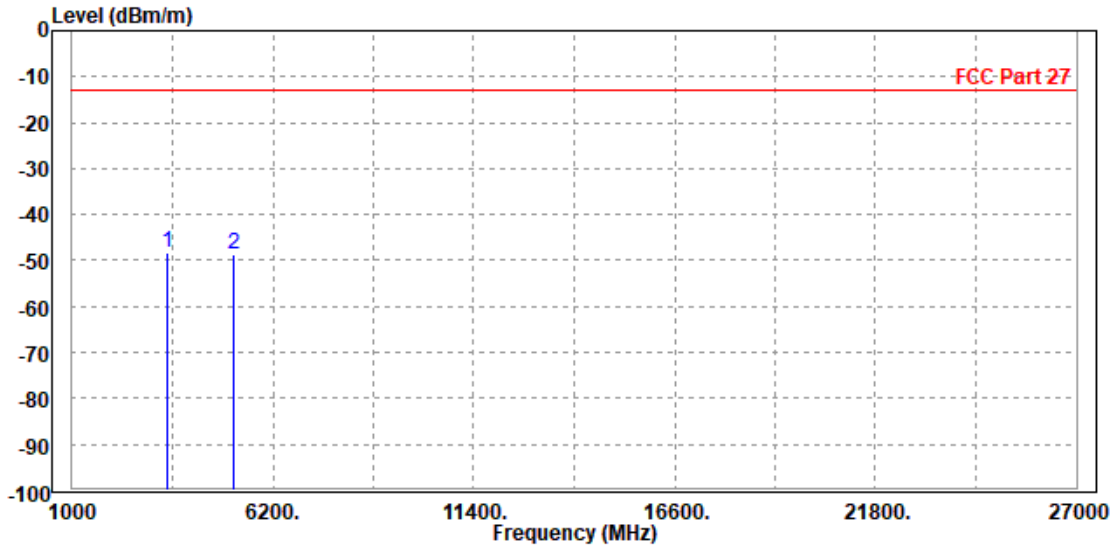



Test Report No.: W7L-P21090022RF06

MODE	TX channel 20175	FREQUENCY RANGE	Above 1000MHz
ENVIRONMENTAL CONDITIONS	23deg. C, 70%RH	INPUT POWER	AC 120V/60Hz
TESTED BY	Jace Hu		
ANTENNA POLARITY & TEST DISTANCE: VERTICAL AT 3 M			

	Freq	Level	Read Level	Limit Line	Over Limit	Factor	Remark	Pol/Phase
	MHz	dBm/m	dBm	dBm/m	dB	dB/m		
1	PP 3470.000	-46.52	-55.68	-13.00	-33.52	9.16	Peak	Vertical
2	5197.500	-46.92	-56.74	-13.00	-33.92	9.82	Peak	Vertical

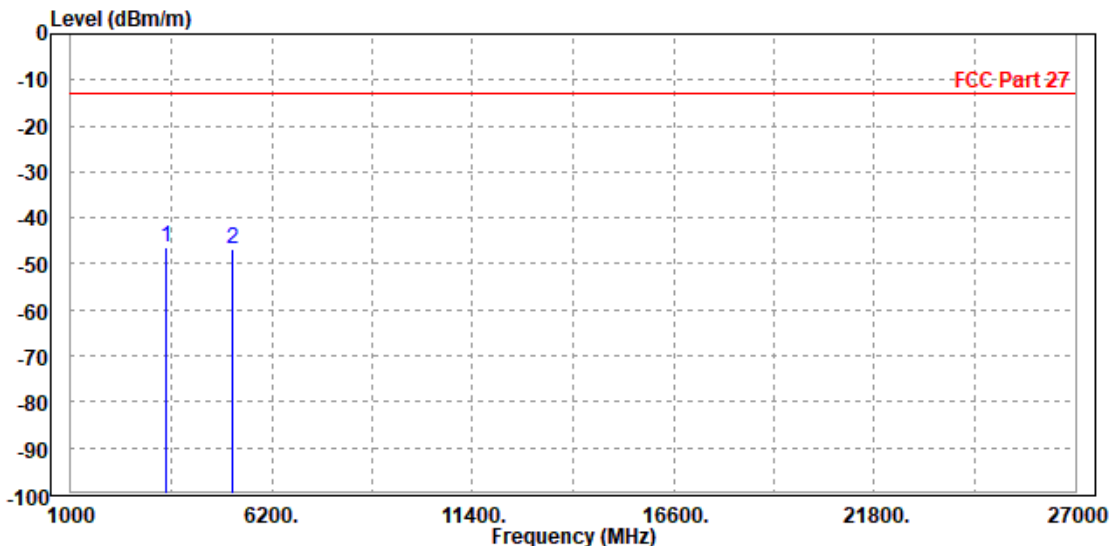



**BUREAU
VERITAS**

Test Report No.: W7L-P21090022RF06

CHANNEL BANDWIDTH: 15MHz / QPSK

CH20175

MODE	TX channel 20175	FREQUENCY RANGE	Above 1000MHz
ENVIRONMENTAL CONDITIONS	23deg. C, 70%RH	INPUT POWER	AC 120V/60Hz
TESTED BY	Jace Hu		
ANTENNA POLARITY & TEST DISTANCE: HORIZONTAL AT 3 M			

	Freq	Level	Read Level	Limit Line	Over Limit	Factor	Remark	Pol/Phase
	MHz	dBm/m	dBm	dBm/m	dB	dB/m		
1	PP 3470.000	-48.25	-56.83	-13.00	-35.25	8.58	Peak	Horizontal
2	5197.500	-49.53	-58.65	-13.00	-36.53	9.12	Peak	Horizontal

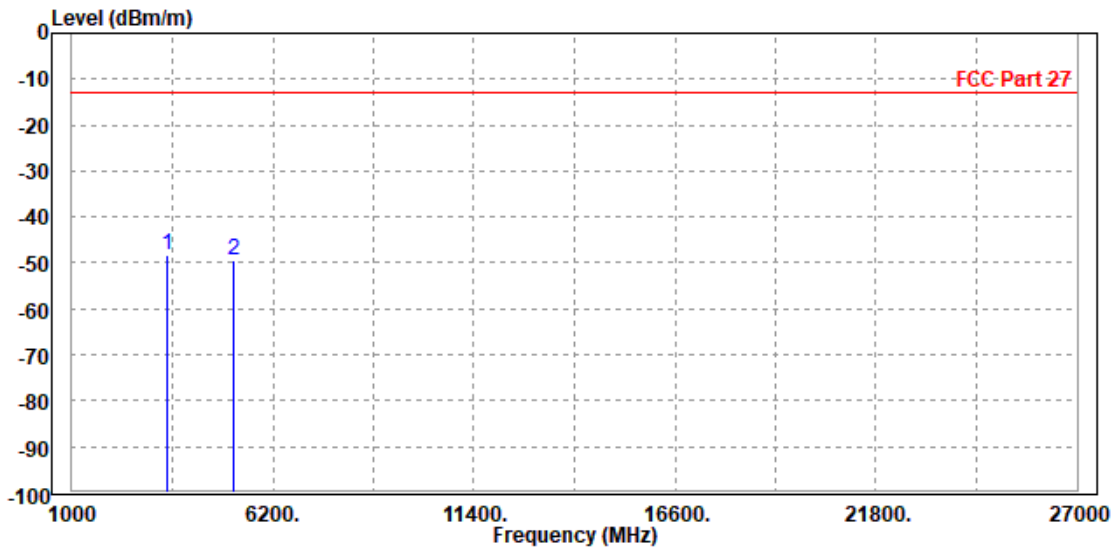



Test Report No.: W7L-P21090022RF06

MODE	TX channel 20175	FREQUENCY RANGE	Above 1000MHz
ENVIRONMENTAL CONDITIONS	23deg. C, 70%RH	INPUT POWER	AC 120V/60Hz
TESTED BY	Jace Hu		
ANTENNA POLARITY & TEST DISTANCE: VERTICAL AT 3 M			

	Freq	Level	Read Level	Limit Line	Over Limit	Factor	Remark	Pol/Phase
	MHz	dBm/m	dBm	dBm/m	dB	dB/m		
1	PP 3470.000	-47.49	-56.65	-13.00	-34.49	9.16	Peak	Vertical
2	5197.500	-48.30	-58.12	-13.00	-35.30	9.82	Peak	Vertical

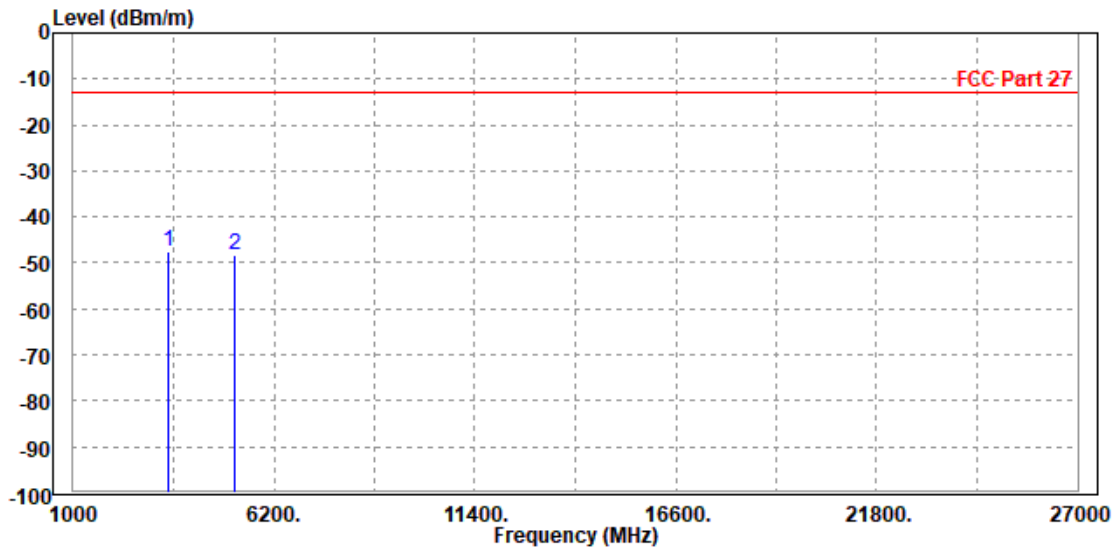



Test Report No.: W7L-P21090022RF06

CHANNEL BANDWIDTH: 20MHz / QPSK
CH 20175

MODE	TX channel 20175	FREQUENCY RANGE	Above 1000MHz
ENVIRONMENTAL CONDITIONS	23deg. C, 70%RH	INPUT POWER	AC 120V/60Hz
TESTED BY	Jace Hu		
ANTENNA POLARITY & TEST DISTANCE: HORIZONTAL AT 3 M			

	Freq	Level	Read Level	Limit Line	Over Limit	Factor	Remark	Pol/Phase
	MHz	dBm/m	dBm	dBm/m	dB	dB/m		
1	PP 3470.000	-46.29	-54.87	-13.00	-33.29	8.58	Peak	Horizontal
2	5197.500	-47.54	-56.66	-13.00	-34.54	9.12	Peak	Horizontal

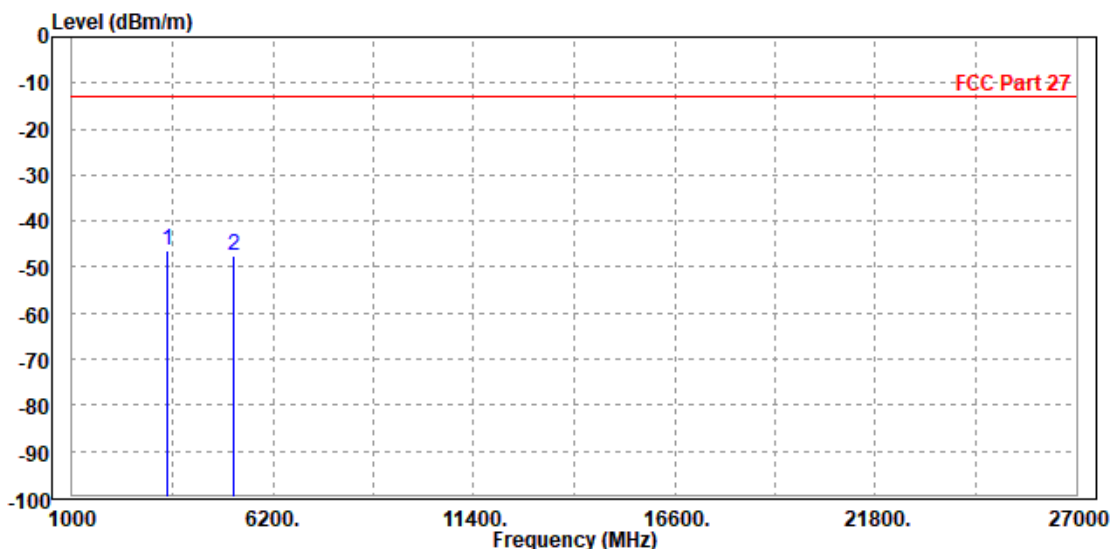



Test Report No.: W7L-P21090022RF06

MODE	TX channel 20175	FREQUENCY RANGE	Above 1000MHz
ENVIRONMENTAL CONDITIONS	23deg. C, 70%RH	INPUT POWER	AC 120V/60Hz
TESTED BY	Jace Hu		
ANTENNA POLARITY & TEST DISTANCE: VERTICAL AT 3 M			

	Freq	Level	Read Level	Limit Line	Over Limit	Factor	Remark	Pol/Phase
	MHz	dBm/m	dBm	dBm/m	dB	dB/m		
1	PP 3470.000	-47.92	-57.08	-13.00	-34.92	9.16	Peak	Vertical
2	5197.500	-48.13	-57.95	-13.00	-35.13	9.82	Peak	Vertical

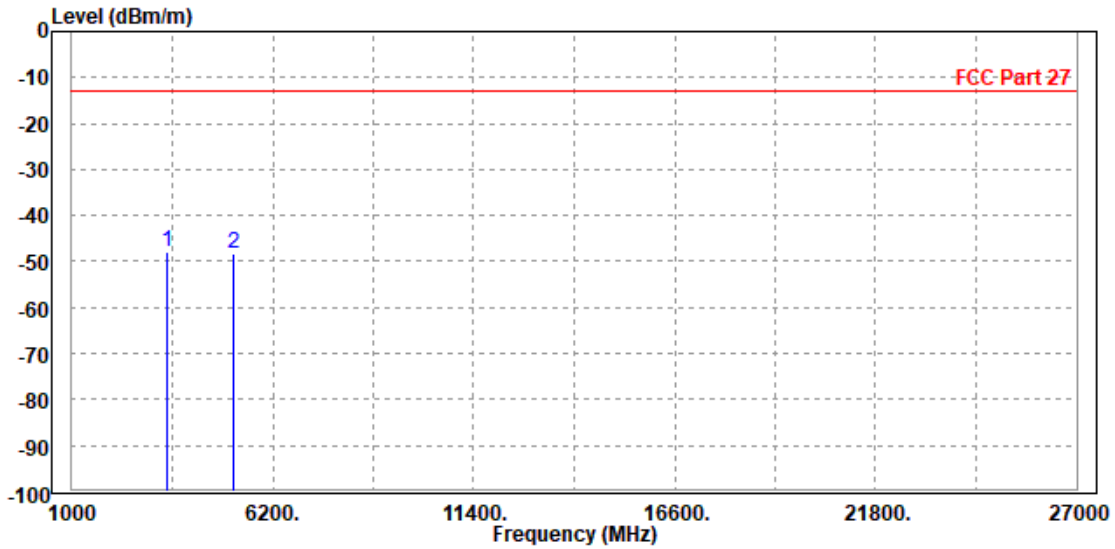



BUREAU VERITAS

Test Report No.: W7L-P21090022RF06

LTE BAND 12

CHANNEL BANDWIDTH: 1.4MHz / QPSK

CH 23017

MODE	TX channel 23017	FREQUENCY RANGE	Above 1000MHz
ENVIRONMENTAL CONDITIONS	23deg. C, 70%RH	INPUT POWER	AC 120V/60Hz
TESTED BY	Jace Hu		
ANTENNA POLARITY & TEST DISTANCE: HORIZONTAL AT 3 M			

	Freq	Level	Read Level	Limit Line	Over Limit	Factor	Remark	Pol/Phase
	MHz	dBm/m	dBm	dBm/m	dB	dB/m		
1	1390.000	-46.26	-47.23	-13.00	-33.26	0.97	Peak	Horizontal
2	PP 2099.100	-38.95	-46.60	-13.00	-25.95	7.65	Peak	Horizontal

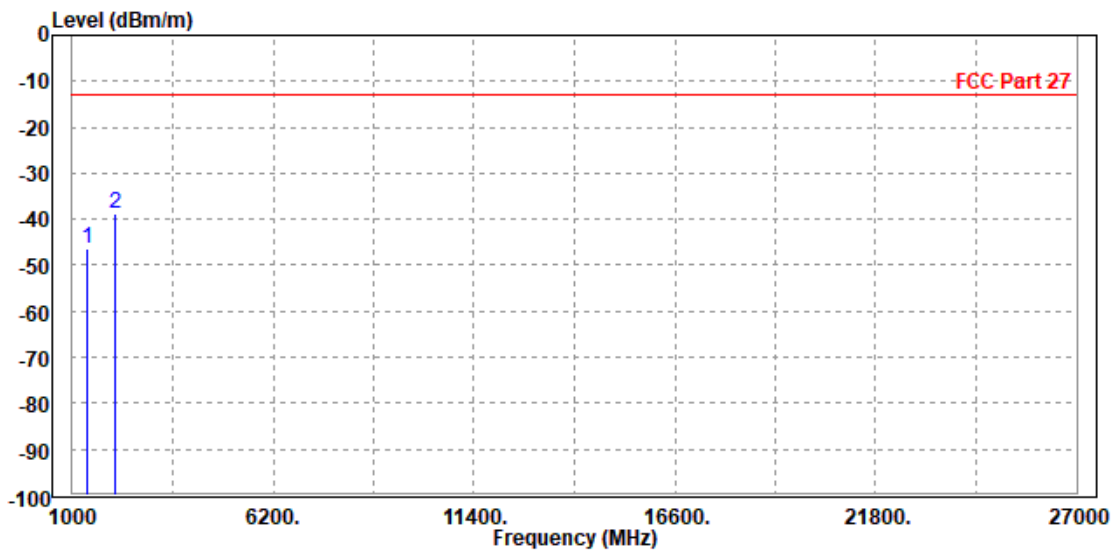



Test Report No.: W7L-P21090022RF06

MODE	TX channel 23017	FREQUENCY RANGE	Above 1000MHz
ENVIRONMENTAL CONDITIONS	23deg. C, 70%RH	INPUT POWER	AC 120V/60Hz
TESTED BY	Jace Hu		
ANTENNA POLARITY & TEST DISTANCE: VERTICAL AT 3 M			

	Freq	Level	Read Level	Limit Line	Over Limit	Factor	Remark	Pol/Phase
	MHz	dBm/m	dBm	dBm/m	dB	dB/m		
1	PP 1390.000	-44.26	-45.84	-13.00	-31.26	1.58	Peak	Vertical
2	2099.100	-45.66	-52.32	-13.00	-32.66	6.66	Peak	Vertical

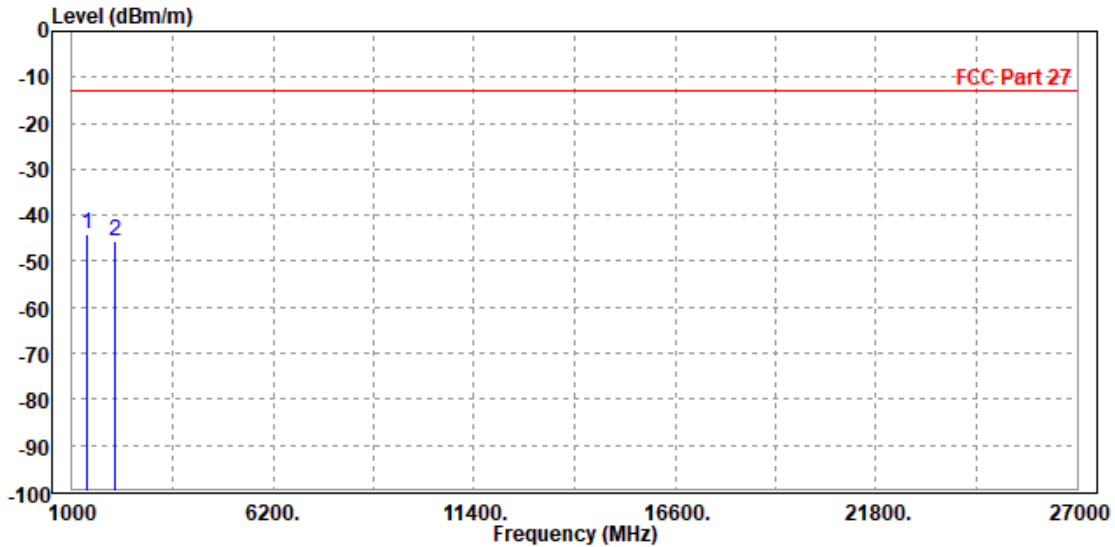



Test Report No.: W7L-P21090022RF06

CH 23095

MODE	TX channel 23095	FREQUENCY RANGE	Above 1000MHz
ENVIRONMENTAL CONDITIONS	23deg. C, 70%RH	INPUT POWER	AC 120V/60Hz
TESTED BY	Jace Hu		
ANTENNA POLARITY & TEST DISTANCE: HORIZONTAL AT 3 M			

	Freq	Level	Read Level	Limit Line	Over Limit	Factor	Remark	Pol/Phase
	MHz	dBm/m	dBm	dBm/m	dB	dB/m		
1	PP 1416.000	-40.32	-41.40	-13.00	-27.32	1.08	Peak	Horizontal
2	2122.500	-40.92	-48.59	-13.00	-27.92	7.67	Peak	Horizontal

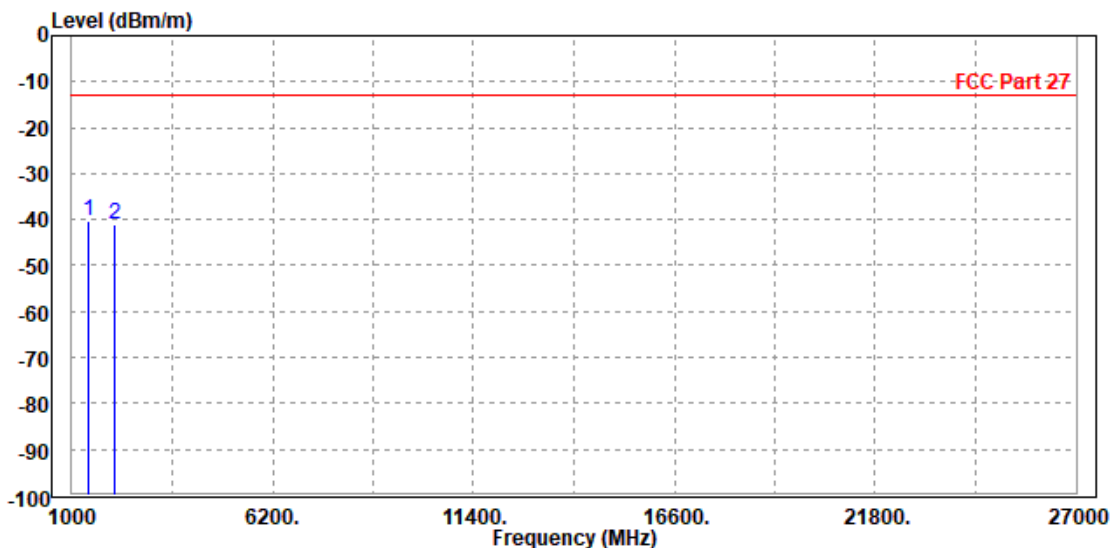



Test Report No.: W7L-P21090022RF06

MODE	TX channel 23095	FREQUENCY RANGE	Above 1000MHz
ENVIRONMENTAL CONDITIONS	23deg. C, 70%RH	INPUT POWER	AC 120V/60Hz
TESTED BY	Jace Hu		
ANTENNA POLARITY & TEST DISTANCE: VERTICAL AT 3 M			

	Freq	Level	Read Level	Limit Line	Over Limit	Factor	Remark	Pol/Phase
	MHz	dBm/m	dBm	dBm/m	dB	dB/m		
1	PP 1416.000	-37.76	-39.45	-13.00	-24.76	1.69	Peak	Vertical
2	2122.500	-41.83	-48.52	-13.00	-28.83	6.69	Peak	Vertical

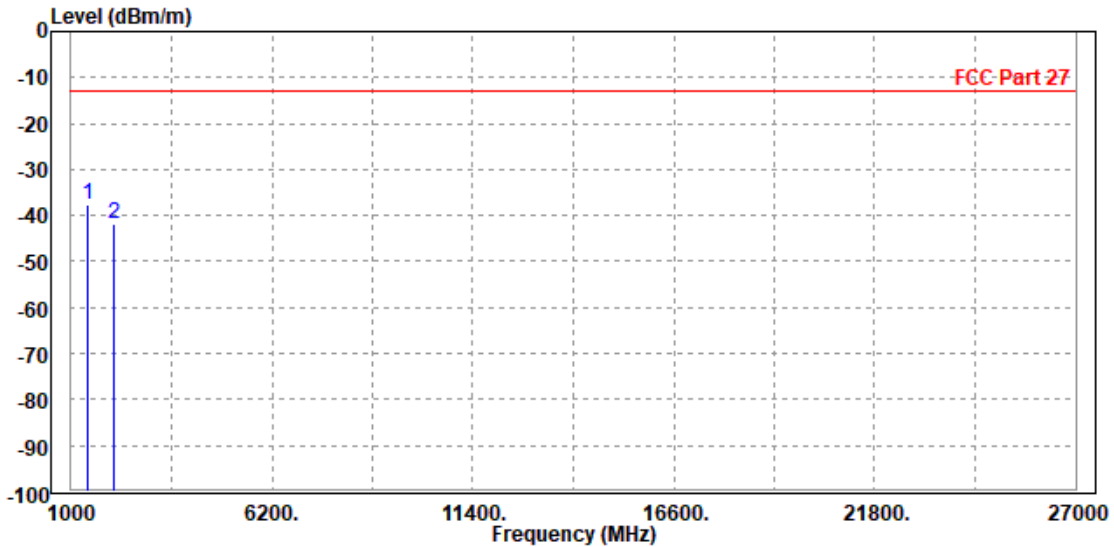



**BUREAU
VERITAS**

Test Report No.: W7L-P21090022RF06

CH 23173

MODE	TX channel 23173	FREQUENCY RANGE	Above 1000MHz
ENVIRONMENTAL CONDITIONS	23deg. C, 70%RH	INPUT POWER	AC 120V/60Hz
TESTED BY	Jace Hu		
ANTENNA POLARITY & TEST DISTANCE: HORIZONTAL AT 3 M			

	Freq	Level	Read Level	Limit Line	Over Limit	Factor	Remark	Pol/Phase
	MHz	dBm/m	dBm	dBm/m	dB	dB/m		
1	1442.000	-41.95	-43.14	-13.00	-28.95	1.19	Peak	Horizontal
2 PP	2145.900	-38.30	-45.99	-13.00	-25.30	7.69	Peak	Horizontal

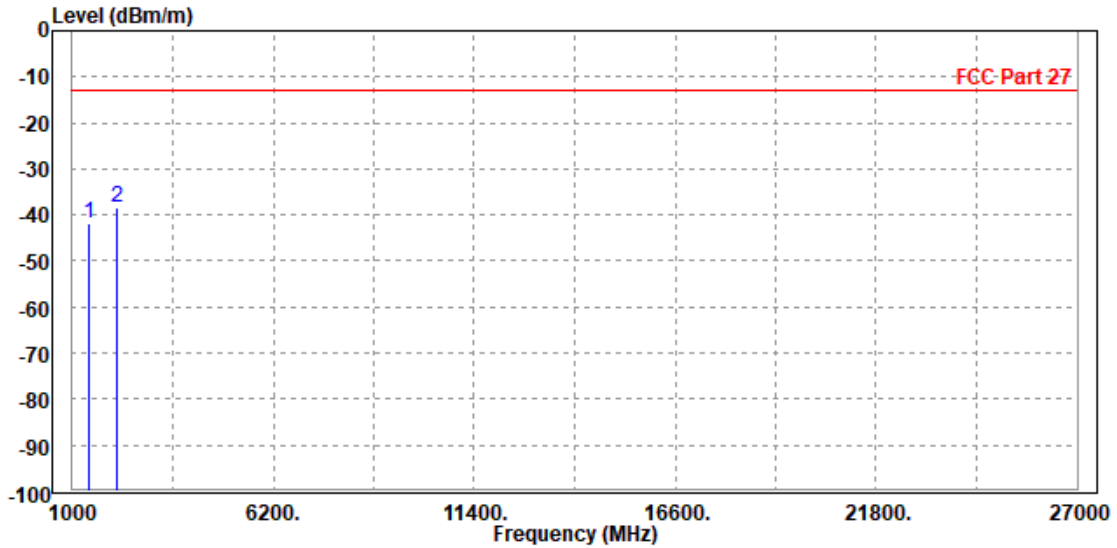



Test Report No.: W7L-P21090022RF06

MODE	TX channel 23173	FREQUENCY RANGE	Above 1000MHz
ENVIRONMENTAL CONDITIONS	23deg. C, 70%RH	INPUT POWER	AC 120V/60Hz
TESTED BY	Jace Hu		
ANTENNA POLARITY & TEST DISTANCE: VERTICAL AT 3 M			

	Freq	Level	Read Level	Limit Line	Over Limit	Factor	Remark	Pol/Phase
	MHz	dBm/m	dBm	dBm/m	dB	dB/m		
1	PP 1442.000	-40.91	-42.71	-13.00	-27.91	1.80	Peak	Vertical
2	2145.900	-42.55	-49.26	-13.00	-29.55	6.71	Peak	Vertical

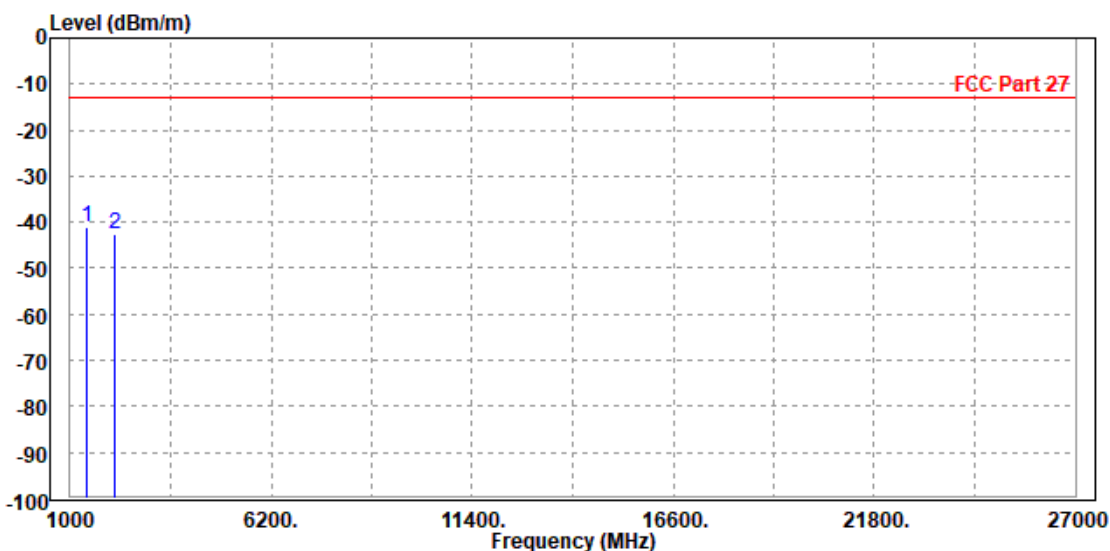



BUREAU VERITAS

Test Report No.: W7L-P21090022RF06

CHANNEL BANDWIDTH: 3MHz / QPSK

MODE	TX channel 23095	FREQUENCY RANGE	Above 1000MHz
ENVIRONMENTAL CONDITIONS	23deg. C, 70%RH	INPUT POWER	AC 120V/60Hz
TESTED BY	Jace Hu		
ANTENNA POLARITY & TEST DISTANCE: HORIZONTAL AT 3 M			

	Freq	Level	Read Level	Limit Line	Over Limit	Factor	Remark	Pol/Phase
	MHz	dBm/m	dBm	dBm/m	dB	dB/m		
1	1416.000	-43.33	-44.41	-13.00	-30.33	1.08	Peak	Horizontal
2	PP 2122.500	-42.52	-50.19	-13.00	-29.52	7.67	Peak	Horizontal

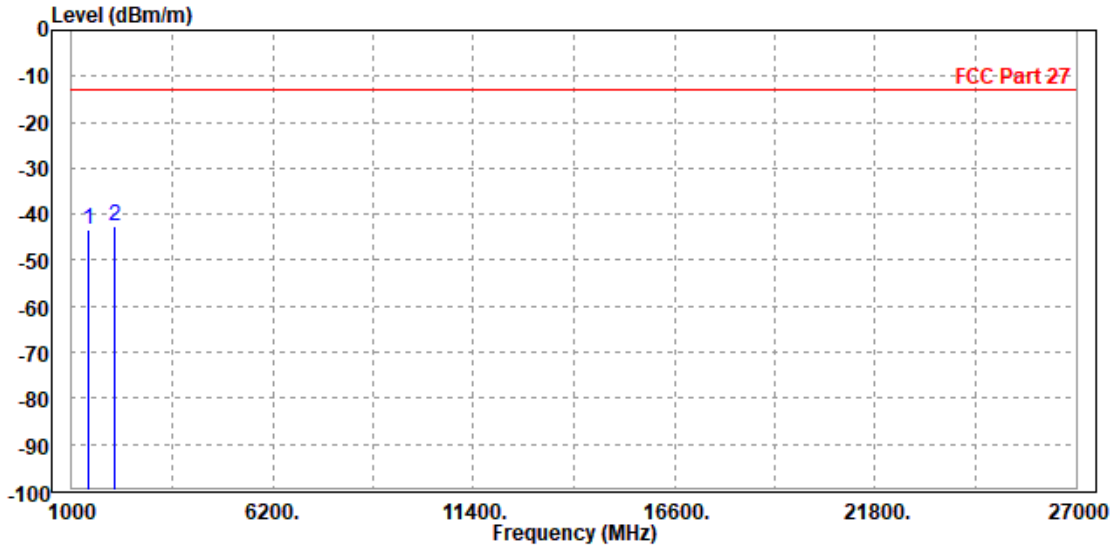



Test Report No.: W7L-P21090022RF06

MODE	TX channel 23095	FREQUENCY RANGE	Above 1000MHz
ENVIRONMENTAL CONDITIONS	23deg. C, 70%RH	INPUT POWER	AC 120V/60Hz
TESTED BY	Jace Hu		
ANTENNA POLARITY & TEST DISTANCE: VERTICAL AT 3 M			

	Freq	Level	Read Level	Limit Line	Over Limit	Factor	Remark	Pol/Phase
	MHz	dBm/m	dBm	dBm/m	dB	dB/m		
1	PP 1416.000	-40.49	-42.18	-13.00	-27.49	1.69	Peak	Vertical
2	2122.500	-45.46	-52.15	-13.00	-32.46	6.69	Peak	Vertical

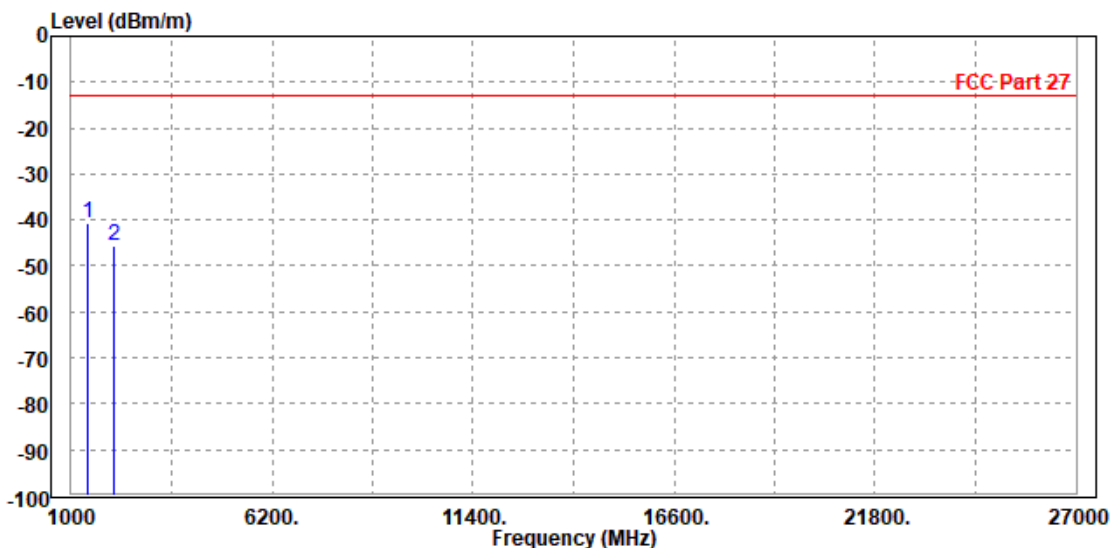



Test Report No.: W7L-P21090022RF06

CHANNEL BANDWIDTH: 5MHz / QPSK

MODE	TX channel 23095	FREQUENCY RANGE	Above 1000MHz
ENVIRONMENTAL CONDITIONS	23deg. C, 70%RH	INPUT POWER	AC 120V/60Hz
TESTED BY	Jace Hu		
ANTENNA POLARITY & TEST DISTANCE: HORIZONTAL AT 3 M			

	Freq	Level	Read Level	Limit Line	Over Limit	Factor	Remark	Pol/Phase
	MHz	dBm/m	dBm	dBm/m	dB	dB/m		
1	1416.000	-45.40	-46.48	-13.00	-32.40	1.08	Peak	Horizontal
2 PP	2122.500	-42.26	-49.93	-13.00	-29.26	7.67	Peak	Horizontal

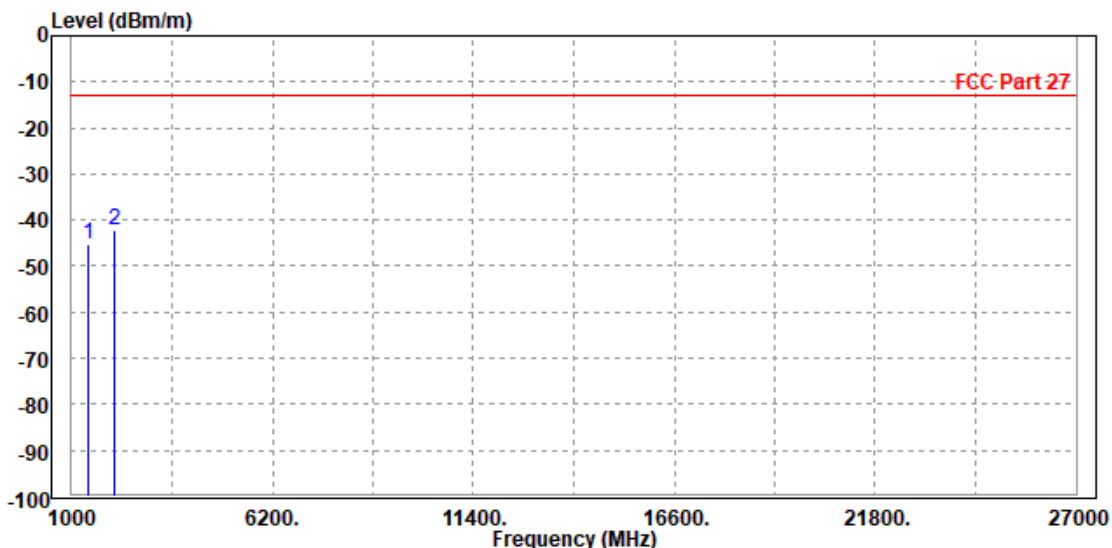



Test Report No.: W7L-P21090022RF06

MODE	TX channel 23095	FREQUENCY RANGE	Above 1000MHz
ENVIRONMENTAL CONDITIONS	23deg. C, 70%RH	INPUT POWER	AC 120V/60Hz
TESTED BY	Jace Hu		
ANTENNA POLARITY & TEST DISTANCE: VERTICAL AT 3 M			

	Freq	Level	Read Level	Limit Line	Over Limit	Factor	Remark	Pol/Phase
	MHz	dBm/m	dBm	dBm/m	dB	dB/m		
1 PP	1416.000	-42.73	-44.42	-13.00	-29.73	1.69	Peak	Vertical
2	2122.500	-44.71	-51.40	-13.00	-31.71	6.69	Peak	Vertical

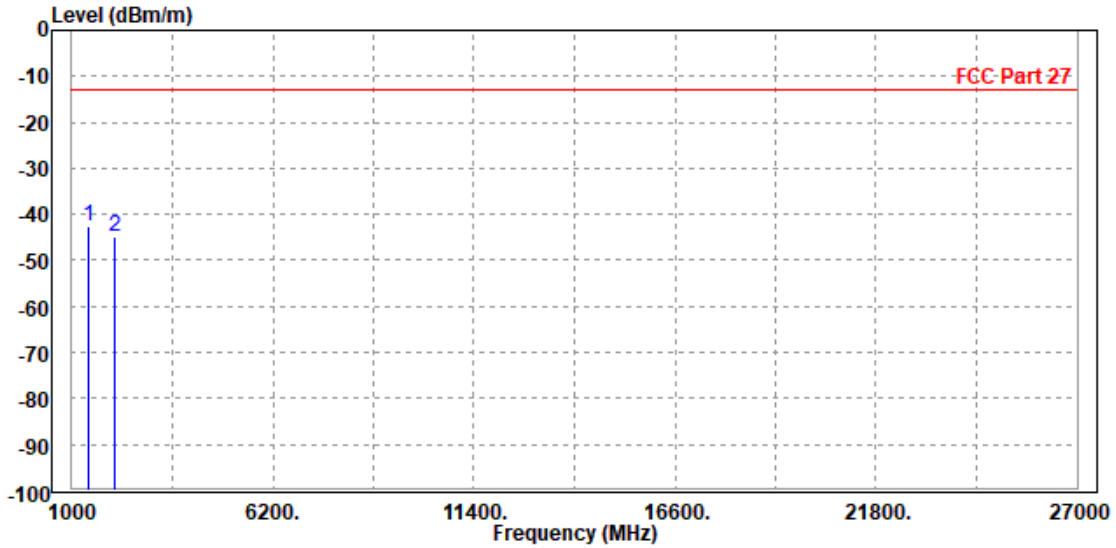



Test Report No.: W7L-P21090022RF06

CHANNEL BANDWIDTH: 10MHz / QPSK

CH23095

MODE	TX channel 23095	FREQUENCY RANGE	Above 1000MHz
ENVIRONMENTAL CONDITIONS	23deg. C, 70%RH	INPUT POWER	AC 120V/60Hz
TESTED BY	Jace Hu		
ANTENNA POLARITY & TEST DISTANCE: HORIZONTAL AT 3 M			

	Freq	Level	Read Level	Limit Line	Over Limit	Factor	Remark	Pol/Phase
	MHz	dBm/m	dBm	dBm/m	dB	dB/m		
1	1416.000	-45.41	-46.49	-13.00	-32.41	1.08	Peak	Horizontal
2 PP	2122.500	-43.53	-51.20	-13.00	-30.53	7.67	Peak	Horizontal

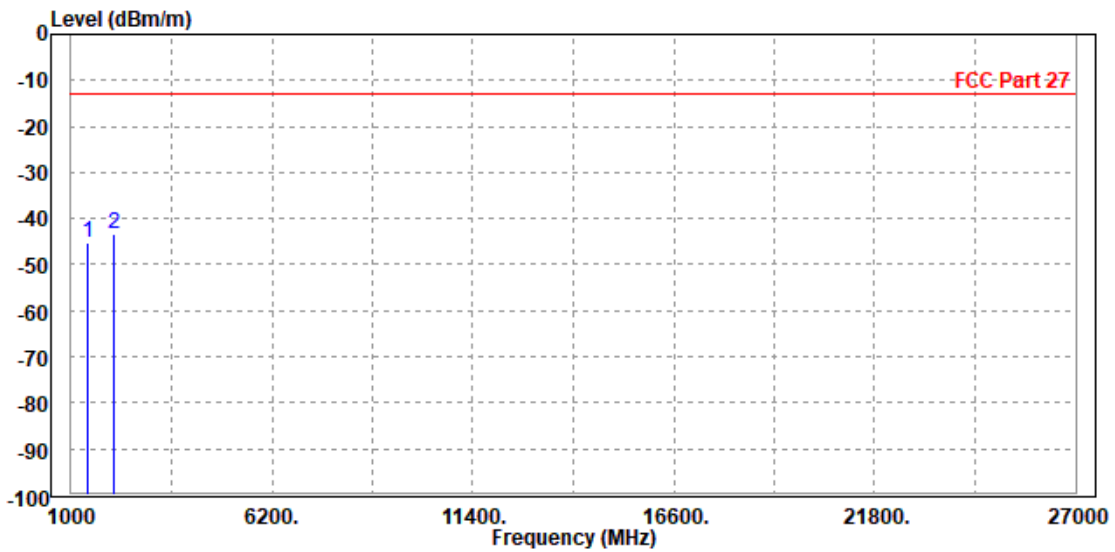



Test Report No.: W7L-P21090022RF06

MODE	TX channel 23095	FREQUENCY RANGE	Above 1000MHz
ENVIRONMENTAL CONDITIONS	23deg. C, 70%RH	INPUT POWER	AC 120V/60Hz
TESTED BY	Jace Hu		
ANTENNA POLARITY & TEST DISTANCE: VERTICAL AT 3 M			

	Freq	Level	Read Level	Limit Line	Over Limit	Factor	Remark	Pol/Phase
	MHz	dBm/m	dBm	dBm/m	dB	dB/m		
1	1416.000	-45.88	-47.57	-13.00	-32.88	1.69	Peak	Vertical
2	PP 2122.500	-45.28	-51.97	-13.00	-32.28	6.69	Peak	Vertical

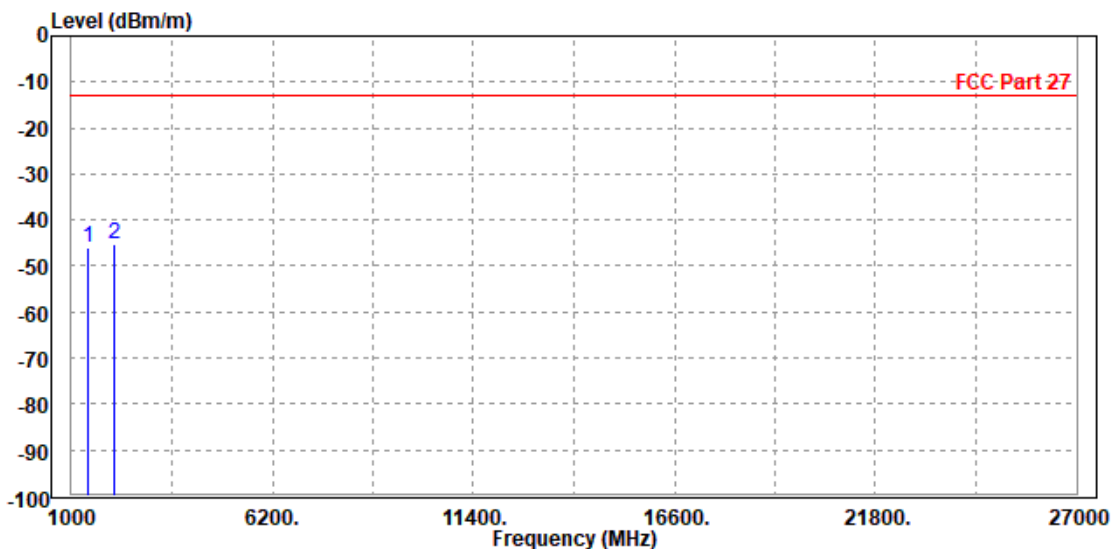



Test Report No.: W7L-P21090022RF06

LTE B13

CHANNEL BANDWIDTH: 5MHz / QPSK

CH23205

MODE	TX channel 23205	FREQUENCY RANGE	Above 1000MHz
ENVIRONMENTAL CONDITIONS	23deg. C, 70%RH	INPUT POWER	AC 120V/60Hz
TESTED BY	Jace Hu		
ANTENNA POLARITY & TEST DISTANCE: HORIZONTAL AT 3 M			

	Freq	Level	Read Level	Limit Line	Over Limit	Factor	Remark	Pol/Phase
	MHz	dBm/m	dBm	dBm/m	dB	dB/m		
1	PP 1572.000	-54.59	-56.91	-40.00	-14.59	2.32	Peak	Horizontal
2	2326.000	-32.92	-40.79	-13.00	-19.92	7.87	Peak	Horizontal

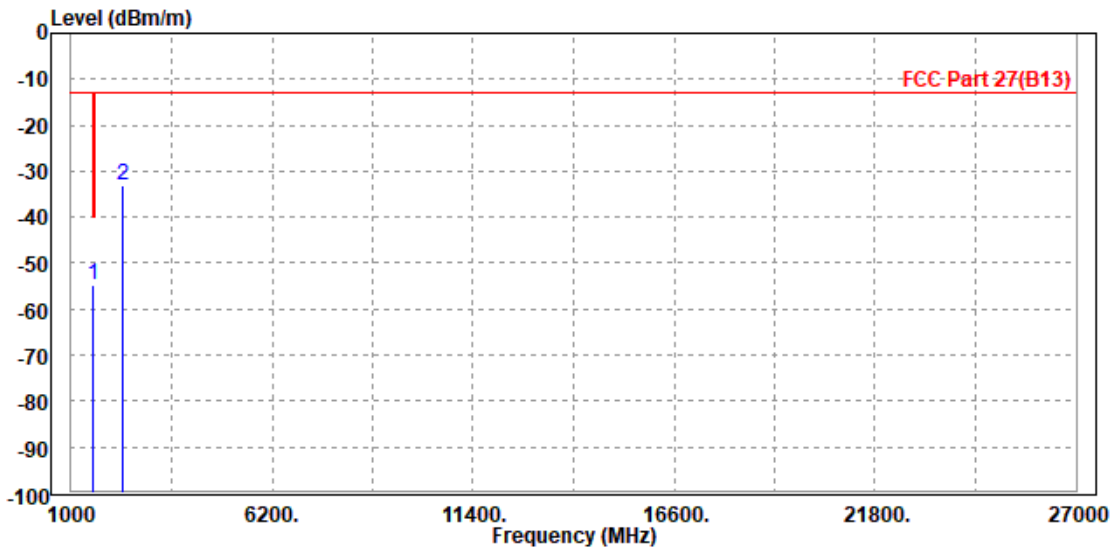



Test Report No.: W7L-P21090022RF06

MODE	TX channel 23205	FREQUENCY RANGE	Above 1000MHz
ENVIRONMENTAL CONDITIONS	23deg. C, 70%RH	INPUT POWER	AC 120V/60Hz
TESTED BY	Jace Hu		
ANTENNA POLARITY & TEST DISTANCE: VERTICAL AT 3 M			

	Freq	Level	Read Level	Limit Line	Over Limit	Factor	Remark	Pol/Phase
	MHz	dBm/m	dBm	dBm/m	dB	dB/m		
1	PP 1559.000	-52.54	-55.12	-40.00	-12.54	2.58	Peak	Vertical
2	2326.000	-31.37	-38.26	-13.00	-18.37	6.89	Peak	Vertical

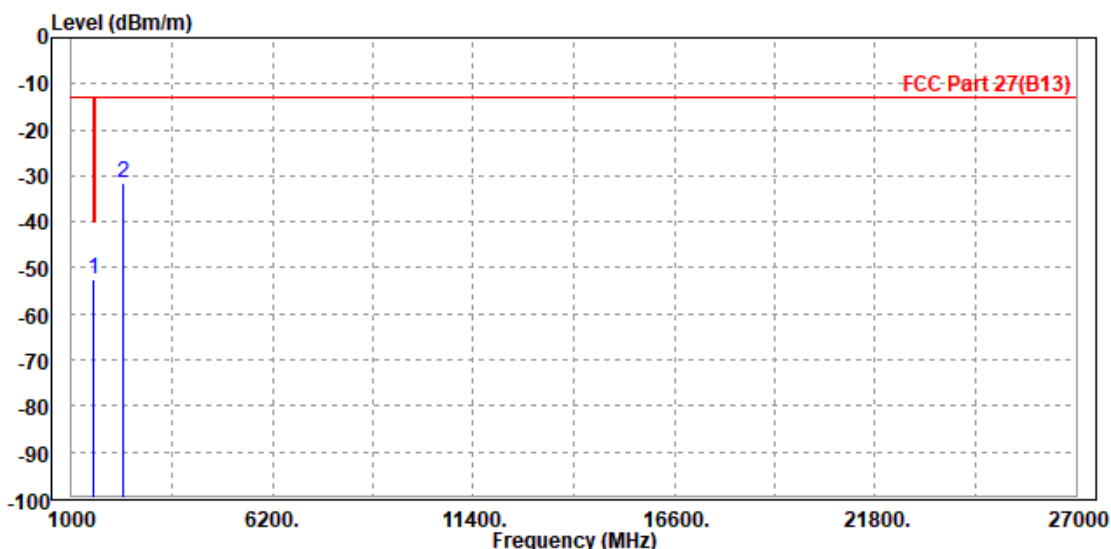



Test Report No.: W7L-P21090022RF06

CH23230

MODE	TX channel 23230	FREQUENCY RANGE	Above 1000MHz
ENVIRONMENTAL CONDITIONS	23deg. C, 70%RH	INPUT POWER	AC 120V/60Hz
TESTED BY	Jace Hu		
ANTENNA POLARITY & TEST DISTANCE: HORIZONTAL AT 3 M			

	Freq	Level	Read Level	Limit Line	Over Limit	Factor	Remark	Pol/Phase
	MHz	dBm/m	dBm	dBm/m	dB	dB/m		
1	PP 1564.000	-52.71	-54.94	-40.00	-12.71	2.23	Peak	Horizontal
2	2352.000	-38.70	-46.60	-13.00	-25.70	7.90	Peak	Horizontal

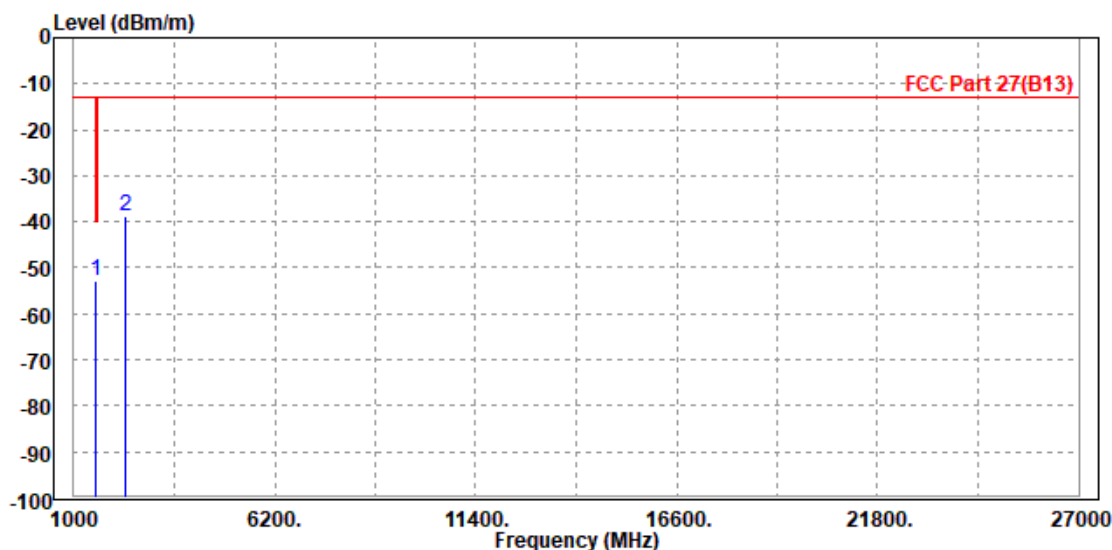



Test Report No.: W7L-P21090022RF06

MODE	TX channel 23230	FREQUENCY RANGE	Above 1000MHz
ENVIRONMENTAL CONDITIONS	23deg. C, 70%RH	INPUT POWER	AC 120V/60Hz
TESTED BY	Jace Hu		
ANTENNA POLARITY & TEST DISTANCE: VERTICAL AT 3 M			

	Freq	Level	Read Level	Limit Line	Over Limit	Factor	Remark	Pol/Phase
	MHz	dBm/m	dBm	dBm/m	dB	dB/m		
1	PP 1572.000	-53.27	-55.97	-40.00	-13.27	2.70	Peak	Vertical
2	2346.000	-43.74	-50.65	-13.00	-30.74	6.91	Peak	Vertical

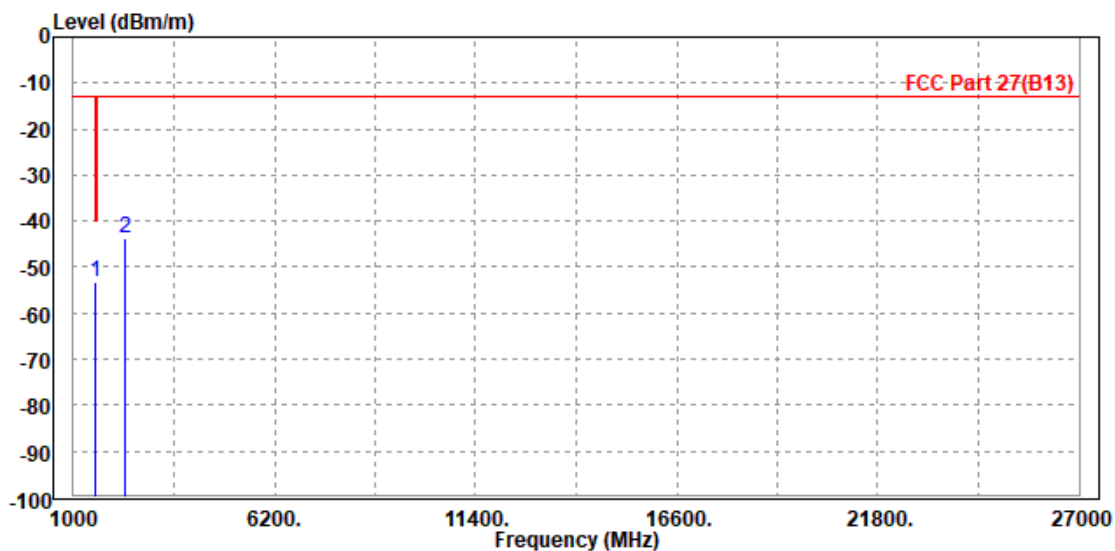



Test Report No.: W7L-P21090022RF06

CH23255

MODE	TX channel 23255	FREQUENCY RANGE	Above 1000MHz
ENVIRONMENTAL CONDITIONS	23deg. C, 70%RH	INPUT POWER	AC 120V/60Hz
TESTED BY	Jace Hu		
ANTENNA POLARITY & TEST DISTANCE: HORIZONTAL AT 3 M			

	Freq	Level	Read Level	Limit Line	Over Limit	Factor	Remark	Pol/Phase
	MHz	dBm/m	dBm	dBm/m	dB	dB/m		
1	PP 1569.000	-52.29	-54.58	-40.00	-12.29	2.29	Peak	Horizontal
2	2352.000	-38.86	-46.76	-13.00	-25.86	7.90	Peak	Horizontal

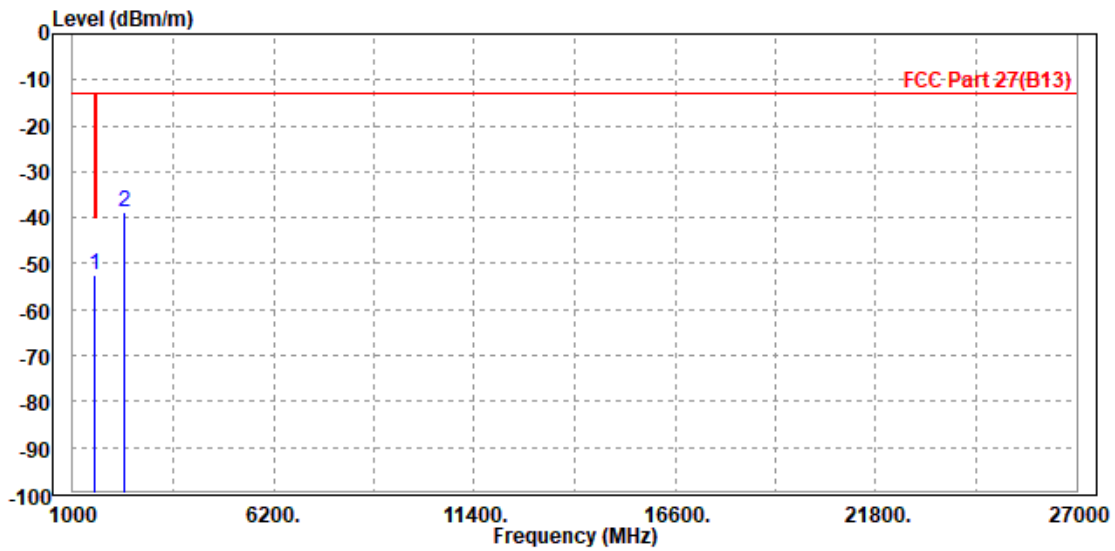



Test Report No.: W7L-P21090022RF06

MODE	TX channel 23255	FREQUENCY RANGE	Above 1000MHz
ENVIRONMENTAL CONDITIONS	23deg. C, 70%RH	INPUT POWER	AC 120V/60Hz
TESTED BY	Jace Hu		
ANTENNA POLARITY & TEST DISTANCE: VERTICAL AT 3 M			

	Freq	Level	Read Level	Limit Line	Over Limit	Factor	Remark	Pol/Phase
	MHz	dBm/m	dBm	dBm/m	dB	dB/m		
1	PP 1572.000	-53.46	-56.16	-40.00	-13.46	2.70	Peak	Vertical
2	2353.500	-39.45	-46.37	-13.00	-26.45	6.92	Peak	Vertical

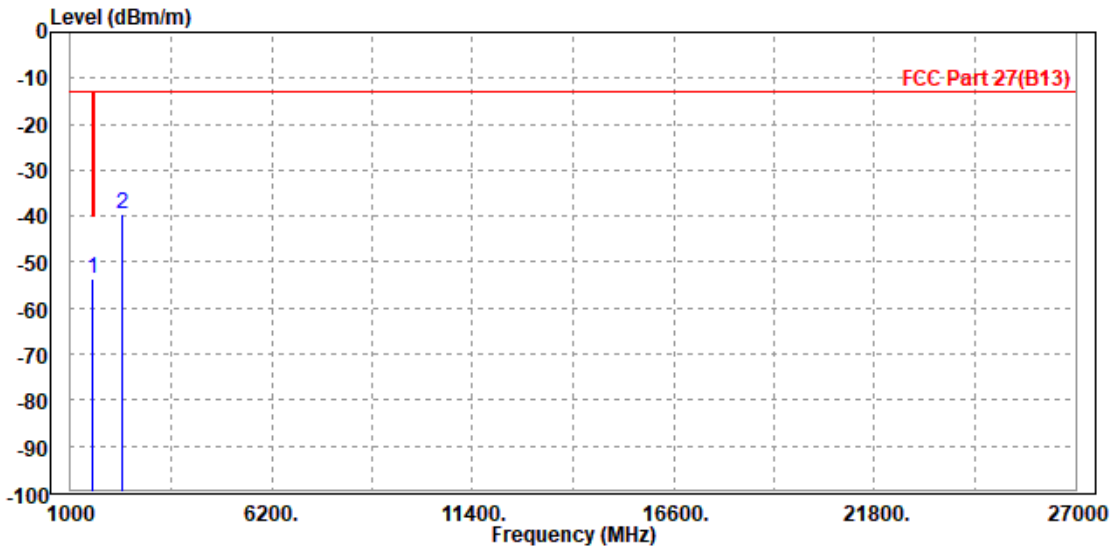



Test Report No.: W7L-P21090022RF06

CHANNEL BANDWIDTH: 10MHz /QPSK

MODE	TX channel 23230	FREQUENCY RANGE	Above 1000MHz
ENVIRONMENTAL CONDITIONS	23deg. C, 70%RH	INPUT POWER	AC 120V/60Hz
TESTED BY	Jace Hu		
ANTENNA POLARITY & TEST DISTANCE: HORIZONTAL AT 3 M			

	Freq	Level	Read Level	Limit Line	Over Limit	Factor	Remark	Pol/Phase
	MHz	dBm/m	dBm	dBm/m	dB	dB/m		
1	PP 1572.000	-50.79	-53.11	-40.00	-10.79	2.32	Peak	Horizontal
2	2352.000	-37.35	-45.25	-13.00	-24.35	7.90	Peak	Horizontal

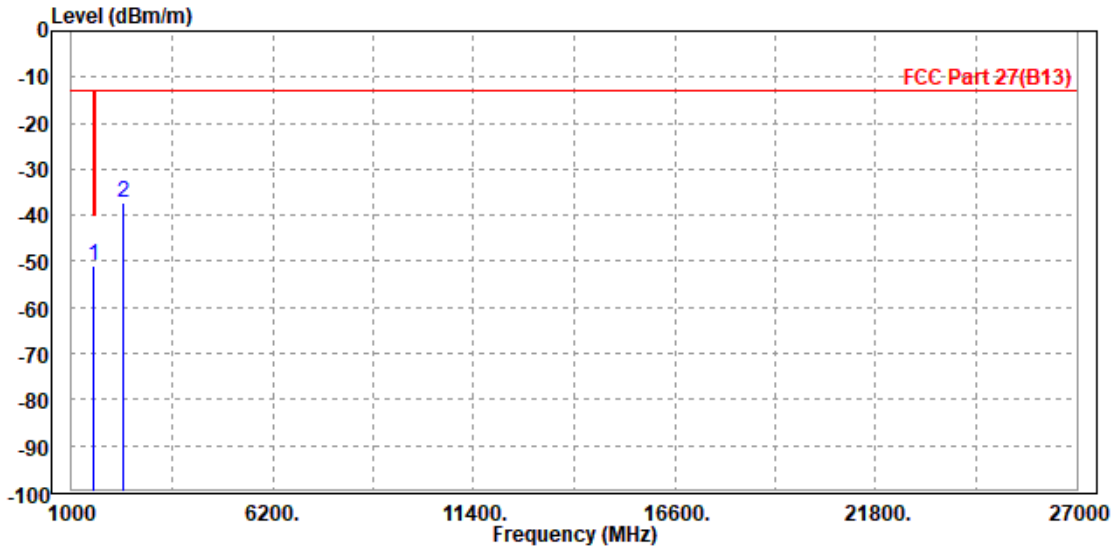



Test Report No.: W7L-P21090022RF06

MODE	TX channel 23230	FREQUENCY RANGE	Above 1000MHz
ENVIRONMENTAL CONDITIONS	23deg. C, 70%RH	INPUT POWER	AC 120V/60Hz
TESTED BY	Jace Hu		
ANTENNA POLARITY & TEST DISTANCE: VERTICAL AT 3 M			

	Freq	Level	Read Level	Limit Line	Over Limit	Factor	Remark	Pol/Phase
	MHz	dBm/m	dBm	dBm/m	dB	dB/m		
1	PP 1564.000	-50.42	-53.04	-40.00	-10.42	2.62	Peak	Vertical
2	2352.000	-33.33	-40.25	-13.00	-20.33	6.92	Peak	Vertical

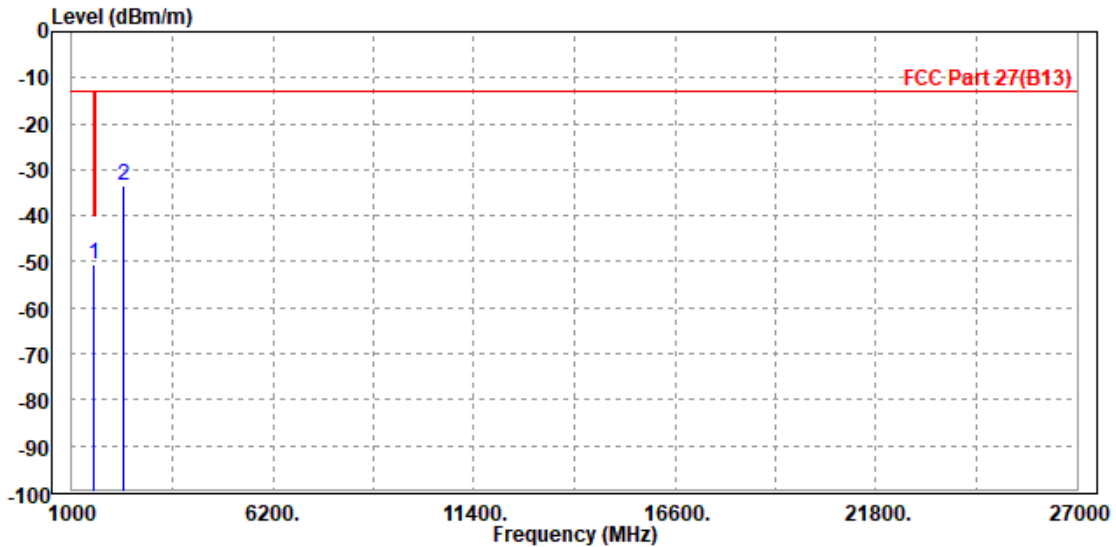



Test Report No.: W7L-P21090022RF06

LTE B17

CHANNEL BANDWIDTH: 5MHz / QPSK

MODE	TX channel 23790	FREQUENCY RANGE	Above 1000MHz
ENVIRONMENTAL CONDITIONS	23deg. C, 70%RH	INPUT POWER	AC 120V/60Hz
TESTED BY	Jace Hu		
ANTENNA POLARITY & TEST DISTANCE: HORIZONTAL AT 3 M			

	Freq	Level	Read Level	Limit Line	Over Limit	Factor	Remark	Pol/Phase
	MHz	dBm/m	dBm	dBm/m	dB	dB/m		
1	1416.000	-44.49	-45.57	-13.00	-31.49	1.08	Peak	Horizontal
2 PP	2130.000	-40.29	-47.97	-13.00	-27.29	7.68	Peak	Horizontal

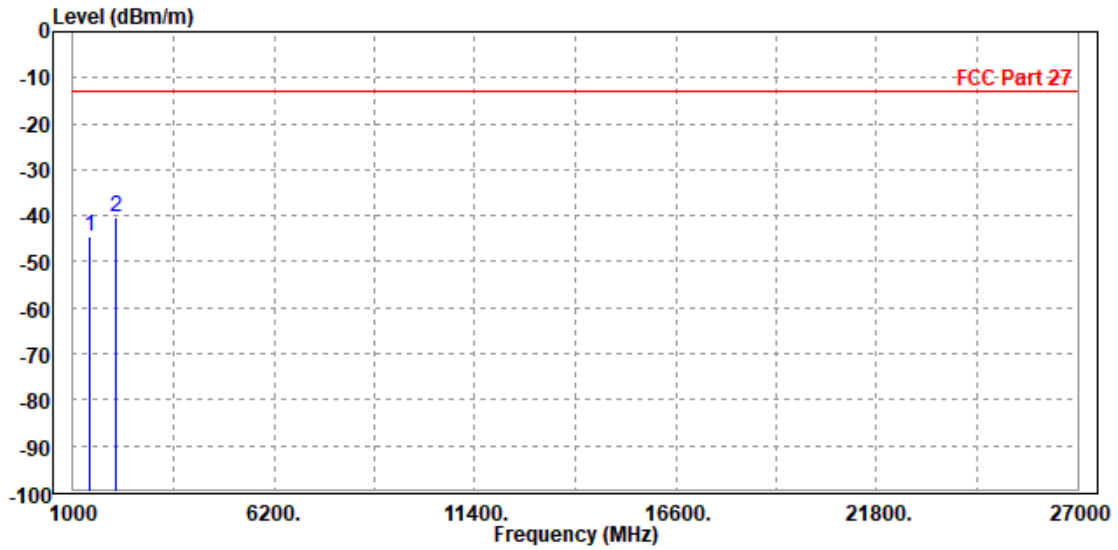



Test Report No.: W7L-P21090022RF06

MODE	TX channel 23790	FREQUENCY RANGE	Above 1000MHz
ENVIRONMENTAL CONDITIONS	23deg. C, 70%RH	INPUT POWER	AC 120V/60Hz
TESTED BY	Jace Hu		
ANTENNA POLARITY & TEST DISTANCE: VERTICAL AT 3 M			

	Freq	Level	Read Level	Limit Line	Over Limit	Factor	Remark	Pol/Phase
	MHz	dBm/m	dBm	dBm/m	dB	dB/m		
1	1416.000	-45.44	-47.13	-13.00	-32.44	1.69	Peak	Vertical
2 PP	2130.000	-41.86	-48.56	-13.00	-28.86	6.70	Peak	Vertical

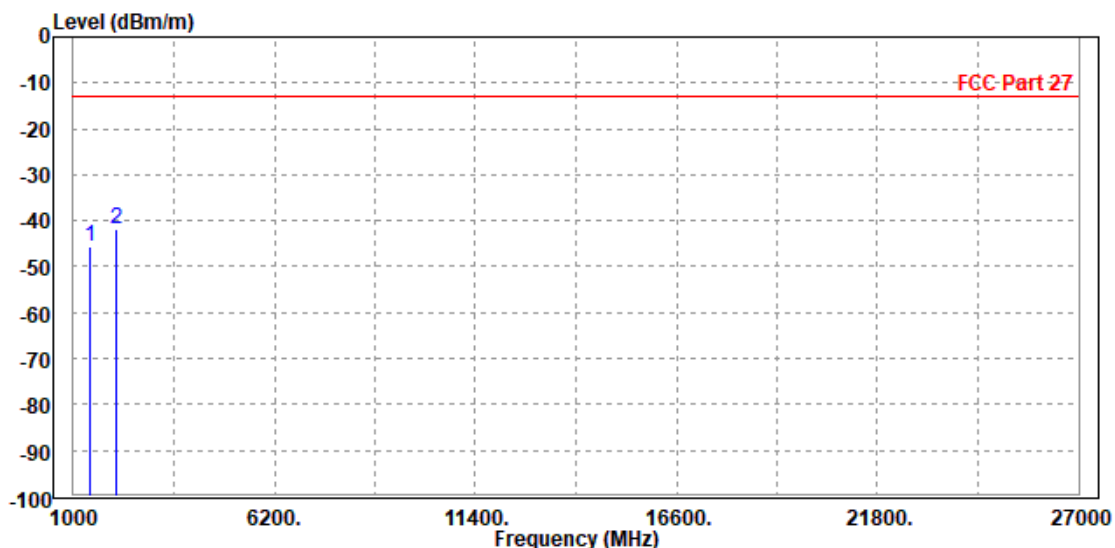



Test Report No.: W7L-P21090022RF06

CHANNEL BANDWIDTH: 10MHz / QPSK

CH23780

MODE	TX channel 23780	FREQUENCY RANGE	Above 1000MHz
ENVIRONMENTAL CONDITIONS	23deg. C, 70%RH	INPUT POWER	AC 120V/60Hz
TESTED BY	Jace Hu		
ANTENNA POLARITY & TEST DISTANCE: HORIZONTAL AT 3 M			

	Freq	Level	Read Level	Limit Line	Over Limit	Factor	Remark	Pol/Phase
	MHz	dBm/m	dBm	dBm/m	dB	dB/m		
1	1416.000	-48.52	-49.60	-13.00	-35.52	1.08	Peak	Horizontal
2	PP 2127.000	-39.45	-47.12	-13.00	-26.45	7.67	Peak	Horizontal

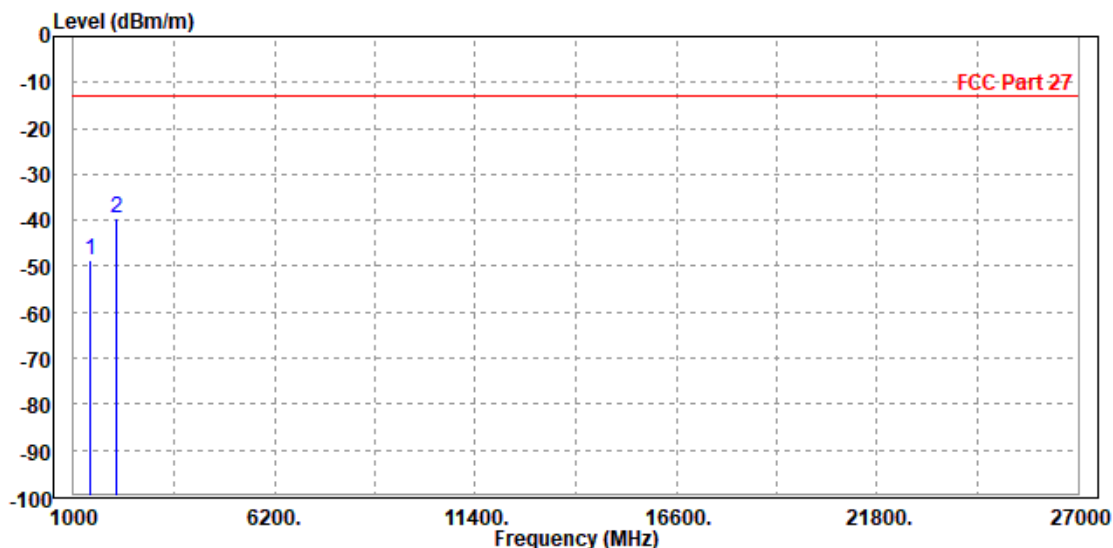



Test Report No.: W7L-P21090022RF06

MODE	TX channel 23780	FREQUENCY RANGE	Above 1000MHz
ENVIRONMENTAL CONDITIONS	23deg. C, 70%RH	INPUT POWER	AC 120V/60Hz
TESTED BY	Jace Hu		
ANTENNA POLARITY & TEST DISTANCE: VERTICAL AT 3 M			

	Freq	Level	Read Level	Limit Line	Over Limit	Factor	Remark	Pol/Phase
	MHz	dBm/m	dBm	dBm/m	dB	dB/m		
1	1416.000	-46.17	-47.86	-13.00	-33.17	1.69	Peak	Vertical
2	PP 2127.000	-42.76	-49.45	-13.00	-29.76	6.69	Peak	Vertical

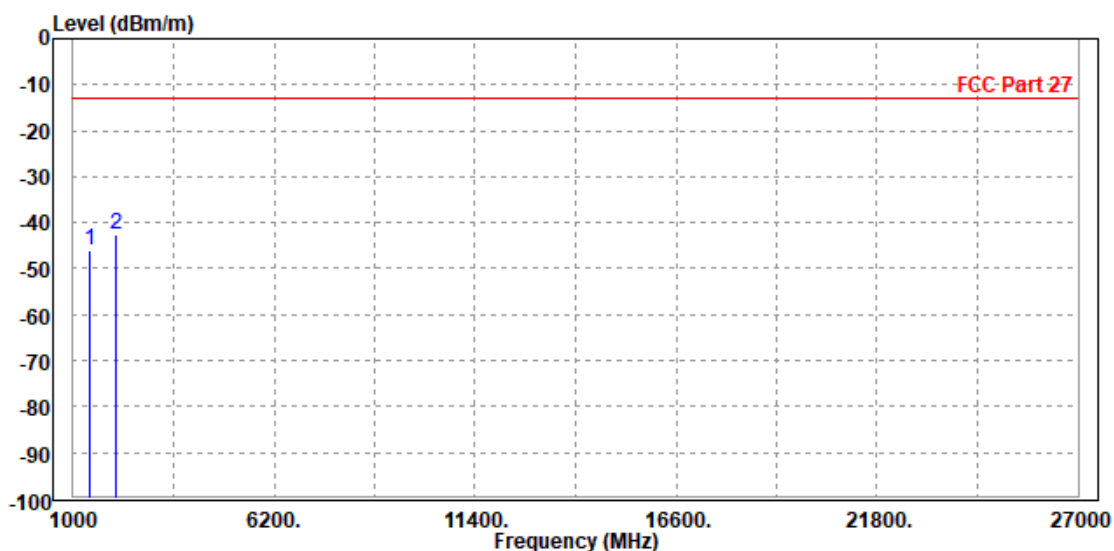



Test Report No.: W7L-P21090022RF06

CH23790

MODE	TX channel 23790	FREQUENCY RANGE	Above 1000MHz
ENVIRONMENTAL CONDITIONS	23deg. C, 70%RH	INPUT POWER	AC 120V/60Hz
TESTED BY	Jace Hu		
ANTENNA POLARITY & TEST DISTANCE: HORIZONTAL AT 3 M			

	Freq	Level	Read Level	Limit Line	Over Limit	Factor	Remark	Pol/Phase
	MHz	dBm/m	dBm	dBm/m	dB	dB/m		
1	1416.000	-40.06	-41.14	-13.00	-27.06	1.08	Peak	Horizontal
2	PP 2130.000	-31.25	-38.93	-13.00	-18.25	7.68	Peak	Horizontal

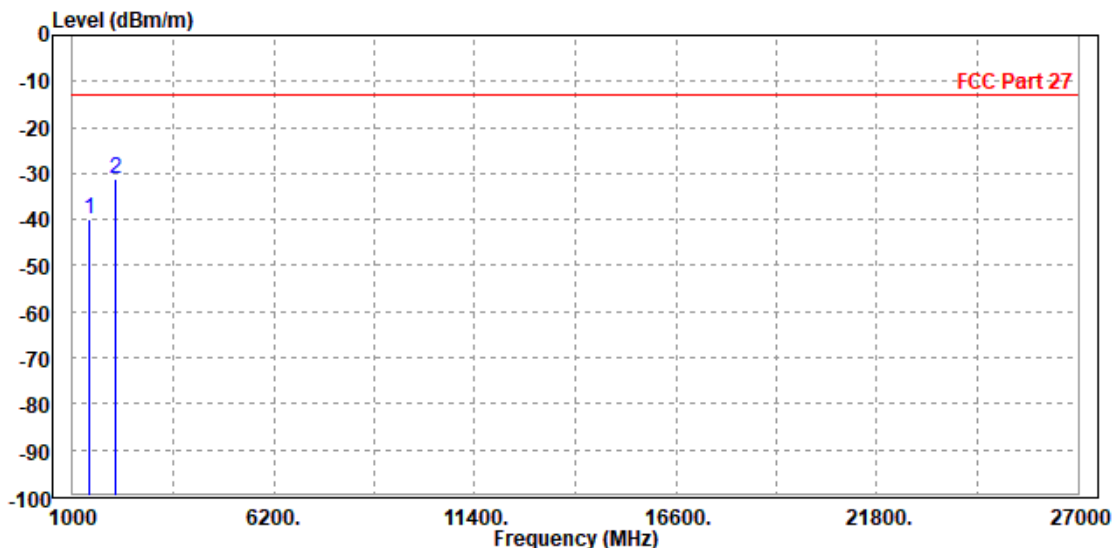



Test Report No.: W7L-P21090022RF06

MODE	TX channel 23790	FREQUENCY RANGE	Above 1000MHz
ENVIRONMENTAL CONDITIONS	23deg. C, 70%RH	INPUT POWER	AC 120V/60Hz
TESTED BY	Jace Hu		
ANTENNA POLARITY & TEST DISTANCE: VERTICAL AT 3 M			

	Freq	Level	Read Level	Limit Line	Over Limit	Factor	Remark	Pol/Phase
	MHz	dBm/m	dBm	dBm/m	dB	dB/m		
1	PP 1416.000	-39.15	-40.84	-13.00	-26.15	1.69	Peak	Vertical
2	2130.000	-39.35	-46.05	-13.00	-26.35	6.70	Peak	Vertical

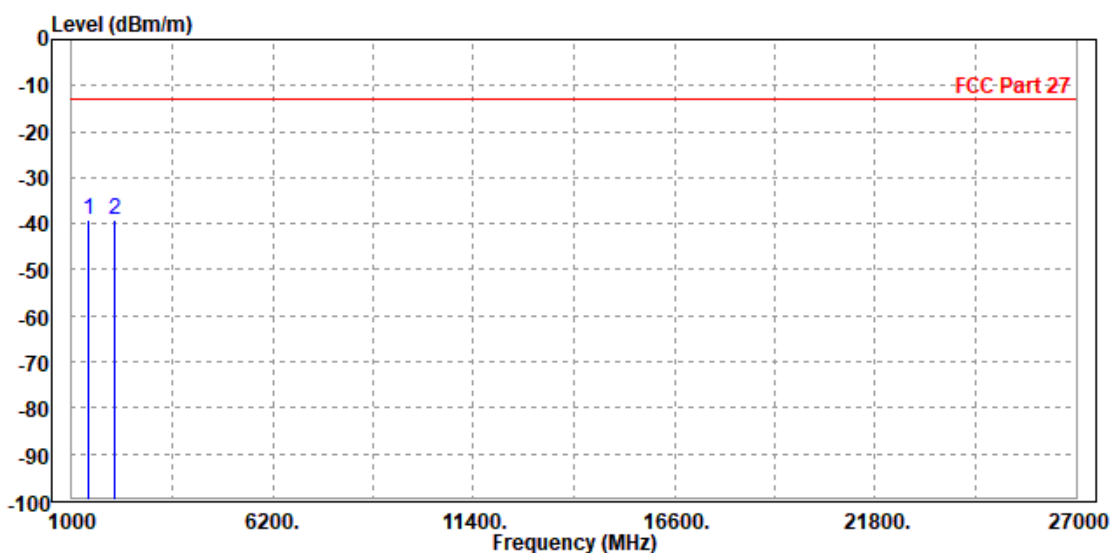



Test Report No.: W7L-P21090022RF06

CH23800

MODE	TX channel 23800	FREQUENCY RANGE	Above 1000MHz
ENVIRONMENTAL CONDITIONS	23deg. C, 70%RH	INPUT POWER	AC 120V/60Hz
TESTED BY	Jace Hu		
ANTENNA POLARITY & TEST DISTANCE: HORIZONTAL AT 3 M			

	Freq	Level	Read Level	Limit Line	Over Limit	Factor	Remark	Pol/Phase
	MHz	dBm/m	dBm	dBm/m	dB	dB/m		
1	1416.000	-48.09	-49.17	-13.00	-35.09	1.08	Peak	Horizontal
2 PP	2133.000	-45.60	-53.28	-13.00	-32.60	7.68	Peak	Horizontal

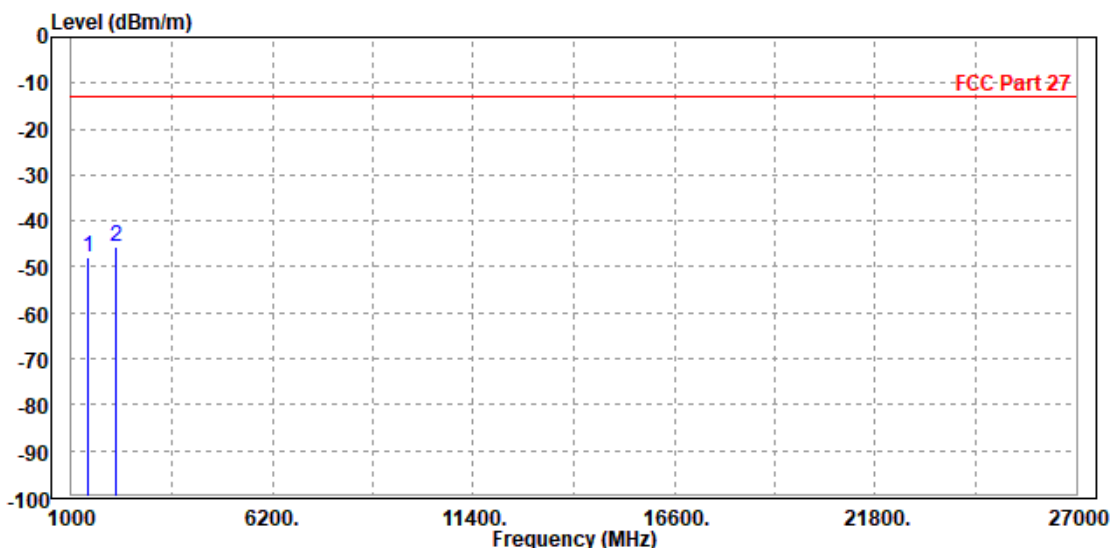



Test Report No.: W7L-P21090022RF06

MODE	TX channel 23800	FREQUENCY RANGE	Above 1000MHz
ENVIRONMENTAL CONDITIONS	23deg. C, 70%RH	INPUT POWER	AC 120V/60Hz
TESTED BY	Jace Hu		
ANTENNA POLARITY & TEST DISTANCE: VERTICAL AT 3 M			

	Freq	Level	Read Level	Limit Line	Over Limit	Factor	Remark	Pol/Phase
	MHz	dBm/m	dBm	dBm/m	dB	dB/m		
1	1416.000	-47.78	-49.47	-13.00	-34.78	1.69	Peak	Vertical
2 PP	2133.000	-47.25	-53.95	-13.00	-34.25	6.70	Peak	Vertical

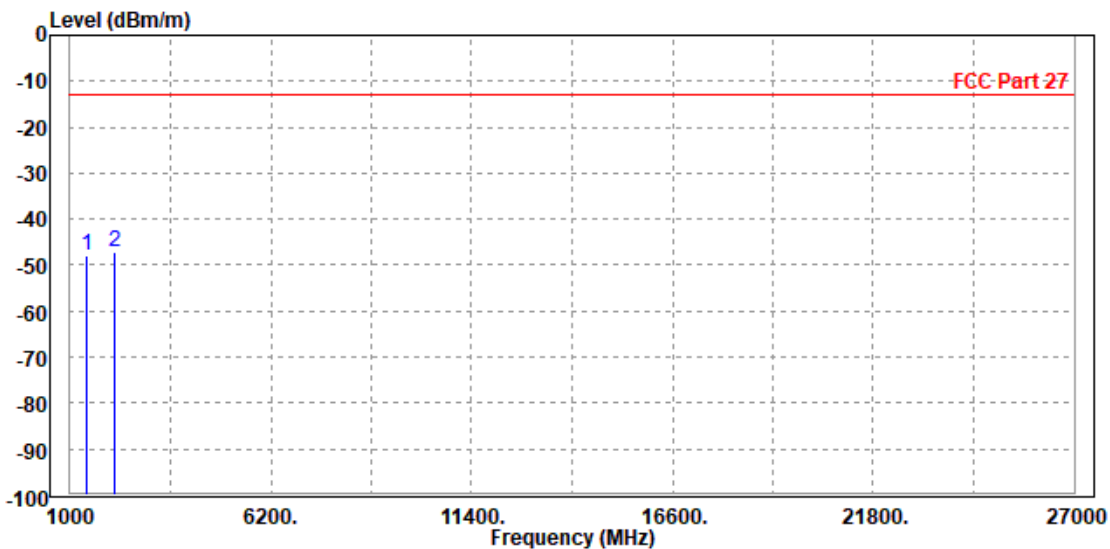

3.7 PEAK TO AVERAGE RATIO

3.7.1 LIMITS OF PEAK TO AVERAGE RATIO MEASUREMENT

In measuring transmissions in this band using an average power technique, the peak to-average ratio (PAR) of the transmission may not exceed 13 dB

3.7.2 TEST SETUP

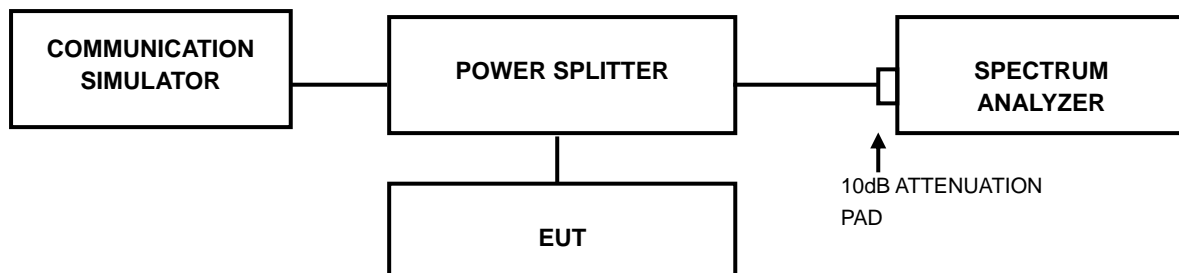

3.7.3 TEST PROCEDURES

1. Set resolution/measurement bandwidth \geq signal's occupied bandwidth;
2. Set the number of counts to a value that stabilizes the measured CCDF curve;
3. Record the maximum PAPR level associated with a probability of 0.1%.



Test Report No.: W7L-P21090022RF06

3.7.4 TEST RESULTS

WCDMA BAND IV

Please Refer to Appendix A 3. of this test report.

LTE BAND 4

Please Refer to Appendix A 3. of this test report.

LTE BAND 12

Please Refer to Appendix A 3. of this test report.

LTE BAND 13

Please Refer to Appendix A 3. of this test report.

LTE BAND 17

Please Refer to Appendix A 3. of this test report.



Test Report No.: W7L-P21090022RF06

4 INFORMATION ON THE TESTING LABORATORIES

We, BV 7LAYERS COMMUNICATIONS TECHNOLOGY (SHENZHEN) CO. LTD., were founded in 2015 to provide our best service in EMC, Radio, Telecom and Safety consultation. Our laboratories are accredited and approved according to ISO/IEC 17025.

If you have any comments, please feel free to contact us at the following:

Shenzhen EMC/RF Lab:

Tel: +86-755-88696566

Fax: +86-755-88696577

Email: customerservice.dg@cn.bureauveritas.com

Web Site: www.adt.com.tw

The address and road map of all our labs can be found in our web site also.



Test Report No.: W7L-P21090022RF06

5 APPENDIX A 3 – MODIFICATIONS RECORDERS FOR ENGINEERING CHANGES TO THE EUT BY THE LAB

No any modifications are made to the EUT by the lab during the test.

NOTE: APPENDIX A 3 is another word.

---END---