

FCC TEST REPORT

(PART 27)

Applicant:	PAX Technology Limited
Address:	Room 2416, 24/F., Sun Hung Kai Centre, 30 Harbour Hong Kong China

Manufacturer or Supplier:	PAX Computer Technology (Shenzhen) Co., Ltd.
Address:	4/F, No.3 Building, Software Park, Second Central Science-Tech Road, High-Tech industrial Park, Shenzhen, Guangdong, P.R.C.
Product:	Integrated Smart Terminal
Brand Name:	PAX
Model Name:	E800
FCC ID:	V5PE800GM
Date of tests:	Sep. 01, 2021 ~ Sep. 26, 2021

The tests have been carried out according to the requirements of the following standard:

- FCC Part 27, Subpart C, M ANSI/TIA/EIA-603-D
 FCC Part 2 ANSI/TIA/EIA-603-E ANSI C63.26-2015

CONCLUSION: The submitted sample was found to COMPLY with the test requirement

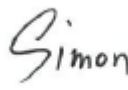
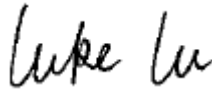
Prepared by Simon Wang Engineer / Mobile Department	Approved by Luke Lu Manager / Mobile Department
	
Date: Sep. 27, 2021	Date: Sep. 27, 2021

This report is governed by, and incorporates by reference, CPS Conditions of Service as posted at the date of issuance of this report at <http://www.bureauveritas.com/home/about-us/our-business/cps/about-us/terms-conditions> and is intended for your exclusive use. Any copying or replication of this report to or for any other person or entity, or use of our name or trademark, is permitted only with our prior written permission. This report sets forth our findings solely with respect to the test samples identified herein. The results set forth in this report are not indicative or representative of the quality or characteristics of the lot from which a test sample was taken or any similar or identical product unless specifically and expressly noted. Our report includes all of the tests requested by you and the results thereof based upon the information that you provided to us. Measurement uncertainty is only provided upon request for accredited tests. You have 60 days from date of issuance of this report to notify us of any material error or omission caused by our negligence or if you require measurement uncertainty; provided, however, that such notice shall be in writing and shall specifically address the issue you wish to raise. A failure to raise such issue within the prescribed time shall constitute your unqualified acceptance of the completeness of this report, the tests conducted and the correctness of the report contents.



TABLE OF CONTENTS

RELEASE CONTROL RECORD	4
1 SUMMARY OF TEST RESULTS	5
1.1 MEASUREMENT UNCERTAINTY	6
1.2 TEST SITE AND INSTRUMENTS	6
2 GENERAL INFORMATION	8
2.1 GENERAL DESCRIPTION OF EUT	8
2.2 CONFIGURATION OF SYSTEM UNDER TEST	11
2.3 DESCRIPTION OF SUPPORT UNITS	12
2.4 TEST ITEM AND TEST CONFIGURATION	12
2.5 GENERAL DESCRIPTION OF APPLIED STANDARDS	17
3 TEST TYPES AND RESULTS	18
3.1 OUTPUT POWER MEASUREMENT	18
3.1.1 LIMITS OF OUTPUT POWER MEASUREMENT	18
3.1.2 TEST PROCEDURES	18
3.1.3 TEST SETUP	19
3.1.4 TEST RESULTS	20
3.2 FREQUENCY STABILITY MEASUREMENT	30
3.2.1 LIMITS OF FREQUENCY STABILITY MEASUREMENT	30
3.2.2 TEST PROCEDURE	30
3.2.3 TEST SETUP	30
3.2.4 TEST RESULTS	31
3.3 OCCUPIED BANDWIDTH MEASUREMENT	32
3.3.1 LIMITS OF OCCUPIED BANDWIDTH MEASUREMENT	32
3.3.2 TEST SETUP	32
3.3.3 TEST PROCEDURES	32
3.3.4 TEST RESULTS	33
3.4 BAND EDGE MEASUREMENT	34
3.4.1 LIMITS OF BAND EDGE MEASUREMENT	34
3.4.2 TEST SETUP	34
3.4.3 TEST PROCEDURES	35
3.4.4 TEST RESULTS	36
3.5 CONDUCTED SPURIOUS EMISSIONS	37
3.5.1 LIMITS OF CONDUCTED SPURIOUS EMISSIONS MEASUREMENT	37
3.5.2 TEST PROCEDURE	37
3.5.3 TEST SETUP	37
3.5.4 TEST RESULTS	38
3.6 RADIATED EMISSION MEASUREMENT	39
3.6.1 LIMITS OF RADIATED EMISSION MEASUREMENT	39
3.6.2 TEST PROCEDURES	39
3.6.3 DEVIATION FROM TEST STANDARD	39
3.6.4 TEST SETUP	40
3.6.5 TEST RESULTS	41
3.7 PEAK TO AVERAGE RATIO	71
3.7.1 LIMITS OF PEAK TO AVERAGE RATIO MEASUREMENT	71
3.7.2 TEST SETUP	71
3.7.3 TEST PROCEDURES	71
3.7.4 TEST RESULTS	72



**BUREAU
VERITAS**

Test Report No.: W7L-P21090006RF07

4 INFORMATION ON THE TESTING LABORATORIES	73
5 APPENDIX A – MODIFICATIONS RECORDERS FOR ENGINEERING CHANGES TO THE EUT BY THE LAB	74



Test Report No.: W7L-P21090006RF07

RELEASE CONTROL RECORD

ISSUE NO.	REASON FOR CHANGE	DATE ISSUED
W7L-P21090006RF07	Original release	Sep. 27, 2021

1 SUMMARY OF TEST RESULTS

The EUT has been tested according to the following specifications:

APPLIED STANDARD: FCC Part 27 & Part 2		
STANDARD SECTION	1.1.1.1.1 TEST TYPE AND LIMIT	RESULT
2.1046 27.50(h)(2)	Equivalent Isotropically Radiated Power	Compliance
2.1055 27.54	Frequency Stability	N/A
2.1049 27.53(m)(6)	Occupied Bandwidth	N/A
2.1051 27.53(m)(4)(6)	Band Edge Measurements	N/A
2.1051 27.53(m)(4)(6)	Conducted Spurious Emissions	N/A
2.1053 27.53(m)(4)(6)	Radiated Spurious Emissions	Compliance

NOTE: N/A refer to original report RF180521W014-3

1.1 MEASUREMENT UNCERTAINTY

Where relevant, the following measurement uncertainty levels have been estimated for tests performed on the EUT as specified in CISPR 16-4-2:

MEASUREMENT	UNCERTAINTY
Frequency Stability	$\pm 76.97\text{Hz}$
Radiated emissions & Radiated Power (30MHz~1GMHz)	$\pm 4.98\text{dB}$
Radiated emissions & Radiated Power (1GMHz ~6GMHz)	$\pm 4.70\text{dB}$
Radiated emissions (6GMHz ~18GMHz)	$\pm 4.60\text{dB}$
Radiated emissions (18GMHz ~40GMHz)	$\pm 4.12\text{dB}$
Conducted emissions	$\pm 4.01\text{dB}$
Occupied Channel Bandwidth	$\pm 43.58\text{KHz}$
Conducted Output power	$\pm 2.06\text{dB}$
Band Edge Measurements	$\pm 4.70\text{dB}$

This uncertainty represents an expanded uncertainty expressed at approximately the 95% confidence level using a coverage factor of $k=2$.

1.2 TEST SITE AND INSTRUMENTS

Equipment	Manufacturer	Model No.	Serial No.	Last Cal.	Next Cal.
MXE EMI Receiver	KEYSIGHT	N9038A-544	MY54450026	Apr. 22,21	Apr. 21,22
EXA Signal Analyzer	KEYSIGHT	N9010A-544	MY54510355	Jun. 03,21	Jun. 02,22
Bilog Antenna	ETS-LINDGREN	3143B	00161965	Mar. 05,21	Mar. 04,22
Horn Antenna	ETS-LINDGREN	3117	00168728	Apr. 02,21	Apr. 01,22
Horn Antenna (18GHz-40GHz)	N/A	QWH-SL-18-40-K-SG/QMS-00361	15433	Aug. 25, 21	Aug. 24, 22
Radio Communication Analyzer	ANRITSU	MT8820C	6201465426	Feb. 25,21	Feb. 24,22
Signal Pre-Amplifier	EMSI	EMC 9135	980249	Jun. 02,21	Jun. 01,22
Signal Pre-Amplifier	EMSI	EMC 012645B	980257	Jun. 03,21	Jun. 02,22
Signal Pre-Amplifier	EMSI	EMC 184045B	980259	Apr. 22,21	Apr. 21,22
3m Semi-anechoic Chamber	ETS-LINDGREN	9m*6m*6m	Euroshieldpn-CT0001143-1216	May. 19,20	May. 18,23
Test Software	E3	V 9.160323	N/A	N/A	N/A
Test Software	ADT	ADT_Radiated_V 7.6.15.9.2	N/A	N/A	N/A
10dB Attenuator	JFW/USA	50HF-010-SMA	1505	Jun. 03,21	Jun. 02,22
Power Meter	Anritsu	ML2495A	1506002	Apr. 07,21	Apr. 06,22
Power Sensor	Anritsu	MA2411B	1339352	May. 07,21	May. 06,22
Temperature	ESPEC	SH-242	93000855	Jun. 02,21	Jun. 01,22



BUREAU
VERITAS

Test Report No.: W7L-P21090006RF07

Chamber					
MXG Analog Microvave Signal Generator	KEYSIGHT	N5183A	MY50143024	Mar. 05,21	Mar. 04,22
Power Divider	MCLI/USA	PS2-15	24880	N/A	N/A

- NOTE:**
1. The calibration interval of the above test instruments is 12 months or 36 months and the calibrations are traceable to CEPREI/CHINA, GRGT/CHINA and NIM/CHINA.
 2. The test was performed in 3m Semi-anechoic Chamber and RF Oven Room.
 3. The horn antenna is used only for the measurement of emission frequency above 1GHz if tested.
 4. The FCC Site Registration No. is 525120; The Designation No. is CN1171.

2 GENERAL INFORMATION

2.1 GENERAL DESCRIPTION OF EUT

PRODUCT	Integrated Smart Terminal	
BRAND NAME	PAX	
MODEL NAME	E800	
NOMINAL VOLTAGE	24Vdc (adapter) 7.2Vdc (Li-ion, battery)	
MODULATION TECHNOLOGY	LTE	QPSK, 16QAM
FREQUENCY RANGE	LTE Band 4 Channel Bandwidth: 1.4MHz	1710.7MHz ~ 1754.3MHz
	LTE Band 4 Channel Bandwidth: 3MHz	1711.5MHz ~ 1753.5MHz
	LTE Band 4 Channel Bandwidth: 5MHz	1712.5MHz ~ 1752.5MHz
	LTE Band 4 Channel Bandwidth: 10MHz	1715MHz ~ 1750MHz
	LTE Band 4 Channel Bandwidth: 15MHz	1717.5MHz ~ 1747.5 MHz
	LTE Band 4 Channel Bandwidth: 20MHz	1720MHz ~ 1745MHz
	LTE Band 12 Channel Bandwidth: 1.4MHz	699.7MHz ~ 715.3MHz
	LTE Band 12 Channel Bandwidth: 3MHz	700.5MHz ~ 714.5MHz
	LTE Band 12 Channel Bandwidth: 5MHz	701.5MHz ~ 713.5MHz
	LTE Band 12 Channel Bandwidth: 10MHz	704MHz ~ 711MHz
	EMISSION DESIGNATOR	LTE Band 4 Channel Bandwidth: 1.4MHz
LTE Band 4 Channel Bandwidth: 3MHz		QPSK: 2M68G7D 16QAM: 2M69W7D
LTE Band 4 Channel Bandwidth: 5MHz		QPSK: 4M48G7D 16QAM: 4M50W7D
LTE Band 4 Channel Bandwidth: 10MHz		QPSK: 8M92G7D 16QAM: 8M94W7D
LTE Band 4 Channel Bandwidth: 15MHz		QPSK: 13M4G7D 16QAM: 13M4W7D
LTE Band 4		QPSK: 17M8G7D



**BUREAU
VERITAS**

Test Report No.: W7L-P21090006RF07

	Channel Bandwidth: 20MHz	16QAM: 17M8W7D	
	LTE Band 12 Channel Bandwidth: 1.4MHz	QPSK: 1M09G7D 16QAM: 1M09W7D	
	LTE Band 12 Channel Bandwidth: 3MHz	QPSK: 2M69G7D 16QAM: 2M69W7D	
	LTE Band 12 Channel Bandwidth: 5MHz	QPSK: 4M49G7D 16QAM: 4M48W7D	
	LTE Band 12 Channel Bandwidth: 10MHz	QPSK: 8M94G7D 16QAM: 8M94W7D	
	MAX. EIRP POWER	LTE Band 4 Channel Bandwidth: 1.4MHz	190.11mW
LTE Band 4 Channel Bandwidth: 3MHz		194.54mW	
LTE Band 4 Channel Bandwidth: 5MHz		194.09mW	
LTE Band 4 Channel Bandwidth: 10MHz		195.88mW	
LTE Band 4 Channel Bandwidth: 15MHz		197.24mW	
LTE Band 4 Channel Bandwidth: 20MHz		202.30mW	
LTE Band 12 Channel Bandwidth: 1.4MHz		91.20mW	
LTE Band 12 Channel Bandwidth: 3MHz		91.62mW	
LTE Band 12 Channel Bandwidth: 5MHz		93.54mW	
LTE Band 12 Channel Bandwidth: 10MHz		93.11mW	
ANTENNA TYPE		Fixed Internal Antenna with 0.5dBi gain for LTE B4 Fixed Internal Antenna with -1.5dBi gain for LTE B12	
I/O PORTS		Refer to user's manual	
CABLE SUPPLIED	N/A		
EXTREME TEMPERATURE	0-50 °C		
EXTREME VOLTAGE	22V- 26V		

NOTE:

1. For a more detailed features description, please refer to the manufacturer's specifications or the user's manual.
2. For the test results, the EUT had been tested with all conditions. But only the worst case was shown in test report.



Test Report No.: W7L-P21090006RF07

List of Accessory:

ACCESSORIES	BRAND	MODEL	SPECIFICATION
Battery	VEKEN	YW-006	Capacity : 7.2vdc 2600mAh
AC Adapter	HONOTO	ADS-65HI-19A-3 24065E	I/P:100-240Vac, 1.5A O/P: 24Vdc, 2.7A

2.2 CONFIGURATION OF SYSTEM UNDER TEST

FOR RADIATION EMISSION TEST

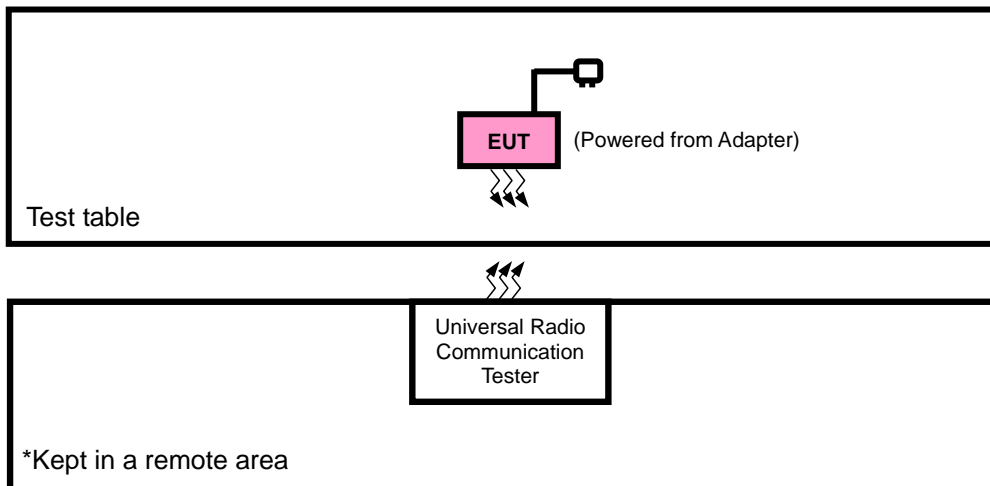



2.3 DESCRIPTION OF SUPPORT UNITS

The EUT has been tested as an independent unit together with other necessary accessories or support units. The following support units or accessories were used to form a representative test configuration during the tests.

NO.	PRODUCT	BRAND	MODEL NO.	SERIAL NO.	FCC ID
1	DC source	LONG WEI	PS-6403D	010934269	N/A

NO.	SIGNAL CABLE DESCRIPTION OF THE ABOVE SUPPORT UNITS
1	DC Line: Unshielded, Detachable 1.0m

2.4 TEST ITEM AND TEST CONFIGURATION

Pre-Scan has been conducted to determine the worst-case mode from all possible combinations between available modulations, data rates, XYZ axis and antenna ports. The worst case was found when positioned on Y-plane for EIRP and X-axis for radiated emission. Following channel(s) was (were) selected for the final test as listed below:

EUT CONFIGURE MODE	DESCRIPTION
A	EUT + DC Source with GPRS or WCDMA or LTE link

LTE BAND 4

EUT CONFIGURE MODE	TEST ITEM	AVAILABLE CHANNEL	TESTED CHANNEL	CHANNEL BANDWIDTH	MODULATION	MODE	
B	EIRP	19957 to 20393	19957, 20175, 20393	1.4MHz	QPSK, 16QAM	1 RB / 0 RB Offset	
		19965 to 20385	19965, 20175, 20385	3MHz	QPSK, 16QAM	1 RB / 0 RB Offset	
		19975 to 20375	19975, 20175, 20375	5MHz	QPSK, 16QAM	1 RB / 0 RB Offset	
		20000 to 20350	20000, 20175, 20350	10MHz	QPSK, 16QAM	1 RB / 0 RB Offset	
		20025 to 20325	20025, 20175, 20325	15MHz	QPSK, 16QAM	1 RB / 0 RB Offset	
		20050 to 20300	20050, 20175, 20300	20MHz	QPSK, 16QAM	1 RB / 0 RB Offset	
B	FREQUENCY STABILITY	19957 to 20393	19957, 20393	1.4MHz	QPSK	1 RB / 0 RB Offset	
		19965 to 20385	19965, 20385	3MHz	QPSK	1 RB / 0 RB Offset	
		19975 to 20375	19975, 20375	5MHz	QPSK	1 RB / 0 RB Offset	
		20000 to 20350	20000, 20350	10MHz	QPSK	1 RB / 0 RB Offset	
		20025 to 20325	20025, 20325	15MHz	QPSK	1 RB / 0 RB Offset	
		20050 to 20300	20050, 20300	20MHz	QPSK	1 RB / 0 RB Offset	
B	OCCUPIED BANDWIDTH	19957 to 20393	19957, 20175, 20393	1.4MHz	QPSK, 16QAM	6 RB / 0 RB Offset	
		19965 to 20385	19965, 20175, 20385	3MHz	QPSK, 16QAM	15 RB / 0 RB Offset	
		19975 to 20375	19975, 20175, 20375	5MHz	QPSK, 16QAM	25 RB / 0 RB Offset	
		20000 to 20350	20000, 20175, 20350	10MHz	QPSK, 16QAM	50 RB / 0 RB Offset	
		20025 to 20325	20025, 20175, 20325	15MHz	QPSK, 16QAM	75 RB / 0 RB Offset	
		20050 to 20300	20050, 20175, 20300	20MHz	QPSK, 16QAM	100 RB / 0 RB Offset	
B	PEAK TO AVERAGE RATIO	19957 to 20393	19957, 20175, 20393	1.4MHz	QPSK, 16QAM	1 RB / 0 RB Offset	
		19965 to 20385	19965, 20175, 20385	3MHz	QPSK, 16QAM	1 RB / 0 RB Offset	
		19975 to 20375	19975, 20175, 20375	5MHz	QPSK, 16QAM	1 RB / 0 RB Offset	
		20000 to 20350	20000, 20175, 20350	10MHz	QPSK, 16QAM	1 RB / 0 RB Offset	
		20025 to 20325	20025, 20175, 20325	15MHz	QPSK, 16QAM	1 RB / 0 RB Offset	
		20050 to 20300	20050, 20175, 20300	20MHz	QPSK, 16QAM	1 RB / 0 RB Offset	
B	BAND EDGE	19957 to 20393	19957	1.4MHz	QPSK, 16QAM	1 RB / 0 RB Offset	
			20393	1.4MHz	QPSK, 16QAM	6 RB / 0 RB Offset	
		19965 to 20385	19965	3MHz	QPSK, 16QAM	1 RB / 0 RB Offset	
			20385	3MHz	QPSK, 16QAM	15 RB / 0 RB Offset	
		19975 to 20375	19975	5MHz	QPSK, 16QAM	1 RB / 0 RB Offset	
			20375	5MHz	QPSK, 16QAM	25 RB / 0 RB Offset	
		20000 to 20350	20000	10MHz	QPSK, 16QAM	1 RB / 0 RB Offset	
			20350	10MHz	QPSK, 16QAM	50 RB / 0 RB Offset	
							1 RB / 49 RB Offset
							50 RB / 0 RB Offset

B	BAND EDGE	20025 to 20325	20025	15MHz	QPSK, 16QAM	1 RB / 0 RB Offset
			20325	15MHz	QPSK, 16QAM	75 RB / 0 RB Offset
		20050 to 20300	20050	20MHz	QPSK, 16QAM	1 RB / 74 RB Offset
				20300	20MHz	QPSK, 16QAM
			20050	20MHz	QPSK, 16QAM	1 RB / 0 RB Offset
				20300	20MHz	QPSK, 16QAM
B	CONDCUDETED EMISSION	19957 to 20393	19957, 20175, 20393	1.4MHz	QPSK	1 RB / 0 RB Offset
		19965 to 20385	19965, 20175, 20385	3MHz	QPSK	1 RB / 0 RB Offset
		19975 to 20375	19975, 20175, 20375	5MHz	QPSK	1 RB / 0 RB Offset
		20000 to 20350	20000, 20175, 20350	10MHz	QPSK	1 RB / 0 RB Offset
		20025 to 20325	20025, 20175, 20325	15MHz	QPSK	1 RB / 0 RB Offset
		20050 to 20300	20050, 20175, 20300	20MHz	QPSK	1 RB / 0 RB Offset
A	RADIATED EMISSION	19957 to 20393	19957, 20175, 20393	1.4MHz	QPSK	1 RB / 0 RB Offset
		19965 to 20385	20175	3MHz	QPSK	1 RB / 0 RB Offset
		19975 to 20375	20175	5MHz	QPSK	1 RB / 0 RB Offset
		20000 to 20350	20175	10MHz	QPSK	1 RB / 0 RB Offset
		20025 to 20325	20175	15MHz	QPSK	1 RB / 0 RB Offset
		20050 to 20300	20175	20MHz	QPSK	1 RB / 0 RB Offset

Note: This device was tested under all bandwidths, RB configurations and modulations. The worst case was found in QPSK modulation.

LTE BAND 12

EUT CONFIGURE MODE	TEST ITEM	AVAILABLE CHANNEL	TESTED CHANNEL	CHANNEL BANDWIDTH	MODULATION	MODE		
B	ERP	23017 to 23173	23017, 23095 , 23173	1.4MHz	QPSK, 16QAM	1 RB / 0 RB Offset		
		23025 to 23165	23025, 23095 ,23165	3MHz	QPSK, 16QAM	1 RB / 0 RB Offset		
		23035 to 23155	23035, 23095 ,23155	5MHz	QPSK, 16QAM	1 RB / 0 RB Offset		
		23060 to 23130	23060, 23095 ,23130	10MHz	QPSK, 16QAM	1 RB / 0 RB Offset		
B	FREQUENCY STABILITY	23017 to 23173	23017, 23173	1.4MHz	QPSK	1 RB / 0 RB Offset		
		23025 to 23165	23025, 23165	3MHz	QPSK	1 RB / 0 RB Offset		
		23035 to 23155	23035, 23155	5MHz	QPSK	1 RB / 0 RB Offset		
		23060 to 23130	23060, 23130	10MHz	QPSK	1 RB / 0 RB Offset		
B	OCCUPIED BANDWIDTH	23017 to 23173	23017, 23095 , 23173	1.4MHz	QPSK, 16QAM	6 RB / 0 RB Offset		
		23025 to 23165	23025, 23095 ,23165	3MHz	QPSK, 16QAM	15 RB / 0 RB Offset		
		23035 to 23155	23035, 23095 ,23155	5MHz	QPSK, 16QAM	25 RB / 0 RB Offset		
		23060 to 23130	23060, 23095 ,23130	10MHz	QPSK, 16QAM	50 RB / 0 RB Offset		
B	PEAK TO AVERAGE RATIO	23017 to 23173	23017, 23095 , 23173	1.4MHz	QPSK, 16QAM	1 RB / 0 RB Offset		
		23025 to 23165	23025, 23095 ,23165	3MHz	QPSK, 16QAM	1 RB / 0 RB Offset		
		23035 to 23155	23035, 23095 ,23155	5MHz	QPSK, 16QAM	1 RB / 0 RB Offset		
		23060 to 23130	23060, 23095 ,23130	10MHz	QPSK, 16QAM	1 RB / 0 RB Offset		
B	BAND EDGE	23017 to 23173	23017	1.4MHz	QPSK	1 RB / 0 RB Offset 6 RB / 0 RB Offset		
			23173	1.4MHz	QPSK	1 RB / 5 RB Offset 6 RB / 0 RB Offset		
		23025 to 23165	23025	3MHz	QPSK	1 RB / 0 RB Offset 15 RB / 0 RB Offset		
			23165	3MHz	QPSK	1 RB / 14 RB Offset 15 RB / 0 RB Offset		
		23035 to 23155	23035	5MHz	QPSK	1 RB / 0 RB Offset 25 RB / 0 RB Offset		
			23155	5MHz	QPSK	1 RB / 24 RB Offset 25 RB / 0 RB Offset		
		23060 to 23130	23060	10MHz	QPSK	1 RB / 0 RB Offset 50 RB / 0 RB Offset		
			23130	10MHz	QPSK	1 RB / 49 RB Offset 50 RB / 0 RB Offset		
		B	CONDCUETED EMISSION	23017 to 23173	23017, 23095 , 23173	1.4MHz	QPSK	1 RB / 0 RB Offset
				23025 to 23165	23025, 23095 ,23165	3MHz	QPSK	1 RB / 0 RB Offset
				23035 to 23155	23035, 23095 ,23155	5MHz	QPSK	1 RB / 0 RB Offset
				23060 to 23130	23060, 23095 ,23130	10MHz	QPSK	1 RB / 0 RB Offset
A	RADIATED EMISSION	23017 to 23173	23095	1.4MHz	QPSK	1 RB / 0 RB Offset		
		23025 to 23165	23095	3MHz	QPSK	1 RB / 0 RB Offset		
		23035 to 23155	23095	5MHz	QPSK	1 RB / 0 RB Offset		
		23060 to 23130	23060, 23095 ,23130	10MHz	QPSK	1 RB / 0 RB Offset		

Note: This device was tested under all bandwidths, RB configurations and modulations. The worst case was found in QPSK modulation.



Test Report No.: W7L-P21090006RF07

TEST CONDITION:

TEST ITEM	ENVIRONMENTAL CONDITIONS	INPUT POWER	TESTED BY
ERP/EIRP	23deg. C, 70%RH	DC 24V	Jace Hu
RADIATED EMISSION	23deg. C, 70%RH	DC 24V	Jace Hu



Test Report No.: W7L-P21090006RF07

2.5 GENERAL DESCRIPTION OF APPLIED STANDARDS

The EUT is a RF product. According to the specifications of the manufacturer, it must comply with the requirements of the following standards:

FCC 47 CFR Part 2

FCC 47 CFR Part 27

KDB 971168 D01 Power Meas License Digital Systems v03r01

ANSI/TIA/EIA-603-D

ANSI/TIA/EIA-603-E

ANSI C63.26-2015

NOTE: All test items have been performed and recorded as per the above standards.



3 TEST TYPES AND RESULTS

3.1 OUTPUT POWER MEASUREMENT

3.1.1 LIMITS OF OUTPUT POWER MEASUREMENT

The radiated peak output power shall be according to the specific rule Part 27.50(h)(2) that “User stations are limited to 2 watts” and 27.50(i) specific that “Peak transmit power must be measure over any interval of continuous transmission using instrumentation calibration in terms of rms-equivalent voltage.”

Fixed, mobile, and portable (hand-held) stations operating in the 1710-1755 MHz band and mobile and portable stations operating in the 1695-1710 MHz and 1755-1780 MHz bands are limited to 1 watt EIRP

3.1.2 TEST PROCEDURES

EIRP MEASUREMENT:

Per KDB 971168 D01 Power Meas License Digital Systems v03r01 or subclause 5.2.5.5 of ANSI C63.26-2015, the relevant equation for determining the ERP or EIRP from the conducted RF output power measured using the guidance provided above is:

$$\text{ERP or EIRP} = P_{\text{Meas}} + G_{\text{T}} - L_{\text{C}}$$

Where:

ERP or EIRP = effective radiated power or equivalent isotropically radiated power, respectively

(expressed in the same units as P_{Meas} , typically dBW or dBm);

P_{Meas} = measured transmitter output power or PSD, in dBm or dBW;

G_{T} = gain of the transmitting antenna, in dBd (ERP) or dBi (EIRP);

L_{C} = signal attenuation in the connecting cable between the transmitter and antenna, in dB.

CONDUCTED POWER MEASUREMENT:

- a. The EUT was set up for the maximum power with LTE link data modulation and link up with simulator.
- b. Set the EUT to transmit under low, middle and high channel and record the power level shown on simulator.



Test Report No.: W7L-P21090006RF07

3.1.3 TEST SETUP

CONDUCTED POWER MEASUREMENT:

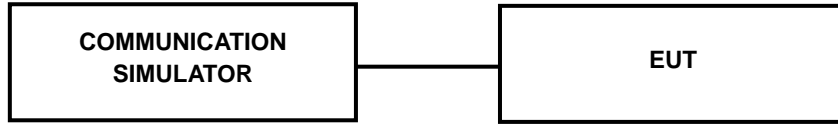

For the actual test configuration, please refer to the attached file (Test Setup Photo).

3.1.4 TEST RESULTS

AVERAGE CONDUCTED OUTPUT POWER (dBm)

LTE Band 4

Band/BW	Modulation	RB Size	RB Offset	Low CH 19957	Mid CH 20175	High CH 20393	MPR
				Frequency 1710.7 MHz	Frequency 1732.5 MHz	Frequency 1754.3 MHz	
4/ 1.4	QPSK	1	0	22.18	22.26	22.15	0
		1	2	22.14	22.19	22.14	0
		1	5	22.26	22.29	22.22	0
		3	0	22.06	22.12	22.16	0
		3	1	22.11	22.16	22.01	0
		3	3	22.04	22.09	22.10	0
	16QAM	6	0	21.12	21.11	21.10	1
		1	0	20.96	21.03	20.94	1
		1	2	21.05	21.05	21.08	1
		1	5	20.90	20.98	20.98	1
		3	0	21.23	21.23	21.24	1
		3	1	20.97	21.15	21.04	1
		3	3	21.19	21.22	21.24	1
		6	0	20.05	20.12	20.00	2

Band/BW	Modulation	RB Size	RB Offset	Low CH 19965	Mid CH 20175	High CH 20385	MPR
				Frequency 1711.5 MHz	Frequency 1732.5 MHz	Frequency 1753.5 MHz	
4/ 3	QPSK	1	0	22.30	22.38	22.24	0
		1	7	22.20	22.30	22.24	0
		1	14	22.32	22.39	22.32	0
		8	0	21.15	21.25	21.26	1
		8	3	21.14	21.26	21.13	1
		8	7	21.11	21.26	21.24	1
		15	0	21.19	21.22	21.14	1
	16QAM	1	0	21.03	21.19	21.07	1
		1	7	21.12	21.18	21.16	1
		1	14	21.03	21.08	21.08	1
		8	0	20.29	20.34	20.34	2
		8	3	20.12	20.20	20.17	2
		8	7	20.31	20.30	20.30	2
		15	0	20.15	20.16	20.13	2

Band/BW	Modulation	RB Size	RB Offset	Low CH 19975	Mid CH 20175	High CH 20375	MPR
				Frequency 1712.5 MHz	Frequency 1732.5 MHz	Frequency 1752.5 MHz	
4/ 5	QPSK	1	0	22.31	22.33	22.25	0
		1	12	22.25	22.27	22.24	0
		1	24	22.33	22.38	22.36	0
		12	0	21.18	21.25	21.23	1
		12	6	21.14	21.27	21.14	1
		12	13	21.15	21.22	21.25	1
		25	0	21.17	21.25	21.17	1
	16QAM	1	0	21.04	21.15	21.07	1
		1	12	21.09	21.21	21.15	1
		1	24	21.03	21.08	21.07	1
		12	0	20.29	20.32	20.31	2
		12	6	20.09	20.24	20.13	2
		12	13	20.26	20.32	20.33	2
		25	0	20.15	20.17	20.10	2

Band/BW	Modulation	RB Size	RB Offset	Low CH 20000	Mid CH 20175	High CH 20350	MPR
				Frequency 1715 MHz	Frequency 1732.5 MHz	Frequency 1750 MHz	
4/ 10	QPSK	1	0	22.28	22.36	22.25	0
		1	24	22.25	22.27	22.25	0
		1	49	22.30	22.42	22.32	0
		25	0	21.19	21.24	21.26	1
		25	12	21.20	21.21	21.14	1
		25	25	21.13	21.19	21.24	1
		50	0	21.22	21.25	21.14	1
	16QAM	1	0	21.04	21.12	21.03	1
		1	24	21.14	21.17	21.18	1
		1	49	21.03	21.09	21.04	1
		25	0	20.31	20.30	20.37	2
		25	12	20.13	20.18	20.18	2
		25	25	20.25	20.33	20.30	2
		50	0	20.19	20.16	20.14	2

Band/BW	Modulation	RB Size	RB Offset	Low CH 20025	Mid CH 20175	High CH 20325	MPR
				Frequency 1717.5 MHz	Frequency 1732.5 MHz	Frequency 1747.5 MHz	
4/ 15	QPSK	1	0	22.35	22.36	22.22	0
		1	37	22.23	22.32	22.20	0
		1	74	22.36	22.45	22.33	0
		36	0	21.16	21.25	21.27	1
		36	19	21.21	21.26	21.14	1
		36	39	21.11	21.20	21.24	1
		75	0	21.22	21.23	21.19	1
	16QAM	1	0	21.08	21.19	21.03	1
		1	37	21.13	21.18	21.18	1
		1	74	20.99	21.14	21.06	1
		36	0	20.35	20.30	20.38	2
		36	19	20.07	20.22	20.14	2
		36	39	20.30	20.31	20.33	2
		75	0	20.20	20.19	20.07	2

Band/BW	Modulation	RB Size	RB Offset	Low CH 20050	Mid CH 20175	High CH 20300	MPR
				Frequency 1720 MHz	Frequency 1732.5 MHz	Frequency 1745 MHz	
4/ 20	QPSK	1	0	22.46	22.50	22.40	0
		1	50	22.37	22.45	22.36	0
		1	99	22.48	22.56	22.47	0
		50	0	21.32	21.40	21.38	1
		50	25	21.32	21.38	21.29	1
		50	50	21.29	21.37	21.36	1
		100	0	21.33	21.37	21.32	1
	16QAM	1	0	21.21	21.30	21.19	1
		1	50	21.27	21.33	21.30	1
		1	99	21.15	21.26	21.19	1
		50	0	20.47	20.48	20.49	2
		50	25	20.25	20.36	20.29	2
		50	50	20.43	20.47	20.45	2
		100	0	20.31	20.34	20.25	2



**BUREAU
VERITAS**

Test Report No.: W7L-P21090006RF07

LTE Band 12

Band/BW	Modulation	RB Size	RB Offset	Low CH 23017	Mid CH 23095	High CH 23173	MPR
				Frequency 699.7 MHz	Frequency 707.5 MHz	Frequency 715.3 MHz	
12/ 1.4	QPSK	1	0	22.54	22.62	22.43	0
		1	2	23.03	23.00	22.90	0
		1	5	23.19	23.17	23.06	0
		3	0	22.84	22.87	22.73	0
		3	1	23.13	23.25	22.95	0
		3	3	23.22	23.24	23.10	0
		6	0	22.14	22.19	22.00	1
	16QAM	1	0	21.05	21.11	20.96	1
		1	2	21.81	21.87	21.70	1
		1	5	22.19	22.16	22.09	1
		3	0	21.85	21.92	21.70	1
		3	1	22.04	22.21	21.93	1
		3	3	22.17	22.24	22.11	1
		6	0	20.85	20.94	20.73	2

Band/BW	Modulation	RB Size	RB Offset	Low CH 23025	Mid CH 23095	High CH 23165	MPR
				Frequency 700.5 MHz	Frequency 707.5 MHz	Frequency 714.5 MHz	
12/ 3	QPSK	1	0	22.66	22.74	22.52	0
		1	7	23.09	23.11	23.00	0
		1	14	23.25	23.27	23.16	0
		8	0	21.93	22.00	21.83	1
		8	3	22.16	22.35	22.07	1
		8	7	22.29	22.41	22.24	1
		15	0	22.21	22.30	22.04	1
	16QAM	1	0	21.12	21.27	21.09	1
		1	7	21.88	22.00	21.78	1
		1	14	22.32	22.26	22.19	1
		8	0	20.91	21.03	20.80	2
		8	3	21.19	21.26	21.06	2
		8	7	21.29	21.32	21.17	2
		15	0	20.95	20.98	20.86	2

Band/BW	Modulation	RB Size	RB Offset	Low CH 23035	Mid CH 23095	High CH 23155	MPR
				Frequency 701.5 MHz	Frequency 707.5 MHz	Frequency 713.5 MHz	
12/ 5	QPSK	1	0	22.77	22.79	22.63	0
		1	12	23.24	23.18	23.10	0
		1	24	23.36	23.36	23.30	0
		12	0	22.06	22.10	21.90	1
		12	6	22.26	22.46	22.18	1
		12	13	22.43	22.47	22.35	1
	16QAM	25	0	22.29	22.43	22.17	1
		1	0	21.23	21.33	21.19	1
		1	12	21.95	22.13	21.87	1
		1	24	22.42	22.36	22.28	1
		12	0	21.01	21.11	20.87	2
		12	6	21.26	21.40	21.12	2
		12	13	21.34	21.44	21.30	2
		25	0	21.05	21.09	20.93	2

Band/BW	Modulation	RB Size	RB Offset	Low CH 23060	Mid CH 23095	High CH 23130	MPR
				Frequency 704 MHz	Frequency 707.5 MHz	Frequency 711 MHz	
12/ 10	QPSK	1	0	22.72	22.76	22.58	0
		1	24	23.16	23.16	23.02	0
		1	49	23.31	23.34	23.21	0
		25	0	22.00	22.05	21.85	1
		25	12	22.24	22.37	22.13	1
		25	25	22.37	22.42	22.26	1
		50	0	22.25	22.35	22.12	1
	16QAM	1	0	21.20	21.28	21.11	1
		1	24	21.93	22.05	21.82	1
		1	49	22.34	22.34	22.20	1
		25	0	20.99	21.07	20.85	2
		25	12	21.22	21.32	21.08	2
		25	25	21.31	21.39	21.22	2
		50	0	21.01	21.06	20.88	2



EIRP

Test Report No.: W7L-P21090006RF07

LTE BAND 4

CHANNEL BANDWIDTH: 1.4MHz QPSK

Channel	Frequency (MHz)	Conducted Power (dBm)	G _T -L _c (dB)	EIRP (dBm)	EIRP (mW)	Limit (W)
19957	1710.7	22.26	0.5	22.76	188.8	1
20175	1732.5	22.29	0.5	22.79	190.11	1
20393	1754.3	22.22	0.5	22.72	187.07	1

CHANNEL BANDWIDTH: 1.4MHz 16QAM

Channel	Frequency (MHz)	Conducted Power (dBm)	G _T -L _c (dB)	EIRP (dBm)	EIRP (mW)	Limit (W)
19957	1710.7	21.23	0.5	21.73	148.94	1
20175	1732.5	21.23	0.5	21.73	148.94	1
20393	1754.3	21.24	0.5	21.74	149.28	1

CHANNEL BANDWIDTH: 3MHz QPSK

Channel	Frequency (MHz)	Conducted Power (dBm)	G _T -L _c (dB)	EIRP (dBm)	EIRP (mW)	Limit (W)
19965	1711.5	22.32	0.5	22.82	191.43	1
20175	1732.5	22.39	0.5	22.89	194.54	1
20385	1753.5	22.32	0.5	22.82	191.43	1

CHANNEL BANDWIDTH: 3MHz 16QAM

Channel	Frequency (MHz)	Conducted Power (dBm)	G _T -L _c (dB)	EIRP (dBm)	EIRP (mW)	Limit (W)
19965	1711.5	21.12	0.5	21.62	145.21	1
20175	1732.5	21.19	0.5	21.69	147.57	1
20385	1753.5	20.13	0.5	20.63	115.61	1

CHANNEL BANDWIDTH: 5MHz QPSK

Channel	Frequency (MHz)	Conducted Power (dBm)	G _T -L _c (dB)	EIRP (dBm)	EIRP (mW)	Limit (W)
19975	1712.5	22.33	0.5	22.83	191.87	1
20175	1732.5	22.38	0.5	22.88	194.09	1
20375	1752.5	22.36	0.5	22.86	193.2	1

CHANNEL BANDWIDTH: 5MHz 16QAM

Channel	Frequency (MHz)	Conducted Power (dBm)	G _T -L _c (dB)	EIRP (dBm)	EIRP (mW)	Limit (W)
19975	1712.5	21.09	0.5	21.59	144.21	1
20175	1732.5	21.21	0.5	21.71	148.25	1
20375	1752.5	21.15	0.5	21.65	146.22	1

CHANNEL BANDWIDTH: 10MHz QPSK

Channel	Frequency (MHz)	Conducted Power (dBm)	G _T -L _c (dB)	EIRP (dBm)	EIRP (mW)	Limit (W)
20000	1715	22.3	0.5	22.8	190.55	1
20175	1732.5	22.42	0.5	22.92	195.88	1
20350	1750	22.32	0.5	22.82	191.43	1

CHANNEL BANDWIDTH: 10MHz 16QAM

Channel	Frequency (MHz)	Conducted Power (dBm)	G _T -L _c (dB)	EIRP (dBm)	EIRP (mW)	Limit (W)
20000	1715	21.14	0.5	21.64	145.88	1
20175	1732.5	21.17	0.5	21.67	146.89	1
20350	1750	21.18	0.5	21.68	147.23	1

CHANNEL BANDWIDTH: 15MHz QPSK

Channel	Frequency (MHz)	Conducted Power (dBm)	G _T -L _c (dB)	EIRP (dBm)	EIRP (mW)	Limit (W)
20025	1717.5	22.36	0.5	22.86	193.2	1
20175	1732.5	22.45	0.5	22.95	197.24	1
20325	1747.5	22.33	0.5	22.83	191.87	1

CHANNEL BANDWIDTH: 15MHz 16QAM

Channel	Frequency (MHz)	Conducted Power (dBm)	G _T -L _c (dB)	EIRP (dBm)	EIRP (mW)	Limit (W)
20025	1717.5	21.13	0.5	21.63	145.55	1
20175	1732.5	21.19	0.5	21.69	147.57	1
20325	1747.5	21.18	0.5	21.68	147.23	1

CHANNEL BANDWIDTH: 20MHz QPSK

Channel	Frequency (MHz)	Conducted Power (dBm)	G _T -L _c (dB)	EIRP (dBm)	EIRP (mW)	Limit (W)
20050	1720	22.48	0.5	22.98	198.61	1
20175	1732.5	22.56	0.5	23.06	202.30	1
20300	1745	22.47	0.5	22.97	198.15	1

CHANNEL BANDWIDTH: 20MHz 16QAM

Channel	Frequency (MHz)	Conducted Power (dBm)	G _T -L _c (dB)	EIRP (dBm)	EIRP (mW)	Limit (W)
20050	1720	21.27	0.5	21.77	150.31	1
20175	1732.5	21.33	0.5	21.83	152.41	1
20300	1745	21.3	0.5	21.8	151.36	1

REMARKS: ERP Output Power (dBm) = EIRP (dBm) -2.15(dB).

ERP

LTE BAND 12

CHANNEL BANDWIDTH: 1.4MHz QPSK

Channel	Frequency (MHz)	Conducted Power (dBm)	G _T -L _c (dB)	ERP (dBm)	ERP (mW)	Limit (W)
23017	699.7	23.22	-1.5	19.57	90.57	3
23095	707.5	23.25	-1.5	19.6	91.20	3
23173	715.3	23.1	-1.5	19.45	88.1	3

CHANNEL BANDWIDTH: 1.4MHz 16QAM

Channel	Frequency (MHz)	Conducted Power (dBm)	G _T -L _c (dB)	ERP (dBm)	ERP (mW)	Limit (W)
23017	699.7	22.19	-1.5	18.54	71.45	3
23095	707.5	22.24	-1.5	18.59	72.28	3
23173	715.3	22.11	-1.5	18.46	70.15	3

CHANNEL BANDWIDTH: 3MHz QPSK

Channel	Frequency (MHz)	Conducted Power (dBm)	G _T -L _c (dB)	ERP (dBm)	ERP (mW)	Limit (W)
23025	700.5	23.25	-1.5	19.6	91.2	3
23095	707.5	23.27	-1.5	19.62	91.62	3
23165	714.5	23.16	-1.5	19.51	89.33	3

CHANNEL BANDWIDTH: 3MHz 16QAM

Channel	Frequency (MHz)	Conducted Power (dBm)	G _T -L _c (dB)	ERP (dBm)	ERP (mW)	Limit (W)
23025	700.5	22.32	-1.5	18.67	73.62	3
23095	707.5	22.26	-1.5	18.61	72.61	3
23165	714.5	22.19	-1.5	18.54	71.45	3

CHANNEL BANDWIDTH: 5MHz QPSK

Channel	Frequency (MHz)	Conducted Power (dBm)	G _T -L _c (dB)	ERP (dBm)	ERP (mW)	Limit (W)
23035	701.5	23.36	-1.5	19.71	93.54	3
23095	707.5	23.36	-1.5	19.71	93.54	3
23155	713.5	23.3	-1.5	19.65	92.26	3

CHANNEL BANDWIDTH: 5MHz 16QAM

Channel	Frequency (MHz)	Conducted Power (dBm)	G _T -L _c (dB)	ERP (dBm)	ERP (mW)	Limit (W)
23035	701.5	22.42	-1.5	18.77	75.34	3
23095	707.5	22.36	-1.5	18.71	74.3	3
23155	713.5	22.28	-1.5	18.63	72.95	3

CHANNEL BANDWIDTH: 10MHz QPSK

Channel	Frequency (MHz)	Conducted Power (dBm)	G _T -L _c (dB)	ERP (dBm)	ERP (mW)	Limit (W)
23060	704	23.31	-1.5	19.66	92.47	3
23095	707.5	23.34	-1.5	19.69	93.11	3
23130	711	23.21	-1.5	19.56	90.36	3

CHANNEL BANDWIDTH: 10MHz 16QAM

Channel	Frequency (MHz)	Conducted Power (dBm)	G _T -L _c (dB)	ERP (dBm)	ERP (mW)	Limit (W)
23060	704	22.34	-1.5	18.69	73.96	3
23095	707.5	22.34	-1.5	18.69	73.96	3
23130	711	22.2	-1.5	18.55	71.61	3

REMARKS: ERP Output Power (dBm) = ERP (dBm) -2.15(dB).

3.2 FREQUENCY STABILITY MEASUREMENT

3.2.1 LIMITS OF FREQUENCY STABILITY MEASUREMENT

The frequency stability shall be sufficient to ensure that the fundamental emissions stay within the authorized bands of operation.

3.2.2 TEST PROCEDURE

- a. Device is placed at the oven room. The oven room could control the temperatures and humidity. Power warm up is at least 15 min and power applied should perform before recording frequency error.
- b. EUT is connected the external power supply to control the DC input power. The test voltage range is from minimum to maximum working voltage. Each step shall be record the frequency error rate.
- c. The temperature range step is 10 degrees in this test items. All temperature levels shall be hold the $\pm 0.5^{\circ}\text{C}$ during the measurement testing. The each temperature step shall be at least 0.5 hours, consider the EUT could be test under the stability condition.

NOTE: The frequency error was recorded frequency error from the communication simulator.

3.2.3 TEST SETUP

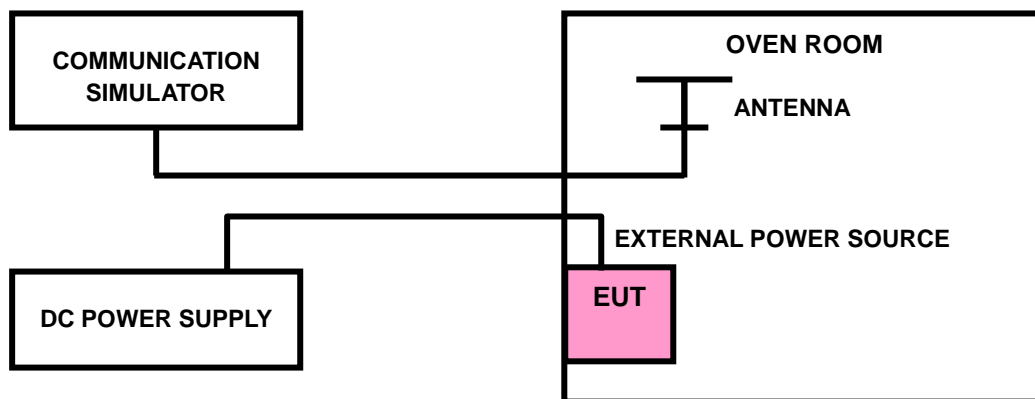



Test Report No.: W7L-P21090006RF07

3.2.4 TEST RESULTS

NOTE: N/A refer to original report RF180521W014-3

3.3 OCCUPIED BANDWIDTH MEASUREMENT

3.3.1 LIMITS OF OCCUPIED BANDWIDTH MEASUREMENT

The width of a frequency band such that, below the lower and above the upper frequency limits, the mean powers emitted are each equal to a specified percentage 0.5 %of the total mean power of a given emission.

3.3.2 TEST SETUP

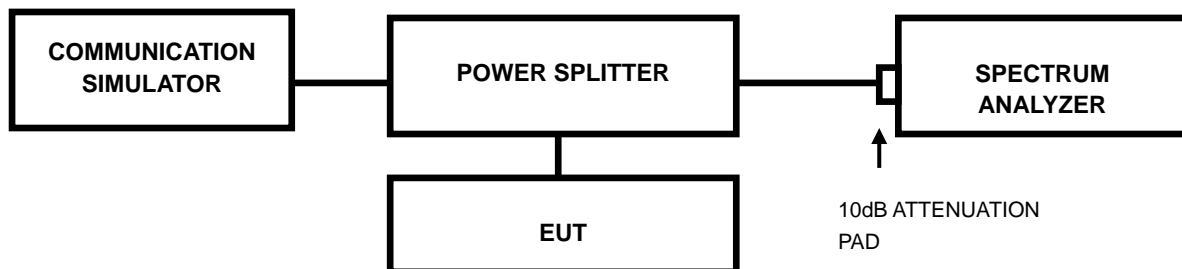

3.3.3 TEST PROCEDURES

- The conducted occupied bandwidth used the power splitter via EUT RF power connector between simulation base station and spectrum analyzer.
- Use OBW measurement function of Spectrum analyzer to measure 99 % occupied bandwidth.



Test Report No.: W7L-P21090006RF07

3.3.4 TEST RESULTS

NOTE: N/A refer to original report RF180521W014-3

3.4 BAND EDGE MEASUREMENT

3.4.1 LIMITS OF BAND EDGE MEASUREMENT

According to FCC 27.53(m)(4) specified that For mobile digital stations, the attenuation factor shall be not less than $40 + 10 \log (P)$ dB on all frequencies between the channel edge and 5 megahertz from the channel edge, $43 + 10 \log (P)$ dB on all frequencies between 5 megahertz and X megahertz from the channel edge, and $55 + 10 \log (P)$ dB on all frequencies more than X megahertz from the channel edge, where X is the greater of 6 megahertz or the actual emission bandwidth as defined in paragraph (m)(6) of this section. In addition, the attenuation factor shall not be less that $43 + 10 \log (P)$ dB on all frequencies between 2490.5 MHz and 2496 MHz and $55 + 10 \log (P)$ dB at or below 2490.5 MHz. Mobile Satellite Service licensees operating on frequencies below 2495 MHz may also submit a documented interference complaint against BRS licensees operating on channel BRS Channel 1 on the same terms and conditions as adjacent channel BRS or EBS licensees. For mobile digital stations, in the 1 megahertz bands immediately outside and adjacent to the frequency block a resolution bandwidth of at least two percent may be employed.

3.4.2 TEST SETUP

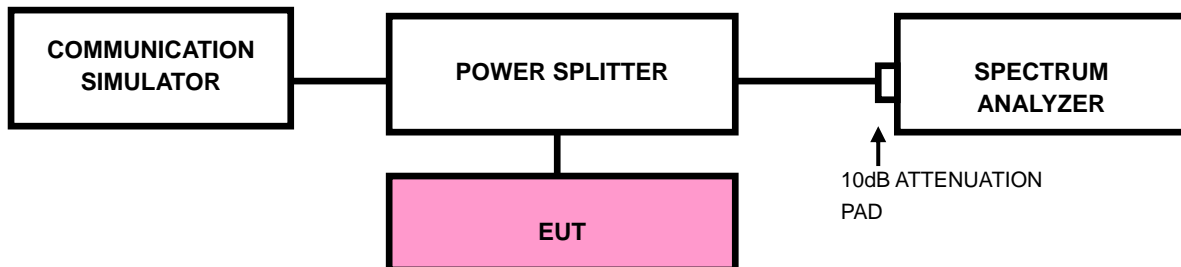



3.4.3 TEST PROCEDURES

- a. The EUT was set up for the maximum peak power with LTE link data modulation. The power was measured with R&S Spectrum Analyzer. All measurements were done at 2 channels (low and high operational frequency range.).
- b. The band edge measurement used the power splitter via EUT RF power connector between simulation base station and spectrum analyzer.
- c. The center frequency of spectrum is the band edge frequency and span is 10MHz. RBW of the spectrum is 100kHz and VBW of the spectrum is 300kHz (WCDMA).
- d. The center frequency of spectrum is the band edge frequency and span is 1~5 MHz. RBW of the spectrum is 20kHz and VBW of the spectrum is 100 kHz. (LTE bandwidth 1.4MHz)
- e. The center frequency of spectrum is the band edge frequency and span is 1~5 MHz. RBW of the spectrum is 30kHz and VBW of the spectrum is 100kHz. (LTE bandwidth 3MHz)
- f. The center frequency of spectrum is the band edge frequency and span is 1~5 MHz. RBW of the spectrum is 50kHz and VBW of the spectrum is 200kHz. (LTE bandwidth 5MHz)
- g. The center frequency of spectrum is the band edge frequency and span is 1~5 MHz. RBW of the spectrum is 100kHz and VBW of the spectrum is 300kHz. (LTE bandwidth 10MHz)
- h. The center frequency of spectrum is the band edge frequency and span is 1~5 MHz. RBW of the spectrum is 150kHz and VBW of the spectrum is 1MHz. (LTE bandwidth 15MHz)
- i. The center frequency of spectrum is the band edge frequency and span is 1~5 MHz. RBW of the spectrum is 200kHz and VBW of the spectrum is 1MHz. (LTE bandwidth 20MHz)
- j. Record the max trace plot into the test report.



Test Report No.: W7L-P21090006RF07

3.4.4 TEST RESULTS

NOTE: N/A refer to original report RF180521W014-3

3.5 CONDUCTED SPURIOUS EMISSIONS

3.5.1 LIMITS OF CONDUCTED SPURIOUS EMISSIONS MEASUREMENT

The power of any emission outside a licensee's frequency block shall be attenuated below the transmitter power (P) by at least $55 + 10 \log_{10}(P)$ dB. The limit of emission is equal to -25dBm.

3.5.2 TEST PROCEDURE

- a. The EUT makes a phone call to the communication simulator. All measurements were done at low, middle and high operational frequency range.
- b. Measuring frequency range is from 30MHz~27GHz for LTE Band 7 & 30MHz~26.2GHz for LTE Band 38, 30MHz~27GHz for LTE Band 41. 10dB attenuation pad is connected with spectrum. RBW=1MHz and VBW=3MHz are used for conducted emission measurement.

3.5.3 TEST SETUP

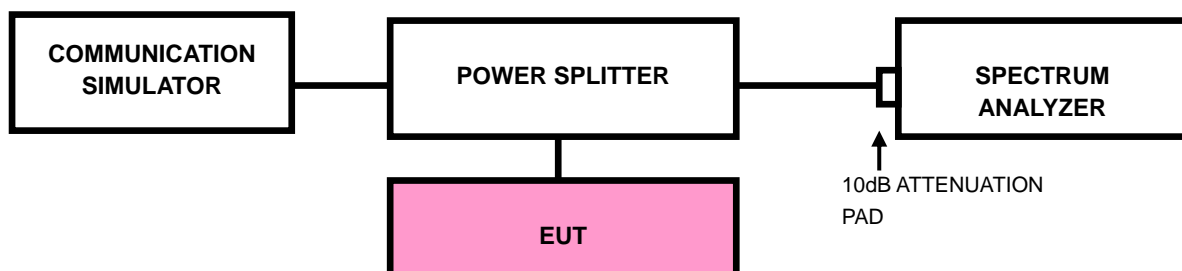



**BUREAU
VERITAS**

Test Report No.: W7L-P21090006RF07

3.5.4 TEST RESULTS

NOTE: N/A refer to original report RF180521W014-3



3.6 RADIATED EMISSION MEASUREMENT

3.6.1 LIMITS OF RADIATED EMISSION MEASUREMENT

The power of any emission outside a licensee's frequency block shall be attenuated below the transmitter power (P) by at least $55 + 10 \log_{10}(P)$ dB. The limit of emission is equal to -25dBm.

3.6.2 TEST PROCEDURES

- a. Substitution method is used for E.I.R.P measurement. In the semi-anechoic chamber, EUT placed on the 0.8m height of Turn Table, rotated the table around 360 degrees to search the maximum radiation power and receiver antenna shall be rotated vertical and horizontal polarization and moved height from 1m to 4m to find the maximum polar radiated power. The "Read Value" is the spectrum reading the maximum power value.
- b. The substitution horn antenna is substituted for EUT at the same position and signals generator export the CW signal to the substitution antenna via a TX cable. Rotated the Turn Table and moved receiving antenna to find the maximum radiation power. Adjust output power level of S.G to get a Value of spectrum reading equal to "Read Value " of step a. Record the power level of S.G.
- c. $EIRP = \text{Output power level of S.G} - \text{TX cable loss} + \text{Antenna gain of substitution horn}$.
- d. E.R.P power can be calculated form E.I.R.P power by subtracting the gain of dipole, $E.R.P \text{ power} = E.I.P.R \text{ power} - 2.15\text{dBi}$.

NOTE: The resolution bandwidth of spectrum analyzer is 1 MHz and the video bandwidth is 3 MHz.

3.6.3 DEVIATION FROM TEST STANDARD

No deviation

3.6.4 TEST SETUP

< Frequency Range 30MHz~1GHz >

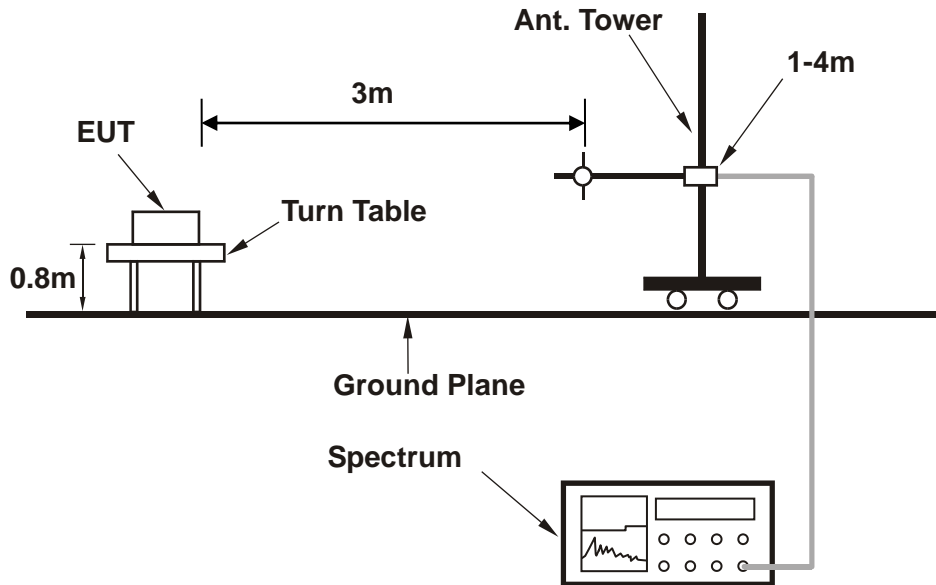

<Frequency Range above 1GHz>

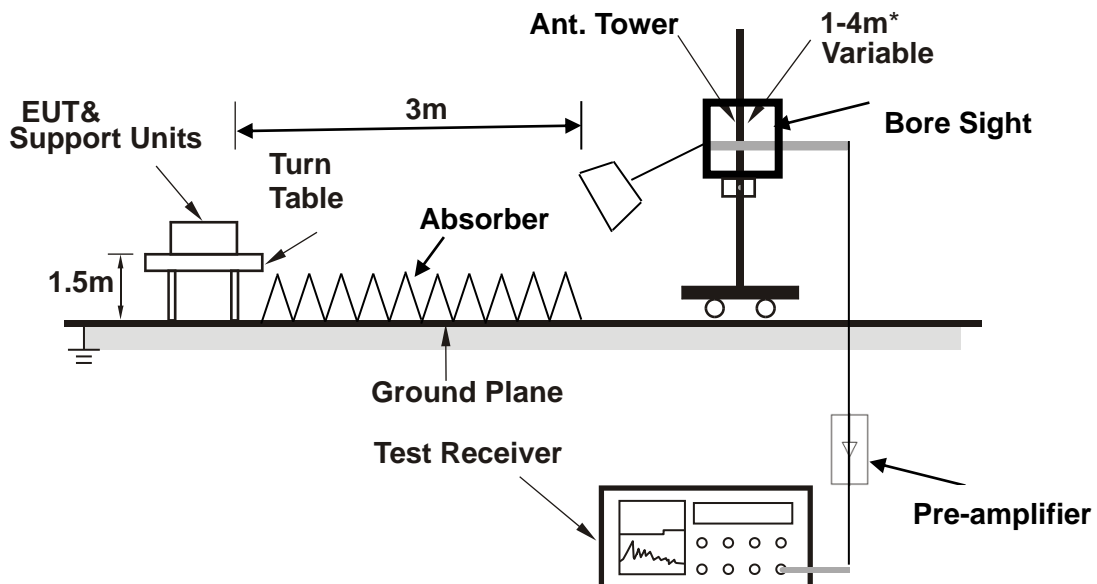

Note: Above 1G is a directional antenna depends on the EUT height and the antenna 3dB beamwidth both, refer to section 7.3 of CISPR 16-2-3.

For the actual test configuration, please refer to the attached file (Test Setup Photo).



3.6.5 TEST RESULTS

BELOW 1GHz WORST-CASE DATA

30 MHz – 1GHz data:

LTE Band 4

CHANNEL BANDWIDTH: 5MHz / QPSK

MODE	TX channel 19975	FREQUENCY RANGE	Below 1000MHz
ENVIRONMENTAL CONDITIONS	23deg. C, 70%RH	INPUT POWER	AC 120V/60Hz
TESTED BY	Jace Hu		
ANTENNA POLARITY & TEST DISTANCE: HORIZONTAL AT 3 M			

	Freq	Level	Read Level	Limit Line	Over Limit	Factor	Remark	Pol/Phase
	MHz	dBm/m	dBm	dBm/m	dB	dB/m		
1	167.740	-23.09	-33.72	-13.00	-10.09	10.63	Peak	Horizontal
2 PP	240.490	-20.99	-33.77	-13.00	-7.99	12.78	Peak	Horizontal
3	336.520	-23.99	-39.05	-13.00	-10.99	15.06	Peak	Horizontal
4	393.750	-25.90	-42.62	-13.00	-12.90	16.72	Peak	Horizontal
5	491.720	-30.25	-48.80	-13.00	-17.25	18.55	Peak	Horizontal
6	624.610	-29.38	-50.57	-13.00	-16.38	21.19	Peak	Horizontal

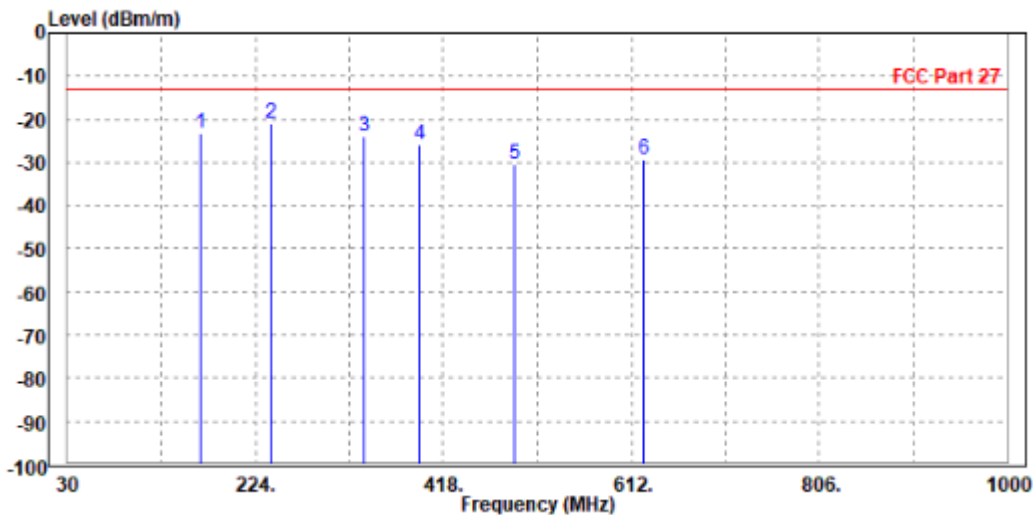



Test Report No.: W7L-P21090006RF07

MODE	TX channel 19975	FREQUENCY RANGE	Below 1000MHz
ENVIRONMENTAL CONDITIONS	23deg. C, 70%RH	INPUT POWER	AC 120V/60Hz
TESTED BY	Jace Hu		
ANTENNA POLARITY & TEST DISTANCE: VERTICAL AT 3 M			

	Freq	Level	Read Level	Limit Line	Over Limit	Factor	Remark	Pol/Phase
	MHz	dBm/m	dBm	dBm/m	dB	dB/m		
1	41.640	-30.05	-41.73	-13.00	-17.05	11.68	Peak	Vertical
2	170.650	-27.52	-38.38	-13.00	-14.52	10.86	Peak	Vertical
3	255.040	-26.76	-40.68	-13.00	-13.76	13.92	Peak	Vertical
4 PP	395.690	-25.97	-43.08	-13.00	-12.97	17.11	Peak	Vertical
5	485.900	-28.69	-47.52	-13.00	-15.69	18.83	Peak	Vertical
6	734.220	-30.04	-52.61	-13.00	-17.04	22.57	Peak	Vertical

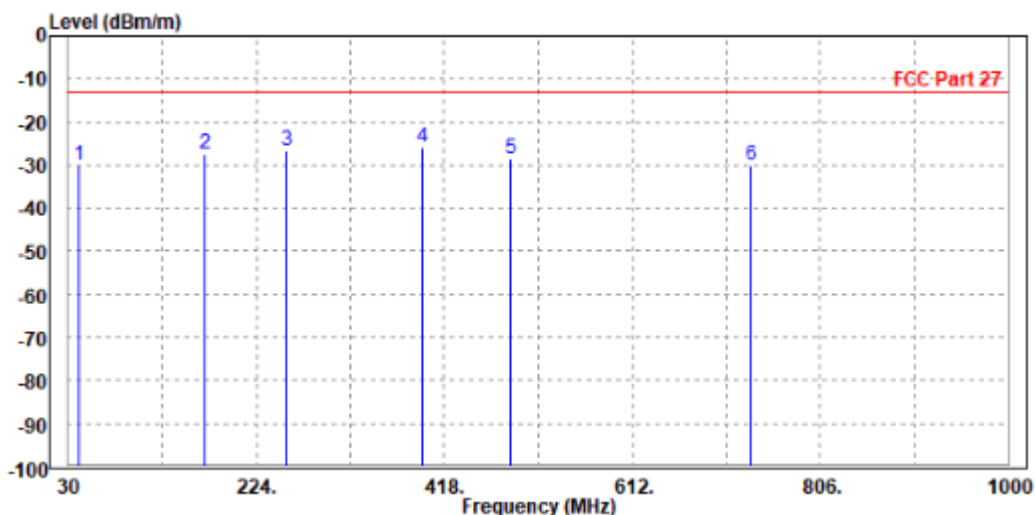



BUREAU VERITAS

Test Report No.: W7L-P21090006RF07

ABOVE 1GHz

Note: For higher frequency, the emission is too low to be detected.

WORST-CASE DATA

LTE Band 4

CHANNEL BANDWIDTH: 1.4MHz / QPSK

CH 20175

MODE	TX channel 20175	FREQUENCY RANGE	Above 1000MHz
ENVIRONMENTAL CONDITIONS	23deg. C, 70%RH	INPUT POWER	AC 120V/60Hz
TESTED BY	Jace Hu		
ANTENNA POLARITY & TEST DISTANCE: HORIZONTAL AT 3 M			

	Freq	Level	Read Level	Limit Line	Over Limit	Factor	Remark	Pol/Phase
	MHz	dBm/m	dBm	dBm/m	dB	dB/m		
1	PP 3465.000	-47.94	-56.52	-13.00	-34.94	8.58	Peak	Horizontal
2	5186.000	-49.56	-58.64	-13.00	-36.56	9.08	Peak	Horizontal

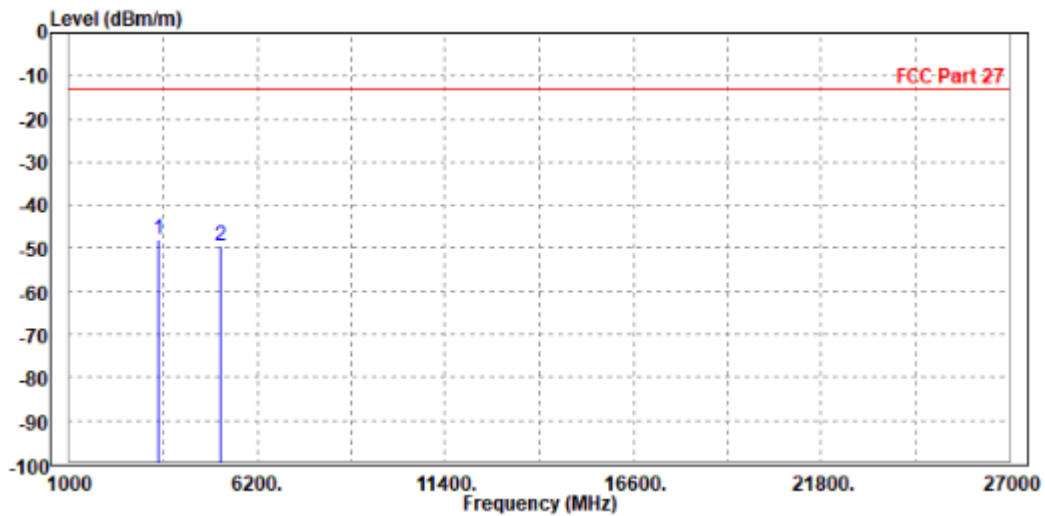



Test Report No.: W7L-P21090006RF07

MODE	TX channel 20175	FREQUENCY RANGE	Above 1000MHz
ENVIRONMENTAL CONDITIONS	23deg. C, 70%RH	INPUT POWER	AC 120V/60Hz
TESTED BY	Jace Hu		
ANTENNA POLARITY & TEST DISTANCE: VERTICAL AT 3 M			

	Freq	Level	Read Level	Limit Line	Over Limit	Factor	Remark	Pol/Phase
	MHz	dBm/m	dBm	dBm/m	dB	dB/m		
1	3470.000	-47.13	-56.29	-13.00	-34.13	9.16	Peak	Vertical
2 PP	5197.500	-46.53	-56.35	-13.00	-33.53	9.82	Peak	Vertical

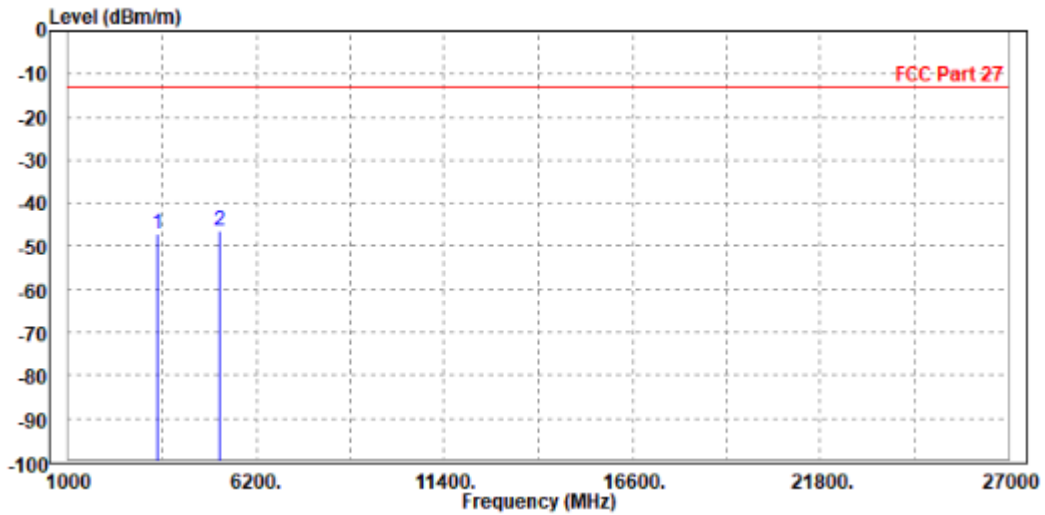



**BUREAU
VERITAS**

Test Report No.: W7L-P21090006RF07

CHANNEL BANDWIDTH: 3MHz / QPSK

CH 20175

MODE	TX channel 20175	FREQUENCY RANGE	Above 1000MHz
ENVIRONMENTAL CONDITIONS	23deg. C, 70%RH	INPUT POWER	AC 120V/60Hz
TESTED BY	Jace Hu		
ANTENNA POLARITY & TEST DISTANCE: HORIZONTAL AT 3 M			

	Freq	Level	Read Level	Limit Line	Over Limit	Factor	Remark	Pol/Phase
	MHz	dBm/m	dBm	dBm/m	dB	dB/m		
1	PP 3470.000	-47.29	-55.87	-13.00	-34.29	8.58	Peak	Horizontal
2	5197.500	-47.44	-56.56	-13.00	-34.44	9.12	Peak	Horizontal

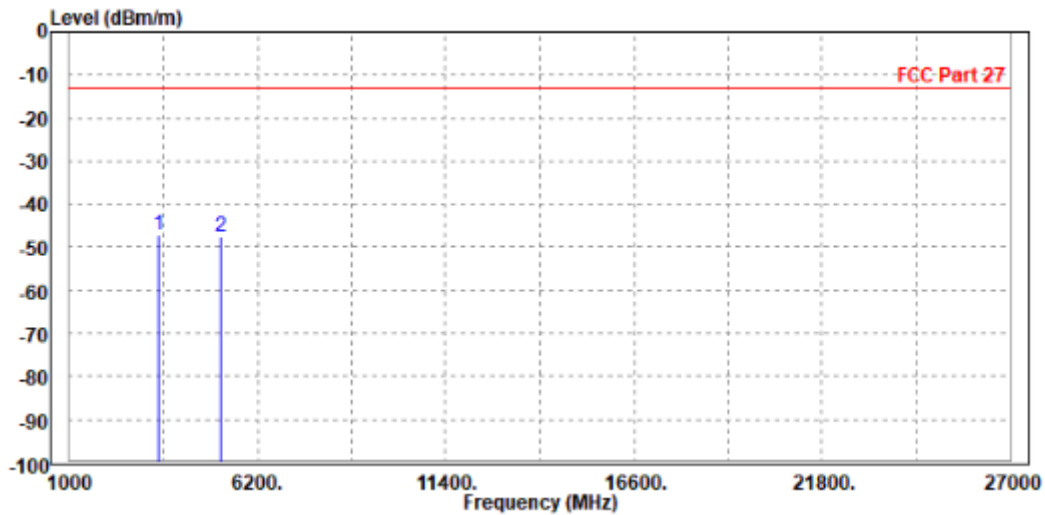



Test Report No.: W7L-P21090006RF07

MODE	TX channel 20175	FREQUENCY RANGE	Above 1000MHz
ENVIRONMENTAL CONDITIONS	23deg. C, 70%RH	INPUT POWER	AC 120V/60Hz
TESTED BY	Jace Hu		
ANTENNA POLARITY & TEST DISTANCE: VERTICAL AT 3 M			

	Freq	Level	Read Level	Limit Line	Over Limit	Factor	Remark	Pol/Phase
	MHz	dBm/m	dBm	dBm/m	dB	dB/m		
1	3465.000	-46.41	-55.57	-13.00	-33.41	9.16	Peak	Vertical
2 PP	5186.000	-44.57	-54.40	-13.00	-31.57	9.83	Peak	Vertical

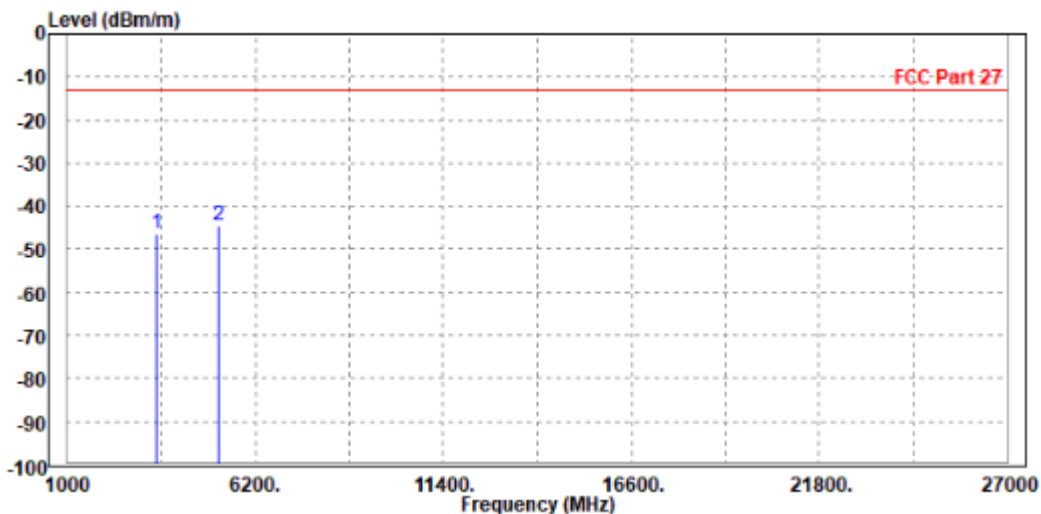



BUREAU VERITAS

Test Report No.: W7L-P21090006RF07

CHANNEL BANDWIDTH: 5MHz / QPSK

CH 19975

MODE	TX channel 19975	FREQUENCY RANGE	Above 1000MHz
ENVIRONMENTAL CONDITIONS	23deg. C, 70%RH	INPUT POWER	AC 120V/60Hz
TESTED BY	Jace Hu		
ANTENNA POLARITY & TEST DISTANCE: HORIZONTAL AT 3 M			

	Freq	Level	Read Level	Limit Line	Over Limit	Factor	Remark	Pol/Phase
	MHz	dBm/m	dBm	dBm/m	dB	dB/m		
1	PP 3425.000	-47.66	-56.25	-13.00	-34.66	8.59	Peak	Horizontal
2	5134.000	-48.84	-57.77	-13.00	-35.84	8.93	Peak	Horizontal

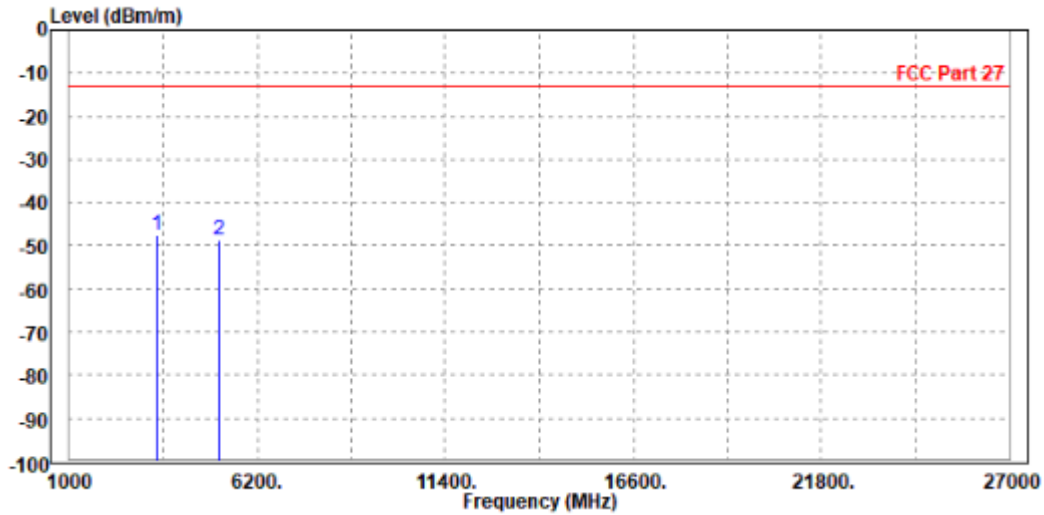



Test Report No.: W7L-P21090006RF07

MODE	TX channel 19975	FREQUENCY RANGE	Above 1000MHz
ENVIRONMENTAL CONDITIONS	23deg. C, 70%RH	INPUT POWER	AC 120V/60Hz
TESTED BY	Jace Hu		
ANTENNA POLARITY & TEST DISTANCE: VERTICAL AT 3 M			

	Freq	Level	Read Level	Limit Line	Over Limit	Factor	Remark	Pol/Phase
	MHz	dBm/m	dBm	dBm/m	dB	dB/m		
1	PP 3418.000	-45.42	-54.53	-13.00	-32.42	9.11	Peak	Vertical
2	5137.500	-47.81	-57.66	-13.00	-34.81	9.85	Peak	Vertical

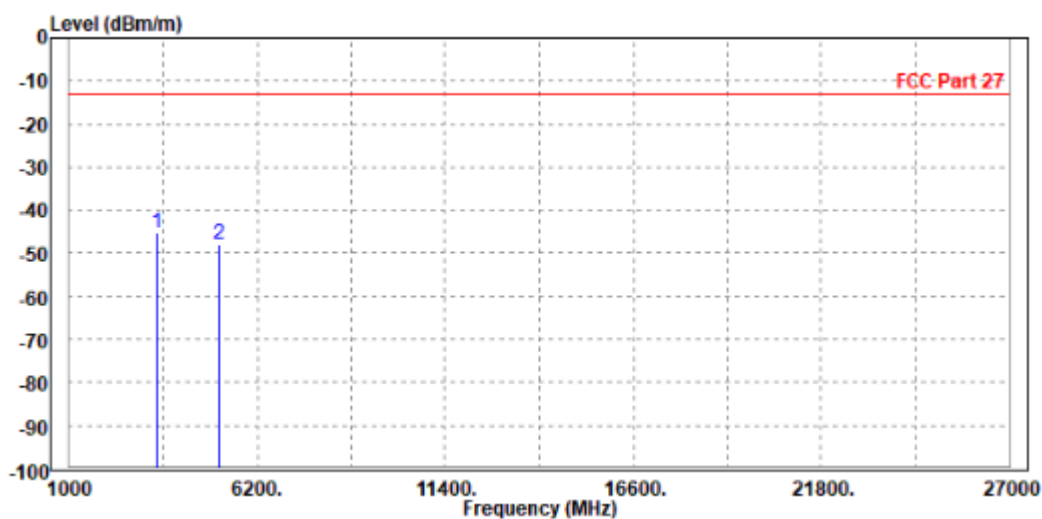



**BUREAU
VERITAS**

Test Report No.: W7L-P21090006RF07

CH 20175

MODE	TX channel 20175	FREQUENCY RANGE	Above 1000MHz
ENVIRONMENTAL CONDITIONS	23deg. C, 70%RH	INPUT POWER	AC 120V/60Hz
TESTED BY	Jace Hu		
ANTENNA POLARITY & TEST DISTANCE: HORIZONTAL AT 3 M			

	Freq	Level	Read Level	Limit Line	Over Limit	Factor	Remark	Pol/Phase
	MHz	dBm/m	dBm	dBm/m	dB	dB/m		
1	3470.000	-48.25	-56.83	-13.00	-35.25	8.58	Peak	Horizontal
2	PP 5197.500	-46.40	-55.52	-13.00	-33.40	9.12	Peak	Horizontal

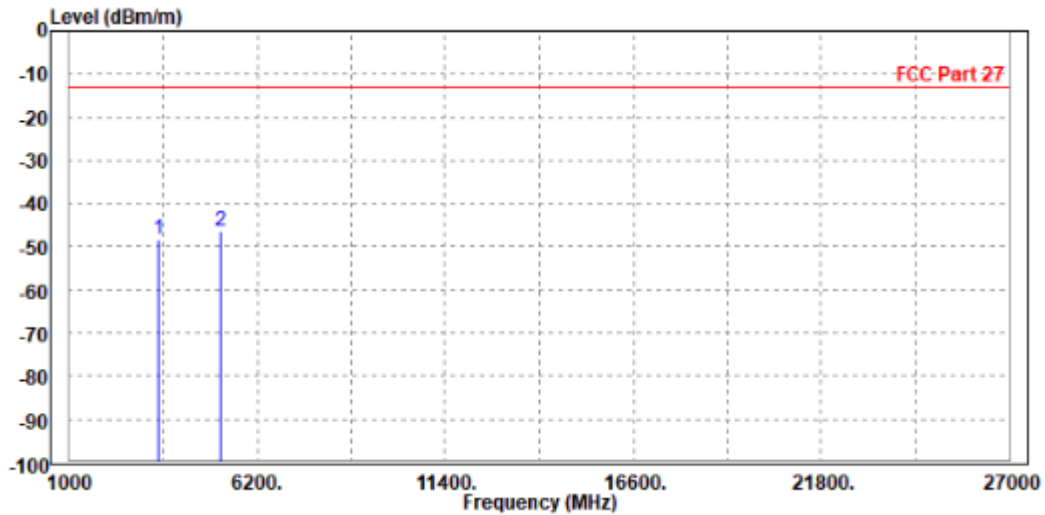



Test Report No.: W7L-P21090006RF07

MODE	TX channel 20175	FREQUENCY RANGE	Above 1000MHz
ENVIRONMENTAL CONDITIONS	23deg. C, 70%RH	INPUT POWER	AC 120V/60Hz
TESTED BY	Jace Hu		
ANTENNA POLARITY & TEST DISTANCE: VERTICAL AT 3 M			

	Freq	Level	Read Level	Limit Line	Over Limit	Factor	Remark	Pol/Phase
	MHz	dBm/m	dBm	dBm/m	dB	dB/m		
1	3465.000	-45.98	-55.14	-13.00	-32.98	9.16	Peak	Vertical
2	PP 5186.000	-44.09	-53.92	-13.00	-31.09	9.83	Peak	Vertical

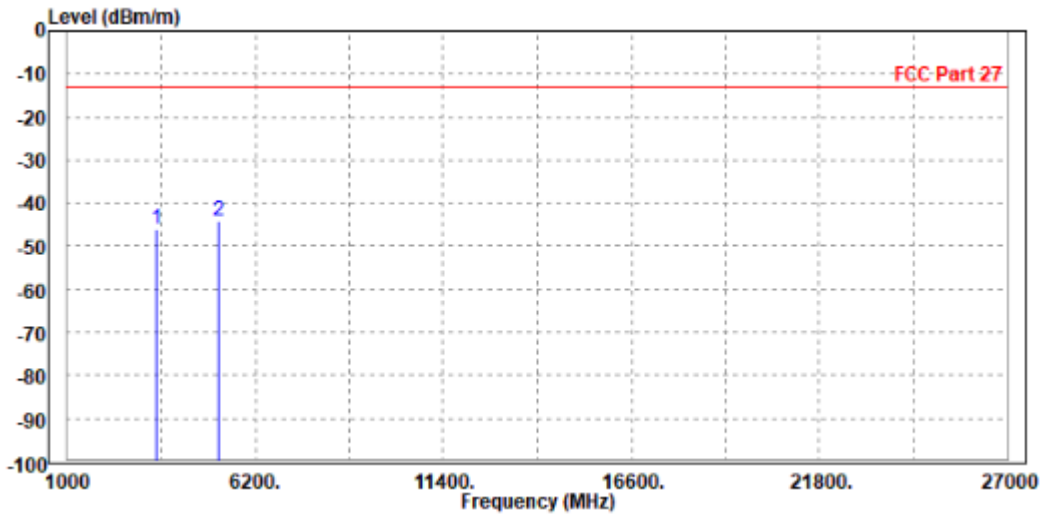



BUREAU VERITAS

Test Report No.: W7L-P21090006RF07

CH 20375

MODE	TX channel 20375	FREQUENCY RANGE	Above 1000MHz
ENVIRONMENTAL CONDITIONS	23deg. C, 70%RH	INPUT POWER	AC 120V/60Hz
TESTED BY	Jace Hu		
ANTENNA POLARITY & TEST DISTANCE: HORIZONTAL AT 3 M			

	Freq	Level	Read Level	Limit Line	Over Limit	Factor	Remark	Pol/Phase
	MHz	dBm/m	dBm	dBm/m	dB	dB/m		
1	PP 3496.000	-42.56	-51.13	-13.00	-29.56	8.57	Peak	Horizontal
2	5257.500	-49.44	-58.74	-13.00	-36.44	9.30	Peak	Horizontal

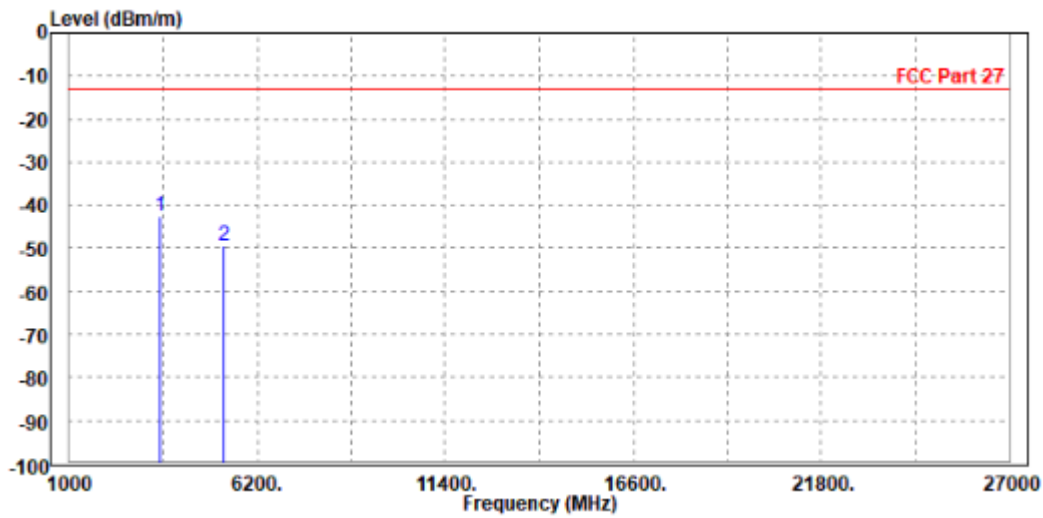



BUREAU VERITAS

Test Report No.: W7L-P21090006RF07

MODE	TX channel 20375	FREQUENCY RANGE	Above 1000MHz
ENVIRONMENTAL CONDITIONS	23deg. C, 70%RH	INPUT POWER	AC 120V/60Hz
TESTED BY	Jace Hu		
ANTENNA POLARITY & TEST DISTANCE: VERTICAL AT 3 M			

	Freq	Level	Read Level	Limit Line	Over Limit	Factor	Remark	Pol/Phase
	MHz	dBm/m	dBm	dBm/m	dB	dB/m		
1	PP 3496.000	-37.31	-46.50	-13.00	-24.31	9.19	Peak	Vertical
2	5257.500	-47.81	-57.61	-13.00	-34.81	9.80	Peak	Vertical

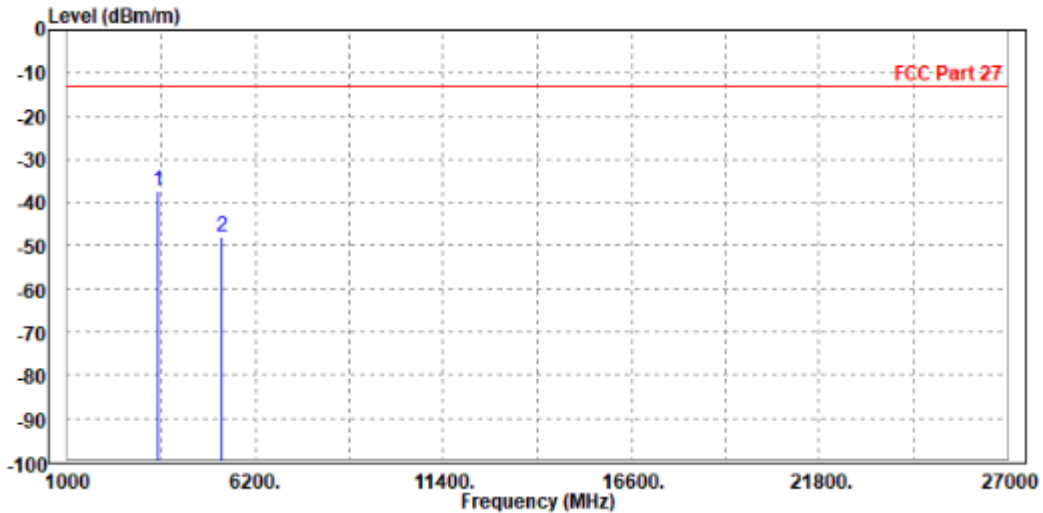



BUREAU VERITAS

Test Report No.: W7L-P21090006RF07

CHANNEL BANDWIDTH: 10MHz / QPSK

MODE	TX channel 20175	FREQUENCY RANGE	Above 1000MHz
ENVIRONMENTAL CONDITIONS	23deg. C, 70%RH	INPUT POWER	AC 120V/60Hz
TESTED BY	Jace Hu		
ANTENNA POLARITY & TEST DISTANCE: HORIZONTAL AT 3 M			

	Freq	Level	Read Level	Limit Line	Over Limit	Factor	Remark	Pol/Phase
	MHz	dBm/m	dBm	dBm/m	dB	dB/m		
1	3465.000	-48.52	-57.10	-13.00	-35.52	8.58	Peak	Horizontal
2 PP	5186.000	-46.89	-55.97	-13.00	-33.89	9.08	Peak	Horizontal

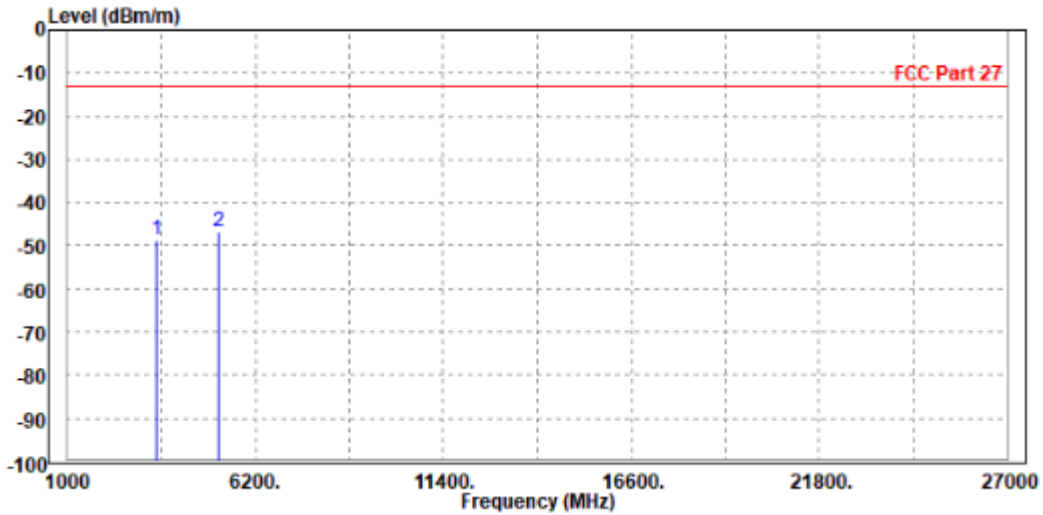



Test Report No.: W7L-P21090006RF07

MODE	TX channel 20175	FREQUENCY RANGE	Above 1000MHz
ENVIRONMENTAL CONDITIONS	23deg. C, 70%RH	INPUT POWER	AC 120V/60Hz
TESTED BY	Jace Hu		
ANTENNA POLARITY & TEST DISTANCE: VERTICAL AT 3 M			

	Freq	Level	Read Level	Limit Line	Over Limit	Factor	Remark	Pol/Phase
	MHz	dBm/m	dBm	dBm/m	dB	dB/m		
1	3470.000	-47.73	-56.89	-13.00	-34.73	9.16	Peak	Vertical
2 PP	5197.500	-44.10	-53.92	-13.00	-31.10	9.82	Peak	Vertical

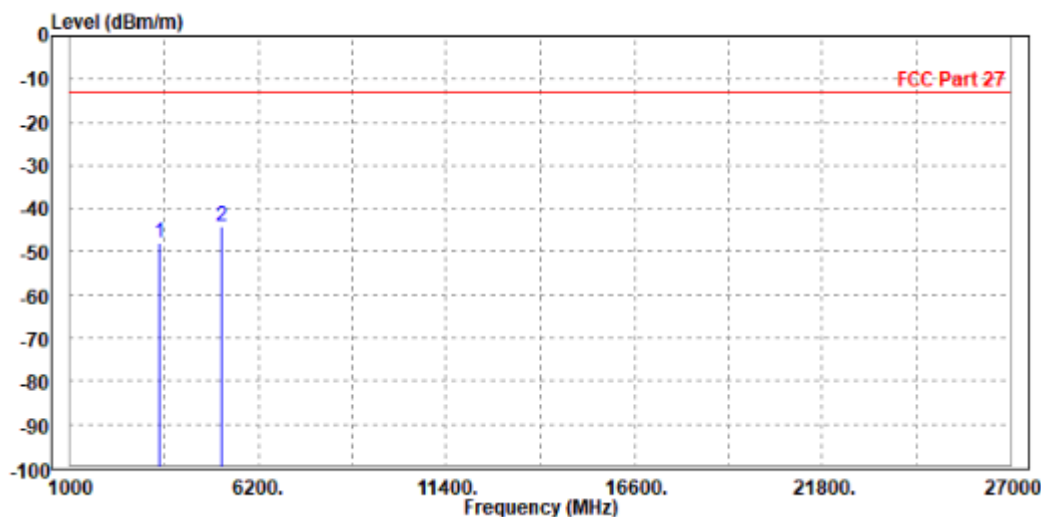



**BUREAU
VERITAS**

Test Report No.: W7L-P21090006RF07

CHANNEL BANDWIDTH: 15MHz / QPSK

CH20175

MODE	TX channel 20175	FREQUENCY RANGE	Above 1000MHz
ENVIRONMENTAL CONDITIONS	23deg. C, 70%RH	INPUT POWER	AC 120V/60Hz
TESTED BY	Jace Hu		
ANTENNA POLARITY & TEST DISTANCE: HORIZONTAL AT 3 M			

	Freq	Level	Read Level	Limit Line	Over Limit	Factor	Remark	Pol/Phase
	MHz	dBm/m	dBm	dBm/m	dB	dB/m		
1	3465.000	-47.83	-56.41	-13.00	-34.83	8.58	Peak	Horizontal
2 PP	5186.000	-45.65	-54.73	-13.00	-32.65	9.08	Peak	Horizontal

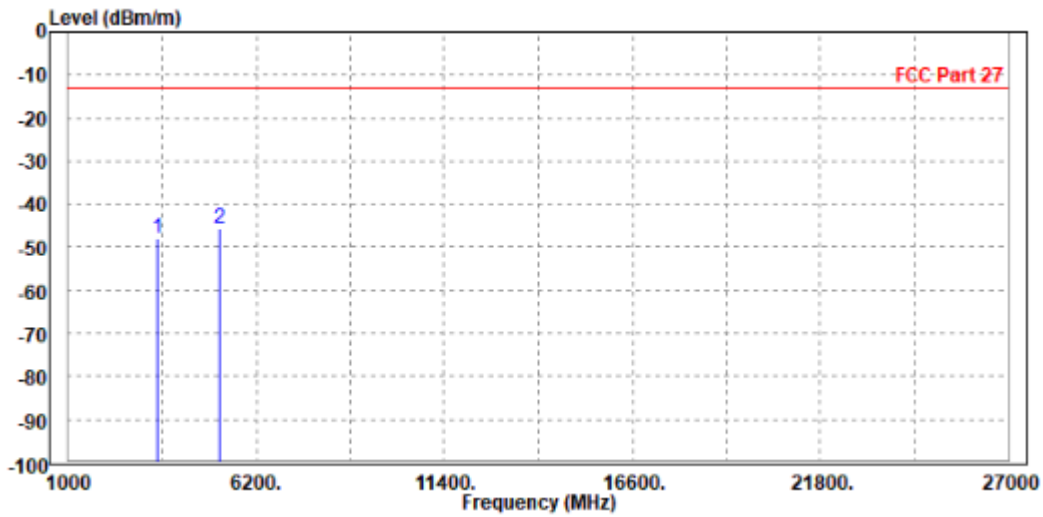



Test Report No.: W7L-P21090006RF07

MODE	TX channel 20175	FREQUENCY RANGE	Above 1000MHz
ENVIRONMENTAL CONDITIONS	23deg. C, 70%RH	INPUT POWER	AC 120V/60Hz
TESTED BY	Jace Hu		
ANTENNA POLARITY & TEST DISTANCE: VERTICAL AT 3 M			

	Freq	Level	Read Level	Limit Line	Over Limit	Factor	Remark	Pol/Phase
	MHz	dBm/m	dBm	dBm/m	dB	dB/m		
1	3470.000	-47.29	-56.45	-13.00	-34.29	9.16	Peak	Vertical
2 PP	5197.500	-45.89	-55.71	-13.00	-32.89	9.82	Peak	Vertical

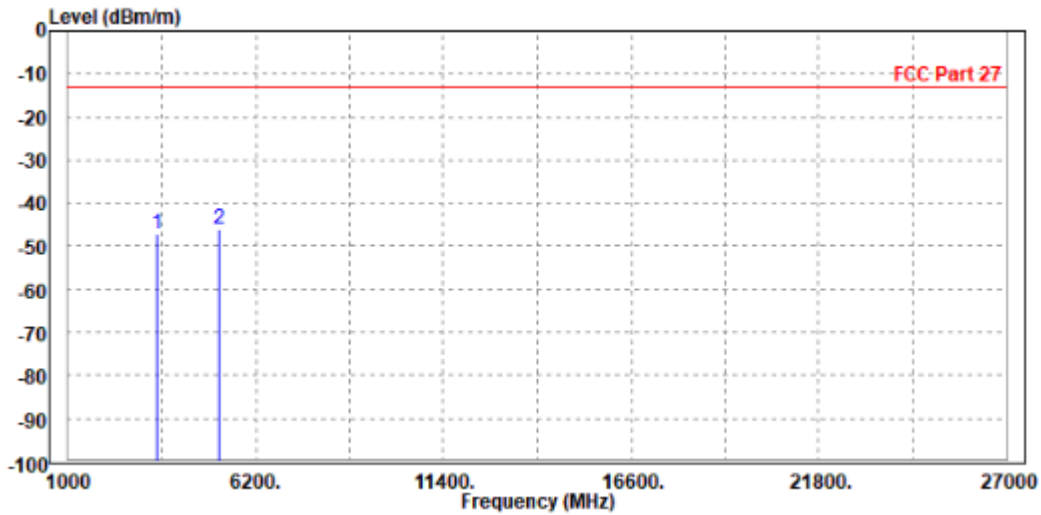



BUREAU
VERITAS

Test Report No.: W7L-P21090006RF07

CHANNEL BANDWIDTH: 20MHz / QPSK

CH 20175

MODE	TX channel 20175	FREQUENCY RANGE	Above 1000MHz
ENVIRONMENTAL CONDITIONS	23deg. C, 70%RH	INPUT POWER	AC 120V/60Hz
TESTED BY	Jace Hu		
ANTENNA POLARITY & TEST DISTANCE: HORIZONTAL AT 3 M			

	Freq	Level	Read Level	Limit Line	Over Limit	Factor	Remark	Pol/Phase
	MHz	dBm/m	dBm	dBm/m	dB	dB/m		
1	3470.000	-48.11	-56.69	-13.00	-35.11	8.58	Peak	Horizontal
2 PP	5197.500	-47.20	-56.32	-13.00	-34.20	9.12	Peak	Horizontal

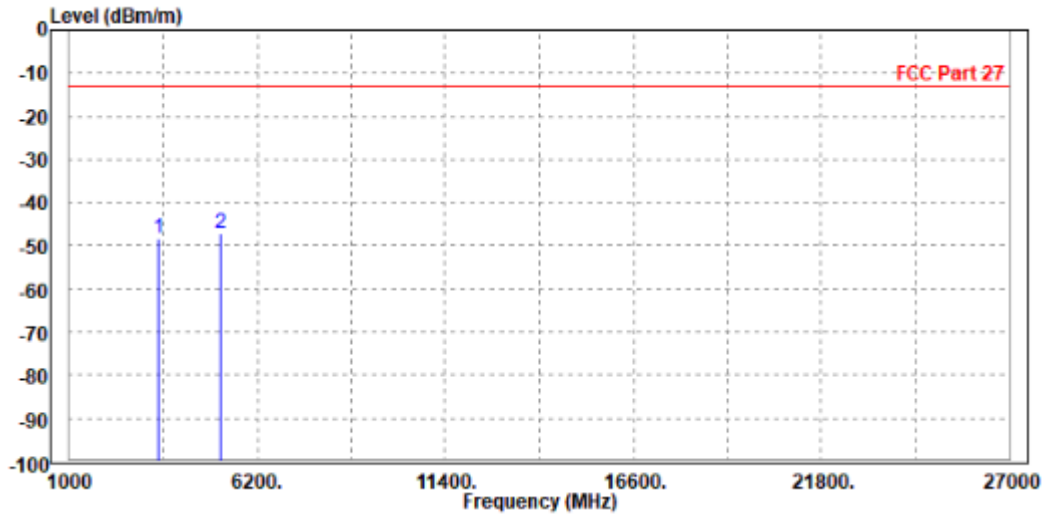



Test Report No.: W7L-P21090006RF07

MODE	TX channel 20175	FREQUENCY RANGE	Above 1000MHz
ENVIRONMENTAL CONDITIONS	23deg. C, 70%RH	INPUT POWER	AC 120V/60Hz
TESTED BY	Jace Hu		
ANTENNA POLARITY & TEST DISTANCE: VERTICAL AT 3 M			

	Freq	Level	Read Level	Limit Line	Over Limit	Factor	Remark	Pol/Phase
	MHz	dBm/m	dBm	dBm/m	dB	dB/m		
1	PP 3465.000	-47.44	-56.60	-13.00	-34.44	9.16	Peak	Vertical
2	5186.000	-48.45	-58.28	-13.00	-35.45	9.83	Peak	Vertical

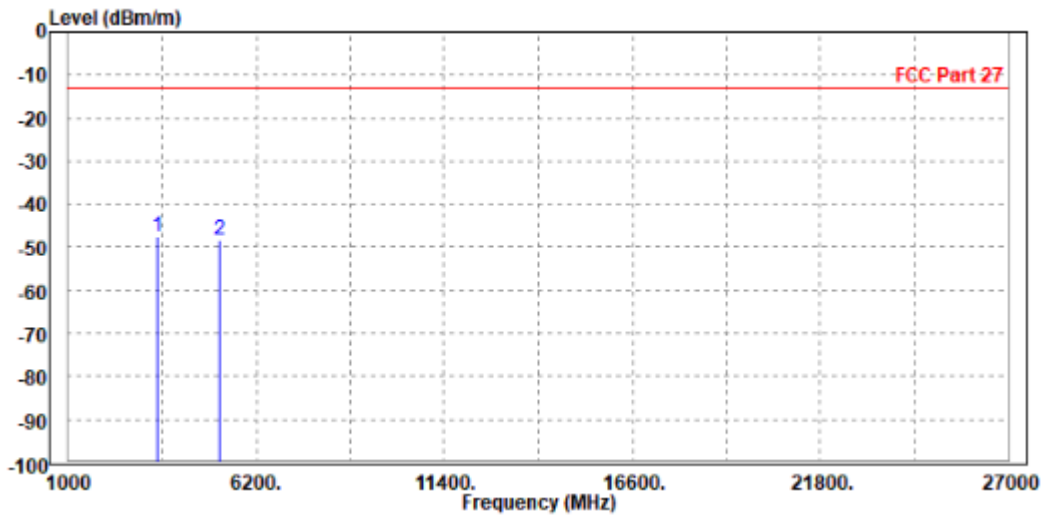



Test Report No.: W7L-P21090006RF07

LTE BAND 12

CHANNEL BANDWIDTH: 1.4MHz / QPSK

MODE	TX channel 23095	FREQUENCY RANGE	Above 1000MHz
ENVIRONMENTAL CONDITIONS	23deg. C, 70%RH	INPUT POWER	AC 120V/60Hz
TESTED BY	Jace Hu		
ANTENNA POLARITY & TEST DISTANCE: HORIZONTAL AT 3 M			

	Freq	Level	Read Level	Limit Line	Over Limit	Factor	Remark	Pol/Phase
	MHz	dBm/m	dBm	dBm/m	dB	dB/m		
1	1416.000	-52.93	-54.01	-13.00	-39.93	1.08	Peak	Horizontal
2 PP	2122.500	-42.51	-50.18	-13.00	-29.51	7.67	Peak	Horizontal

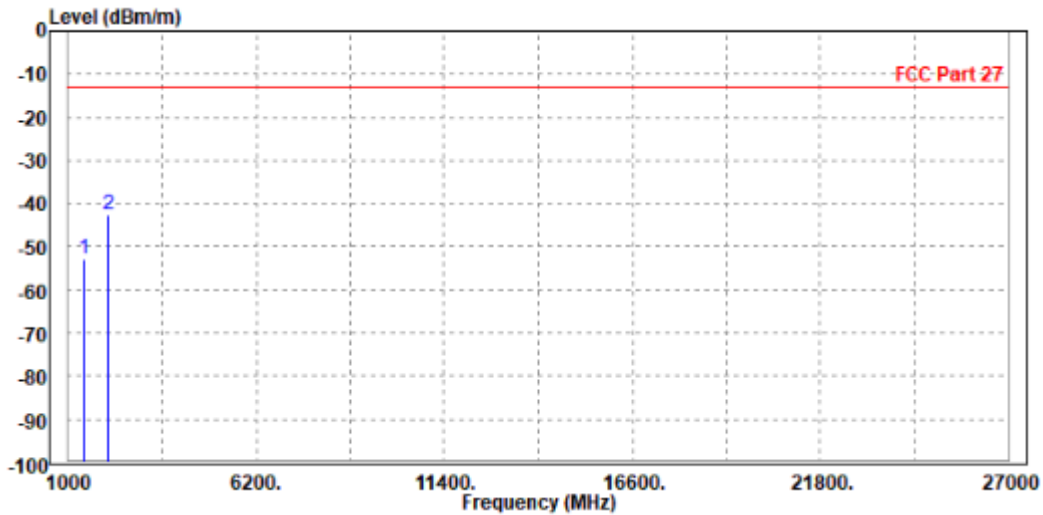



Test Report No.: W7L-P21090006RF07

MODE	TX channel 23095	FREQUENCY RANGE	Above 1000MHz
ENVIRONMENTAL CONDITIONS	23deg. C, 70%RH	INPUT POWER	AC 120V/60Hz
TESTED BY	Jace Hu		
ANTENNA POLARITY & TEST DISTANCE: VERTICAL AT 3 M			

	Freq	Level	Read Level	Limit Line	Over Limit	Factor	Remark	Pol/Phase
	MHz	dBm/m	dBm	dBm/m	dB	dB/m		
1	1415.000	-50.96	-52.65	-13.00	-37.96	1.69	Peak	Vertical
2 PP	2118.000	-43.68	-50.36	-13.00	-30.68	6.68	Peak	Vertical

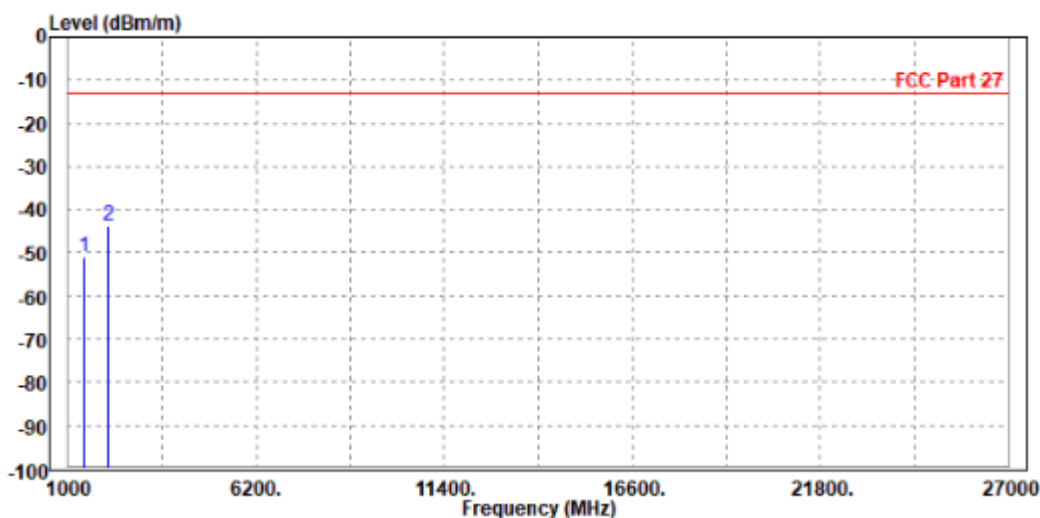



BUREAU
VERITAS

Test Report No.: W7L-P21090006RF07

CHANNEL BANDWIDTH: 3MHz / QPSK

CH23095

MODE	TX channel 23095	FREQUENCY RANGE	Above 1000MHz
ENVIRONMENTAL CONDITIONS	23deg. C, 70%RH	INPUT POWER	AC 120V/60Hz
TESTED BY	Jace Hu		
ANTENNA POLARITY & TEST DISTANCE: HORIZONTAL AT 3 M			

	Freq	Level	Read Level	Limit Line	Over Limit	Factor	Remark	Pol/Phase
	MHz	dBm/m	dBm	dBm/m	dB	dB/m		
1	1416.000	-41.51	-42.59	-13.00	-28.51	1.08	Peak	Horizontal
2	PP 2118.000	-38.77	-46.44	-13.00	-25.77	7.67	Peak	Horizontal

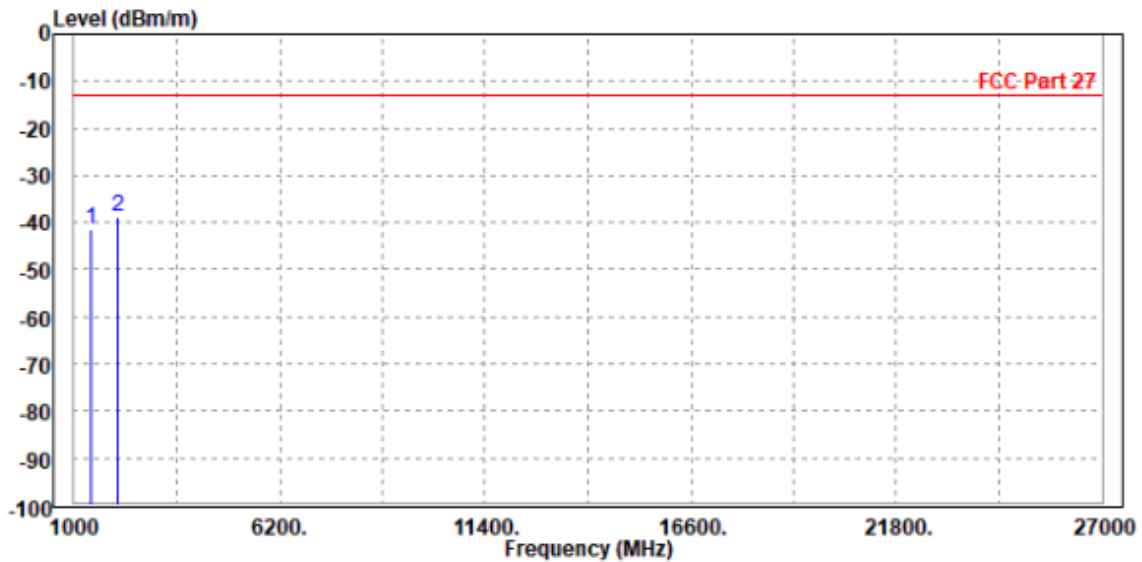



Test Report No.: W7L-P21090006RF07

MODE	TX channel 23095	FREQUENCY RANGE	Above 1000MHz
ENVIRONMENTAL CONDITIONS	23deg. C, 70%RH	INPUT POWER	AC 120V/60Hz
TESTED BY	Jace Hu		
ANTENNA POLARITY & TEST DISTANCE: VERTICAL AT 3 M			

	Freq	Level	Read Level	Limit Line	Over Limit	Factor	Remark	Pol/Phase
	MHz	dBm/m	dBm	dBm/m	dB	dB/m		
1	PP 1415.000	-40.90	-42.59	-13.00	-27.90	1.69	Peak	Vertical
2	2118.000	-41.70	-48.38	-13.00	-28.70	6.68	Peak	Vertical

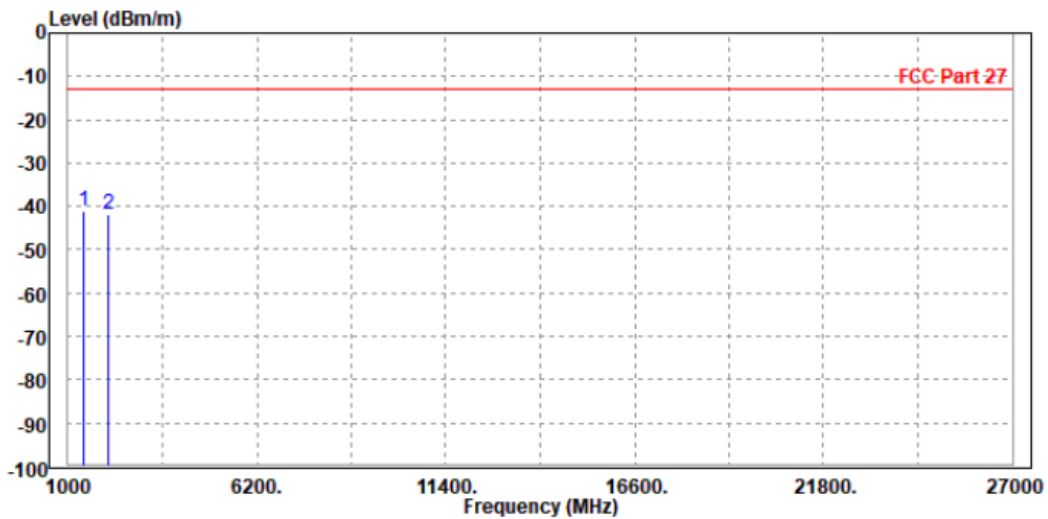



Test Report No.: W7L-P21090006RF07

CHANNEL BANDWIDTH: 5MHz / QPSK

MODE	TX channel 23095	FREQUENCY RANGE	Above 1000MHz
ENVIRONMENTAL CONDITIONS	23deg. C, 70%RH	INPUT POWER	AC 120V/60Hz
TESTED BY	Jace Hu		
ANTENNA POLARITY & TEST DISTANCE: HORIZONTAL AT 3 M			

	Freq	Level	Read Level	Limit Line	Over Limit	Factor	Remark	Pol/Phase
	MHz	dBm/m	dBm	dBm/m	dB	dB/m		
1	1416.000	-44.85	-45.93	-13.00	-31.85	1.08	Peak	Horizontal
2 PP	2118.000	-41.55	-49.22	-13.00	-28.55	7.67	Peak	Horizontal

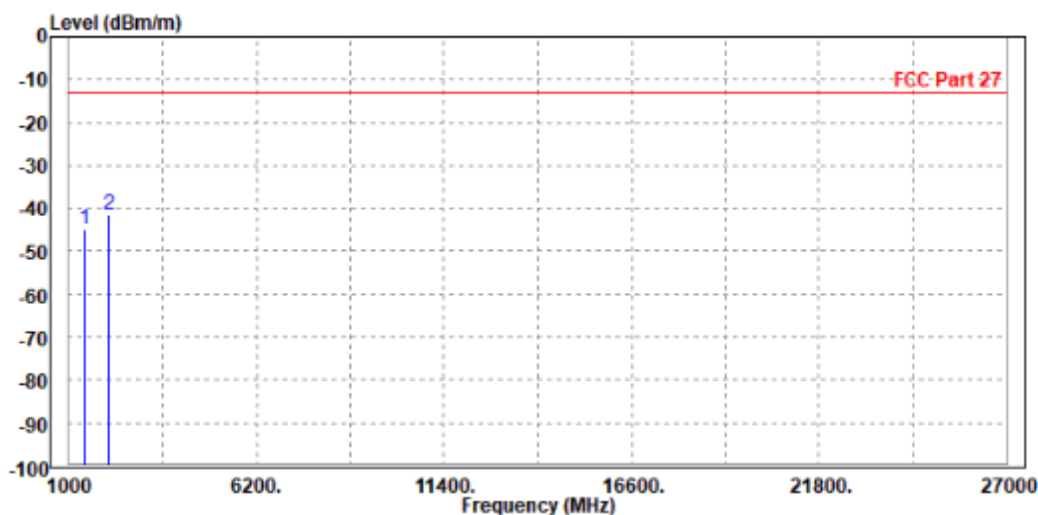



Test Report No.: W7L-P21090006RF07

MODE	TX channel 23095	FREQUENCY RANGE	Above 1000MHz
ENVIRONMENTAL CONDITIONS	23deg. C, 70%RH	INPUT POWER	AC 120V/60Hz
TESTED BY	Jace Hu		
ANTENNA POLARITY & TEST DISTANCE: VERTICAL AT 3 M			

	Freq	Level	Read Level	Limit Line	Over Limit	Factor	Remark	Pol/Phase
	MHz	dBm/m	dBm	dBm/m	dB	dB/m		
1	PP 1416.000	-42.63	-44.32	-13.00	-29.63	1.69	Peak	Vertical
2	2122.500	-43.77	-50.46	-13.00	-30.77	6.69	Peak	Vertical

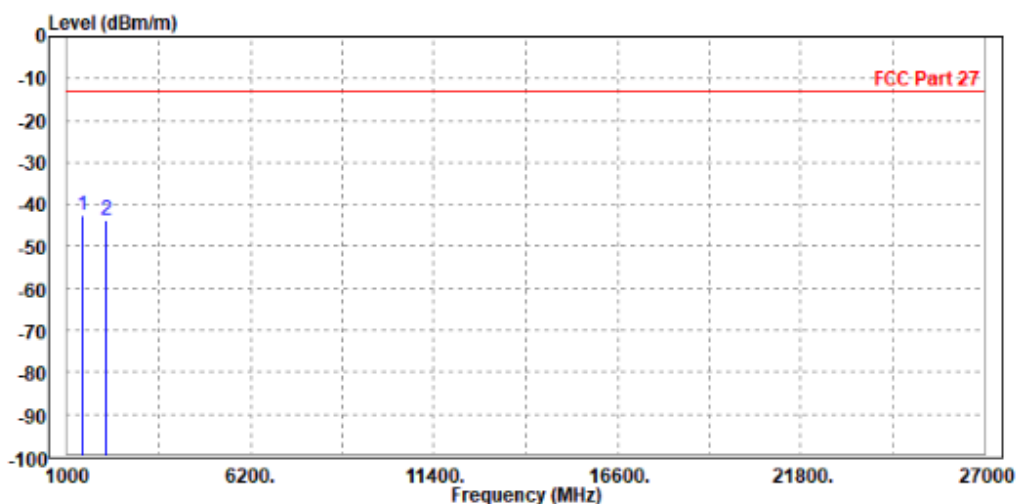



Test Report No.: W7L-P21090006RF07

CHANNEL BANDWIDTH: 10MHz / QPSK

CH23060

MODE	TX channel 23060	FREQUENCY RANGE	Above 1000MHz
ENVIRONMENTAL CONDITIONS	23deg. C, 70%RH	INPUT POWER	AC 120V/60Hz
TESTED BY	Jace Hu		
ANTENNA POLARITY & TEST DISTANCE: HORIZONTAL AT 3 M			

	Freq	Level	Read Level	Limit	Over Limit	Factor	Remark	Pol/Phase
	MHz	dBm/m	dBm	dBm/m	dB	dB/m		
1	1416.000	-51.64	-52.72	-13.00	-38.64	1.08	Peak	Horizontal
2	PP 2112.000	-42.37	-50.03	-13.00	-29.37	7.66	Peak	Horizontal

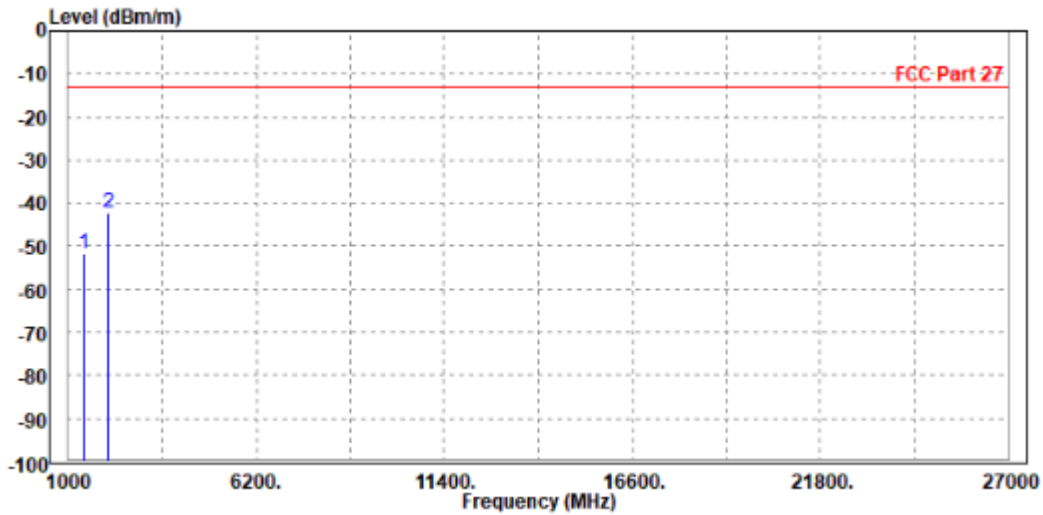



Test Report No.: W7L-P21090006RF07

MODE	TX channel 23060	FREQUENCY RANGE	Above 1000MHz
ENVIRONMENTAL CONDITIONS	23deg. C, 70%RH	INPUT POWER	AC 120V/60Hz
TESTED BY	Jace Hu		
ANTENNA POLARITY & TEST DISTANCE: VERTICAL AT 3 M			

	Freq	Level	Read Level	Limit Line	Over Limit	Factor	Remark	Pol/Phase
	MHz	dBm/m	dBm	dBm/m	dB	dB/m		
1	1416.000	-51.88	-53.57	-13.00	-38.88	1.69	Peak	Vertical
2 PP	2112.000	-43.25	-49.93	-13.00	-30.25	6.68	Peak	Vertical

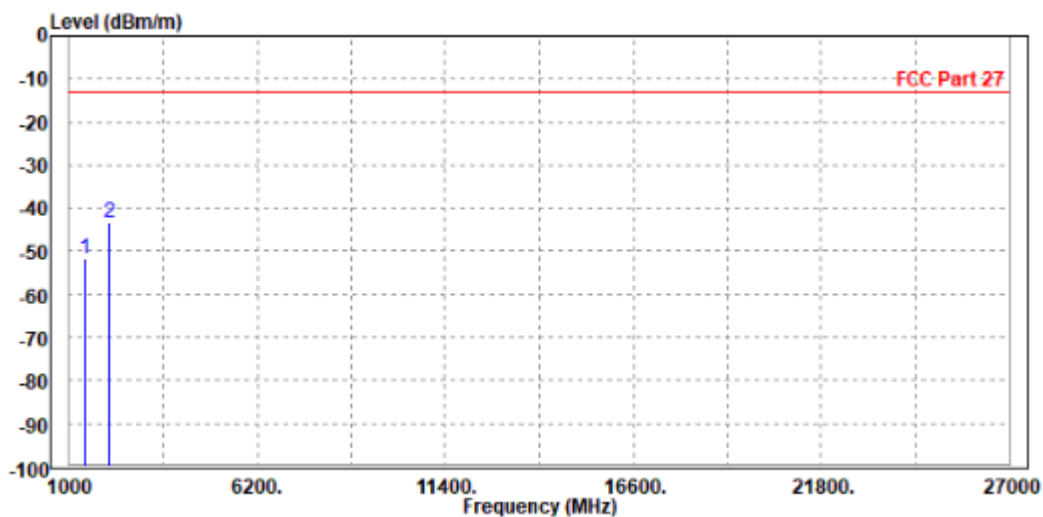



**BUREAU
VERITAS**

Test Report No.: W7L-P21090006RF07

CH23095

MODE	TX channel 23095	FREQUENCY RANGE	Above 1000MHz
ENVIRONMENTAL CONDITIONS	23deg. C, 70%RH	INPUT POWER	AC 120V/60Hz
TESTED BY	Jace Hu		
ANTENNA POLARITY & TEST DISTANCE: HORIZONTAL AT 3 M			

	Freq	Level	Read Level	Limit Line	Over Limit	Factor	Remark	Pol/Phase
	MHz	dBm/m	dBm	dBm/m	dB	dB/m		
1	1416.000	-48.16	-49.24	-13.00	-35.16	1.08	Peak	Horizontal
2	PP 2122.500	-34.63	-42.30	-13.00	-21.63	7.67	Peak	Horizontal

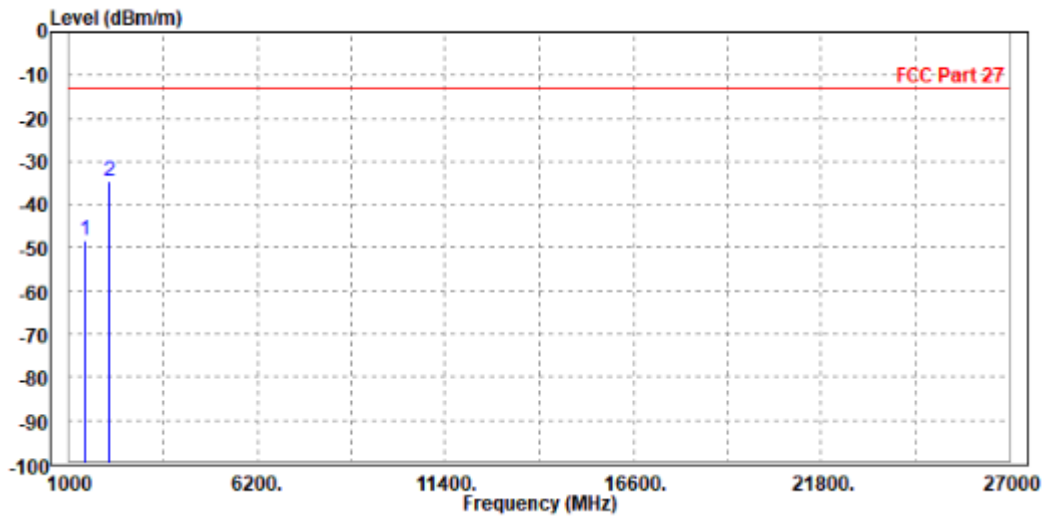



Test Report No.: W7L-P21090006RF07

MODE	TX channel 23095	FREQUENCY RANGE	Above 1000MHz
ENVIRONMENTAL CONDITIONS	23deg. C, 70%RH	INPUT POWER	AC 120V/60Hz
TESTED BY	Jace Hu		
ANTENNA POLARITY & TEST DISTANCE: VERTICAL AT 3 M			

	Freq	Level	Read Level	Limit Line	Over Limit	Factor	Remark	Pol/Phase
	MHz	dBm/m	dBm	dBm/m	dB	dB/m		
1	1416.000	-41.11	-42.80	-13.00	-28.11	1.69	Peak	Vertical
2	PP 2122.500	-40.01	-46.70	-13.00	-27.01	6.69	Peak	Vertical

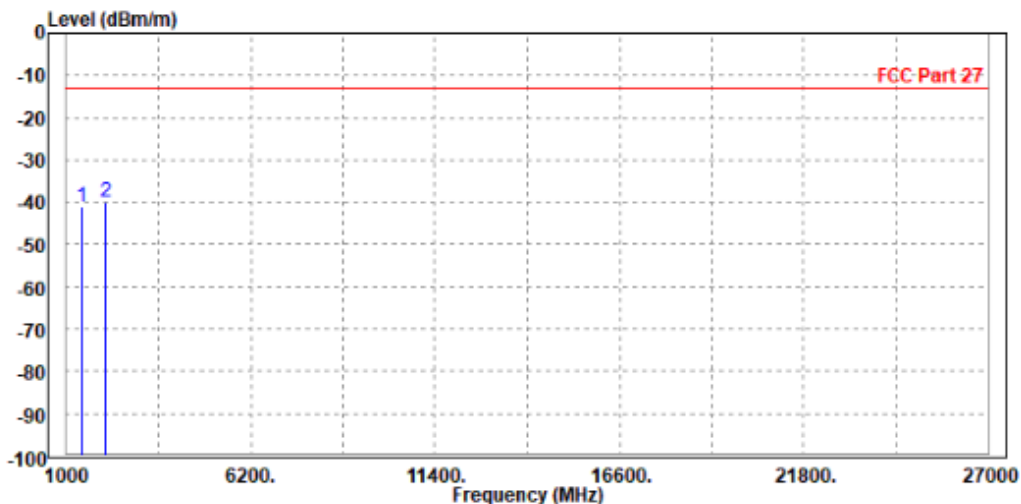



Test Report No.: W7L-P21090006RF07

CH23130

MODE	TX channel 23130	FREQUENCY RANGE	Above 1000MHz
ENVIRONMENTAL CONDITIONS	23deg. C, 70%RH	INPUT POWER	AC 120V/60Hz
TESTED BY	Jace Hu		
ANTENNA POLARITY & TEST DISTANCE: HORIZONTAL AT 3 M			

	Freq	Level	Read Level	Limit Line	Over Limit	Factor	Remark	Pol/Phase
	MHz	dBm/m	dBm	dBm/m	dB	dB/m		
1	PP 1422.000	-40.13	-41.24	-13.00	-27.13	1.11	Peak	Horizontal
2	2144.000	-47.25	-54.94	-13.00	-34.25	7.69	Peak	Horizontal

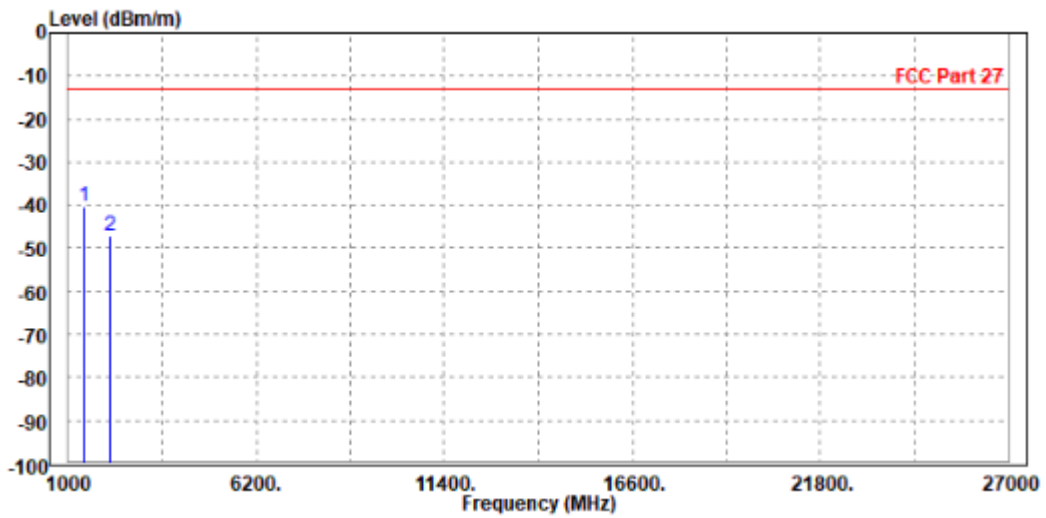



**BUREAU
VERITAS**

Test Report No.: W7L-P21090006RF07

MODE	TX channel 23130	FREQUENCY RANGE	Above 1000MHz
ENVIRONMENTAL CONDITIONS	23deg. C, 70%RH	INPUT POWER	AC 120V/60Hz
TESTED BY	Jace Hu		
ANTENNA POLARITY & TEST DISTANCE: VERTICAL AT 3 M			

	Freq	Level	Read Level	Limit Line	Over Limit	Factor	Remark	Pol/Phase
	MHz	dBm/m	dBm	dBm/m	dB	dB/m		
1	PP 1416.000	-40.03	-41.72	-13.00	-27.03	1.69	Peak	Vertical
2	2133.000	-47.50	-54.20	-13.00	-34.50	6.70	Peak	Vertical

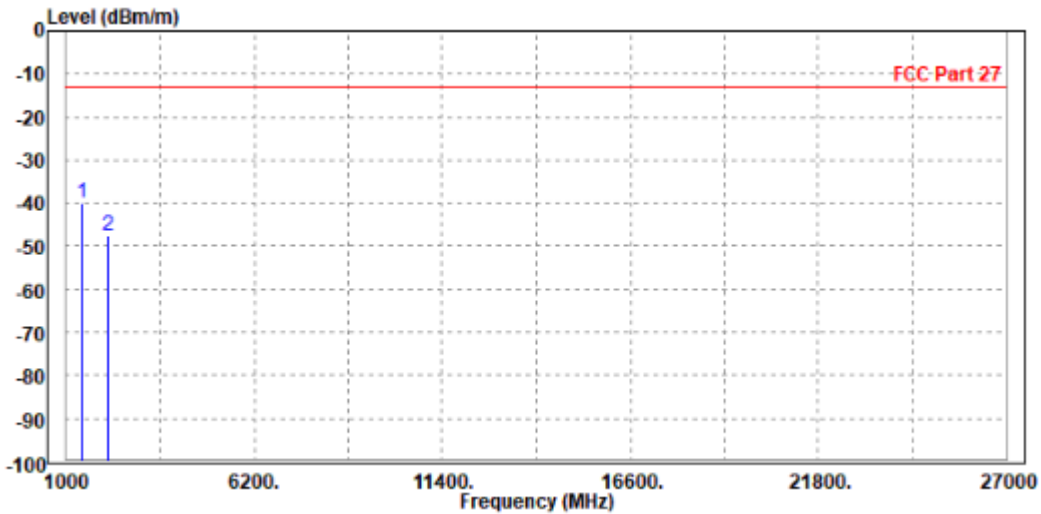

3.7 PEAK TO AVERAGE RATIO

3.7.1 LIMITS OF PEAK TO AVERAGE RATIO MEASUREMENT

In measuring transmissions in this band using an average power technique, the peak to-average ratio (PAR) of the transmission may not exceed 13 dB

3.7.2 TEST SETUP

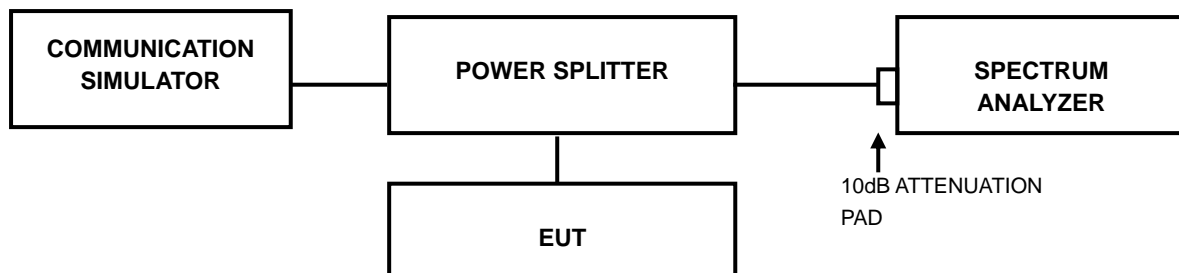

3.7.3 TEST PROCEDURES

1. Set resolution/measurement bandwidth \geq signal's occupied bandwidth;
2. Set the number of counts to a value that stabilizes the measured CCDF curve;
3. Record the maximum PAPR level associated with a probability of 0.1%.



Test Report No.: W7L-P21090006RF07

3.7.4 TEST RESULTS

NOTE: N/A refer to original report RF180521W014-3



Test Report No.: W7L-P21090006RF07

4 INFORMATION ON THE TESTING LABORATORIES

We, BV 7LAYERS COMMUNICATIONS TECHNOLOGY (SHENZHEN) CO. LTD., were founded in 2015 to provide our best service in EMC, Radio, Telecom and Safety consultation. Our laboratories are accredited and approved according to ISO/IEC 17025.

If you have any comments, please feel free to contact us at the following:

Shenzhen EMC/RF Lab:

Tel: +86-755-88696566

Fax: +86-755-88696577

Email: customerservice.dg@cn.bureauveritas.com

Web Site: www.adt.com.tw

The address and road map of all our labs can be found in our web site also.



Test Report No.: W7L-P21090006RF07

5 APPENDIX A – MODIFICATIONS RECORDERS FOR ENGINEERING CHANGES TO THE EUT BY THE LAB

No any modifications are made to the EUT by the lab during the test.

---END---