



BUREAU VERITAS

Test Report No.: RF180522W005-3



FCC TEST REPORT

(Part 15, Subpart E)

Applicant:	PAX Technology Limited
Address:	Room 2416, 24/F., Sun Hung Kai Centre, 30 Harbour Road, Wanchai, Hong Kong

Manufacturer or Supplier:	PAX Computer Technology (Shenzhen) Co., Ltd.
Address:	4/F, No.3 Building, Software Park, Second Central Science-Tech Road, High-Tech industrial Park, Shenzhen, Guangdong, P.R.C.
Product:	Integrated Smart Terminal
Brand Name:	PAX
Model Name:	E800
FCC ID:	V5PE800
Date of tests:	May 26, 2018 ~ Jul. 06, 2018

The tests have been carried out according to the requirements of the following standard:

FCC Part 15, Subpart E, Section 15.407

CONCLUSION: The submitted sample was found to COMPLY with the test requirement

Prepared by Roger Li
Engineer / Mobile Department

Approved by Sam Tung
Manager / Mobile Department

Date: Jul. 10, 2018

Date: Jul. 10, 2018

This report is governed by, and incorporates by reference, CPS Conditions of Service as posted at the date of issuance of this report at <http://www.bureauveritas.com/home/about-us/our-business/cps/about-us/terms-conditions> and is intended for your exclusive use. Any copying or replication of this report to or for any other person or entity, or use of our name or trademark, is permitted only with our prior written permission. This report sets forth our findings solely with respect to the test samples identified herein. The results set forth in this report are not indicative or representative of the quality or characteristics of the lot from which a test sample was taken or any similar or identical product unless specifically and expressly noted. Our report includes all of the tests requested by you and the results thereof based upon the information that you provided to us. Measurement uncertainty is only provided upon request for accredited tests. You have 60 days from date of issuance of this report to notify us of any material error or omission caused by our negligence or if you require measurement uncertainty; provided, however, that such notice shall be in writing and shall specifically address the issue you wish to raise. A failure to raise such issue within the prescribed time shall constitute your unqualified acceptance of the completeness of this report, the tests conducted and the correctness of the report contents.



TABLE OF CONTENTS

RELEASE CONTROL RECORD 4

1 SUMMARY OF TEST RESULTS..... 5

1.1 MEASUREMENT UNCERTAINTY 5

2 GENERAL INFORMATION 6

2.1 GENERAL DESCRIPTION OF EUT 6

2.2 DESCRIPTION OF TEST MODES 8

2.2.1 TEST MODE APPLICABILITY AND TESTED CHANNEL DETAIL..... 10

2.3 DUTY CYCLE OF TEST SIGNAL 13

2.4 DESCRIPTION OF SUPPORT UNITS 14

2.4.1 CONFIGURATION OF SYSTEM UNDER TEST 15

2.5 GENERAL DESCRIPTION OF APPLIED STANDARDS 15

3 TEST TYPES AND RESULTS..... 16

3.1 RADIATED EMISSION AND BANDEDGE MEASUREMENT 16

3.1.1 LIMITS OF RADIATED EMISSION AND BANDEDGE MEASUREMENT 16

3.1.2 LIMITS OF UNWANTED EMISSION 17

3.1.3 TEST INSTRUMENTS..... 18

3.1.4 TEST PROCEDURES 19

3.1.5 DEVIATION FROM TEST STANDARD 19

3.1.6 TEST SETUP 20

3.1.7 EUT OPERATING CONDITION 21

3.1.8 TEST RESULTS 22

3.2 CONDUCTED EMISSION MEASUREMENT 70

3.2.1 LIMITS OF CONDUCTED EMISSION MEASUREMENT 70

3.2.2 TEST INSTRUMENTS..... 70

3.2.3 TEST PROCEDURES 70

3.2.4 DEVIATION FROM TEST STANDARD 71

3.2.5 TEST SETUP 71

3.2.6 EUT OPERATING CONDITIONS 71

3.2.7 TEST RESULTS 72

3.3 MAXIMUM CONDUCTED OUTPUT POWER MEASUREMENT 74

3.3.1 LIMITS OF MAXIMUM CONDUCTED OUTPUT POWER MEASUREMENT 74

3.3.2 TEST SETUP 75



3.3.3	TEST INSTRUMENTS.....	75
3.3.4	TEST PROCEDURE.....	76
3.3.5	DEVIATION FROM TEST STANDARD	78
3.3.6	EUT OPERATING CONDITIONS	78
3.3.7	TEST RESULTS	79
3.4	MAXIMUM POWER SPECTRAL DENSITY MEASUREMENT.....	92
3.4.1	LIMITS OF MAXIMUM POWER SPECTRAL DENSITY MEASUREMENT	92
3.4.2	TEST SETUP	92
3.4.3	TEST INSTRUMENTS.....	92
3.4.4	TEST PROCEDURES	93
3.4.5	DEVIATION FROM TEST STANDARD	93
3.4.6	EUT OPERATING CONDITIONS	93
3.4.7	TEST RESULTS	94
3.5	FREQUENCY STABILITY	101
3.5.1	LIMITS OF FREQUENCY STABILITY MEASUREMENT.....	101
3.5.2	TEST SETUP.....	101
3.5.3	TEST INSTRUMENTS.....	101
3.5.4	TEST PROCEDURE.....	102
3.5.5	DEVIATION FROM TEST STANDARD	102
3.5.6	EUT OPERATING CONDITION	102
3.5.7	TEST RESULTS	103
4	PHOTOGRAPHS OF THE TEST CONFIGURATION	105
5	APPENDIX A – MODIFICATIONS RECORDERS FOR ENGINEERING CHANGES TO THE EUT BY THE LAB	106



**BUREAU
VERITAS**

Test Report No.: RF180522W005-3

RELEASE CONTROL RECORD

ISSUE NO.	REASON FOR CHANGE	DATE ISSUED
RF180522W005-3	Original release	Jul. 10, 2018



1 SUMMARY OF TEST RESULTS

The EUT has been tested according to the following specifications:

APPLIED STANDARD: FCC PART 15, SUBPART E (SECTION 15.407)			
STANDARD SECTION	TEST TYPE AND LIMIT	RESULT	REMARK
15.407(b)(5)	AC Power Conducted Emission	PASS	Meet the requirement of limit. Minimum passing margin is -14.66dB at 3.784000MHz.
15.407(b) (1/2/3/4/6)	Radiated Emission & Band Edge Measurement	PASS	Meet the requirement of limit. Minimum passing margin is -2.98dB at 5470MHz.
15.407(a/1/2/3)	Maximum conducted output Power	PASS	Meet the requirement of limit.
15.407(a/1/2/3)	Peak Power Spectral Density	PASS	Meet the requirement of limit.
15.407(e)	6 dB Bandwidth	PASS	Meet the requirement of limit. (U-NII-3 Band only)
15.407(g)	Frequency Stability	PASS	Meet the requirement of limit.
15.203	Antenna Requirement	PASS	No antenna connector is used.

1.1 MEASUREMENT UNCERTAINTY

Where relevant, the following measurement uncertainty levels have been estimated for tests performed on the EUT as specified in CISPR 16-4-2:

MEASUREMENT	FREQUENCY	UNCERTAINTY
Conducted emissions	9kHz~30MHz	2.66dB
Radiated emissions	9KHz ~ 30MHz	2.68dB
	30MHz ~ 1GMHz	3.26dB
	1GHz ~ 18GHz	4.48dB
	18GHz ~ 40GHz	4.12dB

This uncertainty represents an expanded uncertainty expressed at approximately the 95% confidence level using a coverage factor of k = 2.



2 GENERAL INFORMATION

2.1 GENERAL DESCRIPTION OF EUT

EUT	Integrated Smart Terminal
MODEL NO.	E800
POWER SUPPLY	24Vdc (adapter or host equipment) 7.2Vdc (Li-ion, battery)
MODULATION TYPE	64QAM, 16QAM, QPSK, BPSK
MODULATION TECHNOLOGY	OFDM
TRANSFER RATE	802.11a: 54.0/ 48.0/ 36.0/ 24.0/ 18.0/ 12.0/ 9.0/ 6.0Mbps 802.11n: up to MCS7 802.11ac: up to 390.0Mbps
OPERATING FREQUENCY	5180 ~ 5240MHz, 5260 ~ 5320MHz, 5500 ~ 5700MHz, 5745 ~ 5825MHz
NUMBER OF CHANNEL	5180 ~ 5240MHz: 4 for 802.11a, 802.11n (20MHz) 2 for 802.11n (40MHz) 1 for 802.11ac (80MHz) 5260 ~ 5320MHz: 4 for 802.11a, 802.11n (20MHz) 2 for 802.11n (40MHz) 1 for 802.11ac (80MHz) 5500 ~ 5700MHz: 11 for 802.11a, 802.11n (20MHz) 5 for 802.11n (40MHz) 2 for 802.11ac (80MHz) 5745 ~ 5825MHz: 5 for 802.11a, 802.11n (20MHz) 2 for 802.11n (40MHz) 1 for 802.11ac (80MHz)
AVERAGE POWER	7.69mW for 5180 ~ 5240MHz 6.09mW for 5260 ~ 5320MHz 9.75mW for 5500 ~ 5700MHz 8.85mW for 5745 ~ 5825MHz
ANTENNA TYPE	PIFA Antenna with 2dBi gain
HW VERSION	E800-XXXXX-XXXX-XXX-XX
SW VERSION	V0.0.0.1
I/O PORTS	Refer to user's manual
CABLE SUPPLIED	N/A

NOTE:

- For a more detailed features description, please refer to the manufacturer's specifications or the user's manual.



2. The EUT was powered by the following adapter:

ADAPTER	
BRAND:	HOIOTO
MODEL:	ADS-65HI-19A-3 24065E
INPUT:	AC 100-240V, 1500mA
OUTPUT:	DC 24V, 2700mA

3. The EUT incorporates a SISO function. Physically, the EUT provides one completed transmitter and one receiver.

MODULATION MODE	TX FUNCTION
802.11a	1TX/1RX
802.11n (20MHz)	1TX/1RX
802.11n (40MHz)	1TX/1RX
802.11ac (80MHz)	1TX/1RX

4. For the test results, the EUT had been tested with all conditions. But only the worst case was shown in test report.



2.2 DESCRIPTION OF TEST MODES

FOR 5150 ~ 5250MHz

4 channels are provided for 802.11a, 802.11n (20MHz):

CHANNEL	FREQUENCY	CHANNEL	FREQUENCY
36	5180 MHz	44	5220 MHz
40	5200 MHz	48	5240 MHz

2 channels are provided for 802.11n (40MHz):

CHANNEL	FREQUENCY	CHANNEL	FREQUENCY
38	5190 MHz	46	5230 MHz

1 channel is provided for 802.11ac (80MHz):

CHANNEL	FREQUENCY	CHANNEL	FREQUENCY
42	5210 MHz		

FOR 5250 ~ 5350MHz

4 channels are provided for 802.11a, 802.11n (20MHz):

CHANNEL	FREQUENCY	CHANNEL	FREQUENCY
52	5260 MHz	60	5300 MHz
56	5280 MHz	64	5320 MHz

2 channels are provided for 802.11n (40MHz):

CHANNEL	FREQUENCY	CHANNEL	FREQUENCY
54	5270 MHz	62	5310 MHz

1 channel is provided for 802.11ac (80MHz):

CHANNEL	FREQUENCY	CHANNEL	FREQUENCY
58	5290 MHz		



FOR 5470 ~ 5725MHz

11 channels are provided for 802.11a, 802.11n (20MHz):

CHANNEL	FREQUENCY	CHANNEL	FREQUENCY
100	5500 MHz	124	5620 MHz
104	5520 MHz	128	5640 MHz
108	5540 MHz	132	5660 MHz
112	5560 MHz	136	5680 MHz
116	5580 MHz	140	5700 MHz
120	5660 MHz		

5 channels are provided for 802.11n (40MHz):

CHANNEL	FREQUENCY	CHANNEL	FREQUENCY
102	5510 MHz	126	5630 MHz
110	5550 MHz	134	5670 MHz
118	5590 MHz		

2 channel is provided for 802.11ac (80MHz):

CHANNEL	FREQUENCY	CHANNEL	FREQUENCY
106	5530 MHz	122	5610 MHz

FOR 5725 ~ 5850MHz

5 channels are provided for 802.11a, 802.11n (20MHz):

CHANNEL	FREQUENCY	CHANNEL	FREQUENCY
149	5745 MHz	161	5805 MHz
153	5765 MHz	165	5825 MHz
157	5785 MHz		

2 channels are provided for 802.11n (40MHz):

CHANNEL	FREQUENCY	CHANNEL	FREQUENCY
151	5755 MHz	159	5795 MHz

1 channel is provided for 802.11ac (80MHz):

CHANNEL	FREQUENCY	CHANNEL	FREQUENCY
155	5775 MHz		



2.2.1 TEST MODE APPLICABILITY AND TESTED CHANNEL DETAIL

EUT CONFIGURE MODE	APPLICABLE TO				DESCRIPTION
	RE≥1G	RE<1G	PLC	APCM	
A	√	√	√	-	Powered by Adapter with wifi(5G) link
B	-	-	-	√	Powered by Battery with wifi(5G) link
C	-	-	-	-	Powered by USB with wifi(5G) link

Where **RE≥1G**: Radiated Emission above 1GHz **RE<1G**: Radiated Emission below 1GHz
PLC: Power Line Conducted Emission **APCM**: Antenna Port Conducted Measurement

NOTE:
The EUT had been pre-tested on the positioned of each 3 axis. The worst case was found when positioned on **X-plane**.
NOTE: "-" means no effect.

RADIATED EMISSION TEST (ABOVE 1GHz):

- Pre-Scan has been conducted to determine the worst-case mode from all possible combinations between available modulations, data rates and antenna ports (if EUT with antenna diversity architecture).
- Following channel(s) was (were) selected for the final test as listed below.

EUT CONFIGURE MODE	MODE	FREQ. BAND (MHz)	AVAILABLE CHANNEL	TESTED CHANNEL	MODULATION TECHNOLOGY	MODULATION TYPE	DATA RATE (Mbps)
A	802.11a	5180-5240	36 to 48	36, 40, 48	OFDM	BPSK	6.0
A	802.11n (20MHz)		36 to 48	36, 40, 48	OFDM	BPSK	MCS0
A	802.11n (40MHz)		38 to 46	38, 46	OFDM	BPSK	MCS0
A	802.11ac (80MHz)		42	42	OFDM	BPSK	V0
A	802.11a	5260-5320	52 to 64	52, 60, 64	OFDM	BPSK	6.0
A	802.11n (20MHz)		52 to 64	52, 60, 64	OFDM	BPSK	MCS0
A	802.11n (40MHz)		54 to 62	54, 62	OFDM	BPSK	MCS0
A	802.11ac (80MHz)		58	58	OFDM	BPSK	V0
A	802.11a	5500-5700	100 to 140	100, 116, 140	OFDM	BPSK	6.0
A	802.11n (20MHz)		100 to 140	100, 116, 140	OFDM	BPSK	MCS0
A	802.11n (40MHz)		102 to 134	102, 110, 134	OFDM	BPSK	MCS0
A	802.11ac (80MHz)		106	106	OFDM	BPSK	V0
A	802.11a	5745-5825	149 to 165	149, 157, 165	OFDM	BPSK	6.0
A	802.11n (20MHz)		149 to 165	149, 157, 165	OFDM	BPSK	MCS0
A	802.11n (40MHz)		151 to 159	151, 159	OFDM	BPSK	MCS0
A	802.11ac (80MHz)		155	155	OFDM	BPSK	V0



RADIATED EMISSION TEST (BELOW 1GHz):

- Pre-Scan has been conducted to determine the worst-case mode from all possible combinations between available modulations, data rates and antenna ports (if EUT with antenna diversity architecture).
- Following channel(s) was (were) selected for the final test as listed below.

EUT CONFIGURE MODE	MODE	FREQ. BAND (MHz)	AVAILABLE CHANNEL	TESTED CHANNEL	MODULATION TECHNOLOGY	MODULATION TYPE	DATA RATE (Mbps)
A	802.11n (20MHz)	5500-5700	100 to 140	100	OFDM	BPSK	MCS0

POWER LINE CONDUCTED EMISSION TEST:

- Pre-Scan has been conducted to determine the worst-case mode from all possible combinations between available modulations, data rates and antenna ports (if EUT with antenna diversity architecture).
- Following channel(s) was (were) selected for the final test as listed below.

EUT CONFIGURE MODE	MODE	FREQ. BAND (MHz)	AVAILABLE CHANNEL	TESTED CHANNEL	MODULATION TECHNOLOGY	MODULATION TYPE	DATA RATE (Mbps)
A	802.11n (20MHz)	5500-5700	100 to 140	100	OFDM	BPSK	MCS0

BANDEDGE MEASUREMENT:

- Pre-Scan has been conducted to determine the worst-case mode from all possible combinations between available modulations, data rates and antenna ports (if EUT with antenna diversity architecture).
- Following channel(s) was (were) selected for the final test as listed below.

EUT CONFIGURE MODE	MODE	FREQ. BAND (MHz)	AVAILABLE CHANNEL	TESTED CHANNEL	MODULATION TECHNOLOGY	MODULATION TYPE	DATA RATE (Mbps)
A	802.11a	5180-5240	36 to 48	36, 48	OFDM	BPSK	6.0
A	802.11n (20MHz)		36 to 48	36, 48	OFDM	BPSK	MCS0
A	802.11n (40MHz)		38 to 46	38, 46	OFDM	BPSK	MCS0
A	802.11ac (80MHz)		42	42	OFDM	BPSK	V0
A	802.11a	5260-5320	52 to 64	52, 64	OFDM	BPSK	6.0
A	802.11n (20MHz)		52 to 64	52, 64	OFDM	BPSK	MCS0
A	802.11n (40MHz)		54 to 62	54, 62	OFDM	BPSK	MCS0
A	802.11ac (80MHz)		58	58	OFDM	BPSK	V0
A	802.11a	5500-5700	100 to 140	100, 140	OFDM	BPSK	6.0
A	802.11n (20MHz)		100 to 140	100, 140	OFDM	BPSK	MCS0
A	802.11n (40MHz)		102 to 134	102, 134	OFDM	BPSK	MCS0
A	802.11ac (80MHz)		106	106	OFDM	BPSK	V0
A	802.11a	5745-5825	149 to 165	149, 165	OFDM	BPSK	6.0
A	802.11n (20MHz)		149 to 165	149, 165	OFDM	BPSK	MCS0
A	802.11n (40MHz)		151 to 159	151, 159	OFDM	BPSK	MCS0
A	802.11ac (80MHz)		155	155	OFDM	BPSK	V0



ANTENNA PORT CONDUCTED MEASUREMENT:

- This item includes all test value of each mode, but only includes spectrum plot of worst value of each mode.
- Pre-Scan has been conducted to determine the worst-case mode from all possible combinations between available modulations, data rates and antenna ports (if EUT with antenna diversity architecture).
- Following channel(s) was (were) selected for the final test as listed below.

EUT CONFIGURE MODE	MODE	FREQ. BAND (MHz)	AVAILABLE CHANNEL	TESTED CHANNEL	MODULATION TECHNOLOGY	MODULATION TYPE	DATA RATE (Mbps)
B	802.11a	5180-5240	36 to 48	36, 40, 48	OFDM	BPSK	6.0
B	802.11n (20MHz)		36 to 48	36, 40, 48	OFDM	BPSK	MCS0
B	802.11n (40MHz)		38 to 46	38, 46	OFDM	BPSK	MCS0
B	802.11ac (80MHz)		42	42	OFDM	BPSK	V0
B	802.11a	5260-5320	52 to 64	52, 60, 64	OFDM	BPSK	6.0
B	802.11n (20MHz)		52 to 64	52, 60, 64	OFDM	BPSK	MCS0
B	802.11n (40MHz)		54 to 62	54, 62	OFDM	BPSK	MCS0
B	802.11ac (80MHz)		58	58	OFDM	BPSK	V0
B	802.11a	5500-5700	100 to 140	100, 116, 140	OFDM	BPSK	6.0
B	802.11n (20MHz)		100 to 140	100, 116, 140	OFDM	BPSK	MCS0
B	802.11n (40MHz)		102 to 134	102, 110, 134	OFDM	BPSK	MCS0
B	802.11ac (80MHz)		106	106	OFDM	BPSK	V0
B	802.11a	5745-5825	149 to 165	149, 165	OFDM	BPSK	6.0
B	802.11n (20MHz)		149 to 165	149, 165	OFDM	BPSK	MCS0
B	802.11n (40MHz)		151 to 159	151, 159	OFDM	BPSK	MCS0
B	802.11ac (80MHz)		155	155	OFDM	BPSK	V0

TEST CONDITION:

APPLICABLE TO	ENVIRONMENTAL CONDITIONS	INPUT POWER	TESTED BY
RE<1G	23deg. C, 62%RH	DC 24V from adaptor	Vincent Chen
RE≥1G	23deg. C, 62%RH	DC 24V from adaptor	Vincent Chen
PLC	24deg. C, 61%RH	DC 24V from adaptor	John Wen
APCM	23.5deg. C, 60%RH	DC 7.2V By battery	Wenliang Wu



2.3 DUTY CYCLE OF TEST SIGNAL

Duty cycle of test signal is < 98%, duty factor shall be considered.

802.11a: Duty cycle = 1.392/1.440 = 0.967, Duty factor = 10 * log(1/0.967) = 0.147

802.11n (20MHz): Duty cycle = 1.306/1.361 = 0.955, Duty factor = 10 * log(1/0.955) = 0.199

802.11n (40MHz): Duty cycle = 0.646/0.698 = 0.926, Duty factor = 10 * log(1/0.926) = 0.336

802.11ac (80MHz): Duty cycle = 0.323/0.369 = 0.875, Duty factor = 10 * log(1/0.875) = 0.578

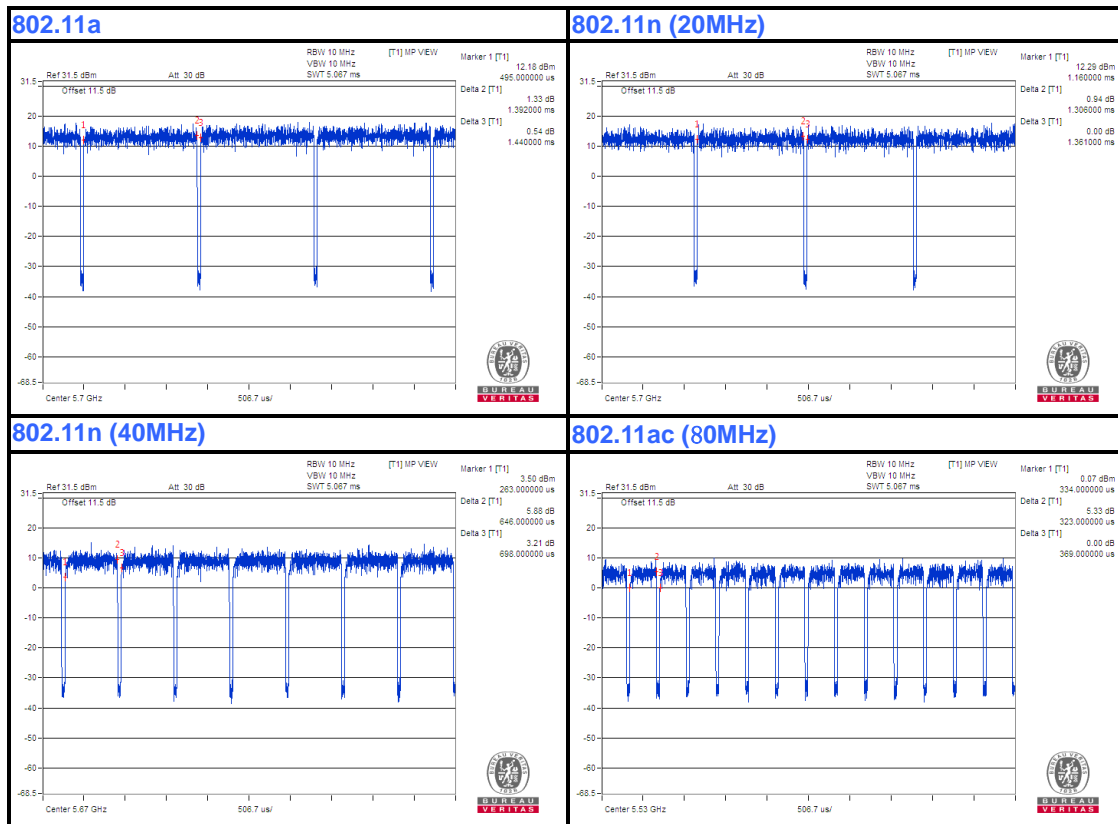



2.4 DESCRIPTION OF SUPPORT UNITS

The EUT has been tested as an independent unit together with other necessary accessories or support units. The following support units or accessories were used to form a representative test configuration during the tests.

NO.	PRODUCT	BRAND	MODEL NO.	SERIAL NO.	FCC ID
1	PC	HP	A6608CN	3CR83825X3	N/A

NO.	SIGNAL CABLE DESCRIPTION OF THE ABOVE SUPPORT UNITS
1	AC Line: Unshielded, Detachable 1.5m

NOTE:

1. All power cords of the above support units are non shielded (1.8m).



2.4.1 CONFIGURATION OF SYSTEM UNDER TEST

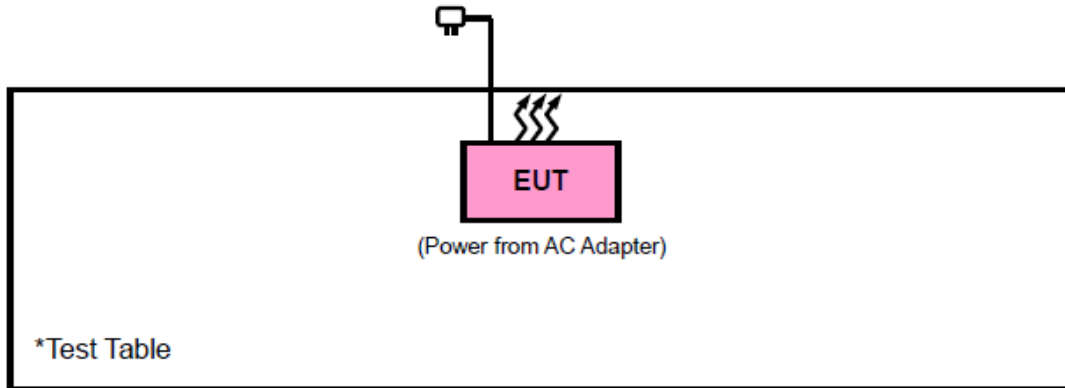

2.5 GENERAL DESCRIPTION OF APPLIED STANDARDS

The EUT is a RF Product. According to the specifications of the manufacturer, it must comply with the requirements of the following standards:

FCC Part 15, Subpart E (15.407)

KDB 789033 D02 General U-NII Test Procedures New Rules v02r01

ANSI C63.10-2013

All test items have been performed and recorded as per the above standards.

NOTE: The EUT is also considered as a kind of computer peripheral, because the connection to computer is necessary for typical use. It has been verified to comply with the requirements of FCC Part 15, Subpart B, Class B (Certification). The test report has been issued separately.



3 TEST TYPES AND RESULTS

3.1 RADIATED EMISSION AND BANDEDGE MEASUREMENT

3.1.1 LIMITS OF RADIATED EMISSION AND BANDEDGE MEASUREMENT

Radiated emissions which fall in the restricted bands must comply with the radiated emission limits specified as below table:

FREQUENCIES (MHz)	FIELD STRENGTH (microvolts/meter)	MEASUREMENT DISTANCE (meters)
0.009 ~ 0.490	2400/F(kHz)	300
0.490 ~ 1.705	24000/F(kHz)	30
1.705 ~ 30.0	30	30
30 ~ 88	100	3
88 ~ 216	150	3
216 ~ 960	200	3
Above 960	500	3

NOTE:

1. The lower limit shall apply at the transition frequencies.
2. Emission level (dBuV/m) = 20 log Emission level (uV/m).
3. For frequencies above 1000MHz, the field strength limits are based on average detector, however, the peak field strength of any emission shall not exceed the maximum permitted average limits, specified above by more than 20dB under any condition of modulation.



3.1.2 LIMITS OF UNWANTED EMISSION

RESTRICTED BANDS	APPLICABLE TO	LIMIT	
	789033 D02 General UNII Test Procedures New Rules v01r04	FIELD STRENGTH AT 3m (dBµV/m)	
PK : 74		AV : 54	
OUT OF THE RESTRICTED BANDS	APPLICABLE TO	EIRP LIMIT (dBm/MHz)	EQUIVALENT FIELD STRENGTH AT 3m (dBµV/m)
	15.407(b)(1)	PK : -27	PK : 68.3
	15.407(b)(2)		
	15.407(b)(3)		
15.407(b)(4)	See note 2 (FCC 16-24)		

NOTE: The following formula is used to convert the equipment isotropic radiated power (eirp) to field strength:

$$E = \frac{1000000\sqrt{30P}}{3} \mu\text{V/m, where P is the eirp (Watts).}$$

2. All emissions shall be limited to a level of -27 dBm/MHz at 75 MHz or more above or below the band edge increasing linearly to 10 dBm/MHz at 25 MHz above or below the band edge, and from 25 MHz above or below the band edge increasing linearly to a level of 15.6 dBm/MHz at 5 MHz above or below the band edge, and from 5 MHz above or below the band edge increasing linearly to a level of 27 dBm/MHz at the band edge.



3.1.3 TEST INSTRUMENTS

Equipment	Manufacturer	Model No.	Serial No.	Last Cal.	Next Cal.
3m Semi-anechoic Chamber	ETS-LINDGREN	9m*6m*6m	Euroshieldpn-CT0001143-1216	Apr. 21,18	Apr. 20,19
Bilog Antenna	ETS-LINDGREN	3143B	00161965	Nov. 26,16	Nov. 25,18
Horn Antenna	ETS-LINDGREN	3117	00168728	Nov. 26,16	Nov. 25,18
Loop antenna	Daze	ZN30900A	0708	Nov. 20,17	Nov. 19,18
Horn Antenna (18GHz-40GHz)	N/A	QWH-SL-18-40-K-SG/QMS-00361	15433	Dec. 16,16	Dec. 15,18
Test Software	E3	V 9.160323	N/A	N/A	N/A
Test Software	ADT	ADT_Radiated V7.6.15.9.2	N/A	N/A	N/A
10dB Attenuator	JFW/USA	50HF-010-SM A	1505	Jul. 24,17	Jul. 23,18
MXE EMI Receiver	KEYSIGHT	N9038A-544	MY54450026	Mar. 16,18	Mar. 15,19
Signal Pre-Amplifier	EMSI	EMC 9135	980249	Jul. 24,17	Jul. 23,18
Signal Pre-Amplifier	EMSI	EMC 012645B	980257	Jul. 24,17	Jul. 23,18
Signal Pre-Amplifier	EMSI	EMC 184045B	980259	Jul. 24,17	Jul. 23,18

NOTE:

1. The calibration interval of the above test instruments is 12 months and the calibrations are traceable to CEPREI/CHINA, GRGT/CHINA and NIM/CHINA.
2. The test was performed in 3m Chamber.
3. The FCC Site Registration No. is 525120.



3.1.4 TEST PROCEDURES

- a. The EUT was placed on the top of a rotating table 0.8 meters (for below 1GHz) / 1.5 meters (for above 1GHz) above the ground at 3 meter chamber room for test. The table was rotated 360 degrees to determine the position of the highest radiation.
- b. The EUT was set 3 meters away from the interference-receiving antenna, which was mounted on the top of a variable-height antenna tower.
- c. The antenna is a broadband antenna, and its height is varied from one meter to four meters above the ground to determine the maximum value of the field strength. Both horizontal and vertical polarizations of the antenna are set to make the measurement.
- d. For each suspected emission, the EUT was arranged to its worst case and then the antenna was tuned to heights from 1 meter to 4 meters and the rotatable table was turned from 0 degrees to 360 degrees to find the maximum reading.
- e. The test-receiver system was set to Peak Detect Function and Specified Bandwidth with Maximum Hold Mode.
- f. If the emission level of the EUT in peak mode was 10dB lower than the limit specified, then testing could be stopped and the peak values of the EUT would be reported. Otherwise the emissions that did not have 10dB margin would be re-tested one by one using peak, quasi-peak or average method as specified and then reported in a data sheet.

NOTE:

1. The resolution bandwidth and video bandwidth of test receiver/spectrum analyzer is 120kHz for Peak detection (PK) and Quasi-peak detection (QP) at frequency below 1GHz.
2. The resolution bandwidth of test receiver/spectrum analyzer is 1MHz and video bandwidth is 3MHz for Peak detection at frequency above 1GHz.
3. The resolution bandwidth of test receiver/spectrum analyzer is 1MHz and the video bandwidth is 10Hz for Average detection (AV) at frequency above 1GHz.
4. All modes of operation were investigated and the worst-case emissions are reported.

3.1.5 DEVIATION FROM TEST STANDARD

No deviation.



3.1.6 TEST SETUP

< Frequency Range below 30MHz >

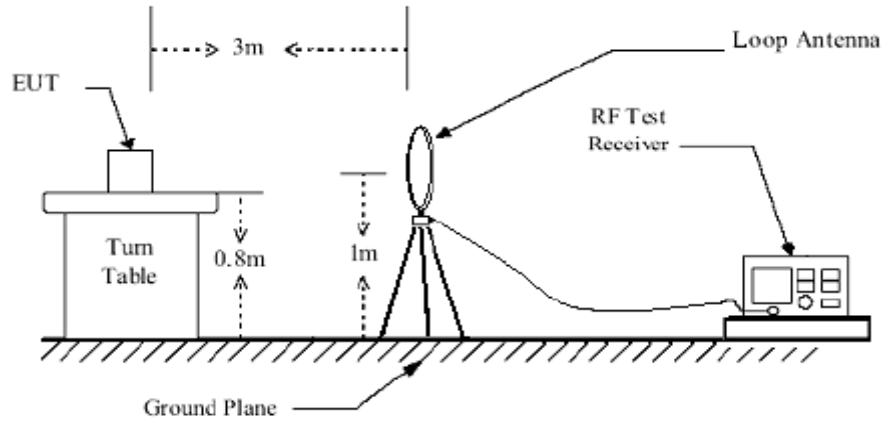

< Frequency Range 30MHz~1GHz >

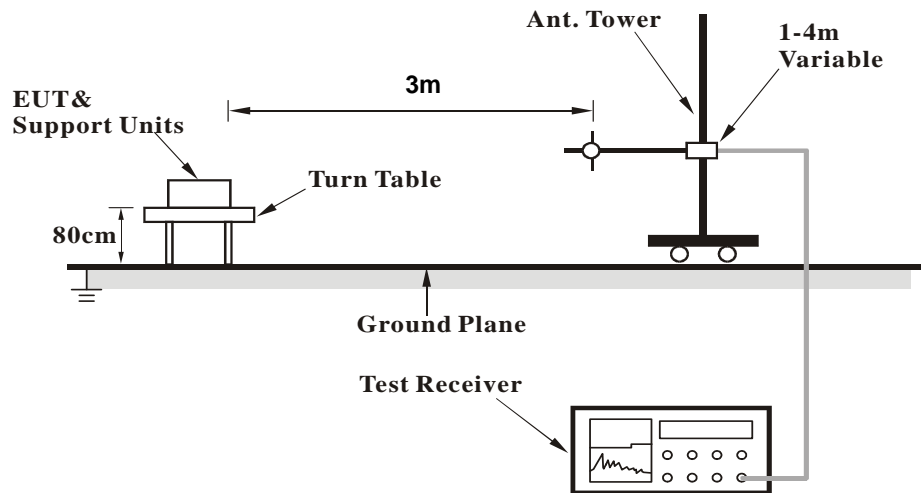



<Frequency Range above 1GHz>

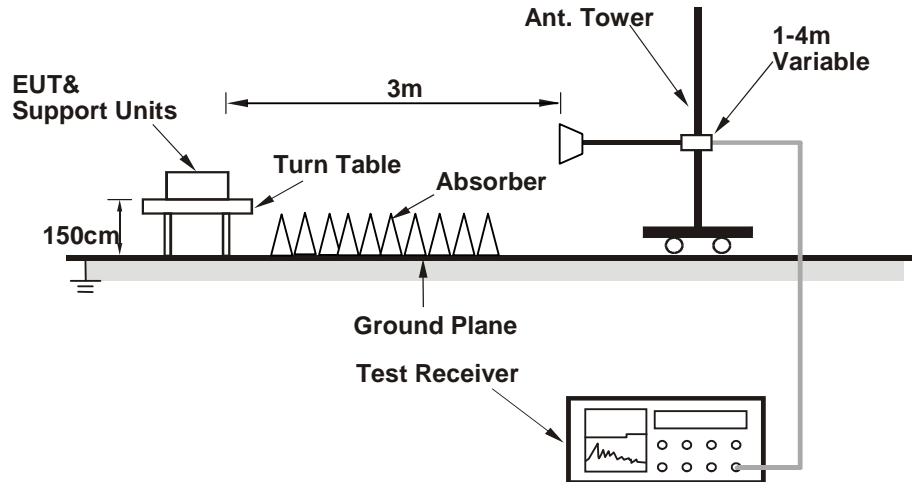

For the actual test configuration, please refer to the attached file (Test Setup Photo).

3.1.7 EUT OPERATING CONDITION

- a. Set the EUT under full load condition and placed them on a testing table.
- b. Set the transmitter part of EUT under transmission condition continuously at specific channel frequency.
- c. The necessary accessories enable the EUT in full functions.



3.1.8 TEST RESULTS

BELOW 1GHz WORST-CASE DATA:

9 KHz – 30 MHz data: the amplitude of spurious emissions attenuated more than 20 dB below the permissible value is not required in the report.

30 MHz – 1GHz data:

802.11n (20MHz)

CHANNEL	TX Channel 100	DETECTOR FUNCTION	Quasi-Peak (QP)
FREQUENCY RANGE	30MHz ~ 1GHz		

ANTENNA POLARITY & TEST DISTANCE: HORIZONTAL AT 3 M										
FREQ. (MHz)	EMISSION LEVEL (dBuV/m)	READ LEVEL (dBuV)	LIMIT (dBuV/m)	MARGIN (dB)	ANTENNA FACTOR (dB /m)	CABLE LOSS (dB)	PREAMP FACTOR (dB)	ANTENNA HEIGHT (cm)	TABLE ANGLE (Degree)	REMARK
58.13	27.06	56.81	40	-12.94	6.42	1.16	37.33	100	248	QP
144.46	31.48	57.91	43.5	-12.02	8.54	1.85	36.82	100	15	QP
235.64	29.19	51.61	46	-16.81	11.74	2.37	36.53	100	31	QP
344.28	24.31	43.14	46	-21.69	14.86	2.91	36.6	100	222	QP
485.9	24.77	40.05	46	-21.23	18.23	3.42	36.93	100	289	QP
666.32	20.69	31.66	46	-25.31	22.16	4.19	37.32	100	321	QP

REMARKS:

1. Emission level (dBuV/m) = Raw Value (dBuV) + Correction Factor (dB/m).
2. Correction Factor (dB/m) = Antenna Factor (dB/m) + Cable Factor (dB).
3. The other emission levels were very low against the limit.
4. Margin value = Emission level – Limit value.

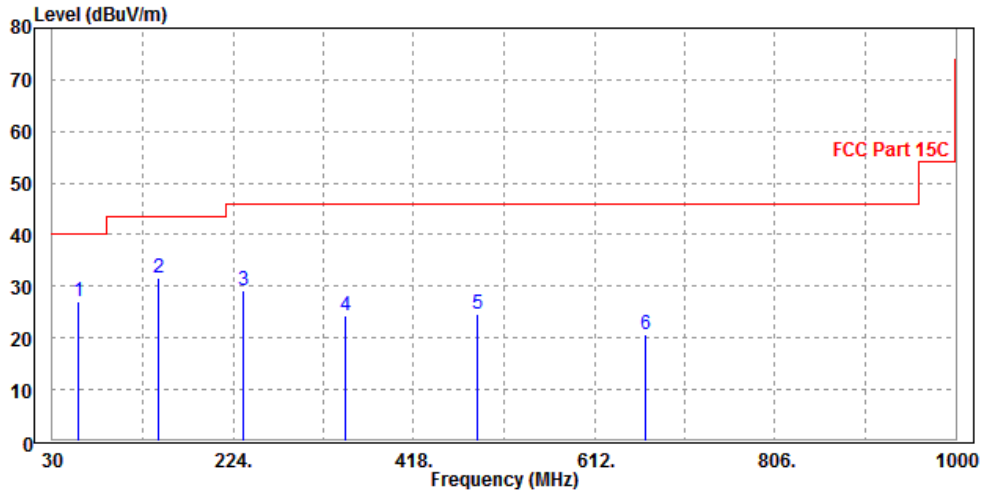



CHANNEL	Channel 100	DETECTOR FUNCTION	Quasi-Peak (QP)
FREQUENCY RANGE	30MHz ~ 1GHz		

ANTENNA POLARITY & TEST DISTANCE: VERTICAL AT 3 M										
FREQ. (MHz)	EMISSION LEVEL (dBuV/m)	READ LEVEL (dBuV)	LIMIT (dBuV/m)	MARGIN (dB)	ANTENNA FACTOR (dB /m)	CABLE LOSS (dB)	PREAMP FACTOR (dB)	ANTENNA HEIGHT (cm)	TABLE ANGLE (Degree)	REMARK
66.86	25.49	54.78	40	-14.51	6.74	1.25	37.28	100	124	QP
144.46	15.3	41.73	43.5	-28.2	8.54	1.85	36.82	100	302	QP
235.64	19.7	42.12	46	-26.3	11.74	2.37	36.53	100	196	QP
340.4	24.1	43.1	46	-21.9	14.7	2.89	36.59	100	269	QP
564.47	19.83	33.55	46	-26.17	19.62	3.81	37.15	100	33	QP
733.25	20.24	30.21	46	-25.76	23.07	4.41	37.45	100	114	QP

REMARKS:

1. Emission level (dBuV/m) = Raw Value (dBuV) + Correction Factor (dB/m).
2. Correction Factor (dB/m) = Antenna Factor (dB/m) + Cable Factor (dB).
3. The other emission levels were very low against the limit.
4. Margin value = Emission level – Limit value.

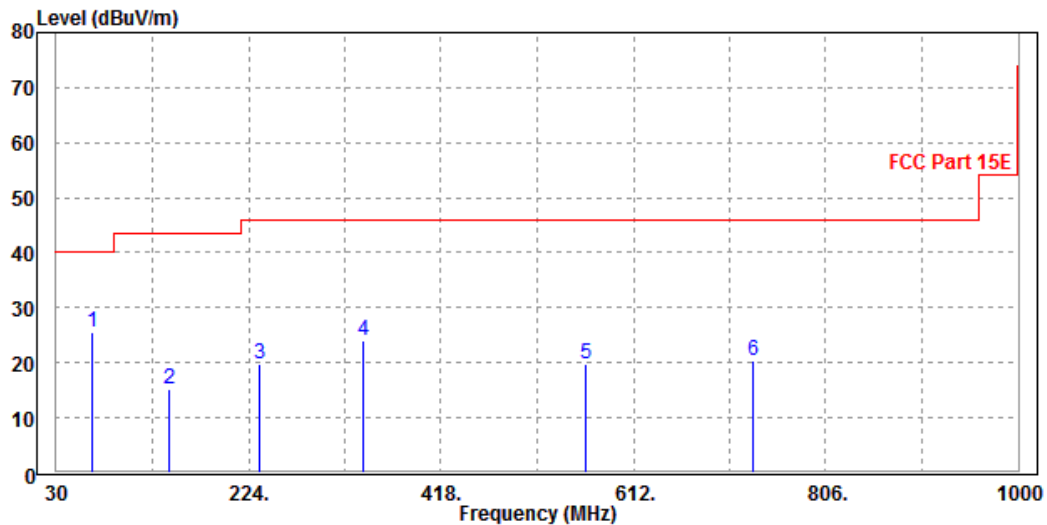



ABOVE 1GHz WORST-CASE DATA:

Note: For higher frequency, the emission is too low to be detected.

Band 1
802.11a

CHANNEL	TX Channel 36	DETECTOR FUNCTION	Peak (PK)
FREQUENCY RANGE	1GHz ~ 40GHz		Average (AV)

ANTENNA POLARITY & TEST DISTANCE: HORIZONTAL AT 3 M										
FREQ. (MHz)	EMISSION LEVEL (dBuV/m)	READ LEVEL (dBuV)	LIMIT (dBuV/m)	MARGIN (dB)	ANTENNA FACTOR (dB /m)	CABLE LOSS (dB)	PREAMP FACTOR (dB)	ANTENNA HEIGHT (cm)	TABLE ANGLE (Degree)	REMARK
5150	45.13	49.44	54	-8.87	34.48	7.42	46.21	130	100	Average
5150	56.4	60.71	74	-17.6	34.48	7.42	46.21	130	100	Peak
5180	83.61	87.88			34.52	7.43	46.22	130	100	Average
5180	93.67	97.94			34.52	7.43	46.22	130	100	Peak
5350	43.75	47.81	54	-10.25	34.72	7.47	46.25	130	100	Average
5350	53.08	57.14	74	-20.92	34.72	7.47	46.25	130	100	Peak

ANTENNA POLARITY & TEST DISTANCE: VERTICAL AT 3 M										
FREQ. (MHz)	EMISSION LEVEL (dBuV/m)	READ LEVEL (dBuV)	LIMIT (dBuV/m)	MARGIN (dB)	ANTENNA FACTOR (dB /m)	CABLE LOSS (dB)	PREAMP FACTOR (dB)	ANTENNA HEIGHT (cm)	TABLE ANGLE (Degree)	REMARK
5150	46.39	47.92	54	-7.61	37.26	7.42	46.21	100	170	Average
5150	60.15	61.68	74	-13.85	37.26	7.42	46.21	100	170	Peak
5180	81.28	82.8			37.27	7.43	46.22	100	170	Average
5180	91.8	93.32			37.27	7.43	46.22	100	170	Peak
5350	45.33	46.77	54	-8.67	37.34	7.47	46.25	100	170	Average
5350	57.28	58.72	74	-16.72	37.34	7.47	46.25	100	170	Peak

REMARKS:

- Emission Level = Read Level+ Antenna Factor + Cable Loss- Preamp Factor
Margin value = Emission level – Limit value.
- 5180MHz: Fundamental frequency.



CHANNEL	TX Channel 40	DETECTOR FUNCTION	Peak (PK)
FREQUENCY RANGE	1GHz ~ 40GHz		Average (AV)

ANTENNA POLARITY & TEST DISTANCE: HORIZONTAL AT 3 M										
FREQ. (MHz)	EMISSION LEVEL (dBuV/m)	READ LEVEL (dBuV)	LIMIT (dBuV/m)	MARGIN (dB)	ANTENNA FACTOR (dB /m)	CABLE LOSS (dB)	PREAMP FACTOR (dB)	ANTENNA HEIGHT (cm)	TABLE ANGLE (Degree)	REMARK
5150	43.24	44.77	54	-10.76	37.26	7.42	46.21	130	100	Average
5150	56.99	58.52	74	-17.01	37.26	7.42	46.21	130	100	Peak
5200	85.08	86.59			37.28	7.43	46.22	130	100	Average
5200	96.9	98.41			37.28	7.43	46.22	130	100	Peak
5350	43.61	45.05	54	-10.39	37.34	7.47	46.25	130	100	Average
5350	57.17	58.61	74	-16.83	37.34	7.47	46.25	130	100	Peak

ANTENNA POLARITY & TEST DISTANCE: VERTICAL AT 3 M										
FREQ. (MHz)	EMISSION LEVEL (dBuV/m)	READ LEVEL (dBuV)	LIMIT (dBuV/m)	MARGIN (dB)	ANTENNA FACTOR (dB /m)	CABLE LOSS (dB)	PREAMP FACTOR (dB)	ANTENNA HEIGHT (cm)	TABLE ANGLE (Degree)	REMARK
5150	46.96	48.49	54	-7.04	37.26	7.42	46.21	100	170	Average
5150	57.59	59.12	74	-16.41	37.26	7.42	46.21	100	170	Peak
5200	88.98	90.49			37.28	7.43	46.22	100	170	Average
5200	97.76	99.27			37.28	7.43	46.22	100	170	Peak
5350	47.32	48.76	54	-6.68	37.34	7.47	46.25	100	170	Average
5350	58.65	60.09	74	-15.35	37.34	7.47	46.25	100	170	Peak

REMARKS:

1. Emission Level = Read Level+ Antenna Factor + Cable Loss- Preamp Factor
Margin value = Emission level – Limit value.
2. 5200MHz: Fundamental frequency.



CHANNEL	TX Channel 48	DETECTOR FUNCTION	Peak (PK)
FREQUENCY RANGE	1GHz ~ 40GHz		Average (AV)

ANTENNA POLARITY & TEST DISTANCE: HORIZONTAL AT 3 M										
FREQ. (MHz)	EMISSION LEVEL (dBuV/m)	READ LEVEL (dBuV)	LIMIT (dBuV/m)	MARGIN (dB)	ANTENNA FACTOR (dB /m)	CABLE LOSS (dB)	PREAMP FACTOR (dB)	ANTENNA HEIGHT (cm)	TABLE ANGLE (Degree)	REMARK
5150	46.08	47.61	54	-7.92	37.26	7.42	46.21	130	100	Average
5150	58.48	60.01	74	-15.52	37.26	7.42	46.21	130	100	Peak
5240	82.12	83.61			37.3	7.44	46.23	130	100	Average
5240	93.18	94.67			37.3	7.44	46.23	130	100	Peak
5350	44.29	45.73	54	-9.71	37.34	7.47	46.25	130	100	Average
5350	60.27	61.71	74	-13.73	37.34	7.47	46.25	130	100	Peak

ANTENNA POLARITY & TEST DISTANCE: VERTICAL AT 3 M										
FREQ. (MHz)	EMISSION LEVEL (dBuV/m)	READ LEVEL (dBuV)	LIMIT (dBuV/m)	MARGIN (dB)	ANTENNA FACTOR (dB /m)	CABLE LOSS (dB)	PREAMP FACTOR (dB)	ANTENNA HEIGHT (cm)	TABLE ANGLE (Degree)	REMARK
5150	47.83	49.36	54	-6.17	37.26	7.42	46.21	100	170	Average
5150	58	59.53	74	-16	37.26	7.42	46.21	100	170	Peak
5240	83.32	84.81			37.3	7.44	46.23	100	170	Average
5240	95.54	97.03			37.3	7.44	46.23	100	170	Peak
5350	43.25	44.69	54	-10.75	37.34	7.47	46.25	100	170	Average
5350	58.54	59.98	74	-15.46	37.34	7.47	46.25	100	170	Peak

REMARKS:

1. Emission Level = Read Level+ Antenna Factor + Cable Loss- Preamp Factor
Margin value = Emission level – Limit value.
2. 5240MHz: Fundamental frequency.



802.11n (20MHz)

CHANNEL	TX Channel 36	DETECTOR FUNCTION	Peak (PK)
FREQUENCY RANGE	1GHz ~ 40GHz		Average (AV)

ANTENNA POLARITY & TEST DISTANCE: HORIZONTAL AT 3 M										
FREQ. (MHz)	EMISSION LEVEL (dBuV/m)	READ LEVEL (dBuV)	LIMIT (dBuV/m)	MARGIN (dB)	ANTENNA FACTOR (dB /m)	CABLE LOSS (dB)	PREAMP FACTOR (dB)	ANTENNA HEIGHT (cm)	TABLE ANGLE (Degree)	REMARK
5150	45.84	47.37	54	-8.16	37.26	7.42	46.21	100	155	Average
5150	55.9	57.43	74	-18.1	37.26	7.42	46.21	100	155	Peak
5180	81.32	82.84			37.27	7.43	46.22	100	155	Average
5180	94.73	96.25			37.27	7.43	46.22	100	155	Peak
5350	44.47	45.91	54	-9.53	37.34	7.47	46.25	100	155	Average
5350	55.29	56.73	74	-18.71	37.34	7.47	46.25	100	155	Peak

ANTENNA POLARITY & TEST DISTANCE: VERTICAL AT 3 M										
FREQ. (MHz)	EMISSION LEVEL (dBuV/m)	READ LEVEL (dBuV)	LIMIT (dBuV/m)	MARGIN (dB)	ANTENNA FACTOR (dB /m)	CABLE LOSS (dB)	PREAMP FACTOR (dB)	ANTENNA HEIGHT (cm)	TABLE ANGLE (Degree)	REMARK
5150	46.81	48.34	54	-7.19	37.26	7.42	46.21	100	178	Average
5150	56.8	58.33	74	-17.2	37.26	7.42	46.21	100	178	Peak
5180	88.75	90.27			37.27	7.43	46.22	100	178	Average
5180	97.91	99.43			37.27	7.43	46.22	100	178	Peak
5350	42.77	44.21	54	-11.23	37.34	7.47	46.25	100	178	Average
5350	56.49	57.93	74	-17.51	37.34	7.47	46.25	100	178	Peak

REMARKS:

1. Emission Level = Read Level+ Antenna Factor + Cable Loss- Preamp Factor
Margin value = Emission level – Limit value.
2. 5180MHz: Fundamental frequency.



CHANNEL	TX Channel 40	DETECTOR FUNCTION	Peak (PK)
FREQUENCY RANGE	1GHz ~ 40GHz		Average (AV)

ANTENNA POLARITY & TEST DISTANCE: HORIZONTAL AT 3 M										
FREQ. (MHz)	EMISSION LEVEL (dBuV/m)	READ LEVEL (dBuV)	LIMIT (dBuV/m)	MARGIN (dB)	ANTENNA FACTOR (dB /m)	CABLE LOSS (dB)	PREAMP FACTOR (dB)	ANTENNA HEIGHT (cm)	TABLE ANGLE (Degree)	REMARK
5150	45.98	47.51	54	-8.02	37.26	7.42	46.21	150	110	Average
5150	56.34	57.87	74	-17.66	37.26	7.42	46.21	150	110	Peak
5200	85.91	87.42			37.28	7.43	46.22	150	110	Average
5200	97.47	98.98			37.28	7.43	46.22	150	110	Peak
5350	44.65	46.09	54	-9.35	37.34	7.47	46.25	150	110	Average
5350	53.8	55.24	74	-20.2	37.34	7.47	46.25	150	110	Peak

ANTENNA POLARITY & TEST DISTANCE: VERTICAL AT 3 M										
FREQ. (MHz)	EMISSION LEVEL (dBuV/m)	READ LEVEL (dBuV)	LIMIT (dBuV/m)	MARGIN (dB)	ANTENNA FACTOR (dB /m)	CABLE LOSS (dB)	PREAMP FACTOR (dB)	ANTENNA HEIGHT (cm)	TABLE ANGLE (Degree)	REMARK
5150	45.28	46.81	54	-8.72	37.26	7.42	46.21	100	180	Average
5150	57.25	58.78	74	-16.75	37.26	7.42	46.21	100	180	Peak
5200	82.15	83.66			37.28	7.43	46.22	100	180	Average
5200	94.13	95.64			37.28	7.43	46.22	100	180	Peak
5350	44.78	46.22	54	-9.22	37.34	7.47	46.25	100	180	Average
5350	56.07	57.51	74	-17.93	37.34	7.47	46.25	100	180	Peak

REMARKS:

1. Emission Level = Read Level+ Antenna Factor + Cable Loss- Preamp Factor
Margin value = Emission level – Limit value.
2. 5200MHz: Fundamental frequency.



CHANNEL	TX Channel 48	DETECTOR FUNCTION	Peak (PK)
FREQUENCY RANGE	1GHz ~ 40GHz		Average (AV)

ANTENNA POLARITY & TEST DISTANCE: HORIZONTAL AT 3 M										
FREQ. (MHz)	EMISSION LEVEL (dBuV/m)	READ LEVEL (dBuV)	LIMIT (dBuV/m)	MARGIN (dB)	ANTENNA FACTOR (dB /m)	CABLE LOSS (dB)	PREAMP FACTOR (dB)	ANTENNA HEIGHT (cm)	TABLE ANGLE (Degree)	REMARK
5150	49.13	50.66	54	-4.87	37.26	7.42	46.21	116	155	Average
5150	59.22	60.75	74	-14.78	37.26	7.42	46.21	116	155	Peak
5240	80.12	81.61			37.3	7.44	46.23	116	155	Average
5240	88.95	90.44			37.3	7.44	46.23	116	155	Peak
5350	48.47	49.91	54	-5.53	37.34	7.47	46.25	116	155	Average
5350	57.73	59.17	74	-16.27	37.34	7.47	46.25	116	155	Peak

ANTENNA POLARITY & TEST DISTANCE: VERTICAL AT 3 M										
FREQ. (MHz)	EMISSION LEVEL (dBuV/m)	READ LEVEL (dBuV)	LIMIT (dBuV/m)	MARGIN (dB)	ANTENNA FACTOR (dB /m)	CABLE LOSS (dB)	PREAMP FACTOR (dB)	ANTENNA HEIGHT (cm)	TABLE ANGLE (Degree)	REMARK
5150	49.35	50.88	54	-4.65	37.26	7.42	46.21	100	180	Average
5150	59.32	60.85	74	-14.68	37.26	7.42	46.21	100	180	Peak
5240	79.59	81.08			37.3	7.44	46.23	100	180	Average
5240	88.45	89.94			37.3	7.44	46.23	100	180	Peak
5350	47.6	49.04	54	-6.4	37.34	7.47	46.25	100	180	Average
5350	59.03	60.47	74	-14.97	37.34	7.47	46.25	100	180	Peak

REMARKS:

- Emission Level = Read Level+ Antenna Factor + Cable Loss- Preamp Factor
Margin value = Emission level – Limit value.
- 5240MHz: Fundamental frequency.



802.11n (40MHz)

CHANNEL	TX Channel 38	DETECTOR FUNCTION	Peak (PK)
FREQUENCY RANGE	1GHz ~ 40GHz		Average (AV)

ANTENNA POLARITY & TEST DISTANCE: HORIZONTAL AT 3 M

FREQ. (MHz)	EMISSION LEVEL (dBuV/m)	READ LEVEL (dBuV)	LIMIT (dBuV/m)	MARGIN (dB)	ANTENNA FACTOR (dB /m)	CABLE LOSS (dB)	PREAMP FACTOR (dB)	ANTENNA HEIGHT (cm)	TABLE ANGLE (Degree)	REMARK
5150	46.52	48.05	54	-7.48	37.26	7.42	46.21	150	110	Average
5150	55.9	57.43	74	-18.1	37.26	7.42	46.21	150	110	Peak
5190	83.7	85.21			37.28	7.43	46.22	150	110	Average
5190	92.32	93.83			37.28	7.43	46.22	150	110	Peak
5350	43.58	45.02	54	-10.42	37.34	7.47	46.25	150	110	Average
5350	54.7	56.14	74	-19.3	37.34	7.47	46.25	150	110	Peak

ANTENNA POLARITY & TEST DISTANCE: VERTICAL AT 3 M

FREQ. (MHz)	EMISSION LEVEL (dBuV/m)	READ LEVEL (dBuV)	LIMIT (dBuV/m)	MARGIN (dB)	ANTENNA FACTOR (dB /m)	CABLE LOSS (dB)	PREAMP FACTOR (dB)	ANTENNA HEIGHT (cm)	TABLE ANGLE (Degree)	REMARK
5150	46.34	47.87	54	-7.66	37.26	7.42	46.21	100	180	Average
5150	58.48	60.01	74	-15.52	37.26	7.42	46.21	100	180	Peak
5190	86.68	88.19			37.28	7.43	46.22	100	180	Average
5190	91.86	93.37			37.28	7.43	46.22	100	180	Peak
5350	44.55	45.99	54	-9.45	37.34	7.47	46.25	100	180	Average
5350	59.1	60.54	74	-14.9	37.34	7.47	46.25	100	180	Peak

REMARKS:

- Emission Level = Read Level+ Antenna Factor + Cable Loss- Preamp Factor
Margin value = Emission level – Limit value.
- 5190MHz: Fundamental frequency.



CHANNEL	TX Channel 46	DETECTOR FUNCTION	Peak (PK)
FREQUENCY RANGE	1GHz ~ 40GHz		Average (AV)

ANTENNA POLARITY & TEST DISTANCE: HORIZONTAL AT 3 M

FREQ. (MHz)	EMISSION LEVEL (dBuV/m)	READ LEVEL (dBuV)	LIMIT (dBuV/m)	MARGIN (dB)	ANTENNA FACTOR (dB /m)	CABLE LOSS (dB)	PREAMP FACTOR (dB)	ANTENNA HEIGHT (cm)	TABLE ANGLE (Degree)	REMARK
5150	48.79	50.32	54	-5.21	37.26	7.42	46.21	110	140	Average
5150	60.42	61.95	74	-13.58	37.26	7.42	46.21	110	140	Peak
5230	82.15	83.65			37.29	7.44	46.23	110	140	Average
5230	92.22	93.72			37.29	7.44	46.23	110	140	Peak
5350	47.95	49.39	54	-6.05	37.34	7.47	46.25	110	140	Average
5350	58.63	60.07	74	-15.37	37.34	7.47	46.25	110	140	Peak

ANTENNA POLARITY & TEST DISTANCE: VERTICAL AT 3 M

FREQ. (MHz)	EMISSION LEVEL (dBuV/m)	READ LEVEL (dBuV)	LIMIT (dBuV/m)	MARGIN (dB)	ANTENNA FACTOR (dB /m)	CABLE LOSS (dB)	PREAMP FACTOR (dB)	ANTENNA HEIGHT (cm)	TABLE ANGLE (Degree)	REMARK
5150	48.25	49.78	54	-5.75	37.26	7.42	46.21	100	190	Average
5150	58.51	60.04	74	-15.49	37.26	7.42	46.21	100	190	Peak
5230	84.12	85.62			37.29	7.44	46.23	100	190	Average
5230	91.57	93.07			37.29	7.44	46.23	100	190	Peak
5350	47.6	49.04	54	-6.4	37.34	7.47	46.25	100	190	Average
5350	57.97	59.41	74	-16.03	37.34	7.47	46.25	100	190	Peak

REMARKS:

1. Emission Level = Read Level+ Antenna Factor + Cable Loss- Preamp Factor
Margin value = Emission level – Limit value.
2. 5230MHz: Fundamental frequency.



802.11ac (80MHz)

CHANNEL	TX Channel 42	DETECTOR FUNCTION	Peak (PK)
FREQUENCY RANGE	1GHz ~ 40GHz		Average (AV)

ANTENNA POLARITY & TEST DISTANCE: HORIZONTAL AT 3 M

FREQ. (MHz)	EMISSION LEVEL (dBuV/m)	READ LEVEL (dBuV)	LIMIT (dBuV/m)	MARGIN (dB)	ANTENNA FACTOR (dB /m)	CABLE LOSS (dB)	PREAMP FACTOR (dB)	ANTENNA HEIGHT (cm)	TABLE ANGLE (Degree)	REMARK
5150	48.33	49.86	54	-5.67	37.26	7.42	46.21	140	111	Average
5150	58.38	59.91	74	-15.62	37.26	7.42	46.21	140	111	Peak
5210	83.67	85.17			37.28	7.44	46.22	140	111	Average
5210	92.56	94.06			37.28	7.44	46.22	140	111	Peak
5350	46.58	48.02	54	-7.42	37.34	7.47	46.25	140	111	Average
5350	59.25	60.69	74	-14.75	37.34	7.47	46.25	140	111	Peak

ANTENNA POLARITY & TEST DISTANCE: VERTICAL AT 3 M

FREQ. (MHz)	EMISSION LEVEL (dBuV/m)	READ LEVEL (dBuV)	LIMIT (dBuV/m)	MARGIN (dB)	ANTENNA FACTOR (dB /m)	CABLE LOSS (dB)	PREAMP FACTOR (dB)	ANTENNA HEIGHT (cm)	TABLE ANGLE (Degree)	REMARK
5150	47.28	48.81	54	-6.72	37.26	7.42	46.21	100	180	Average
5150	59.24	60.77	74	-14.76	37.26	7.42	46.21	100	180	Peak
5210	81.53	83.03			37.28	7.44	46.22	100	180	Average
5210	92.09	93.59			37.28	7.44	46.22	100	180	Peak
5350	46.58	48.02	54	-7.42	37.34	7.47	46.25	100	180	Average
5350	58.5	59.94	74	-15.5	37.34	7.47	46.25	100	180	Peak

REMARKS:

- Emission Level = Read Level+ Antenna Factor + Cable Loss- Preamp Factor
Margin value = Emission level – Limit value.
- 5210MHz: Fundamental frequency.



Band 2
802.11a

CHANNEL	TX Channel 52	DETECTOR FUNCTION	Peak (PK)
FREQUENCY RANGE	1GHz ~ 40GHz		Average (AV)

ANTENNA POLARITY & TEST DISTANCE: HORIZONTAL AT 3 M										
FREQ. (MHz)	EMISSION LEVEL (dBuV/m)	READ LEVEL (dBuV)	LIMIT (dBuV/m)	MARGIN (dB)	ANTENNA FACTOR (dB /m)	CABLE LOSS (dB)	PREAMP FACTOR (dB)	ANTENNA HEIGHT (cm)	TABLE ANGLE (Degree)	REMARK
5150	45.78	47.31	54	-8.22	37.26	7.42	46.21	100	160	Average
5150	55.48	57.01	74	-18.52	37.26	7.42	46.21	100	160	Peak
5260	86.61	88.09			37.3	7.45	46.23	100	160	Average
5260	96.63	98.11			37.3	7.45	46.23	100	160	Peak
5350	43.93	45.37	54	-10.07	37.34	7.47	46.25	100	160	Average
5350	54.98	56.42	74	-19.02	37.34	7.47	46.25	100	160	Peak
ANTENNA POLARITY & TEST DISTANCE: VERTICAL AT 3 M										
FREQ. (MHz)	EMISSION LEVEL (dBuV/m)	READ LEVEL (dBuV)	LIMIT (dBuV/m)	MARGIN (dB)	ANTENNA FACTOR (dB /m)	CABLE LOSS (dB)	PREAMP FACTOR (dB)	ANTENNA HEIGHT (cm)	TABLE ANGLE (Degree)	REMARK
5150	47.81	49.34	54	-6.19	37.26	7.42	46.21	100	180	Average
5150	56.26	57.79	74	-17.74	37.26	7.42	46.21	100	180	Peak
5260	85.64	87.12			37.3	7.45	46.23	100	180	Average
5260	98.27	99.75			37.3	7.45	46.23	100	180	Peak
5350	45.59	47.03	54	-8.41	37.34	7.47	46.25	100	180	Average
5350	55.43	56.87	74	-18.57	37.34	7.47	46.25	100	180	Peak

REMARKS:

1. Emission Level = Read Level+ Antenna Factor + Cable Loss- Preamp Factor
Margin value = Emission level – Limit value.
2. 5260MHz: Fundamental frequency.



CHANNEL	TX Channel 60	DETECTOR FUNCTION	Peak (PK)
FREQUENCY RANGE	1GHz ~ 40GHz		Average (AV)

ANTENNA POLARITY & TEST DISTANCE: HORIZONTAL AT 3 M

FREQ. (MHz)	EMISSION LEVEL (dBuV/m)	READ LEVEL (dBuV)	LIMIT (dBuV/m)	MARGIN (dB)	ANTENNA FACTOR (dB /m)	CABLE LOSS (dB)	PREAMP FACTOR (dB)	ANTENNA HEIGHT (cm)	TABLE ANGLE (Degree)	REMARK
5150	46.48	48.01	54	-7.52	37.26	7.42	46.21	100	160	Average
5150	56.72	58.25	74	-17.28	37.26	7.42	46.21	100	160	Peak
5300	85.08	86.54			37.32	7.46	46.24	100	160	Average
5300	94.47	95.93			37.32	7.46	46.24	100	160	Peak
5350	45.88	47.32	54	-8.12	37.34	7.47	46.25	100	160	Average
5350	58.97	60.41	74	-15.03	37.34	7.47	46.25	100	160	Peak

ANTENNA POLARITY & TEST DISTANCE: VERTICAL AT 3 M

FREQ. (MHz)	EMISSION LEVEL (dBuV/m)	READ LEVEL (dBuV)	LIMIT (dBuV/m)	MARGIN (dB)	ANTENNA FACTOR (dB /m)	CABLE LOSS (dB)	PREAMP FACTOR (dB)	ANTENNA HEIGHT (cm)	TABLE ANGLE (Degree)	REMARK
5150	48.1	49.63	54	-5.9	37.26	7.42	46.21	100	180	Average
5150	59	60.53	74	-15	37.26	7.42	46.21	100	180	Peak
5300	84.22	85.68			37.32	7.46	46.24	100	180	Average
5300	97.2	98.66			37.32	7.46	46.24	100	180	Peak
5350	46.64	48.08	54	-7.36	37.34	7.47	46.25	100	180	Average
5350	59.11	60.55	74	-14.89	37.34	7.47	46.25	100	180	Peak

REMARKS:

- Emission Level = Read Level+ Antenna Factor + Cable Loss- Preamp Factor
Margin value = Emission level – Limit value.
- 5300MHz: Fundamental frequency.



CHANNEL	TX Channel 64	DETECTOR FUNCTION	Peak (PK)
FREQUENCY RANGE	1GHz ~ 40GHz		Average (AV)

ANTENNA POLARITY & TEST DISTANCE: HORIZONTAL AT 3 M										
FREQ. (MHz)	EMISSION LEVEL (dBuV/m)	READ LEVEL (dBuV)	LIMIT (dBuV/m)	MARGIN (dB)	ANTENNA FACTOR (dB /m)	CABLE LOSS (dB)	PREAMP FACTOR (dB)	ANTENNA HEIGHT (cm)	TABLE ANGLE (Degree)	REMARK
5150	48.71	50.24	54	-5.29	37.26	7.42	46.21	110	160	Average
5150	60.3	61.83	74	-13.7	37.26	7.42	46.21	110	160	Peak
5320	85.92	87.37			37.33	7.46	46.24	110	160	Average
5320	96.07	97.52			37.33	7.46	46.24	110	160	Peak
5350	47.37	48.81	54	-6.63	37.34	7.47	46.25	110	160	Average
5350	58.89	60.33	74	-15.11	37.34	7.47	46.25	110	160	Peak
ANTENNA POLARITY & TEST DISTANCE: VERTICAL AT 3 M										
FREQ. (MHz)	EMISSION LEVEL (dBuV/m)	READ LEVEL (dBuV)	LIMIT (dBuV/m)	MARGIN (dB)	ANTENNA FACTOR (dB /m)	CABLE LOSS (dB)	PREAMP FACTOR (dB)	ANTENNA HEIGHT (cm)	TABLE ANGLE (Degree)	REMARK
5150	48.11	49.64	54	-5.89	37.26	7.42	46.21	100	205	Average
5150	64.04	65.57	74	-9.96	37.26	7.42	46.21	100	205	Peak
5320	81.92	83.37			37.33	7.46	46.24	100	205	Average
5320	96.18	97.63			37.33	7.46	46.24	100	205	Peak
5350	49.5	50.94	54	-4.5	37.34	7.47	46.25	100	205	Average
5350	62.19	63.63	74	-11.81	37.34	7.47	46.25	100	205	Peak

REMARKS:

- Emission Level = Read Level+ Antenna Factor + Cable Loss- Preamp Factor
Margin value = Emission level – Limit value.
- 5320MHz: Fundamental frequency.



802.11n (20MHz)

CHANNEL	TX Channel 52	DETECTOR FUNCTION	Peak (PK)
FREQUENCY RANGE	1GHz ~ 40GHz		Average (AV)

ANTENNA POLARITY & TEST DISTANCE: HORIZONTAL AT 3 M										
FREQ. (MHz)	EMISSION LEVEL (dBuV/m)	READ LEVEL (dBuV)	LIMIT (dBuV/m)	MARGIN (dB)	ANTENNA FACTOR (dB /m)	CABLE LOSS (dB)	PREAMP FACTOR (dB)	ANTENNA HEIGHT (cm)	TABLE ANGLE (Degree)	REMARK
5150	47.98	49.51	54	-6.02	37.26	7.42	46.21	140	108	Average
5150	57.48	59.01	74	-16.52	37.26	7.42	46.21	140	108	Peak
5260	85.26	86.74			37.3	7.45	46.23	140	108	Average
5260	95.54	97.02			37.3	7.45	46.23	140	108	Peak
5350	46.58	48.02	54	-7.42	37.34	7.47	46.25	140	108	Average
5350	56.17	57.61	74	-17.83	37.34	7.47	46.25	140	108	Peak

ANTENNA POLARITY & TEST DISTANCE: VERTICAL AT 3 M										
FREQ. (MHz)	EMISSION LEVEL (dBuV/m)	READ LEVEL (dBuV)	LIMIT (dBuV/m)	MARGIN (dB)	ANTENNA FACTOR (dB /m)	CABLE LOSS (dB)	PREAMP FACTOR (dB)	ANTENNA HEIGHT (cm)	TABLE ANGLE (Degree)	REMARK
5150	48.2	49.73	54	-5.8	37.26	7.42	46.21	100	180	Average
5150	60.68	62.21	74	-13.32	37.26	7.42	46.21	100	180	Peak
5260	84.51	85.99			37.3	7.45	46.23	100	180	Average
5260	95.74	97.22			37.3	7.45	46.23	100	180	Peak
5350	47.51	48.95	54	-6.49	37.34	7.47	46.25	100	180	Average
5350	58.88	60.32	74	-15.12	37.34	7.47	46.25	100	180	Peak

REMARKS:

- Emission Level = Read Level+ Antenna Factor + Cable Loss- Preamp Factor
Margin value = Emission level – Limit value.
- 5260MHz: Fundamental frequency.



CHANNEL	TX Channel 60	DETECTOR FUNCTION	Peak (PK)
FREQUENCY RANGE	1GHz ~ 40GHz		Average (AV)

ANTENNA POLARITY & TEST DISTANCE: HORIZONTAL AT 3 M										
FREQ. (MHz)	EMISSION LEVEL (dBuV/m)	READ LEVEL (dBuV)	LIMIT (dBuV/m)	MARGIN (dB)	ANTENNA FACTOR (dB /m)	CABLE LOSS (dB)	PREAMP FACTOR (dB)	ANTENNA HEIGHT (cm)	TABLE ANGLE (Degree)	REMARK
5150	46.95	48.48	54	-7.05	37.26	7.42	46.21	110	156	Average
5150	56.82	58.35	74	-17.18	37.26	7.42	46.21	110	156	Peak
5300	83.5	84.96			37.32	7.46	46.24	110	156	Average
5300	94.58	96.04			37.32	7.46	46.24	110	156	Peak
5350	45.73	47.17	54	-8.27	37.34	7.47	46.25	110	156	Average
5350	54.6	56.04	74	-19.4	37.34	7.47	46.25	110	156	Peak

ANTENNA POLARITY & TEST DISTANCE: VERTICAL AT 3 M										
FREQ. (MHz)	EMISSION LEVEL (dBuV/m)	READ LEVEL (dBuV)	LIMIT (dBuV/m)	MARGIN (dB)	ANTENNA FACTOR (dB /m)	CABLE LOSS (dB)	PREAMP FACTOR (dB)	ANTENNA HEIGHT (cm)	TABLE ANGLE (Degree)	REMARK
5150	48.31	49.84	54	-5.69	37.26	7.42	46.21	100	186	Average
5150	63.48	65.01	74	-10.52	37.26	7.42	46.21	100	186	Peak
5300	82.38	83.84			37.32	7.46	46.24	100	186	Average
5300	93.2	94.66			37.32	7.46	46.24	100	186	Peak
5350	47.57	49.01	54	-6.43	37.34	7.47	46.25	100	186	Average
5350	60.33	61.77	74	-13.67	37.34	7.47	46.25	100	186	Peak

REMARKS:

- Emission Level = Read Level+ Antenna Factor + Cable Loss- Preamp Factor
Margin value = Emission level – Limit value.
- 5300MHz: Fundamental frequency.



CHANNEL	TX Channel 64	DETECTOR FUNCTION	Peak (PK)
FREQUENCY RANGE	1GHz ~ 40GHz		Average (AV)

ANTENNA POLARITY & TEST DISTANCE: HORIZONTAL AT 3 M

FREQ. (MHz)	EMISSION LEVEL (dBuV/m)	READ LEVEL (dBuV)	LIMIT (dBuV/m)	MARGIN (dB)	ANTENNA FACTOR (dB /m)	CABLE LOSS (dB)	PREAMP FACTOR (dB)	ANTENNA HEIGHT (cm)	TABLE ANGLE (Degree)	REMARK
5150	47.04	48.57	54	-6.96	37.26	7.42	46.21	100	160	Average
5150	59.29	60.82	74	-14.71	37.26	7.42	46.21	100	160	Peak
5320	80.88	82.33			37.33	7.46	46.24	100	160	Average
5320	93.06	94.51			37.33	7.46	46.24	100	160	Peak
5350	48.95	50.39	54	-5.05	37.34	7.47	46.25	100	160	Average
5350	59.59	61.03	74	-14.41	37.34	7.47	46.25	100	160	Peak

ANTENNA POLARITY & TEST DISTANCE: VERTICAL AT 3 M

FREQ. (MHz)	EMISSION LEVEL (dBuV/m)	READ LEVEL (dBuV)	LIMIT (dBuV/m)	MARGIN (dB)	ANTENNA FACTOR (dB /m)	CABLE LOSS (dB)	PREAMP FACTOR (dB)	ANTENNA HEIGHT (cm)	TABLE ANGLE (Degree)	REMARK
5150	49.6	51.13	54	-4.4	37.26	7.42	46.21	100	200	Average
5150	61.7	63.23	74	-12.3	37.26	7.42	46.21	100	200	Peak
5320	90.24	91.69			37.33	7.46	46.24	100	200	Average
5320	98.78	100.23			37.33	7.46	46.24	100	200	Peak
5350	47.08	48.52	54	-6.92	37.34	7.47	46.25	100	200	Average
5350	59.44	60.88	74	-14.56	37.34	7.47	46.25	100	200	Peak

REMARKS:

- Emission Level = Read Level+ Antenna Factor + Cable Loss- Preamp Factor
Margin value = Emission level – Limit value.
- 5320MHz: Fundamental frequency.



802.11n (40MHz)

CHANNEL	TX Channel 54	DETECTOR FUNCTION	Peak (PK)
FREQUENCY RANGE	1GHz ~ 40GHz		Average (AV)

ANTENNA POLARITY & TEST DISTANCE: HORIZONTAL AT 3 M										
FREQ. (MHz)	EMISSION LEVEL (dBuV/m)	READ LEVEL (dBuV)	LIMIT (dBuV/m)	MARGIN (dB)	ANTENNA FACTOR (dB /m)	CABLE LOSS (dB)	PREAMP FACTOR (dB)	ANTENNA HEIGHT (cm)	TABLE ANGLE (Degree)	REMARK
5150	48.21	49.74	54	-5.79	37.26	7.42	46.21	100	155	Average
5150	57.89	59.42	74	-16.11	37.26	7.42	46.21	100	155	Peak
5270	86.49	87.96			37.31	7.45	46.23	100	155	Average
5270	95.13	96.6			37.31	7.45	46.23	100	155	Peak
5350	47.19	48.63	54	-6.81	37.34	7.47	46.25	100	155	Average
5350	57.47	58.91	74	-16.53	37.34	7.47	46.25	100	155	Peak

ANTENNA POLARITY & TEST DISTANCE: VERTICAL AT 3 M										
FREQ. (MHz)	EMISSION LEVEL (dBuV/m)	READ LEVEL (dBuV)	LIMIT (dBuV/m)	MARGIN (dB)	ANTENNA FACTOR (dB /m)	CABLE LOSS (dB)	PREAMP FACTOR (dB)	ANTENNA HEIGHT (cm)	TABLE ANGLE (Degree)	REMARK
5150	47.56	49.09	54	-6.44	37.26	7.42	46.21	100	186	Average
5150	57.15	58.68	74	-16.85	37.26	7.42	46.21	100	186	Peak
5270	88.03	89.5			37.31	7.45	46.23	100	186	Average
5270	96.03	97.5			37.31	7.45	46.23	100	186	Peak
5350	46.58	48.02	54	-7.42	37.34	7.47	46.25	100	186	Average
5350	56.97	58.41	74	-17.03	37.34	7.47	46.25	100	186	Peak

REMARKS:

- Emission Level = Read Level+ Antenna Factor + Cable Loss- Preamp Factor
Margin value = Emission level – Limit value.
- 5270MHz: Fundamental frequency.



CHANNEL	TX Channel 62	DETECTOR FUNCTION	Peak (PK)
FREQUENCY RANGE	1GHz ~ 40GHz		Average (AV)

ANTENNA POLARITY & TEST DISTANCE: HORIZONTAL AT 3 M										
FREQ. (MHz)	EMISSION LEVEL (dBuV/m)	READ LEVEL (dBuV)	LIMIT (dBuV/m)	MARGIN (dB)	ANTENNA FACTOR (dB /m)	CABLE LOSS (dB)	PREAMP FACTOR (dB)	ANTENNA HEIGHT (cm)	TABLE ANGLE (Degree)	REMARK
5150	47.25	48.78	54	-6.75	37.26	7.42	46.21	110	160	Average
5150	57.11	58.64	74	-16.89	37.26	7.42	46.21	110	160	Peak
5310	81.67	83.13			37.32	7.46	46.24	110	160	Average
5310	89.82	91.28			37.32	7.46	46.24	110	160	Peak
5350	44.8	46.24	54	-9.2	37.34	7.47	46.25	110	160	Average
5350	55.97	57.41	74	-18.03	37.34	7.47	46.25	110	160	Peak

ANTENNA POLARITY & TEST DISTANCE: VERTICAL AT 3 M										
FREQ. (MHz)	EMISSION LEVEL (dBuV/m)	READ LEVEL (dBuV)	LIMIT (dBuV/m)	MARGIN (dB)	ANTENNA FACTOR (dB /m)	CABLE LOSS (dB)	PREAMP FACTOR (dB)	ANTENNA HEIGHT (cm)	TABLE ANGLE (Degree)	REMARK
5150	44.21	45.74	54	-9.79	37.26	7.42	46.21	100	200	Average
5150	55.13	56.66	74	-18.87	37.26	7.42	46.21	100	200	Peak
5310	76.26	77.72			37.32	7.46	46.24	100	200	Average
5310	89.29	90.75			37.32	7.46	46.24	100	200	Peak
5350	45.39	46.83	54	-8.61	37.34	7.47	46.25	100	200	Average
5350	53.85	55.29	74	-20.15	37.34	7.47	46.25	100	200	Peak

REMARKS:

- Emission Level = Read Level+ Antenna Factor + Cable Loss- Preamp Factor
Margin value = Emission level – Limit value.
- 5310MHz: Fundamental frequency.



802.11ac (80MHz)

CHANNEL	TX Channel 58	DETECTOR FUNCTION	Peak (PK)
FREQUENCY RANGE	1GHz ~ 40GHz		Average (AV)

ANTENNA POLARITY & TEST DISTANCE: HORIZONTAL AT 3 M

FREQ. (MHz)	EMISSION LEVEL (dBuV/m)	READ LEVEL (dBuV)	LIMIT (dBuV/m)	MARGIN (dB)	ANTENNA FACTOR (dB /m)	CABLE LOSS (dB)	PREAMP FACTOR (dB)	ANTENNA HEIGHT (cm)	TABLE ANGLE (Degree)	REMARK
5150	48.12	49.65	54	-5.88	37.26	7.42	46.21	150	110	Average
5150	57.73	59.26	74	-16.27	37.26	7.42	46.21	150	110	Peak
5290	78.95	80.42			37.32	7.45	46.24	150	110	Average
5290	88.74	90.21			37.32	7.45	46.24	150	110	Peak
5350	47.57	49.01	54	-6.43	37.34	7.47	46.25	150	110	Average
5350	56.79	58.23	74	-17.21	37.34	7.47	46.25	150	110	Peak

ANTENNA POLARITY & TEST DISTANCE: VERTICAL AT 3 M

FREQ. (MHz)	EMISSION LEVEL (dBuV/m)	READ LEVEL (dBuV)	LIMIT (dBuV/m)	MARGIN (dB)	ANTENNA FACTOR (dB /m)	CABLE LOSS (dB)	PREAMP FACTOR (dB)	ANTENNA HEIGHT (cm)	TABLE ANGLE (Degree)	REMARK
5150	49.4	50.93	54	-4.6	37.26	7.42	46.21	100	180	Average
5150	60.05	61.58	74	-13.95	37.26	7.42	46.21	100	180	Peak
5290	80.7	82.17			37.32	7.45	46.24	100	180	Average
5290	91.22	92.69			37.32	7.45	46.24	100	180	Peak
5350	48.41	49.85	54	-5.59	37.34	7.47	46.25	100	180	Average
5350	58.98	60.42	74	-15.02	37.34	7.47	46.25	100	180	Peak

REMARKS:

- Emission Level = Read Level+ Antenna Factor + Cable Loss- Preamp Factor
Margin value = Emission level – Limit value.
- 5290MHz: Fundamental frequency.



Band 3

802.11a

CHANNEL	TX Channel 100	DETECTOR FUNCTION	Peak (PK)
FREQUENCY RANGE	1GHz ~ 40GHz		Average (AV)

ANTENNA POLARITY & TEST DISTANCE: HORIZONTAL AT 3 M										
FREQ. (MHz)	EMISSION LEVEL (dBuV/m)	READ LEVEL (dBuV)	LIMIT (dBuV/m)	MARGIN (dB)	ANTENNA FACTOR (dB /m)	CABLE LOSS (dB)	PREAMP FACTOR (dB)	ANTENNA HEIGHT (cm)	TABLE ANGLE (Degree)	REMARK
5460	48.13	49.53	54	-5.87	37.38	7.49	46.27	130	110	Average
5460	58.15	59.55	74	-15.85	37.38	7.49	46.27	130	110	Peak
#5470	60.6	61.99	68.3	-7.7	37.39	7.49	46.27	130	110	Peak
5500	84.5	85.88			37.4	7.5	46.28	130	110	Average
5500	92.96	94.34			37.4	7.5	46.28	130	110	Peak

ANTENNA POLARITY & TEST DISTANCE: VERTICAL AT 3 M										
FREQ. (MHz)	EMISSION LEVEL (dBuV/m)	READ LEVEL (dBuV)	LIMIT (dBuV/m)	MARGIN (dB)	ANTENNA FACTOR (dB /m)	CABLE LOSS (dB)	PREAMP FACTOR (dB)	ANTENNA HEIGHT (cm)	TABLE ANGLE (Degree)	REMARK
5460	48.88	50.28	54	-5.12	37.38	7.49	46.27	100	170	Average
5460	62.94	64.34	74	-11.06	37.38	7.49	46.27	100	170	Peak
#5470	60.54	61.93	68.3	-7.76	37.39	7.49	46.27	100	170	Peak
5500	83.51	84.89			37.4	7.5	46.28	100	170	Average
5500	96.57	97.95			37.4	7.5	46.28	100	170	Peak

REMARKS:

1. Emission Level = Read Level+ Antenna Factor + Cable Loss- Preamp Factor
Margin value = Emission level – Limit value.
2. 5500MHz: Fundamental frequency.
3. #: Out of restricted band.



CHANNEL	TX Channel 116	DETECTOR FUNCTION	Peak (PK)
FREQUENCY RANGE	1GHz ~ 40GHz		Average (AV)

ANTENNA POLARITY & TEST DISTANCE: HORIZONTAL AT 3 M										
FREQ. (MHz)	EMISSION LEVEL (dBuV/m)	READ LEVEL (dBuV)	LIMIT (dBuV/m)	MARGIN (dB)	ANTENNA FACTOR (dB /m)	CABLE LOSS (dB)	PREAMP FACTOR (dB)	ANTENNA HEIGHT (cm)	TABLE ANGLE (Degree)	REMARK
5460	48.37	49.77	54	-5.63	37.38	7.49	46.27	130	110	Average
5460	57.26	58.66	74	-16.74	37.38	7.49	46.27	130	110	Peak
#5470	59.82	61.21	68.3	-8.48	37.39	7.49	46.27	130	110	Peak
5580	83.43	84.68			37.45	7.58	46.28	130	110	Average
5580	95.67	96.92			37.45	7.58	46.28	130	110	Peak

ANTENNA POLARITY & TEST DISTANCE: VERTICAL AT 3 M										
FREQ. (MHz)	EMISSION LEVEL (dBuV/m)	READ LEVEL (dBuV)	LIMIT (dBuV/m)	MARGIN (dB)	ANTENNA FACTOR (dB /m)	CABLE LOSS (dB)	PREAMP FACTOR (dB)	ANTENNA HEIGHT (cm)	TABLE ANGLE (Degree)	REMARK
5460	47.87	49.27	54	-6.13	37.38	7.49	46.27	100	180	Average
5460	58.71	60.11	74	-15.29	37.38	7.49	46.27	100	180	Peak
#5470	61.19	62.58	68.3	-7.11	37.39	7.49	46.27	100	180	Peak
5580	84.46	85.71			37.45	7.58	46.28	100	180	Average
5580	95.36	96.61			37.45	7.58	46.28	100	180	Peak

REMARKS:

1. Emission Level = Read Level+ Antenna Factor + Cable Loss- Preamp Factor
Margin value = Emission level – Limit value.
2. 5580MHz: Fundamental frequency.
3. #: Out of restricted band.



CHANNEL	TX Channel 140	DETECTOR FUNCTION	Peak (PK)
FREQUENCY RANGE	1GHz ~ 40GHz		Average (AV)

ANTENNA POLARITY & TEST DISTANCE: HORIZONTAL AT 3 M										
FREQ. (MHz)	EMISSION LEVEL (dBuV/m)	READ LEVEL (dBuV)	LIMIT (dBuV/m)	MARGIN (dB)	ANTENNA FACTOR (dB /m)	CABLE LOSS (dB)	PREAMP FACTOR (dB)	ANTENNA HEIGHT (cm)	TABLE ANGLE (Degree)	REMARK
5700	86.73	87.79			37.52	7.7	46.28	100	190	Average
5700	96.29	97.35			37.52	7.7	46.28	100	190	Peak
#5725	63.17	64.19	68.3	-5.13	37.53	7.73	46.28	100	190	Peak
ANTENNA POLARITY & TEST DISTANCE: VERTICAL AT 3 M										
FREQ. (MHz)	EMISSION LEVEL (dBuV/m)	READ LEVEL (dBuV)	LIMIT (dBuV/m)	MARGIN (dB)	ANTENNA FACTOR (dB /m)	CABLE LOSS (dB)	PREAMP FACTOR (dB)	ANTENNA HEIGHT (cm)	TABLE ANGLE (Degree)	REMARK
5700	82.5	83.56			37.52	7.7	46.28	110	160	Average
5700	95.66	96.72			37.52	7.7	46.28	110	160	Peak
#5725	62.21	63.23	68.3	-6.09	37.53	7.73	46.28	110	160	Peak

REMARKS:

- Emission Level = Read Level+ Antenna Factor + Cable Loss- Preamp Factor
Margin value = Emission level – Limit value.
- 5700MHz: Fundamental frequency.
- #: Out of restricted band.



802.11n (20MHz)

CHANNEL	TX Channel 100	DETECTOR FUNCTION	Peak (PK)
FREQUENCY RANGE	1GHz ~ 40GHz		Average (AV)

ANTENNA POLARITY & TEST DISTANCE: HORIZONTAL AT 3 M										
FREQ. (MHz)	EMISSION LEVEL (dBuV/m)	READ LEVEL (dBuV)	LIMIT (dBuV/m)	MARGIN (dB)	ANTENNA FACTOR (dB /m)	CABLE LOSS (dB)	PREAMP FACTOR (dB)	ANTENNA HEIGHT (cm)	TABLE ANGLE (Degree)	REMARK
5460	48.66	50.06	54	-5.34	37.38	7.49	46.27	130	110	Average
5460	57.61	59.01	74	-16.39	37.38	7.49	46.27	130	110	Peak
#5470	59.7	61.09	68.3	-8.6	37.39	7.49	46.27	130	110	Peak
5500	86.95	88.33			37.4	7.5	46.28	130	110	Average
5500	94.81	96.19			37.4	7.5	46.28	130	110	Peak

ANTENNA POLARITY & TEST DISTANCE: VERTICAL AT 3 M										
FREQ. (MHz)	EMISSION LEVEL (dBuV/m)	READ LEVEL (dBuV)	LIMIT (dBuV/m)	MARGIN (dB)	ANTENNA FACTOR (dB /m)	CABLE LOSS (dB)	PREAMP FACTOR (dB)	ANTENNA HEIGHT (cm)	TABLE ANGLE (Degree)	REMARK
5460	46.09	47.49	54	-7.91	37.38	7.49	46.27	100	163	Average
5460	68.83	70.23	74	-5.17	37.38	7.49	46.27	100	163	Peak
#5470	65.32	66.71	68.3	-2.98	37.39	7.49	46.27	100	163	Peak
5500	85.84	87.22			37.4	7.5	46.28	100	163	Average
5500	97.58	98.96			37.4	7.5	46.28	100	163	Peak

REMARKS:

- Emission Level = Read Level+ Antenna Factor + Cable Loss- Preamp Factor
Margin value = Emission level – Limit value.
- 5500MHz: Fundamental frequency.
- #: Out of restricted band.



CHANNEL	TX Channel 116	DETECTOR FUNCTION	Peak (PK)
FREQUENCY RANGE	1GHz ~ 40GHz		Average (AV)

ANTENNA POLARITY & TEST DISTANCE: HORIZONTAL AT 3 M										
FREQ. (MHz)	EMISSION LEVEL (dBuV/m)	READ LEVEL (dBuV)	LIMIT (dBuV/m)	MARGIN (dB)	ANTENNA FACTOR (dB /m)	CABLE LOSS (dB)	PREAMP FACTOR (dB)	ANTENNA HEIGHT (cm)	TABLE ANGLE (Degree)	REMARK
5460	48.83	50.23	54	-5.17	37.38	7.49	46.27	100	110	Average
5460	56.96	58.36	74	-17.04	37.38	7.49	46.27	100	110	Peak
#5470	58.86	60.25	68.3	-9.44	37.39	7.49	46.27	100	110	Peak
5580	84.58	85.83			37.45	7.58	46.28	100	110	Average
5580	94.62	95.87			37.45	7.58	46.28	100	110	Peak

ANTENNA POLARITY & TEST DISTANCE: VERTICAL AT 3 M										
FREQ. (MHz)	EMISSION LEVEL (dBuV/m)	READ LEVEL (dBuV)	LIMIT (dBuV/m)	MARGIN (dB)	ANTENNA FACTOR (dB /m)	CABLE LOSS (dB)	PREAMP FACTOR (dB)	ANTENNA HEIGHT (cm)	TABLE ANGLE (Degree)	REMARK
5460	48.86	50.26	54	-5.14	37.38	7.49	46.27	100	180	Average
5460	59.47	60.87	74	-14.53	37.38	7.49	46.27	100	180	Peak
#5470	60.85	62.24	68.3	-7.45	37.39	7.49	46.27	100	180	Peak
5580	84.77	86.02			37.45	7.58	46.28	100	180	Average
5580	96.41	97.66			37.45	7.58	46.28	100	180	Peak

REMARKS:

- Emission Level = Read Level+ Antenna Factor + Cable Loss- Preamp Factor
Margin value = Emission level – Limit value.
- 5580MHz: Fundamental frequency.



CHANNEL	TX Channel 140	DETECTOR FUNCTION	Peak (PK)
FREQUENCY RANGE	1GHz ~ 40GHz		Average (AV)

ANTENNA POLARITY & TEST DISTANCE: HORIZONTAL AT 3 M										
FREQ. (MHz)	EMISSION LEVEL (dBuV/m)	READ LEVEL (dBuV)	LIMIT (dBuV/m)	MARGIN (dB)	ANTENNA FACTOR (dB /m)	CABLE LOSS (dB)	PREAMP FACTOR (dB)	ANTENNA HEIGHT (cm)	TABLE ANGLE (Degree)	REMARK
5700	81.05	82.11			37.52	7.7	46.28	200	80	Average
5700	92.07	93.13			37.52	7.7	46.28	200	80	Peak
#5725	64.3	65.32	68.3	-4	37.53	7.73	46.28	200	80	Peak
ANTENNA POLARITY & TEST DISTANCE: VERTICAL AT 3 M										
FREQ. (MHz)	EMISSION LEVEL (dBuV/m)	READ LEVEL (dBuV)	LIMIT (dBuV/m)	MARGIN (dB)	ANTENNA FACTOR (dB /m)	CABLE LOSS (dB)	PREAMP FACTOR (dB)	ANTENNA HEIGHT (cm)	TABLE ANGLE (Degree)	REMARK
5700	86.3	87.36			37.52	7.7	46.28	130	170	Average
5700	95.95	97.01			37.52	7.7	46.28	130	170	Peak
#5725	62.71	63.73	68.3	-5.59	37.53	7.73	46.28	130	170	Peak

REMARKS:

1. Emission Level = Read Level+ Antenna Factor + Cable Loss- Preamp Factor
Margin value = Emission level – Limit value.
2. 5700MHz: Fundamental frequency.
3. #: Out of restricted band.



802.11n (40MHz)

CHANNEL	TX Channel 102	DETECTOR FUNCTION	Peak (PK)
FREQUENCY RANGE	1GHz ~ 40GHz		Average (AV)

ANTENNA POLARITY & TEST DISTANCE: HORIZONTAL AT 3 M										
FREQ. (MHz)	EMISSION LEVEL (dBuV/m)	READ LEVEL (dBuV)	LIMIT (dBuV/m)	MARGIN (dB)	ANTENNA FACTOR (dB /m)	CABLE LOSS (dB)	PREAMP FACTOR (dB)	ANTENNA HEIGHT (cm)	TABLE ANGLE (Degree)	REMARK
5460	47.91	49.31	54	-6.09	37.38	7.49	46.27	100	190	Average
5460	57.41	58.81	74	-16.59	37.38	7.49	46.27	100	190	Peak
#5470	58.33	59.72	68.3	-9.97	37.39	7.49	46.27	100	190	Peak
5510	83.22	84.58			37.41	7.51	46.28	100	190	Average
5510	93.95	95.31			37.41	7.51	46.28	100	190	Peak

ANTENNA POLARITY & TEST DISTANCE: VERTICAL AT 3 M										
FREQ. (MHz)	EMISSION LEVEL (dBuV/m)	READ LEVEL (dBuV)	LIMIT (dBuV/m)	MARGIN (dB)	ANTENNA FACTOR (dB /m)	CABLE LOSS (dB)	PREAMP FACTOR (dB)	ANTENNA HEIGHT (cm)	TABLE ANGLE (Degree)	REMARK
5460	48.61	50.01	54	-5.39	37.38	7.49	46.27	100	160	Average
5460	58.71	60.11	74	-15.29	37.38	7.49	46.27	100	160	Peak
#5470	60.7	62.09	68.3	-7.6	37.39	7.49	46.27	100	160	Peak
5510	88.38	89.74			37.41	7.51	46.28	100	160	Average
5510	93.51	94.87			37.41	7.51	46.28	100	160	Peak

REMARKS:

- Emission Level = Read Level+ Antenna Factor + Cable Loss- Preamp Factor
Margin value = Emission level – Limit value.
- 5510MHz: Fundamental frequency.
- #: Out of restricted band.



CHANNEL	TX Channel 110	DETECTOR FUNCTION	Peak (PK)
FREQUENCY RANGE	1GHz ~ 40GHz		Average (AV)

ANTENNA POLARITY & TEST DISTANCE: HORIZONTAL AT 3 M										
FREQ. (MHz)	EMISSION LEVEL (dBuV/m)	READ LEVEL (dBuV)	LIMIT (dBuV/m)	MARGIN (dB)	ANTENNA FACTOR (dB /m)	CABLE LOSS (dB)	PREAMP FACTOR (dB)	ANTENNA HEIGHT (cm)	TABLE ANGLE (Degree)	REMARK
5460	45.83	47.23	54	-8.17	37.38	7.49	46.27	100	100	Average
5460	60.06	61.46	74	-13.94	37.38	7.49	46.27	100	100	Peak
#5470	62.2	63.59	68.3	-6.1	37.39	7.49	46.27	100	100	Peak
5550	86.77	88.07			37.43	7.55	46.28	100	100	Average
5550	94.21	95.51			37.43	7.55	46.28	100	100	Peak
ANTENNA POLARITY & TEST DISTANCE: VERTICAL AT 3 M										
FREQ. (MHz)	EMISSION LEVEL (dBuV/m)	READ LEVEL (dBuV)	LIMIT (dBuV/m)	MARGIN (dB)	ANTENNA FACTOR (dB /m)	CABLE LOSS (dB)	PREAMP FACTOR (dB)	ANTENNA HEIGHT (cm)	TABLE ANGLE (Degree)	REMARK
5460	47.29	48.69	54	-6.71	37.38	7.49	46.27	100	180	Average
5460	57.36	58.76	74	-16.64	37.38	7.49	46.27	100	180	Peak
#5470	61.17	62.56	68.3	-7.13	37.39	7.49	46.27	100	180	Peak
5550	88.58	89.88			37.43	7.55	46.28	100	180	Average
5550	96.89	98.19			37.43	7.55	46.28	100	180	Peak

REMARKS:

1. Emission Level = Read Level+ Antenna Factor + Cable Loss- Preamp Factor
Margin value = Emission level – Limit value.
2. 5550MHz: Fundamental frequency.
3. #: Out of restricted band.



CHANNEL	TX Channel 134	DETECTOR FUNCTION	Peak (PK)
FREQUENCY RANGE	1GHz ~ 40GHz		Average (AV)

ANTENNA POLARITY & TEST DISTANCE: HORIZONTAL AT 3 M										
FREQ. (MHz)	EMISSION LEVEL (dBuV/m)	READ LEVEL (dBuV)	LIMIT (dBuV/m)	MARGIN (dB)	ANTENNA FACTOR (dB /m)	CABLE LOSS (dB)	PREAMP FACTOR (dB)	ANTENNA HEIGHT (cm)	TABLE ANGLE (Degree)	REMARK
5670	88.71	89.82			37.5	7.67	46.28	110	190	Average
5670	94.82	95.93			37.5	7.67	46.28	110	190	Peak
#5725	60.1	61.12	68.3	-8.2	37.53	7.73	46.28	110	190	Peak
ANTENNA POLARITY & TEST DISTANCE: VERTICAL AT 3 M										
FREQ. (MHz)	EMISSION LEVEL (dBuV/m)	READ LEVEL (dBuV)	LIMIT (dBuV/m)	MARGIN (dB)	ANTENNA FACTOR (dB /m)	CABLE LOSS (dB)	PREAMP FACTOR (dB)	ANTENNA HEIGHT (cm)	TABLE ANGLE (Degree)	REMARK
5670	86.14	87.25			37.5	7.67	46.28	100	300	Average
5670	92.82	93.93			37.5	7.67	46.28	100	300	Peak
#5725	60.55	61.57	68.3	-7.75	37.53	7.73	46.28	100	300	Peak

REMARKS:

1. Emission Level = Read Level+ Antenna Factor + Cable Loss- Preamp Factor
Margin value = Emission level – Limit value.
2. 5670MHz: Fundamental frequency.
3. #: Out of restricted band.



802.11ac (80MHz)

CHANNEL	TX Channel 106	DETECTOR FUNCTION	Peak (PK)
FREQUENCY RANGE	1GHz ~ 40GHz		Average (AV)

ANTENNA POLARITY & TEST DISTANCE: HORIZONTAL AT 3 M										
FREQ. (MHz)	EMISSION LEVEL (dBuV/m)	READ LEVEL (dBuV)	LIMIT (dBuV/m)	MARGIN (dB)	ANTENNA FACTOR (dB /m)	CABLE LOSS (dB)	PREAMP FACTOR (dB)	ANTENNA HEIGHT (cm)	TABLE ANGLE (Degree)	REMARK
5460	48.15	49.55	54	-5.85	37.38	7.49	46.27	110	110	Average
5460	59.58	60.98	74	-14.42	37.38	7.49	46.27	110	110	Peak
#5470	60.92	62.31	68.3	-7.38	37.39	7.49	46.27	110	110	Peak
5530	82.64	83.97			37.42	7.53	46.28	110	110	Average
5530	91.66	92.99			37.42	7.53	46.28	110	110	Peak

ANTENNA POLARITY & TEST DISTANCE: VERTICAL AT 3 M										
FREQ. (MHz)	EMISSION LEVEL (dBuV/m)	READ LEVEL (dBuV)	LIMIT (dBuV/m)	MARGIN (dB)	ANTENNA FACTOR (dB /m)	CABLE LOSS (dB)	PREAMP FACTOR (dB)	ANTENNA HEIGHT (cm)	TABLE ANGLE (Degree)	REMARK
5460	49.57	50.97	54	-4.43	37.38	7.49	46.27	100	160	Average
5460	61.53	62.93	74	-12.47	37.38	7.49	46.27	100	160	Peak
#5470	63.25	64.64	68.3	-5.05	37.39	7.49	46.27	100	160	Peak
5530	83.7	85.03			37.42	7.53	46.28	100	160	Average
5530	92.04	93.37			37.42	7.53	46.28	100	160	Peak

REMARKS:

1. Emission Level = Read Level+ Antenna Factor + Cable Loss- Preamp Factor
Margin value = Emission level – Limit value.
2. 5530MHz: Fundamental frequency.
3. #: Out of restricted band.



Band 4

802.11a

CHANNEL	TX Channel 149	DETECTOR FUNCTION	Peak (PK)
FREQUENCY RANGE	1GHz ~ 40GHz		Average (AV)

ANTENNA POLARITY & TEST DISTANCE: HORIZONTAL AT 3 M										
FREQ. (MHz)	EMISSION LEVEL (dBuV/m)	READ LEVEL (dBuV)	LIMIT (dBuV/m)	MARGIN (dB)	ANTENNA FACTOR (dB /m)	CABLE LOSS (dB)	PREAMP FACTOR (dB)	ANTENNA HEIGHT (cm)	TABLE ANGLE (Degree)	REMARK
5745	85.65	86.63			37.55	7.75	46.28	120	190	Average
5745	96.35	97.33			37.55	7.75	46.28	120	190	Peak
ANTENNA POLARITY & TEST DISTANCE: VERTICAL AT 3 M										
FREQ. (MHz)	EMISSION LEVEL (dBuV/m)	READ LEVEL (dBuV)	LIMIT (dBuV/m)	MARGIN (dB)	ANTENNA FACTOR (dB /m)	CABLE LOSS (dB)	PREAMP FACTOR (dB)	ANTENNA HEIGHT (cm)	TABLE ANGLE (Degree)	REMARK
5745	87.49	88.47			37.55	7.75	46.28	120	165	Average
5745	96.13	97.11			37.55	7.75	46.28	120	165	Peak

REMARKS:

1. Emission Level = Read Level+ Antenna Factor + Cable Loss- Preamp Factor
Margin value = Emission level – Limit value.
2. 5745MHz: Fundamental frequency.



Oobe Data

802.11a

ANTENNA POLARITY & TEST DISTANCE: HORIZONTAL AT 3 M										
FREQ. (MHz)	EMISSION LEVEL (dBuV/m)	READ LEVEL (dBuV)	LIMIT (dBuV/m)	MARGIN (dB)	ANTENNA FACTOR (dB /m)	CABLE LOSS (dB)	PREAMP FACTOR (dB)	ANTENNA HEIGHT (cm)	TABLE ANGLE (Degree)	REMARK
5623.63	56.48	57.66	68.3	-11.82	37.47	7.63	46.28	100	110	Peak
5950.9	57.02	57.67	68.3	-11.28	37.67	7.96	46.28	100	110	Peak
ANTENNA POLARITY & TEST DISTANCE: VERTICAL AT 3 M										
FREQ. (MHz)	EMISSION LEVEL (dBuV/m)	READ LEVEL (dBuV)	LIMIT (dBuV/m)	MARGIN (dB)	ANTENNA FACTOR (dB /m)	CABLE LOSS (dB)	PREAMP FACTOR (dB)	ANTENNA HEIGHT (cm)	TABLE ANGLE (Degree)	REMARK
5616.03	56.07	57.26	68.3	-12.23	37.47	7.62	46.28	100	110	Peak
5958.03	56.25	56.89	68.3	-12.05	37.67	7.97	46.28	100	110	Peak

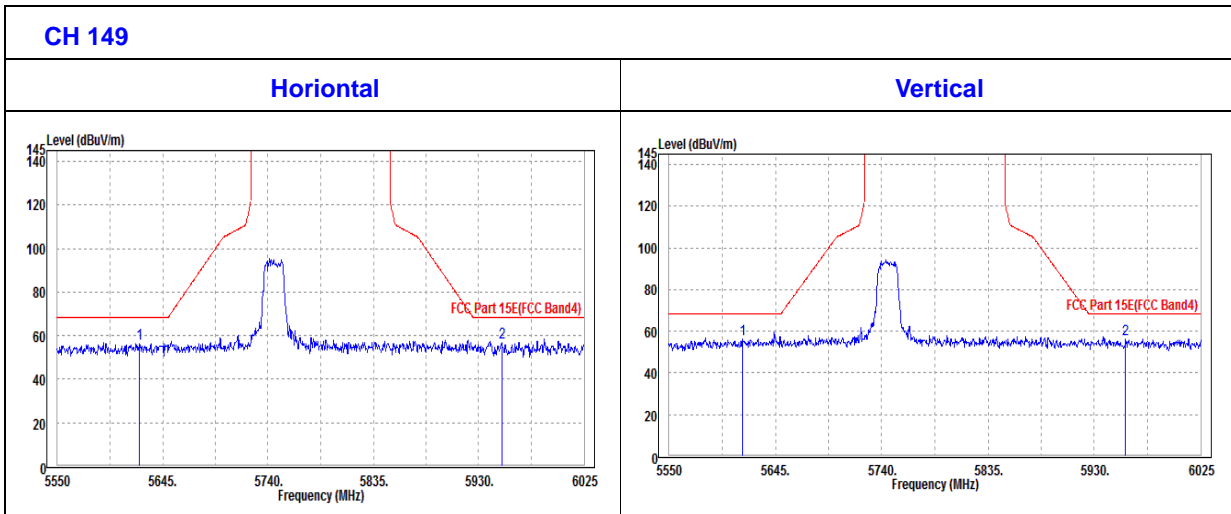



CHANNEL	TX Channel 157	DETECTOR FUNCTION	Peak (PK)
FREQUENCY RANGE	1GHz ~ 40GHz		Average (AV)

ANTENNA POLARITY & TEST DISTANCE: HORIZONTAL AT 3 M										
FREQ. (MHz)	EMISSION LEVEL (dBuV/m)	READ LEVEL (dBuV)	LIMIT (dBuV/m)	MARGIN (dB)	ANTENNA FACTOR (dB /m)	CABLE LOSS (dB)	PREAMP FACTOR (dB)	ANTENNA HEIGHT (cm)	TABLE ANGLE (Degree)	REMARK
5785	88.82	89.74			37.57	7.79	46.28	120	195	Average
5785	95.57	96.49			37.57	7.79	46.28	120	195	Peak
ANTENNA POLARITY & TEST DISTANCE: VERTICAL AT 3 M										
FREQ. (MHz)	EMISSION LEVEL (dBuV/m)	READ LEVEL (dBuV)	LIMIT (dBuV/m)	MARGIN (dB)	ANTENNA FACTOR (dB /m)	CABLE LOSS (dB)	PREAMP FACTOR (dB)	ANTENNA HEIGHT (cm)	TABLE ANGLE (Degree)	REMARK
5785	88.02	88.94			37.57	7.79	46.28	120	190	Average
5785	95.55	96.47			37.57	7.79	46.28	120	190	Peak

REMARKS:

1. Emission Level = Read Level+ Antenna Factor + Cable Loss- Preamp Factor
Margin value = Emission level – Limit value.
2. 5785MHz: Fundamental frequency.



OOBE DATA

802.11a

ANTENNA POLARITY & TEST DISTANCE: HORIZONTAL AT 3 M										
FREQ. (MHz)	EMISSION LEVEL (dBuV/m)	READ LEVEL (dBuV)	LIMIT (dBuV/m)	MARGIN (dB)	ANTENNA FACTOR (dB /m)	CABLE LOSS (dB)	PREAMP FACTOR (dB)	ANTENNA HEIGHT (cm)	TABLE ANGLE (Degree)	REMARK
5629.8	57.6	58.77	68.3	-10.7	37.48	7.63	46.28	120	195	Peak
5968	57.72	58.34	68.3	-10.58	37.68	7.98	46.28	120	195	Peak
ANTENNA POLARITY & TEST DISTANCE: VERTICAL AT 3 M										
FREQ. (MHz)	EMISSION LEVEL (dBuV/m)	READ LEVEL (dBuV)	LIMIT (dBuV/m)	MARGIN (dB)	ANTENNA FACTOR (dB /m)	CABLE LOSS (dB)	PREAMP FACTOR (dB)	ANTENNA HEIGHT (cm)	TABLE ANGLE (Degree)	REMARK
5616.03	57.73	58.92	68.3	-10.57	37.47	7.62	46.28	120	360	Peak
5982.25	58.56	59.16	68.3	-9.74	37.69	7.99	46.28	120	360	Peak

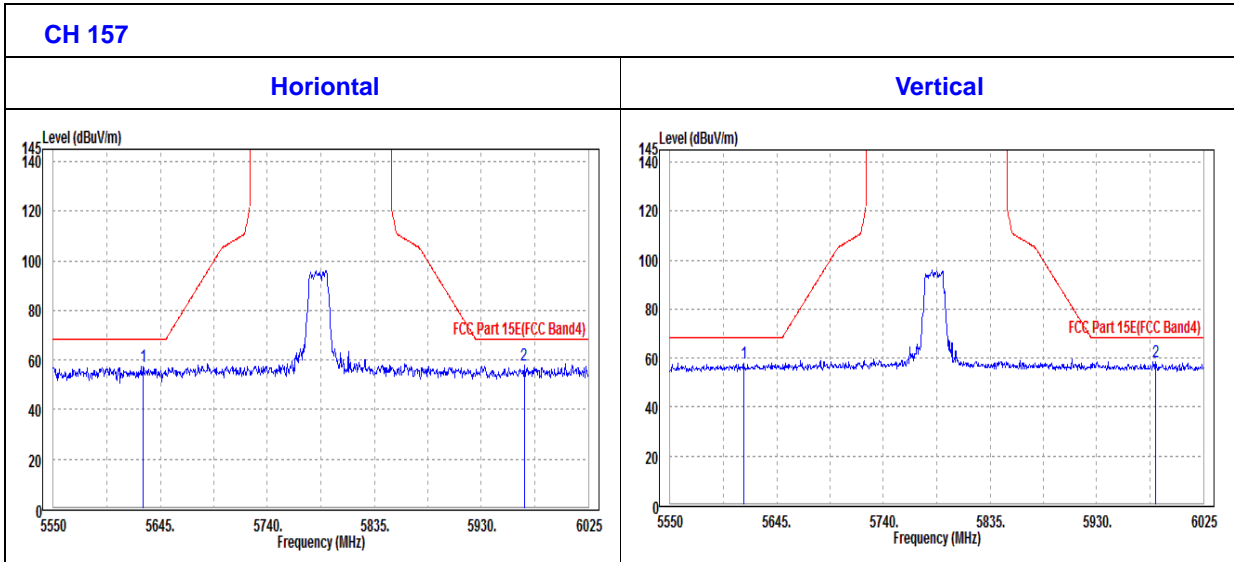



CHANNEL	TX Channel 165	DETECTOR FUNCTION	Peak (PK)
FREQUENCY RANGE	1GHz ~ 40GHz		Average (AV)

ANTENNA POLARITY & TEST DISTANCE: HORIZONTAL AT 3 M										
FREQ. (MHz)	EMISSION LEVEL (dBuV/m)	READ LEVEL (dBuV)	LIMIT (dBuV/m)	MARGIN (dB)	ANTENNA FACTOR (dB /m)	CABLE LOSS (dB)	PREAMP FACTOR (dB)	ANTENNA HEIGHT (cm)	TABLE ANGLE (Degree)	REMARK
5825	89.63	90.48			37.6	7.83	46.28	130	100	Average
5825	95.69	96.54			37.6	7.83	46.28	130	100	Peak
ANTENNA POLARITY & TEST DISTANCE: VERTICAL AT 3 M										
FREQ. (MHz)	EMISSION LEVEL (dBuV/m)	READ LEVEL (dBuV)	LIMIT (dBuV/m)	MARGIN (dB)	ANTENNA FACTOR (dB /m)	CABLE LOSS (dB)	PREAMP FACTOR (dB)	ANTENNA HEIGHT (cm)	TABLE ANGLE (Degree)	REMARK
5825	86.16	87.01			37.6	7.83	46.28	130	175	Average
5825	97.59	98.44			37.6	7.83	46.28	130	175	Peak

REMARKS:

1. Emission Level = Read Level+ Antenna Factor + Cable Loss- Preamp Factor
Margin value = Emission level – Limit value.
2. 5825MHz: Fundamental frequency.



OOBE DATA

802.11a

ANTENNA POLARITY & TEST DISTANCE: HORIZONTAL AT 3 M										
FREQ. (MHz)	EMISSION LEVEL (dBuV/m)	READ LEVEL (dBuV)	LIMIT (dBuV/m)	MARGIN (dB)	ANTENNA FACTOR (dB /m)	CABLE LOSS (dB)	PREAMP FACTOR (dB)	ANTENNA HEIGHT (cm)	TABLE ANGLE (Degree)	REMARK
5609.85	55.98	57.18	68.3	-12.32	37.47	7.61	46.28	120	0	Peak
5961.83	57.13	57.76	68.3	-11.17	37.68	7.97	46.28	120	0	Peak
ANTENNA POLARITY & TEST DISTANCE: VERTICAL AT 3 M										
FREQ. (MHz)	EMISSION LEVEL (dBuV/m)	READ LEVEL (dBuV)	LIMIT (dBuV/m)	MARGIN (dB)	ANTENNA FACTOR (dB /m)	CABLE LOSS (dB)	PREAMP FACTOR (dB)	ANTENNA HEIGHT (cm)	TABLE ANGLE (Degree)	REMARK
5617.93	57.62	58.81	68.3	-10.68	37.47	7.62	46.28	120	0	Peak
5955.65	57.53	58.18	68.3	-10.77	37.67	7.96	46.28	120	0	Peak

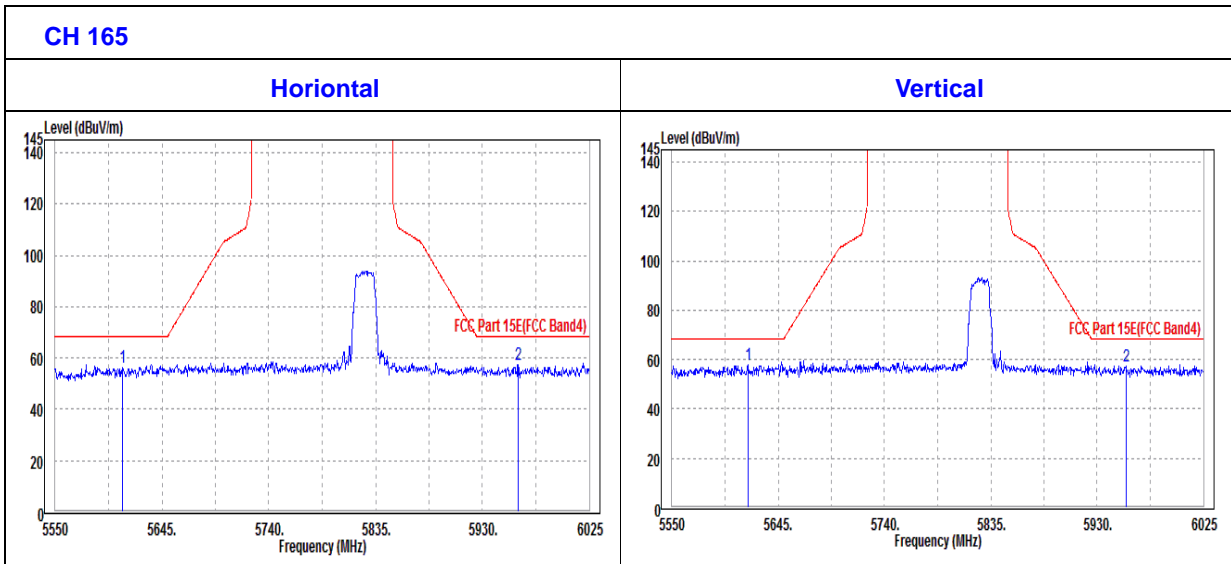



802.11n (20MHz)

CHANNEL	TX Channel 149	DETECTOR FUNCTION	Peak (PK)
FREQUENCY RANGE	1GHz ~ 40GHz		Average (AV)

ANTENNA POLARITY & TEST DISTANCE: HORIZONTAL AT 3 M										
FREQ. (MHz)	EMISSION LEVEL (dBuV/m)	READ LEVEL (dBuV)	LIMIT (dBuV/m)	MARGIN (dB)	ANTENNA FACTOR (dB /m)	CABLE LOSS (dB)	PREAMP FACTOR (dB)	ANTENNA HEIGHT (cm)	TABLE ANGLE (Degree)	REMARK
5745	86.65	87.63			37.55	7.75	46.28	120	180	Average
5745	95.35	96.33			37.55	7.75	46.28	120	180	Peak
ANTENNA POLARITY & TEST DISTANCE: VERTICAL AT 3 M										
FREQ. (MHz)	EMISSION LEVEL (dBuV/m)	READ LEVEL (dBuV)	LIMIT (dBuV/m)	MARGIN (dB)	ANTENNA FACTOR (dB /m)	CABLE LOSS (dB)	PREAMP FACTOR (dB)	ANTENNA HEIGHT (cm)	TABLE ANGLE (Degree)	REMARK
5745	87.49	88.47			37.55	7.75	46.28	100	165	Average
5745	96.13	97.11			37.55	7.75	46.28	100	165	Peak

REMARKS:

1. Emission Level = Read Level+ Antenna Factor + Cable Loss- Preamp Factor
Margin value = Emission level – Limit value.
2. 5745MHz: Fundamental frequency.



OOBE DATA

802.11n (20MHZ)

ANTENNA POLARITY & TEST DISTANCE: HORIZONTAL AT 3 M										
FREQ. (MHz)	EMISSION LEVEL (dBuV/m)	READ LEVEL (dBuV)	LIMIT (dBuV/m)	MARGIN (dB)	ANTENNA FACTOR (dB /m)	CABLE LOSS (dB)	PREAMP FACTOR (dB)	ANTENNA HEIGHT (cm)	TABLE ANGLE (Degree)	REMARK
5603.2	57.23	58.44	68.3	-11.07	37.46	7.61	46.28	130	175	Peak
5969.9	57.37	57.99	68.3	-10.93	37.68	7.98	46.28	130	175	Peak
ANTENNA POLARITY & TEST DISTANCE: VERTICAL AT 3 M										
FREQ. (MHz)	EMISSION LEVEL (dBuV/m)	READ LEVEL (dBuV)	LIMIT (dBuV/m)	MARGIN (dB)	ANTENNA FACTOR (dB /m)	CABLE LOSS (dB)	PREAMP FACTOR (dB)	ANTENNA HEIGHT (cm)	TABLE ANGLE (Degree)	REMARK
5612.7	57.65	58.85	68.3	-10.65	37.47	7.61	46.28	130	175	Peak
5950.9	56.91	57.56	68.3	-11.39	37.67	7.96	46.28	130	175	Peak

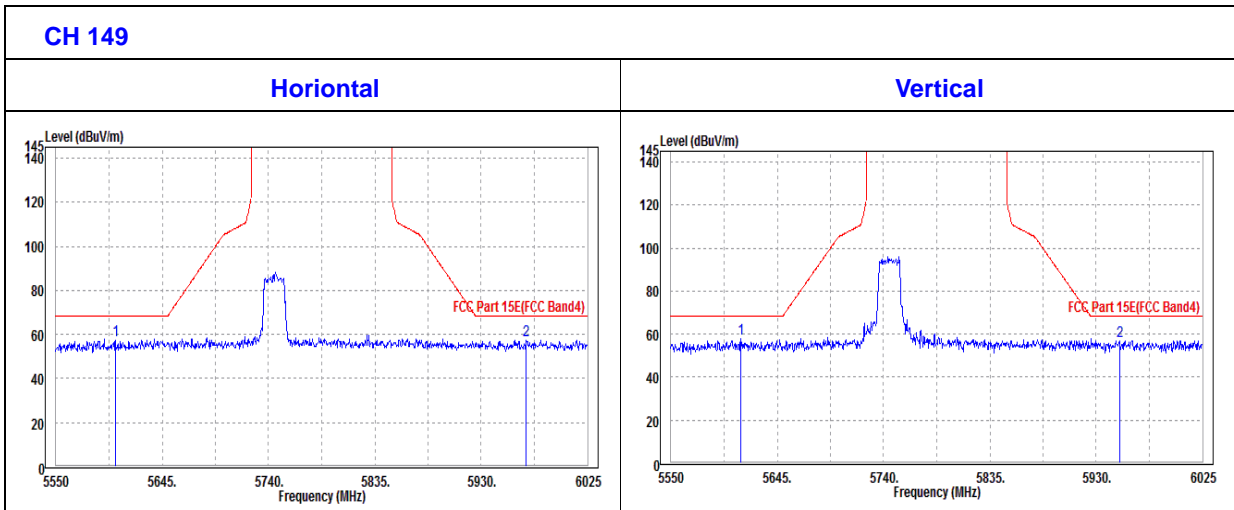



CHANNEL	TX Channel 157	DETECTOR FUNCTION	Peak (PK)
FREQUENCY RANGE	1GHz ~ 40GHz		Average (AV)

ANTENNA POLARITY & TEST DISTANCE: HORIZONTAL AT 3 M										
FREQ. (MHz)	EMISSION LEVEL (dBuV/m)	READ LEVEL (dBuV)	LIMIT (dBuV/m)	MARGIN (dB)	ANTENNA FACTOR (dB /m)	CABLE LOSS (dB)	PREAMP FACTOR (dB)	ANTENNA HEIGHT (cm)	TABLE ANGLE (Degree)	REMARK
5785	83.82	84.74			37.57	7.79	46.28	120	200	Average
5785	95.57	96.49			37.57	7.79	46.28	120	200	Peak
ANTENNA POLARITY & TEST DISTANCE: VERTICAL AT 3 M										
FREQ. (MHz)	EMISSION LEVEL (dBuV/m)	READ LEVEL (dBuV)	LIMIT (dBuV/m)	MARGIN (dB)	ANTENNA FACTOR (dB /m)	CABLE LOSS (dB)	PREAMP FACTOR (dB)	ANTENNA HEIGHT (cm)	TABLE ANGLE (Degree)	REMARK
5785	85.02	85.94			37.57	7.79	46.28	100	180	Average
5785	97.55	98.47			37.57	7.79	46.28	100	180	Peak

REMARKS:

1. Emission Level = Read Level+ Antenna Factor + Cable Loss- Preamp Factor
Margin value = Emission level – Limit value.
2. 5785MHz: Fundamental frequency.



OOBE DATA

802.11n (20MHZ)

ANTENNA POLARITY & TEST DISTANCE: HORIZONTAL AT 3 M										
FREQ. (MHz)	EMISSION LEVEL (dBuV/m)	READ LEVEL (dBuV)	LIMIT (dBuV/m)	MARGIN (dB)	ANTENNA FACTOR (dB /m)	CABLE LOSS (dB)	PREAMP FACTOR (dB)	ANTENNA HEIGHT (cm)	TABLE ANGLE (Degree)	REMARK
5621.25	56.69	57.88	68.3	-11.61	37.47	7.62	46.28	130	175	Peak
5944.73	58.54	59.2	68.3	-9.76	37.67	7.95	46.28	130	175	Peak
ANTENNA POLARITY & TEST DISTANCE: VERTICAL AT 3 M										
FREQ. (MHz)	EMISSION LEVEL (dBuV/m)	READ LEVEL (dBuV)	LIMIT (dBuV/m)	MARGIN (dB)	ANTENNA FACTOR (dB /m)	CABLE LOSS (dB)	PREAMP FACTOR (dB)	ANTENNA HEIGHT (cm)	TABLE ANGLE (Degree)	REMARK
5593.7	57.63	58.85	68.3	-10.67	37.46	7.6	46.28	130	175	Peak
5947.58	58.67	59.32	68.3	-9.63	37.67	7.96	46.28	130	175	Peak

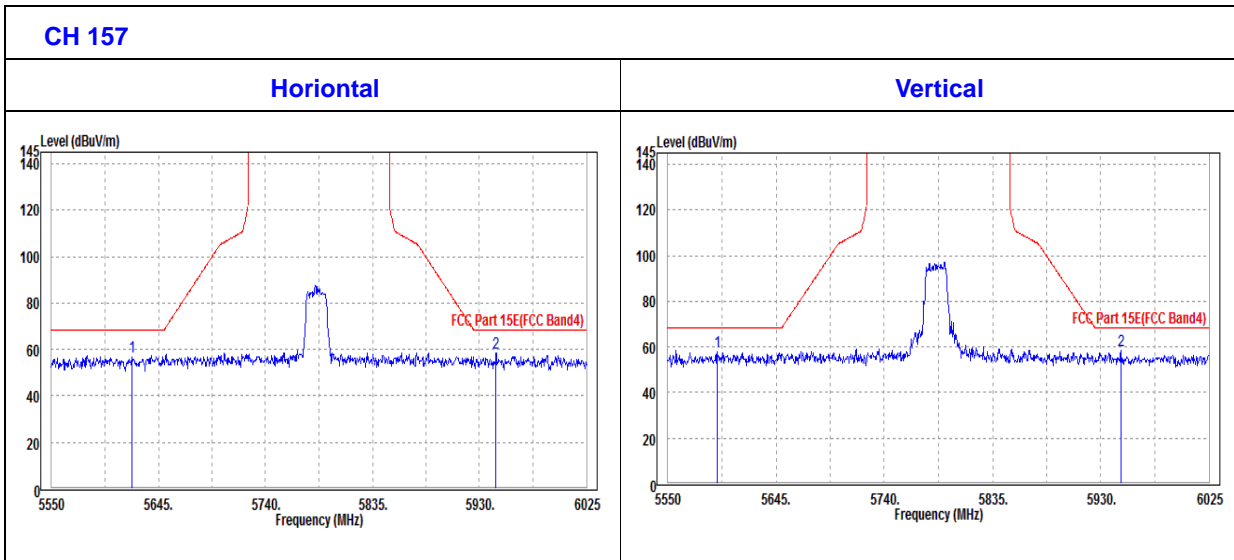



CHANNEL	TX Channel 165	DETECTOR FUNCTION	Peak (PK)
FREQUENCY RANGE	1GHz ~ 40GHz		Average (AV)

ANTENNA POLARITY & TEST DISTANCE: HORIZONTAL AT 3 M										
FREQ. (MHz)	EMISSION LEVEL (dBuV/m)	READ LEVEL (dBuV)	LIMIT (dBuV/m)	MARGIN (dB)	ANTENNA FACTOR (dB /m)	CABLE LOSS (dB)	PREAMP FACTOR (dB)	ANTENNA HEIGHT (cm)	TABLE ANGLE (Degree)	REMARK
5825	91.63	92.48			37.6	7.83	46.28	130	120	Average
5825	94.69	95.54			37.6	7.83	46.28	130	120	Peak
ANTENNA POLARITY & TEST DISTANCE: VERTICAL AT 3 M										
FREQ. (MHz)	EMISSION LEVEL (dBuV/m)	READ LEVEL (dBuV)	LIMIT (dBuV/m)	MARGIN (dB)	ANTENNA FACTOR (dB /m)	CABLE LOSS (dB)	PREAMP FACTOR (dB)	ANTENNA HEIGHT (cm)	TABLE ANGLE (Degree)	REMARK
5825	89.16	90.01			37.6	7.83	46.28	130	180	Average
5825	97.59	98.44			37.6	7.83	46.28	130	180	Peak

REMARKS:

1. Emission Level = Read Level+ Antenna Factor + Cable Loss- Preamp Factor
Margin value = Emission level – Limit value.
2. 5825MHz: Fundamental frequency.



OOBE DATA

802.11n (20MHZ)

ANTENNA POLARITY & TEST DISTANCE: HORIZONTAL AT 3 M										
FREQ. (MHz)	EMISSION LEVEL (dBuV/m)	READ LEVEL (dBuV)	LIMIT (dBuV/m)	MARGIN (dB)	ANTENNA FACTOR (dB /m)	CABLE LOSS (dB)	PREAMP FACTOR (dB)	ANTENNA HEIGHT (cm)	TABLE ANGLE (Degree)	REMARK
5614.6	57.67	58.86	68.3	-10.63	37.47	7.62	46.28	130	175	Peak
5973.23	59.28	59.9	68.3	-9.02	37.68	7.98	46.28	130	175	Peak
ANTENNA POLARITY & TEST DISTANCE: VERTICAL AT 3 M										
FREQ. (MHz)	EMISSION LEVEL (dBuV/m)	READ LEVEL (dBuV)	LIMIT (dBuV/m)	MARGIN (dB)	ANTENNA FACTOR (dB /m)	CABLE LOSS (dB)	PREAMP FACTOR (dB)	ANTENNA HEIGHT (cm)	TABLE ANGLE (Degree)	REMARK
5618.4	57.51	58.7	68.3	-10.79	37.47	7.62	46.28	130	175	Peak
5949.95	57.73	58.38	68.3	-10.57	37.67	7.96	46.28	130	175	Peak

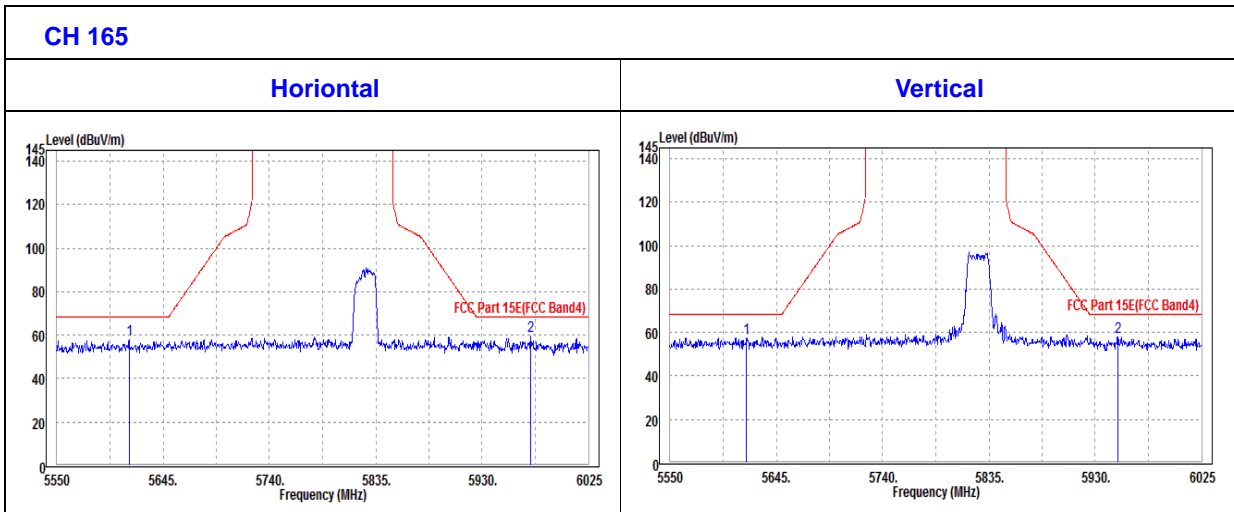



802.11n (40MHz)

CHANNEL	TX Channel 151	DETECTOR FUNCTION	Peak (PK)
FREQUENCY RANGE	1GHz ~ 40GHz		Average (AV)

ANTENNA POLARITY & TEST DISTANCE: HORIZONTAL AT 3 M										
FREQ. (MHz)	EMISSION LEVEL (dBuV/m)	READ LEVEL (dBuV)	LIMIT (dBuV/m)	MARGIN (dB)	ANTENNA FACTOR (dB /m)	CABLE LOSS (dB)	PREAMP FACTOR (dB)	ANTENNA HEIGHT (cm)	TABLE ANGLE (Degree)	REMARK
5755	87.69	91			35.21	7.76	46.28	100	135	Average
5755	96.06	99.37			35.21	7.76	46.28	100	135	Peak
ANTENNA POLARITY & TEST DISTANCE: VERTICAL AT 3 M										
FREQ. (MHz)	EMISSION LEVEL (dBuV/m)	READ LEVEL (dBuV)	LIMIT (dBuV/m)	MARGIN (dB)	ANTENNA FACTOR (dB /m)	CABLE LOSS (dB)	PREAMP FACTOR (dB)	ANTENNA HEIGHT (cm)	TABLE ANGLE (Degree)	REMARK
5755	85.57	88.88			35.21	7.76	46.28	100	30	Average
5755	94.59	97.9			35.21	7.76	46.28	100	30	Peak

REMARKS:

1. Emission Level = Read Level+ Antenna Factor + Cable Loss- Preamp Factor
Margin value = Emission level – Limit value.
2. 5755MHz: Fundamental frequency.



OOBE DATA

802.11n (40MHZ)

ANTENNA POLARITY & TEST DISTANCE: HORIZONTAL AT 3 M										
FREQ. (MHz)	EMISSION LEVEL (dBuV/m)	READ LEVEL (dBuV)	LIMIT (dBuV/m)	MARGIN (dB)	ANTENNA FACTOR (dB /m)	CABLE LOSS (dB)	PREAMP FACTOR (dB)	ANTENNA HEIGHT (cm)	TABLE ANGLE (Degree)	REMARK
5624.1	52.57	56.17	68.3	-15.73	35.05	7.63	46.28	100	125	Peak
5975.13	52.41	55.24	68.3	-15.89	35.47	7.98	46.28	100	125	Peak
ANTENNA POLARITY & TEST DISTANCE: VERTICAL AT 3 M										
FREQ. (MHz)	EMISSION LEVEL (dBuV/m)	READ LEVEL (dBuV)	LIMIT (dBuV/m)	MARGIN (dB)	ANTENNA FACTOR (dB /m)	CABLE LOSS (dB)	PREAMP FACTOR (dB)	ANTENNA HEIGHT (cm)	TABLE ANGLE (Degree)	REMARK
5596.08	52.34	56	68.3	-15.96	35.02	7.6	46.28	100	35	Peak
5972.28	54.09	56.92	68.3	-14.21	35.47	7.98	46.28	100	35	Peak

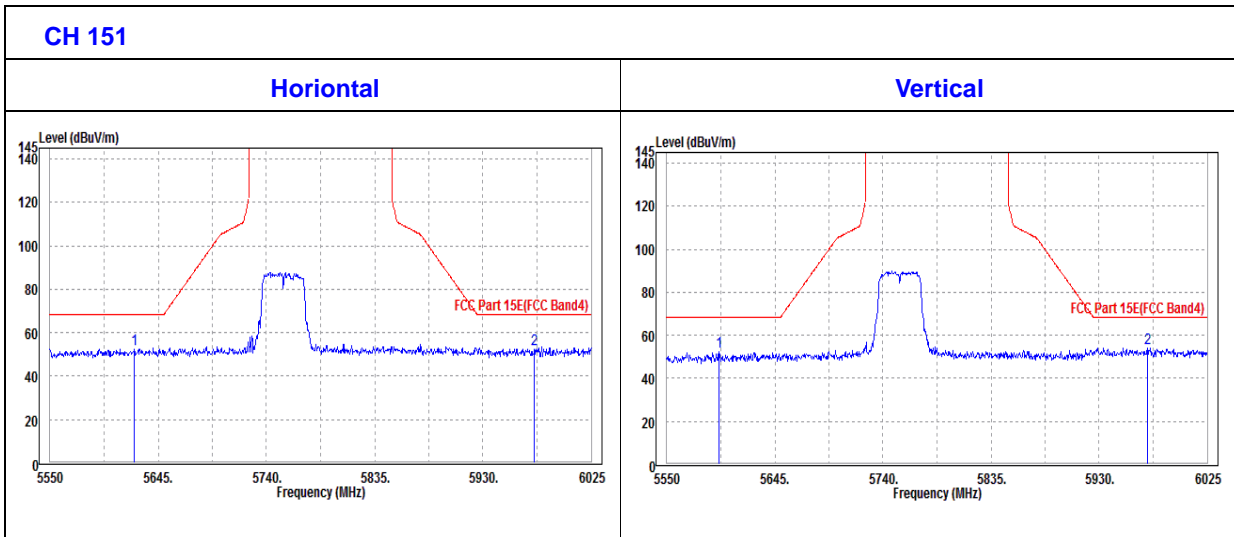



CHANNEL	TX Channel 159	DETECTOR FUNCTION	Peak (PK)
FREQUENCY RANGE	1GHz ~ 40GHz		Average (AV)

ANTENNA POLARITY & TEST DISTANCE: HORIZONTAL AT 3 M										
FREQ. (MHz)	EMISSION LEVEL (dBuV/m)	READ LEVEL (dBuV)	LIMIT (dBuV/m)	MARGIN (dB)	ANTENNA FACTOR (dB /m)	CABLE LOSS (dB)	PREAMP FACTOR (dB)	ANTENNA HEIGHT (cm)	TABLE ANGLE (Degree)	REMARK
5795	88	91.23			35.25	7.8	46.28	100	140	Average
5795	94.35	97.58			35.25	7.8	46.28	100	140	Peak
ANTENNA POLARITY & TEST DISTANCE: VERTICAL AT 3 M										
FREQ. (MHz)	EMISSION LEVEL (dBuV/m)	READ LEVEL (dBuV)	LIMIT (dBuV/m)	MARGIN (dB)	ANTENNA FACTOR (dB /m)	CABLE LOSS (dB)	PREAMP FACTOR (dB)	ANTENNA HEIGHT (cm)	TABLE ANGLE (Degree)	REMARK
5795	86.03	89.26			35.25	7.8	46.28	100	40	Average
5795	96.32	99.55			35.25	7.8	46.28	100	40	Peak

REMARKS:

1. Emission Level = Read Level+ Antenna Factor + Cable Loss- Preamp Factor
Margin value = Emission level – Limit value.
2. 5795MHz: Fundamental frequency.



OOBE DATA

802.11n (40MHZ)

ANTENNA POLARITY & TEST DISTANCE: HORIZONTAL AT 3 M										
FREQ. (MHz)	EMISSION LEVEL (dBuV/m)	READ LEVEL (dBuV)	LIMIT (dBuV/m)	MARGIN (dB)	ANTENNA FACTOR (dB /m)	CABLE LOSS (dB)	PREAMP FACTOR (dB)	ANTENNA HEIGHT (cm)	TABLE ANGLE (Degree)	REMARK
5632.18	48.44	52.03	68.3	-19.86	35.06	7.63	46.28	100	125	Peak
5968.48	51.41	54.25	68.3	-16.89	35.46	7.98	46.28	100	125	Peak
ANTENNA POLARITY & TEST DISTANCE: VERTICAL AT 3 M										
FREQ. (MHz)	EMISSION LEVEL (dBuV/m)	READ LEVEL (dBuV)	LIMIT (dBuV/m)	MARGIN (dB)	ANTENNA FACTOR (dB /m)	CABLE LOSS (dB)	PREAMP FACTOR (dB)	ANTENNA HEIGHT (cm)	TABLE ANGLE (Degree)	REMARK
5606.05	48.7	52.34	68.3	-19.6	35.03	7.61	46.28	100	30	Peak
5949	51.53	54.41	68.3	-16.77	35.44	7.96	46.28	100	30	Peak

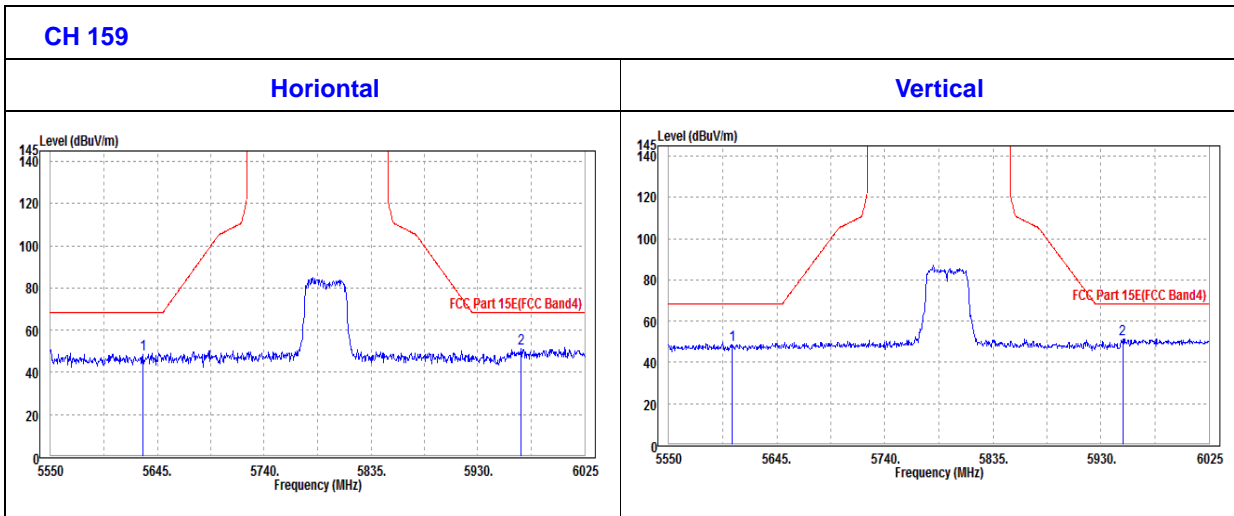



802.11ac (80MHz)

CHANNEL	TX Channel 155	DETECTOR FUNCTION	Peak (PK)
FREQUENCY RANGE	1GHz ~ 40GHz		Average (AV)

ANTENNA POLARITY & TEST DISTANCE: HORIZONTAL AT 3 M										
FREQ. (MHz)	EMISSION LEVEL (dBuV/m)	READ LEVEL (dBuV)	LIMIT (dBuV/m)	MARGIN (dB)	ANTENNA FACTOR (dB /m)	CABLE LOSS (dB)	PREAMP FACTOR (dB)	ANTENNA HEIGHT (cm)	TABLE ANGLE (Degree)	REMARK
5775	89.55	92.82			35.23	7.78	46.28	100	125	Average
5775	93.66	96.93			35.23	7.78	46.28	100	125	Peak
ANTENNA POLARITY & TEST DISTANCE: VERTICAL AT 3 M										
FREQ. (MHz)	EMISSION LEVEL (dBuV/m)	READ LEVEL (dBuV)	LIMIT (dBuV/m)	MARGIN (dB)	ANTENNA FACTOR (dB /m)	CABLE LOSS (dB)	PREAMP FACTOR (dB)	ANTENNA HEIGHT (cm)	TABLE ANGLE (Degree)	REMARK
5775	89.75	93.02			35.23	7.78	46.28	100	35	Average
5775	94.87	98.14			35.23	7.78	46.28	100	35	Peak

REMARKS:

1. Emission Level = Read Level+ Antenna Factor + Cable Loss- Preamp Factor
Margin value = Emission level – Limit value.
2. 5775MHz: Fundamental frequency.



OOBE DATA

802.11ac (80MHZ)

ANTENNA POLARITY & TEST DISTANCE: HORIZONTAL AT 3 M										
FREQ. (MHz)	EMISSION LEVEL (dBuV/m)	READ LEVEL (dBuV)	LIMIT (dBuV/m)	MARGIN (dB)	ANTENNA FACTOR (dB /m)	CABLE LOSS (dB)	PREAMP FACTOR (dB)	ANTENNA HEIGHT (cm)	TABLE ANGLE (Degree)	REMARK
5614.6	59.03	60.22	68.3	-9.27	37.47	7.62	46.28	100	125	Peak
5961.83	58.8	59.43	68.3	-9.5	37.68	7.97	46.28	100	125	Peak
ANTENNA POLARITY & TEST DISTANCE: VERTICAL AT 3 M										
FREQ. (MHz)	EMISSION LEVEL (dBuV/m)	READ LEVEL (dBuV)	LIMIT (dBuV/m)	MARGIN (dB)	ANTENNA FACTOR (dB /m)	CABLE LOSS (dB)	PREAMP FACTOR (dB)	ANTENNA HEIGHT (cm)	TABLE ANGLE (Degree)	REMARK
5608.9	56.64	57.84	68.3	-11.66	37.47	7.61	46.28	100	35	Peak
5948.05	56.55	57.2	68.3	-11.75	37.67	7.96	46.28	100	35	Peak

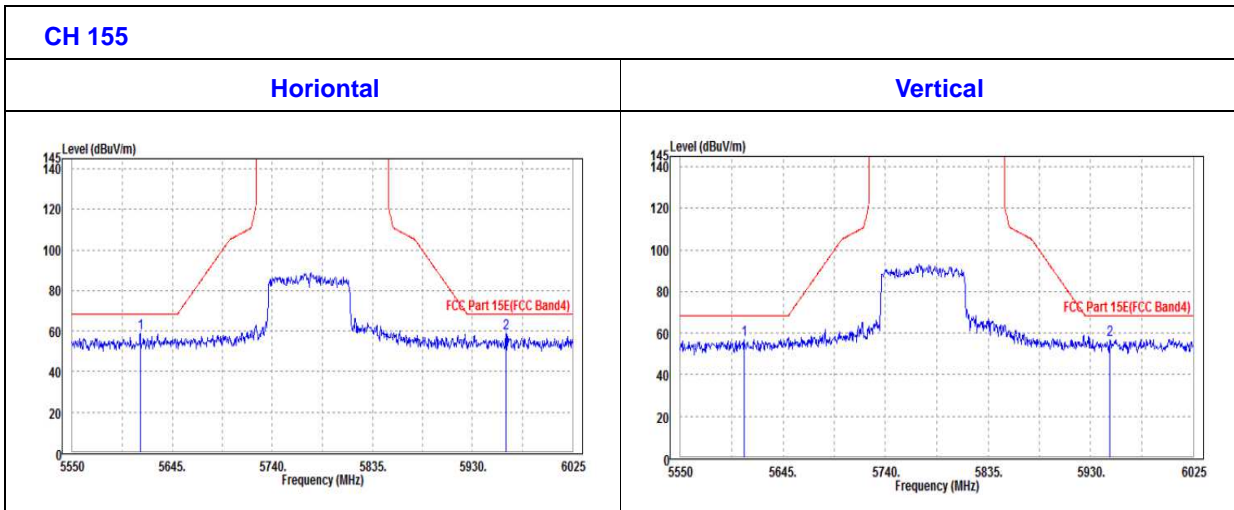



3.2 CONDUCTED EMISSION MEASUREMENT

3.2.1 LIMITS OF CONDUCTED EMISSION MEASUREMENT

FREQUENCY OF EMISSION (MHz)	CONDUCTED LIMIT (dBµV)	
	Quasi-peak	Average
0.15 ~ 0.5	66 to 56	56 to 46
0.5 ~ 5	56	46
5 ~ 30	60	50

- NOTE:**
1. The lower limit shall apply at the transition frequencies.
 2. The limit decreases in line with the logarithm of the frequency in the range of 0.15 to 0.50MHz.
 3. All emanations from a class A/B digital device or system, including any network of conductors and apparatus connected thereto, shall not exceed the level of field strengths specified above.

3.2.2 TEST INSTRUMENTS

Equipment	Manufacturer	Model No.	Serial No.	Last Cal.	Next Cal.
EMI Test Receiver	Rohde&Schwarz	ESR3	101900	Mar. 15,18	Mar. 14,19
EMC32 test software	Rohde&Schwarz	EMC32	NA	NA	NA
LISN network	Rohde&Schwarz	ENV216	101922	Sep. 18,17	Sep. 17,18

- NOTE:**
1. The test was performed in CE shielded room.
 2. The calibration interval of the above test instruments is 12 months. And the calibrations are traceable to CEPREI/CHINA, GRGT/CHINA and NIM/CHINA.

3.2.3 TEST PROCEDURES

- a. The EUT was placed 0.4 meters from the conducting wall of the shielded room with EUT being connected to the power mains through a line impedance stabilization network (LISN). Other support units were connected to the power mains through another LISN. The two LISNs provide 50 ohm/ 50uH of coupling impedance for the measuring instrument.
- b. Both lines of the power mains connected to the EUT were checked for maximum conducted interference.
- c. The frequency range from 150kHz to 30MHz was searched. Emission levels under (Limit - 20dB) was not recorded.

NOTE: All modes of operation were investigated and the worst-case emissions are reported.



3.2.4 DEVIATION FROM TEST STANDARD

No deviation.

3.2.5 TEST SETUP

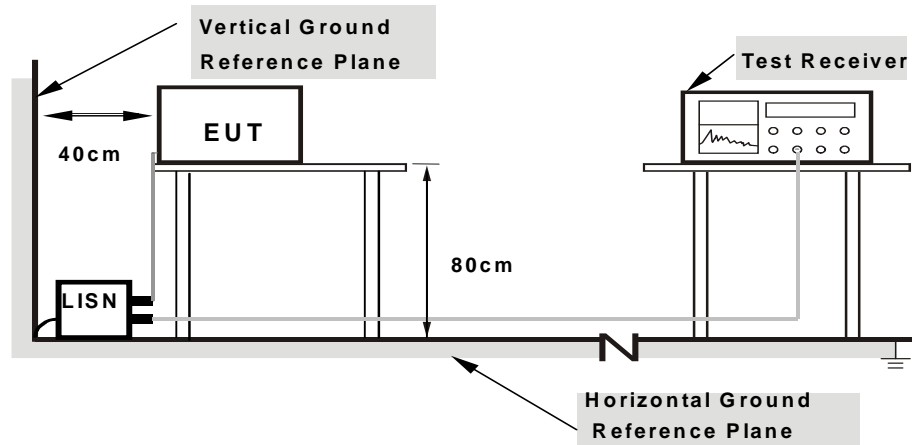

- Note:**
- 1.Support units were connected to second LISN.
 - 2.Both of LISNs (AMN) are 80 cm from EUT and at least 80 from other units and other metal planes

For the actual test configuration, please refer to the attached file (Test Setup Photo).

3.2.6 EUT OPERATING CONDITIONS

Same as 3.1.6.



3.2.7 TEST RESULTS

CONDUCTED WORST-CASE DATA :

Frequency Range	150KHz ~ 30MHz	Detector Function & Resolution Bandwidth	Quasi-Peak (QP) / Average (AV), 9 kHz
Input Power	120Vac, 60Hz	Environmental Conditions	24deg. C, 55RH
Tested By	John Wen	TEST DATE	2018/06/04

Frequency (MHz)	QuasiPeak (dB μ V)	CAverage (dB μ V)	Limit (dB μ V)	Margin (dB)	Line	Filter	Corr. (dB)
0.206000	---	21.87	53.37	-31.50	L1	ON	9.7
0.206000	36.02	---	63.37	-27.35	L1	ON	9.7
1.556000	---	9.00	46.00	-37.00	L1	ON	9.7
1.556000	23.51	---	56.00	-32.49	L1	ON	9.7
2.872000	---	13.27	46.00	-32.73	L1	ON	9.7
2.872000	29.94	---	56.00	-26.06	L1	ON	9.7
4.524000	---	19.40	46.00	-26.60	L1	ON	9.7
4.524000	33.87	---	56.00	-22.13	L1	ON	9.7
9.736000	---	22.35	50.00	-27.65	L1	ON	9.9
9.736000	29.71	---	60.00	-30.29	L1	ON	9.9
15.840000	---	23.05	50.00	-26.95	L1	ON	9.9
15.840000	34.92	---	60.00	-25.08	L1	ON	9.9

- REMARKS:**
1. Q.P. and AV. are abbreviations of quasi-peak and average individually.
 2. "-": The Quasi-peak reading value also meets average limit and measurement with the average detector is unnecessary.
 3. The emission levels of other frequencies were very low against the limit.
 4. Margin value = Emission level - Limit value
 5. Correction factor = Insertion loss + Cable loss
 6. Emission Level = Correction Factor + Reading Value.

Full Spectrum

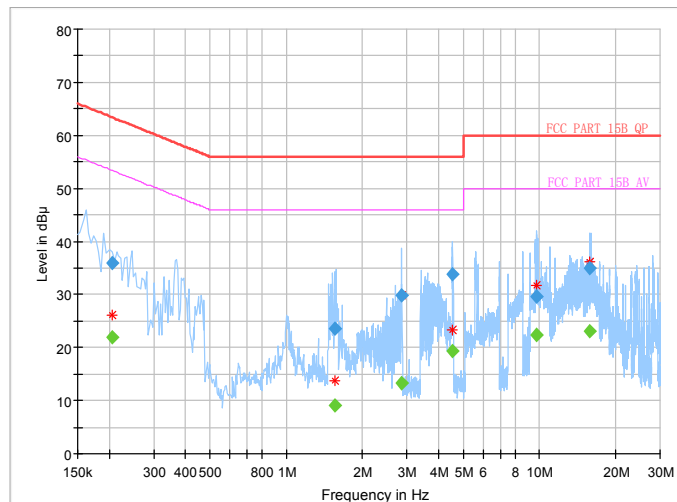



Frequency Range	150KHz ~ 30MHz	Detector Function & Resolution Bandwidth	Quasi-Peak (QP) / Average (AV), 9 kHz
Input Power	120Vac, 60Hz	Environmental Conditions	24deg. C, 55RH
Tested By	John Wen	TEST DATE	2018/06/04

Frequency (MHz)	QuasiPeak (dB μ V)	CAverage (dB μ V)	Limit (dB μ V)	Margin (dB)	Line	Filter	Corr. (dB)
2.000000	---	6.05	46.00	-39.95	N	ON	9.8
2.000000	13.45	---	56.00	-42.55	N	ON	9.8
3.348000	---	13.99	46.00	-32.01	N	ON	9.8
3.348000	27.37	---	56.00	-28.63	N	ON	9.8
3.784000	---	21.43	46.00	-24.57	N	ON	9.8
3.784000	41.34	---	56.00	-14.66	N	ON	9.8
9.484000	---	22.41	50.00	-27.59	N	ON	9.9
9.484000	31.17	---	60.00	-28.83	N	ON	9.9
16.368000	---	26.13	50.00	-23.87	N	ON	10.0
16.368000	33.95	---	60.00	-26.05	N	ON	10.0
17.726000	---	16.55	50.00	-33.45	N	ON	10.0
17.726000	23.10	---	60.00	-36.90	N	ON	10.0

- REMARKS:**
1. Q.P. and AV. are abbreviations of quasi-peak and average individually.
 2. "-": The Quasi-peak reading value also meets average limit and measurement with the average detector is unnecessary.
 3. The emission levels of other frequencies were very low against the limit.
 4. Margin value = Emission level - Limit value
 5. Correction factor = Insertion loss + Cable loss
 6. Emission Level = Correction Factor + Reading Value.

Full Spectrum

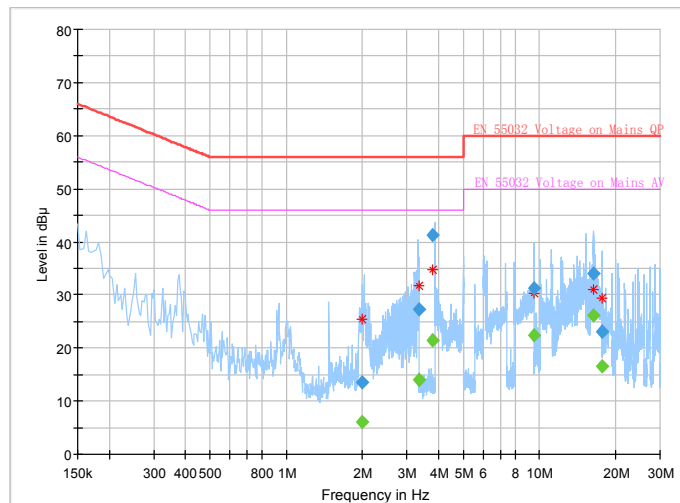



3.3 MAXIMUM CONDUCTED OUTPUT POWER MEASUREMENT

3.3.1 LIMITS OF MAXIMUM CONDUCTED OUTPUT POWER MEASUREMENT

Operation Band	EUT Category		LIMIT
U-NII-1		Outdoor Access Point	1 Watt (30 dBm) (Max. e.i.r.p \leq 125mW(21 dBm) at any elevation angle above 30 degrees as measured from the horizon)
		Fixed point-to-point Access Point	1 Watt (30 dBm)
		Indoor Access Point	1 Watt (30 dBm)
	√	Client devices	250mW (24 dBm)
U-NII-2A	√		250mW (24 dBm) or 11 dBm+10 log B*
U-NII-2C	√		250mW (24 dBm) or 11 dBm+10 log B*
U-NII-3	√		1 Watt (30 dBm)

NOTE: Where B is the 26dB emission bandwidth in MHz.



3.3.2 TEST SETUP

FOR POWER OUTPUT MEASUREMENT

802.11a, 802.11n (20MHz), 802.11n (40MHz) TEST CONFIGURATION

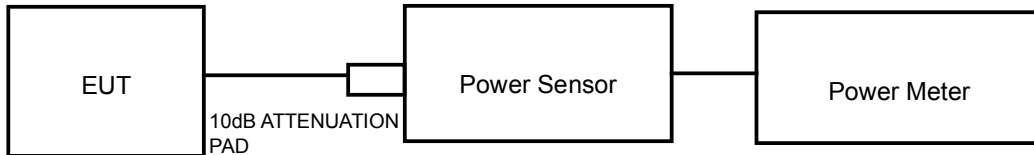

11ac TEST CONFIGURATION

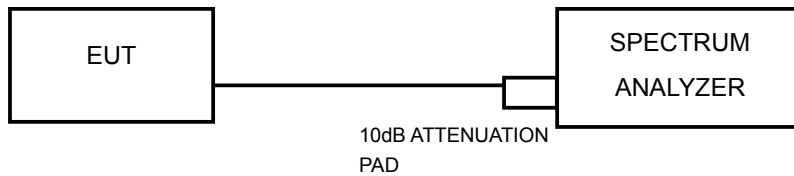

FOR 26dB BANDWIDTH

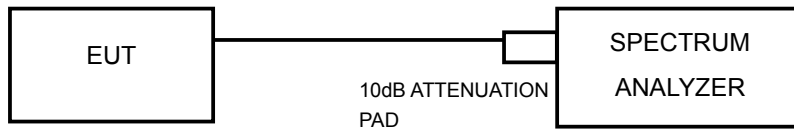

3.3.3 TEST INSTRUMENTS

Equipment	Manufacturer	Model No.	Serial No.	Last Cal.	Next Cal.
Power Meter	ANRITSU	ML2495A	1506002	Mar. 02,18	Mar. 01,19
EXA Signal Analyzer	KEYSIGHT	N9010A-526	MY54510523	Mar. 16,18	Mar. 15,19
EXA Signal Analyzer	KEYSIGHT	N9010A-544	MY54510332	Mar. 16,18	Mar. 15,19
Power Sensor	ANRITSU	MA2411B	1339352	Mar. 16,18	Mar. 15,19

NOTE:

1. The calibration interval of the above test instruments is 12 months and the calibrations are traceable to CEPREI/CHINA, GRGT/CHINA and NIM/CHINA.
2. The test was performed in RF Oven room.



3.3.4 TEST PROCEDURE

FOR POWER MEASUREMENT

For 802.11a, 802.11n (20MHz), 802.11n (40MHz)

Method PM is used to perform output power measurement, trigger and gating function of wide band power meter is enabled to measure max output power of TX on burst. Duty factor is not added to measured value.

For 802.11ac (80MHz)

1. Measure the duty cycle, x , of the transmitter output signal as described in II.B.
2. Set span to encompass the EBW (or, alternatively, the entire 99% occupied bandwidth) of the signal.
3. Set RBW = 1 MHz.
4. Set VBW \geq 3 MHz.
5. Number of points in sweep $\geq 2 \times \text{span} / \text{RBW}$. (This ensures that bin-to-bin spacing is $\leq \text{RBW}/2$, so that narrowband signals are not lost between frequency bins.)
6. Sweep time = auto.
7. Detector = power averaging (rms), if available. Otherwise, use sample detector mode.
8. Do not use sweep triggering. Allow the sweep to “free run.”
9. Trace average at least 100 traces in power averaging (rms) mode; however, the number of traces to be averaged shall be increased above 100 as needed to ensure that the average accurately represents the true average over the on and off periods of the transmitter.
10. Add $10 \log (1/x)$, where x is the duty cycle, to the measured power to compute the average power during the actual transmission times (because the measurement represents an average over both the on and off times of the transmission). For example, add $10 \log (1/0.25) = 6 \text{ dB}$ if the duty cycle is 25%.



FOR 99 PERCENT OCCUPIED BANDWIDTH

The following procedure shall be used for measuring (99 %) power bandwidth:

1. Set center frequency to the nominal EUT channel center frequency.
2. Set span = 1.5 times to 5.0 times the OBW.
3. Set RBW = 1 % to 5 % of the OBW
4. Set VBW $\geq 3 \cdot$ RBW
5. Video averaging is not permitted. Where practical, a sample detection and single sweep mode shall be used. Otherwise, peak detection and max hold mode (until the trace stabilizes) shall be used.
6. Use the 99 % power bandwidth function of the instrument (if available).
7. If the instrument does not have a 99 % power bandwidth function, the trace data points are recovered and directly summed in power units. The recovered amplitude data points, beginning at the lowest frequency, are placed in a running sum until 0.5 % of the total is reached; that frequency is recorded as the lower frequency. The process is repeated until 99.5 % of the total is reached; that frequency is recorded as the upper frequency. The 99% occupied bandwidth is the difference between these two frequencies.

FOR 26dB BANDWIDTH

- 1) Set RBW = approximately 1% of the emission bandwidth.
- 2) Set the VBW > RBW.
- 3) Detector = Peak.
- 4) Trace mode = max hold.
- 5) Measure the maximum width of the emission that is 26 dB down from the peak of the emission. Compare this with the RBW setting of the analyzer. Readjust RBW and repeat measurement as needed until the RBW/EBW ratio is approximately 1%.

FOR 6dB BANDWIDTH

1. Set RBW = 100 kHz.
2. Set the video bandwidth (VBW) ≥ 3 RBW.
3. Detector = Peak.
4. Trace mode = max hold.
5. Sweep = auto couple.
6. Allow the trace to stabilize.
7. Measure the maximum width of the emission that is constrained by the frequencies associated with the two outermost amplitude points (upper and lower frequencies) that are attenuated by 6 dB relative to the maximum level measured in the fundamental emission.



3.3.5 DEVIATION FROM TEST STANDARD

No deviation.

3.3.6 EUT OPERATING CONDITIONS

The software provided by client to enable the EUT under transmission condition continuously at specific channel frequencies individually.



3.3.7 TEST RESULTS

OUTPUT POWER:

802.11a

CHANNEL	CHANNEL FREQUENCY (MHz)	AVERAGE POWER (dBm)	AVERAGE POWER (mW)	POWER LIMIT (dBm)	PASS/FAIL
36	5180	8.86	7.69	24	PASS
40	5200	8.58	7.21	24	PASS
48	5240	8.22	6.64	24	PASS
52	5260	7.40	5.50	24	PASS
60	5300	7.25	5.31	24	PASS
64	5320	7.16	5.20	24	PASS
100	5500	8.53	7.13	24	PASS
116	5580	9.75	9.44	24	PASS
140	5700	9.89	9.75	24	PASS
149	5745	9.47	8.85	30	PASS
157	5785	8.22	6.64	30	PASS
165	5825	8.01	6.32	30	PASS

802.11n (20MHz)

CHANNEL	CHANNEL FREQUENCY (MHz)	AVERAGE POWER (dBm)	AVERAGE POWER (mW)	POWER LIMIT (dBm)	PASS/FAIL
36	5180	8.35	6.84	24	PASS
40	5200	8.37	6.87	24	PASS
48	5240	7.63	5.79	24	PASS
52	5260	7.49	5.61	24	PASS
60	5300	7.37	5.46	24	PASS
64	5320	7.02	5.04	24	PASS
100	5500	7.26	5.32	24	PASS
116	5580	8.77	7.53	24	PASS
140	5700	9.42	8.75	24	PASS
149	5745	8.52	7.11	30	PASS
157	5785	8.04	6.37	30	PASS
165	5825	7.57	5.71	30	PASS



802.11n (40MHz)

CHANNEL	CHANNEL FREQUENCY (MHz)	AVERAGE POWER (dBm)	AVERAGE POWER (mW)	POWER LIMIT (dBm)	PASS/FAIL
38	5190	7.52	5.65	24	PASS
46	5230	7.27	5.33	24	PASS
54	5270	6.29	4.26	24	PASS
62	5310	6.36	4.33	24	PASS
102	5510	7.67	5.85	24	PASS
110	5550	8.23	6.65	24	PASS
134	5670	9.38	8.67	24	PASS
151	5755	8.26	6.70	30	PASS
165	5825	7.33	5.41	30	PASS

802.11ac (80MHz)

CHANNEL	CHANNEL FREQUENCY (MHz)	AVERAGE POWER w/o Duty Factor (dBm)	Duty Factor	AVERAGE POWER with Duty Factor (dBm)	AVERAGE POWER (mW)	POWER LIMIT (dBm)	PASS/FAIL
42	5210	7.45	0.578	8.028	6.35	24	PASS
58	5290	7.27	0.578	7.848	6.09	24	PASS
106	5530	7.41	0.578	7.988	6.29	24	PASS
155	5775	7.56	0.578	8.138	6.51	30	PASS



99% OCCUPIED BANDWIDTH & 26dB BANDWIDTH/6dB BANDWIDTH:

802.11a

CHANNEL	CHANNEL FREQUENCY (MHz)	99% OCCUPIED BANDWIDTH	26dB BANDWIDTH (MHz)	PASS/FAIL
36	5180	16.92	21.54	PASS
40	5200	16.92	21.29	PASS
48	5240	16.92	21.41	PASS
52	5260	16.92	21.39	PASS
60	5300	16.86	21.35	PASS
64	5320	16.38	21.65	PASS
100	5500	16.86	21.56	PASS
116	5580	16.92	21.20	PASS
140	5700	16.98	21.65	PASS
CHANNEL	CHANNEL FREQUENCY (MHz)	99% OCCUPIED BANDWIDTH	6dB BANDWIDTH (MHz)	PASS/FAIL
149	5745	17.10	16.33	PASS
157	5785	17.10	16.33	PASS
165	5825	17.04	16.33	PASS



802.11n (20MHz)

CHANNEL	CHANNEL FREQUENCY (MHz)	99% OCCUPIED BANDWIDTH	26dB BANDWIDTH (MHz)	PASS/FAIL
36	5180	17.94	21.96	PASS
40	5200	17.82	21.49	PASS
48	5240	17.94	21.45	PASS
52	5260	17.88	21.79	PASS
60	5300	18.06	21.46	PASS
64	5320	17.88	21.60	PASS
100	5500	17.94	21.51	PASS
116	5580	18.00	21.41	PASS
140	5700	18.06	21.66	PASS
CHANNEL	CHANNEL FREQUENCY (MHz)	99% OCCUPIED BANDWIDTH	6dB BANDWIDTH (MHz)	PASS/FAIL
149	5745	18.24	17.54	PASS
157	5785	18.24	17.54	PASS
165	5825	18.00	17.31	PASS



802.11n (40MHz)

CHANNEL	CHANNEL FREQUENCY (MHz)	99% OCCUPIED BANDWIDTH	26dB BANDWIDTH (MHz)	PASS/FAIL
38	5190	36.42	40.67	PASS
46	5230	36.42	40.36	PASS
54	5270	36.42	40.62	PASS
62	5310	36.36	41.28	PASS
102	5510	36.54	40.86	PASS
110	5550	36.42	40.81	PASS
134	5670	36.54	40.48	PASS
CHANNEL	CHANNEL FREQUENCY (MHz)	99% OCCUPIED BANDWIDTH	6dB BANDWIDTH (MHz)	PASS/FAIL
151	5755	36.60	35.84	PASS
159	5795	36.54	35.76	PASS

802.11ac (80MHz)

CHANNEL	CHANNEL FREQUENCY (MHz)	99% OCCUPIED BANDWIDTH	26dB BANDWIDTH (MHz)	PASS/FAIL
42	5210	75.48	81.63	PASS
58	5290	75.48	81.53	PASS
106	5530	75.60	81.42	PASS
CHANNEL	CHANNEL FREQUENCY (MHz)	99% OCCUPIED BANDWIDTH	6dB BANDWIDTH (MHz)	PASS/FAIL
155	5775	75.72	75.58	PASS



BUREAU VERITAS

Test Report No.: RF180522W005-3

For U-NII-1:

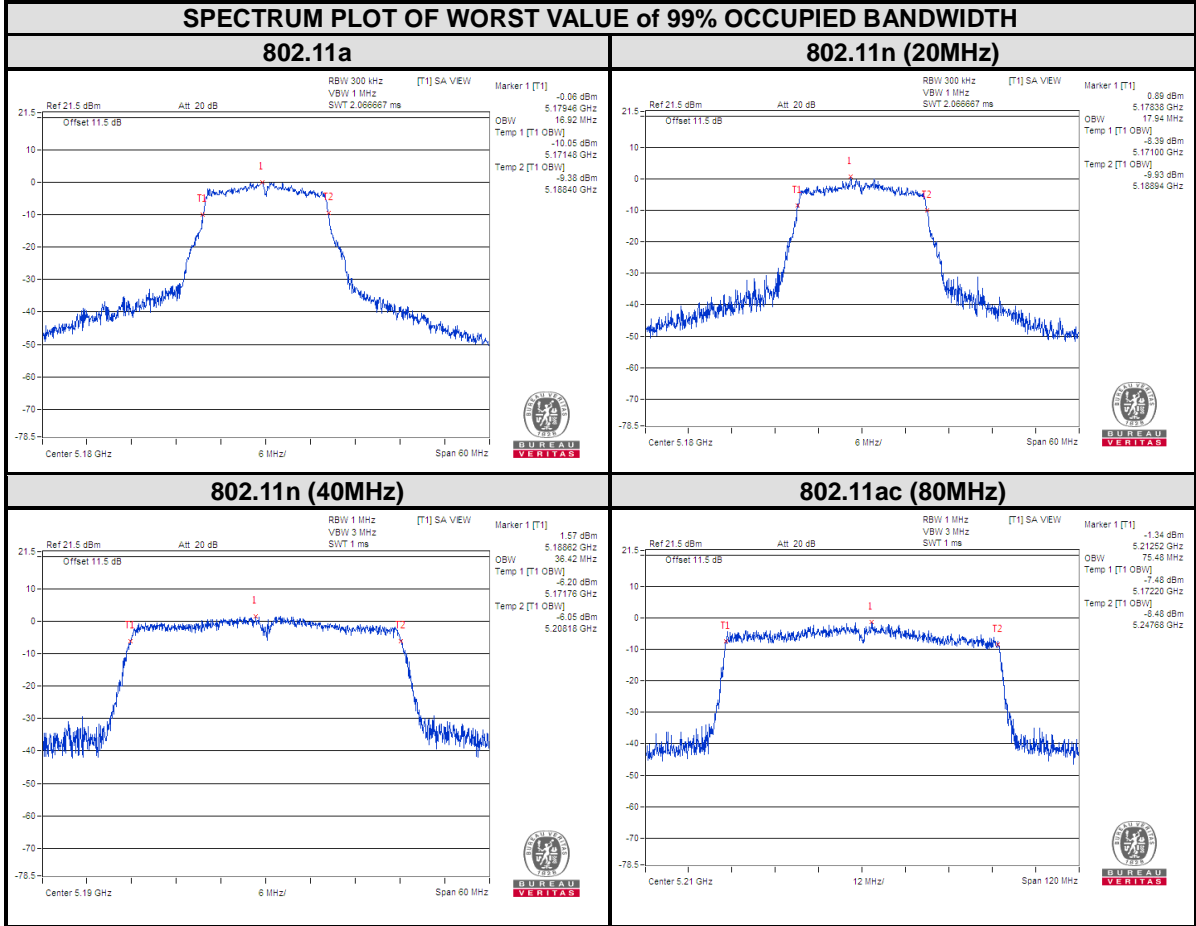

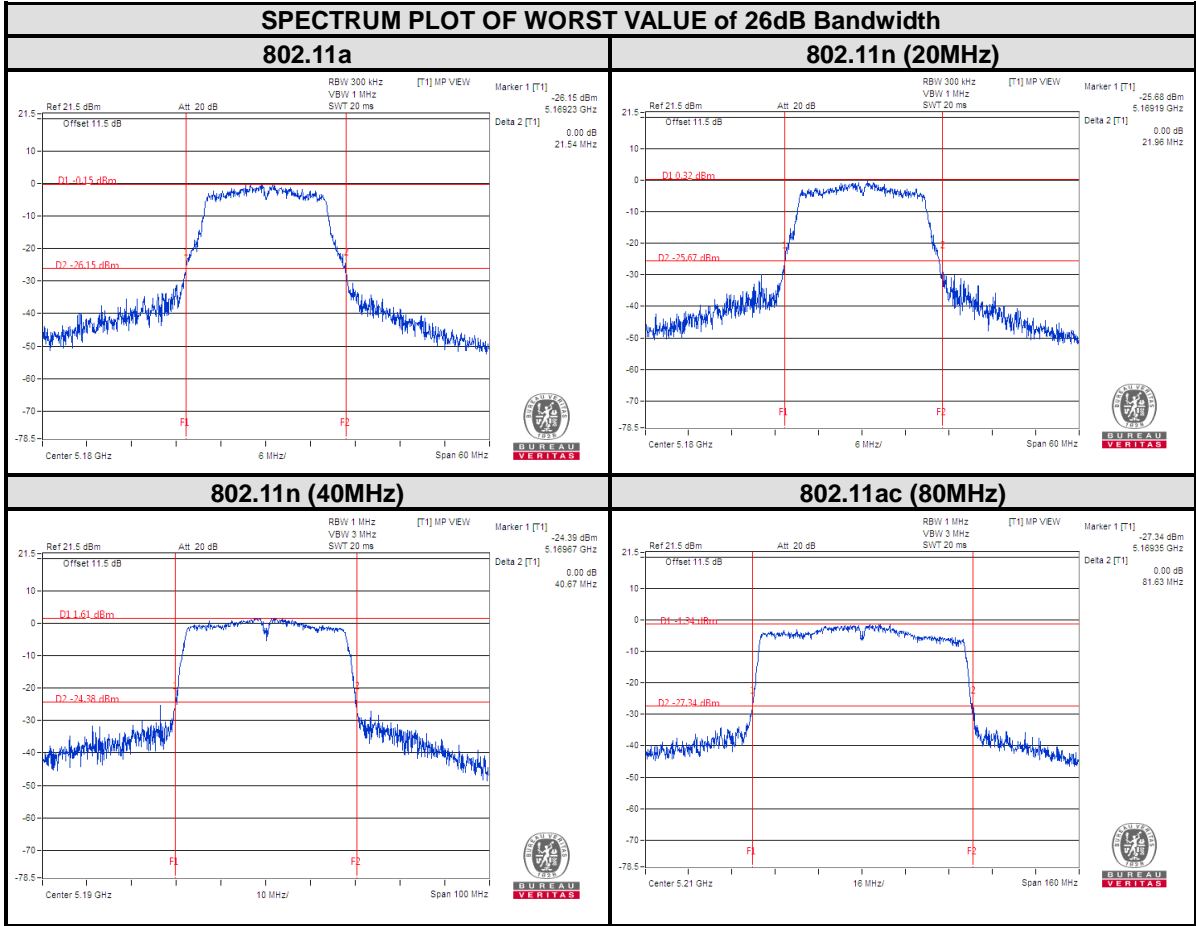



BUREAU VERITAS

Test Report No.: RF180522W005-3

For U-NII-2A:

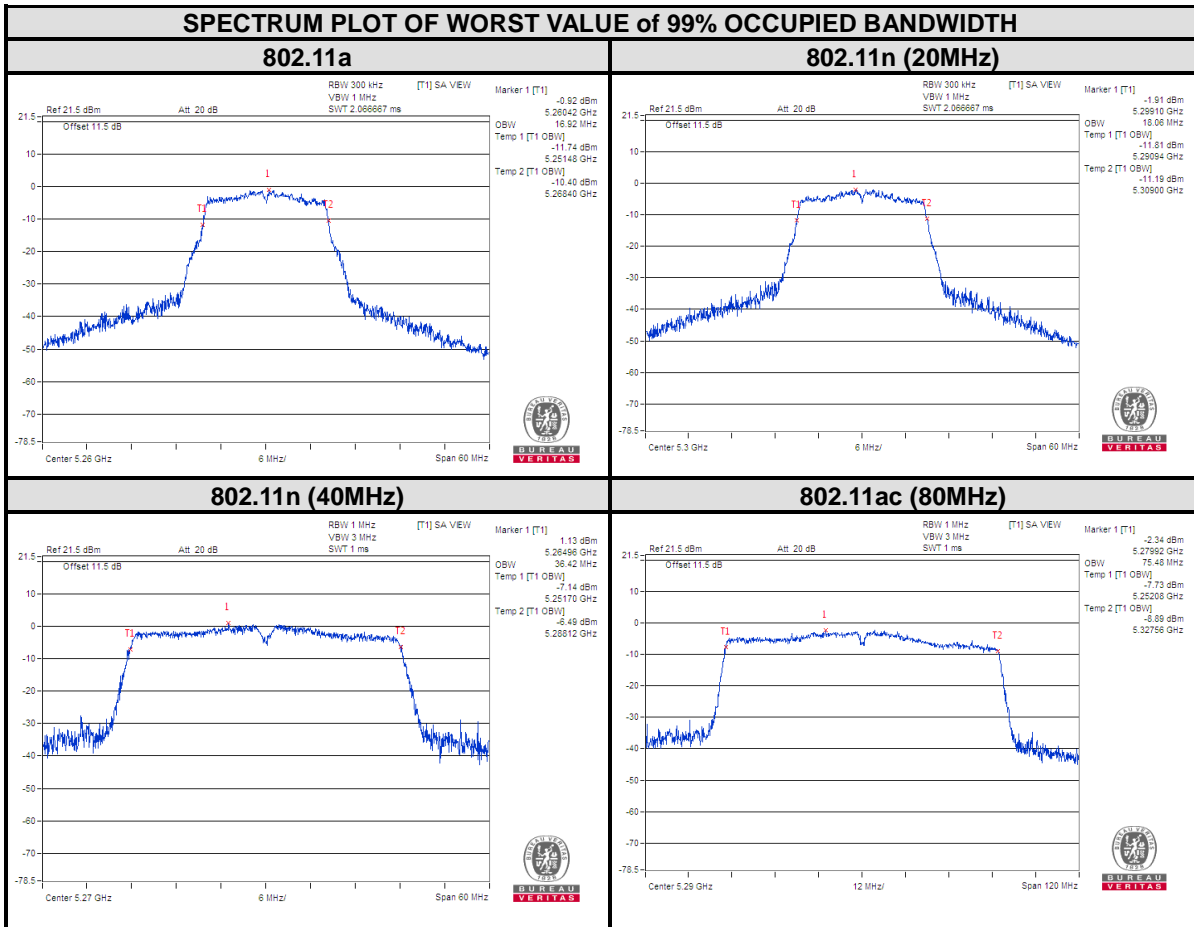



BUREAU VERITAS

Test Report No.: RF180522W005-3

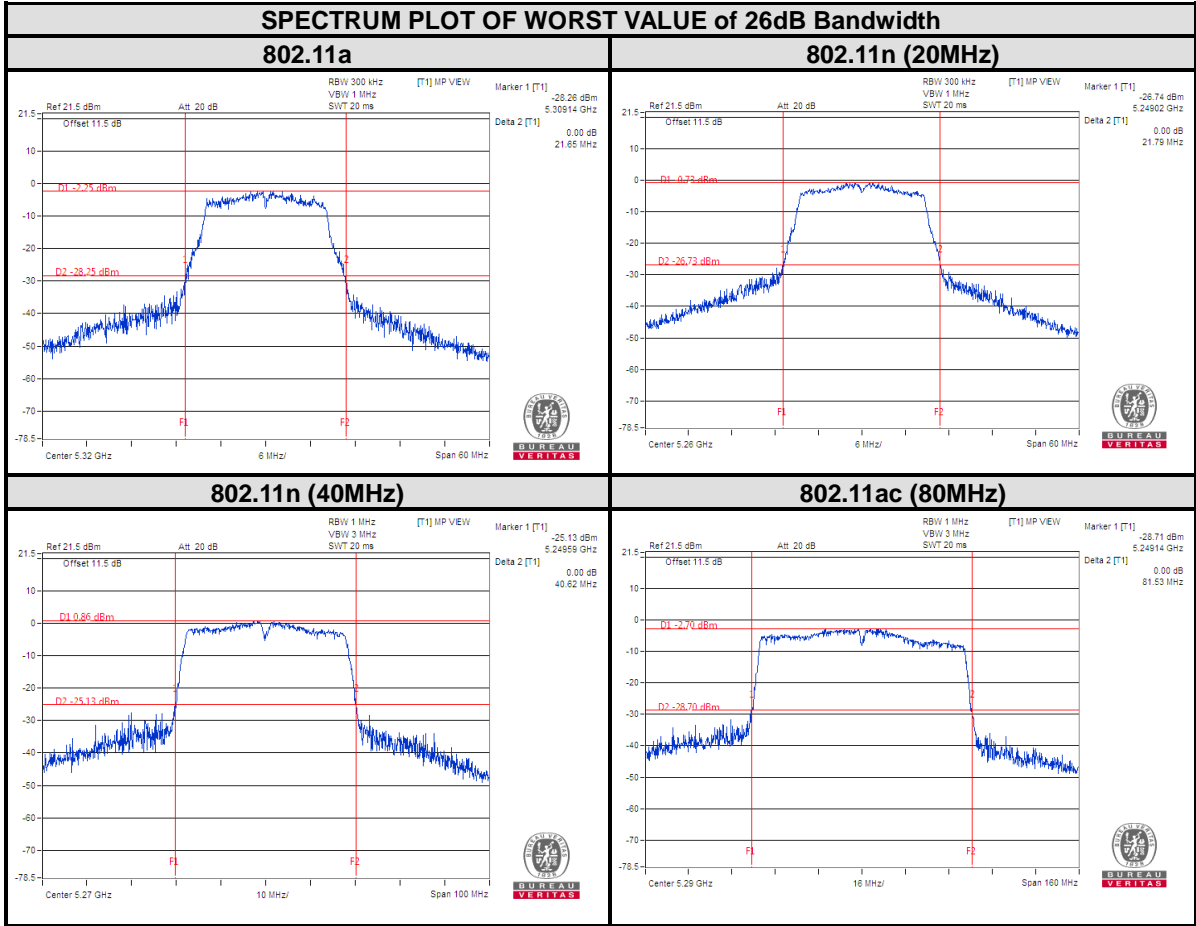



BUREAU VERITAS

Test Report No.: RF180522W005-3

For U-NII-2C:

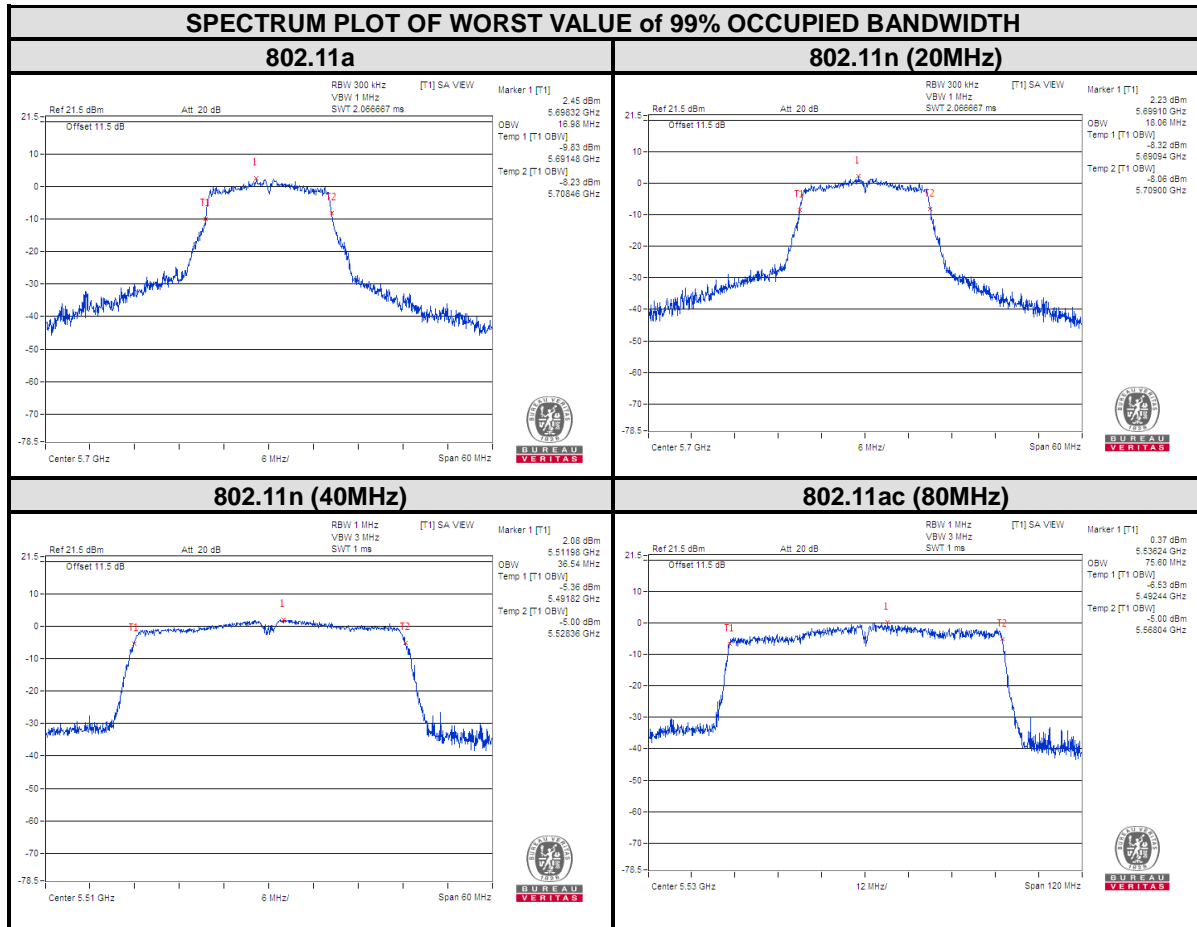



BUREAU VERITAS

Test Report No.: RF180522W005-3

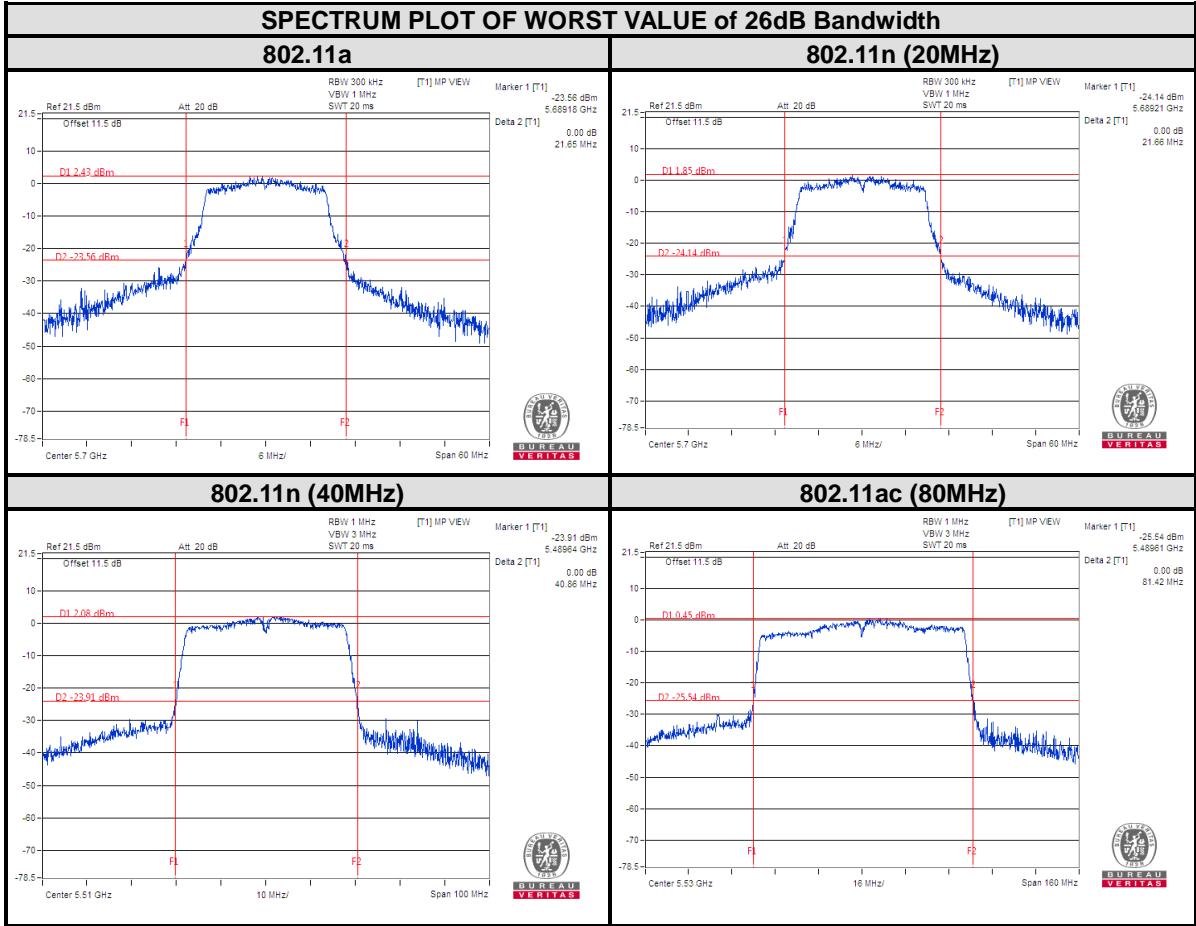



BUREAU VERITAS

Test Report No.: RF180522W005-3

For U-NII-3:

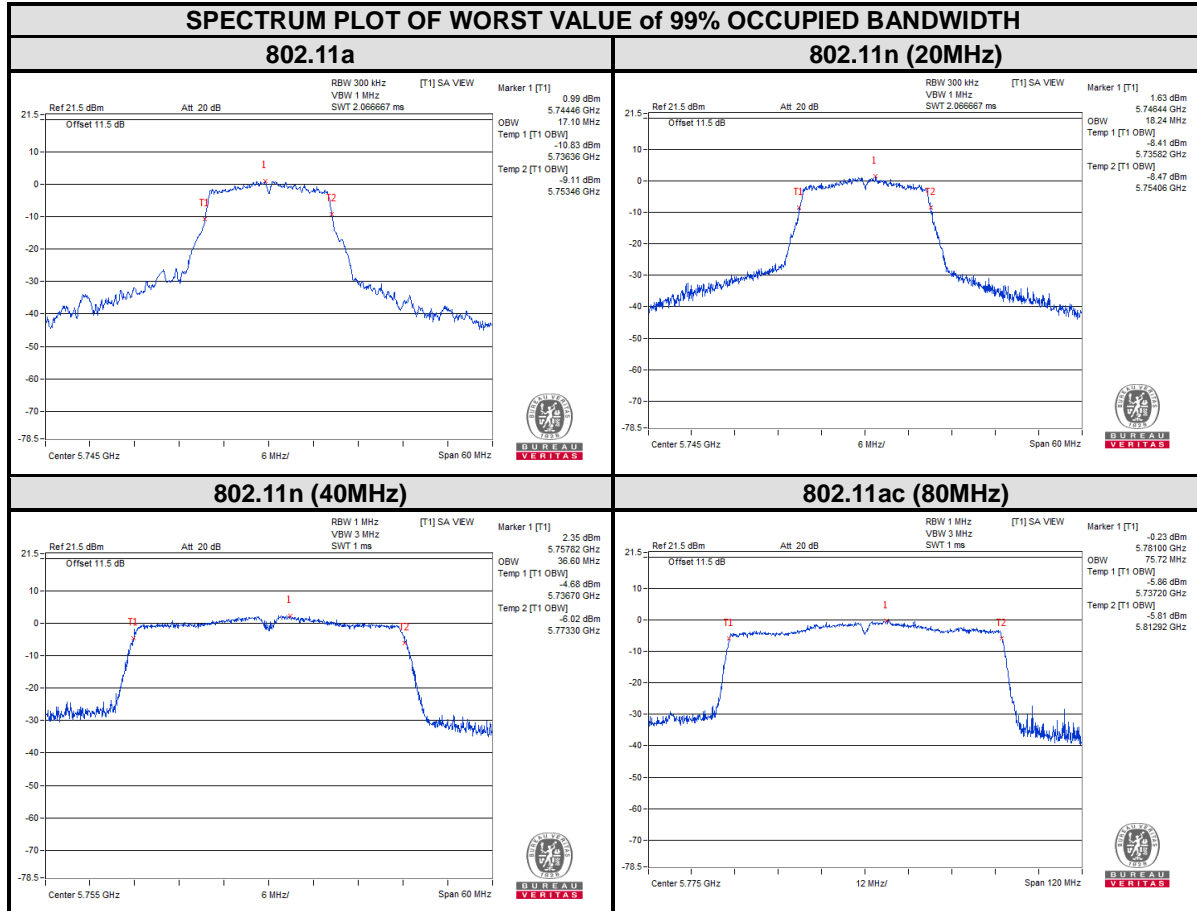



BUREAU VERITAS

Test Report No.: RF180522W005-3

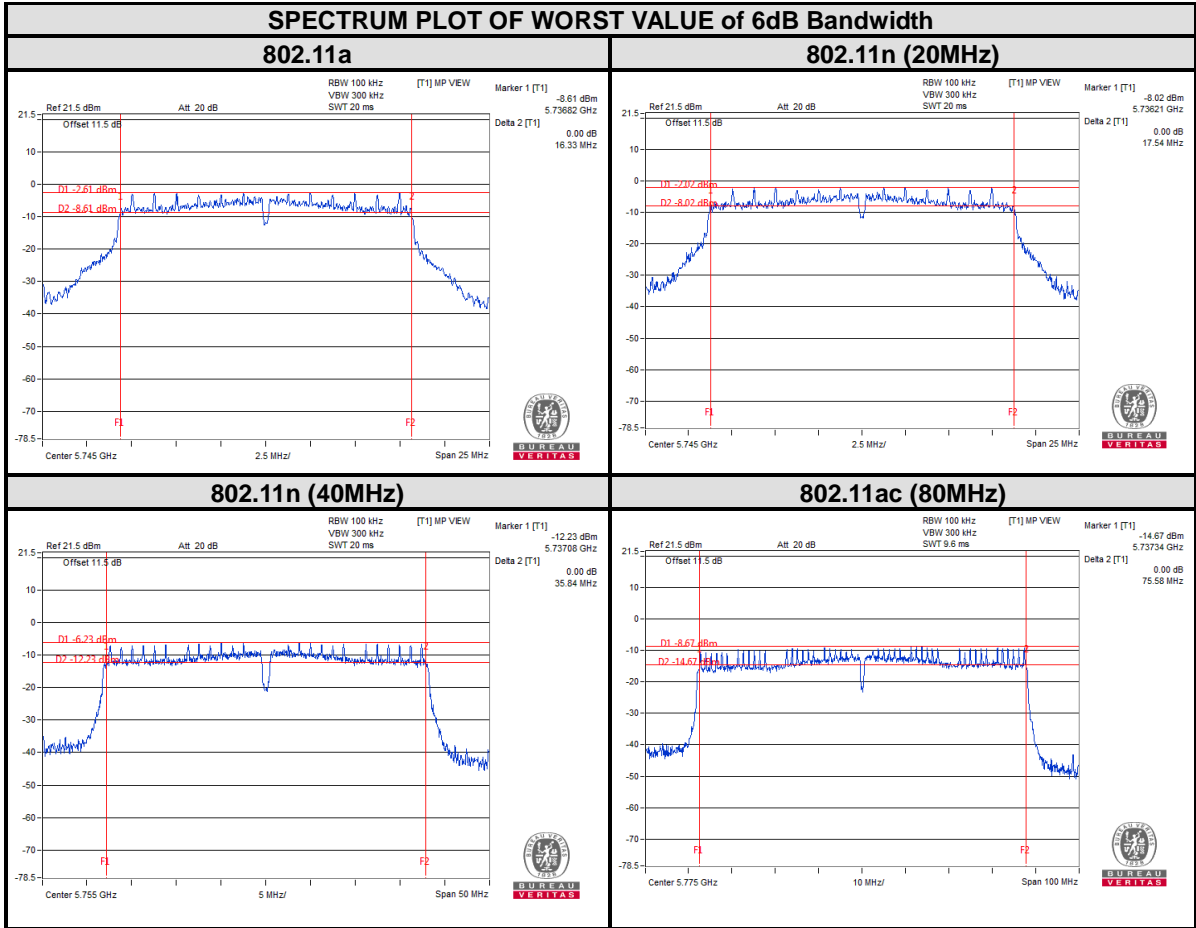



3.4 MAXIMUM POWER SPECTRAL DENSITY MEASUREMENT

3.4.1 LIMITS OF MAXIMUM POWER SPECTRAL DENSITY MEASUREMENT

Operation Band	EUT Category		LIMIT
U-NII-1		Outdoor Access Point	17dBm/ MHz
		Fixed point-to-point Access Point	
		Indoor Access Point	
	√	Client devices	11dBm/ MHz
U-NII-2A	√		11dBm/ MHz
U-NII-2C	√		11dBm/ MHz
U-NII-3	√		30dBm/ 500kHz

3.4.2 TEST SETUP

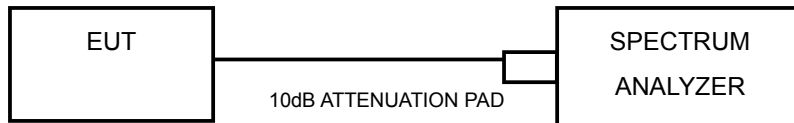

3.4.3 TEST INSTRUMENTS

Refer to section 3.3.3 to get information of above instrument.



3.4.4 TEST PROCEDURES

Using method SA-2

- 1) Set span to encompass the entire emission bandwidth (EBW) of the signal.
- 2) Set RBW = 1 MHz, Set VBW \geq 3 MHz, Detector = RMS
- 3) Set Channel power measure = 1MHz
- 4) Sweep time = auto, trigger set to "free run".
- 5) Trace average at least 100 traces in power averaging mode.
- 6) Add $10 \log (1/x)$, where x is the duty cycle, to the measured power in order to compute the average power during the actual transmission times (because the measurement represents an average over both the on and off times of the transmission).
- 7) Record the max value

3.4.5 DEVIATION FROM TEST STANDARD

No deviation.

3.4.6 EUT OPERATING CONDITIONS

Same as 3.1.6.



3.4.7 TEST RESULTS

For U-NII-1 & U-NII-2A & U-NII-2C :

802.11a

CHANNEL	FREQUENCY (MHz)	PSD w/o Duty Factor (dBm/MHz)	Duty Factor	PSD with Duty Factor (dBm/MHz)	MAXIMUM LIMIT (dBm/MHz)	PASS/FAIL
36	5180	2.62	0.147	2.767	11	PASS
40	5200	2.70	0.147	2.847	11	PASS
48	5240	2.35	0.147	2.497	11	PASS
52	5260	1.82	0.147	1.967	11	PASS
60	5300	1.05	0.147	1.197	11	PASS
64	5320	0.78	0.147	0.927	11	PASS
100	5500	2.86	0.147	3.007	11	PASS
116	5580	5.42	0.147	5.567	11	PASS
140	5700	5.49	0.147	5.637	11	PASS

802.11n (20MHz)

CHANNEL	FREQUENCY (MHz)	PSD w/o Duty Factor (dBm/MHz)	Duty Factor	PSD with Duty Factor (dBm/MHz)	MAXIMUM LIMIT (dBm/MHz)	PASS/FAIL
36	5180	2.61	0.199	2.809	11	PASS
40	5200	2.05	0.199	2.249	11	PASS
48	5240	0.97	0.199	1.169	11	PASS
52	5260	1.06	0.199	1.259	11	PASS
60	5300	0.48	0.199	0.679	11	PASS
64	5320	0.44	0.199	0.639	11	PASS
100	5500	1.40	0.199	1.599	11	PASS
116	5580	4.66	0.199	4.859	11	PASS
140	5700	5.37	0.199	5.569	11	PASS



802.11n (40MHz)

CHANNEL	FREQUENCY (MHz)	PSD w/o Duty Factor (dBm/MHz)	Duty Factor	PSD with Duty Factor (dBm/MHz)	MAXIMUM LIMIT (dBm/MHz)	PASS/FAIL
38	5190	-1.73	0.336	-1.394	11	PASS
46	5230	-2.32	0.336	-1.984	11	PASS
54	5270	-2.77	0.336	-2.434	11	PASS
62	5310	-3.01	0.336	-2.674	11	PASS
102	5510	-1.02	0.336	-0.684	11	PASS
110	5550	0.47	0.336	0.806	11	PASS
134	5670	1.26	0.336	1.596	11	PASS

802.11ac (80MHz)

CHANNEL	FREQUENCY (MHz)	PSD w/o Duty Factor (dBm/MHz)	Duty Factor	PSD with Duty Factor (dBm/MHz)	MAXIMUM LIMIT (dBm/MHz)	PASS/FAIL
42	5210	-4.33	0.578	-3.752	11	PASS
58	5290	-5.91	0.578	-5.332	11	PASS
106	5530	-2.92	0.578	-2.342	11	PASS



For U-NII-3:

802.11a

CHANNEL	FREQUENCY (MHz)	PSD w/o Duty Factor (dBm/MHz)	PSD w/o Duty Factor (dBm/500kHz)	Duty Factor	PSD with Duty Factor (dBm/500kHz)	LIMIT (dBm/500kHz)	PASS /FAIL
149	5745	6.75	8.75	0.147	9.328	30	PASS
157	5785	6.26	8.26	0.147	8.838	30	PASS
165	5825	5.10	7.10	0.147	7.678	30	PASS

802.11n (20MHz)

CHANNEL	FREQUENCY (MHz)	PSD w/o Duty Factor (dBm/MHz)	PSD w/o Duty Factor (dBm/500kHz)	Duty Factor	PSD with Duty Factor (dBm/500kHz)	LIMIT (dBm/500kHz)	PASS /FAIL
149	5745	8.04	10.04	0.199	10.376	30	PASS
157	5785	6.77	8.77	0.199	9.106	30	PASS
165	5825	7.12	9.12	0.199	9.456	30	PASS

802.11n (40MHz)

CHANNEL	FREQUENCY (MHz)	PSD w/o Duty Factor (dBm/MHz)	PSD w/o Duty Factor (dBm/500kHz)	Duty Factor	PSD with Duty Factor (dBm/500kHz)	LIMIT (dBm/500kHz)	PASS /FAIL
151	5755	3.09	5.09	0.336	5.289	30	PASS
159	5795	3.15	5.12	0.336	5.319	30	PASS

802.11ac (80MHz)

CHANNEL	FREQUENCY (MHz)	PSD w/o Duty Factor (dBm/MHz)	PSD w/o Duty Factor (dBm/500kHz)	Duty Factor	PSD with Duty Factor (dBm/500kHz)	LIMIT (dBm/500kHz)	PASS /FAIL
155	5775	0.79	2.79	0.578	3.368	30	PASS



BUREAU
VERITAS

Test Report No.: RF180522W005-3

For 5180~5240MHz

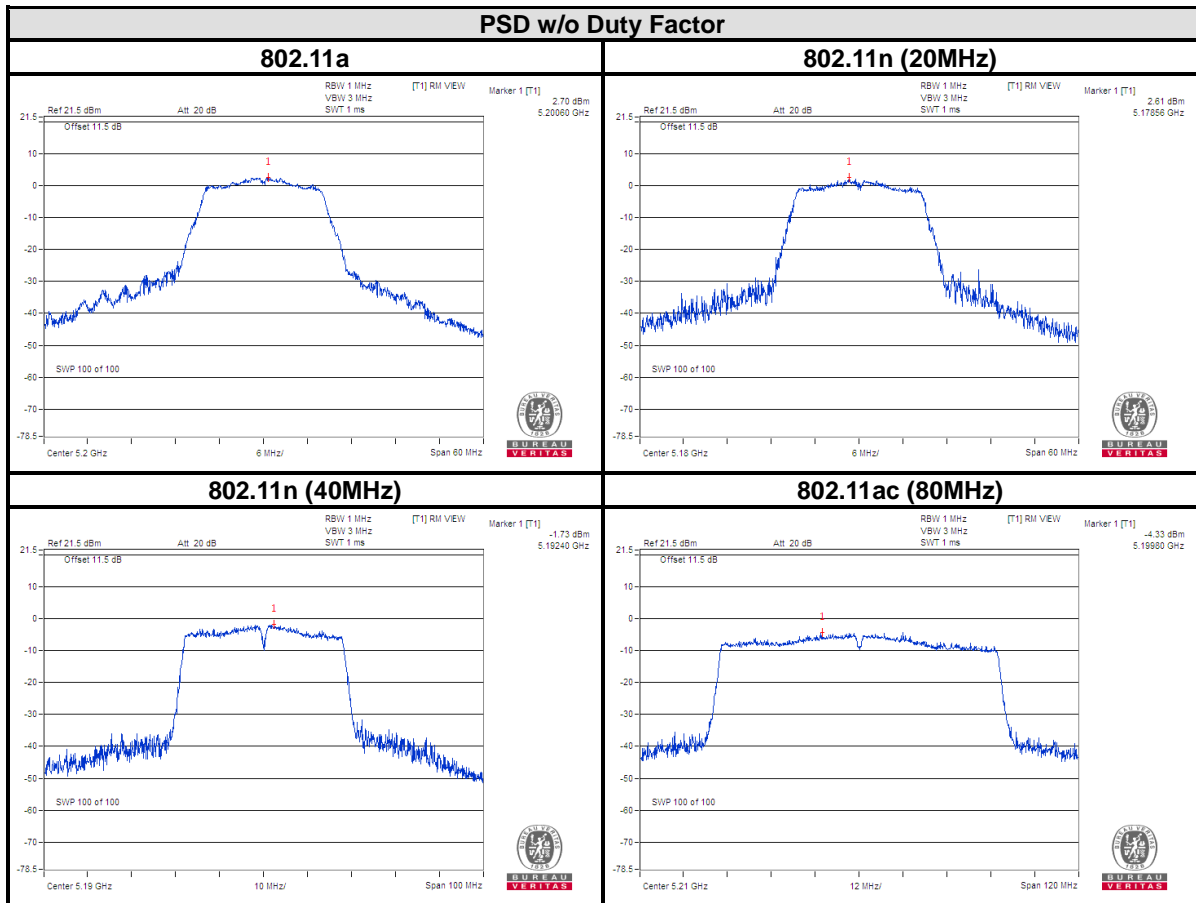



BUREAU VERITAS

Test Report No.: RF180522W005-3

For 5260~5320MHz

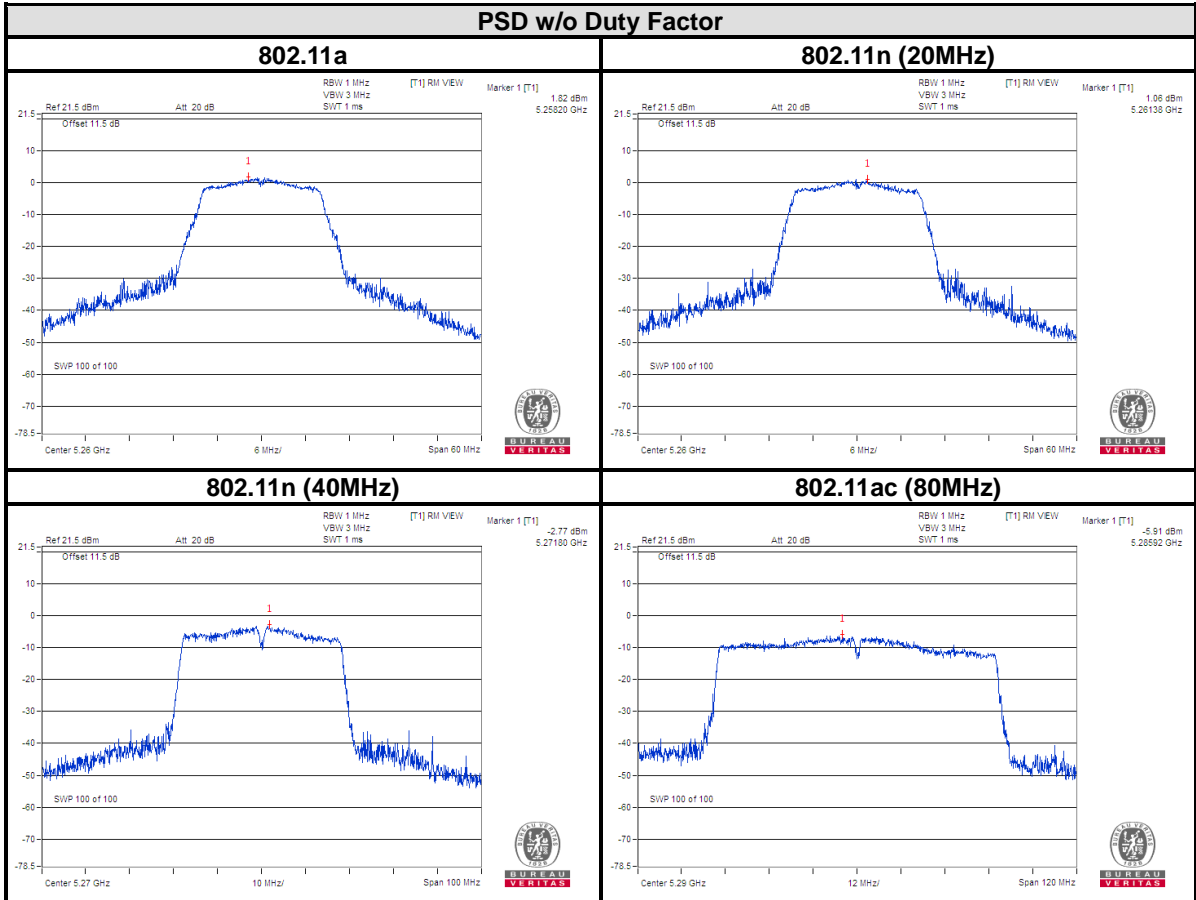



**BUREAU
VERITAS**

Test Report No.: RF180522W005-3

For 5500~5700MHz

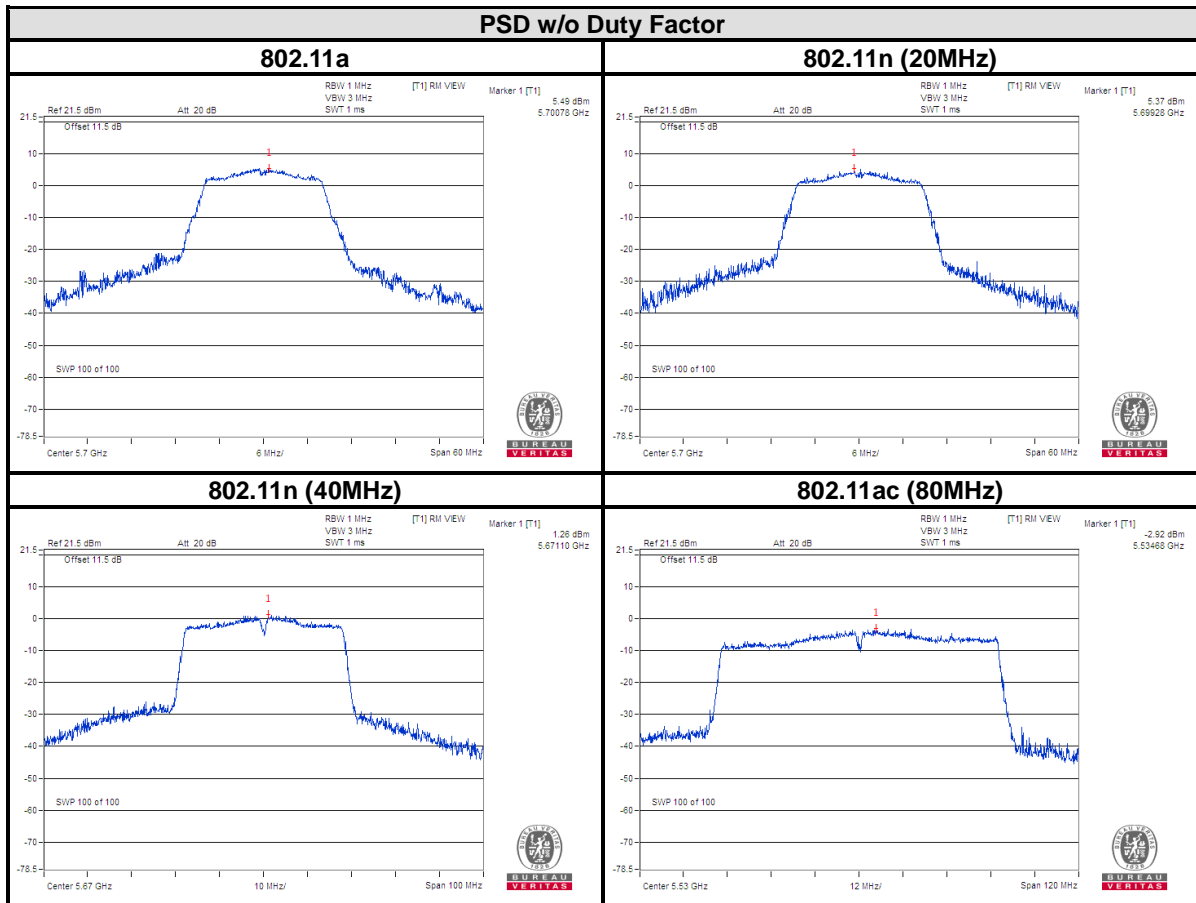



BUREAU VERITAS

Test Report No.: RF180522W005-3

For 5745~5825MHz

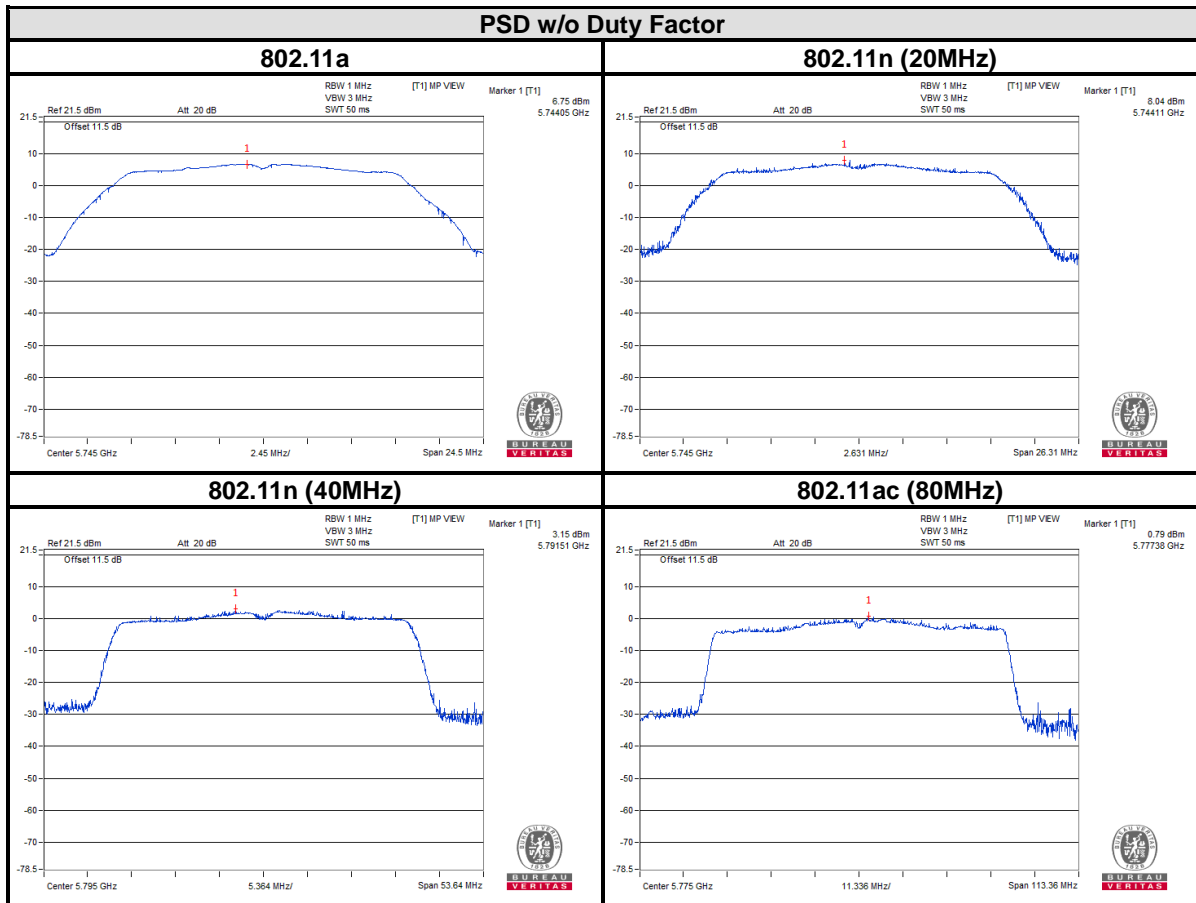



3.5 FREQUENCY STABILITY

3.5.1 LIMITS OF FREQUENCY STABILITY MEASUREMENT

The frequency of the carrier signal shall be maintained within band of operation

3.5.2 TEST SETUP

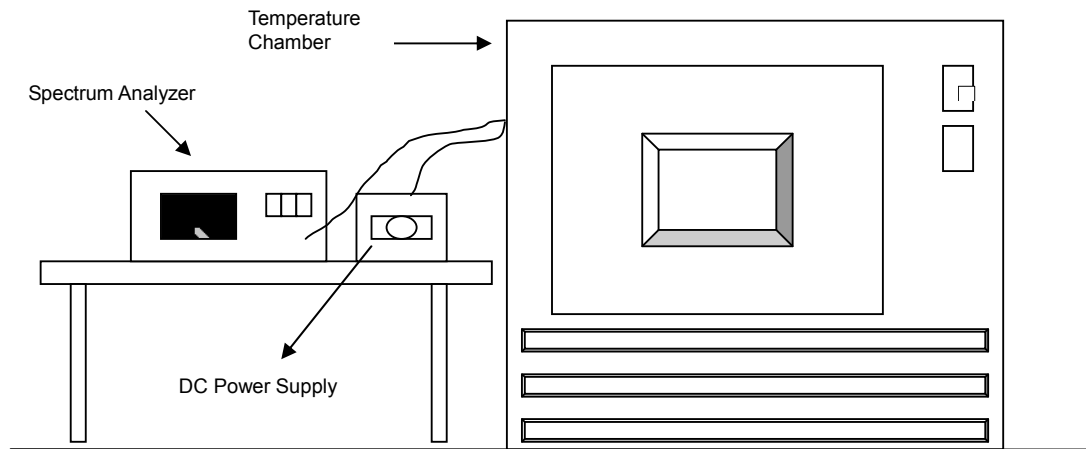

3.5.3 TEST INSTRUMENTS

Refer to section 3.3.3 to get information of above instrument.



3.5.4 TEST PROCEDURE

- a. The EUT was placed inside the environmental test chamber and powered by nominal DC voltage.
- b. Turn the EUT on and couple its output to a spectrum analyzer.
- c. Turn the EUT off and set the chamber to the highest temperature specified.
- d. Allow sufficient time (approximately 30 min) for the temperature of the chamber to stabilize, turn the EUT on and measure the operating frequency after 2, 5, and 10 minutes.
- e. Repeat step 2 and 3 with the temperature chamber set to the lowest temperature.
- f. The test chamber was allowed to stabilize at +20 degree C for a minimum of 30 minutes. The supply voltage was then adjusted on the EUT from 85% to 115% and the frequency record.

3.5.5 DEVIATION FROM TEST STANDARD

No deviation.

3.5.6 EUT OPERATING CONDITION

Set the EUT transmit at un-modulation mode to test frequency stability.



3.5.7 TEST RESULTS

FREQUENCY STABILITY VERSUS TEMP.										
OPERATING FREQUENCY: 5180MHz										
TEMP. (°C)	Power Supply (Vdc)	0 MINUTE		2 MINUTES		5 MINUTES		10 MINUTE		RESULT
		Measured Frequency (MHz)	Frequency Drift (ppm)	Measured Frequency (MHz)	Frequency Drift (ppm)	Measured Frequency (MHz)	Frequency Drift (ppm)	Measured Frequency (MHz)	Frequency Drift (ppm)	
50	120	5180.0209	4.035	5180.0189	3.649	5180.0189	3.649	5180.0237	4.575	PASS
40	120	5180.0074	1.429	5180.0081	1.564	5180.0109	2.104	5180.0153	2.954	PASS
30	120	5180.0051	0.985	5180.0082	1.583	5180.0041	0.792	5180.0085	1.641	PASS
20	120	5180.0222	4.286	5180.021	4.054	5180.019	3.668	5180.0172	3.320	PASS
10	120	5179.9779	-4.266	5179.9742	-4.981	5179.9701	-5.772	5179.9754	-4.749	PASS
0	120	5179.9861	-2.683	5179.9811	-3.649	5179.9867	-2.568	5179.9855	-2.799	PASS
-10	120	5179.9939	-1.178	5179.9902	-1.892	5179.9878	-2.355	5179.9865	-2.606	PASS
-20	120	5180.0005	0.097	5179.9903	-1.873	5179.9995	-0.097	5179.9908	-1.776	PASS
-30	120	5180.0186	3.591	5180.0205	3.958	5180.0203	3.919	5180.0265	5.116	PASS

FREQUENCY STABILITY VERSUS VOLTAGE										
OPERATING FREQUENCY: 5180MHz										
TEMP. (°C)	Power Supply (Vdc)	0 MINUTE		2 MINUTE		5 MINUTE		10 MINUTE		RESULT
		Measured Frequency (MHz)	Frequency Drift (ppm)	Measured Frequency (MHz)	Frequency Drift (ppm)	Measured Frequency (MHz)	Frequency Drift (ppm)	Measured Frequency (MHz)	Frequency Drift (ppm)	
20	138	5180.0236	4.556	5180.0199	3.842	5180.0198	3.822	5180.0191	3.687	PASS
	120	5180.0222	4.286	5180.021	4.054	5180.019	3.668	5180.0172	3.320	PASS
	102	5180.0237	4.575	5180.0211	4.073	5180.0207	3.996	5180.0176	3.398	PASS



FREQUENCY STABILITY VERSUS TEMP.										
OPERATING FREQUENCY: 5825MHz										
TEMP. (°C)	Power Supply (Vdc)	0 MINUTE		2 MINUTES		5 MINUTES		10 MINUTE		RESULT
		Measured Frequency (MHz)	Frequency Drift (ppm)	Measured Frequency (MHz)	Frequency Drift (ppm)	Measured Frequency (MHz)	Frequency Drift (ppm)	Measured Frequency (MHz)	Frequency Drift (ppm)	
50	120	5825.0184	3.159	5825.019	3.262	5825.0175	3.004	5825.0178	3.056	PASS
40	120	5824.983	-2.918	5824.9813	-3.210	5824.9895	-1.803	5824.9888	-1.923	PASS
30	120	5825.0019	0.326	5825.0013	0.223	5824.9997	-0.052	5825.0038	0.652	PASS
20	120	5824.9814	-3.193	5824.9796	-3.502	5824.9736	-4.532	5824.974	-4.464	PASS
10	120	5825.0086	1.476	5825.0006	0.103	5825.0056	0.961	5825.0001	0.017	PASS
0	120	5825.0218	3.742	5825.0265	4.549	5825.0251	4.309	5825.0216	3.708	PASS
-10	120	5825.0116	1.991	5825.0073	1.253	5825.0081	1.391	5825.0102	1.751	PASS
-20	120	5825.0104	1.785	5825.0105	1.803	5825.0115	1.974	5825.0175	3.004	PASS
-30	120	5825.0057	0.979	5825.0108	1.854	5825.0112	1.923	5825.0109	1.871	PASS

FREQUENCY STABILITY VERSUS VOLTAGE										
OPERATING FREQUENCY: 5180MHz										
TEMP. (°C)	Power Supply (Vdc)	0 MINUTE		2 MINUTE		5 MINUTE		10 MINUTE		RESULT
		Measured Frequency (MHz)	Frequency Drift (ppm)	Measured Frequency (MHz)	Frequency Drift (ppm)	Measured Frequency (MHz)	Frequency Drift (ppm)	Measured Frequency (MHz)	Frequency Drift (ppm)	
20	138	5824.9813	-3.210	5824.9795	-3.519	5824.972	-4.807	5824.9752	-4.258	PASS
	120	5824.9814	-3.193	5824.9796	-3.502	5824.9736	-4.532	5824.974	-4.464	PASS
	102	5824.9814	-3.193	5824.978	-3.777	5824.9716	-4.876	5824.9756	-4.189	PASS



**BUREAU
VERITAS**

Test Report No.: RF180522W005-3

4 PHOTOGRAPHS OF THE TEST CONFIGURATION

Please refer to the attached file (Test Setup Photo).



**BUREAU
VERITAS**

Test Report No.: RF180522W005-3

5 APPENDIX A – MODIFICATIONS RECORDERS FOR ENGINEERING CHANGES TO THE EUT BY THE LAB

No modifications were made to the EUT by the lab during the test.

---END---