

DFS TEST REPORT

Applicant: PAX Technology Limited

Address of Applicant: Room 2416, 24/F., Sun Hung Kai Centre, 30 Harbour Road, Wanchai, Hong Kong

Equipment Under Test (EUT)

Product Name: Integrated Smart Terminal

Model No.: E770

Trade mark: PAX

FCC ID: V5PE770

Applicable standards: FCC CFR Title 47 Part 15E (§15.407)

Date of sample receipt: 26 Apr., 2022

Date of Test: 27 Apr., to 23 Jun., 2022

Date of report issued: 24 Jun., 2022

Test Result: PASS*

*In the configuration tested, the EUT complied with the standards specified above.

Tested by:	<u>Janet Wei</u>	Date:	<u>24 Jun., 2022</u>
Reviewed by:	<u>Winnie Zhang</u>	Date:	<u>24 Jun., 2022</u>
Approved by:	<u>Winnie Zhang</u>	Date:	<u>24 Jun., 2022</u>

(Note: A large red circular stamp is overlaid on the signatures. The stamp contains the text: 'TESTING GROUP SHENZHEN', 'JIANYAN TESTING GROUP SHENZHEN', 'Project Engineer', and '检验检测专用章'. The signature 'Winnie Zhang' is written over the stamp.)

This equipment has been shown to be capable of compliance with the applicable technical standards as indicated in the measurement report and was tested in accordance with the measurement procedures specified in above the application standard version. Test results reported herein relate only to the item(s) tested.

This document cannot be reproduced except in full, without prior written approval of the Company. Any unauthorized alteration, forgery or falsification of the content or appearance of this document is unlawful and offenders may be prosecuted to the fullest extent of the law. Unless otherwise stated the results shown in this test report refer only to the sample(s) tested and such sample(s) are retained for 90 days only.

2 Version

Version No.	Date	Description
00	24 Jun., 2022	Original

3 Contents

	Page
1 COVER PAGE.....	1
2 VERSION	2
3 CONTENTS	3
4 TEST SUMMARY	4
5 GENERAL INFORMATION.....	5
5.1 CLIENT INFORMATION	5
5.2 GENERAL DESCRIPTION OF E.U.T.	5
5.3 TEST ENVIRONMENT AND MODE	5
5.4 DESCRIPTION OF SUPPORT UNITS.....	6
5.5 RELATED SUBMITTAL(S) / GRANT (S)	6
5.6 ADDITIONS TO, DEVIATIONS, OR EXCLUSIONS FROM THE METHOD	6
5.7 LABORATORY FACILITY	6
5.8 LABORATORY LOCATION	6
5.9 TEST INSTRUMENTS LIST.....	6
6 DFS TECHNICAL REQUIREMENTS.....	7
6.1 DFS PARAMETERS	7
6.2 DFS TECHNICAL REQUIREMENTS	9
6.3 DFS THRESHOLD LEVEL	9
6.4 TEST SETUP BLOCK.....	9
6.5 EUT CONFIGURATION FOR DFS TEST.....	10
7 TEST RESULT	11
7.1 VERIFICATION OF RADAR TYPE AND LEVEL	11
7.2 CHANNEL MOVE TIME AND CHANNEL CLOSING TRANSMISSION TIME.....	13
8 TEST SETUP PHOTO	15
9 EUT CONSTRUCTIONAL DETAILS	15

4 Test Summary

Test Items	Limit	Result
Channel Availability Check	> 60 seconds	N/A
UNII Detection Bandwidth	> 100% of the UNII 99% transmission power bandwidth	N/A
Statistical Performance Check	Radar type 1,2,3,4 \geq 60% Aggregate Radar type 1~4 and 5 \geq 80% Radar type 6 \geq 70%	N/A
Channel Move Time	< 10 seconds	Pass
Channel Closing Transmission Time	< 20ms + aggregate of 60ms over remaining 10 second period	Pass
Non-Occupancy Period	> 30 minutes	N/A
<p>Remark:</p> <ol style="list-style-type: none"> 1. Pass: means meet the requirements. 2. N/A: means not applicable. 3. The cable insertion loss used by "RF Output Power" and other conduction measurement items is 0.5dB (provided by the customer). 		
Test Method:	ANSI C63.10-2013 KDB 789033 D02 General UNII Test Procedures New Rules v02r01 KDB 905462 D02 UNII DFS Compliance Procedures New Rules v02	

5 General Information

5.1 Client Information

Applicant:	PAX Technology Limited
Address:	Room 2416, 24/F., Sun Hung Kai Centre, 30 Harbour Road, Wanchai, Hong Kong
Manufacturer:	PAX Computer Technology (Shenzhen) Co., Ltd.
Address:	401 and 402, Building 3, Shenzhen Software Park, Nanshan District, Shenzhen City, Guangdong Province, P.R.C

5.2 General Description of E.U.T.

Product Name:	Integrated Smart Terminal
Model No.:	E770
Transmitter frequency range:	5250MHz~5350MHz 5470MHz~5725MHz
Modulation type:	OFDM
WLAN Function:	802.11a/802.11n/802.11ac
Bandwidth:	20MHz/40MHz/80MHz
Antenna Type:	Internal Antenna
Antenna Gain:	1.0 dBi
DFS Operation Type:	<input type="checkbox"/> Master Device <input type="checkbox"/> Slaver Device with Radar detection function <input checked="" type="checkbox"/> Slaver Device without Radar detection function
Power Supply:	Rechargeable Li-ion polymer Battery DC3.7V, 1100mAh
AC Adapter:	Model: G024A090250ZZUD Input: AC100-240V, 50/60Hz, 0.8A max Output: DC 9.0V, 2.5A
Test Sample Condition:	The test samples were provided in good working order with no visible defects.
Remark:	This EUT has two versions, one is the fixed-line version, the other is the wall-mounted version. The only difference between the two versions is their base interface board is different.

5.3 Test environment and mode

Data Load mode:	Keep the EUT in normal transmitting mode by WiFi
Temperature:	20 ~ 25 °C
Humidity:	60% ~ 65%
Atmospheric pressure:	1012 kPa

5.4 Description of Support Units

Manufacturer	Description	Model	Serial Number
LENOVO	Laptop	SL510	2847A65
ASUS	Router	GT-AX11000	LAICHR000121

5.5 Related Submittal(s) / Grant (s)

This is an original grant, no related submittals and grants.

5.6 Additions to, deviations, or exclusions from the method

No

5.7 Laboratory Facility

The test facility is recognized, certified, or accredited by the following organizations:

- FCC - Designation No.: CN1211**
 JianYan Testing Group Shenzhen Co., Ltd. has been accredited as a testing laboratory by FCC(Federal Communications Commission). The test firm Registration No. is 727551.
- ISED – CAB identifier.: CN0021**
 The 3m Semi-anechoic chamber and 10m Semi-anechoic chamber of JianYan Testing Group Shenzhen Co., Ltd. has been Registered by Certification and Engineering Bureau of Industry Canada for radio equipment testing with Registration No.: 10106A-1.
- CNAS - Registration No.: CNAS L15527**
 JianYan Testing Group Shenzhen Co., Ltd. is accredited to ISO/IEC 17025:2017 General Requirements for the Competence of Testing and Calibration laboratories for the competence of testing. The Registration No. is CNAS L15527.
- A2LA - Registration No.: 4346.01**
 This laboratory is accredited in accordance with the recognized International Standard ISO/IEC 17025:2017 General requirements for the competence of testing and calibration laboratories. The test scope can be found as below link: <https://portal.a2la.org/scopepdf/4346-01.pdf>

5.8 Laboratory Location

JianYan Testing Group Shenzhen Co., Ltd.
 Address: No.101, Building 8, Innovation Wisdom Port, No.155 Hongtian Road, Huangpu Community, Xinqiao Street, Bao'an District, Shenzhen, Guangdong, People's Republic of China.
 Tel: +86-755-23118282, Fax: +86-755-23116366
 Email: info-JYTee@lets.com, Website: <http://jyt.lets.com>

5.9 Test Instruments list

Conducted method:					
Test Equipment	Manufacturer	Model No.	Manage No.	Cal. Date (mm-dd-yy)	Cal. Due date (mm-dd-yy)
Spectrum Analyzer	Keysight	N9010B	WXJ004-3	10-27-2021	10-26-2022
Vector Signal Generator	Keysight	N5182B	WXJ006-6	10-27-2021	10-26-2022
Power Detector Box	MWRFTST	MW100-PSB	WXJ007-4	11-19-2021	11-18-2022
Temperature Humidity Chamber	ZHONG ZHI	CZ-A-80D	WXJ032-3	03-19-2021	03-18-2023
PDU	MWRF-test	XY-G10	N/A	N/A	N/A
Test Software	MWRF-tes	MTS 8310	Version: 2.0.0.0		

6 DFS Technical Requirements

6.1 DFS Parameters

Table D.1: Applicability of DFS Requirements Prior to Use of a Channel			
Requirement	Operational Mode		
	Master	Client Without Radar Detection	Client With Radar Detection
Non-Occupancy period	Yes	Not required	Yes
DFS Detection Threshold	Yes	Not required	Yes
Channel Availability Check Time	Yes	Not required	Not required
U-NII Detection Bandwidth	Yes	Not required	Yes

Table D.2: Applicability of DFS requirements during normal operation		
Requirement	Operational Mode	
	Master	Client Without Radar Detection
DFS Detection Threshold	Yes	Not required
Channel Closing Transmission Time	Yes	Yes
Channel Move Time	Yes	Yes
U-NII Detection Bandwidth	Yes	Not required

Additional requirements for devices with multiple bandwidth modes	Operational Mode	
	Master Device or Client with Radar Detection	Client Without Radar Detection
U-NII Detection Bandwidth and Statistical Performance Check	All BW modes must be tested	Not required
Channel Move Time and Channel Closing Transmission Time	Test using widest BW mode available	Test using the widest BW mode available for the link
All other tests	Any single BW mode	Not required

Note: Frequencies selected for statistical performance check (Section 7.8.4) should include several frequencies within the radar detection bandwidth and frequencies near the edge of the radar detection bandwidth. For 802.11 devices it is suggested to select frequencies in each of the bonded 20 MHz channels and the channel center frequency.

Table D.3: DFS Detection Thresholds	
Maximum Transmit Power	Value (See Notes 1,2, and 3)
EIRP \geq 200 mW	-64 dBm
EIRP < 200 mW and power spectral density < 10 dBm/MHz	-62 dBm
EIRP < 200 mW that do not meet the power spectral density requirement	-64 dBm

Note 1: This is the level at the input of the receiver assuming a 0 dBi receive antenna.
 Note 2: Throughout these test procedures an additional 1 dB has been added to the amplitude of the test transmission waveforms to account for variations in measurement equipment. This will ensure that the test signal is at or above the detection threshold level to trigger a DFS response.
 Note 3: EIRP is based on the highest antenna gain. For MIMO devices refer to KDB Publication 662911 D01.

Table D.4: DFS requirement values	
Parameter	Value
Non-occupancy period	Minimum 30 minutes
Channel Availability Check Time	60 seconds
Channel Move Time	10 seconds (See Note 1)
Channel Closing Transmission Time	200 ms + an aggregate of 60ms over remaining 10 second period (See Notes 1 and 2)
U-NII Detection Bandwidth	Minimum 100% of the UNII 99% transmission power bandwidth (See Note 3)

Note 1: Channel Move Time and the Channel Closing Transmission Time should be performed with Radar Type 0. The measurement timing begins at the end of the Radar Type 0 burst.

Note 2: The Channel Closing Transmission Time is comprised of 200 milliseconds starting at the beginning of the Channel Move Time plus any additional intermittent control signals required to facilitate a Channel move (an aggregate of 60 milliseconds) during the remainder of the 10 second period. The aggregate duration of control signals will not count quiet periods in between transmissions.

Note 3: During the U-NII Detection Bandwidth detection test, radar type 0 should be used. For each frequency step, the minimum percentage of detection is 90 percent. Measurements are performed with no data traffic.

Table D.5: Short Pulse Radar Test Waveforms					
Radar Type	Pulse Width (µsec)	PRI (µsec)	Number of Pulses	Minimum Percentage of Successful Detection	Minimum Number of Trials
0	1	1428	18	See Note 1	See Note 1
1	1	Test A Test B	Roundup $\left\{ \begin{matrix} \left(\frac{1}{360} \right) \cdot \\ \left(\frac{19 \cdot 10^6}{PRI_{\mu sec}} \right) \end{matrix} \right\}$	60%	30
2	1-5	150-230	23-29	60%	30
3	6-10	200-500	16-18	60%	30
4	11-20	200-500	12-16	60%	30
Aggregate (Radar Types 1-4)				80%	120

Note 1: Short Pulse Radar Type 0 should be used for the detection bandwidth test, channel move time, and channel closing time tests.

Table D.6: Long Pulse Radar Test Waveform							
Radar Type	Pulse Width (µsec)	Chirp Width (MHz)	PRI (µsec)	Number of Pulses per Burst	Number of Bursts	Minimum Percentage of Successful Detection	Minimum Number of Trials
5	50-100	5-20	1000-2000	1-3	8-20	80%	30

Long Pulse Radar Test Signal Wave form 12 second transmission

Table D.7: Frequency Hopping Radar Test Waveform							
Radar Type	Pulse Width (µsec)	PRI (µsec)	Pulses per Hop	Hopping Rate (kHz)	Hopping Sequence Length (msec)	Minimum Percentage of Successful Detection	Minimum Number of Trials
6	1	333	0	0.333	300	70%	30

6.2 DFS Technical Requirements

Requirement	DFS Operational mode		
	<input type="checkbox"/> Master	<input checked="" type="checkbox"/> Slave without Radar Detection	<input type="checkbox"/> Slave with Radar Detection
Channel Availability Check	√	Not Required	Not Required
UNII Detection Bandwidth	√	Not Required	√
Statistical Performance Check	√	Not Required	√
Channel Move Time	√	√	√
Channel Closing Transmission Time	√	√	√
Non-Occupancy Period	√	Not Required	√

6.3 DFS Threshold Level

DFS Threshold Level	
5250MHz ~ 5350MHz	-62 dBm @ antenna connector
5470MHz ~ 5725MHz	-62 dBm @ antenna connector

Note: The worst case level was selected to perform the test.

6.4 Test Setup Block

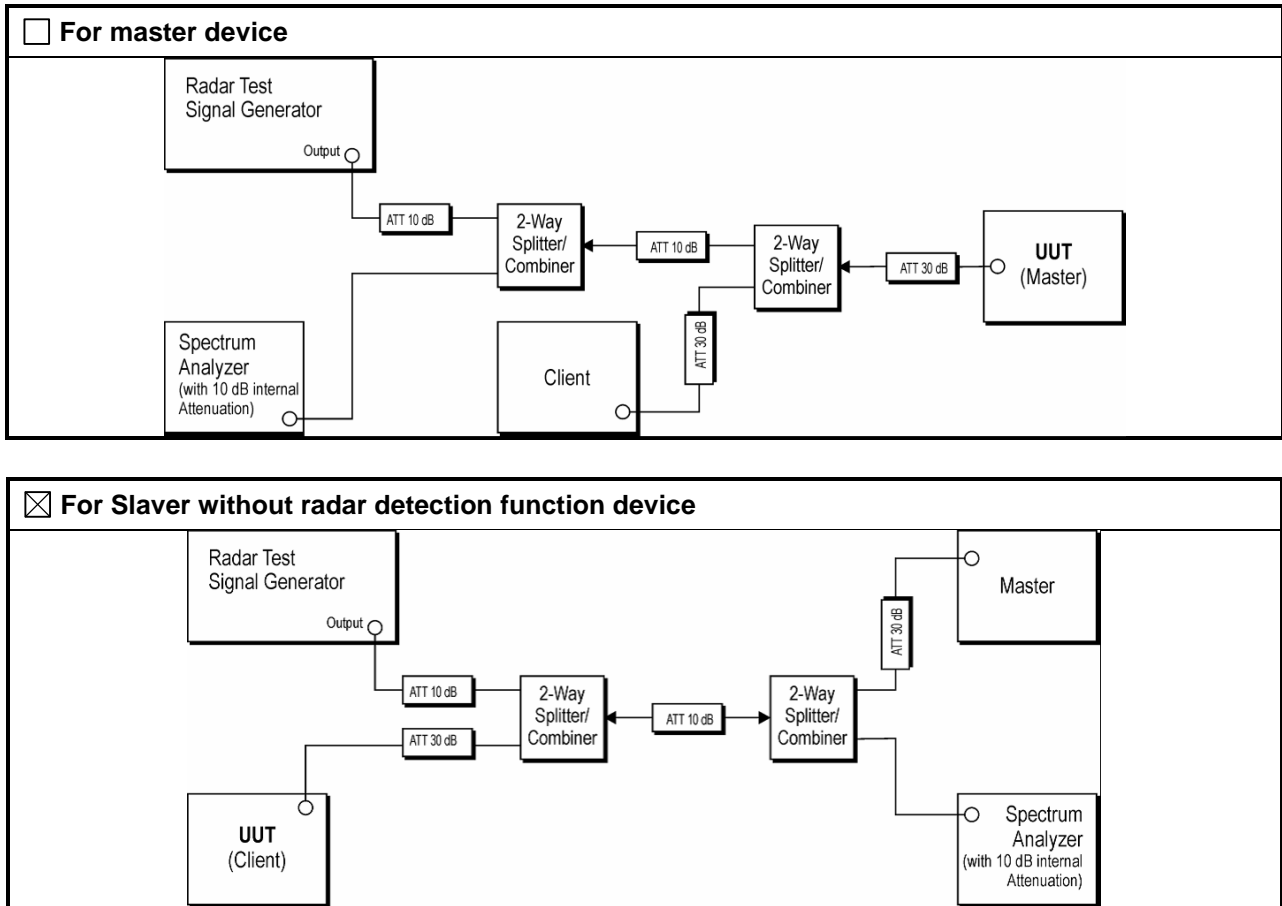

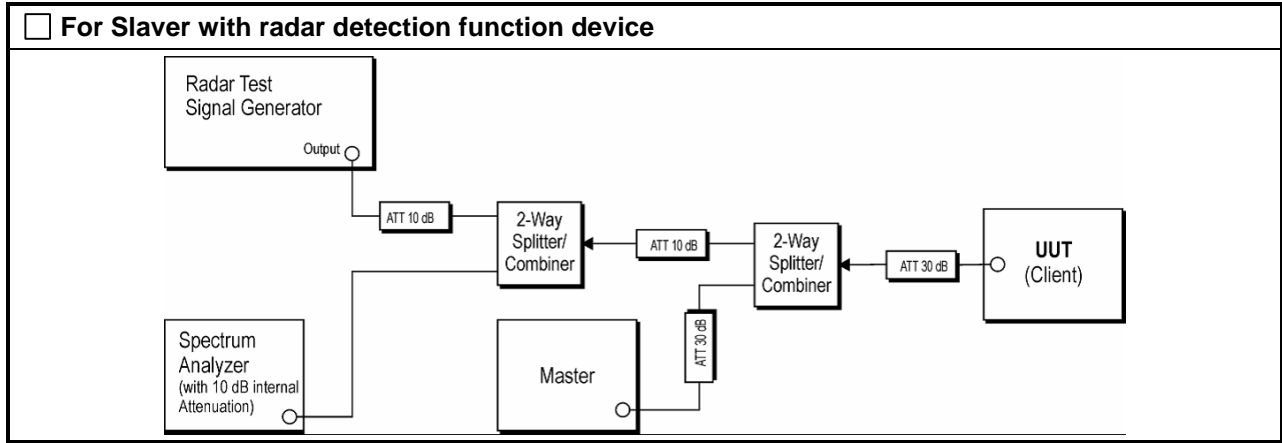

6.5 EUT Configuration for DFS Test

Test Items	Channel Frequency
Channel Move Time	5290MHz, 5320MHz, 5500MHz, 5530MHz
Channel Closing Transmission Time	5290MHz, 5320MHz, 5500MHz, 5530MHz

7 Test Result

7.1 Verification of Radar Type and Level

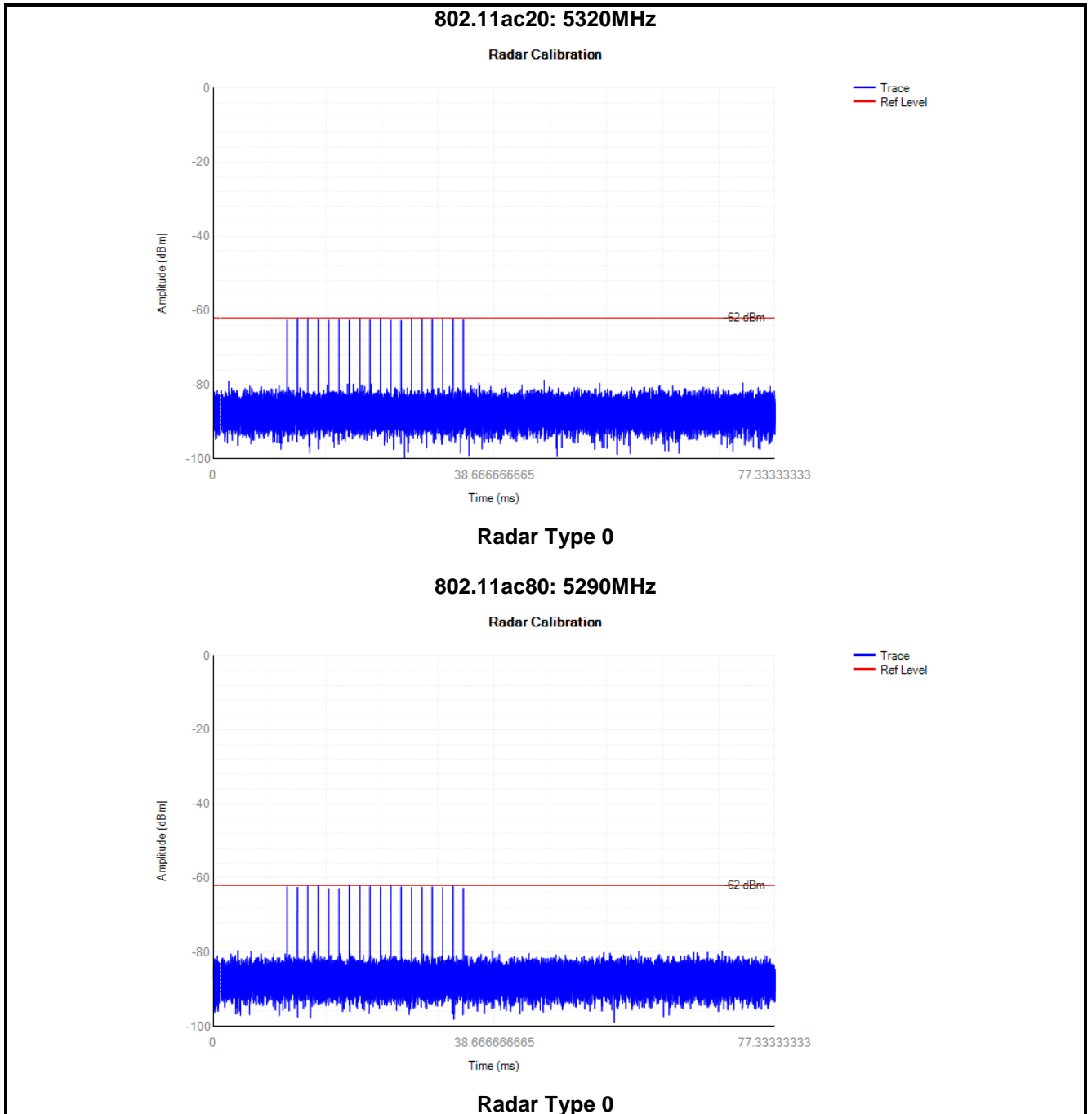

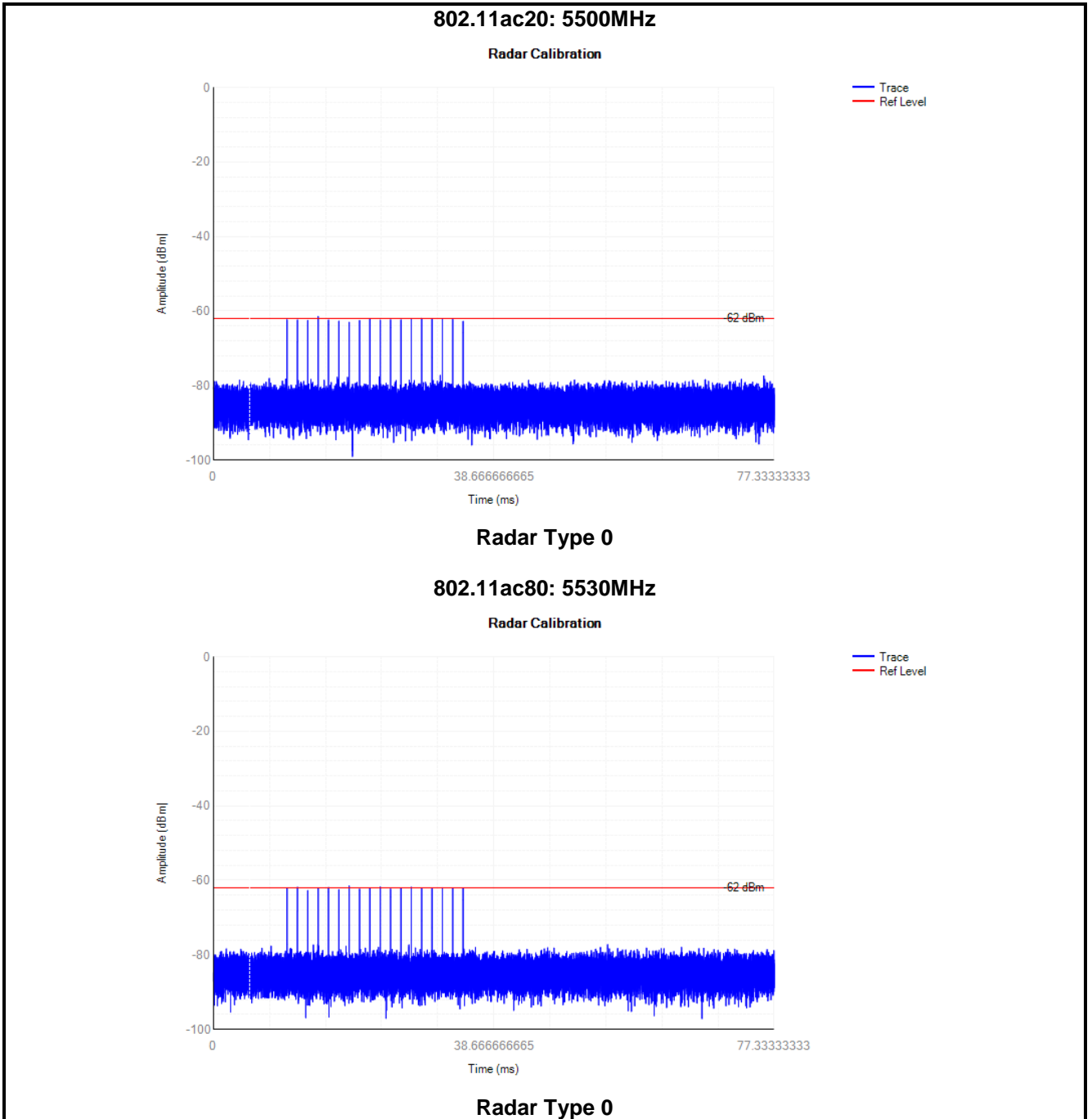

7.2 Channel Move Time and Channel Closing Transmission Time

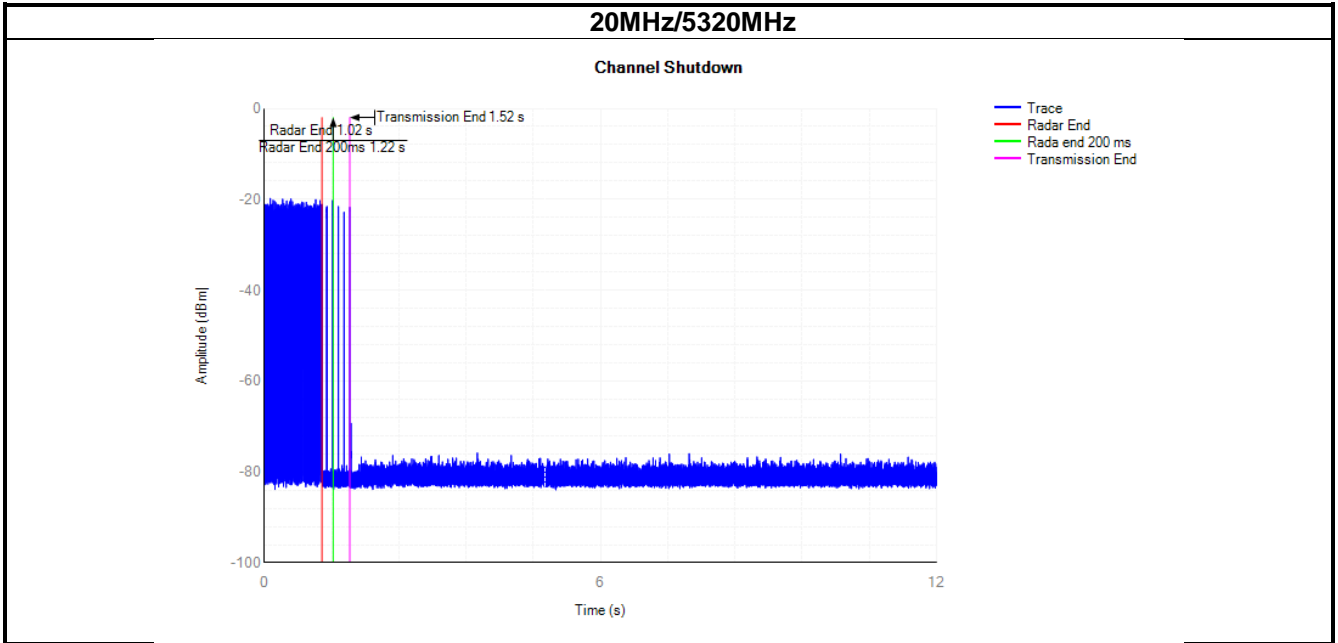

Test Items	Value	Limit
Channel Closing Transmission Time	10.5 ms	260 ms
Channel Move Time	497.3 ms	10000 ms

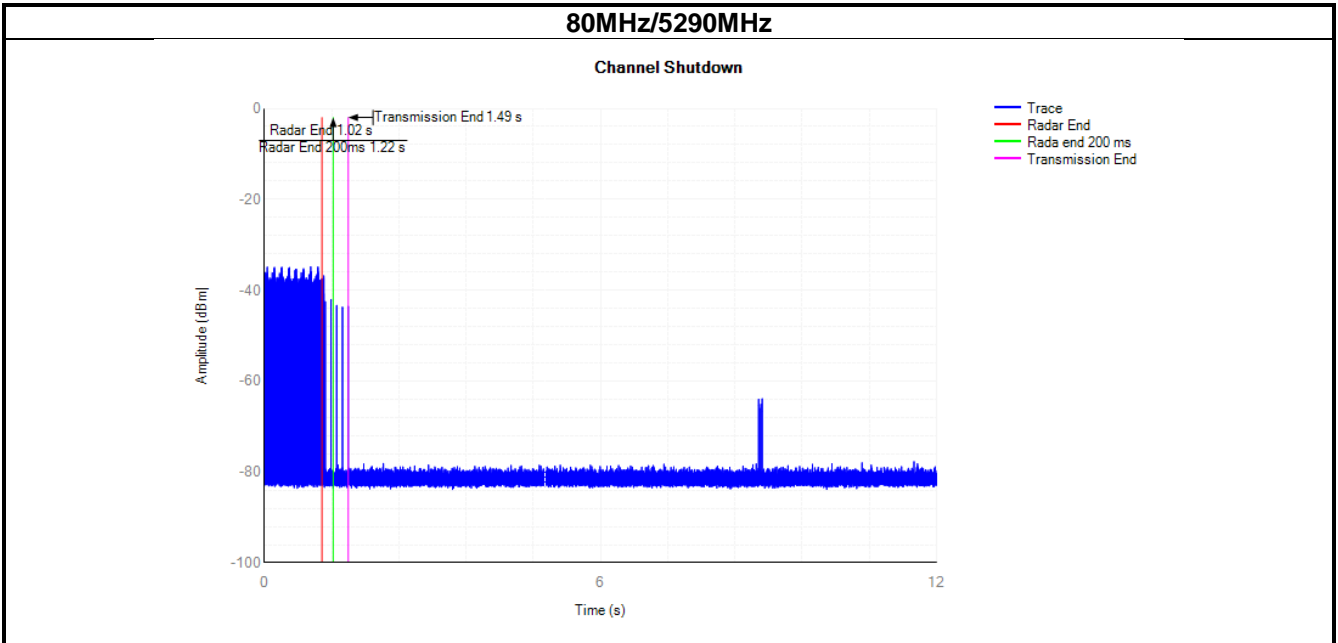

Test Items	Value	Limit
Channel Closing Transmission Time	14.1 ms	260 ms
Channel Move Time	468.8 ms	10000 ms

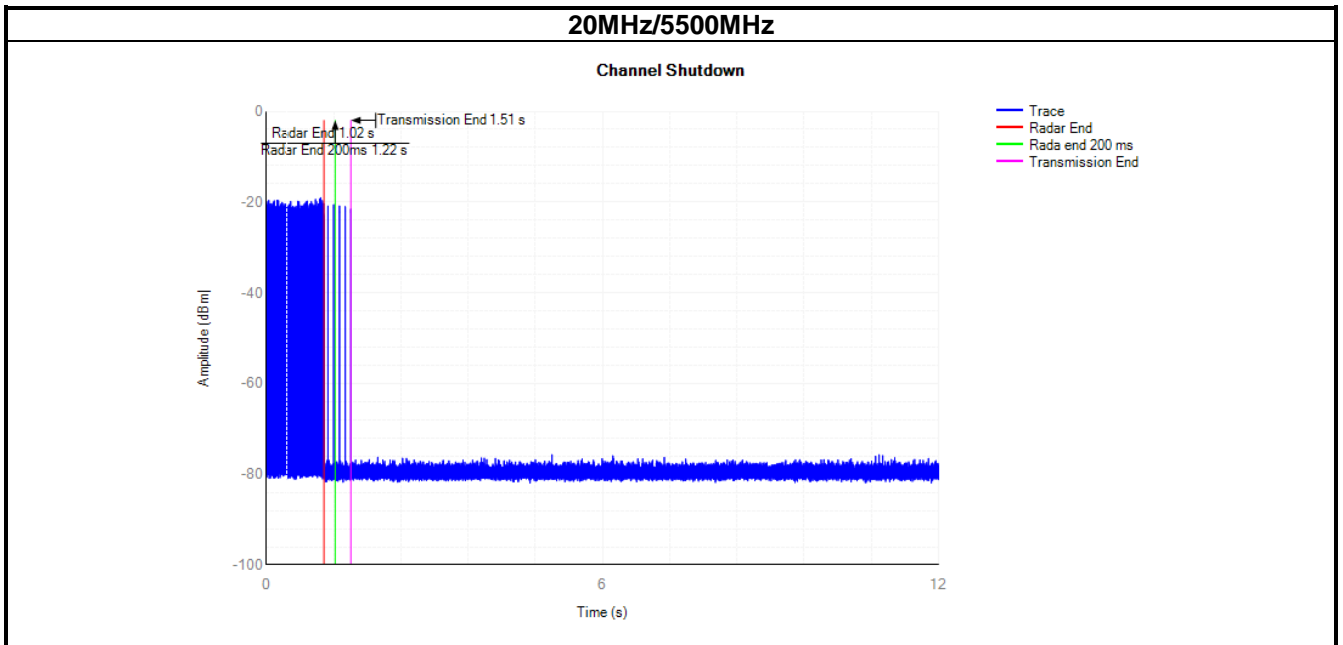

Test Items	Value	Limit
Channel Closing Transmission Time	3 ms	260 ms
Channel Move Time	481.7 ms	10000 ms

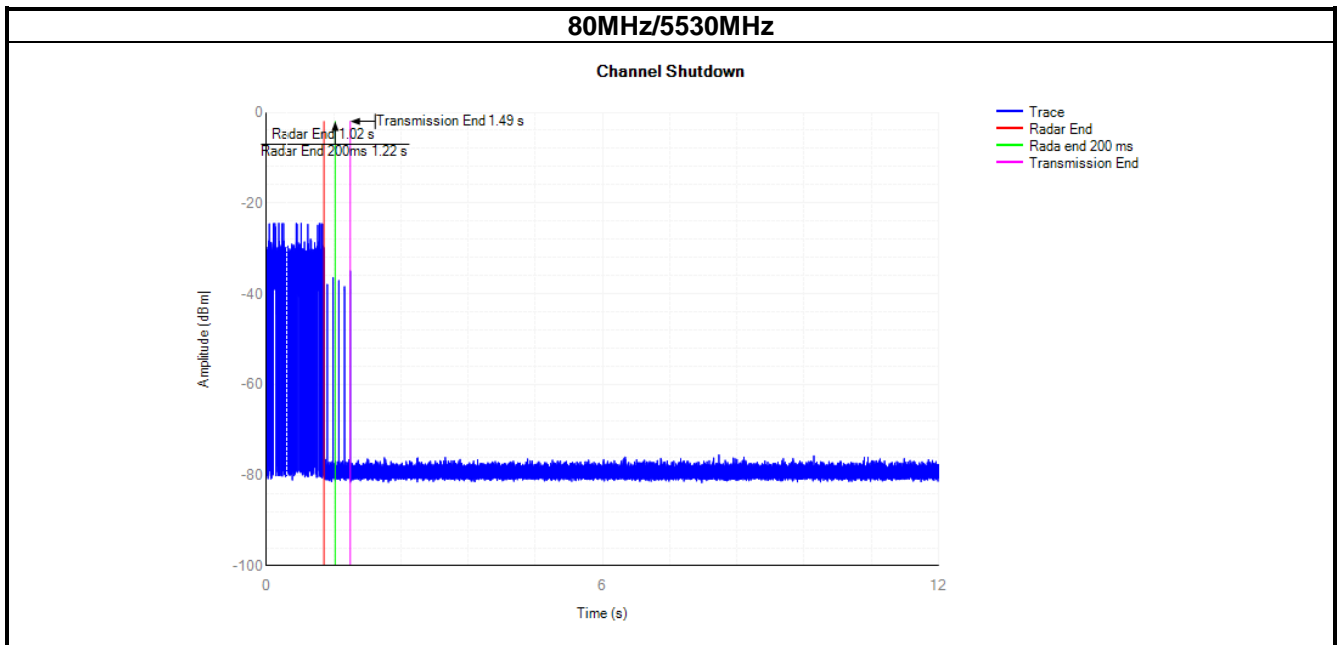

Test Items	Value	Limit
Channel Closing Transmission Time	8.4 ms	260 ms
Channel Move Time	470.3 ms	10000 ms

Test Result: Pass

8 Test Setup Photo

Reference to the Test Setup Photos.

9 EUT Constructional Details

Reference to the EUT Photos.

----- End of report -----