

FCC TEST REPORT

(Part 15, Subpart E)

Applicant:	PAX Technology Limited
Address:	Room 2416, 24/F., Sun Hung Kai Centre, 30 Harbour Hong Kong China

Manufacturer or Supplier:	PAX Computer Technology (Shenzhen) Co., Ltd.
Address:	4/F, No.3 Building, Software Park, Second Central Science-Tech Road, High-Tech industrial Park, Shenzhen, Guangdong, P.R.C.
Product:	Integrated Smart Terminal
Brand Name:	PAX
Model Name:	E700
FCC ID:	V5PE700BW
Date of tests:	Sep. 29, 2021 ~ Oct. 27, 2021

The tests have been carried out according to the requirements of the following standard:

FCC Part 15, Subpart E, Section 15.407

CONCLUSION: The submitted sample was found to COMPLY with the test requirement

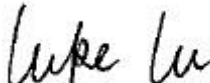
Prepared by Simon Wang Engineer / Mobile Department	Approved by Luke Lu Manager / Mobile Department
	
Date: Oct. 28, 2021	Date: Oct. 28, 2021

This report is governed by, and incorporates by reference, CPS Conditions of Service as posted at the date of issuance of this report at <http://www.bureauveritas.com/home/about-us/our-business/cps/about-us/terms-conditions> and is intended for your exclusive use. Any copying or replication of this report to or for any other person or entity, or use of our name or trademark, is permitted only with our prior written permission. This report sets forth our findings solely with respect to the test samples identified herein. The results set forth in this report are not indicative or representative of the quality or characteristics of the lot from which a test sample was taken or any similar or identical product unless specifically and expressly noted. Our report includes all of the tests requested by you and the results thereof based upon the information that you provided to us. Measurement uncertainty is only provided upon request for accredited tests. You have 60 days from date of issuance of this report to notify us of any material error or omission caused by our negligence or if you require measurement uncertainty; provided, however, that such notice shall be in writing and shall specifically address the issue you wish to raise. A failure to raise such issue within the prescribed time shall constitute your unqualified acceptance of the completeness of this report, the tests conducted and the correctness of the report contents.



TABLE OF CONTENTS

RELEASE CONTROL RECORD 4

1 SUMMARY OF TEST RESULTS 5

1.1 MEASUREMENT UNCERTAINTY 5

2 GENERAL INFORMATION..... 6

2.1 GENERAL DESCRIPTION OF EUT 6

2.2 DESCRIPTION OF TEST MODES 8

 2.2.1 TEST MODE APPLICABILITY AND TESTED CHANNEL DETAIL..... 9

2.3 DUTY CYCLE OF TEST SIGNAL 12

2.4 DESCRIPTION OF SUPPORT UNITS 13

 2.4.1 CONFIGURATION OF SYSTEM UNDER TEST 14

2.5 GENERAL DESCRIPTION OF APPLIED STANDARDS 14

3 TEST TYPES AND RESULTS..... 15

3.1 RADIATED EMISSION AND BANDEDGE MEASUREMENT..... 15

 3.1.1 LIMITS OF RADIATED EMISSION AND BANDEDGE MEASUREMENT..... 15

 3.1.2 LIMITS OF UNWANTED EMISSION..... 15

 3.1.3 TEST INSTRUMENTS..... 16

 3.1.4 TEST PROCEDURES 17

 3.1.5 DEVIATION FROM TEST STANDARD 17

 3.1.6 TEST SETUP 18

 3.1.7 EUT OPERATING CONDITION 19

 3.1.8 TEST RESULTS 20

3.2 OUT OF BAND EMISSION MEASUREMENT 36

 3.2.1 LIMITS OF OUT OF BAND EMISSION MEASUREMENT 36

 3.2.2 TEST INSTRUMENTS..... 37

 3.2.3 TEST PROCEDURES 37

 3.2.4 DEVIATION FROM TEST STANDARD 37

 3.2.5 TEST SETUP 37

 3.2.6 EUT OPERATING CONDITION 37

 3.2.7 TEST RESULTS 38

3.3 CONDUCTED EMISSION MEASUREMENT 41

 3.3.1 LIMITS OF CONDUCTED EMISSION MEASUREMENT 41

 3.3.2 TEST INSTRUMENTS..... 41

 3.3.3 TEST PROCEDURES 41



3.3.4	DEVIATION FROM TEST STANDARD	42
3.3.5	TEST SETUP	42
3.3.6	EUT OPERATING CONDITIONS	42
3.3.7	TEST RESULTS	43
3.4	MAXIMUM CONDUCTED OUTPUT POWER MEASUREMENT	45
3.4.1	LIMITS OF MAXIMUM CONDUCTED OUTPUT POWER MEASUREMENT	45
3.4.2	TEST SETUP	46
3.4.3	TEST INSTRUMENTS.....	46
3.4.4	TEST PROCEDURE.....	47
3.4.5	DEVIATION FROM TEST STANDARD	49
3.4.6	EUT OPERATING CONDITIONS	49
3.4.7	TEST RESULTS	50
3.5	MAXIMUM POWER SPECTRAL DENSITY MEASUREMENT.....	51
3.5.1	LIMITS OF MAXIMUM POWER SPECTRAL DENSITY MEASUREMENT	51
3.5.2	TEST SETUP	51
3.5.3	TEST INSTRUMENTS.....	51
3.5.4	TEST PROCEDURES	52
3.5.5	DEVIATION FROM TEST STANDARD	52
3.5.6	EUT OPERATING CONDITIONS	52
3.5.7	TEST RESULTS	52
4	PHOTOGRAPHS OF THE TEST CONFIGURATION.....	54
5	APPENDIX A – MODIFICATIONS RECORDERS FOR ENGINEERING CHANGES TO THE EUT BY THE LAB.....	55



BUREAU
VERITAS

Test Report No.: W7L-P21100003RF03

RELEASE CONTROL RECORD

ISSUE NO.	REASON FOR CHANGE	DATE ISSUED
W7L-P21100003RF03	Original release	Oct. 28, 2021



1 SUMMARY OF TEST RESULTS

The EUT has been tested according to the following specifications:

APPLIED STANDARD: FCC PART 15, SUBPART E			
STANDARD SECTION	TEST TYPE AND LIMIT	RESULT	Remark
15.407(b)(6)& 15.207 (a)	AC Power Conducted Emission	Compliance	Meet the requirement of limit.Minimum passing margin is 34.43dB at 3.368000MHz
15.407(b)(1)	Radiated Emission & Band Edge Measurement	Compliance	Meet the requirement of limit.Minimum passing margin is -3.14dB at 5150MHz
15.407(a/1)	Maximum conducted output Power	Compliance	26.42mW for 5180 ~ 5240MHz
15.407(a/1)	Peak Power Spectral Density	Compliance	Meet the requirement of limit.Minimum passing margin is -2.16dB at 5720MHz
15.407(a)	26 dB Bandwidth	Compliance	Meet the requirement of limit.Minimum passing margin is 70.197MHz at 5190MHz
15.203	Antenna Requirement	Compliance	/
15.403(i)	99% Bandwidth	Compliance	Meet the requirement of limit.Minimum passing margin is 37.683MHz at 5190MHz

1.1 MEASUREMENT UNCERTAINTY

Where relevant, the following measurement uncertainty levels have been estimated for tests performed on the EUT as specified in CISPR 16-4-2:

MEASUREMENT	UNCERTAINTY
AC Power Conducted emissions	± 2.70dB
Radiated emissions (30MHz~1GMHz)	±4.98dB
Radiated emissions (1GMHz ~6GMHz)	±4.70dB
Radiated emissions (6GMHz ~18GMHz)	±4.60dB
Radiated emissions (18GMHz ~40GMHz)	±4.12dB
Conducted emissions	± 4.01dB
Occupied Channel Bandwidth	± 43.58KHz
Conducted Output power	± 2.06dB
Power Spectral Density	±0.85 dB

This uncertainty represents an expanded uncertainty expressed at approximately the 95% confidence level using a coverage factor of k = 2.



2 GENERAL INFORMATION

2.1 GENERAL DESCRIPTION OF EUT

PRODUCT	Integrated Smart Terminal
BRAND NAME	PAX
MODEL NAME	E700
NOMINAL VOLTAGE	24Vdc (adapter) 3.63Vdc (Li-ion, battery) 3.6 Vdc (Li-ion, battery)
MODULATION	OFDM
TRANSFER RATE	802.11a: 54.0/ 48.0/ 36.0/ 24.0/ 18.0/ 12.0/ 9.0/ 6.0Mbps 802.11n: up to MCS7 802.11ac: up to 390.0Mbps
OPERATING FREQUENCY	5180 ~ 5240MHz
NUMBER OF CHANNEL	5180 ~ 5240MHz: 4 for 802.11a, 802.11n, 802.11ac (20MHz) 2 for 802.11n, 802.11ac (40MHz) 1 for 802.11ac (80MHz)
MAX AVERAGE POWER	26.42mW for 5180 ~ 5240MHz
ANTENNA TYPE	PIFA Antenna
ANTENNA GAIN	2 dBi for 5180 ~ 5240MHz
I/O PORTS	Refer to user's manual
CABLE SUPPLIED	N/A



NOTE:

1. For a more detailed features description, please refer to the manufacturer's specifications or the user's manual.
2. The EUT incorporates a SISO function. Physically, the EUT provides one completed transmitter and one receiver.

MODULATION MODE	TX FUNCTION
802.11a	1TX/1RX
802.11n/802.11ac (20MHz)	1TX/1RX
802.11n/802.11ac (40MHz)	1TX/1RX
802.11ac (80MHz)	1TX/1RX

3. For the test results, the EUT had been tested with all conditions. But only the worst case was shown in test report.

List of Accessory:

ACCESSORIES	BRAND	MODEL	SPECIFICATION
Battery1	EVE	A0671-LE	Capacity: 3.63vdc 2550mAh
Battery2	EVE	A0671B	Capacity: 3.6vdc 2550mAh
AC Adapter	HONOTO	ADS-65HI-19A-3 24065E	I/P:100-240Vac, 1.5A O/P: 24Vdc, 2.7A



2.2 DESCRIPTION OF TEST MODES

FOR 5180 ~ 5240MHz

4 channels are provided for 802.11a, 802.11n, 802.11ac (20MHz):

CHANNEL	FREQUENCY	CHANNEL	FREQUENCY
36	5180 MHz	44	5220 MHz
40	5200 MHz	48	5240 MHz

2 channels are provided for 802.11n, 802.11ac (40MHz):

CHANNEL	FREQUENCY	CHANNEL	FREQUENCY
38	5190 MHz	46	5230 MHz

1 channel is provided for 802.11ac (80MHz):

CHANNEL	FREQUENCY	CHANNEL	FREQUENCY
42	5210 MHz		



2.2.1 TEST MODE APPLICABILITY AND TESTED CHANNEL DETAIL

EUT CONFIGURE MODE	APPLICABLE TO				DESCRIPTION
	RE≥1G	RE<1G	PLC	APCM	
A	√	√	√	-	Powered by Adapter with wifi(5G) link
B	-	-	-	√	Powered by Battery with wifi(5G) link
C	-	-	-	-	Powered by USB with wifi(5G) link

Where **RE≥1G**: Radiated Emission above 1GHz **RE<1G**: Radiated Emission below 1GHz
PLC: Power Line Conducted Emission **APCM**: Antenna Port Conducted Measurement

NOTE:
The EUT had been pre-tested on the positioned of each 3 axis. The worst case was found when positioned on **X-plane**.
NOTE: “-” means no effect.

RADIATED EMISSION TEST (BELOW 1GHz):

- Pre-Scan has been conducted to determine the worst-case mode from all possible combinations between available modulations, data rates and antenna ports (if EUT with antenna diversity architecture).
- Following channel(s) was (were) selected for the final test as listed below.

EUT CONFIGURE MODE	MODE	FREQ. BAND (MHz)	AVAILABLE CHANNEL	TESTED CHANNEL	MODULATION	DATA RATE (Mbps)
A	802.11n (40MHz)	5190-5230	38 to 46	46	OFDM	MCS0



RADIATED EMISSION TEST (ABOVE 1GHz):

- Pre-Scan has been conducted to determine the worst-case mode from all possible combinations between available modulations, data rates and antenna ports (if EUT with antenna diversity architecture).
- Following channel(s) was (were) selected for the final test as listed below.

EUT CONFIGURE MODE	MODE	FREQ. BAND (MHz)	AVAILABLE CHANNEL	TESTED CHANNEL	MODULATION	DATA RATE (Mbps)
A	802.11a	5180-5240	36 to 48	36, 40, 48	OFDM	6.0
A	802.11n (20MHz)		36 to 48	36, 40, 48	OFDM	MCS0
A	802.11n (40MHz)		38 to 46	38, 46	OFDM	MCS0
A	802.11ac (20MHz)		36 to 48	36, 40, 48	OFDM	MCS0
A	802.11ac (40MHz)		38 to 46	38, 46	OFDM	MCS0
A	802.11ac (80MHz)		42	42	OFDM	MCS0

POWER LINE CONDUCTED EMISSION TEST:

- Pre-Scan has been conducted to determine the worst-case mode from all possible combinations between available modulations, data rates and antenna ports (if EUT with antenna diversity architecture).
- Following channel(s) was (were) selected for the final test as listed below.

EUT CONFIGURE MODE	MODE	FREQ. BAND (MHz)	AVAILABLE CHANNEL	TESTED CHANNEL	MODULATION	DATA RATE (Mbps)
A	802.11n (40MHz)	5180-5240	38 to 46	46	OFDM	MCS0

BANDEDGE MEASUREMENT:

- Pre-Scan has been conducted to determine the worst-case mode from all possible combinations between available modulations, data rates and antenna ports (if EUT with antenna diversity architecture).
- Following channel(s) was (were) selected for the final test as listed below.

EUT CONFIGURE MODE	MODE	FREQ. BAND (MHz)	AVAILABLE CHANNEL	TESTED CHANNEL	MODULATION	DATA RATE (Mbps)
A	802.11a	5180-5240	36 to 48	36, 48	36 to 48	6.0
A	802.11n (20MHz)		36 to 48	36, 48	36 to 48	MCS0
A	802.11n (40MHz)		38 to 46	38, 46	38 to 46	MCS0
A	802.11ac (20MHz)		36 to 48	36, 48	36 to 48	MCS0



A	802.11ac (40MHz)		38 to 46	38, 46	38 to 46	MCS0
A	802.11ac (80MHz)		42	42	42	MCS0

ANTENNA PORT CONDUCTED MEASUREMENT:

- This item includes all test value of each mode, but only includes spectrum plot of worst value of each mode.
- Pre-Scan has been conducted to determine the worst-case mode from all possible combinations between available modulations, data rates and antenna ports (if EUT with antenna diversity architecture).
- Following channel(s) was (were) selected for the final test as listed below.

EUT CONFIGURE MODE	MODE	FREQ. BAND (MHz)	AVAILABLE CHANNEL	TESTED CHANNEL	MODULATION	DATA RATE (Mbps)
A	802.11a	5180-5240	36 to 48	36, 40, 48	OFDM	6.0
A	802.11n (20MHz)		36 to 48	36, 40, 48	OFDM	MCS0
A	802.11n (40MHz)		38 to 46	38, 46	OFDM	MCS0
A	802.11ac (20MHz)		36 to 48	36, 40, 48	OFDM	MCS0
A	802.11ac (40MHz)		38 to 46	38, 46	OFDM	MCS0
A	802.11ac (80MHz)		42	42	OFDM	MCS0

TEST CONDITION:

APPLICABLE TO	ENVIRONMENTAL CONDITIONS	INPUT POWER	TESTED BY
RE<1G	23deg. C, 70%RH	24Vdc (adapter)	Star Le
RE≥1G	23deg. C, 70%RH	24Vdc (adapter)	Star Le
PLC	25deg. C, 52%RH	24Vdc (adapter)	Lily Zhao
APCM	25deg. C, 60%RH	24Vdc (adapter)	Lily Zhao



2.3 DUTY CYCLE OF TEST SIGNAL

Please Refer to Appendix A 3 Of this test report.

WORST-CASE DATA:

Measured Duty Cycles				
Mode		Duty Cycles (%)		
		ANT 0	ANT 1	ANT 0+1
5GHz	11a	97.08	/	/
	11an20	96.96	/	/
	11an40	94.34	/	/
	11ac20	96.98	/	/
	11ac40	70.15	/	/
	11ac80	62.86	/	/

Note:

Duty cycle of test signal is < 98%, duty factor shall be considered.



2.4 DESCRIPTION OF SUPPORT UNITS

The EUT has been tested as an independent unit together with other necessary accessories or support units. The following support units or accessories were used to form a representative test configuration during the tests.

NO.	PRODUCT	BRAND	MODEL NO.	SERIAL NO.	FCC ID
1	Desktop	Lenovo	M73 SFF	PC04GRQV	N/A
2	Desktop	Lenovo	M73 SFF	PC06CS27	N/A
3	Laptop	Lenovo	Thnikpad L440	R90FTFKN	N/A

NO.	SIGNAL CABLE DESCRIPTION OF THE ABOVE SUPPORT UNITS
1	AC Line: Unshielded, Detachable 1.8m
2	AC Line: Unshielded, Detachable 1.5m



2.4.1 CONFIGURATION OF SYSTEM UNDER TEST

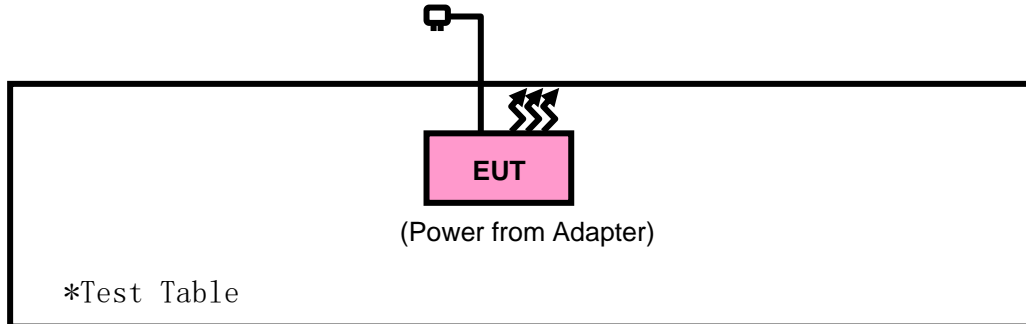

2.5 GENERAL DESCRIPTION OF APPLIED STANDARDS

The EUT is a RF Product. According to the specifications of the manufacturer, it must comply with the requirements of the following standards:

FCC Part 15, Subpart E (15.407)

KDB 789033 D02 General U-NII Test Procedures New Rules v02r01

ANSI C63.10-2013

All test items have been performed and recorded as per the above standards.

NOTE: The EUT is also considered as a kind of computer peripheral, because the connection to computer is necessary for typical use. It has been verified to comply with the requirements of FCC Part 15, Subpart B, Class B (Certification). The test report has been issued separately.



3 TEST TYPES AND RESULTS

3.1 RADIATED EMISSION AND BANDEDGE MEASUREMENT

3.1.1 LIMITS OF RADIATED EMISSION AND BANDEDGE MEASUREMENT

Radiated emissions which fall in the restricted bands must comply with the radiated emission limits specified as below table:

FREQUENCIES (MHz)	FIELD STRENGTH (microvolts/meter)	MEASUREMENT DISTANCE (meters)
0.009 ~ 0.490	2400/F(kHz)	300
0.490 ~ 1.705	24000/F(kHz)	30
1.705 ~ 30.0	30	30
30 ~ 88	100	3
88 ~ 216	150	3
216 ~ 960	200	3
Above 960	500	3

NOTE:

1. The lower limit shall apply at the transition frequencies.
2. Emission level (dBuV/m) = 20 log Emission level (uV/m).
3. For frequencies above 1000MHz, the field strength limits are based on average detector, however, the peak field strength of any emission shall not exceed the maximum permitted average limits, specified above by more than 20dB under any condition of modulation.

3.1.2 LIMITS OF UNWANTED EMISSION

RESTRICTED BANDS	APPLICABLE TO	LIMIT	
	789033 D02 General UNII Test Procedures New Rules v02r01	FIELD STRENGTH AT 3m (dBµV/m)	
	PK : 74	AV : 54	
OUT OF THE RESTRICTED BANDS	APPLICABLE TO	EIRP LIMIT (dBm/MHz)	EQUIVALENT FIELD STRENGTH AT 3m (dBµV/m)
	15.407(b)(1)	PK : -27	PK : 68.2
	15.407(b)(2)		
	15.407(b)(3)		
	15.407(b)(4)	See note 2 (FCC 16-24)	



NOTE: The following formula is used to convert the equipment isotropic radiated power (eirp) to field strength:

$$E = \frac{1000000\sqrt{30P}}{3} \mu\text{V/m, where P is the eirp (Watts).}$$

2. All emissions shall be limited to a level of -27 dBm/MHz at 75 MHz or more above or below the band edge increasing linearly to 10 dBm/MHz at 25 MHz above or below the band edge, and from 25 MHz above or below the band edge increasing linearly to a level of 15.6 dBm/MHz at 5 MHz above or below the band edge, and from 5 MHz above or below the band edge increasing linearly to a level of 27 dBm/MHz at the band edge.

3.1.3 TEST INSTRUMENTS

Equipment	Manufacturer	Model No.	Serial No.	Last Cal.	Next Cal.
3m Semi-anechoic Chamber	ETS-LINDGREN	9m*6m*6m	Euroshieldpn-CT0001143-1216	May. 19,20	May. 18,23
Bilog Antenna	ETS-LINDGREN	3143B	00161965	Mar. 05,21	Mar. 04,22
Horn Antenna	ETS-LINDGREN	3117	00168728	Apr. 02,21	Apr. 01,22
Horn Antenna (18GHz-40GHz)	N/A	QWH-SL-18-40-K-SG/QMS-00361	15433	Aug. 25, 21	Aug. 24, 22
Test Software	E3	V 9.160323	N/A	N/A	N/A
Test Software	ADT	ADT_Radiated_V7.6.15.9.2	N/A	N/A	N/A
10dB Attenuator	JFW/USA	50HF-010-SMA	1505	Jun. 03,21	Jun. 02,22
MXE EMI Receiver	KEYSIGHT	N9038A-544	MY54450026	Apr. 22,21	Apr. 21,22
Signal Pre-Amplifier	EMSI	EMC 9135	980249	Jun. 02,21	Jun. 01,22
Signal Pre-Amplifier	EMSI	EMC 012645B	980257	Jun. 03,21	Jun. 02,22
Signal Pre-Amplifier	EMSI	EMC 184045B	980259	Apr. 22,21	Apr. 21,22

NOTE:

1. The calibration interval of the above test instruments is 12 months or 36 months and the calibrations are traceable to CEPREI/CHINA, GRGT/CHINA and NIM/CHINA.
2. The test was performed in 3m Chamber.
3. The FCC Site Registration No. is 525120; The Designation No. is CN1171.



3.1.4 TEST PROCEDURES

- a. The EUT was placed on the top of a rotating table 0.8 meters (for below 1GHz) / 1.5 meters (for above 1GHz) above the ground at 3 meter chamber room for test. The table was rotated 360 degrees to determine the position of the highest radiation.
- b. The EUT was set 3 meters away from the interference-receiving antenna, which was mounted on the top of a variable-height antenna tower.
- c. The antenna is a broadband antenna, and its height is varied from one meter to four meters above the ground to determine the maximum value of the field strength. Both horizontal and vertical polarizations of the antenna are set to make the measurement.
- d. For each suspected emission, the EUT was arranged to its worst case and then the antenna was tuned to heights from 1 meter to 4 meters and the rotatable table was turned from 0 degrees to 360 degrees to find the maximum reading.
- e. The test-receiver system was set to Peak Detect Function and Specified Bandwidth with Maximum Hold Mode.
- f. If the emission level of the EUT in peak mode was 10dB lower than the limit specified, then testing could be stopped and the peak values of the EUT would be reported. Otherwise the emissions that did not have 10dB margin would be re-tested one by one using peak, quasi-peak or average method as specified and then reported in a data sheet.

NOTE:

1. The resolution bandwidth and video bandwidth of test receiver/spectrum analyzer is 120kHz for Peak detection (PK) and Quasi-peak detection (QP) at frequency below 1GHz.
2. The resolution bandwidth of test receiver/spectrum analyzer is 1MHz and video bandwidth is 3MHz for Peak detection at frequency above 1GHz.
3. The resolution bandwidth of test receiver/spectrum analyzer is 1MHz and the video bandwidth is 3MHz for RMS Average (Duty cycle < 98%) for Average detection (AV) at frequency above 1GHz, then the measurement results was added to a correction factor ($10 \log(1/\text{duty cycle})$).
4. The resolution bandwidth of test receiver/spectrum analyzer is 1MHz and the video bandwidth is 10Hz (Duty cycle $\geq 98\%$) for Average detection (AV) at frequency above 1GHz.
5. All modes of operation were investigated and the worst-case emissions are reported.

3.1.5 DEVIATION FROM TEST STANDARD

No deviation.



3.1.6 TEST SETUP

< Frequency Range 30MHz~1GHz >

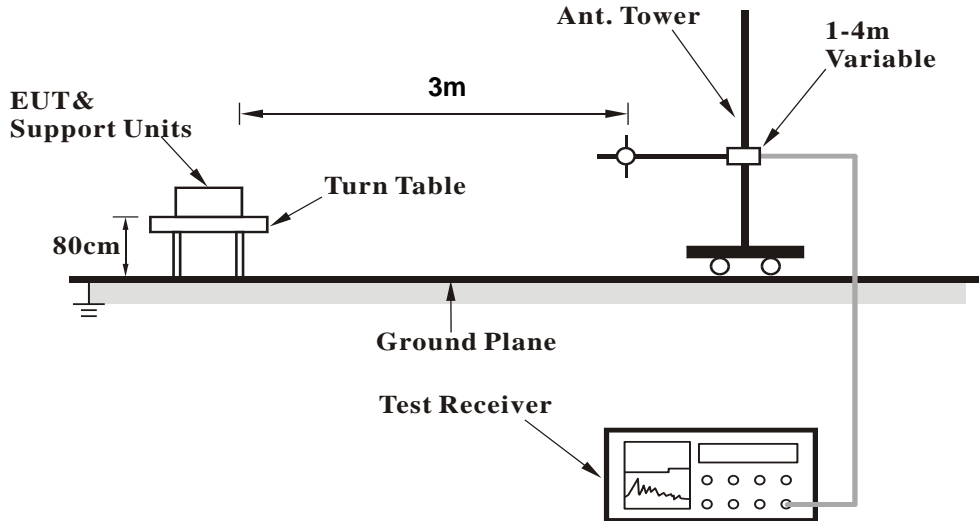

<Frequency Range above 1GHz>

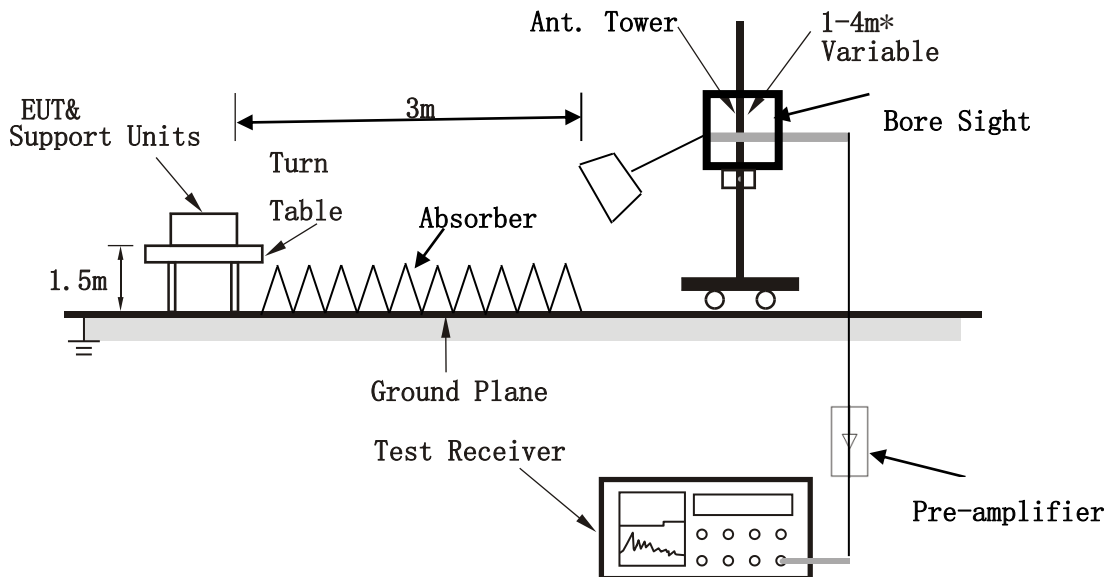

Note: Above 1G is a directional antenna

Depends on the EUT height and the antenna 3dB beamwidth both, refer to section 7.3 of CISPR 16-2-3.

For the actual test configuration, please refer to the attached file (Test Setup Photo).



3.1.7 EUT OPERATING CONDITION

- a. Set the EUT under full load condition and placed them on a testing table.
- b. Set the transmitter part of EUT under transmission condition continuously at specific channel frequency.
- c. The necessary accessories enable the EUT in full functions.



3.1.8 TEST RESULTS

BELOW 1GHz WORST-CASE DATA:

30 MHz – 1GHz data:

Band 1

802.11n (40MHz)

CHANNEL	TX Channel 46	DETECTOR FUNCTION	Quasi-Peak (QP)
FREQUENCY RANGE	30MHz ~ 1GHz		

ANTENNA POLARITY & TEST DISTANCE: HORIZONTAL AT 3 M										
FREQ. (MHz)	EMISSION LEVEL (dBuV/m)	READ LEVEL (dBuV)	LIMIT (dBuV/m)	MARGIN (dB)	ANTENNA FACTOR (dB /m)	CABLE LOSS (dB)	PREAMP FACTOR (dB)	ANTENNA HEIGHT (cm)	TABLE ANGLE (Degree)	REMARK
53.28	33.51	61.62	40	-6.49	8.27	0.94	37.32	200	360	QP
144.46	34.09	60.61	43.5	-9.41	8.82	1.53	36.87	200	360	QP
192.96	36.36	60.46	43.5	-7.14	10.72	1.76	36.58	200	360	QP
306.45	36.97	57.31	46	-9.03	14.19	2.23	36.76	200	360	QP
375.32	36.28	54.44	46	-9.72	16.18	2.47	36.81	200	360	QP
450.01	35.05	51.43	46	-10.95	17.8	2.74	36.92	200	360	QP

REMARKS:

1. Emission level (dBuV/m) = Read level (dBuV) + Correction Factor (dB/m).
2. Correction Factor (dB/m) = Antenna Factor (dB/m) + Cable Factor (dB).
3. The other emission levels were very low against the limit.
4. Margin value = Emission level – Limit value.

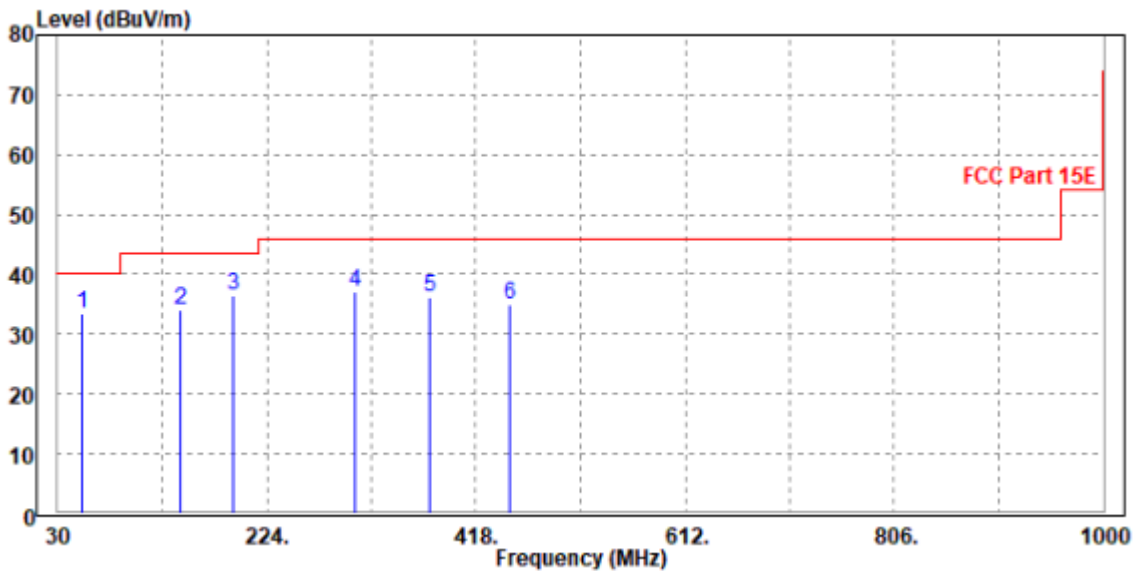



CHANNEL	Channel 46	DETECTOR FUNCTION	Quasi-Peak (QP)
FREQUENCY RANGE	30MHz ~ 1GHz		

ANTENNA POLARITY & TEST DISTANCE: VERTICAL AT 3 M										
FREQ. (MHz)	EMISSION LEVEL (dBuV/m)	READ LEVEL (dBuV)	LIMIT (dBuV/m)	MARGIN (dB)	ANTENNA FACTOR (dB /m)	CABLE LOSS (dB)	PREAMP FACTOR (dB)	ANTENNA HEIGHT (cm)	TABLE ANGLE (Degree)	REMARK
53.28	30.79	58.53	40	-9.21	8.64	0.94	37.32	300	360	QP
197.81	31.54	54.94	43.5	-11.96	11.37	1.79	36.56	300	360	QP
323.91	34.52	53.47	46	-11.48	15.53	2.29	36.77	300	360	QP
375.32	35.04	52.72	46	-10.96	16.66	2.47	36.81	300	360	QP
450.01	36.71	52.74	46	-9.29	18.15	2.74	36.92	300	360	QP
500.45	35.33	50.29	46	-10.67	19.11	2.93	37	300	360	QP

REMARKS:

1. Emission level (dBuV/m) = Read level (dBuV) + Correction Factor (dB/m).
2. Correction Factor (dB/m) = Antenna Factor (dB/m) + Cable Factor (dB).
3. The other emission levels were very low against the limit.
4. Margin value = Emission level – Limit value.

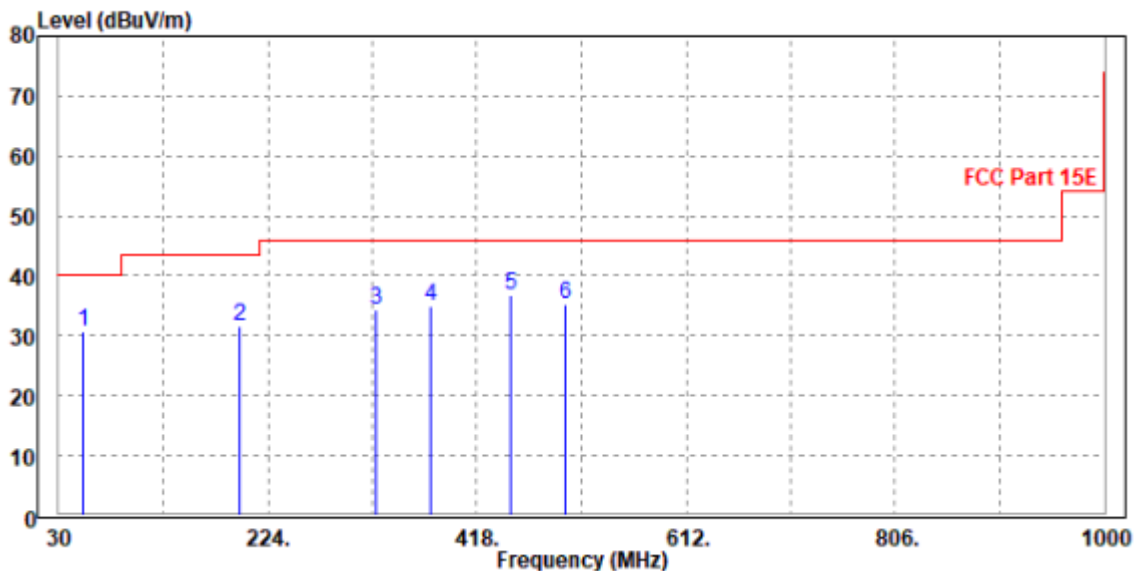



ABOVE 1GHz WORST-CASE DATA:

Note: For higher frequency, the emission is too low to be detected.

Band 1

802.11a

CHANNEL	TX Channel 36	DETECTOR FUNCTION	Peak (PK)
FREQUENCY RANGE	1GHz ~ 40GHz		Average (AV)

ANTENNA POLARITY & TEST DISTANCE: HORIZONTAL AT 3 M

FREQ. (MHz)	EMISSION LEVEL (dBuV/m)	READ LEVEL (dBuV)	LIMIT (dBuV/m)	MARGIN (dB)	ANTENNA FACTOR (dB /m)	CABLE LOSS (dB)	PREAMP FACTOR (dB)	ANTENNA HEIGHT (cm)	TABLE ANGLE (Degree)	REMARK
5150	57.86	60.17	74	-16.14	34.52	9.52	46.35	100	290	Peak
5150	48.44	50.75	54	-5.56	34.52	9.52	46.35	100	290	Average
5180	88.15	90.38	-	-	34.54	9.58	46.35	100	290	Peak
5180	81.47	83.7	-	-	34.54	9.58	46.35	100	290	Average
5350	55	56.68	74	-19	34.68	9.94	46.3	100	290	Peak
5350	48.36	50.04	54	-5.64	34.68	9.94	46.3	100	290	Average

ANTENNA POLARITY & TEST DISTANCE: VERTICAL AT 3 M

FREQ. (MHz)	EMISSION LEVEL (dBuV/m)	READ LEVEL (dBuV)	LIMIT (dBuV/m)	MARGIN (dB)	ANTENNA FACTOR (dB /m)	CABLE LOSS (dB)	PREAMP FACTOR (dB)	ANTENNA HEIGHT (cm)	TABLE ANGLE (Degree)	REMARK
5150	55.72	57.95	74	-18.28	34.6	9.52	46.35	105	95	Peak
5150	50.3	52.53	54	-3.7	34.6	9.52	46.35	105	95	Average
5180	92.41	94.58	-	-	34.6	9.58	46.35	105	95	Peak
5180	85.98	88.15	-	-	34.6	9.58	46.35	105	95	Average
5350	53.44	55.2	74	-20.56	34.6	9.94	46.3	105	95	Peak
5350	48.77	50.53	54	-5.23	34.6	9.94	46.3	105	95	Average

REMARKS:

- Emission Level = Read Level+ Antenna Factor + Cable Loss- Preamp Factor
Margin value = Emission level – Limit value.
- 5180MHz: Fundamental frequency.



CHANNEL	TX Channel 40	DETECTOR FUNCTION	Peak (PK)
FREQUENCY RANGE	1GHz ~ 40GHz		Average (AV)

ANTENNA POLARITY & TEST DISTANCE: HORIZONTAL AT 3 M

FREQ. (MHz)	EMISSION LEVEL (dBuV/m)	READ LEVEL (dBuV)	LIMIT (dBuV/m)	MARGIN (dB)	ANTENNA FACTOR (dB /m)	CABLE LOSS (dB)	PREAMP FACTOR (dB)	ANTENNA HEIGHT (cm)	TABLE ANGLE (Degree)	REMARK
5150	54.92	57.23	74	-19.08	34.52	9.52	46.35	100	290	Peak
5150	48.21	50.52	54	-5.79	34.52	9.52	46.35	100	290	Average
5200	90.67	92.83	-	-	34.56	9.62	46.34	100	290	Peak
5200	84.23	86.39	-	-	34.56	9.62	46.34	100	290	Average
5350	53.46	55.14	74	-20.54	34.68	9.94	46.3	100	290	Peak
5350	47.54	49.22	54	-6.46	34.68	9.94	46.3	100	290	Average

ANTENNA POLARITY & TEST DISTANCE: VERTICAL AT 3 M

FREQ. (MHz)	EMISSION LEVEL (dBuV/m)	READ LEVEL (dBuV)	LIMIT (dBuV/m)	MARGIN (dB)	ANTENNA FACTOR (dB /m)	CABLE LOSS (dB)	PREAMP FACTOR (dB)	ANTENNA HEIGHT (cm)	TABLE ANGLE (Degree)	REMARK
5150	56.65	58.88	74	-17.35	34.6	9.52	46.35	105	95	Peak
5150	49.82	52.05	54	-4.18	34.6	9.52	46.35	105	95	Average
5200	94.99	97.11	-	-	34.6	9.62	46.34	105	95	Peak
5200	88.57	90.69	-	-	34.6	9.62	46.34	105	95	Average
5350	53.77	55.53	74	-20.23	34.6	9.94	46.3	105	95	Peak
5350	47.27	49.03	54	-6.73	34.6	9.94	46.3	105	95	Average

REMARKS:

- Emission Level = Read Level+ Antenna Factor + Cable Loss- Preamp Factor
Margin value = Emission level – Limit value.
- 5200MHz: Fundamental frequency.



CHANNEL	TX Channel 48	DETECTOR FUNCTION	Peak (PK)
FREQUENCY RANGE	1GHz ~ 40GHz		Average (AV)

ANTENNA POLARITY & TEST DISTANCE: HORIZONTAL AT 3 M										
FREQ. (MHz)	EMISSION LEVEL (dBuV/m)	READ LEVEL (dBuV)	LIMIT (dBuV/m)	MARGIN (dB)	ANTENNA FACTOR (dB /m)	CABLE LOSS (dB)	PREAMP FACTOR (dB)	ANTENNA HEIGHT (cm)	TABLE ANGLE (Degree)	REMARK
5150	53.91	56.22	74	-20.09	34.52	9.52	46.35	100	290	Peak
5150	48.07	50.38	54	-5.93	34.52	9.52	46.35	100	290	Average
5240	90.35	92.38	-	-	34.59	9.71	46.33	100	290	Peak
5240	84.09	86.12	-	-	34.59	9.71	46.33	100	290	Average
5350	53.36	55.04	74	-20.64	34.68	9.94	46.3	100	290	Peak
5350	47.7	49.38	54	-6.3	34.68	9.94	46.3	100	290	Average
ANTENNA POLARITY & TEST DISTANCE: VERTICAL AT 3 M										
FREQ. (MHz)	EMISSION LEVEL (dBuV/m)	READ LEVEL (dBuV)	LIMIT (dBuV/m)	MARGIN (dB)	ANTENNA FACTOR (dB /m)	CABLE LOSS (dB)	PREAMP FACTOR (dB)	ANTENNA HEIGHT (cm)	TABLE ANGLE (Degree)	REMARK
5150	54.68	56.91	74	-19.32	34.6	9.52	46.35	105	95	Peak
5150	48.09	50.32	54	-5.91	34.6	9.52	46.35	105	95	Average
5240	94.96	96.98	-	-	34.6	9.71	46.33	105	95	Peak
5240	88.59	90.61	-	-	34.6	9.71	46.33	105	95	Average
5350	54.56	56.32	74	-19.44	34.6	9.94	46.3	105	95	Peak
5350	47.89	49.65	54	-6.11	34.6	9.94	46.3	105	95	Average

REMARKS:

- Emission Level = Read Level+ Antenna Factor + Cable Loss- Preamp Factor
Margin value = Emission level – Limit value.
- 5240MHz: Fundamental frequency.



802.11n (20MHz)

CHANNEL	TX Channel 36	DETECTOR FUNCTION	Peak (PK)
FREQUENCY RANGE	1GHz ~ 40GHz		Average (AV)

ANTENNA POLARITY & TEST DISTANCE: HORIZONTAL AT 3 M

FREQ. (MHz)	EMISSION LEVEL (dBuV/m)	READ LEVEL (dBuV)	LIMIT (dBuV/m)	MARGIN (dB)	ANTENNA FACTOR (dB /m)	CABLE LOSS (dB)	PREAMP FACTOR (dB)	ANTENNA HEIGHT (cm)	TABLE ANGLE (Degree)	REMARK
5150	55.48	57.79	74	-18.52	34.52	9.52	46.35	100	290	Peak
5150	48.9	51.21	54	-5.1	34.52	9.52	46.35	100	290	Average
5180	88.53	90.76	-	-	34.54	9.58	46.35	100	290	Peak
5180	81.15	83.38	-	-	34.54	9.58	46.35	100	290	Average
5350	53.81	55.49	74	-20.19	34.68	9.94	46.3	100	290	Peak
5350	48.05	49.73	54	-5.95	34.68	9.94	46.3	100	290	Average

ANTENNA POLARITY & TEST DISTANCE: VERTICAL AT 3 M

FREQ. (MHz)	EMISSION LEVEL (dBuV/m)	READ LEVEL (dBuV)	LIMIT (dBuV/m)	MARGIN (dB)	ANTENNA FACTOR (dB /m)	CABLE LOSS (dB)	PREAMP FACTOR (dB)	ANTENNA HEIGHT (cm)	TABLE ANGLE (Degree)	REMARK
5150	56.26	58.49	74	-17.74	34.6	9.52	46.35	105	95	Peak
5150	50.24	52.47	54	-3.76	34.6	9.52	46.35	105	95	Average
5180	92.77	94.94	-	-	34.6	9.58	46.35	105	95	Peak
5180	85.98	88.15	-	-	34.6	9.58	46.35	105	95	Average
5350	54	55.76	74	-20	34.6	9.94	46.3	105	95	Peak
5350	48.44	50.2	54	-5.56	34.6	9.94	46.3	105	95	Average

REMARKS:

- Emission Level = Read Level+ Antenna Factor + Cable Loss- Preamp Factor
Margin value = Emission level – Limit value.
- 5180MHz: Fundamental frequency.



CHANNEL	TX Channel 40	DETECTOR FUNCTION	Peak (PK)
FREQUENCY RANGE	1GHz ~ 40GHz		Average (AV)

ANTENNA POLARITY & TEST DISTANCE: HORIZONTAL AT 3 M

FREQ. (MHz)	EMISSION LEVEL (dBuV/m)	READ LEVEL (dBuV)	LIMIT (dBuV/m)	MARGIN (dB)	ANTENNA FACTOR (dB /m)	CABLE LOSS (dB)	PREAMP FACTOR (dB)	ANTENNA HEIGHT (cm)	TABLE ANGLE (Degree)	REMARK
5150	56.17	58.48	74	-17.83	34.52	9.52	46.35	100	290	Peak
5150	49.16	51.47	54	-4.84	34.52	9.52	46.35	100	290	Average
5200	91.03	93.19	-	-	34.56	9.62	46.34	100	290	Peak
5200	84.3	86.46	-	-	34.56	9.62	46.34	100	290	Average
5350	55.42	57.1	74	-18.58	34.68	9.94	46.3	100	290	Peak
5350	48	49.68	54	-6	34.68	9.94	46.3	100	290	Average

ANTENNA POLARITY & TEST DISTANCE: VERTICAL AT 3 M

FREQ. (MHz)	EMISSION LEVEL (dBuV/m)	READ LEVEL (dBuV)	LIMIT (dBuV/m)	MARGIN (dB)	ANTENNA FACTOR (dB /m)	CABLE LOSS (dB)	PREAMP FACTOR (dB)	ANTENNA HEIGHT (cm)	TABLE ANGLE (Degree)	REMARK
5150	58.23	60.46	74	-15.77	34.6	9.52	46.35	105	95	Peak
5150	50.81	53.04	54	-3.19	34.6	9.52	46.35	105	95	Average
5200	95.51	97.63	-	-	34.6	9.62	46.34	105	95	Peak
5200	88.92	91.04	-	-	34.6	9.62	46.34	105	95	Average
5350	55.47	57.23	74	-18.53	34.6	9.94	46.3	105	95	Peak
5350	47.78	49.54	54	-6.22	34.6	9.94	46.3	105	95	Average

REMARKS:

1. Emission Level = Read Level+ Antenna Factor + Cable Loss- Preamp Factor
Margin value = Emission level – Limit value.
2. 5200MHz: Fundamental frequency.



CHANNEL	TX Channel 48	DETECTOR FUNCTION	Peak (PK)
FREQUENCY RANGE	1GHz ~ 40GHz		Average (AV)

ANTENNA POLARITY & TEST DISTANCE: HORIZONTAL AT 3 M

FREQ. (MHz)	EMISSION LEVEL (dBuV/m)	READ LEVEL (dBuV)	LIMIT (dBuV/m)	MARGIN (dB)	ANTENNA FACTOR (dB /m)	CABLE LOSS (dB)	PREAMP FACTOR (dB)	ANTENNA HEIGHT (cm)	TABLE ANGLE (Degree)	REMARK
5150	56.1	58.41	74	-17.9	34.52	9.52	46.35	100	290	Peak
5150	48.12	50.43	54	-5.88	34.52	9.52	46.35	100	290	Average
5240	90.25	92.28	-	-	34.59	9.71	46.33	100	290	Peak
5240	83.87	85.9	-	-	34.59	9.71	46.33	100	290	Average
5350	54.68	56.36	74	-19.32	34.68	9.94	46.3	100	290	Peak
5350	47.45	49.13	54	-6.55	34.68	9.94	46.3	100	290	Average

ANTENNA POLARITY & TEST DISTANCE: VERTICAL AT 3 M

FREQ. (MHz)	EMISSION LEVEL (dBuV/m)	READ LEVEL (dBuV)	LIMIT (dBuV/m)	MARGIN (dB)	ANTENNA FACTOR (dB /m)	CABLE LOSS (dB)	PREAMP FACTOR (dB)	ANTENNA HEIGHT (cm)	TABLE ANGLE (Degree)	REMARK
5150	56.39	58.62	74	-17.61	34.6	9.52	46.35	105	95	Peak
5150	48.43	50.66	54	-5.57	34.6	9.52	46.35	105	95	Average
5240	94.43	96.45	-	-	34.6	9.71	46.33	105	95	Peak
5240	88.24	90.26	-	-	34.6	9.71	46.33	105	95	Average
5350	55.25	57.01	74	-18.75	34.6	9.94	46.3	105	95	Peak
5350	47.28	49.04	54	-6.72	34.6	9.94	46.3	105	95	Average

REMARKS:

- Emission Level = Read Level+ Antenna Factor + Cable Loss- Preamp Factor
Margin value = Emission level – Limit value.
- 5240MHz: Fundamental frequency.



802.11n (40MHz)

CHANNEL	TX Channel 38	DETECTOR FUNCTION	Peak (PK)
FREQUENCY RANGE	1GHz ~ 40GHz		Average (AV)

ANTENNA POLARITY & TEST DISTANCE: HORIZONTAL AT 3 M

FREQ. (MHz)	EMISSION LEVEL (dBuV/m)	READ LEVEL (dBuV)	LIMIT (dBuV/m)	MARGIN (dB)	ANTENNA FACTOR (dB /m)	CABLE LOSS (dB)	PREAMP FACTOR (dB)	ANTENNA HEIGHT (cm)	TABLE ANGLE (Degree)	REMARK
5150	53.95	56.26	74	-20.05	34.52	9.52	46.35	100	290	Peak
5150	49.6	51.91	54	-4.4	34.52	9.52	46.35	100	290	Average
5190	82.25	84.44	-	-	34.55	9.6	46.34	100	290	Peak
5190	76.91	79.1	-	-	34.55	9.6	46.34	100	290	Average
5350	53.18	54.86	74	-20.82	34.68	9.94	46.3	100	290	Peak
5350	48.42	50.1	54	-5.58	34.68	9.94	46.3	100	290	Average

ANTENNA POLARITY & TEST DISTANCE: VERTICAL AT 3 M

FREQ. (MHz)	EMISSION LEVEL (dBuV/m)	READ LEVEL (dBuV)	LIMIT (dBuV/m)	MARGIN (dB)	ANTENNA FACTOR (dB /m)	CABLE LOSS (dB)	PREAMP FACTOR (dB)	ANTENNA HEIGHT (cm)	TABLE ANGLE (Degree)	REMARK
5150	57.54	59.77	74	-16.46	34.6	9.52	46.35	105	95	Peak
5150	50.8	53.03	54	-3.2	34.6	9.52	46.35	105	95	Average
5190	86.79	88.93	-	-	34.6	9.6	46.34	105	95	Peak
5190	81.09	83.23	-	-	34.6	9.6	46.34	105	95	Average
5350	53.48	55.24	74	-20.52	34.6	9.94	46.3	105	95	Peak
5350	48.04	49.8	54	-5.96	34.6	9.94	46.3	105	95	Average

REMARKS:

- Emission Level = Read Level+ Antenna Factor + Cable Loss- Preamp Factor
Margin value = Emission level – Limit value.
- 5190MHz: Fundamental frequency.



CHANNEL	TX Channel 46	DETECTOR FUNCTION	Peak (PK)
FREQUENCY RANGE	1GHz ~ 40GHz		Average (AV)

ANTENNA POLARITY & TEST DISTANCE: HORIZONTAL AT 3 M

FREQ. (MHz)	EMISSION LEVEL (dBuV/m)	READ LEVEL (dBuV)	LIMIT (dBuV/m)	MARGIN (dB)	ANTENNA FACTOR (dB /m)	CABLE LOSS (dB)	PREAMP FACTOR (dB)	ANTENNA HEIGHT (cm)	TABLE ANGLE (Degree)	REMARK
5150	57.46	59.77	74	-16.54	34.52	9.52	46.35	100	290	Peak
5150	49.91	52.22	54	-4.09	34.52	9.52	46.35	100	290	Average
5230	85.89	87.95	-	-	34.58	9.69	46.33	100	290	Peak
5230	80.6	82.66	-	-	34.58	9.69	46.33	100	290	Average
5350	53.8	55.48	74	-20.2	34.68	9.94	46.3	100	290	Peak
5350	47.84	49.52	54	-6.16	34.68	9.94	46.3	100	290	Average

ANTENNA POLARITY & TEST DISTANCE: VERTICAL AT 3 M

FREQ. (MHz)	EMISSION LEVEL (dBuV/m)	READ LEVEL (dBuV)	LIMIT (dBuV/m)	MARGIN (dB)	ANTENNA FACTOR (dB /m)	CABLE LOSS (dB)	PREAMP FACTOR (dB)	ANTENNA HEIGHT (cm)	TABLE ANGLE (Degree)	REMARK
5150	57.52	59.75	74	-16.48	34.6	9.52	46.35	105	95	Peak
5150	50.86	53.09	54	-3.14	34.6	9.52	46.35	105	95	Average
5230	90.64	92.68	-	-	34.6	9.69	46.33	105	95	Peak
5230	85.58	87.62	-	-	34.6	9.69	46.33	105	95	Average
5350	52.53	54.29	74	-21.47	34.6	9.94	46.3	105	95	Peak
5350	47.64	49.4	54	-6.36	34.6	9.94	46.3	105	95	Average

REMARKS:

- Emission Level = Read Level+ Antenna Factor + Cable Loss- Preamp Factor
Margin value = Emission level – Limit value.
- 5230MHz: Fundamental frequency.



802.11ac (20MHz)

CHANNEL	TX Channel 36	DETECTOR FUNCTION	Peak (PK)
FREQUENCY RANGE	1GHz ~ 40GHz		Average (AV)

ANTENNA POLARITY & TEST DISTANCE: HORIZONTAL AT 3 M										
FREQ. (MHz)	EMISSION LEVEL (dBuV/m)	READ LEVEL (dBuV)	LIMIT (dBuV/m)	MARGIN (dB)	ANTENNA FACTOR (dB /m)	CABLE LOSS (dB)	PREAMP FACTOR (dB)	ANTENNA HEIGHT (cm)	TABLE ANGLE (Degree)	REMARK
5150	54.09	56.4	74	-19.91	34.52	9.52	46.35	103	345	Peak
5150	48.87	51.18	54	-5.13	34.52	9.52	46.35	103	345	Average
5180	88.16	90.39	-	-	34.54	9.58	46.35	103	345	Peak
5180	80.83	83.06	-	-	34.54	9.58	46.35	103	345	Average
5350	55.26	56.94	74	-18.74	34.68	9.94	46.3	103	345	Peak
5350	48.51	50.19	54	-5.49	34.68	9.94	46.3	103	345	Average

ANTENNA POLARITY & TEST DISTANCE: VERTICAL AT 3 M										
FREQ. (MHz)	EMISSION LEVEL (dBuV/m)	READ LEVEL (dBuV)	LIMIT (dBuV/m)	MARGIN (dB)	ANTENNA FACTOR (dB /m)	CABLE LOSS (dB)	PREAMP FACTOR (dB)	ANTENNA HEIGHT (cm)	TABLE ANGLE (Degree)	REMARK
5150	55.31	57.54	74	-18.69	34.6	9.52	46.35	105	93	Peak
5150	49.26	51.49	54	-4.74	34.6	9.52	46.35	105	93	Average
5180	91.16	93.33	-	-	34.6	9.58	46.35	105	93	Peak
5180	83.57	85.74	-	-	34.6	9.58	46.35	105	93	Average
5350	54.97	56.73	74	-19.03	34.6	9.94	46.3	105	93	Peak
5350	47.43	49.19	54	-6.57	34.6	9.94	46.3	105	93	Average

REMARKS:

- Emission Level = Read Level+ Antenna Factor + Cable Loss- Preamp Factor
Margin value = Emission level – Limit value.
- 5180MHz: Fundamental frequency.



CHANNEL	TX Channel 40	DETECTOR FUNCTION	Peak (PK)
FREQUENCY RANGE	1GHz ~ 40GHz		Average (AV)

ANTENNA POLARITY & TEST DISTANCE: HORIZONTAL AT 3 M

FREQ. (MHz)	EMISSION LEVEL (dBuV/m)	READ LEVEL (dBuV)	LIMIT (dBuV/m)	MARGIN (dB)	ANTENNA FACTOR (dB /m)	CABLE LOSS (dB)	PREAMP FACTOR (dB)	ANTENNA HEIGHT (cm)	TABLE ANGLE (Degree)	REMARK
5150	55.35	57.66	74	-18.65	34.52	9.52	46.35	103	345	Peak
5150	48.21	50.52	54	-5.79	34.52	9.52	46.35	103	345	Average
5200	89.14	91.3	-	-	34.56	9.62	46.34	103	345	Peak
5200	81.96	84.12	-	-	34.56	9.62	46.34	103	345	Average
5350	53.33	55.01	74	-20.67	34.68	9.94	46.3	103	345	Peak
5350	48.09	49.77	54	-5.91	34.68	9.94	46.3	103	345	Average

ANTENNA POLARITY & TEST DISTANCE: VERTICAL AT 3 M

FREQ. (MHz)	EMISSION LEVEL (dBuV/m)	READ LEVEL (dBuV)	LIMIT (dBuV/m)	MARGIN (dB)	ANTENNA FACTOR (dB /m)	CABLE LOSS (dB)	PREAMP FACTOR (dB)	ANTENNA HEIGHT (cm)	TABLE ANGLE (Degree)	REMARK
5150	54.17	56.4	74	-19.83	34.6	9.52	46.35	103	93	Peak
5150	48.77	51	54	-5.23	34.6	9.52	46.35	103	93	Average
5200	92.29	94.41	-	-	34.6	9.62	46.34	103	93	Peak
5200	85.25	87.37	-	-	34.6	9.62	46.34	103	93	Average
5350	53.41	55.17	74	-20.59	34.6	9.94	46.3	103	93	Peak
5350	48.6	50.36	54	-5.4	34.6	9.94	46.3	103	93	Average

REMARKS:

1. Emission Level = Read Level+ Antenna Factor + Cable Loss- Preamp Factor
Margin value = Emission level – Limit value.
2. 5200MHz: Fundamental frequency.



CHANNEL	TX Channel 48	DETECTOR FUNCTION	Peak (PK)
FREQUENCY RANGE	1GHz ~ 40GHz		Average (AV)

ANTENNA POLARITY & TEST DISTANCE: HORIZONTAL AT 3 M

FREQ. (MHz)	EMISSION LEVEL (dBuV/m)	READ LEVEL (dBuV)	LIMIT (dBuV/m)	MARGIN (dB)	ANTENNA FACTOR (dB /m)	CABLE LOSS (dB)	PREAMP FACTOR (dB)	ANTENNA HEIGHT (cm)	TABLE ANGLE (Degree)	REMARK
5150	52.75	55.06	74	-21.25	34.52	9.52	46.35	100	345	Peak
5150	48.02	50.33	54	-5.98	34.52	9.52	46.35	100	345	Average
5240	89.94	91.97	-	-	34.59	9.71	46.33	100	345	Peak
5240	83.1	85.13	-	-	34.59	9.71	46.33	100	345	Average
5350	53.59	55.27	74	-20.41	34.68	9.94	46.3	100	345	Peak
5350	48.05	49.73	54	-5.95	34.68	9.94	46.3	100	345	Average

ANTENNA POLARITY & TEST DISTANCE: VERTICAL AT 3 M

FREQ. (MHz)	EMISSION LEVEL (dBuV/m)	READ LEVEL (dBuV)	LIMIT (dBuV/m)	MARGIN (dB)	ANTENNA FACTOR (dB /m)	CABLE LOSS (dB)	PREAMP FACTOR (dB)	ANTENNA HEIGHT (cm)	TABLE ANGLE (Degree)	REMARK
5150	53.84	56.07	74	-20.16	34.6	9.52	46.35	103	93	Peak
5150	48.87	51.1	54	-5.13	34.6	9.52	46.35	103	93	Average
5240	93.72	95.74	-	-	34.6	9.71	46.33	103	93	Peak
5240	86.63	88.65	-	-	34.6	9.71	46.33	103	93	Average
5350	53.31	55.07	74	-20.69	34.6	9.94	46.3	103	93	Peak
5350	47.85	49.61	54	-6.15	34.6	9.94	46.3	103	93	Average

REMARKS:

- Emission Level = Read Level+ Antenna Factor + Cable Loss- Preamp Factor
Margin value = Emission level – Limit value.
- 5240MHz: Fundamental frequency.



802.11ac (40MHz)

CHANNEL	TX Channel 38	DETECTOR FUNCTION	Peak (PK)
FREQUENCY RANGE	1GHz ~ 40GHz		Average (AV)

ANTENNA POLARITY & TEST DISTANCE: HORIZONTAL AT 3 M										
FREQ. (MHz)	EMISSION LEVEL (dBuV/m)	READ LEVEL (dBuV)	LIMIT (dBuV/m)	MARGIN (dB)	ANTENNA FACTOR (dB /m)	CABLE LOSS (dB)	PREAMP FACTOR (dB)	ANTENNA HEIGHT (cm)	TABLE ANGLE (Degree)	REMARK
5150	56.06	58.37	74	-17.94	34.52	9.52	46.35	100	345	Peak
5150	49.53	51.84	54	-4.47	34.52	9.52	46.35	100	345	Average
5190	82.24	84.43	-	-	34.55	9.6	46.34	100	345	Peak
5190	75.02	77.21	-	-	34.55	9.6	46.34	100	345	Average
5350	53.32	55	74	-20.68	34.68	9.94	46.3	100	345	Peak
5350	47.66	49.34	54	-6.34	34.68	9.94	46.3	100	345	Average

ANTENNA POLARITY & TEST DISTANCE: VERTICAL AT 3 M										
FREQ. (MHz)	EMISSION LEVEL (dBuV/m)	READ LEVEL (dBuV)	LIMIT (dBuV/m)	MARGIN (dB)	ANTENNA FACTOR (dB /m)	CABLE LOSS (dB)	PREAMP FACTOR (dB)	ANTENNA HEIGHT (cm)	TABLE ANGLE (Degree)	REMARK
5150	54.94	57.17	74	-19.06	34.6	9.52	46.35	103	93	Peak
5150	50.37	52.6	54	-3.63	34.6	9.52	46.35	103	93	Average
5190	85.73	87.87	-	-	34.6	9.6	46.34	103	93	Peak
5190	79.49	81.63	-	-	34.6	9.6	46.34	103	93	Average
5350	53.28	55.04	74	-20.72	34.6	9.94	46.3	103	93	Peak
5350	47.28	49.04	54	-6.72	34.6	9.94	46.3	103	93	Average

REMARKS:

- Emission Level = Read Level+ Antenna Factor + Cable Loss- Preamp Factor
Margin value = Emission level – Limit value.
- 5190MHz: Fundamental frequency.



CHANNEL	TX Channel 46	DETECTOR FUNCTION	Peak (PK)
FREQUENCY RANGE	1GHz ~ 40GHz		Average (AV)

ANTENNA POLARITY & TEST DISTANCE: HORIZONTAL AT 3 M

FREQ. (MHz)	EMISSION LEVEL (dBuV/m)	READ LEVEL (dBuV)	LIMIT (dBuV/m)	MARGIN (dB)	ANTENNA FACTOR (dB /m)	CABLE LOSS (dB)	PREAMP FACTOR (dB)	ANTENNA HEIGHT (cm)	TABLE ANGLE (Degree)	REMARK
5150	55.15	57.46	74	-18.85	34.52	9.52	46.35	100	345	Peak
5150	49.01	51.32	54	-4.99	34.52	9.52	46.35	100	345	Average
5230	85.61	87.67	-	-	34.58	9.69	46.33	100	345	Peak
5230	79.74	81.8	-	-	34.58	9.69	46.33	100	345	Average
5350	52.97	54.65	74	-21.03	34.68	9.94	46.3	100	345	Peak
5350	47.73	49.41	54	-6.27	34.68	9.94	46.3	100	345	Average

ANTENNA POLARITY & TEST DISTANCE: VERTICAL AT 3 M

FREQ. (MHz)	EMISSION LEVEL (dBuV/m)	READ LEVEL (dBuV)	LIMIT (dBuV/m)	MARGIN (dB)	ANTENNA FACTOR (dB /m)	CABLE LOSS (dB)	PREAMP FACTOR (dB)	ANTENNA HEIGHT (cm)	TABLE ANGLE (Degree)	REMARK
5150	54.15	56.38	74	-19.85	34.6	9.52	46.35	103	93	Peak
5150	49.82	52.05	54	-4.18	34.6	9.52	46.35	103	93	Average
5230	89.49	91.53	-	-	34.6	9.69	46.33	103	93	Peak
5230	83.53	85.57	-	-	34.6	9.69	46.33	103	93	Average
5350	54.32	56.08	74	-19.68	34.6	9.94	46.3	103	93	Peak
5350	47.55	49.31	54	-6.45	34.6	9.94	46.3	103	93	Average

REMARKS:

- Emission Level = Read Level+ Antenna Factor + Cable Loss- Preamp Factor
Margin value = Emission level – Limit value.
- 5230MHz: Fundamental frequency.



802.11ac (80MHz)

CHANNEL	TX Channel 42	DETECTOR FUNCTION	Peak (PK)
FREQUENCY RANGE	1GHz ~ 40GHz		Average (AV)

ANTENNA POLARITY & TEST DISTANCE: HORIZONTAL AT 3 M

FREQ. (MHz)	EMISSION LEVEL (dBuV/m)	READ LEVEL (dBuV)	LIMIT (dBuV/m)	MARGIN (dB)	ANTENNA FACTOR (dB /m)	CABLE LOSS (dB)	PREAMP FACTOR (dB)	ANTENNA HEIGHT (cm)	TABLE ANGLE (Degree)	REMARK
5150	53.64	55.95	74	-20.36	34.52	9.52	46.35	100	345	Peak
5150	49.01	51.32	54	-4.99	34.52	9.52	46.35	100	345	Average
5210	80.38	82.51	-	-	34.57	9.64	46.34	100	345	Peak
5210	72.17	74.3	-	-	34.57	9.64	46.34	100	345	Average
5350	52.93	54.61	74	-21.07	34.68	9.94	46.3	100	345	Peak
5350	47.83	49.51	54	-6.17	34.68	9.94	46.3	100	345	Average

ANTENNA POLARITY & TEST DISTANCE: VERTICAL AT 3 M

FREQ. (MHz)	EMISSION LEVEL (dBuV/m)	READ LEVEL (dBuV)	LIMIT (dBuV/m)	MARGIN (dB)	ANTENNA FACTOR (dB /m)	CABLE LOSS (dB)	PREAMP FACTOR (dB)	ANTENNA HEIGHT (cm)	TABLE ANGLE (Degree)	REMARK
5150	54.15	56.38	74	-19.85	34.6	9.52	46.35	103	93	Peak
5150	50.3	52.53	54	-3.7	34.6	9.52	46.35	103	93	Average
5210	83.28	85.38	-	-	34.6	9.64	46.34	103	93	Peak
5210	76.55	78.65	-	-	34.6	9.64	46.34	103	93	Average
5350	53.48	55.24	74	-20.52	34.6	9.94	46.3	103	93	Peak
5350	48.19	49.95	54	-5.81	34.6	9.94	46.3	103	93	Average

REMARKS:

- Emission Level = Read Level+ Antenna Factor + Cable Loss- Preamp Factor
Margin value = Emission level – Limit value.
- 5210MHz: Fundamental frequency.



3.2 OUT OF BAND EMISSION MEASUREMENT

3.2.1 LIMITS OF OUT OF BAND EMISSION MEASUREMENT

OUT OF THE RESTRICTED BANDS	APPLICABLE TO	EIRP LIMIT (dBm/MHz)
	15.407(b)(1)	-27
	15.407(b)(2)	
	15.407(b)(3)	
	15.407(b)(4)	See note

NOTE:

(b) Undesirable emission limits. Except as shown in paragraph (b)(7) of this section, the maximum emissions outside of the frequency bands of operation shall be attenuated in accordance with the following limits:

(1) For transmitters operating in the 5.15-5.25 GHz band: All emissions outside of the 5.15-5.35 GHz band shall not exceed an e.i.r.p. of -27 dBm/MHz.

(2) For transmitters operating in the 5.25-5.35 GHz band: All emissions outside of the 5.15-5.35 GHz band shall not exceed an e.i.r.p. of -27 dBm/MHz.

(3) For transmitters operating in the 5.47-5.725 GHz band: All emissions outside of the 5.47-5.725 GHz band shall not exceed an e.i.r.p. of -27 dBm/MHz.

(4) For transmitters operating in the 5.725-5.85 GHz band:

(i) All emissions shall be limited to a level of -27 dBm/MHz at 75 MHz or more above or below the band edge increasing linearly to 10 dBm/MHz at 25 MHz above or below the band edge, and from 25 MHz above or below the band edge increasing linearly to a level of 15.6 dBm/MHz at 5 MHz above or below the band edge, and from 5 MHz above or below the band edge increasing linearly to a level of 27 dBm/MHz at the band edge.



3.2.2 TEST INSTRUMENTS

Equipment	Manufacturer	Model No.	Serial No.	Last Cal.	Next Cal.
10dB Attenuator	JFW/USA	50HF-010-SMA	1505	Jun. 03,21	Jun. 02,22
EXA Signal Analyzer	KEYSIGHT	N9010A-544	MY54510355	Jun. 03,21	Jun. 02,22

NOTE:

1. The calibration interval of the above test instruments is 12 months and the calibrations are traceable to CEPREI/CHINA, GRGT/CHINA and NIM/CHINA.
2. The test was performed in RF OVEN ROOM.
3. The FCC Site Registration No. is 525120; The Designation No. is CN1171.

3.2.3 TEST PROCEDURES

- a. Check the calibration of the measurement instrument using either an internal calibrator or a known signal from an external generator.
- b. The resolution bandwidth is set to 1MHzThe Video bandwidth is set to ≥1MHz, report the peak value out of oprating band.
- c. Repeat above procedures until all frequencies measured wre complete.

NOTE: All modes of operation were investigated and the worst-case emissions are reported,antenna gain was added into the test result.

3.2.4 DEVIATION FROM TEST STANDARD

No deviation.

3.2.5 TEST SETUP

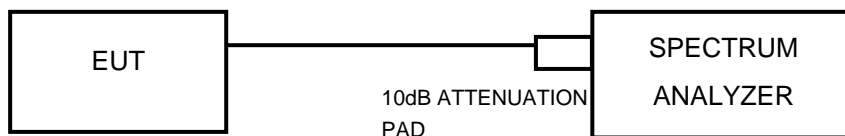

3.2.6 EUT OPERATING CONDITION

- a. Set the EUT under full load condition and placed them on a testing table.
- b. Set the transmitter part of EUT under transmission condition continuously at specific channel frequency.
- c. The necessary accessories enable the EUT in full functions.



3.2.7 TEST RESULTS

For U-NII-1:

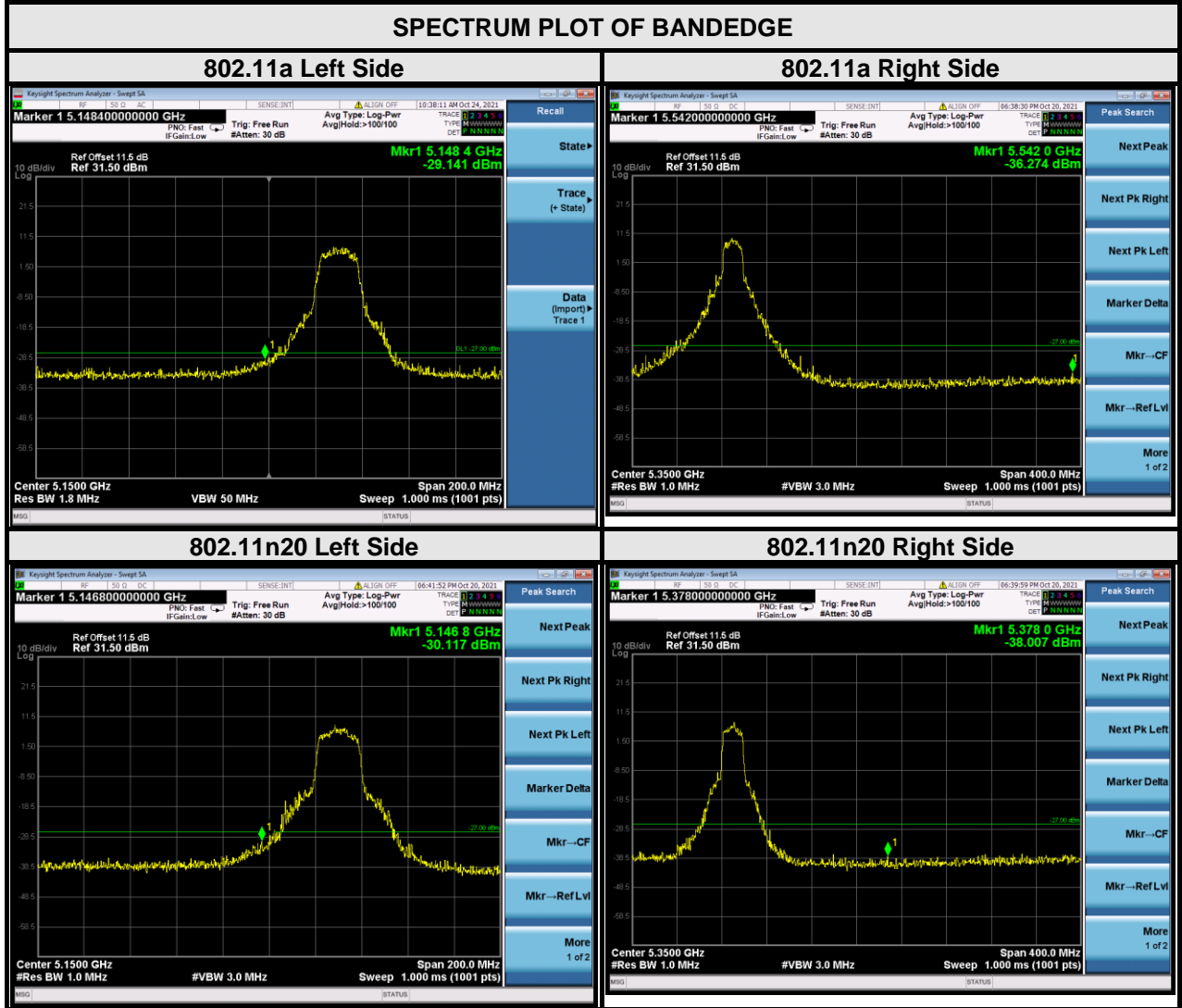

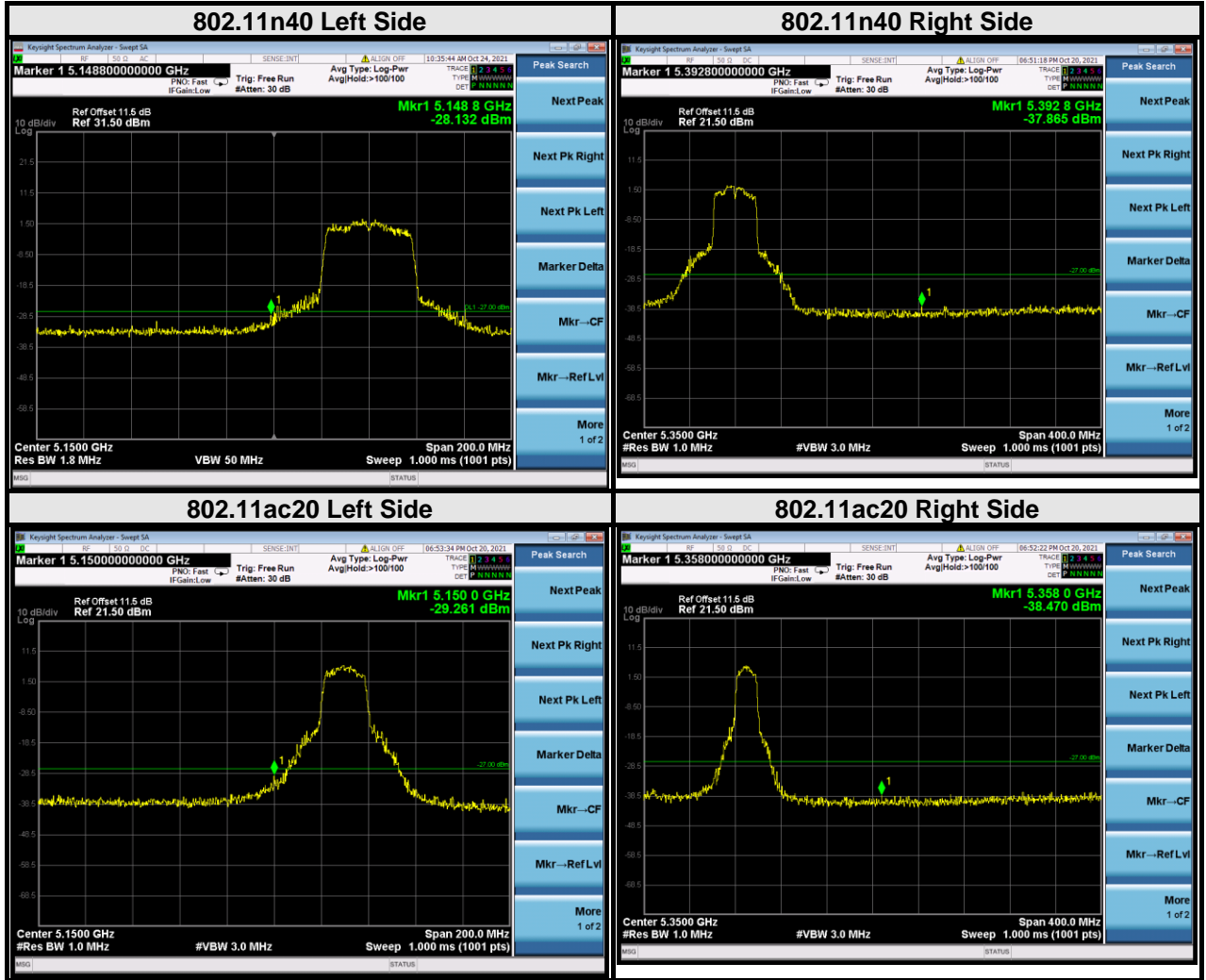

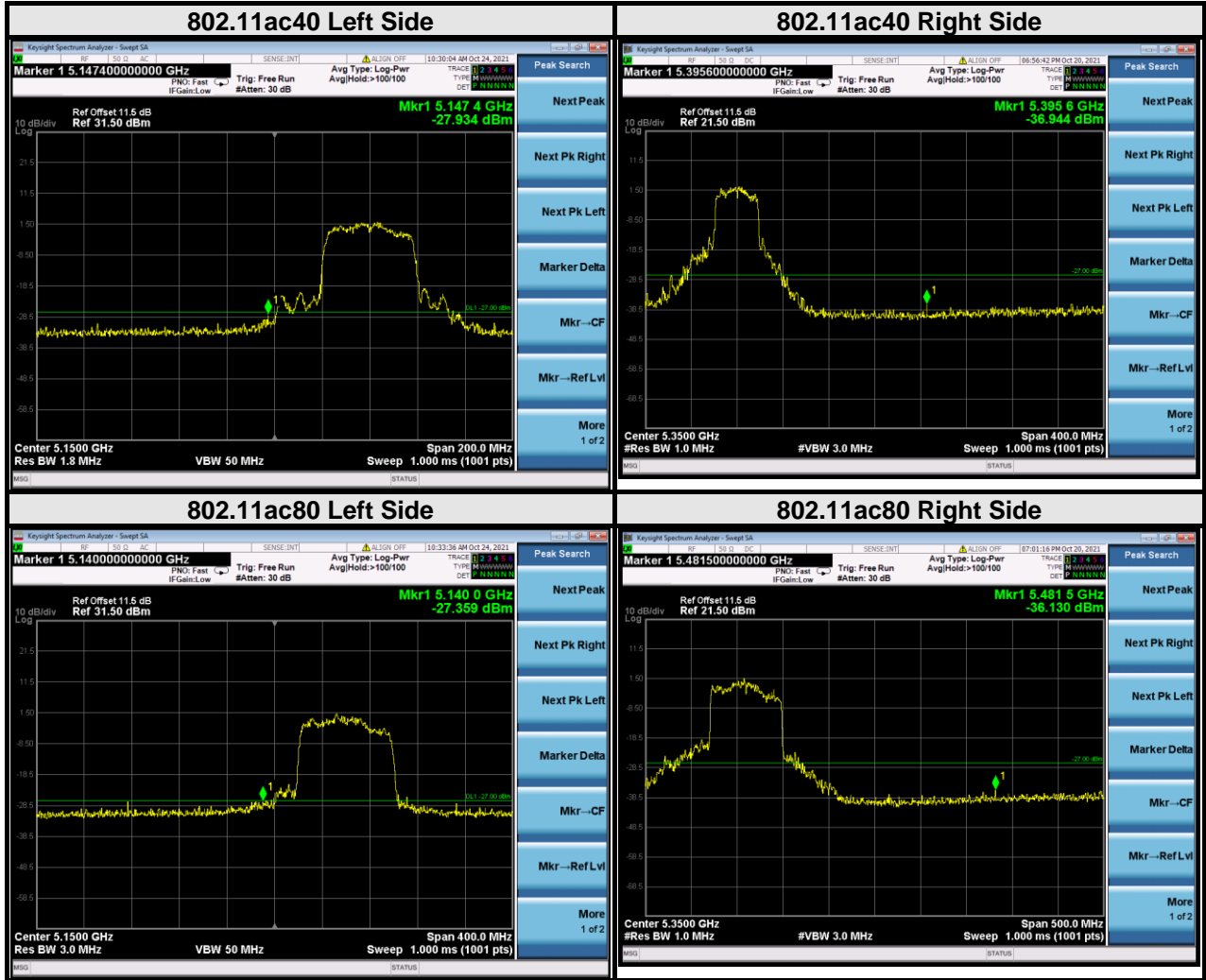



3.3 CONDUCTED EMISSION MEASUREMENT

3.3.1 LIMITS OF CONDUCTED EMISSION MEASUREMENT

FREQUENCY OF EMISSION (MHz)	CONDUCTED LIMIT (dBµV)	
	Quasi-peak	Average
0.15 ~ 0.5	66 to 56	56 to 46
0.5 ~ 5	56	46
5 ~ 30	60	50

- NOTE:**
1. The lower limit shall apply at the transition frequencies.
 2. The limit decreases in line with the logarithm of the frequency in the range of 0.15 to 0.50MHz.
 3. All emanations from a class A/B digital device or system, including any network of conductors and apparatus connected thereto, shall not exceed the level of field strengths specified above.

3.3.2 TEST INSTRUMENTS

Equipment	Manufacturer	Model No.	Serial No.	Last Cal.	Next Cal.
EMI Test Receiver	Rohde&Schwarz	ESR3	101900	Mar. 03,21	Mar. 02,22
EMC32 test software	Rohde&Schwarz	EMC32	NA	NA	NA
LISN network	Rohde&Schwarz	ENV216	101922	Feb. 22,21	Feb. 21,22

- NOTE:**
1. The test was performed in CE shielded room.
 2. The calibration interval of the above test instruments is 12 months. And the calibrations are traceable to CEPREI/CHINA, GRGT/CHINA and NIM/CHINA.

3.3.3 TEST PROCEDURES

- a. The EUT was placed 0.4 meters from the conducting wall of the shielded room with EUT being connected to the power mains through a line impedance stabilization network (LISN). Other support units were connected to the power mains through another LISN. The two LISNs provide 50 ohm/ 50uH of coupling impedance for the measuring instrument.
- b. Both lines of the power mains connected to the EUT were checked for maximum conducted interference.
- c. The frequency range from 150kHz to 30MHz was searched. Emission levels under (Limit - 20dB) was not recorded.

NOTE: All modes of operation were investigated and the worst-case emissions are reported.



3.3.4 DEVIATION FROM TEST STANDARD

No deviation.

3.3.5 TEST SETUP

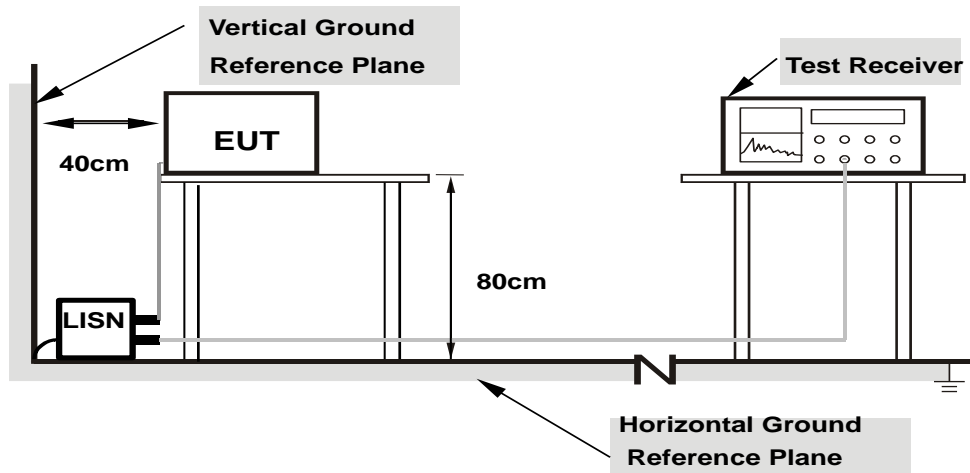

- Note:**
- 1.Support units were connected to second LISN.
 - 2.Both of LISNs (AMN) are 80 cm from EUT and at least 80 from other units and other metal planes

For the actual test configuration, please refer to the attached file (Test Setup Photo).

3.3.6 EUT OPERATING CONDITIONS

Same as 3.1.6.



3.3.7 TEST RESULTS

CONDUCTED WORST-CASE DATA:

Frequency Range	150KHz ~ 30MHz	Detector Function & Resolution Bandwidth	Quasi-Peak (QP) / Average (AV), 9 kHz
Input Power	120Vac, 60Hz	Environmental Conditions	24deg. C, 55%RH
Tested By	Carl Xie		

Frequency (MHz)	QuasiPeak (dBuV)	CAverage (dBuV)	Limit (dBuV)	Margin (dB)	Line	Filter	Corr. (dB)
0.154000	---	27.58	55.78	28.20	L1	ON	9.7
0.154000	41.07	---	65.78	24.71	L1	ON	9.7
0.384000	---	34.14	48.19	14.05	L1	ON	9.7
0.384000	39.36	---	58.19	18.83	L1	ON	9.7
1.472000	---	18.88	46.00	27.12	L1	ON	9.7
1.472000	22.68	---	56.00	33.32	L1	ON	9.7
3.368000	---	11.57	46.00	34.43	L1	ON	9.7
3.368000	23.35	---	56.00	32.65	L1	ON	9.7
10.924000	---	36.12	50.00	13.88	L1	ON	9.8
10.924000	41.47	---	60.00	18.53	L1	ON	9.8
18.944000	---	22.07	50.00	27.93	L1	ON	9.8
18.944000	26.99	---	60.00	33.01	L1	ON	9.8

- REMARKS:**
1. Q.P. and AV. are abbreviations of quasi-peak and average individually.
 2. "-": The Quasi-peak reading value also meets average limit and measurement with the average detector is unnecessary.
 3. The emission levels of other frequencies were very low against the limit.
 4. Margin value = Limit value - Emission level
 5. Correction factor = Insertion loss + Cable loss
 6. Emission Level = Correction Factor + Reading Value.

Full Spectrum

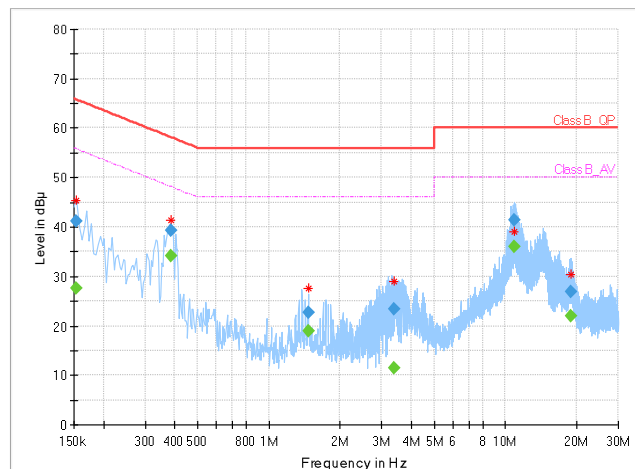



Frequency Range	150KHz ~ 30MHz	Detector Function & Resolution Bandwidth	Quasi-Peak (QP) / Average (AV), 9 kHz
Input Power	120Vac, 60Hz	Environmental Conditions	24deg. C, 55%RH
Tested By	Carl Xie		

Frequency (MHz)	QuasiPeak (dBuV)	CAverage (dBuV)	Limit (dBuV)	Margin (dB)	Line	Filter	Corr. (dB)																																																															
0.158000	---	25.37	55.57	30.20	N	ON	9.7																																																															
0.158000	38.46	---	65.57	27.11	N	ON	9.7																																																															
0.384000	---	31.79	48.19	16.40	N	ON	9.7																																																															
0.384000	37.08	---	58.19	21.11	N	ON </tr <tr> <td>1.472000</td> <td>---</td> <td>20.70</td> <td>46.00</td> <td>25.30</td> <td>N</td> <td>ON</td> <td>9.8</td> </tr> <tr> <td>1.472000</td> <td>23.74</td> <td>---</td> <td>56.00</td> <td>32.26</td> <td>N</td> <td>ON</td> <td>9.8</td> </tr> <tr> <td>3.484000</td> <td>---</td> <td>16.88</td> <td>46.00</td> <td>29.12</td> <td>N</td> <td>ON</td> <td>9.8</td> </tr> <tr> <td>3.484000</td> <td>25.56</td> <td>---</td> <td>56.00</td> <td>30.44</td> <td>N</td> <td>ON</td> <td>9.8</td> </tr> <tr> <td>10.892000</td> <td>---</td> <td>38.21</td> <td>50.00</td> <td>11.79</td> <td>N</td> <td>ON</td> <td>9.8</td> </tr> <tr> <td>10.892000</td> <td>43.13</td> <td>---</td> <td>60.00</td> <td>16.87</td> <td>N</td> <td>ON</td> <td>9.8</td> </tr> <tr> <td>14.596000</td> <td>---</td> <td>26.96</td> <td>50.00</td> <td>23.04</td> <td>N</td> <td>ON</td> <td>9.8</td> </tr> <tr> <td>14.596000</td> <td>33.62</td> <td>---</td> <td>60.00</td> <td>26.38</td> <td>N</td> <td>ON</td> <td>9.8</td> </tr>	1.472000	---	20.70	46.00	25.30	N	ON	9.8	1.472000	23.74	---	56.00	32.26	N	ON	9.8	3.484000	---	16.88	46.00	29.12	N	ON	9.8	3.484000	25.56	---	56.00	30.44	N	ON	9.8	10.892000	---	38.21	50.00	11.79	N	ON	9.8	10.892000	43.13	---	60.00	16.87	N	ON	9.8	14.596000	---	26.96	50.00	23.04	N	ON	9.8	14.596000	33.62	---	60.00	26.38	N	ON	9.8
1.472000	---	20.70	46.00	25.30	N	ON	9.8																																																															
1.472000	23.74	---	56.00	32.26	N	ON	9.8																																																															
3.484000	---	16.88	46.00	29.12	N	ON	9.8																																																															
3.484000	25.56	---	56.00	30.44	N	ON	9.8																																																															
10.892000	---	38.21	50.00	11.79	N	ON	9.8																																																															
10.892000	43.13	---	60.00	16.87	N	ON	9.8																																																															
14.596000	---	26.96	50.00	23.04	N	ON	9.8																																																															
14.596000	33.62	---	60.00	26.38	N	ON	9.8																																																															

- REMARKS:**
1. Q.P. and AV. are abbreviations of quasi-peak and average individually.
 2. "-": The Quasi-peak reading value also meets average limit and measurement with the average detector is unnecessary.
 3. The emission levels of other frequencies were very low against the limit.
 4. Margin value = Limit value - Emission level
 5. Correction factor = Insertion loss + Cable loss
 6. Emission Level = Correction Factor + Reading Value.

Full Spectrum

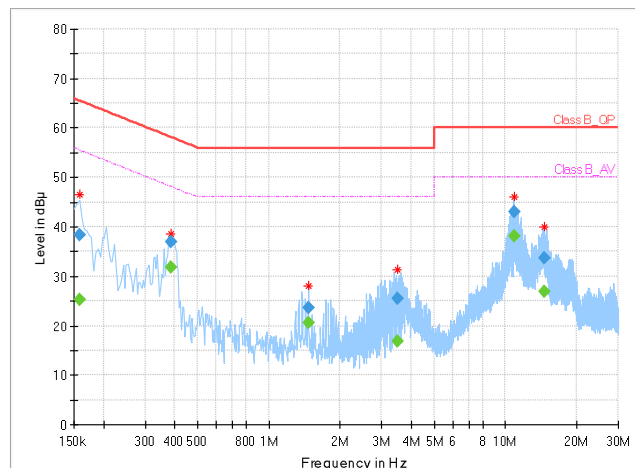



3.4 MAXIMUM CONDUCTED OUTPUT POWER MEASUREMENT

3.4.1 LIMITS OF MAXIMUM CONDUCTED OUTPUT POWER MEASUREMENT

Operation Band	EUT Category		LIMIT
U-NII-1		Outdoor Access Point	1 Watt (30 dBm) (Max. e.i.r.p ≤ 125mW(21 dBm) at any elevation angle above 30 degrees as measured from the horizon)
		Fixed point-to-point Access Point	1 Watt (30 dBm)
	B	Indoor Access Point	1 Watt (30 dBm)
	√	Client devices	250mW (24 dBm)
U-NII-2A	√		250mW (24 dBm) or 11 dBm+10 log B*
U-NII-2C	√		250mW (24 dBm) or 11 dBm+10 log B*
U-NII-3	√		1 Watt (30 dBm)

NOTE: Where B is the 26dB emission bandwidth in MHz.



3.4.2 TEST SETUP

FOR POWER OUTPUT MEASUREMENT

802.11a, 802.11n (20MHz), 802.11n (40MHz) TEST CONFIGURATION

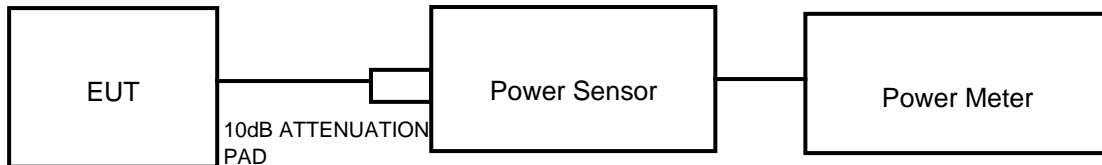

11ac TEST CONFIGURATION

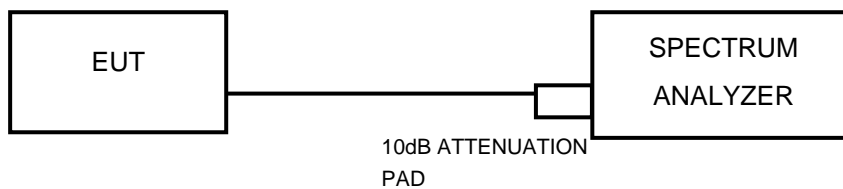

FOR 26dB BANDWIDTH

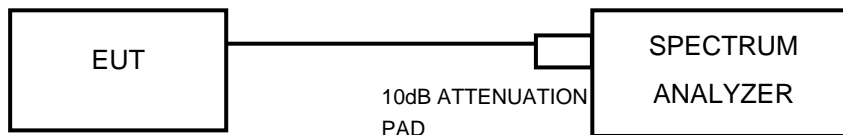

3.4.3 TEST INSTRUMENTS

Equipment	Manufacturer	Model No.	Serial No.	Last Cal.	Next Cal.
Power Meter	ANRITSU	ML2495A	1506002	Feb. 22,21	Feb. 21,22
EXA Signal Analyzer	KEYSIGHT	N9010A-526	MY54510322	Feb. 25,21	Feb. 24,22
EXA Signal Analyzer	KEYSIGHT	N9010A-544	MY54510355	Jun. 03,21	Jun. 02,22
Power Sensor	ANRITSU	MA2411B	1339352	May. 07,21	May. 08,22

NOTE:

1. The calibration interval of the above test instruments is 12 months and the calibrations are traceable to CEPREI/CHINA, GRGT/CHINA and NIM/CHINA.
2. The test was performed in RF Oven room.



3.4.4 TEST PROCEDURE

FOR POWER MEASUREMENT

For 802.11a, 802.11n (20MHz), 802.11n (40MHz)

Method PM is used to perform output power measurement, trigger and gating function of wide band power meter is enabled to measure max output power of TX on burst. Duty factor is not added to measured value.

For 802.11ac (80MHz)

1. Measure the duty cycle, x , of the transmitter output signal as described in II.B.
2. Set span to encompass the EBW (or, alternatively, the entire 99% occupied bandwidth) of the signal.
3. Set RBW = 1 MHz.
4. Set VBW \geq 3 MHz.
5. Number of points in sweep $\geq 2 \times \text{span} / \text{RBW}$. (This ensures that bin-to-bin spacing is $\leq \text{RBW}/2$, so that narrowband signals are not lost between frequency bins.)
6. Sweep time = auto.
7. Detector = power averaging (rms), if available. Otherwise, use sample detector mode.
8. Do not use sweep triggering. Allow the sweep to “free run.”
9. Trace average at least 100 traces in power averaging (rms) mode; however, the number of traces to be averaged shall be increased above 100 as needed to ensure that the average accurately represents the true average over the on and off periods of the transmitter.
10. Add $10 \log (1/x)$, where x is the duty cycle, to the measured power to compute the average power during the actual transmission times (because the measurement represents an average over both the on and off times of the transmission). For example, add $10 \log (1/0.25) = 6 \text{ dB}$ if the duty cycle is 25%.



FOR 99 PERCENT OCCUPIED BANDWIDTH

The following procedure shall be used for measuring (99 %) power bandwidth:

1. Set center frequency to the nominal EUT channel center frequency.
2. Set span = 1.5 times to 5.0 times the OBW.
3. Set RBW = 1 % to 5 % of the OBW
4. Set VBW $\geq 3 \cdot$ RBW
5. Video averaging is not permitted. Where practical, a sample detection and single sweep mode shall be used. Otherwise, peak detection and max hold mode (until the trace stabilizes) shall be used.
6. Use the 99 % power bandwidth function of the instrument (if available).
7. If the instrument does not have a 99 % power bandwidth function, the trace data points are recovered and directly summed in power units. The recovered amplitude data points, beginning at the lowest frequency, are placed in a running sum until 0.5 % of the total is reached; that frequency is recorded as the lower frequency. The process is repeated until 99.5 % of the total is reached; that frequency is recorded as the upper frequency. The 99% occupied bandwidth is the difference between these two frequencies.

FOR 26dB BANDWIDTH

- 1) Set RBW = approximately 1% of the emission bandwidth.
- 2) Set the VBW > RBW.
- 3) Detector = Peak.
- 4) Trace mode = max hold.
- 5) Measure the maximum width of the emission that is 26 dB down from the peak of the emission. Compare this with the RBW setting of the analyzer. Readjust RBW and repeat measurement as needed until the RBW/EBW ratio is approximately 1%.

FOR 6dB BANDWIDTH

1. Set RBW = 100 kHz.
2. Set the video bandwidth (VBW) ≥ 3 RBW.
3. Detector = Peak.
4. Trace mode = max hold.
5. Sweep = auto couple.
6. Allow the trace to stabilize.
7. Measure the maximum width of the emission that is constrained by the frequencies associated with the two outermost amplitude points (upper and lower frequencies) that are attenuated by 6 dB relative to the maximum level measured in the fundamental emission.



Test Report No.: W7L-P21100003RF03

3.4.5 DEVIATION FROM TEST STANDARD

No deviation.

3.4.6 EUT OPERATING CONDITIONS

The software provided by client to enable the EUT under transmission condition continuously at specific channel frequencies individually.



BUREAU VERITAS Test Report No.: W7L-P21100003RF03

3.4.7 TEST RESULTS

OUTPUT POWER:

Please Refer to Appendix A 3 Of this test report.

99% OCCUPIED BANDWIDTH & 26dB BANDWIDTH

Please Refer to Appendix A 3 Of this test report.



3.5 MAXIMUM POWER SPECTRAL DENSITY MEASUREMENT

3.5.1 LIMITS OF MAXIMUM POWER SPECTRAL DENSITY MEASUREMENT

Operation Band	EUT Category		LIMIT
U-NII-1		Outdoor Access Point	17dBm/ MHz
		Fixed point-to-point Access Point	
		Indoor Access Point	
	√	Client devices	11dBm/ MHz
U-NII-2A	√		11dBm/ MHz
U-NII-2C	√		11dBm/ MHz
U-NII-3	√		30dBm/ 500kHz

3.5.2 TEST SETUP

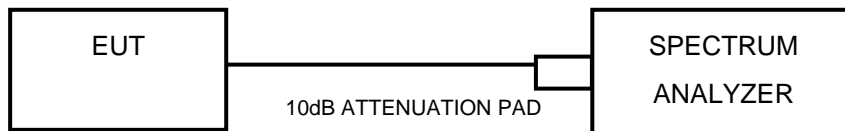

3.5.3 TEST INSTRUMENTS

Refer to section 3.3.3 to get information of above instrument.



3.5.4 TEST PROCEDURES

Using method SA-2

- 1) Set span to encompass the entire emission bandwidth (EBW) of the signal.
- 2) Set RBW = 1 MHz, Set VBW \geq 3 MHz, Detector = RMS
- 3) Set Channel power measure = 1MHz
- 4) Sweep time = auto, trigger set to "free run".
- 5) Trace average at least 100 traces in power averaging mode.
- 6) Add $10 \log(1/x)$, where x is the duty cycle, to the measured power in order to compute the average power during the actual transmission times (because the measurement represents an average over both the on and off times of the transmission).
- 7) Record the max value

3.5.5 DEVIATION FROM TEST STANDARD

No deviation.

3.5.6 EUT OPERATING CONDITIONS

Same as 3.1.6.



Test Report No.: W7L-P21100003RF03

3.5.7 TEST RESULTS

Please Refer to Appendix A 3 Of this test report.



Test Report No.: W7L-P21100003RF03

4 PHOTOGRAPHS OF THE TEST CONFIGURATION

Please refer to the attached file (Test Setup Photo).



Test Report No.: W7L-P21100003RF03

5 APPENDIX A – MODIFICATIONS RECORDERS FOR ENGINEERING CHANGES TO THE EUT BY THE LAB

No modifications were made to the EUT by the lab during the test.

---END---