

FCC TEST REPORT

(Part 15, Subpart E)

Applicant:	PAX Technology Limited
Address:	Room 2416, 24/F., Sun Hung Kai Centre, 30 Harbour Road, Wanchai, Hong Kong

Manufacturer or Supplier:	PAX Computer Technology (Shenzhen) Co., Ltd.
Address:	4/F, No.3 Building, Software Park, Second Central Science-Tech Road, High-Tech industrial Park, Shenzhen, Guangdong, P.R.C.
Product:	Integrated Smart Terminal
Brand Name:	PAX
Model Name:	E700
FCC ID:	V5PE700
Date of tests:	Mar 27, 2019 ~ Jul 17, 2019

The tests have been carried out according to the requirements of the following standard:

FCC Part 15, Subpart E, Section 15.407

CONCLUSION: The submitted sample was found to COMPLY with the test requirement

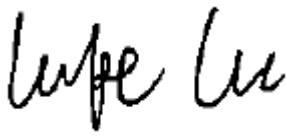
Prepared by Alex Chen Engineer / Mobile Department	Approved by Luke Lu Manager / Mobile Department
 Date: Jul 22, 2019	 Date: Jul 22, 2019

This report is governed by, and incorporates by reference, CPS Conditions of Service as posted at the date of issuance of this report at <http://www.bureauveritas.com/home/about-us/our-business/cps/about-us/terms-conditions> and is intended for your exclusive use. Any copying or replication of this report to or for any other person or entity, or use of our name or trademark, is permitted only with our prior written permission. This report sets forth our findings solely with respect to the test samples identified herein. The results set forth in this report are not indicative or representative of the quality or characteristics of the lot from which a test sample was taken or any similar or identical product unless specifically and expressly noted. Our report includes all of the tests requested by you and the results thereof based upon the information that you provided to us. Measurement uncertainty is only provided upon request for accredited tests. You have 60 days from date of issuance of this report to notify us of any material error or omission caused by our negligence or if you require measurement uncertainty; provided, however, that such notice shall be in writing and shall specifically address the issue you wish to raise. A failure to raise such issue within the prescribed time shall constitute your unqualified acceptance of the completeness of this report, the tests conducted and the correctness of the report contents.



TABLE OF CONTENTS

RELEASE CONTROL RECORD 4

1 SUMMARY OF TEST RESULTS..... 5

1.1 MEASUREMENT UNCERTAINTY 5

2 GENERAL INFORMATION 6

2.1 GENERAL DESCRIPTION OF EUT 6

2.2 DESCRIPTION OF TEST MODES 8

2.2.1 TEST MODE APPLICABILITY AND TESTED CHANNEL DETAIL..... 10

2.3 DUTY CYCLE OF TEST SIGNAL 13

2.4 DESCRIPTION OF SUPPORT UNITS 14

2.4.1 CONFIGURATION OF SYSTEM UNDER TEST 14

2.5 GENERAL DESCRIPTION OF APPLIED STANDARDS 15

3 TEST TYPES AND RESULTS..... 16

3.1 RADIATED EMISSION AND BANDEDGE MEASUREMENT 16

3.1.1 LIMITS OF RADIATED EMISSION AND BANDEDGE MEASUREMENT..... 16

3.1.2 LIMITS OF UNWANTED EMISSION 16

3.1.3 TEST INSTRUMENTS 17

3.1.4 TEST PROCEDURES 18

3.1.5 DEVIATION FROM TEST STANDARD 18

3.1.6 TEST SETUP 19

3.1.7 EUT OPERATING CONDITION 20

3.1.8 TEST RESULTS 21

3.2 CONDUCTED EMISSION MEASUREMENT 69

3.2.1 LIMITS OF CONDUCTED EMISSION MEASUREMENT 69

3.2.2 TEST INSTRUMENTS 69

3.2.3 TEST PROCEDURES 69

3.2.4 DEVIATION FROM TEST STANDARD 70

3.2.5 TEST SETUP 70

3.2.6 EUT OPERATING CONDITIONS 70

3.2.7 TEST RESULTS 71

3.3 MAXIMUM CONDUCTED OUTPUT POWER MEASUREMENT 73

3.3.1 LIMITS OF MAXIMUM CONDUCTED OUTPUT POWER MEASUREMENT 73

3.3.2 TEST SETUP 74



3.3.3	TEST INSTRUMENTS.....	74
3.3.4	TEST PROCEDURE.....	75
3.3.5	DEVIATION FROM TEST STANDARD	77
3.3.6	EUT OPERATING CONDITIONS	77
3.3.7	TEST RESULTS	78
3.4	MAXIMUM POWER SPECTRAL DENSITY MEASUREMENT.....	91
3.4.1	LIMITS OF MAXIMUM POWER SPECTRAL DENSITY MEASUREMENT	91
3.4.2	TEST SETUP	91
3.4.3	TEST INSTRUMENTS.....	91
3.4.4	TEST PROCEDURES	92
3.4.5	DEVIATION FROM TEST STANDARD	92
3.4.6	EUT OPERATING CONDITIONS	92
3.4.7	TEST RESULTS	93
3.5	FREQUENCY STABILITY	100
3.5.1	LIMITS OF FREQUENCY STABILITY MEASUREMENT	100
3.5.2	TEST SETUP	100
3.5.3	TEST INSTRUMENTS.....	100
3.5.4	TEST PROCEDURE.....	101
3.5.5	DEVIATION FROM TEST STANDARD	101
3.5.6	EUT OPERATING CONDITION	101
3.5.7	TEST RESULTS	102
4	PHOTOGRAPHS OF THE TEST CONFIGURATION.....	104
5	APPENDIX A – MODIFICATIONS RECORDERS FOR ENGINEERING CHANGES TO THE EUT BY THE LAB.....	105



BUREAU
VERITAS

Test Report No.: RF190326W003-3

RELEASE CONTROL RECORD

ISSUE NO.	REASON FOR CHANGE	DATE ISSUED
RF190326W003-3	Original release	Jul 22, 2019



1 SUMMARY OF TEST RESULTS

The EUT has been tested according to the following specifications:

APPLIED STANDARD: FCC PART 15, SUBPART E (SECTION 15.407)			
STANDARD SECTION	TEST TYPE AND LIMIT	RESULT	REMARK
15.407(b)(5)	AC Power Conducted Emission	PASS	Meet the requirement of limit. Minimum passing margin is -12.33dB at 0.560000MHz.
15.407(b) (1/2/3/4/6)	Radiated Emission & Band Edge Measurement	PASS	Meet the requirement of limit. Minimum passing margin is -3.05dB at 5150MHz.
15.407(a/1/2/3)	Maximum conducted output Power	PASS	Meet the requirement of limit.
15.407(a/1/2/3)	Peak Power Spectral Density	PASS	Meet the requirement of limit.
15.407(e)	6 dB Bandwidth	PASS	Meet the requirement of limit. (U-NII-3 Band only)
15.407(g)	Frequency Stability	PASS	Meet the requirement of limit.
15.203	Antenna Requirement	PASS	No antenna connector is used.

1.1 MEASUREMENT UNCERTAINTY

Where relevant, the following measurement uncertainty levels have been estimated for tests performed on the EUT as specified in CISPR 16-4-2:

MEASUREMENT	UNCERTAINTY
AC Power Conducted emissions	± 2.70dB
All Radiated emissions	±4.48dB
Conducted emissions	±2 dB
Occupied Channel Bandwidth	±21.7KHz
Conducted Output power	±1.03 dB
Power Spectral Density	±0.95 dB

This uncertainty represents an expanded uncertainty expressed at approximately the 95% confidence level using a coverage factor of k = 2.



2 GENERAL INFORMATION

2.1 GENERAL DESCRIPTION OF EUT

EUT	Integrated Smart Terminal
BRAND NAME	PAX
MODEL NAME	E700
POWER SUPPLY	24Vdc (adapter or host equipment) 3.63Vdc (Li-ion, battery)
MODULATION TYPE	64QAM, 16QAM, QPSK, BPSK
MODULATION TECHNOLOGY	OFDM
TRANSFER RATE	802.11a: 54.0/ 48.0/ 36.0/ 24.0/ 18.0/ 12.0/ 9.0/ 6.0Mbps 802.11n: up to MCS7 802.11ac: up to 390.0Mbps
OPERATING FREQUENCY	5180 ~ 5240MHz, 5260 ~ 5320MHz, 5500 ~ 5700MHz, 5745 ~ 5825MHz
NUMBER OF CHANNEL	5180 ~ 5240MHz: 4 for 802.11a, 802.11n (20MHz) 2 for 802.11n (40MHz) 1 for 802.11ac (80MHz) 5260 ~ 5320MHz: 4 for 802.11a, 802.11n (20MHz) 2 for 802.11n (40MHz) 1 for 802.11ac (80MHz) 5500 ~ 5700MHz: 8 for 802.11a, 802.11n (20MHz) 3 for 802.11n (40MHz) 1 for 802.11ac (80MHz) 5745 ~ 5825MHz: 4 for 802.11a, 802.11n (20MHz) 2 for 802.11n (40MHz) 1 for 802.11ac (80MHz)
AVERAGE POWER	26.792mW for 5180 ~ 5240MHz 28.445mW for 5260 ~ 5320MHz 27.733mW for 5500 ~ 5700MHz 17.378mW for 5745 ~ 5825MHz
ANTENNA TYPE	5180 ~ 5240MHz: PIFA Antenna with 1.5dBi gain 5260 ~ 5320MHz: PIFA Antenna with 1.5dBi gain 5500 ~ 5700MHz: PIFA Antenna with 1.5dBi gain 5745 ~ 5825MHz: PIFA Antenna with 1.5dBi gain
HW VERSION	N/A
SW VERSION	N/A
I/O PORTS	Refer to user's manual



CABLE SUPPLIED	Refer to note as below
-----------------------	------------------------

NOTE:

1. For a more detailed features description, please refer to the manufacturer’s specifications or the user's manual.
2. The EUT was powered by the following adapter:

ADAPTER	
BRAND:	HONOTO
MODEL:	ADS-65HI-19A-3 24065E
INPUT:	AC 100-240V, 1.5A
OUTPUT:	DC 24V, 2.7A

3. The EUT incorporates a SISO function. Physically, the EUT provides one completed transmitter and one receiver.

MODULATION MODE	TX FUNCTION
802.11a	1TX/1RX
802.11n (20MHz)	1TX/1RX
802.11n (40MHz)	1TX/1RX
802.11ac (80MHz)	1TX/1RX

4. For the test results, the EUT had been tested with all conditions. But only the worst case was shown in test report.



2.2 DESCRIPTION OF TEST MODES

FOR 5150 ~ 5250MHz

4 channels are provided for 802.11a, 802.11n (20MHz):

CHANNEL	FREQUENCY	CHANNEL	FREQUENCY
36	5180 MHz	44	5220 MHz
40	5200 MHz	48	5240 MHz

2 channels are provided for 802.11n (40MHz):

CHANNEL	FREQUENCY	CHANNEL	FREQUENCY
38	5190 MHz	46	5230 MHz

1 channel is provided for 802.11ac (80MHz):

CHANNEL	FREQUENCY	CHANNEL	FREQUENCY
42	5210 MHz		

FOR 5250 ~ 5350MHz

4 channels are provided for 802.11a, 802.11n (20MHz):

CHANNEL	FREQUENCY	CHANNEL	FREQUENCY
52	5260 MHz	60	5300 MHz
56	5280 MHz	64	5320 MHz

2 channels are provided for 802.11n (40MHz):

CHANNEL	FREQUENCY	CHANNEL	FREQUENCY
54	5270 MHz	62	5310 MHz

1 channel is provided for 802.11ac (80MHz):

CHANNEL	FREQUENCY	CHANNEL	FREQUENCY
58	5290 MHz		



FOR 5470 ~ 5725MHz

8 channels are provided for 802.11a, 802.11n (20MHz):

CHANNEL	FREQUENCY	CHANNEL	FREQUENCY
100	5500 MHz	116	5580 MHz
104	5520 MHz	132	5660 MHz
108	5540 MHz	136	5680 MHz
112	5560 MHz	140	5700 MHz

3 channels are provided for 802.11n (40MHz):

CHANNEL	FREQUENCY	CHANNEL	FREQUENCY
102	5510 MHz	134	5670 MHz
110	5550 MHz		

1 channel is provided for 802.11ac (80MHz):

CHANNEL	FREQUENCY	CHANNEL	FREQUENCY
106	5530 MHz		

FOR 5725 ~ 5825MHz

4 channels are provided for 802.11a, 802.11n (20MHz):

CHANNEL	FREQUENCY	CHANNEL	FREQUENCY
149	5745 MHz	157	5785 MHz
153	5765 MHz	165	5825 MHz

2 channels are provided for 802.11n (40MHz):

CHANNEL	FREQUENCY	CHANNEL	FREQUENCY
151	5755 MHz	159	5795 MHz

1 channel is provided for 802.11ac (80MHz):

CHANNEL	FREQUENCY	CHANNEL	FREQUENCY
155	5775 MHz		



2.2.1 TEST MODE APPLICABILITY AND TESTED CHANNEL DETAIL

EUT CONFIGURE MODE	APPLICABLE TO				DESCRIPTION
	RE≥1G	RE<1G	PLC	APCM	
A	√	√	√	-	Powered by Adapter with wifi(5G) link
B	-	-	-	√	Powered by Battery with wifi(5G) link
C	-	-	-	-	Powered by USB with wifi(5G) link

Where **RE≥1G**: Radiated Emission above 1GHz **RE<1G**: Radiated Emission below 1GHz
PLC: Power Line Conducted Emission **APCM**: Antenna Port Conducted Measurement

NOTE:
The EUT had been pre-tested on the positioned of each 3 axis. The worst case was found when positioned on **X-plane**.
NOTE: "-" means no effect.

RADIATED EMISSION TEST (ABOVE 1GHz):

- Pre-Scan has been conducted to determine the worst-case mode from all possible combinations between available modulations, data rates and antenna ports (if EUT with antenna diversity architecture).
- Following channel(s) was (were) selected for the final test as listed below.

EUT CONFIGURE MODE	MODE	FREQ. BAND (MHz)	AVAILABLE CHANNEL	TESTED CHANNEL	MODULATION TECHNOLOGY	MODULATION TYPE	DATA RATE (Mbps)
A	802.11a	5180-5240	36 to 48	36, 40, 48	OFDM	BPSK	6.0
A	802.11n (20MHz)		36 to 48	36, 40, 48	OFDM	BPSK	MCS0
A	802.11n (40MHz)		38 to 46	38, 46	OFDM	BPSK	MCS0
A	802.11ac (80MHz)		42	42	OFDM	BPSK	V0
A	802.11a	5260-5320	52 to 64	52, 60, 64	OFDM	BPSK	6.0
A	802.11n (20MHz)		52 to 64	52, 60, 64	OFDM	BPSK	MCS0
A	802.11n (40MHz)		54 to 62	54, 62	OFDM	BPSK	MCS0
A	802.11ac (80MHz)		58	58	OFDM	BPSK	V0
A	802.11a	5500-5700	100 to 140	100, 116, 140	OFDM	BPSK	6.0
A	802.11n (20MHz)		100 to 140	100, 116, 140	OFDM	BPSK	MCS0
A	802.11n (40MHz)		102 to 134	102, 110, 134	OFDM	BPSK	MCS0
A	802.11ac (80MHz)		106	106	OFDM	BPSK	V0
A	802.11a	5725-5825	149 to 165	149, 157, 165	OFDM	BPSK	6.0
A	802.11n (20MHz)		149 to 165	149, 157, 165	OFDM	BPSK	MCS0
A	802.11n (40MHz)		151 to 159	151, 159	OFDM	BPSK	MCS0
A	802.11ac (80MHz)		155	155	OFDM	BPSK	V0



RADIATED EMISSION TEST (BELOW 1GHz):

- Pre-Scan has been conducted to determine the worst-case mode from all possible combinations between available modulations, data rates and antenna ports (if EUT with antenna diversity architecture).
- Following channel(s) was (were) selected for the final test as listed below.

EUT CONFIGURE MODE	MODE	FREQ. BAND (MHz)	AVAILABLE CHANNEL	TESTED CHANNEL	MODULATION TECHNOLOGY	MODULATION TYPE	DATA RATE (Mbps)
A	802.11a	5500-5700	100 to 140	36	OFDM	BPSK	6.0

POWER LINE CONDUCTED EMISSION TEST:

- Pre-Scan has been conducted to determine the worst-case mode from all possible combinations between available modulations, data rates and antenna ports (if EUT with antenna diversity architecture).
- Following channel(s) was (were) selected for the final test as listed below.

EUT CONFIGURE MODE	MODE	FREQ. BAND (MHz)	AVAILABLE CHANNEL	TESTED CHANNEL	MODULATION TECHNOLOGY	MODULATION TYPE	DATA RATE (Mbps)
A	802.11a	5500-5700	100 to 140	36	OFDM	BPSK	6.0

BANDEDGE MEASUREMENT:

- Pre-Scan has been conducted to determine the worst-case mode from all possible combinations between available modulations, data rates and antenna ports (if EUT with antenna diversity architecture).
- Following channel(s) was (were) selected for the final test as listed below.

EUT CONFIGURE MODE	MODE	FREQ. BAND (MHz)	AVAILABLE CHANNEL	TESTED CHANNEL	MODULATION TECHNOLOGY	MODULATION TYPE	DATA RATE (Mbps)
A	802.11a	5180-5240	36 to 48	36, 40, 48	OFDM	BPSK	6.0
A	802.11n (20MHz)		36 to 48	36, 40, 48	OFDM	BPSK	MCS0
A	802.11n (40MHz)		38 to 46	38, 46	OFDM	BPSK	MCS0
A	802.11ac (80MHz)		42	42	OFDM	BPSK	V0
A	802.11a	5260-5320	52 to 64	52, 60, 64	OFDM	BPSK	6.0
A	802.11n (20MHz)		52 to 64	52, 60, 64	OFDM	BPSK	MCS0
A	802.11n (40MHz)		54 to 62	54, 62	OFDM	BPSK	MCS0
A	802.11ac (80MHz)		58	58	OFDM	BPSK	V0
A	802.11a	5500-5700	100 to 140	100, 116, 140	OFDM	BPSK	6.0
A	802.11n (20MHz)		100 to 140	100, 116, 140	OFDM	BPSK	MCS0
A	802.11n (40MHz)		102 to 134	102, 110, 134	OFDM	BPSK	MCS0
A	802.11ac (80MHz)		106	106	OFDM	BPSK	V0
A	802.11a	5725-5825	149 to 165	149, 157, 165	OFDM	BPSK	6.0
A	802.11n (20MHz)		149 to 165	149, 157, 165	OFDM	BPSK	MCS0
A	802.11n (40MHz)		151 to 159	151, 159	OFDM	BPSK	MCS0
A	802.11ac (80MHz)		155	155	OFDM	BPSK	V0

**ANTENNA PORT CONDUCTED MEASUREMENT:**

- This item includes all test value of each mode, but only includes spectrum plot of worst value of each mode.
- Pre-Scan has been conducted to determine the worst-case mode from all possible combinations between available modulations, data rates and antenna ports (if EUT with antenna diversity architecture).
- Following channel(s) was (were) selected for the final test as listed below.

EUT CONFIGURE MODE	MODE	FREQ. BAND (MHz)	AVAILABLE CHANNEL	TESTED CHANNEL	MODULATION TECHNOLOGY	MODULATION TYPE	DATA RATE (Mbps)
A	802.11a	5180-5240	36 to 48	36, 40, 48	OFDM	BPSK	6.0
A	802.11n (20MHz)		36 to 48	36, 40, 48	OFDM	BPSK	MCS0
A	802.11n (40MHz)		38 to 46	38, 46	OFDM	BPSK	MCS0
A	802.11ac (80MHz)		42	42	OFDM	BPSK	V0
A	802.11a	5260-5320	52 to 64	52, 60, 64	OFDM	BPSK	6.0
A	802.11n (20MHz)		52 to 64	52, 60, 64	OFDM	BPSK	MCS0
A	802.11n (40MHz)		54 to 62	54, 62	OFDM	BPSK	MCS0
A	802.11ac (80MHz)		58	58	OFDM	BPSK	V0
A	802.11a	5500-5700	100 to 140	100, 116, 140	OFDM	BPSK	6.0
A	802.11n (20MHz)		100 to 140	100, 116, 140	OFDM	BPSK	MCS0
A	802.11n (40MHz)		102 to 134	102, 110, 134	OFDM	BPSK	MCS0
A	802.11ac (80MHz)		106	106	OFDM	BPSK	V0
A	802.11a	5725-5825	149 to 165	149, 157, 165	OFDM	BPSK	6.0
A	802.11n (20MHz)		149 to 165	149, 157, 165	OFDM	BPSK	MCS0
A	802.11n (40MHz)		151 to 159	151, 159	OFDM	BPSK	MCS0
A	802.11ac (80MHz)		155	155	OFDM	BPSK	V0

TEST CONDITION:

APPLICABLE TO	ENVIRONMENTAL CONDITIONS	INPUT POWER	TESTED BY
RE<1G	23deg. C, 62%RH	DC 24V By Adapter	Star Le
RE≥1G	23deg. C, 62%RH	DC 24V By Adapter	Star Le
PLC	24deg. C, 61%RH	DC 24V By Adapter	John Wen
APCM	23.5deg. C, 60%RH	DC 3.63V By battery	Rain Wang



2.3 DUTY CYCLE OF TEST SIGNAL

Duty cycle of test signal is < 98%, duty factor shall be considered.

802.11a: Duty cycle = 0.175/0.233=0.751, Duty factor = 10 * log(1/0.751) = 1.24

802.11n (20MHz): Duty cycle = 0.161/0.210 = 0.767, Duty factor = 10 * log(1/0.767) = 1.15

802.11n (40MHz): Duty cycle = 0.096/0.148 = 0.649, Duty factor = 10 * log(1/0.649) = 1.89

802.11ac (80MHz): Duty cycle = 0.064/0.105 = 0.610, Duty factor = 10 * log(1/0.610) = 2.15

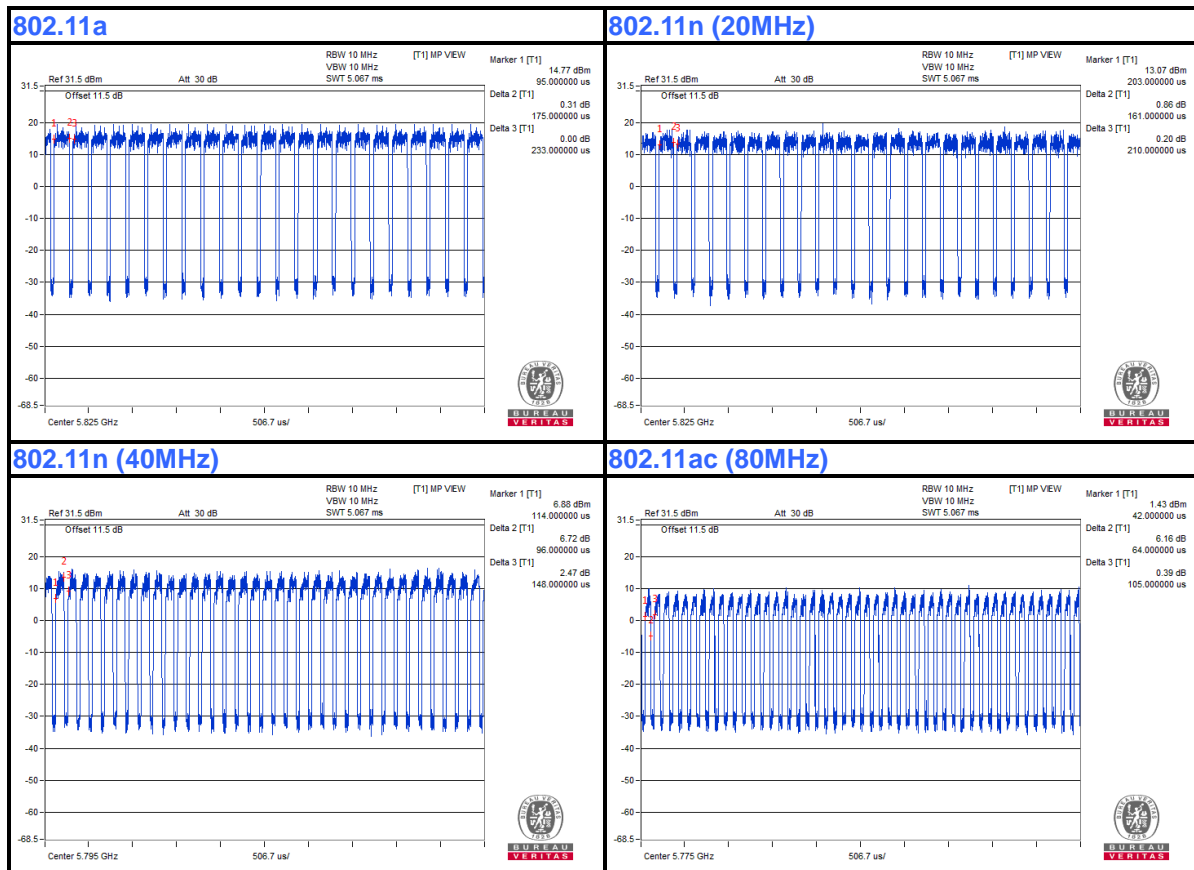



2.4 DESCRIPTION OF SUPPORT UNITS

The EUT has been tested as an independent unit together with other necessary accessories or support units. The following support units or accessories were used to form a representative test configuration during the tests.

NO.	PRODUCT	BRAND	MODEL NO.	SERIAL NO.	FCC ID
1	DC source	LONG WEI	PS-6403D	010934269	N/A
2	PC	HP	A6608CN	3CR83825X3	N/A

NO.	SIGNAL CABLE DESCRIPTION OF THE ABOVE SUPPORT UNITS
1	DC Line: Unshielded, Detachable 1.0m
2	AC Line: Unshielded, Detachable 1.5m

NOTE:

1. All power cords of the above support units are non shielded (1.8m).

2.4.1 CONFIGURATION OF SYSTEM UNDER TEST

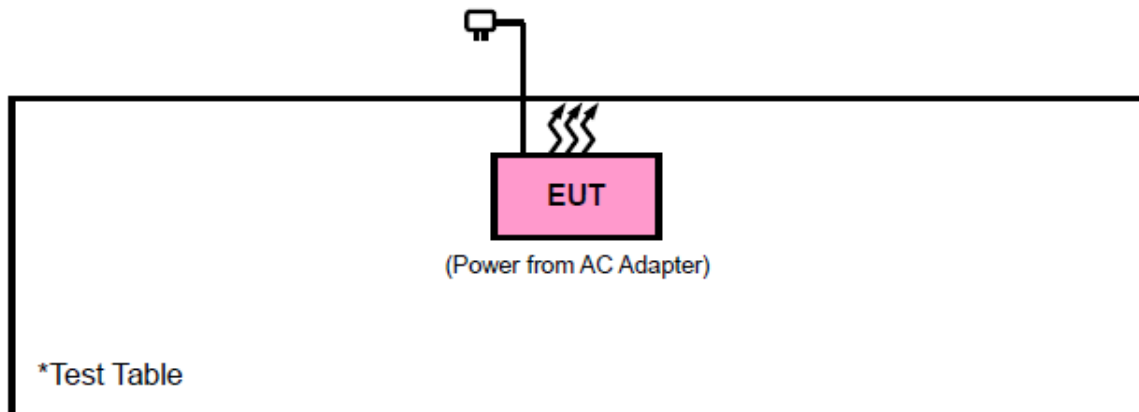



2.5 GENERAL DESCRIPTION OF APPLIED STANDARDS

The EUT is a RF Product. According to the specifications of the manufacturer, it must comply with the requirements of the following standards:

FCC Part 15, Subpart E (15.407)

KDB 789033 D02 General U-NII Test Procedures New Rules v02r01

ANSI C63.10-2013

All test items have been performed and recorded as per the above standards.

NOTE: The EUT is also considered as a kind of computer peripheral, because the connection to computer is necessary for typical use. It has been verified to comply with the requirements of FCC Part 15, Subpart B, Class B (sDOC). The test report has been issued separately.



3 TEST TYPES AND RESULTS

3.1 RADIATED EMISSION AND BANDEDGE MEASUREMENT

3.1.1 LIMITS OF RADIATED EMISSION AND BANDEDGE MEASUREMENT

Radiated emissions which fall in the restricted bands must comply with the radiated emission limits specified as below table:

FREQUENCIES (MHz)	FIELD STRENGTH (microvolts/meter)	MEASUREMENT DISTANCE (meters)
0.009 ~ 0.490	2400/F(kHz)	300
0.490 ~ 1.705	24000/F(kHz)	30
1.705 ~ 30.0	30	30
30 ~ 88	100	3
88 ~ 216	150	3
216 ~ 960	200	3
Above 960	500	3

NOTE:

1. The lower limit shall apply at the transition frequencies.
2. Emission level (dBuV/m) = 20 log Emission level (uV/m).
3. For frequencies above 1000MHz, the field strength limits are based on average detector, however, the peak field strength of any emission shall not exceed the maximum permitted average limits, specified above by more than 20dB under any condition of modulation.

3.1.2 LIMITS OF UNWANTED EMISSION

RESTRICTED BANDS	APPLICABLE TO	LIMIT	
	789033 D02 General UNII Test Procedures New Rules v01r02	FIELD STRENGTH AT 3m (dBµV/m)	
	PK : 74	AV : 54	
OUT OF THE RESTRICTED BANDS	APPLICABLE TO	EIRP LIMIT (dBm/MHz)	EQUIVALENT FIELD STRENGTH AT 3m (dBµV/m)
	15.407(b)(1)	PK : -27	PK : 68.3
	15.407(b)(2)		
	15.407(b)(3)		
	15.407(b)(4)	See note 2 (FCC 16-24)	



NOTE: The following formula is used to convert the equipment isotropic radiated power (eirp) to field strength:

$$E = \frac{1000000}{3} \sqrt{30 P} \text{ } \mu\text{V/m, where P is the eirp (Watts).}$$

2. All emissions shall be limited to a level of -27 dBm/MHz at 75 MHz or more above or below the band edge increasing linearly to 10 dBm/MHz at 25 MHz above or below the band edge, and from 25 MHz above or below the band edge increasing linearly to a level of 15.6 dBm/MHz at 5 MHz above or below the band edge, and from 5 MHz above or below the band edge increasing linearly to a level of 27 dBm/MHz at the band edge.

3.1.3 TEST INSTRUMENTS

Equipment	Manufacturer	Model No.	Serial No.	Last Cal.	Next Cal.
3m Semi-anechoic Chamber	ETS-LINDGREN	9m*6m*6m	Euroshieldpn-CT0001143-1216	Feb. 26,19	Feb. 25,20
Bilog Antenna	ETS-LINDGREN	3143B	00161965	Feb. 26,19	Feb. 25,20
Horn Antenna	ETS-LINDGREN	3117	00168728	Feb. 26,19	Feb. 25,20
Horn Antenna (18GHz-40GHz)	N/A	QWH-SL-18-40-K-SG/QMS-00361	15433	Nov. 21, 18	Nov. 20, 19
Test Software	E3	V 9.160323	N/A	N/A	N/A
Test Software	ADT	ADT_Radiated_V7.6.15.9.2	N/A	N/A	N/A
10dB Attenuator	JFW/USA	50HF-010-SMA	1505	Jun. 24,19	Jun. 23,20
MXE EMI Receiver	KEYSIGHT	N9038A-544	MY54450026	Feb. 26,19	Feb. 25,20
Signal Pre-Amplifier	EMSI	EMC 9135	980249	Jun. 24,19	Jun. 23,20
Signal Pre-Amplifier	EMSI	EMC 012645B	980257	Jun. 24,19	Jun. 23,20
Signal Pre-Amplifier	EMSI	EMC 184045B	980259	Jun. 24,19	Jun. 23,20

NOTE:

1. The calibration interval of the above test instruments is 12 months and the calibrations are traceable to CEPREI/CHINA, GRGT/CHINA and NIM/CHINA.
2. The test was performed in 3m Chamber.
3. The FCC Site Registration No. is 525120; The Designation No. is CN1171.



3.1.4 TEST PROCEDURES

- a. The EUT was placed on the top of a rotating table 0.8 meters (for below 1GHz) / 1.5 meters (for above 1GHz) above the ground at 3 meter chamber room for test. The table was rotated 360 degrees to determine the position of the highest radiation.
- b. The EUT was set 3 meters away from the interference-receiving antenna, which was mounted on the top of a variable-height antenna tower.
- c. The antenna is a broadband antenna, and its height is varied from one meter to four meters above the ground to determine the maximum value of the field strength. Both horizontal and vertical polarizations of the antenna are set to make the measurement.
- d. For each suspected emission, the EUT was arranged to its worst case and then the antenna was tuned to heights from 1 meter to 4 meters and the rotatable table was turned from 0 degrees to 360 degrees to find the maximum reading.
- e. The test-receiver system was set to Peak Detect Function and Specified Bandwidth with Maximum Hold Mode.
- f. If the emission level of the EUT in peak mode was 10dB lower than the limit specified, then testing could be stopped and the peak values of the EUT would be reported. Otherwise the emissions that did not have 10dB margin would be re-tested one by one using peak, quasi-peak or average method as specified and then reported in a data sheet.

NOTE:

1. The resolution bandwidth and video bandwidth of test receiver/spectrum analyzer is 120kHz for Peak detection (PK) and Quasi-peak detection (QP) at frequency below 1GHz.
2. The resolution bandwidth of test receiver/spectrum analyzer is 1MHz and video bandwidth is 3MHz for Peak detection at frequency above 1GHz.
3. The resolution bandwidth of test receiver/spectrum analyzer is 1MHz and the video bandwidth is 10Hz for Average detection (AV) at frequency above 1GHz.
4. All modes of operation were investigated and the worst-case emissions are reported.

3.1.5 DEVIATION FROM TEST STANDARD

No deviation.



3.1.6 TEST SETUP

< Frequency Range 30MHz~1GHz >

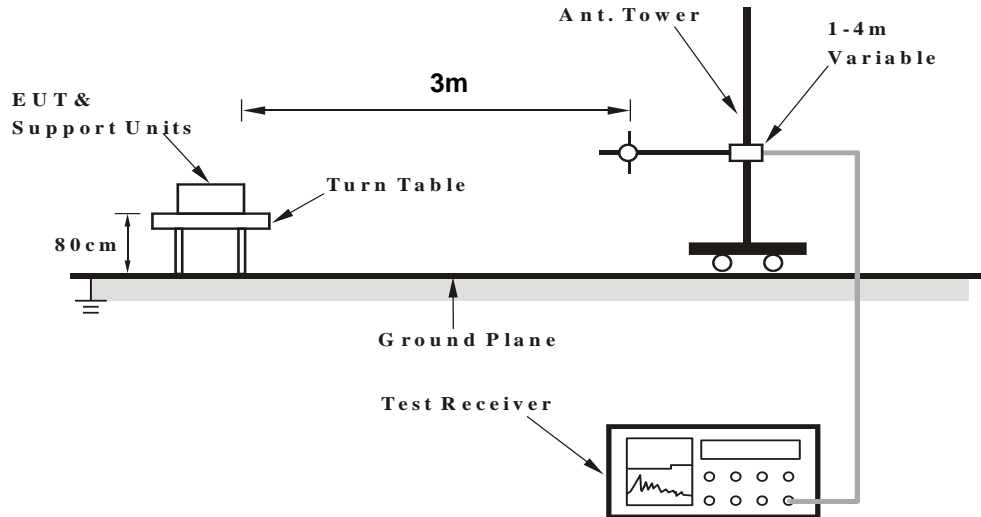

<Frequency Range above 1GHz>

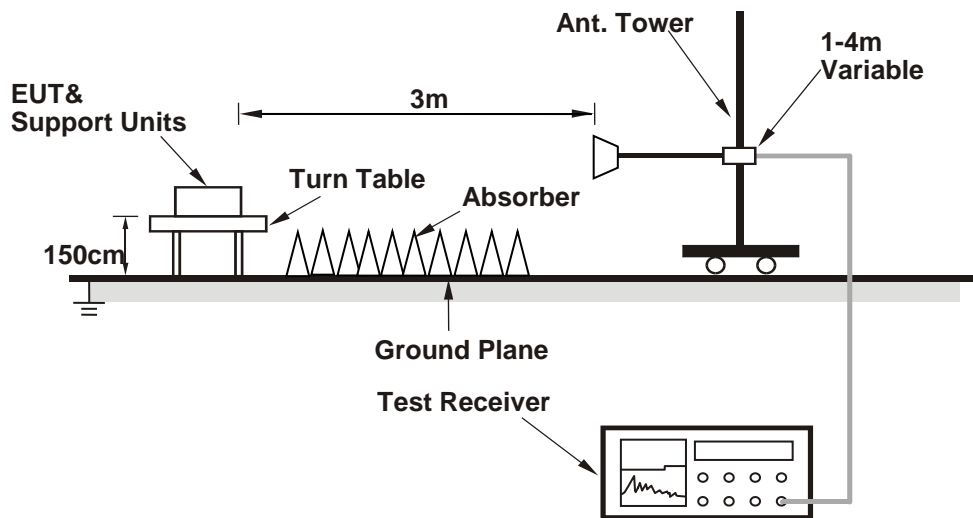

For the actual test configuration, please refer to the attached file (Test Setup Photo).



3.1.7 EUT OPERATING CONDITION

- a. Set the EUT under full load condition and placed them on a testing table.
- b. Set the transmitter part of EUT under transmission condition continuously at specific channel frequency.
- c. The necessary accessories enable the EUT in full functions.



3.1.8 TEST RESULTS

BELOW 1GHz WORST-CASE DATA:

30 MHz – 1GHz data:

802.11a

CHANNEL	TX Channel 36	DETECTOR FUNCTION	Quasi-Peak (QP)
FREQUENCY RANGE	30MHz ~ 1GHz		

ANTENNA POLARITY & TEST DISTANCE: HORIZONTAL AT 3 M										
FREQ. (MHz)	EMISSION LEVEL (dBuV/m)	READ LEVEL (dBuV)	LIMIT (dBuV/m)	MARGIN (dB)	ANTENNA FACTOR (dB /m)	CABLE LOSS (dB)	PREAMP FACTOR (dB)	ANTENNA HEIGHT (cm)	TABLE ANGLE (Degree)	REMARK
56.32	27.26	57.12	40	-12.74	6.44	1.04	37.34	116	230	QP
102.36	30.5	58.23	43.5	-13	7.92	1.33	36.98	108	69	QP
175.42	23.48	48.52	43.5	-20.02	9.97	1.69	36.7	100	287	QP
225.31	28.79	52.14	46	-17.21	11.26	1.92	36.53	145	120	QP
285.64	32.1	53.62	46	-13.9	12.83	2.16	36.51	170	189	QP
455.32	25.99	42.16	46	-20.01	17.86	2.82	36.85	100	167	QP

REMARKS:

1. Emission level (dBuV/m) = Raw Value (dBuV) + Correction Factor (dB/m).
2. Correction Factor (dB/m) = Antenna Factor (dB/m) + Cable Factor (dB).
3. The other emission levels were very low against the limit.
4. Margin value = Emission level – Limit value.

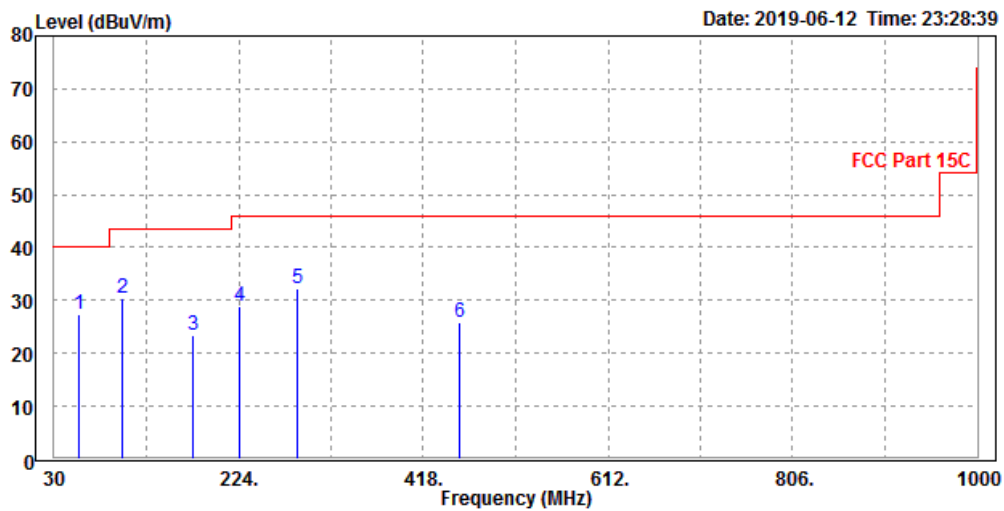



CHANNEL	Channel 36	DETECTOR FUNCTION	Quasi-Peak (QP)
FREQUENCY RANGE	30MHz ~ 1GHz		

ANTENNA POLARITY & TEST DISTANCE: VERTICAL AT 3 M										
FREQ. (MHz)	EMISSION LEVEL (dBuV/m)	READ LEVEL (dBuV)	LIMIT (dBuV/m)	MARGIN (dB)	ANTENNA FACTOR (dB /m)	CABLE LOSS (dB)	PREAMP FACTOR (dB)	ANTENNA HEIGHT (cm)	TABLE ANGLE (Degree)	REMARK
59.36	20.43	50.27	40	-19.57	6.41	1.07	37.32	160	230	QP
158.64	27.3	52.34	43.5	-16.2	10.06	1.65	36.75	103	243	QP
185.62	31.38	56.34	43.5	-12.12	9.96	1.73	36.65	100	188	QP
225.63	23.35	46.68	46	-22.65	11.28	1.92	36.53	200	0	QP
325.12	25.5	45.69	46	-20.5	14.06	2.31	36.56	104	217	QP
452.31	35.03	51.24	46	-10.97	17.83	2.81	36.85	120	142	QP

REMARKS:

1. Emission level (dBuV/m) = Raw Value (dBuV) + Correction Factor (dB/m).
2. Correction Factor (dB/m) = Antenna Factor (dB/m) + Cable Factor (dB).
3. The other emission levels were very low against the limit.
4. Margin value = Emission level – Limit value.

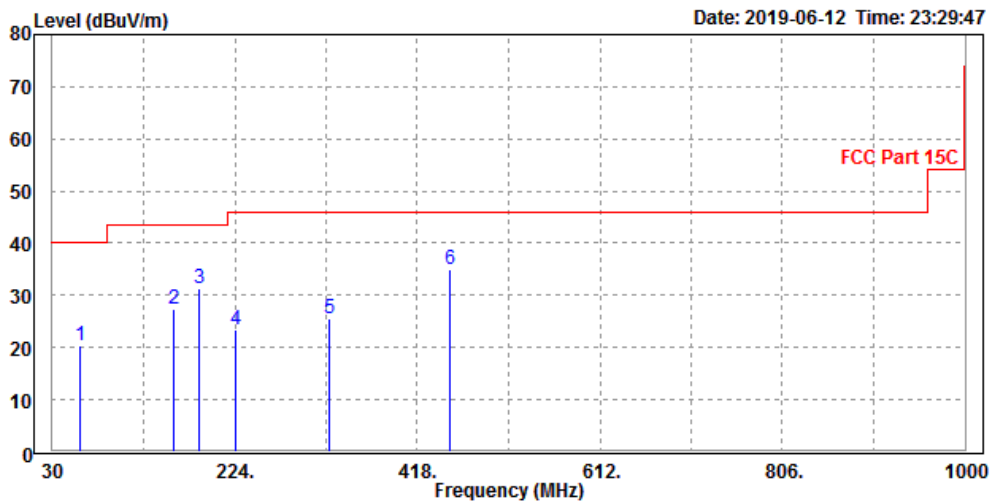



ABOVE 1GHz WORST-CASE DATA:

Note: For higher frequency, the emission is too low to be detected.

Band 1

802.11a

CHANNEL	TX Channel 36	DETECTOR FUNCTION	Peak (PK)
FREQUENCY RANGE	1GHz ~ 40GHz		Average (AV)

ANTENNA POLARITY & TEST DISTANCE: HORIZONTAL AT 3 M										
FREQ. (MHz)	EMISSION LEVEL (dBuV/m)	READ LEVEL (dBuV)	LIMIT (dBuV/m)	MARGIN (dB)	ANTENNA FACTOR (dB /m)	CABLE LOSS (dB)	PREAMP FACTOR (dB)	ANTENNA HEIGHT (cm)	TABLE ANGLE (Degree)	REMARK
5150	66.18	67.85	74	-7.82	37.26	7.42	46.35	170	351	Peak
5150	50.95	52.62	54	-3.05	37.26	7.42	46.35	170	351	Average
5180	111.03	112.68			37.27	7.43	46.35	170	351	Peak
5180	101.51	103.16			37.27	7.43	46.35	170	351	Average
5350	59.15	60.64	74	-14.85	37.34	7.47	46.3	170	351	Peak
5350	48.99	50.48	54	-5.01	37.34	7.47	46.3	170	351	Average
ANTENNA POLARITY & TEST DISTANCE: VERTICAL AT 3 M										
FREQ. (MHz)	EMISSION LEVEL (dBuV/m)	READ LEVEL (dBuV)	LIMIT (dBuV/m)	MARGIN (dB)	ANTENNA FACTOR (dB /m)	CABLE LOSS (dB)	PREAMP FACTOR (dB)	ANTENNA HEIGHT (cm)	TABLE ANGLE (Degree)	REMARK
5150	64.22	65.89	74	-9.78	37.26	7.42	46.35	100	93	Peak
5150	50.25	51.92	54	-3.75	37.26	7.42	46.35	100	93	Average
5180	110.33	111.98			37.27	7.43	46.35	100	93	Peak
5180	100.73	102.38			37.27	7.43	46.35	100	93	Average
5350	58.86	60.35	74	-15.14	37.34	7.47	46.3	100	93	Peak
5350	48.72	50.21	54	-5.28	37.34	7.47	46.3	100	93	Average

REMARKS:

- Emission Level = Read Level+ Antenna Factor + Cable Loss- Preamp Factor
Margin value = Emission level – Limit value.
- 5180MHz: Fundamental frequency.



CHANNEL	TX Channel 40	DETECTOR FUNCTION	Peak (PK)
FREQUENCY RANGE	1GHz ~ 40GHz		Average (AV)

ANTENNA POLARITY & TEST DISTANCE: HORIZONTAL AT 3 M

FREQ. (MHz)	EMISSION LEVEL (dBuV/m)	READ LEVEL (dBuV)	LIMIT (dBuV/m)	MARGIN (dB)	ANTENNA FACTOR (dB /m)	CABLE LOSS (dB)	PREAMP FACTOR (dB)	ANTENNA HEIGHT (cm)	TABLE ANGLE (Degree)	REMARK
5150	59.56	61.23	74	-14.44	37.26	7.42	46.35	100	143	Peak
5150	49.75	51.42	54	-4.25	37.26	7.42	46.35	100	143	Average
5200	109.62	111.25			37.28	7.43	46.34	100	143	Peak
5200	100.91	102.54			37.28	7.43	46.34	100	143	Average
5350	58.37	59.86	74	-15.63	37.34	7.47	46.3	100	143	Peak
5350	48.08	49.57	54	-5.92	37.34	7.47	46.3	100	143	Average

ANTENNA POLARITY & TEST DISTANCE: VERTICAL AT 3 M

FREQ. (MHz)	EMISSION LEVEL (dBuV/m)	READ LEVEL (dBuV)	LIMIT (dBuV/m)	MARGIN (dB)	ANTENNA FACTOR (dB /m)	CABLE LOSS (dB)	PREAMP FACTOR (dB)	ANTENNA HEIGHT (cm)	TABLE ANGLE (Degree)	REMARK
5150	59.89	61.56	74	-14.11	37.26	7.42	46.35	100	94	Peak
5150	49.46	51.13	54	-4.54	37.26	7.42	46.35	100	94	Average
5200	109.99	111.62			37.28	7.43	46.34	100	94	Peak
5200	99.91	101.54			37.28	7.43	46.34	100	94	Average
5350	58.68	60.17	74	-15.32	37.34	7.47	46.3	100	94	Peak
5350	48.59	50.08	54	-5.41	37.34	7.47	46.3	100	94	Average

REMARKS:

- Emission Level = Read Level+ Antenna Factor + Cable Loss- Preamp Factor
Margin value = Emission level – Limit value.
- 5200MHz: Fundamental frequency.



CHANNEL	TX Channel 48	DETECTOR FUNCTION	Peak (PK)
FREQUENCY RANGE	1GHz ~ 40GHz		Average (AV)

ANTENNA POLARITY & TEST DISTANCE: HORIZONTAL AT 3 M

FREQ. (MHz)	EMISSION LEVEL (dBuV/m)	READ LEVEL (dBuV)	LIMIT (dBuV/m)	MARGIN (dB)	ANTENNA FACTOR (dB /m)	CABLE LOSS (dB)	PREAMP FACTOR (dB)	ANTENNA HEIGHT (cm)	TABLE ANGLE (Degree)	REMARK
5150	58.89	60.56	74	-15.11	37.26	7.42	46.35	100	138	Peak
5150	48.74	50.41	54	-5.26	37.26	7.42	46.35	100	138	Average
5240	111	112.59			37.3	7.44	46.33	100	138	Peak
5240	101.69	103.28			37.3	7.44	46.33	100	138	Average
5350	58.4	59.89	74	-15.6	37.34	7.47	46.3	100	138	Peak
5350	48.63	50.12	54	-5.37	37.34	7.47	46.3	100	138	Average

ANTENNA POLARITY & TEST DISTANCE: VERTICAL AT 3 M

FREQ. (MHz)	EMISSION LEVEL (dBuV/m)	READ LEVEL (dBuV)	LIMIT (dBuV/m)	MARGIN (dB)	ANTENNA FACTOR (dB /m)	CABLE LOSS (dB)	PREAMP FACTOR (dB)	ANTENNA HEIGHT (cm)	TABLE ANGLE (Degree)	REMARK
5150	58.95	60.62	74	-15.05	37.26	7.42	46.35	100	0	Peak
5150	48.72	50.39	54	-5.28	37.26	7.42	46.35	100	0	Average
5240	109.69	111.28			37.3	7.44	46.33	100	0	Peak
5240	100.86	102.45			37.3	7.44	46.33	100	0	Average
5350	58.18	59.67	74	-15.82	37.34	7.47	46.3	100	0	Peak
5350	48.26	49.75	54	-5.74	37.34	7.47	46.3	100	0	Average

REMARKS:

- Emission Level = Read Level+ Antenna Factor + Cable Loss- Preamp Factor
Margin value = Emission level – Limit value.
- 5240MHz: Fundamental frequency.



802.11n (20MHz)

CHANNEL	TX Channel 36	DETECTOR FUNCTION	Peak (PK)
FREQUENCY RANGE	1GHz ~ 40GHz		Average (AV)

ANTENNA POLARITY & TEST DISTANCE: HORIZONTAL AT 3 M

FREQ. (MHz)	EMISSION LEVEL (dBuV/m)	READ LEVEL (dBuV)	LIMIT (dBuV/m)	MARGIN (dB)	ANTENNA FACTOR (dB /m)	CABLE LOSS (dB)	PREAMP FACTOR (dB)	ANTENNA HEIGHT (cm)	TABLE ANGLE (Degree)	REMARK
5150	63	64.67	74	-11	37.26	7.42	46.35	100	150	Peak
5150	50.38	52.05	54	-3.62	37.26	7.42	46.35	100	150	Average
5180	109.01	110.66			37.27	7.43	46.35	100	150	Peak
5180	98.58	100.23			37.27	7.43	46.35	100	150	Average
5350	58.82	60.31	74	-15.18	37.34	7.47	46.3	100	150	Peak
5350	48.93	50.42	54	-5.07	37.34	7.47	46.3	100	150	Average

ANTENNA POLARITY & TEST DISTANCE: VERTICAL AT 3 M

FREQ. (MHz)	EMISSION LEVEL (dBuV/m)	READ LEVEL (dBuV)	LIMIT (dBuV/m)	MARGIN (dB)	ANTENNA FACTOR (dB /m)	CABLE LOSS (dB)	PREAMP FACTOR (dB)	ANTENNA HEIGHT (cm)	TABLE ANGLE (Degree)	REMARK
5150	62.91	64.58	74	-11.09	37.26	7.42	46.35	100	96	Peak
5150	50.02	51.69	54	-3.98	37.26	7.42	46.35	100	96	Average
5180	108.92	110.57			37.27	7.43	46.35	100	96	Peak
5180	98.14	99.79			37.27	7.43	46.35	100	96	Average
5350	57.78	59.27	74	-16.22	37.34	7.47	46.3	100	96	Peak
5350	47.47	48.96	54	-6.53	37.34	7.47	46.3	100	96	Average

REMARKS:

- Emission Level = Read Level+ Antenna Factor + Cable Loss- Preamp Factor
Margin value = Emission level – Limit value.
- 5180MHz: Fundamental frequency.



CHANNEL	TX Channel 40	DETECTOR FUNCTION	Peak (PK)
FREQUENCY RANGE	1GHz ~ 40GHz		Average (AV)

ANTENNA POLARITY & TEST DISTANCE: HORIZONTAL AT 3 M										
FREQ. (MHz)	EMISSION LEVEL (dBuV/m)	READ LEVEL (dBuV)	LIMIT (dBuV/m)	MARGIN (dB)	ANTENNA FACTOR (dB /m)	CABLE LOSS (dB)	PREAMP FACTOR (dB)	ANTENNA HEIGHT (cm)	TABLE ANGLE (Degree)	REMARK
5150	59.75	61.42	74	-14.25	37.26	7.42	46.35	100	96	Peak
5150	49.69	51.36	54	-4.31	37.26	7.42	46.35	100	96	Average
5200	109.39	111.02			37.28	7.43	46.34	100	96	Peak
5200	99.72	101.35			37.28	7.43	46.34	100	96	Average
5350	59.08	60.57	74	-14.92	37.34	7.47	46.3	100	96	Peak
5350	48.17	49.66	54	-5.83	37.34	7.47	46.3	100	96	Average
ANTENNA POLARITY & TEST DISTANCE: VERTICAL AT 3 M										
FREQ. (MHz)	EMISSION LEVEL (dBuV/m)	READ LEVEL (dBuV)	LIMIT (dBuV/m)	MARGIN (dB)	ANTENNA FACTOR (dB /m)	CABLE LOSS (dB)	PREAMP FACTOR (dB)	ANTENNA HEIGHT (cm)	TABLE ANGLE (Degree)	REMARK
5150	58.78	60.45	74	-15.22	37.26	7.42	46.35	100	136	Peak
5150	49.59	51.26	54	-4.41	37.26	7.42	46.35	100	136	Average
5200	108.71	110.34			37.28	7.43	46.34	100	136	Peak
5200	98.28	99.91			37.28	7.43	46.34	100	136	Average
5350	58.38	59.87	74	-15.62	37.34	7.47	46.3	100	136	Peak
5350	48.67	50.16	54	-5.33	37.34	7.47	46.3	100	136	Average

REMARKS:

- Emission Level = Read Level+ Antenna Factor + Cable Loss- Preamp Factor
Margin value = Emission level – Limit value.
- 5200MHz: Fundamental frequency.



CHANNEL	TX Channel 48	DETECTOR FUNCTION	Peak (PK)
FREQUENCY RANGE	1GHz ~ 40GHz		Average (AV)

ANTENNA POLARITY & TEST DISTANCE: HORIZONTAL AT 3 M

FREQ. (MHz)	EMISSION LEVEL (dBuV/m)	READ LEVEL (dBuV)	LIMIT (dBuV/m)	MARGIN (dB)	ANTENNA FACTOR (dB /m)	CABLE LOSS (dB)	PREAMP FACTOR (dB)	ANTENNA HEIGHT (cm)	TABLE ANGLE (Degree)	REMARK
5150	58.11	59.78	74	-15.89	37.26	7.42	46.35	100	155	Peak
5150	47.89	49.56	54	-6.11	37.26	7.42	46.35	100	155	Average
5240	108.26	109.85			37.3	7.44	46.33	100	155	Peak
5240	97.05	98.64			37.3	7.44	46.33	100	155	Average
5350	59.02	60.51	74	-14.98	37.34	7.47	46.3	100	155	Peak
5350	48.66	50.15	54	-5.34	37.34	7.47	46.3	100	155	Average

ANTENNA POLARITY & TEST DISTANCE: VERTICAL AT 3 M

FREQ. (MHz)	EMISSION LEVEL (dBuV/m)	READ LEVEL (dBuV)	LIMIT (dBuV/m)	MARGIN (dB)	ANTENNA FACTOR (dB /m)	CABLE LOSS (dB)	PREAMP FACTOR (dB)	ANTENNA HEIGHT (cm)	TABLE ANGLE (Degree)	REMARK
5150	58.14	59.81	74	-15.86	37.26	7.42	46.35	100	97	Peak
5150	48.19	49.86	54	-5.81	37.26	7.42	46.35	100	97	Average
5240	109.08	110.67			37.3	7.44	46.33	100	97	Peak
5240	98.7	100.29			37.3	7.44	46.33	100	97	Average
5350	58.76	60.25	74	-15.24	37.34	7.47	46.3	100	97	Peak
5350	48.99	50.48	54	-5.01	37.34	7.47	46.3	100	97	Average

REMARKS:

- Emission Level = Read Level+ Antenna Factor + Cable Loss- Preamp Factor
Margin value = Emission level – Limit value.
- 5240MHz: Fundamental frequency.



802.11n (40MHz)

CHANNEL	TX Channel 38	DETECTOR FUNCTION	Peak (PK)
FREQUENCY RANGE	1GHz ~ 40GHz		Average (AV)

ANTENNA POLARITY & TEST DISTANCE: HORIZONTAL AT 3 M										
FREQ. (MHz)	EMISSION LEVEL (dBuV/m)	READ LEVEL (dBuV)	LIMIT (dBuV/m)	MARGIN (dB)	ANTENNA FACTOR (dB /m)	CABLE LOSS (dB)	PREAMP FACTOR (dB)	ANTENNA HEIGHT (cm)	TABLE ANGLE (Degree)	REMARK
5150	64.19	65.86	74	-9.81	37.26	7.42	46.35	100	160	Peak
5150	50.89	52.56	54	-3.11	37.26	7.42	46.35	100	160	Average
5190	104.07	105.7			37.28	7.43	46.34	100	160	Peak
5190	94.72	96.35			37.28	7.43	46.34	100	160	Average
5350	58.63	60.12	74	-15.37	37.34	7.47	46.3	100	160	Peak
5350	47.77	49.26	54	-6.23	37.34	7.47	46.3	100	160	Average
ANTENNA POLARITY & TEST DISTANCE: VERTICAL AT 3 M										
FREQ. (MHz)	EMISSION LEVEL (dBuV/m)	READ LEVEL (dBuV)	LIMIT (dBuV/m)	MARGIN (dB)	ANTENNA FACTOR (dB /m)	CABLE LOSS (dB)	PREAMP FACTOR (dB)	ANTENNA HEIGHT (cm)	TABLE ANGLE (Degree)	REMARK
5150	63.8	65.47	74	-10.2	37.26	7.42	46.35	100	86	Peak
5150	50.09	51.76	54	-3.91	37.26	7.42	46.35	100	86	Average
5190	103.25	104.88			37.28	7.43	46.34	100	86	Peak
5190	92	93.63			37.28	7.43	46.34	100	86	Average
5350	58	59.49	74	-16	37.34	7.47	46.3	100	86	Peak
5350	48.86	50.35	54	-5.14	37.34	7.47	46.3	100	86	Average

REMARKS:

- Emission Level = Read Level+ Antenna Factor + Cable Loss- Preamp Factor
Margin value = Emission level – Limit value.
- 5190MHz: Fundamental frequency.



CHANNEL	TX Channel 46	DETECTOR FUNCTION	Peak (PK)
FREQUENCY RANGE	1GHz ~ 40GHz		Average (AV)

ANTENNA POLARITY & TEST DISTANCE: HORIZONTAL AT 3 M

FREQ. (MHz)	EMISSION LEVEL (dBuV/m)	READ LEVEL (dBuV)	LIMIT (dBuV/m)	MARGIN (dB)	ANTENNA FACTOR (dB /m)	CABLE LOSS (dB)	PREAMP FACTOR (dB)	ANTENNA HEIGHT (cm)	TABLE ANGLE (Degree)	REMARK
5150	57.96	59.63	74	-16.04	37.26	7.42	46.35	100	153	Peak
5150	49.22	50.89	54	-4.78	37.26	7.42	46.35	100	153	Average
5230	105.11	106.71			37.29	7.44	46.33	100	153	Peak
5230	94.08	95.68			37.29	7.44	46.33	100	153	Average
5350	58.2	59.69	74	-15.8	37.34	7.47	46.3	100	153	Peak
5350	48.09	49.58	54	-5.91	37.34	7.47	46.3	100	153	Average

ANTENNA POLARITY & TEST DISTANCE: VERTICAL AT 3 M

FREQ. (MHz)	EMISSION LEVEL (dBuV/m)	READ LEVEL (dBuV)	LIMIT (dBuV/m)	MARGIN (dB)	ANTENNA FACTOR (dB /m)	CABLE LOSS (dB)	PREAMP FACTOR (dB)	ANTENNA HEIGHT (cm)	TABLE ANGLE (Degree)	REMARK
5150	59.85	61.52	74	-14.15	37.26	7.42	46.35	100	87	Peak
5150	49.71	51.38	54	-4.29	37.26	7.42	46.35	100	87	Average
5230	105.63	107.23			37.29	7.44	46.33	100	87	Peak
5230	95.85	97.45			37.29	7.44	46.33	100	87	Average
5350	58.99	60.48	74	-15.01	37.34	7.47	46.3	100	87	Peak
5350	48.73	50.22	54	-5.27	37.34	7.47	46.3	100	87	Average

REMARKS:

- Emission Level = Read Level+ Antenna Factor + Cable Loss- Preamp Factor
Margin value = Emission level – Limit value.
- 5230MHz: Fundamental frequency.



802.11ac (80MHz)

CHANNEL	TX Channel 42	DETECTOR FUNCTION	Peak (PK)
FREQUENCY RANGE	1GHz ~ 40GHz		Average (AV)

ANTENNA POLARITY & TEST DISTANCE: HORIZONTAL AT 3 M

FREQ. (MHz)	EMISSION LEVEL (dBuV/m)	READ LEVEL (dBuV)	LIMIT (dBuV/m)	MARGIN (dB)	ANTENNA FACTOR (dB /m)	CABLE LOSS (dB)	PREAMP FACTOR (dB)	ANTENNA HEIGHT (cm)	TABLE ANGLE (Degree)	REMARK
5150	62.56	64.23	74	-11.44	37.26	7.42	46.35	100	158	Peak
5150	50.9	52.57	54	-3.1	37.26	7.42	46.35	100	158	Average
5210	102.79	104.41			37.28	7.44	46.34	100	158	Peak
5210	90.73	92.35			37.28	7.44	46.34	100	158	Average
5350	60.03	61.52	74	-13.97	37.34	7.47	46.3	100	158	Peak
5350	49.77	51.26	54	-4.23	37.34	7.47	46.3	100	158	Average

ANTENNA POLARITY & TEST DISTANCE: VERTICAL AT 3 M

FREQ. (MHz)	EMISSION LEVEL (dBuV/m)	READ LEVEL (dBuV)	LIMIT (dBuV/m)	MARGIN (dB)	ANTENNA FACTOR (dB /m)	CABLE LOSS (dB)	PREAMP FACTOR (dB)	ANTENNA HEIGHT (cm)	TABLE ANGLE (Degree)	REMARK
5150	62.92	64.59	74	-11.08	37.26	7.42	46.35	100	0	Peak
5150	50.79	52.46	54	-3.21	37.26	7.42	46.35	100	0	Average
5210	102.76	104.38			37.28	7.44	46.34	100	0	Peak
5210	91.67	93.29			37.28	7.44	46.34	100	0	Average
5350	59.05	60.54	74	-14.95	37.34	7.47	46.3	100	0	Peak
5350	48.69	50.18	54	-5.31	37.34	7.47	46.3	100	0	Average

REMARKS:

- Emission Level = Read Level+ Antenna Factor + Cable Loss- Preamp Factor
Margin value = Emission level – Limit value.
- 5210MHz: Fundamental frequency.



Band 2
802.11a

CHANNEL	TX Channel 52	DETECTOR FUNCTION	Peak (PK)
FREQUENCY RANGE	1GHz ~ 40GHz		Average (AV)

ANTENNA POLARITY & TEST DISTANCE: HORIZONTAL AT 3 M

FREQ. (MHz)	EMISSION LEVEL (dBuV/m)	READ LEVEL (dBuV)	LIMIT (dBuV/m)	MARGIN (dB)	ANTENNA FACTOR (dB /m)	CABLE LOSS (dB)	PREAMP FACTOR (dB)	ANTENNA HEIGHT (cm)	TABLE ANGLE (Degree)	REMARK
5150	59.09	60.76	74	-14.91	37.26	7.42	46.35	133	155	Peak
5150	48.74	50.41	54	-5.26	37.26	7.42	46.35	133	155	Average
5260	109.28	110.85			37.3	7.45	46.32	133	155	Peak
5260	99.09	100.66			37.3	7.45	46.32	133	155	Average
5350	59.26	60.75	74	-14.74	37.34	7.47	46.3	133	155	Peak
5350	48.77	50.26	54	-5.23	37.34	7.47	46.3	133	155	Average

ANTENNA POLARITY & TEST DISTANCE: VERTICAL AT 3 M

FREQ. (MHz)	EMISSION LEVEL (dBuV/m)	READ LEVEL (dBuV)	LIMIT (dBuV/m)	MARGIN (dB)	ANTENNA FACTOR (dB /m)	CABLE LOSS (dB)	PREAMP FACTOR (dB)	ANTENNA HEIGHT (cm)	TABLE ANGLE (Degree)	REMARK
5150	62.89	64.56	74	-11.11	37.26	7.42	46.35	131	113	Peak
5150	48.45	50.12	54	-5.55	37.26	7.42	46.35	131	113	Average
5260	107.95	109.52			37.3	7.45	46.32	131	113	Peak
5260	95.19	96.76			37.3	7.45	46.32	131	113	Average
5350	58.85	60.34	74	-15.15	37.34	7.47	46.3	131	113	Peak
5350	48.67	50.16	54	-5.33	37.34	7.47	46.3	131	113	Average

REMARKS:

- Emission Level = Read Level+ Antenna Factor + Cable Loss- Preamp Factor
Margin value = Emission level – Limit value.
- 5260MHz: Fundamental frequency.



CHANNEL	TX Channel 60	DETECTOR FUNCTION	Peak (PK)
FREQUENCY RANGE	1GHz ~ 40GHz		Average (AV)

ANTENNA POLARITY & TEST DISTANCE: HORIZONTAL AT 3 M

FREQ. (MHz)	EMISSION LEVEL (dBuV/m)	READ LEVEL (dBuV)	LIMIT (dBuV/m)	MARGIN (dB)	ANTENNA FACTOR (dB /m)	CABLE LOSS (dB)	PREAMP FACTOR (dB)	ANTENNA HEIGHT (cm)	TABLE ANGLE (Degree)	REMARK
5150	58.81	60.48	74	-15.19	37.26	7.42	46.35	100	135	Peak
5150	48.42	50.09	54	-5.58	37.26	7.42	46.35	100	135	Average
5300	108.99	110.52			37.32	7.46	46.31	100	135	Peak
5300	98.33	99.86			37.32	7.46	46.31	100	135	Average
5350	59.75	61.24	74	-14.25	37.34	7.47	46.3	100	135	Peak
5350	48.86	50.35	54	-5.14	37.34	7.47	46.3	100	135	Average

ANTENNA POLARITY & TEST DISTANCE: VERTICAL AT 3 M

FREQ. (MHz)	EMISSION LEVEL (dBuV/m)	READ LEVEL (dBuV)	LIMIT (dBuV/m)	MARGIN (dB)	ANTENNA FACTOR (dB /m)	CABLE LOSS (dB)	PREAMP FACTOR (dB)	ANTENNA HEIGHT (cm)	TABLE ANGLE (Degree)	REMARK
5150	58.19	59.86	74	-15.81	37.26	7.42	46.35	100	98	Peak
5150	48.09	49.76	54	-5.91	37.26	7.42	46.35	100	98	Average
5300	109.11	110.64			37.32	7.46	46.31	100	98	Peak
5300	99.05	100.58			37.32	7.46	46.31	100	98	Average
5350	59.02	60.51	74	-14.98	37.34	7.47	46.3	100	98	Peak
5350	48.38	49.87	54	-5.62	37.34	7.47	46.3	100	98	Average

REMARKS:

- Emission Level = Read Level+ Antenna Factor + Cable Loss- Preamp Factor
Margin value = Emission level – Limit value.
- 5300MHz: Fundamental frequency.



CHANNEL	TX Channel 64	DETECTOR FUNCTION	Peak (PK)
FREQUENCY RANGE	1GHz ~ 40GHz		Average (AV)

ANTENNA POLARITY & TEST DISTANCE: HORIZONTAL AT 3 M

FREQ. (MHz)	EMISSION LEVEL (dBuV/m)	READ LEVEL (dBuV)	LIMIT (dBuV/m)	MARGIN (dB)	ANTENNA FACTOR (dB /m)	CABLE LOSS (dB)	PREAMP FACTOR (dB)	ANTENNA HEIGHT (cm)	TABLE ANGLE (Degree)	REMARK
5150	58.58	60.25	74	-15.42	37.26	7.42	46.35	100	195	Peak
5150	48.69	50.36	54	-5.31	37.26	7.42	46.35	100	195	Average
5320	108.69	110.2			37.33	7.46	46.3	100	195	Peak
5320	98.6	100.11			37.33	7.46	46.3	100	195	Average
5350	62.08	63.57	74	-11.92	37.34	7.47	46.3	100	195	Peak
5350	50.85	52.34	54	-3.15	37.34	7.47	46.3	100	195	Average

ANTENNA POLARITY & TEST DISTANCE: VERTICAL AT 3 M

FREQ. (MHz)	EMISSION LEVEL (dBuV/m)	READ LEVEL (dBuV)	LIMIT (dBuV/m)	MARGIN (dB)	ANTENNA FACTOR (dB /m)	CABLE LOSS (dB)	PREAMP FACTOR (dB)	ANTENNA HEIGHT (cm)	TABLE ANGLE (Degree)	REMARK
5150	58.78	60.45	74	-15.22	37.26	7.42	46.35	100	0	Peak
5150	48.65	50.32	54	-5.35	37.26	7.42	46.35	100	0	Average
5320	109.69	111.2			37.33	7.46	46.3	100	0	Peak
5320	99.64	101.15			37.33	7.46	46.3	100	0	Average
5350	62.76	64.25	74	-11.24	37.34	7.47	46.3	100	0	Peak
5350	50.49	51.98	54	-3.51	37.34	7.47	46.3	100	0	Average

REMARKS:

- Emission Level = Read Level+ Antenna Factor + Cable Loss- Preamp Factor
Margin value = Emission level – Limit value.
- 5320MHz: Fundamental frequency.



802.11n (20MHz)

CHANNEL	TX Channel 52	DETECTOR FUNCTION	Peak (PK)
FREQUENCY RANGE	1GHz ~ 40GHz		Average (AV)

ANTENNA POLARITY & TEST DISTANCE: HORIZONTAL AT 3 M

FREQ. (MHz)	EMISSION LEVEL (dBuV/m)	READ LEVEL (dBuV)	LIMIT (dBuV/m)	MARGIN (dB)	ANTENNA FACTOR (dB /m)	CABLE LOSS (dB)	PREAMP FACTOR (dB)	ANTENNA HEIGHT (cm)	TABLE ANGLE (Degree)	REMARK
5150	58.14	59.81	74	-15.86	37.26	7.42	46.35	100	89	Peak
5150	47.98	49.65	54	-6.02	37.26	7.42	46.35	100	89	Average
5260	105.86	107.43			37.3	7.45	46.32	100	89	Peak
5260	95.28	96.85			37.3	7.45	46.32	100	89	Average
5350	58.9	60.39	74	-15.1	37.34	7.47	46.3	100	89	Peak
5350	48.69	50.18	54	-5.31	37.34	7.47	46.3	100	89	Average

ANTENNA POLARITY & TEST DISTANCE: VERTICAL AT 3 M

FREQ. (MHz)	EMISSION LEVEL (dBuV/m)	READ LEVEL (dBuV)	LIMIT (dBuV/m)	MARGIN (dB)	ANTENNA FACTOR (dB /m)	CABLE LOSS (dB)	PREAMP FACTOR (dB)	ANTENNA HEIGHT (cm)	TABLE ANGLE (Degree)	REMARK
5150	58.09	59.76	74	-15.91	37.26	7.42	46.35	100	85	Peak
5150	47.92	49.59	54	-6.08	37.26	7.42	46.35	100	85	Average
5260	105.01	106.58			37.3	7.45	46.32	100	85	Peak
5260	94.72	96.29			37.3	7.45	46.32	100	85	Average
5350	58.88	60.37	74	-15.12	37.34	7.47	46.3	100	85	Peak
5350	48.85	50.34	54	-5.15	37.34	7.47	46.3	100	85	Average

REMARKS:

- Emission Level = Read Level+ Antenna Factor + Cable Loss- Preamp Factor
Margin value = Emission level – Limit value.
- 5260MHz: Fundamental frequency.



CHANNEL	TX Channel 60	DETECTOR FUNCTION	Peak (PK)
FREQUENCY RANGE	1GHz ~ 40GHz		Average (AV)

ANTENNA POLARITY & TEST DISTANCE: HORIZONTAL AT 3 M

FREQ. (MHz)	EMISSION LEVEL (dBuV/m)	READ LEVEL (dBuV)	LIMIT (dBuV/m)	MARGIN (dB)	ANTENNA FACTOR (dB /m)	CABLE LOSS (dB)	PREAMP FACTOR (dB)	ANTENNA HEIGHT (cm)	TABLE ANGLE (Degree)	REMARK
5150	58.11	59.78	74	-15.89	37.26	7.42	46.35	100	159	Peak
5150	47.65	49.32	54	-6.35	37.26	7.42	46.35	100	159	Average
5300	105.36	106.89			37.32	7.46	46.31	100	159	Peak
5300	95.32	96.85			37.32	7.46	46.31	100	159	Average
5350	59.64	61.13	74	-14.36	37.34	7.47	46.3	100	159	Peak
5350	48.62	50.11	54	-5.38	37.34	7.47	46.3	100	159	Average

ANTENNA POLARITY & TEST DISTANCE: VERTICAL AT 3 M

FREQ. (MHz)	EMISSION LEVEL (dBuV/m)	READ LEVEL (dBuV)	LIMIT (dBuV/m)	MARGIN (dB)	ANTENNA FACTOR (dB /m)	CABLE LOSS (dB)	PREAMP FACTOR (dB)	ANTENNA HEIGHT (cm)	TABLE ANGLE (Degree)	REMARK
5150	58.01	59.68	74	-15.99	37.26	7.42	46.35	100	107	Peak
5150	48.65	50.32	54	-5.35	37.26	7.42	46.35	100	107	Average
5300	106.01	107.54			37.32	7.46	46.31	100	107	Peak
5300	95.25	96.78			37.32	7.46	46.31	100	107	Average
5350	58.82	60.31	74	-15.18	37.34	7.47	46.3	100	107	Peak
5350	48.65	50.14	54	-5.35	37.34	7.47	46.3	100	107	Average

REMARKS:

- Emission Level = Read Level+ Antenna Factor + Cable Loss- Preamp Factor
Margin value = Emission level – Limit value.
- 5300MHz: Fundamental frequency.



CHANNEL	TX Channel 64	DETECTOR FUNCTION	Peak (PK)
FREQUENCY RANGE	1GHz ~ 40GHz		Average (AV)

ANTENNA POLARITY & TEST DISTANCE: HORIZONTAL AT 3 M

FREQ. (MHz)	EMISSION LEVEL (dBuV/m)	READ LEVEL (dBuV)	LIMIT (dBuV/m)	MARGIN (dB)	ANTENNA FACTOR (dB /m)	CABLE LOSS (dB)	PREAMP FACTOR (dB)	ANTENNA HEIGHT (cm)	TABLE ANGLE (Degree)	REMARK
5150	58.78	60.45	74	-15.22	37.26	7.42	46.35	100	159	Peak
5150	49.05	50.72	54	-4.95	37.26	7.42	46.35	100	159	Average
5320	106.9	108.41			37.33	7.46	46.3	100	159	Peak
5320	97.69	99.2			37.33	7.46	46.3	100	159	Average
5350	62.04	63.53	74	-11.96	37.34	7.47	46.3	100	159	Peak
5350	50.15	51.64	54	-3.85	37.34	7.47	46.3	100	159	Average

ANTENNA POLARITY & TEST DISTANCE: VERTICAL AT 3 M

FREQ. (MHz)	EMISSION LEVEL (dBuV/m)	READ LEVEL (dBuV)	LIMIT (dBuV/m)	MARGIN (dB)	ANTENNA FACTOR (dB /m)	CABLE LOSS (dB)	PREAMP FACTOR (dB)	ANTENNA HEIGHT (cm)	TABLE ANGLE (Degree)	REMARK
5150	58.69	60.36	74	-15.31	37.26	7.42	46.35	100	107	Peak
5150	48.88	50.55	54	-5.12	37.26	7.42	46.35	100	107	Average
5320	105.94	107.45			37.33	7.46	46.3	100	107	Peak
5320	95.63	97.14			37.33	7.46	46.3	100	107	Average
5350	62.03	63.52	74	-11.97	37.34	7.47	46.3	100	107	Peak
5350	49.94	51.43	54	-4.06	37.34	7.47	46.3	100	107	Average

REMARKS:

- Emission Level = Read Level+ Antenna Factor + Cable Loss- Preamp Factor
Margin value = Emission level – Limit value.
- 5320MHz: Fundamental frequency.



802.11n (40MHz)

CHANNEL	TX Channel 54	DETECTOR FUNCTION	Peak (PK)
FREQUENCY RANGE	1GHz ~ 40GHz		Average (AV)

ANTENNA POLARITY & TEST DISTANCE: HORIZONTAL AT 3 M

FREQ. (MHz)	EMISSION LEVEL (dBuV/m)	READ LEVEL (dBuV)	LIMIT (dBuV/m)	MARGIN (dB)	ANTENNA FACTOR (dB /m)	CABLE LOSS (dB)	PREAMP FACTOR (dB)	ANTENNA HEIGHT (cm)	TABLE ANGLE (Degree)	REMARK
5150	58.82	60.49	74	-15.18	37.26	7.42	46.35	100	152	Peak
5150	48.16	49.83	54	-5.84	37.26	7.42	46.35	100	152	Average
5270	108.12	109.68			37.31	7.45	46.32	100	152	Peak
5270	98.29	99.85			37.31	7.45	46.32	100	152	Average
5350	58.89	60.38	74	-15.11	37.34	7.47	46.3	100	152	Peak
5350	48.66	50.15	54	-5.34	37.34	7.47	46.3	100	152	Average

ANTENNA POLARITY & TEST DISTANCE: VERTICAL AT 3 M

FREQ. (MHz)	EMISSION LEVEL (dBuV/m)	READ LEVEL (dBuV)	LIMIT (dBuV/m)	MARGIN (dB)	ANTENNA FACTOR (dB /m)	CABLE LOSS (dB)	PREAMP FACTOR (dB)	ANTENNA HEIGHT (cm)	TABLE ANGLE (Degree)	REMARK
5150	59.05	60.72	74	-14.95	37.26	7.42	46.35	100	0	Peak
5150	48.94	50.61	54	-5.06	37.26	7.42	46.35	100	0	Average
5270	108.87	110.43			37.31	7.45	46.32	100	0	Peak
5270	98.7	100.26			37.31	7.45	46.32	100	0	Average
5350	58.88	60.37	74	-15.12	37.34	7.47	46.3	100	0	Peak
5350	50.19	51.68	54	-3.81	37.34	7.47	46.3	100	0	Average

REMARKS:

- Emission Level = Read Level+ Antenna Factor + Cable Loss- Preamp Factor
Margin value = Emission level – Limit value.
- 5270MHz: Fundamental frequency.



CHANNEL	TX Channel 62	DETECTOR FUNCTION	Peak (PK)
FREQUENCY RANGE	1GHz ~ 40GHz		Average (AV)

ANTENNA POLARITY & TEST DISTANCE: HORIZONTAL AT 3 M										
FREQ. (MHz)	EMISSION LEVEL (dBuV/m)	READ LEVEL (dBuV)	LIMIT (dBuV/m)	MARGIN (dB)	ANTENNA FACTOR (dB /m)	CABLE LOSS (dB)	PREAMP FACTOR (dB)	ANTENNA HEIGHT (cm)	TABLE ANGLE (Degree)	REMARK
5150	58.48	60.15	74	-15.52	37.26	7.42	46.35	100	153	Peak
5150	48.71	50.38	54	-5.29	37.26	7.42	46.35	100	153	Average
5310	103.94	105.47			37.32	7.46	46.31	100	153	Peak
5310	93.72	95.25			37.32	7.46	46.31	100	153	Average
5350	67.4	68.89	74	-6.6	37.34	7.47	46.3	100	153	Peak
5350	50.52	52.01	54	-3.48	37.34	7.47	46.3	100	153	Average

ANTENNA POLARITY & TEST DISTANCE: VERTICAL AT 3 M										
FREQ. (MHz)	EMISSION LEVEL (dBuV/m)	READ LEVEL (dBuV)	LIMIT (dBuV/m)	MARGIN (dB)	ANTENNA FACTOR (dB /m)	CABLE LOSS (dB)	PREAMP FACTOR (dB)	ANTENNA HEIGHT (cm)	TABLE ANGLE (Degree)	REMARK
5150	58.87	60.54	74	-15.13	37.26	7.42	46.35	100	107	Peak
5150	48.22	49.89	54	-5.78	37.26	7.42	46.35	100	107	Average
5310	105.23	106.76			37.32	7.46	46.31	100	107	Peak
5310	95.07	96.6			37.32	7.46	46.31	100	107	Average
5350	66.02	67.51	74	-7.98	37.34	7.47	46.3	100	107	Peak
5350	50.13	51.62	54	-3.87	37.34	7.47	46.3	100	107	Average

REMARKS:

- Emission Level = Read Level+ Antenna Factor + Cable Loss- Preamp Factor
Margin value = Emission level – Limit value.
- 5310MHz: Fundamental frequency.



802.11ac (80MHz)

CHANNEL	TX Channel 58	DETECTOR FUNCTION	Peak (PK)
FREQUENCY RANGE	1GHz ~ 40GHz		Average (AV)

ANTENNA POLARITY & TEST DISTANCE: HORIZONTAL AT 3 M

FREQ. (MHz)	EMISSION LEVEL (dBuV/m)	READ LEVEL (dBuV)	LIMIT (dBuV/m)	MARGIN (dB)	ANTENNA FACTOR (dB /m)	CABLE LOSS (dB)	PREAMP FACTOR (dB)	ANTENNA HEIGHT (cm)	TABLE ANGLE (Degree)	REMARK
5150	58.61	60.28	74	-15.39	37.26	7.42	46.35	100	153	Peak
5150	48.02	49.69	54	-5.98	37.26	7.42	46.35	100	153	Average
5290	104.17	105.71			37.32	7.45	46.31	100	153	Peak
5290	93.92	95.46			37.32	7.45	46.31	100	153	Average
5350	61.96	63.45	74	-12.04	37.34	7.47	46.3	100	153	Peak
5350	49.99	51.48	54	-4.01	37.34	7.47	46.3	100	153	Average

ANTENNA POLARITY & TEST DISTANCE: VERTICAL AT 3 M

FREQ. (MHz)	EMISSION LEVEL (dBuV/m)	READ LEVEL (dBuV)	LIMIT (dBuV/m)	MARGIN (dB)	ANTENNA FACTOR (dB /m)	CABLE LOSS (dB)	PREAMP FACTOR (dB)	ANTENNA HEIGHT (cm)	TABLE ANGLE (Degree)	REMARK
5150	58.17	59.84	74	-15.83	37.26	7.42	46.35	100	96	Peak
5150	47.86	49.53	54	-6.14	37.26	7.42	46.35	100	96	Average
5290	104.1	105.64			37.32	7.45	46.31	100	96	Peak
5290	95.04	96.58			37.32	7.45	46.31	100	96	Average
5350	62.77	64.26	74	-11.23	37.34	7.47	46.3	100	96	Peak
5350	50.92	52.41	54	-3.08	37.34	7.47	46.3	100	96	Average

REMARKS:

- Emission Level = Read Level+ Antenna Factor + Cable Loss- Preamp Factor
Margin value = Emission level – Limit value.
- 5290MHz: Fundamental frequency.



Band 3

802.11a

CHANNEL	TX Channel 100	DETECTOR FUNCTION	Peak (PK)
FREQUENCY RANGE	1GHz ~ 40GHz		Average (AV)

ANTENNA POLARITY & TEST DISTANCE: HORIZONTAL AT 3 M

FREQ. (MHz)	EMISSION LEVEL (dBuV/m)	READ LEVEL (dBuV)	LIMIT (dBuV/m)	MARGIN (dB)	ANTENNA FACTOR (dB /m)	CABLE LOSS (dB)	PREAMP FACTOR (dB)	ANTENNA HEIGHT (cm)	TABLE ANGLE (Degree)	REMARK
5460	61.86	63.25	74	-12.14	37.38	7.49	46.26	100	151	Peak
5460	50.74	52.13	54	-3.26	37.38	7.49	46.26	100	151	Average
#5470	62.01	63.39	68.3	-6.29	37.39	7.49	46.26	100	151	Peak
5500	103.86	105.21			37.4	7.5	46.25	100	151	Peak
5500	93.52	94.87			37.4	7.5	46.25	100	151	Average

ANTENNA POLARITY & TEST DISTANCE: VERTICAL AT 3 M

FREQ. (MHz)	EMISSION LEVEL (dBuV/m)	READ LEVEL (dBuV)	LIMIT (dBuV/m)	MARGIN (dB)	ANTENNA FACTOR (dB /m)	CABLE LOSS (dB)	PREAMP FACTOR (dB)	ANTENNA HEIGHT (cm)	TABLE ANGLE (Degree)	REMARK
5460	62.09	63.48	74	-11.91	37.38	7.49	46.26	100	107	Peak
5460	49.95	51.34	54	-4.05	37.38	7.49	46.26	100	107	Average
#5470	62.23	63.61	68.3	-6.07	37.39	7.49	46.26	100	107	Peak
5500	103.89	105.24			37.4	7.5	46.25	100	107	Peak
5500	94.06	95.41			37.4	7.5	46.25	100	107	Average

REMARKS:

- Emission Level = Read Level+ Antenna Factor + Cable Loss- Preamp Factor
Margin value = Emission level – Limit value.
- 5500MHz: Fundamental frequency.
- #: Out of restricted band.



CHANNEL	TX Channel 116	DETECTOR FUNCTION	Peak (PK)
FREQUENCY RANGE	1GHz ~ 40GHz		Average (AV)

ANTENNA POLARITY & TEST DISTANCE: HORIZONTAL AT 3 M										
FREQ. (MHz)	EMISSION LEVEL (dBuV/m)	READ LEVEL (dBuV)	LIMIT (dBuV/m)	MARGIN (dB)	ANTENNA FACTOR (dB /m)	CABLE LOSS (dB)	PREAMP FACTOR (dB)	ANTENNA HEIGHT (cm)	TABLE ANGLE (Degree)	REMARK
5460	58.79	60.18	74	-15.21	37.38	7.49	46.26	100	86	Peak
5460	48.3	49.69	54	-5.7	37.38	7.49	46.26	100	86	Average
#5470	59.48	60.86	68.3	-8.82	37.39	7.49	46.26	100	86	Peak
5580	104.04	105.24			37.45	7.58	46.23	100	86	Peak
5580	93.42	94.62			37.45	7.58	46.23	100	86	Average

ANTENNA POLARITY & TEST DISTANCE: VERTICAL AT 3 M										
FREQ. (MHz)	EMISSION LEVEL (dBuV/m)	READ LEVEL (dBuV)	LIMIT (dBuV/m)	MARGIN (dB)	ANTENNA FACTOR (dB /m)	CABLE LOSS (dB)	PREAMP FACTOR (dB)	ANTENNA HEIGHT (cm)	TABLE ANGLE (Degree)	REMARK
5460	58.25	59.64	74	-15.75	37.38	7.49	46.26	100	75	Peak
5460	48.92	50.31	54	-5.08	37.38	7.49	46.26	100	75	Average
#5470	58.91	60.29	68.3	-9.39	37.39	7.49	46.26	100	75	Peak
5580	104.37	105.57			37.45	7.58	46.23	100	75	Peak
5580	94.22	95.42			37.45	7.58	46.23	100	75	Average

REMARKS:

- Emission Level = Read Level+ Antenna Factor + Cable Loss- Preamp Factor
Margin value = Emission level – Limit value.
- 5580MHz: Fundamental frequency.
- #: Out of restricted band.



CHANNEL	TX Channel 140	DETECTOR FUNCTION	Peak (PK)
FREQUENCY RANGE	1GHz ~ 40GHz		Average (AV)

ANTENNA POLARITY & TEST DISTANCE: HORIZONTAL AT 3 M										
FREQ. (MHz)	EMISSION LEVEL (dBuV/m)	READ LEVEL (dBuV)	LIMIT (dBuV/m)	MARGIN (dB)	ANTENNA FACTOR (dB /m)	CABLE LOSS (dB)	PREAMP FACTOR (dB)	ANTENNA HEIGHT (cm)	TABLE ANGLE (Degree)	REMARK
5700	108.81	109.78			37.52	7.7	46.19	102	92	Peak
5700	97.89	98.86			37.52	7.7	46.19	102	92	Average
#5725	63.66	64.59	68.3	-4.64	37.53	7.73	46.19	102	92	Peak
ANTENNA POLARITY & TEST DISTANCE: VERTICAL AT 3 M										
FREQ. (MHz)	EMISSION LEVEL (dBuV/m)	READ LEVEL (dBuV)	LIMIT (dBuV/m)	MARGIN (dB)	ANTENNA FACTOR (dB /m)	CABLE LOSS (dB)	PREAMP FACTOR (dB)	ANTENNA HEIGHT (cm)	TABLE ANGLE (Degree)	REMARK
5700	107.72	108.69			37.52	7.7	46.19	101	71	Peak
5700	96.55	97.52			37.52	7.7	46.19	101	71	Average
#5725	64.44	65.37	68.3	-3.86	37.53	7.73	46.19	101	71	Peak

REMARKS:

1. Emission Level = Read Level+ Antenna Factor + Cable Loss- Preamp Factor
Margin value = Emission level – Limit value.
2. 5700MHz: Fundamental frequency.
3. #: Out of restricted band.



802.11n (20MHz)

CHANNEL	TX Channel 100	DETECTOR FUNCTION	Peak (PK)
FREQUENCY RANGE	1GHz ~ 40GHz		Average (AV)

ANTENNA POLARITY & TEST DISTANCE: HORIZONTAL AT 3 M										
FREQ. (MHz)	EMISSION LEVEL (dBuV/m)	READ LEVEL (dBuV)	LIMIT (dBuV/m)	MARGIN (dB)	ANTENNA FACTOR (dB /m)	CABLE LOSS (dB)	PREAMP FACTOR (dB)	ANTENNA HEIGHT (cm)	TABLE ANGLE (Degree)	REMARK
5460	61.84	63.23	74	-12.16	37.38	7.49	46.26	100	148	Peak
5460	50.63	52.02	54	-3.37	37.38	7.49	46.26	100	148	Average
#5470	62.34	63.72	68.3	-5.96	37.39	7.49	46.26	100	148	Peak
5500	103.08	104.43			37.4	7.5	46.25	100	148	Peak
5500	92.26	93.61			37.4	7.5	46.25	100	148	Average

ANTENNA POLARITY & TEST DISTANCE: VERTICAL AT 3 M										
FREQ. (MHz)	EMISSION LEVEL (dBuV/m)	READ LEVEL (dBuV)	LIMIT (dBuV/m)	MARGIN (dB)	ANTENNA FACTOR (dB /m)	CABLE LOSS (dB)	PREAMP FACTOR (dB)	ANTENNA HEIGHT (cm)	TABLE ANGLE (Degree)	REMARK
5460	61.82	63.21	74	-12.18	37.38	7.49	46.26	100	107	Peak
5460	50.93	52.32	54	-3.07	37.38	7.49	46.26	100	107	Average
#5470	62.37	63.75	68.3	-5.93	37.39	7.49	46.26	100	107	Peak
5500	102.93	104.28			37.4	7.5	46.25	100	107	Peak
5500	92.54	93.89			37.4	7.5	46.25	100	107	Average

REMARKS:

- Emission Level = Read Level+ Antenna Factor + Cable Loss- Preamp Factor
Margin value = Emission level – Limit value.
- 5500MHz: Fundamental frequency.
- #: Out of restricted band.



CHANNEL	TX Channel 116	DETECTOR FUNCTION	Peak (PK)
FREQUENCY RANGE	1GHz ~ 40GHz		Average (AV)

ANTENNA POLARITY & TEST DISTANCE: HORIZONTAL AT 3 M										
FREQ. (MHz)	EMISSION LEVEL (dBuV/m)	READ LEVEL (dBuV)	LIMIT (dBuV/m)	MARGIN (dB)	ANTENNA FACTOR (dB /m)	CABLE LOSS (dB)	PREAMP FACTOR (dB)	ANTENNA HEIGHT (cm)	TABLE ANGLE (Degree)	REMARK
5460	58.92	60.31	74	-15.08	37.38	7.49	46.26	100	148	Peak
5460	48.17	49.56	54	-5.83	37.38	7.49	46.26	100	148	Average
#5470	59.11	60.49	68.3	-9.19	37.39	7.49	46.26	100	148	Peak
5580	102.96	104.16			37.45	7.58	46.23	100	148	Peak
5580	92.25	93.45			37.45	7.58	46.23	100	148	Average

ANTENNA POLARITY & TEST DISTANCE: VERTICAL AT 3 M										
FREQ. (MHz)	EMISSION LEVEL (dBuV/m)	READ LEVEL (dBuV)	LIMIT (dBuV/m)	MARGIN (dB)	ANTENNA FACTOR (dB /m)	CABLE LOSS (dB)	PREAMP FACTOR (dB)	ANTENNA HEIGHT (cm)	TABLE ANGLE (Degree)	REMARK
5460	58.5	59.89	74	-15.5	37.38	7.49	46.26	100	107	Peak
5460	48.29	49.68	54	-5.71	37.38	7.49	46.26	100	107	Average
#5470	58.99	60.37	68.3	-9.31	37.39	7.49	46.26	100	107	Peak
5580	103.53	104.73			37.45	7.58	46.23	100	107	Peak
5580	93.01	94.21			37.45	7.58	46.23	100	107	Average

REMARKS:

- Emission Level = Read Level+ Antenna Factor + Cable Loss- Preamp Factor
Margin value = Emission level – Limit value.
- 5580MHz: Fundamental frequency.
- #: Out of restricted band.



CHANNEL	TX Channel 140	DETECTOR FUNCTION	Peak (PK)
FREQUENCY RANGE	1GHz ~ 40GHz		Average (AV)

ANTENNA POLARITY & TEST DISTANCE: HORIZONTAL AT 3 M										
FREQ. (MHz)	EMISSION LEVEL (dBuV/m)	READ LEVEL (dBuV)	LIMIT (dBuV/m)	MARGIN (dB)	ANTENNA FACTOR (dB /m)	CABLE LOSS (dB)	PREAMP FACTOR (dB)	ANTENNA HEIGHT (cm)	TABLE ANGLE (Degree)	REMARK
5700	103.82	104.79			37.52	7.7	46.19	100	130	Peak
5700	93.38	94.35			37.52	7.7	46.19	100	130	Average
#5725	63.66	64.59	68.3	-4.64	37.53	7.73	46.19	100	130	Peak
ANTENNA POLARITY & TEST DISTANCE: VERTICAL AT 3 M										
FREQ. (MHz)	EMISSION LEVEL (dBuV/m)	READ LEVEL (dBuV)	LIMIT (dBuV/m)	MARGIN (dB)	ANTENNA FACTOR (dB /m)	CABLE LOSS (dB)	PREAMP FACTOR (dB)	ANTENNA HEIGHT (cm)	TABLE ANGLE (Degree)	REMARK
5700	104.17	105.14			37.52	7.7	46.19	100	107	Peak
5700	93.84	94.81			37.52	7.7	46.19	100	107	Average
#5725	63.35	64.28	68.3	-4.95	37.53	7.73	46.19	100	107	Peak

REMARKS:

- Emission Level = Read Level+ Antenna Factor + Cable Loss- Preamp Factor
Margin value = Emission level – Limit value.
- 5700MHz: Fundamental frequency.
- #: Out of restricted band.



802.11n (40MHz)

CHANNEL	TX Channel 102	DETECTOR FUNCTION	Peak (PK)
FREQUENCY RANGE	1GHz ~ 40GHz		Average (AV)

ANTENNA POLARITY & TEST DISTANCE: HORIZONTAL AT 3 M

FREQ. (MHz)	EMISSION LEVEL (dBuV/m)	READ LEVEL (dBuV)	LIMIT (dBuV/m)	MARGIN (dB)	ANTENNA FACTOR (dB /m)	CABLE LOSS (dB)	PREAMP FACTOR (dB)	ANTENNA HEIGHT (cm)	TABLE ANGLE (Degree)	REMARK
5460	64.82	66.21	74	-9.18	37.38	7.49	46.26	100	149	Peak
5460	50.62	52.01	54	-3.38	37.38	7.49	46.26	100	149	Average
#5470	65.07	66.45	68.3	-3.23	37.39	7.49	46.26	100	149	Peak
5510	104.32	105.65			37.41	7.51	46.25	100	149	Peak
5510	93.99	95.32			37.41	7.51	46.25	100	149	Average

ANTENNA POLARITY & TEST DISTANCE: VERTICAL AT 3 M

FREQ. (MHz)	EMISSION LEVEL (dBuV/m)	READ LEVEL (dBuV)	LIMIT (dBuV/m)	MARGIN (dB)	ANTENNA FACTOR (dB /m)	CABLE LOSS (dB)	PREAMP FACTOR (dB)	ANTENNA HEIGHT (cm)	TABLE ANGLE (Degree)	REMARK
5460	65.04	66.43	74	-8.96	37.38	7.49	46.26	100	105	Peak
5460	50.86	52.25	54	-3.14	37.38	7.49	46.26	100	105	Average
#5470	64.49	65.87	68.3	-3.81	37.39	7.49	46.26	100	105	Peak
5510	103.9	105.23			37.41	7.51	46.25	100	105	Peak
5510	93.28	94.61			37.41	7.51	46.25	100	105	Average

REMARKS:

- Emission Level = Read Level+ Antenna Factor + Cable Loss- Preamp Factor
Margin value = Emission level – Limit value.
- 5510MHz: Fundamental frequency.
- #: Out of restricted band.



CHANNEL	TX Channel 110	DETECTOR FUNCTION	Peak (PK)
FREQUENCY RANGE	1GHz ~ 40GHz		Average (AV)

ANTENNA POLARITY & TEST DISTANCE: HORIZONTAL AT 3 M										
FREQ. (MHz)	EMISSION LEVEL (dBuV/m)	READ LEVEL (dBuV)	LIMIT (dBuV/m)	MARGIN (dB)	ANTENNA FACTOR (dB /m)	CABLE LOSS (dB)	PREAMP FACTOR (dB)	ANTENNA HEIGHT (cm)	TABLE ANGLE (Degree)	REMARK
5460	59.06	60.45	74	-14.94	37.38	7.49	46.26	100	146	Peak
5460	48.92	50.31	54	-5.08	37.38	7.49	46.26	100	146	Average
#5470	59.94	61.32	68.3	-8.36	37.39	7.49	46.26	100	146	Peak
5550	104.22	105.48			37.43	7.55	46.24	100	146	Peak
5550	93.01	94.27			37.43	7.55	46.24	100	146	Average

ANTENNA POLARITY & TEST DISTANCE: VERTICAL AT 3 M										
FREQ. (MHz)	EMISSION LEVEL (dBuV/m)	READ LEVEL (dBuV)	LIMIT (dBuV/m)	MARGIN (dB)	ANTENNA FACTOR (dB /m)	CABLE LOSS (dB)	PREAMP FACTOR (dB)	ANTENNA HEIGHT (cm)	TABLE ANGLE (Degree)	REMARK
5460	59.18	60.57	74	-14.82	37.38	7.49	46.26	100	100	Peak
5460	49.07	50.46	54	-4.93	37.38	7.49	46.26	100	100	Average
#5470	59.65	61.03	68.3	-8.65	37.39	7.49	46.26	100	100	Peak
5550	104.24	105.5			37.43	7.55	46.24	100	100	Peak
5550	94.42	95.68			37.43	7.55	46.24	100	100	Average

REMARKS:

- Emission Level = Read Level+ Antenna Factor + Cable Loss- Preamp Factor
Margin value = Emission level – Limit value.
- 5550MHz: Fundamental frequency.
- #: Out of restricted band.



CHANNEL	TX Channel 134	DETECTOR FUNCTION	Peak (PK)
FREQUENCY RANGE	1GHz ~ 40GHz		Average (AV)

ANTENNA POLARITY & TEST DISTANCE: HORIZONTAL AT 3 M										
FREQ. (MHz)	EMISSION LEVEL (dBuV/m)	READ LEVEL (dBuV)	LIMIT (dBuV/m)	MARGIN (dB)	ANTENNA FACTOR (dB /m)	CABLE LOSS (dB)	PREAMP FACTOR (dB)	ANTENNA HEIGHT (cm)	TABLE ANGLE (Degree)	REMARK
5670	103.26	104.29			37.5	7.67	46.2	100	218	Peak
5670	93.1	94.13			37.5	7.67	46.2	100	218	Average
#5725	64.29	65.22	68.3	-4.01	37.53	7.73	46.19	100	218	Peak
ANTENNA POLARITY & TEST DISTANCE: VERTICAL AT 3 M										
FREQ. (MHz)	EMISSION LEVEL (dBuV/m)	READ LEVEL (dBuV)	LIMIT (dBuV/m)	MARGIN (dB)	ANTENNA FACTOR (dB /m)	CABLE LOSS (dB)	PREAMP FACTOR (dB)	ANTENNA HEIGHT (cm)	TABLE ANGLE (Degree)	REMARK
5670	104.38	105.41			37.5	7.67	46.2	100	101	Peak
5670	93.82	94.85			37.5	7.67	46.2	100	101	Average
#5725	63.63	64.56	68.3	-4.67	37.53	7.73	46.19	100	101	Peak

REMARKS:

- Emission Level = Read Level+ Antenna Factor + Cable Loss- Preamp Factor
Margin value = Emission level – Limit value.
- 5670MHz: Fundamental frequency.
- #: Out of restricted band.



802.11ac (80MHz)

CHANNEL	TX Channel 106	DETECTOR FUNCTION	Peak (PK)
FREQUENCY RANGE	1GHz ~ 40GHz		Average (AV)

ANTENNA POLARITY & TEST DISTANCE: HORIZONTAL AT 3 M										
FREQ. (MHz)	EMISSION LEVEL (dBuV/m)	READ LEVEL (dBuV)	LIMIT (dBuV/m)	MARGIN (dB)	ANTENNA FACTOR (dB /m)	CABLE LOSS (dB)	PREAMP FACTOR (dB)	ANTENNA HEIGHT (cm)	TABLE ANGLE (Degree)	REMARK
5460	63.14	64.53	74	-10.86	37.38	7.49	46.26	100	204	Peak
5460	50.73	52.12	54	-3.27	37.38	7.49	46.26	100	204	Average
#5470	64.4	65.78	68.3	-3.9	37.39	7.49	46.26	100	204	Peak
5530	103.23	104.52			37.42	7.53	46.24	100	204	Peak
5530	92.39	93.68			37.42	7.53	46.24	100	204	Average

ANTENNA POLARITY & TEST DISTANCE: VERTICAL AT 3 M										
FREQ. (MHz)	EMISSION LEVEL (dBuV/m)	READ LEVEL (dBuV)	LIMIT (dBuV/m)	MARGIN (dB)	ANTENNA FACTOR (dB /m)	CABLE LOSS (dB)	PREAMP FACTOR (dB)	ANTENNA HEIGHT (cm)	TABLE ANGLE (Degree)	REMARK
5460	62.96	64.35	74	-11.04	37.38	7.49	46.26	100	101	Peak
5460	50.64	52.03	54	-3.36	37.38	7.49	46.26	100	101	Average
#5470	62.78	64.16	68.3	-5.52	37.39	7.49	46.26	100	101	Peak
5530	103.29	104.58			37.42	7.53	46.24	100	101	Peak
5530	92.97	94.26			37.42	7.53	46.24	100	101	Average

REMARKS:

- Emission Level = Read Level+ Antenna Factor + Cable Loss- Preamp Factor
Margin value = Emission level – Limit value.
- 5530MHz: Fundamental frequency.
- #: Out of restricted band.



Band 4

802.11a

CHANNEL	TX Channel 149	DETECTOR FUNCTION	Peak (PK)
FREQUENCY RANGE	1GHz ~ 40GHz		Average (AV)

ANTENNA POLARITY & TEST DISTANCE: HORIZONTAL AT 3 M										
FREQ. (MHz)	EMISSION LEVEL (dBuV/m)	READ LEVEL (dBuV)	LIMIT (dBuV/m)	MARGIN (dB)	ANTENNA FACTOR (dB /m)	CABLE LOSS (dB)	PREAMP FACTOR (dB)	ANTENNA HEIGHT (cm)	TABLE ANGLE (Degree)	REMARK
5745	105.73	106.61			37.55	7.75	46.18	100	311	Peak
5745	95.2	96.08			37.55	7.75	46.18	100	311	Average
ANTENNA POLARITY & TEST DISTANCE: VERTICAL AT 3 M										
FREQ. (MHz)	EMISSION LEVEL (dBuV/m)	READ LEVEL (dBuV)	LIMIT (dBuV/m)	MARGIN (dB)	ANTENNA FACTOR (dB /m)	CABLE LOSS (dB)	PREAMP FACTOR (dB)	ANTENNA HEIGHT (cm)	TABLE ANGLE (Degree)	REMARK
5745	108.11	108.99			37.55	7.75	46.18	100	125	Peak
5745	95.99	96.87			37.55	7.75	46.18	100	125	Average

REMARKS:

- Emission Level = Read Level+ Antenna Factor + Cable Loss- Preamp Factor
Margin value = Emission level – Limit value.
- 5745MHz: Fundamental frequency.



Oobe Data

802.11a

ANTENNA POLARITY & TEST DISTANCE: HORIZONTAL AT 3 M										
FREQ. (MHz)	EMISSION LEVEL (dBuV/m)	READ LEVEL (dBuV)	LIMIT (dBuV/m)	MARGIN (dB)	ANTENNA FACTOR (dB /m)	CABLE LOSS (dB)	PREAMP FACTOR (dB)	ANTENNA HEIGHT (cm)	TABLE ANGLE (Degree)	REMARK
5561.40	58.58	59.81	68.3	-9.72	37.44	7.56	46.23	200	360	Peak
5988.43	59.86	60.28	68.3	-8.44	37.69	8	46.11	200	360	Peak
ANTENNA POLARITY & TEST DISTANCE: VERTICAL AT 3 M										
FREQ. (MHz)	EMISSION LEVEL (dBuV/m)	READ LEVEL (dBuV)	LIMIT (dBuV/m)	MARGIN (dB)	ANTENNA FACTOR (dB /m)	CABLE LOSS (dB)	PREAMP FACTOR (dB)	ANTENNA HEIGHT (cm)	TABLE ANGLE (Degree)	REMARK
5568.05	59.21	60.43	68.3	-9.09	37.44	7.57	46.23	100	360	Peak
6006	59.15	59.56	68.3	-9.15	37.7	8	46.11	100	360	Peak

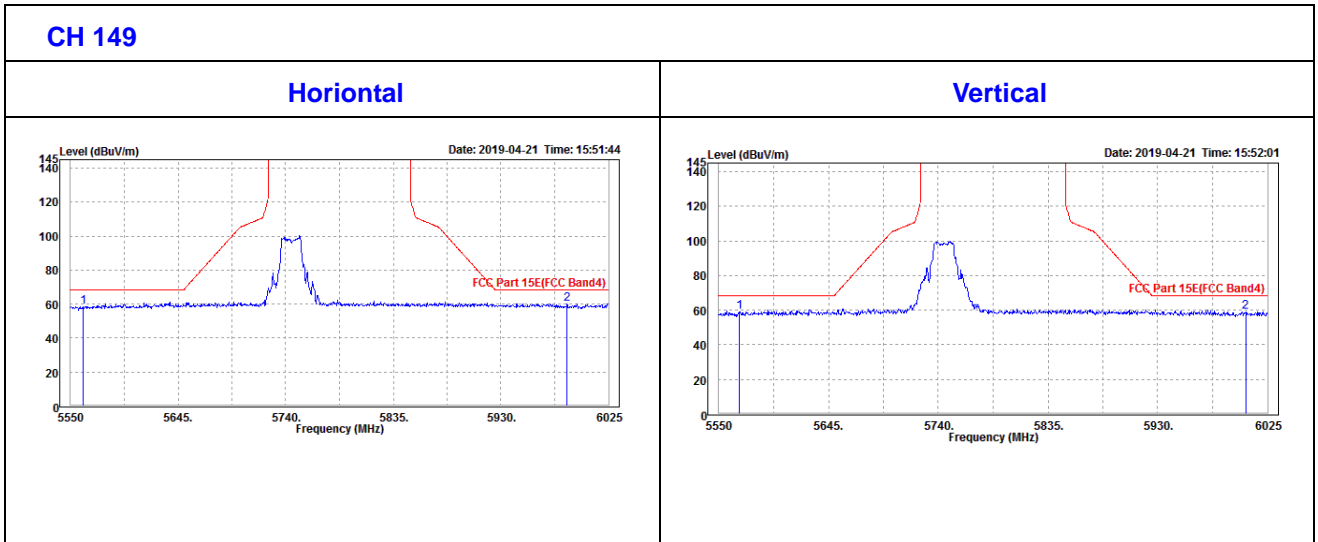



CHANNEL	TX Channel 157	DETECTOR FUNCTION	Peak (PK)
FREQUENCY RANGE	1GHz ~ 40GHz		Average (AV)

ANTENNA POLARITY & TEST DISTANCE: HORIZONTAL AT 3 M										
FREQ. (MHz)	EMISSION LEVEL (dBuV/m)	READ LEVEL (dBuV)	LIMIT (dBuV/m)	MARGIN (dB)	ANTENNA FACTOR (dB /m)	CABLE LOSS (dB)	PREAMP FACTOR (dB)	ANTENNA HEIGHT (cm)	TABLE ANGLE (Degree)	REMARK
5785	104.51	105.32			37.57	7.79	46.17	100	172	Peak
5785	94.61	95.42			37.57	7.79	46.17	100	172	Average

ANTENNA POLARITY & TEST DISTANCE: VERTICAL AT 3 M										
FREQ. (MHz)	EMISSION LEVEL (dBuV/m)	READ LEVEL (dBuV)	LIMIT (dBuV/m)	MARGIN (dB)	ANTENNA FACTOR (dB /m)	CABLE LOSS (dB)	PREAMP FACTOR (dB)	ANTENNA HEIGHT (cm)	TABLE ANGLE (Degree)	REMARK
5785	103.95	105.66			36.67	7.79	46.17	152	323	Peak
5785	94.7	96.41			36.67	7.79	46.17	152	323	Average

REMARKS:

1. Emission Level = Read Level+ Antenna Factor + Cable Loss- Preamp Factor
Margin value = Emission level – Limit value.
2. 5785MHz: Fundamental frequency.



Oobe Data

802.11a

ANTENNA POLARITY & TEST DISTANCE: HORIZONTAL AT 3 M										
FREQ. (MHz)	EMISSION LEVEL (dBuV/m)	READ LEVEL (dBuV)	LIMIT (dBuV/m)	MARGIN (dB)	ANTENNA FACTOR (dB /m)	CABLE LOSS (dB)	PREAMP FACTOR (dB)	ANTENNA HEIGHT (cm)	TABLE ANGLE (Degree)	REMARK
5567.1	58.38	59.6	68.3	-9.92	37.44	7.57	46.23	100	360	Peak
5968.95	60.27	60.73	68.3	-8.03	37.68	7.98	46.12	100	360	Peak
ANTENNA POLARITY & TEST DISTANCE: VERTICAL AT 3 M										
FREQ. (MHz)	EMISSION LEVEL (dBuV/m)	READ LEVEL (dBuV)	LIMIT (dBuV/m)	MARGIN (dB)	ANTENNA FACTOR (dB /m)	CABLE LOSS (dB)	PREAMP FACTOR (dB)	ANTENNA HEIGHT (cm)	TABLE ANGLE (Degree)	REMARK
5587.53	58.33	59.52	68.3	-9.97	37.45	7.59	46.23	100	0	Peak
5974.18	57.5	57.96	68.3	-10.8	37.68	7.98	46.12	100	0	Peak

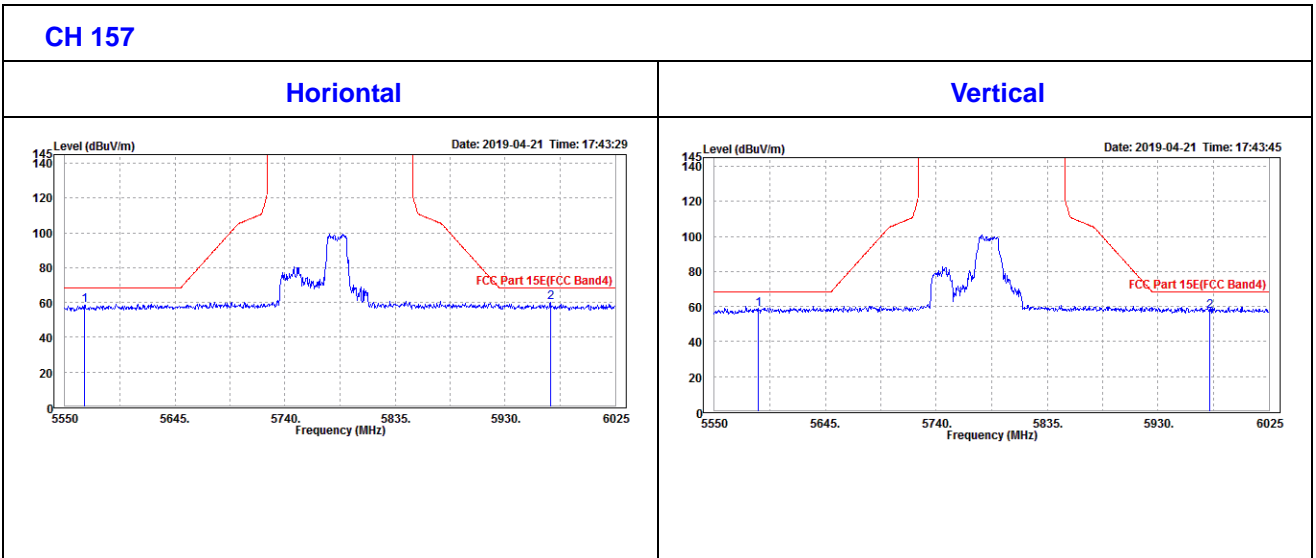



CHANNEL	TX Channel 165	DETECTOR FUNCTION	Peak (PK)
FREQUENCY RANGE	1GHz ~ 40GHz		Average (AV)

ANTENNA POLARITY & TEST DISTANCE: HORIZONTAL AT 3 M										
FREQ. (MHz)	EMISSION LEVEL (dBuV/m)	READ LEVEL (dBuV)	LIMIT (dBuV/m)	MARGIN (dB)	ANTENNA FACTOR (dB /m)	CABLE LOSS (dB)	PREAMP FACTOR (dB)	ANTENNA HEIGHT (cm)	TABLE ANGLE (Degree)	REMARK
5825	104.39	105.12			37.6	7.83	46.16	100	305	Peak
5825	93.89	94.62			37.6	7.83	46.16	100	305	Average

ANTENNA POLARITY & TEST DISTANCE: VERTICAL AT 3 M										
FREQ. (MHz)	EMISSION LEVEL (dBuV/m)	READ LEVEL (dBuV)	LIMIT (dBuV/m)	MARGIN (dB)	ANTENNA FACTOR (dB /m)	CABLE LOSS (dB)	PREAMP FACTOR (dB)	ANTENNA HEIGHT (cm)	TABLE ANGLE (Degree)	REMARK
5825	105.52	106.25			37.6	7.83	46.16	104	68	Peak
5825	95.4	96.13			37.6	7.83	46.16	104	68	Average

REMARKS:

1. Emission Level = Read Level+ Antenna Factor + Cable Loss- Preamp Factor
Margin value = Emission level – Limit value.
2. 5825MHz: Fundamental frequency.



Oobe Data

802.11a

ANTENNA POLARITY & TEST DISTANCE: HORIZONTAL AT 3 M										
FREQ. (MHz)	EMISSION LEVEL (dBuV/m)	READ LEVEL (dBuV)	LIMIT (dBuV/m)	MARGIN (dB)	ANTENNA FACTOR (dB /m)	CABLE LOSS (dB)	PREAMP FACTOR (dB)	ANTENNA HEIGHT (cm)	TABLE ANGLE (Degree)	REMARK
5578.5	56.92	58.12	68.3	-11.38	37.45	7.58	46.23	100	0	Peak
5979.88	57.74	58.18	68.3	-10.56	37.69	7.99	46.12	100	0	Peak
ANTENNA POLARITY & TEST DISTANCE: VERTICAL AT 3 M										
FREQ. (MHz)	EMISSION LEVEL (dBuV/m)	READ LEVEL (dBuV)	LIMIT (dBuV/m)	MARGIN (dB)	ANTENNA FACTOR (dB /m)	CABLE LOSS (dB)	PREAMP FACTOR (dB)	ANTENNA HEIGHT (cm)	TABLE ANGLE (Degree)	REMARK
5576.6	58.05	59.25	68.3	-10.25	37.45	7.58	46.23	100	360	Peak
5985.1	57.64	58.07	68.3	-10.66	37.69	7.99	46.11	100	360	Peak

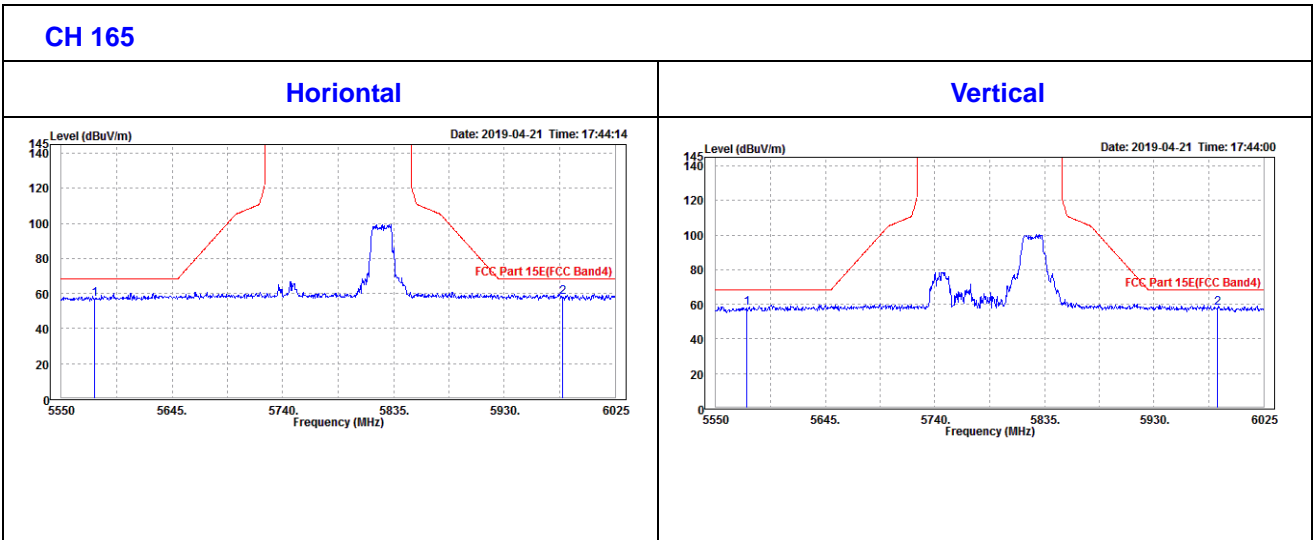



802.11n (20MHz)

CHANNEL	TX Channel 149	DETECTOR FUNCTION	Peak (PK)
FREQUENCY RANGE	1GHz ~ 40GHz		Average (AV)

ANTENNA POLARITY & TEST DISTANCE: HORIZONTAL AT 3 M										
FREQ. (MHz)	EMISSION LEVEL (dBuV/m)	READ LEVEL (dBuV)	LIMIT (dBuV/m)	MARGIN (dB)	ANTENNA FACTOR (dB /m)	CABLE LOSS (dB)	PREAMP FACTOR (dB)	ANTENNA HEIGHT (cm)	TABLE ANGLE (Degree)	REMARK
5745	105.57	106.45			37.55	7.75	46.18	100	342	Peak
5745	94.74	95.62			37.55	7.75	46.18	100	342	Average
ANTENNA POLARITY & TEST DISTANCE: VERTICAL AT 3 M										
FREQ. (MHz)	EMISSION LEVEL (dBuV/m)	READ LEVEL (dBuV)	LIMIT (dBuV/m)	MARGIN (dB)	ANTENNA FACTOR (dB /m)	CABLE LOSS (dB)	PREAMP FACTOR (dB)	ANTENNA HEIGHT (cm)	TABLE ANGLE (Degree)	REMARK
5745	106.24	107.12			37.55	7.75	46.18	100	23	Peak
5745	95.47	96.35			37.55	7.75	46.18	100	23	Average

REMARKS:

1. Emission Level = Read Level+ Antenna Factor + Cable Loss- Preamp Factor
Margin value = Emission level – Limit value.
2. 5745MHz: Fundamental frequency.



OUBE DATA

802.11n (20MHZ)

ANTENNA POLARITY & TEST DISTANCE: HORIZONTAL AT 3 M										
FREQ. (MHz)	EMISSION LEVEL (dBuV/m)	READ LEVEL (dBuV)	LIMIT (dBuV/m)	MARGIN (dB)	ANTENNA FACTOR (dB /m)	CABLE LOSS (dB)	PREAMP FACTOR (dB)	ANTENNA HEIGHT (cm)	TABLE ANGLE (Degree)	REMARK
5570.9	56.41	57.63	68.3	-11.89	37.44	7.57	46.23	100	0	Peak
5976.55	57.34	57.78	68.3	-10.96	37.69	7.99	46.12	100	0	Peak
ANTENNA POLARITY & TEST DISTANCE: VERTICAL AT 3 M										
FREQ. (MHz)	EMISSION LEVEL (dBuV/m)	READ LEVEL (dBuV)	LIMIT (dBuV/m)	MARGIN (dB)	ANTENNA FACTOR (dB /m)	CABLE LOSS (dB)	PREAMP FACTOR (dB)	ANTENNA HEIGHT (cm)	TABLE ANGLE (Degree)	REMARK
5576.13	54.84	56.94	68.3	-13.46	36.55	7.58	46.23	100	360	Peak
5982.73	57.31	58.64	68.3	-10.99	36.79	7.99	46.11	100	360	Peak

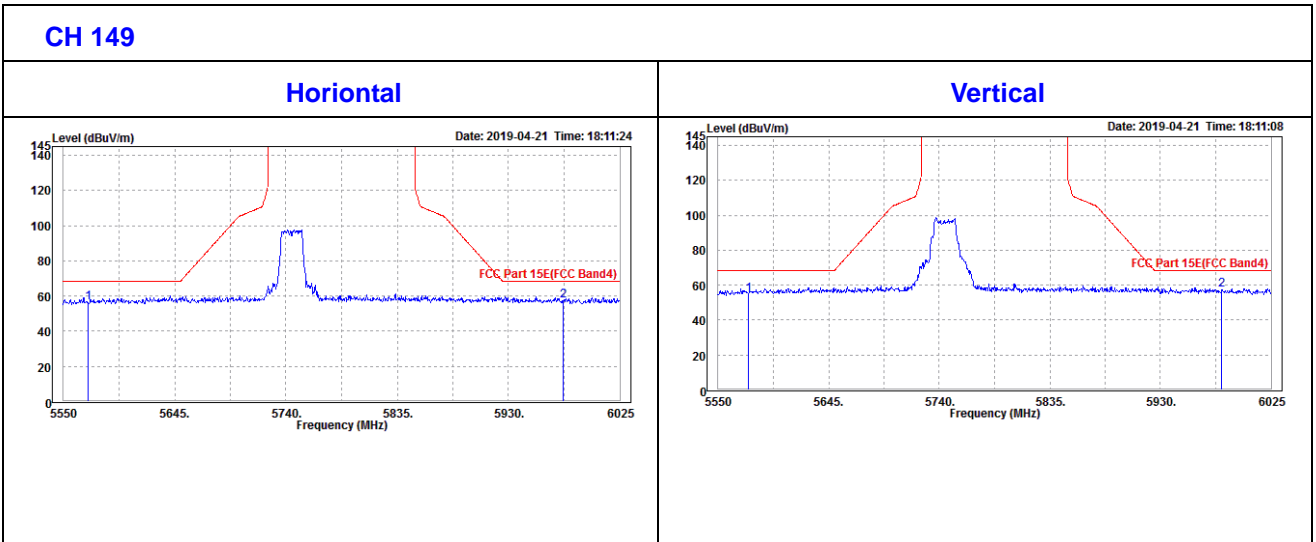



CHANNEL	TX Channel 157	DETECTOR FUNCTION	Peak (PK)
FREQUENCY RANGE	1GHz ~ 40GHz		Average (AV)

ANTENNA POLARITY & TEST DISTANCE: HORIZONTAL AT 3 M										
FREQ. (MHz)	EMISSION LEVEL (dBuV/m)	READ LEVEL (dBuV)	LIMIT (dBuV/m)	MARGIN (dB)	ANTENNA FACTOR (dB /m)	CABLE LOSS (dB)	PREAMP FACTOR (dB)	ANTENNA HEIGHT (cm)	TABLE ANGLE (Degree)	REMARK
5785	106.14	106.95			37.57	7.79	46.17	100	177	Peak
5785	94.06	94.87			37.57	7.79	46.17	100	177	Average

ANTENNA POLARITY & TEST DISTANCE: VERTICAL AT 3 M										
FREQ. (MHz)	EMISSION LEVEL (dBuV/m)	READ LEVEL (dBuV)	LIMIT (dBuV/m)	MARGIN (dB)	ANTENNA FACTOR (dB /m)	CABLE LOSS (dB)	PREAMP FACTOR (dB)	ANTENNA HEIGHT (cm)	TABLE ANGLE (Degree)	REMARK
5785	103.71	105.42			36.67	7.79	46.17	148	315	Peak
5785	92.97	94.68			36.67	7.79	46.17	148	315	Average

REMARKS:

1. Emission Level = Read Level+ Antenna Factor + Cable Loss- Preamp Factor
Margin value = Emission level – Limit value.
2. 5785MHz: Fundamental frequency.



Oobe Data

802.11n (20MHz)

ANTENNA POLARITY & TEST DISTANCE: HORIZONTAL AT 3 M										
FREQ. (MHz)	EMISSION LEVEL (dBuV/m)	READ LEVEL (dBuV)	LIMIT (dBuV/m)	MARGIN (dB)	ANTENNA FACTOR (dB /m)	CABLE LOSS (dB)	PREAMP FACTOR (dB)	ANTENNA HEIGHT (cm)	TABLE ANGLE (Degree)	REMARK
5581.83	56.95	58.15	68.3	-11.35	37.45	7.58	46.23	100	0	Peak
5985.58	56.42	56.84	68.3	-11.88	37.69	8	46.11	100	0	Peak
ANTENNA POLARITY & TEST DISTANCE: VERTICAL AT 3 M										
FREQ. (MHz)	EMISSION LEVEL (dBuV/m)	READ LEVEL (dBuV)	LIMIT (dBuV/m)	MARGIN (dB)	ANTENNA FACTOR (dB /m)	CABLE LOSS (dB)	PREAMP FACTOR (dB)	ANTENNA HEIGHT (cm)	TABLE ANGLE (Degree)	REMARK
5577.08	57.74	58.94	68.3	-10.56	37.45	7.58	46.23	100	360	Peak
5976.08	58.41	58.85	68.3	-9.89	37.69	7.99	46.12	100	360	Peak

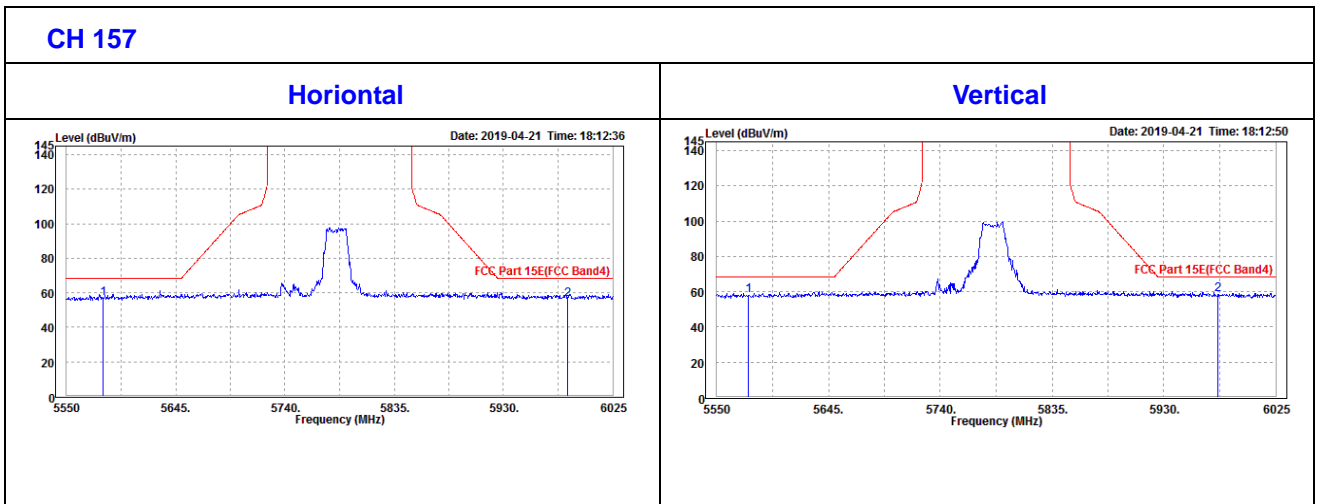



CHANNEL	TX Channel 165	DETECTOR FUNCTION	Peak (PK)
FREQUENCY RANGE	1GHz ~ 40GHz		Average (AV)

ANTENNA POLARITY & TEST DISTANCE: HORIZONTAL AT 3 M										
FREQ. (MHz)	EMISSION LEVEL (dBuV/m)	READ LEVEL (dBuV)	LIMIT (dBuV/m)	MARGIN (dB)	ANTENNA FACTOR (dB /m)	CABLE LOSS (dB)	PREAMP FACTOR (dB)	ANTENNA HEIGHT (cm)	TABLE ANGLE (Degree)	REMARK
5825	104.42	105.15			37.6	7.83	46.16	100	304	Peak
5825	93.58	94.31			37.6	7.83	46.16	100	304	Average

ANTENNA POLARITY & TEST DISTANCE: VERTICAL AT 3 M										
FREQ. (MHz)	EMISSION LEVEL (dBuV/m)	READ LEVEL (dBuV)	LIMIT (dBuV/m)	MARGIN (dB)	ANTENNA FACTOR (dB /m)	CABLE LOSS (dB)	PREAMP FACTOR (dB)	ANTENNA HEIGHT (cm)	TABLE ANGLE (Degree)	REMARK
5825	105.72	106.45			37.6	7.83	46.16	108	79	Peak
5825	94.5	95.23			37.6	7.83	46.16	108	79	Average

REMARKS:

- Emission Level = Read Level+ Antenna Factor + Cable Loss- Preamp Factor
Margin value = Emission level – Limit value.
- 5825MHz: Fundamental frequency.



OUBE DATA

802.11n (20MHZ)

ANTENNA POLARITY & TEST DISTANCE: HORIZONTAL AT 3 M										
FREQ. (MHz)	EMISSION LEVEL (dBuV/m)	READ LEVEL (dBuV)	LIMIT (dBuV/m)	MARGIN (dB)	ANTENNA FACTOR (dB /m)	CABLE LOSS (dB)	PREAMP FACTOR (dB)	ANTENNA HEIGHT (cm)	TABLE ANGLE (Degree)	REMARK
5570.43	58.05	59.27	68.3	-10.25	37.44	7.57	46.23	100	360	Peak
5995.08	57.19	57.6	68.3	-11.11	37.7	8	46.11	100	360	Peak
ANTENNA POLARITY & TEST DISTANCE: VERTICAL AT 3 M										
FREQ. (MHz)	EMISSION LEVEL (dBuV/m)	READ LEVEL (dBuV)	LIMIT (dBuV/m)	MARGIN (dB)	ANTENNA FACTOR (dB /m)	CABLE LOSS (dB)	PREAMP FACTOR (dB)	ANTENNA HEIGHT (cm)	TABLE ANGLE (Degree)	REMARK
5586.58	58.84	60.03	68.3	-9.46	37.45	7.59	46.23	100	0	Peak
5962.30	58.23	58.7	68.3	-10.07	37.68	7.97	46.12	100	0	Peak

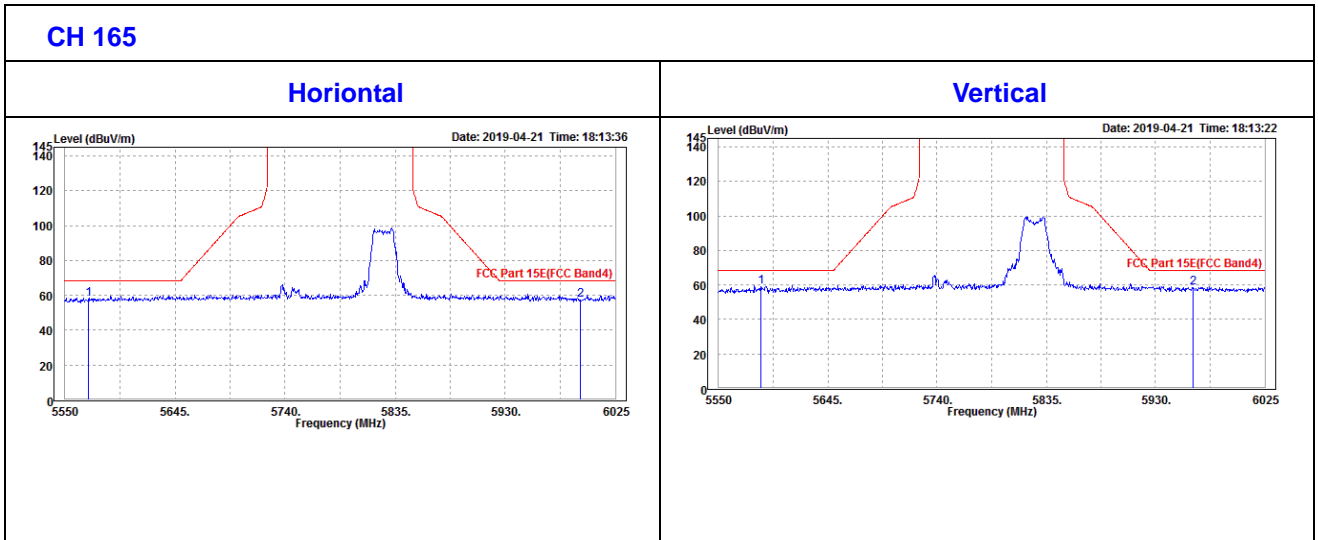



802.11n (40MHz)

CHANNEL	TX Channel 151	DETECTOR FUNCTION	Peak (PK)
FREQUENCY RANGE	1GHz ~ 40GHz		Average (AV)

ANTENNA POLARITY & TEST DISTANCE: HORIZONTAL AT 3 M										
FREQ. (MHz)	EMISSION LEVEL (dBuV/m)	READ LEVEL (dBuV)	LIMIT (dBuV/m)	MARGIN (dB)	ANTENNA FACTOR (dB /m)	CABLE LOSS (dB)	PREAMP FACTOR (dB)	ANTENNA HEIGHT (cm)	TABLE ANGLE (Degree)	REMARK
5755	104.42	105.29			37.55	7.76	46.18	100	309	Peak
5755	93.71	94.58			37.55	7.76	46.18	100	309	Average
ANTENNA POLARITY & TEST DISTANCE: VERTICAL AT 3 M										
FREQ. (MHz)	EMISSION LEVEL (dBuV/m)	READ LEVEL (dBuV)	LIMIT (dBuV/m)	MARGIN (dB)	ANTENNA FACTOR (dB /m)	CABLE LOSS (dB)	PREAMP FACTOR (dB)	ANTENNA HEIGHT (cm)	TABLE ANGLE (Degree)	REMARK
5755	102.82	104.59			36.65	7.76	46.18	183	321	Peak
5755	91.87	93.64			36.65	7.76	46.18	183	321	Average

REMARKS:

1. Emission Level = Read Level+ Antenna Factor + Cable Loss- Preamp Factor
Margin value = Emission level – Limit value.
2. 5755MHz: Fundamental frequency.



**BUREAU
VERITAS**

Test Report No.: RF190326W003-3

OUBE DATA

802.11n (40MHZ)

ANTENNA POLARITY & TEST DISTANCE: HORIZONTAL AT 3 M										
FREQ. (MHz)	EMISSION LEVEL (dBuV/m)	READ LEVEL (dBuV)	LIMIT (dBuV/m)	MARGIN (dB)	ANTENNA FACTOR (dB /m)	CABLE LOSS (dB)	PREAMP FACTOR (dB)	ANTENNA HEIGHT (cm)	TABLE ANGLE (Degree)	REMARK
5587.05	56.99	58.18	68.3	-11.31	37.45	7.59	46.23	100	0	Peak
5968	58.26	58.72	68.3	-10.04	37.68	7.98	46.12	100	0	Peak
ANTENNA POLARITY & TEST DISTANCE: VERTICAL AT 3 M										
FREQ. (MHz)	EMISSION LEVEL (dBuV/m)	READ LEVEL (dBuV)	LIMIT (dBuV/m)	MARGIN (dB)	ANTENNA FACTOR (dB /m)	CABLE LOSS (dB)	PREAMP FACTOR (dB)	ANTENNA HEIGHT (cm)	TABLE ANGLE (Degree)	REMARK
5601.30	56.24	57.4	68.3	-12.06	37.46	7.6	46.22	100	360	Peak
5969.43	58.03	58.49	68.3	-10.27	37.68	7.98	46.12	100	360	Peak

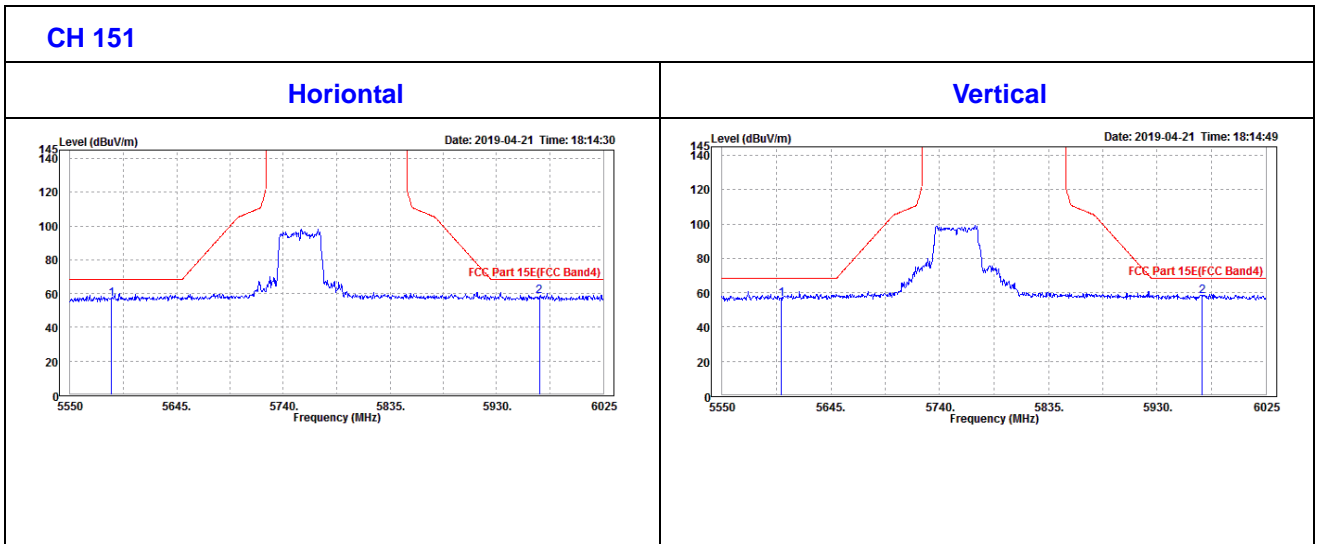



CHANNEL	TX Channel 159	DETECTOR FUNCTION	Peak (PK)
FREQUENCY RANGE	1GHz ~ 40GHz		Average (AV)

ANTENNA POLARITY & TEST DISTANCE: HORIZONTAL AT 3 M										
FREQ. (MHz)	EMISSION LEVEL (dBuV/m)	READ LEVEL (dBuV)	LIMIT (dBuV/m)	MARGIN (dB)	ANTENNA FACTOR (dB /m)	CABLE LOSS (dB)	PREAMP FACTOR (dB)	ANTENNA HEIGHT (cm)	TABLE ANGLE (Degree)	REMARK
5795	105.62	106.41			37.58	7.8	46.17	100	308	Peak
5795	95.07	95.86			37.58	7.8	46.17	100	308	Average

ANTENNA POLARITY & TEST DISTANCE: VERTICAL AT 3 M										
FREQ. (MHz)	EMISSION LEVEL (dBuV/m)	READ LEVEL (dBuV)	LIMIT (dBuV/m)	MARGIN (dB)	ANTENNA FACTOR (dB /m)	CABLE LOSS (dB)	PREAMP FACTOR (dB)	ANTENNA HEIGHT (cm)	TABLE ANGLE (Degree)	REMARK
5795	105.45	106.24			37.58	7.8	46.17	175	321	Peak
5795	94.86	95.65			37.58	7.8	46.17	175	321	Average

REMARKS:

1. Emission Level = Read Level+ Antenna Factor + Cable Loss- Preamp Factor
Margin value = Emission level – Limit value.
2. 5795MHz: Fundamental frequency.



OUBE DATA

802.11n (40MHZ)

ANTENNA POLARITY & TEST DISTANCE: HORIZONTAL AT 3 M										
FREQ. (MHz)	EMISSION LEVEL (dBuV/m)	READ LEVEL (dBuV)	LIMIT (dBuV/m)	MARGIN (dB)	ANTENNA FACTOR (dB /m)	CABLE LOSS (dB)	PREAMP FACTOR (dB)	ANTENNA HEIGHT (cm)	TABLE ANGLE (Degree)	REMARK
5589.43	57.01	58.19	68.3	-11.29	37.45	7.59	46.22	100	360	Peak
5974.18	58.21	58.67	68.3	-10.09	37.68	7.98	46.12	100	360	Peak
ANTENNA POLARITY & TEST DISTANCE: VERTICAL AT 3 M										
FREQ. (MHz)	EMISSION LEVEL (dBuV/m)	READ LEVEL (dBuV)	LIMIT (dBuV/m)	MARGIN (dB)	ANTENNA FACTOR (dB /m)	CABLE LOSS (dB)	PREAMP FACTOR (dB)	ANTENNA HEIGHT (cm)	TABLE ANGLE (Degree)	REMARK
5580.4	56.26	58.36	68.3	-12.04	36.55	7.58	46.23	100	0	Peak
5972.75	57.13	58.49	68.3	-11.17	36.78	7.98	46.12	100	0	Peak

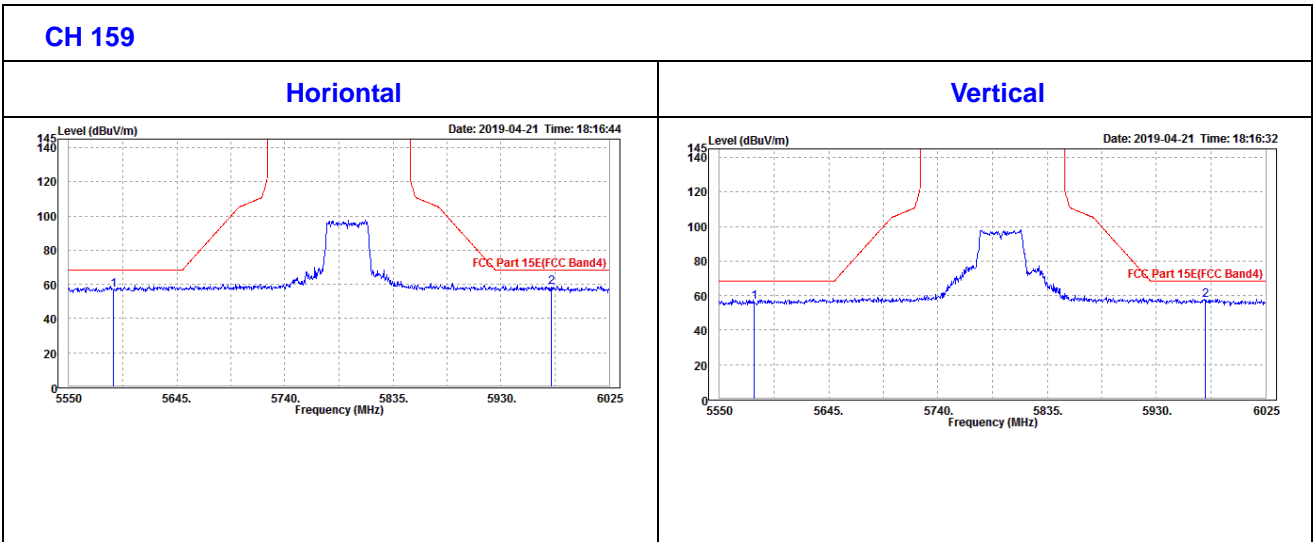



802.11ac (80MHz)

CHANNEL	TX Channel 155	DETECTOR FUNCTION	Peak (PK)
FREQUENCY RANGE	1GHz ~ 40GHz		Average (AV)

ANTENNA POLARITY & TEST DISTANCE: HORIZONTAL AT 3 M										
FREQ. (MHz)	EMISSION LEVEL (dBuV/m)	READ LEVEL (dBuV)	LIMIT (dBuV/m)	MARGIN (dB)	ANTENNA FACTOR (dB /m)	CABLE LOSS (dB)	PREAMP FACTOR (dB)	ANTENNA HEIGHT (cm)	TABLE ANGLE (Degree)	REMARK
5775	104.63	105.45			37.57	7.78	46.17	100	308	Peak
5775	94.45	95.27			37.57	7.78	46.17	100	308	Average
ANTENNA POLARITY & TEST DISTANCE: VERTICAL AT 3 M										
FREQ. (MHz)	EMISSION LEVEL (dBuV/m)	READ LEVEL (dBuV)	LIMIT (dBuV/m)	MARGIN (dB)	ANTENNA FACTOR (dB /m)	CABLE LOSS (dB)	PREAMP FACTOR (dB)	ANTENNA HEIGHT (cm)	TABLE ANGLE (Degree)	REMARK
5775	103.74	105.46			36.67	7.78	46.17	162	323	Peak
5775	93.48	95.2			36.67	7.78	46.17	162	323	Average

REMARKS:

1. Emission Level = Read Level+ Antenna Factor + Cable Loss- Preamp Factor
Margin value = Emission level – Limit value.
2. 5775MHz: Fundamental frequency.



OOBE DATA

802.11ac (80MHZ)

ANTENNA POLARITY & TEST DISTANCE: HORIZONTAL AT 3 M											
FREQ. (MHz)	EMISSION LEVEL (dBuV/m)	READ LEVEL (dBuV)	LIMIT (dBuV/m)	MARGIN (dB)	ANTENNA FACTOR (dB /m)	CABLE LOSS (dB)	PREAMP FACTOR (dB)	ANTENNA HEIGHT (cm)	TABLE ANGLE (Degree)	REMARK	
5584.68	55.98	57.17	68.3	-12.32	37.45	7.59	46.23	100	0	Peak	
5965.63	56.77	57.24	68.3	-11.53	37.68	7.97	46.12	100	0	Peak	
ANTENNA POLARITY & TEST DISTANCE: VERTICAL AT 3 M											
FREQ. (MHz)	EMISSION LEVEL (dBuV/m)	READ LEVEL (dBuV)	LIMIT (dBuV/m)	MARGIN (dB)	ANTENNA FACTOR (dB /m)	CABLE LOSS (dB)	PREAMP FACTOR (dB)	ANTENNA HEIGHT (cm)	TABLE ANGLE (Degree)	REMARK	
5578.5	56.99	58.19	68.3	-11.31	37.45	7.58	46.23	100	360	Peak	
5982.25	57.01	57.44	68.3	-11.29	37.69	7.99	46.11	100	360	Peak	

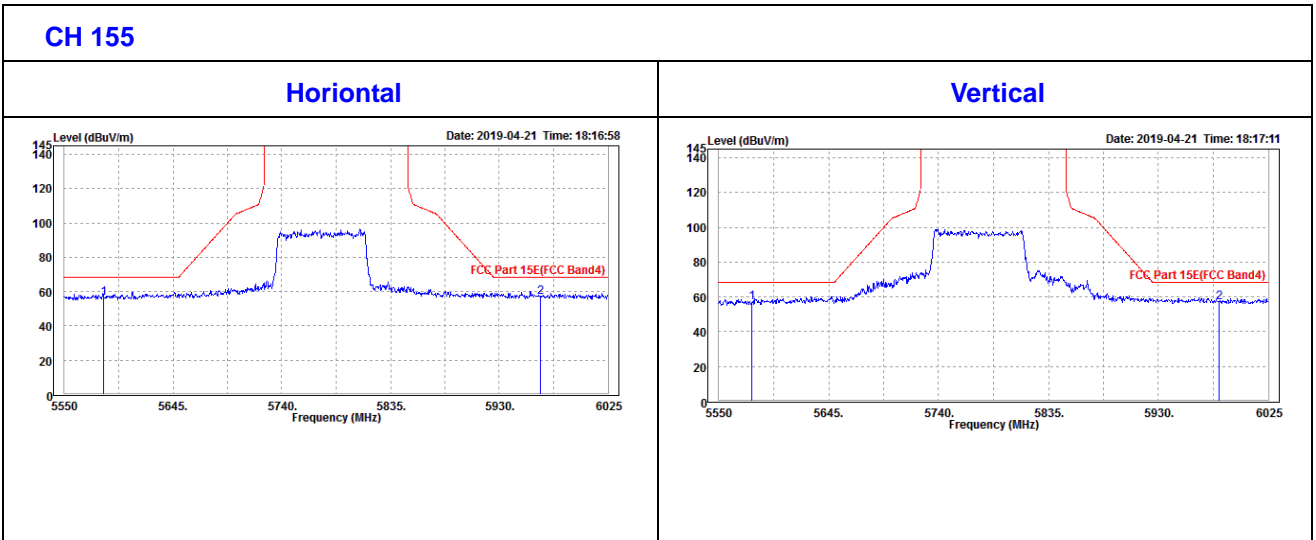



3.2 CONDUCTED EMISSION MEASUREMENT

3.2.1 LIMITS OF CONDUCTED EMISSION MEASUREMENT

FREQUENCY OF EMISSION (MHz)	CONDUCTED LIMIT (dBµV)	
	Quasi-peak	Average
0.15 ~ 0.5	66 to 56	56 to 46
0.5 ~ 5	56	46
5 ~ 30	60	50

- NOTE:**
1. The lower limit shall apply at the transition frequencies.
 2. The limit decreases in line with the logarithm of the frequency in the range of 0.15 to 0.50MHz.
 3. All emanations from a class A/B digital device or system, including any network of conductors and apparatus connected thereto, shall not exceed the level of field strengths specified above.

3.2.2 TEST INSTRUMENTS

Equipment	Manufacturer	Model No.	Serial No.	Last Cal.	Next Cal.
EMI Test Receiver	Rohde&Schwarz	ESR3	101900	Feb. 26,19	Feb. 25,20
EMC32 test software	Rohde&Schwarz	EMC32	NA	NA	NA
LISN network	Rohde&Schwarz	ENV216	101922	Feb. 26,19	Feb. 25,20

- NOTE:**
1. The test was performed in CE shielded room.
 2. The calibration interval of the above test instruments is 12 months. And the calibrations are traceable to CEPREI/CHINA, GRGT/CHINA and NIM/CHINA.

3.2.3 TEST PROCEDURES

- a. The EUT was placed 0.4 meters from the conducting wall of the shielded room with EUT being connected to the power mains through a line impedance stabilization network (LISN). Other support units were connected to the power mains through another LISN. The two LISNs provide 50 ohm/ 50uH of coupling impedance for the measuring instrument.
- b. Both lines of the power mains connected to the EUT were checked for maximum conducted interference.
- c. The frequency range from 150kHz to 30MHz was searched. Emission levels under (Limit - 20dB) was not recorded.

NOTE: All modes of operation were investigated and the worst-case emissions are reported.



3.2.4 DEVIATION FROM TEST STANDARD

No deviation.

3.2.5 TEST SETUP

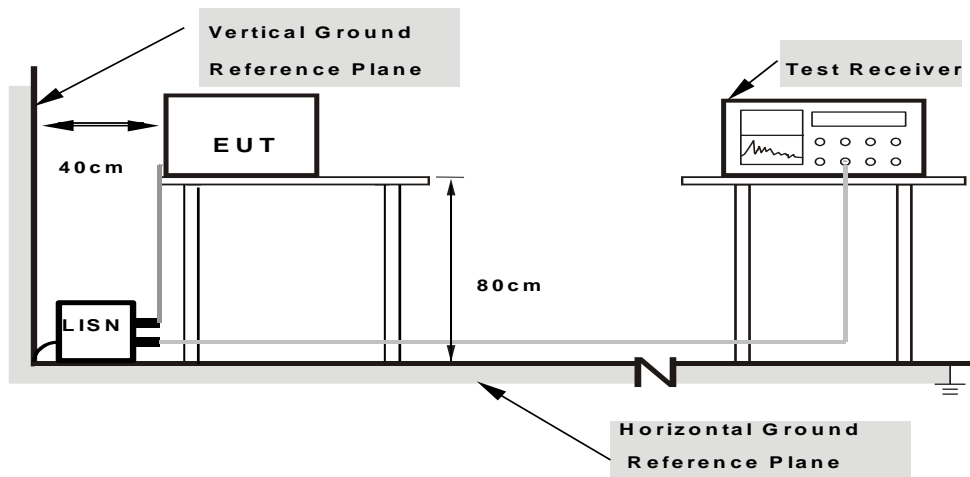

Note: 1.Support units were connected to second LISN.

2.Both of LISNs (AMN) are 80 cm from EUT and at least 80 cm from other units and other metal planes

For the actual test configuration, please refer to the attached file (Test Setup Photo).

3.2.6 EUT OPERATING CONDITIONS

Same as 3.1.6.



3.2.7 TEST RESULTS

CONDUCTED WORST-CASE DATA :

Frequency Range	150KHz ~ 30MHz	Detector Function & Resolution Bandwidth	Quasi-Peak (QP) / Average (AV), 9 kHz
Input Power	120Vac, 60Hz	Environmental Conditions	25deg. C, 52RH
Tested By	John Wen	TEST DATE	2019/04/08
Test Voltage	DC 24V From Adapter		

Frequency (MHz)	QuasiPeak (dBuV)	CAverage (dBuV)	Limit (dBuV)	Margin (dB)	Line	Filter	Corr. (dB)
0.150000	---	25.95	56.00	-30.05	L	ON	9.9
0.150000	42.34	---	66.00	-23.66	L	ON	9.9
0.216000	---	21.05	52.97	-31.92	L	ON	9.9
0.216000	35.67	---	62.97	-27.30	L	ON	9.9
0.568000	---	32.26	46.00	-13.74	L	ON	10.0
0.568000	39.66	---	56.00	-16.34	L	ON	10.0
0.944000	---	18.95	46.00	-27.05	L	ON	10.1
0.944000	27.45	---	56.00	-28.55	L	ON	10.1
1.966000	---	26.72	46.00	-19.28	L	ON	10.1
1.966000	32.61	---	56.00	-23.39	L	ON	10.1
2.220000	---	24.50	46.00	-21.50	L	ON	10.1
2.220000	30.49	---	56.00	-25.51	L	ON	10.1

- REMARKS:**
1. Q.P. and AV. are abbreviations of quasi-peak and average individually.
 2. "-": The Quasi-peak reading value also meets average limit and measurement with the average detector is unnecessary.
 3. The emission levels of other frequencies were very low against the limit.
 4. Margin value = Emission level - Limit value
 5. Correction factor = Insertion loss + Cable loss
 6. Emission Level = Correction Factor + Reading Value.

Full Spectrum

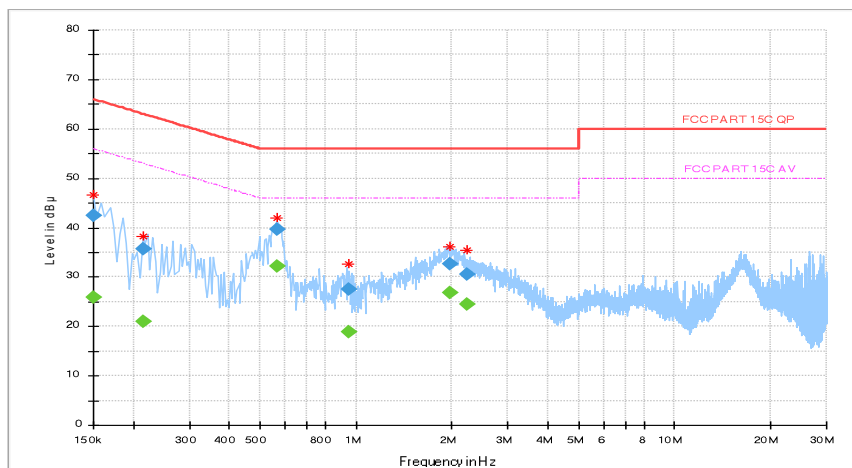



Frequency Range	150KHz ~ 30MHz	Detector Function & Resolution Bandwidth	Quasi-Peak (QP) / Average (AV), 9 kHz
Input Power	120Vac, 60Hz	Environmental Conditions	25deg. C, 52RH
Tested By	John Wen	TEST DATE	2019/04/08
Test Voltage	DC 24V From Adapter		

Frequency (MHz)	QuasiPeak (dBuV)	CAverage (dBuV)	Limit (dBuV)	Margin (dB)	Line	Filter	Corr. (dB)
0.150000	---	28.14	56.00	-27.86	N	ON	9.9
0.150000	42.47	---	66.00	-23.53	N	ON	9.9
0.424000	---	24.20	47.37	-23.17	N	ON	9.9
0.424000	33.61	---	57.37	-23.76	N	ON	9.9
0.560000	---	33.67	46.00	-12.33	N	ON	9.9
0.560000	41.97	---	56.00	-14.03	N	ON	9.9
0.876000	---	22.67	46.00	-23.33	N	ON	10.0
0.876000	31.29	---	56.00	-24.71	N	ON	10.0
1.552000	---	25.26	46.00	-20.74	N	ON	10.0
1.552000	32.34	---	56.00	-23.66	N	ON	10.0
3.920000	---	21.88	46.00	-24.12	N	ON	10.1
3.920000	27.43	---	56.00	-28.57	N	ON	10.1

- REMARKS:**
1. Q.P. and AV. are abbreviations of quasi-peak and average individually.
 2. "-": The Quasi-peak reading value also meets average limit and measurement with the average detector is unnecessary.
 3. The emission levels of other frequencies were very low against the limit.
 4. Margin value = Emission level - Limit value
 5. Correction factor = Insertion loss + Cable loss
 6. Emission Level = Correction Factor + Reading Value.

Full Spectrum

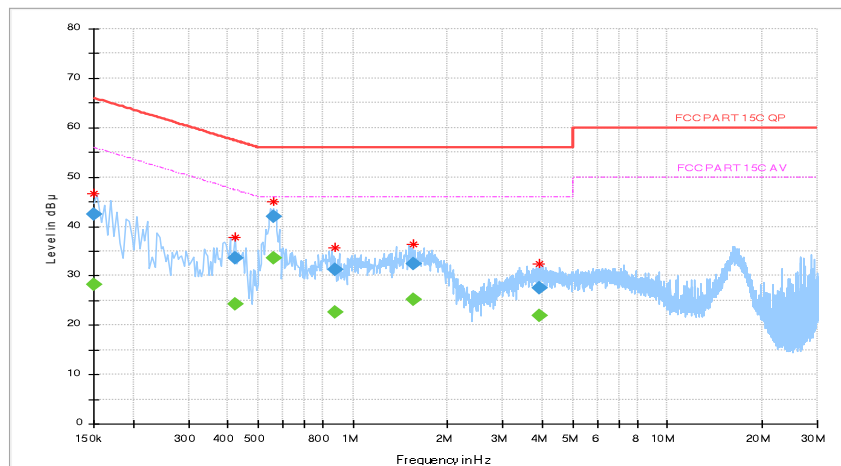



3.3 MAXIMUM CONDUCTED OUTPUT POWER MEASUREMENT

3.3.1 LIMITS OF MAXIMUM CONDUCTED OUTPUT POWER MEASUREMENT

Operation Band	EUT Category		LIMIT
U-NII-1		Outdoor Access Point	1 Watt (30 dBm) (Max. e.i.r.p ≤ 125mW(21 dBm) at any elevation angle above 30 degrees as measured from the horizon)
		Fixed point-to-point Access Point	1 Watt (30 dBm)
		Indoor Access Point	1 Watt (30 dBm)
	√	Client devices	250mW (24 dBm)
U-NII-2A	√		250mW (24 dBm) or 11 dBm+10 log B*
U-NII-2C	√		250mW (24 dBm) or 11 dBm+10 log B*
U-NII-3	√		1 Watt (30 dBm)

NOTE: Where B is the 26dB emission bandwidth in MHz.



3.3.2 TEST SETUP

FOR POWER OUTPUT MEASUREMENT

802.11a, 802.11n (20MHz), 802.11n (40MHz) TEST CONFIGURATION

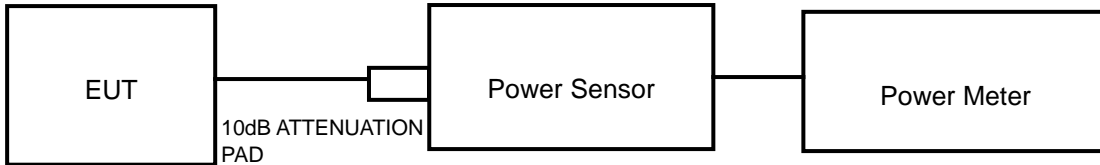

11ac TEST CONFIGURATION

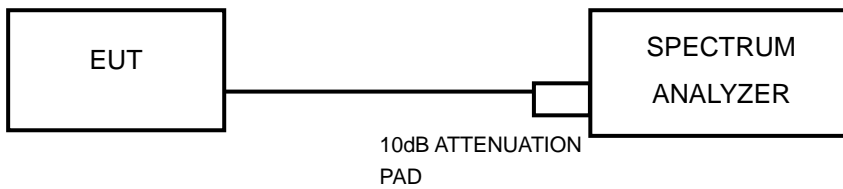

FOR 26dB BANDWIDTH

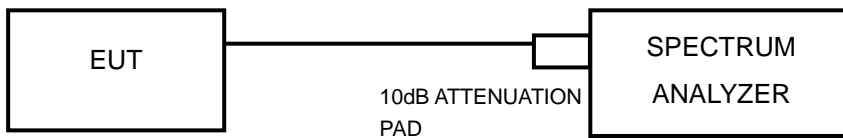

3.3.3 TEST INSTRUMENTS

Equipment	Manufacturer	Model No.	Serial No.	Last Cal.	Next Cal.
Power Meter	ANRITSU	ML2495A	1506002	Feb. 26,19	Feb. 25,20
EXA Signal Analyzer	KEYSIGHT	N9010A-526	MY54510322	Feb. 26,19	Feb. 25,20
EXA Signal Analyzer	KEYSIGHT	N9010A-544	MY54510355	Feb. 26,19	Feb. 25,20
Power Sensor	ANRITSU	MA2411B	1339352	Feb. 26,19	Feb. 25,20

NOTE:

1. The calibration interval of the above test instruments is 12 months and the calibrations are traceable to CEPREI/CHINA, GRGT/CHINA and NIM/CHINA.
2. The test was performed in RF Oven room.



3.3.4 TEST PROCEDURE

FOR POWER MEASUREMENT

For 802.11a, 802.11n (20MHz), 802.11n (40MHz)

Method PM is used to perform output power measurement, trigger and gating function of wide band power meter is enabled to measure max output power of TX on burst. Duty factor is not added to measured value.

For 802.11ac (80MHz)

1. Measure the duty cycle, x , of the transmitter output signal as described in II.B.
2. Set span to encompass the EBW (or, alternatively, the entire 99% occupied bandwidth) of the signal.
3. Set RBW = 1 MHz.
4. Set VBW \geq 3 MHz.
5. Number of points in sweep $\geq 2 \times \text{span} / \text{RBW}$. (This ensures that bin-to-bin spacing is $\leq \text{RBW}/2$, so that narrowband signals are not lost between frequency bins.)
6. Sweep time = auto.
7. Detector = power averaging (rms), if available. Otherwise, use sample detector mode.
8. Do not use sweep triggering. Allow the sweep to “free run.”
9. Trace average at least 100 traces in power averaging (rms) mode; however, the number of traces to be averaged shall be increased above 100 as needed to ensure that the average accurately represents the true average over the on and off periods of the transmitter.
10. Add $10 \log (1/x)$, where x is the duty cycle, to the measured power to compute the average power during the actual transmission times (because the measurement represents an average over both the on and off times of the transmission). For example, add $10 \log (1/0.25) = 6 \text{ dB}$ if the duty cycle is 25%.



FOR 99 PERCENT OCCUPIED BANDWIDTH

The following procedure shall be used for measuring (99 %) power bandwidth:

1. Set center frequency to the nominal EUT channel center frequency.
2. Set span = 1.5 times to 5.0 times the OBW.
3. Set RBW = 1 % to 5 % of the OBW
4. Set VBW $\geq 3 \cdot$ RBW
5. Video averaging is not permitted. Where practical, a sample detection and single sweep mode shall be used. Otherwise, peak detection and max hold mode (until the trace stabilizes) shall be used.
6. Use the 99 % power bandwidth function of the instrument (if available).
7. If the instrument does not have a 99 % power bandwidth function, the trace data points are recovered and directly summed in power units. The recovered amplitude data points, beginning at the lowest frequency, are placed in a running sum until 0.5 % of the total is reached; that frequency is recorded as the lower frequency. The process is repeated until 99.5 % of the total is reached; that frequency is recorded as the upper frequency. The 99% occupied bandwidth is the difference between these two frequencies.

FOR 26dB BANDWIDTH

- 1) Set RBW = approximately 1% of the emission bandwidth.
- 2) Set the VBW > RBW.
- 3) Detector = Peak.
- 4) Trace mode = max hold.
- 5) Measure the maximum width of the emission that is 26 dB down from the peak of the emission. Compare this with the RBW setting of the analyzer. Readjust RBW and repeat measurement as needed until the RBW/EBW ratio is approximately 1%.

FOR 6dB BANDWIDTH

1. Set RBW = 100 kHz.
2. Set the video bandwidth (VBW) ≥ 3 RBW.
3. Detector = Peak.
4. Trace mode = max hold.
5. Sweep = auto couple.
6. Allow the trace to stabilize.
7. Measure the maximum width of the emission that is constrained by the frequencies associated with the two outermost amplitude points (upper and lower frequencies) that are attenuated by 6 dB relative to the maximum level measured in the fundamental emission.



3.3.5 DEVIATION FROM TEST STANDARD

No deviation.

3.3.6 EUT OPERATING CONDITIONS

The software provided by client to enable the EUT under transmission condition continuously at specific channel frequencies individually.



3.3.7 TEST RESULTS

OUTPUT POWER:

802.11a

CHANNEL	CHANNEL FREQUENCY (MHz)	AVERAGE POWER (dBm)	AVERAGE POWER (mW)	POWER LIMIT (dBm)	PASS/FAIL
36	5180	14.25	26.607	24	PASS
40	5200	14.13	25.882	24	PASS
48	5240	14.28	26.792	24	PASS
52	5260	14.32	27.040	24	PASS
60	5300	14.46	27.925	24	PASS
64	5320	14.54	28.445	24	PASS
100	5500	14.33	27.102	24	PASS
116	5580	14.43	27.733	24	PASS
140	5700	14.32	27.040	24	PASS
149	5745	12.40	17.378	30	PASS
157	5785	12.10	16.218	30	PASS
165	5825	12.38	17.298	30	PASS

802.11n (20MHz)

CHANNEL	CHANNEL FREQUENCY (MHz)	AVERAGE POWER (dBm)	AVERAGE POWER (mW)	POWER LIMIT (dBm)	PASS/FAIL
36	5180	11.29	13.459	24	PASS
40	5200	11.87	15.382	24	PASS
48	5240	12.10	16.218	24	PASS
52	5260	12.23	16.711	24	PASS
60	5300	12.50	17.783	24	PASS
64	5320	12.44	17.539	24	PASS
100	5500	12.43	17.498	24	PASS
116	5580	12.18	16.520	24	PASS
140	5700	11.82	15.205	24	PASS
149	5745	11.58	14.388	30	PASS
157	5785	11.99	15.812	30	PASS
165	5825	11.81	15.171	30	PASS



802.11n (40MHz)

CHANNEL	CHANNEL FREQUENCY (MHz)	AVERAGE POWER (dBm)	AVERAGE POWER (mW)	POWER LIMIT (dBm)	PASS/FAIL
38	5190	9.66	9.247	24	PASS
46	5230	11.66	14.655	24	PASS
54	5270	12.23	16.711	24	PASS
62	5310	12.60	18.197	24	PASS
102	5510	12.12	16.293	24	PASS
110	5550	12.13	16.331	24	PASS
134	5670	11.56	14.322	24	PASS
151	5755	11.67	14.689	30	PASS
159	5798	12.02	15.922	30	PASS

802.11ac (80MHz)

CHANNEL	CHANNEL FREQUENCY (MHz)	AVERAGE POWER (dBm)	AVERAGE POWER (mW)	POWER LIMIT (dBm)	PASS/FAIL
42	5210	10.39	10.940	24	PASS
58	5290	10.36	10.864	24	PASS
106	5530	10.32	10.765	24	PASS
155	5775	10.34	10.814	30	PASS



99% OCCUPIED BANDWIDTH & 26dB BANDWIDTH/6dB BANDWIDTH:

802.11a

CHANNEL	CHANNEL FREQUENCY (MHz)	99% OCCUPIED BANDWIDTH	26dB BANDWIDTH (MHz)	PASS/FAIL
36	5180	17.10	21.70	PASS
40	5200	17.16	21.63	PASS
48	5240	17.04	21.39	PASS
52	5260	17.04	21.44	PASS
60	5300	17.10	21.58	PASS
64	5320	17.10	21.69	PASS
100	5500	16.98	21.40	PASS
116	5580	17.04	21.43	PASS
140	5700	16.86	21.64	PASS
CHANNEL	CHANNEL FREQUENCY (MHz)	99% OCCUPIED BANDWIDTH	6dB BANDWIDTH (MHz)	PASS/FAIL
149	5745	16.56	16.35	PASS
157	5785	16.62	16.36	PASS
165	5825	16.56	16.36	PASS



802.11n (20MHz)

CHANNEL	CHANNEL FREQUENCY (MHz)	99% OCCUPIED BANDWIDTH	26dB BANDWIDTH (MHz)	PASS/FAIL
36	5180	17.88	21.58	PASS
40	5200	17.82	21.41	PASS
48	5240	17.88	21.22	PASS
52	5260	17.88	21.24	PASS
60	5300	17.82	21.40	PASS
64	5320	17.94	21.24	PASS
100	5500	17.82	21.41	PASS
116	5580	17.88	21.36	PASS
140	5700	17.94	21.32	PASS
CHANNEL	CHANNEL FREQUENCY (MHz)	99% OCCUPIED BANDWIDTH	6dB BANDWIDTH (MHz)	PASS/FAIL
149	5745	17.88	17.70	PASS
157	5785	17.82	17.68	PASS
165	5825	17.88	17.65	PASS



802.11n (40MHz)

CHANNEL	CHANNEL FREQUENCY (MHz)	99% OCCUPIED BANDWIDTH	26dB BANDWIDTH (MHz)	PASS/FAIL
38	5190	36.54	40.57	PASS
46	5230	36.54	40.43	PASS
54	5270	36.54	48.46	PASS
62	5310	36.48	44.03	PASS
102	5510	36.54	40.32	PASS
110	5550	36.48	40.49	PASS
134	5670	36.48	40.37	PASS
CHANNEL	CHANNEL FREQUENCY (MHz)	99% OCCUPIED BANDWIDTH	6dB BANDWIDTH (MHz)	PASS/FAIL
151	5755	36.54	36.38	PASS
159	5795	36.54	36.41	PASS

802.11ac (80MHz)

CHANNEL	CHANNEL FREQUENCY (MHz)	99% OCCUPIED BANDWIDTH	26dB BANDWIDTH (MHz)	PASS/FAIL
42	5210	75.72	80.64	PASS
58	5290	75.72	80.83	PASS
106	5530	75.60	81.32	PASS
CHANNEL	CHANNEL FREQUENCY (MHz)	99% OCCUPIED BANDWIDTH	6dB BANDWIDTH (MHz)	PASS/FAIL
155	5775	75.60	75.47	PASS



BUREAU VERITAS

Test Report No.: RF190326W003-3

For U-NII-1:

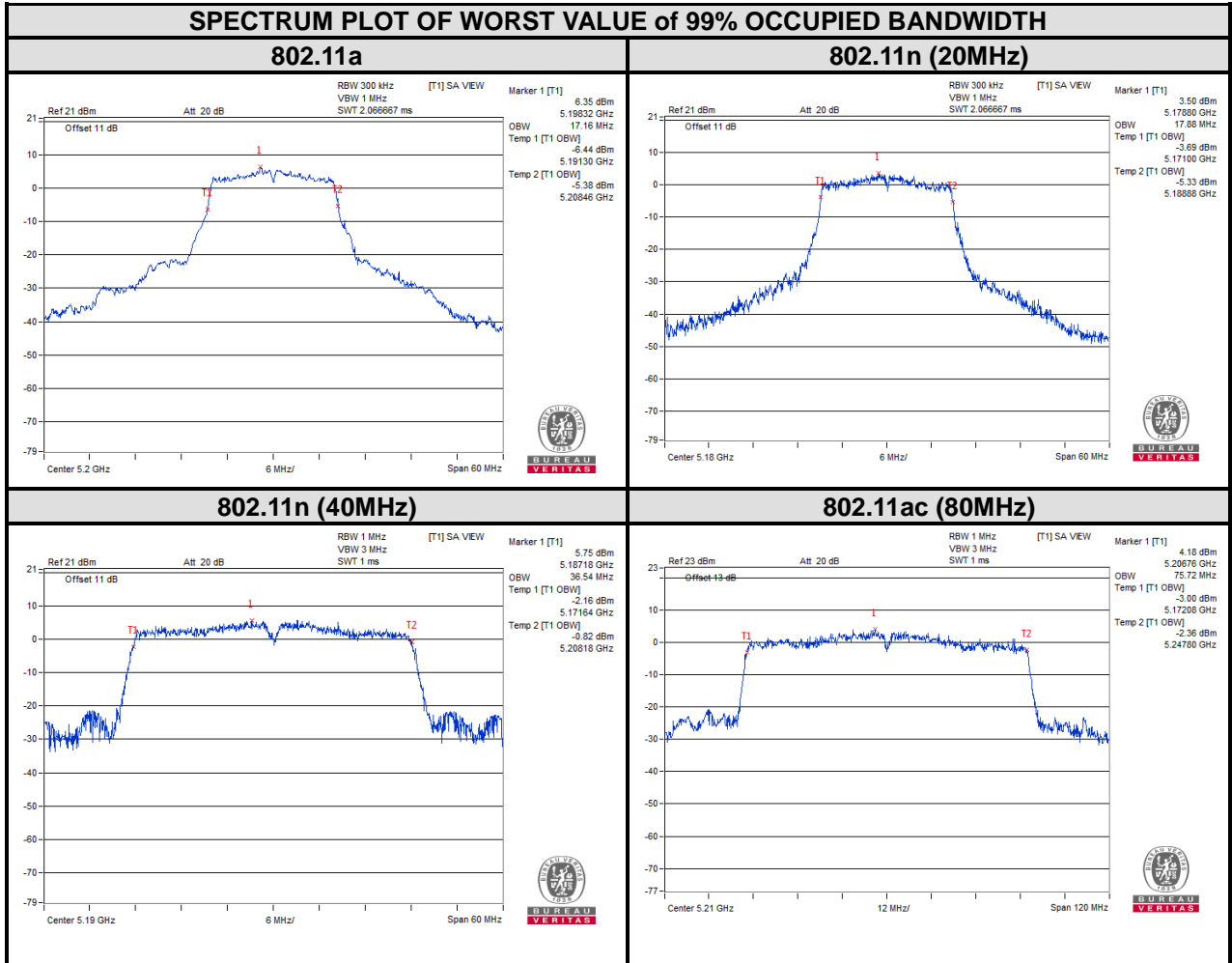

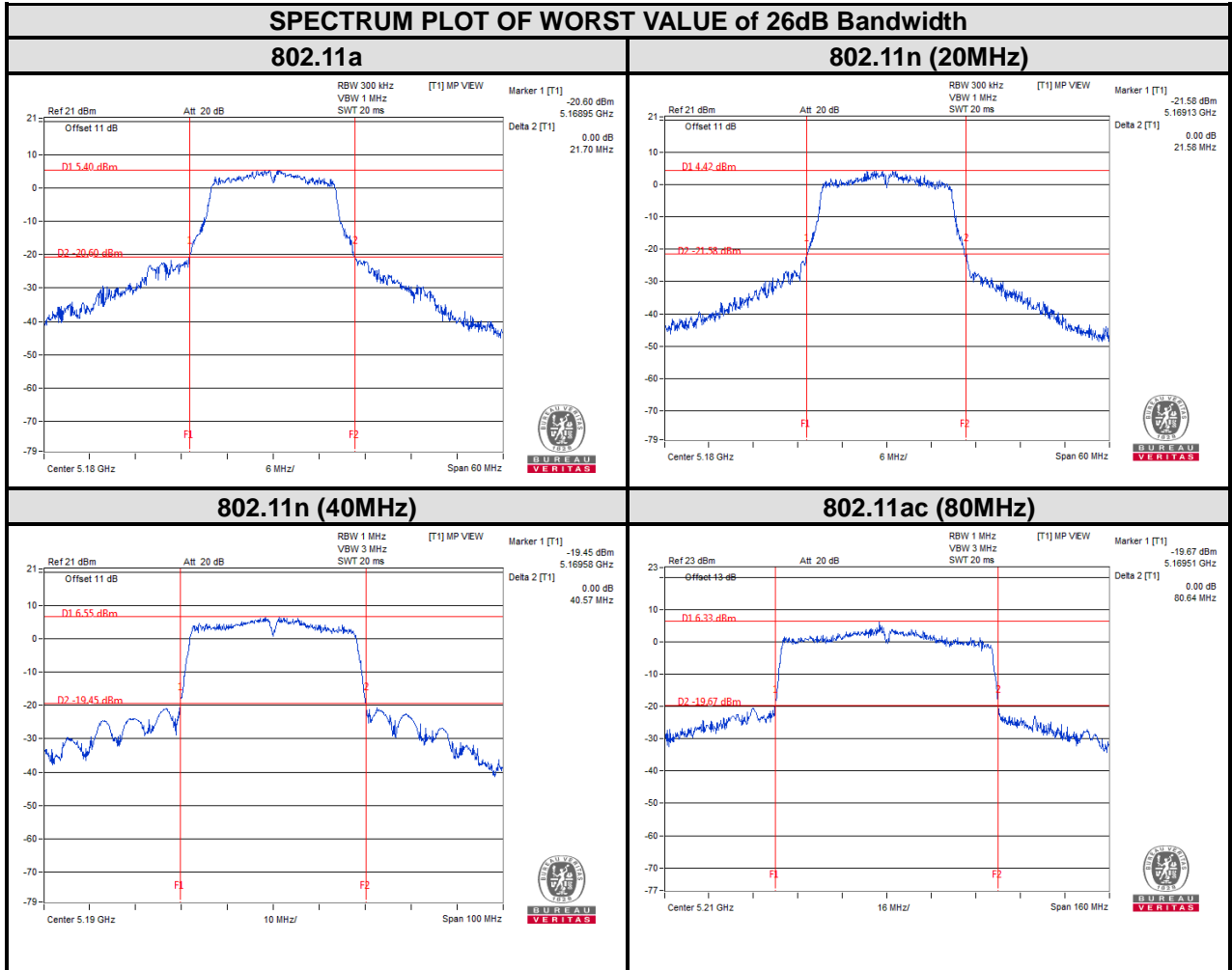



BUREAU VERITAS

Test Report No.: RF190326W003-3

For U-NII-2A:

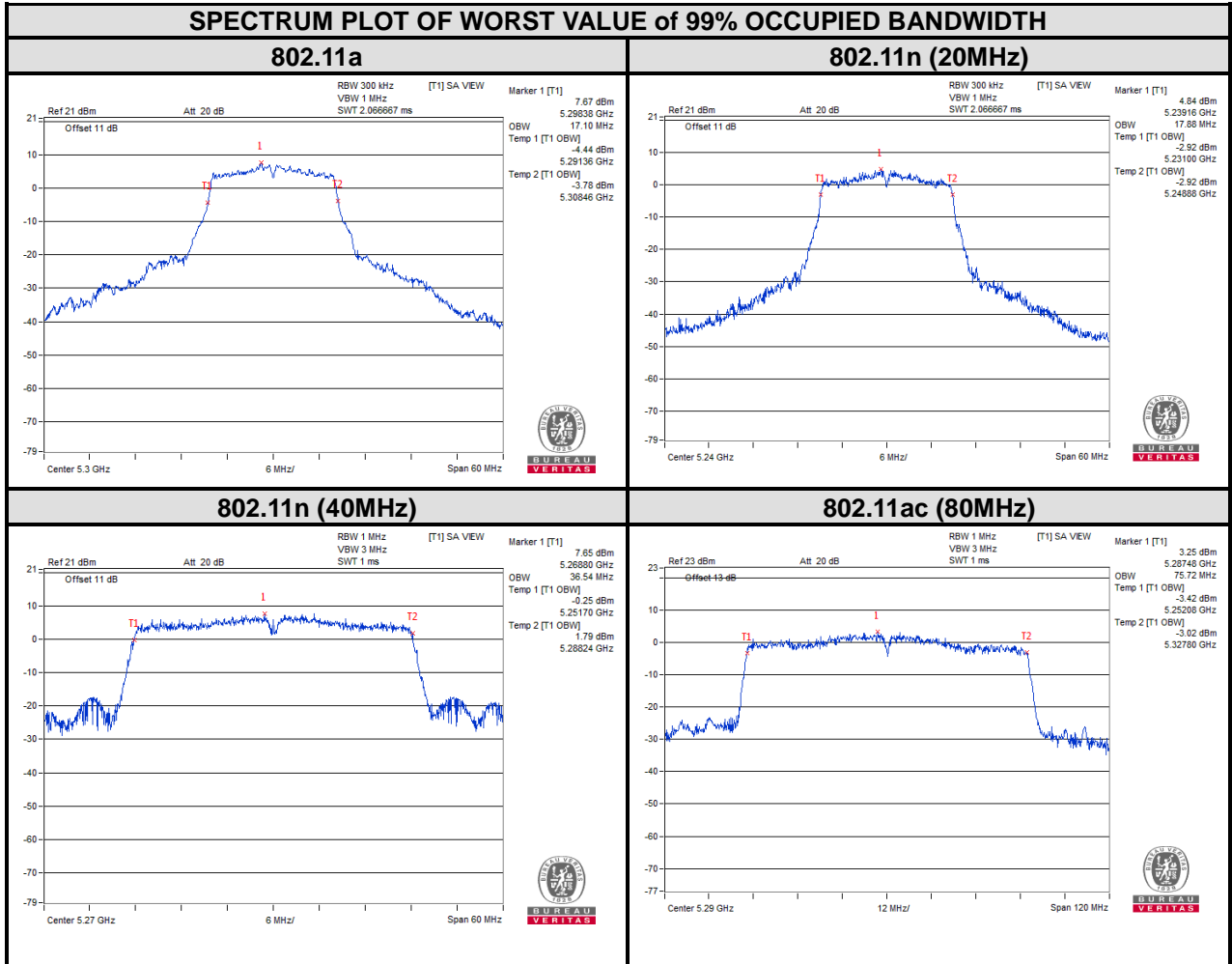

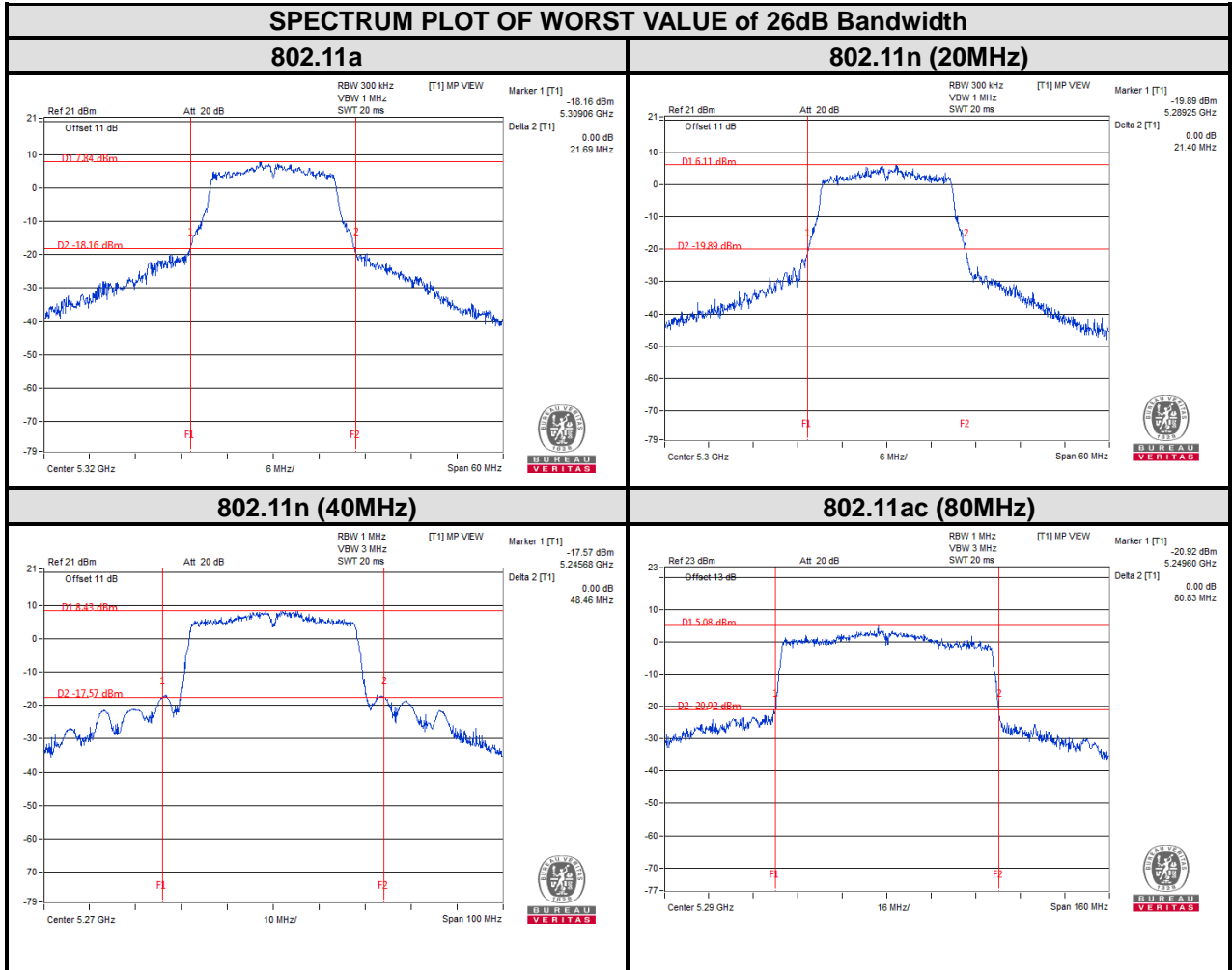



BUREAU VERITAS

Test Report No.: RF190326W003-3

For U-NII-2C:

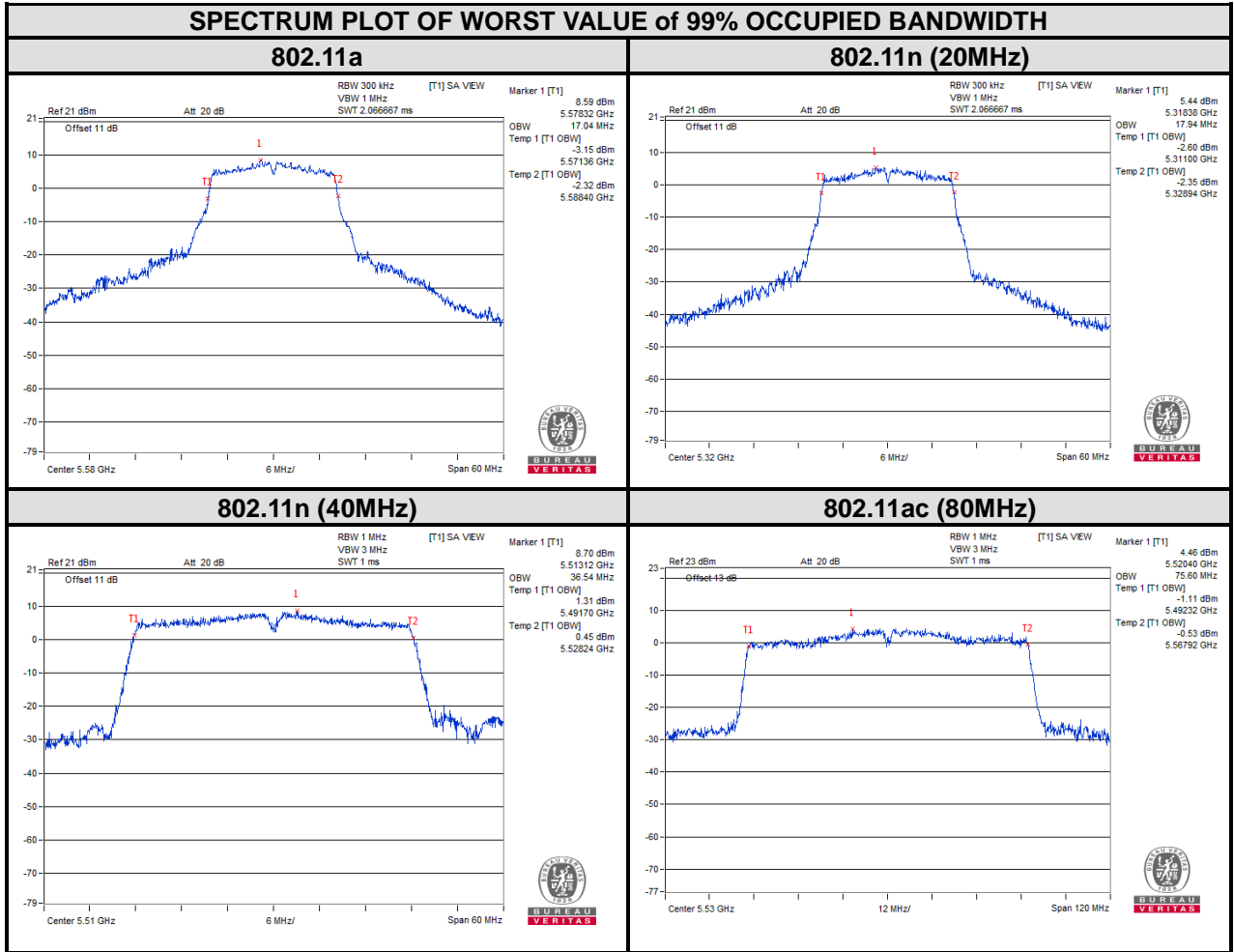

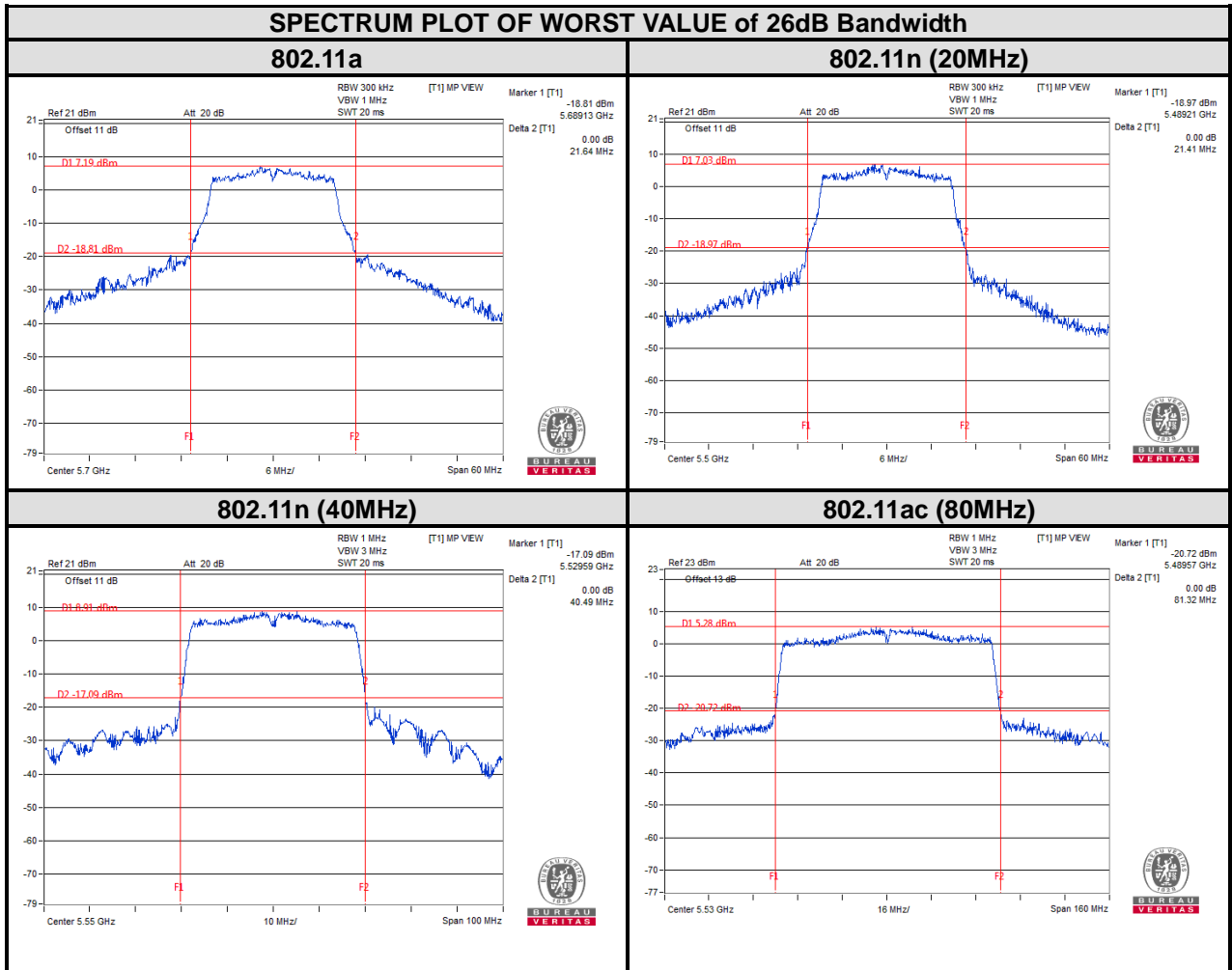



BUREAU VERITAS

Test Report No.: RF190326W003-3

For U-NII-3:

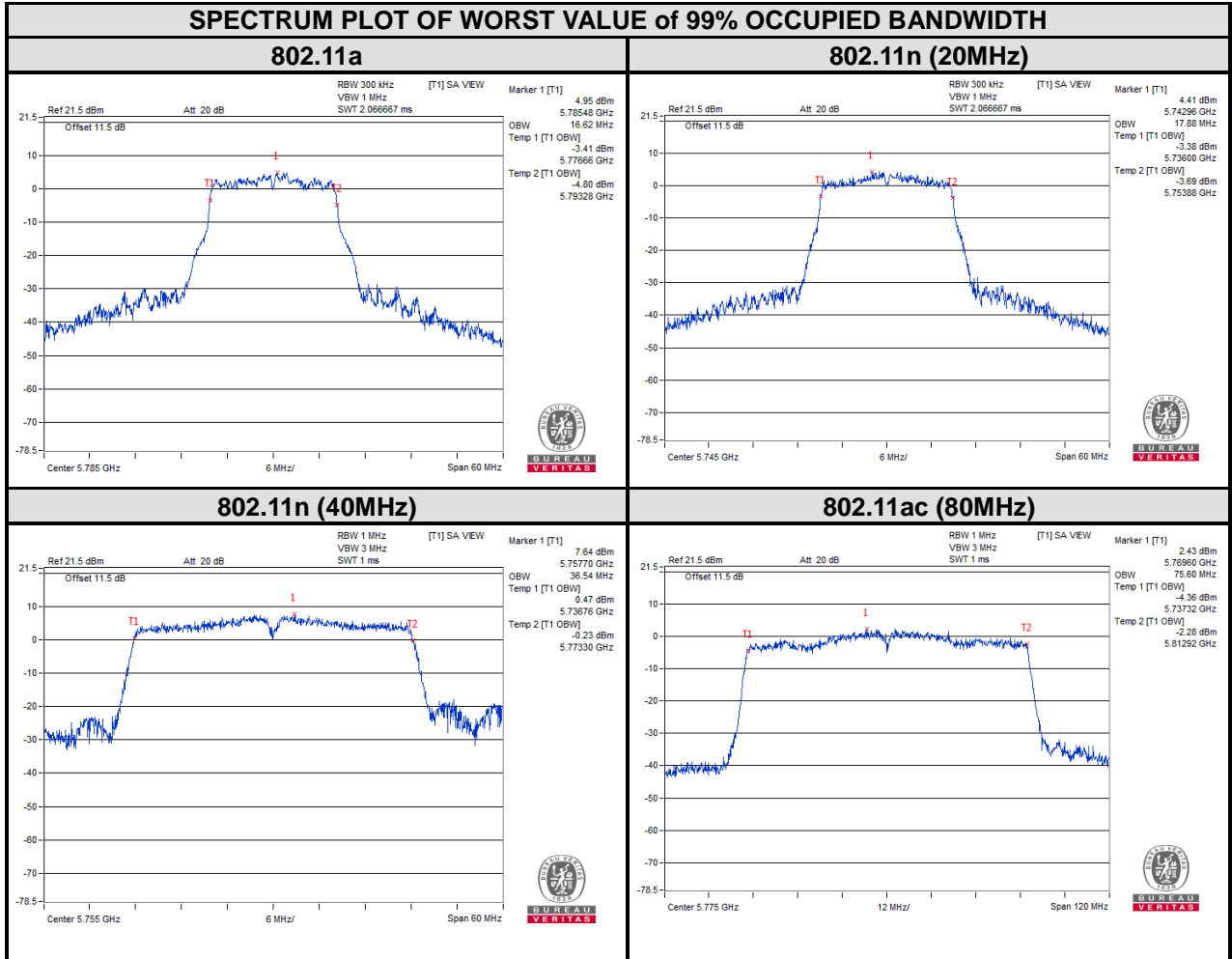

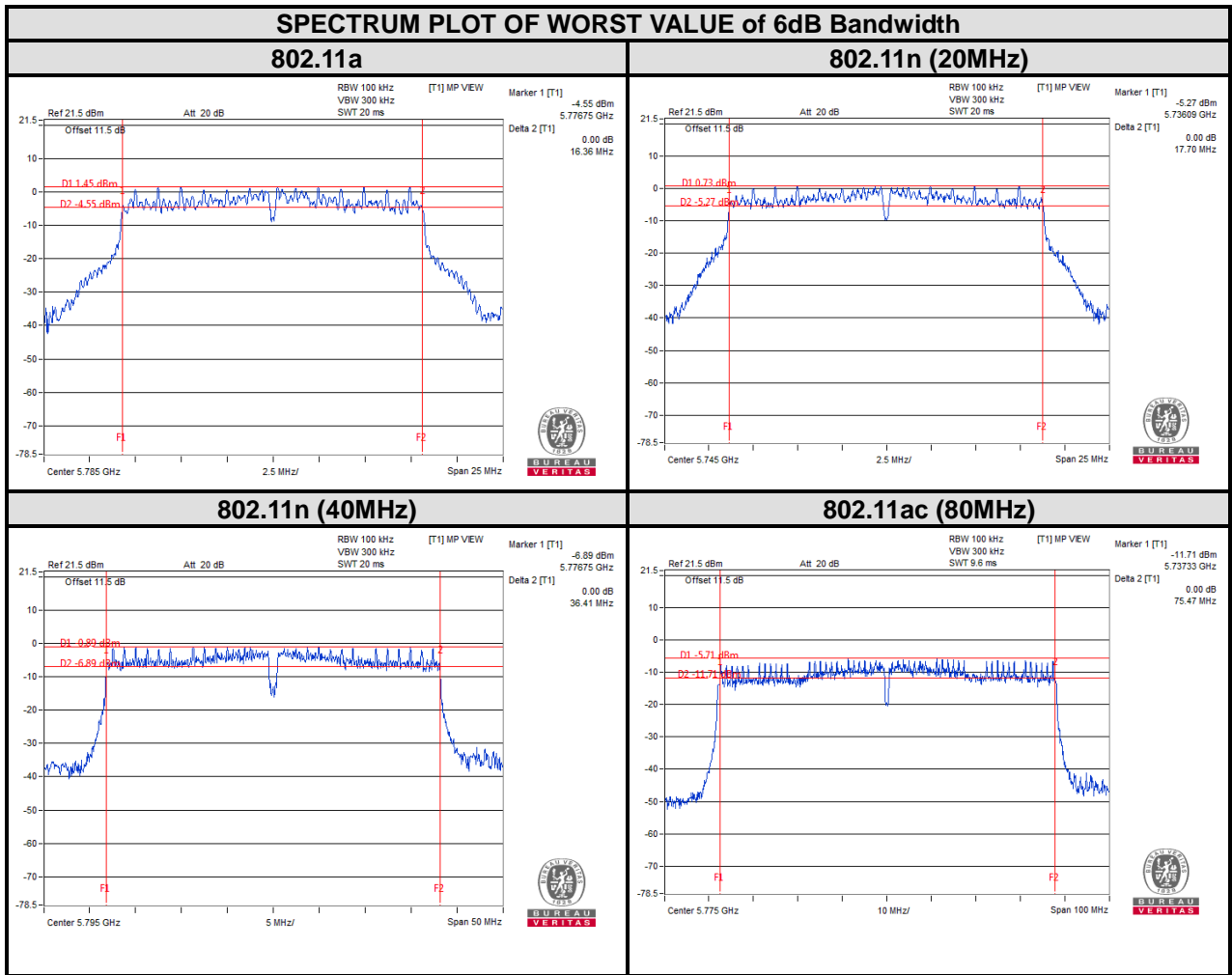



3.4 MAXIMUM POWER SPECTRAL DENSITY MEASUREMENT

3.4.1 LIMITS OF MAXIMUM POWER SPECTRAL DENSITY MEASUREMENT

Operation Band	EUT Category		LIMIT
U-NII-1		Outdoor Access Point	17dBm/ MHz
		Fixed point-to-point Access Point	
		Indoor Access Point	
	√	Client devices	11dBm/ MHz
U-NII-2A	√		11dBm/ MHz
U-NII-2C	√		11dBm/ MHz
U-NII-3	√		30dBm/ 500kHz

3.4.2 TEST SETUP

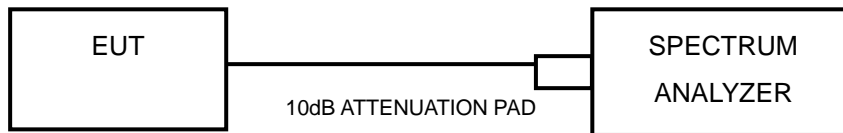

3.4.3 TEST INSTRUMENTS

Refer to section 3.3.3 to get information of above instrument.



3.4.4 TEST PROCEDURES

Using method SA-2

- 1) Set span to encompass the entire emission bandwidth (EBW) of the signal.
- 2) Set RBW = 1 MHz, Set VBW \geq 3 MHz, Detector = RMS
- 3) Set Channel power measure = 1MHz
- 4) Sweep time = auto, trigger set to "free run".
- 5) Trace average at least 100 traces in power averaging mode.
- 6) Add $10 \log(1/x)$, where x is the duty cycle, to the measured power in order to compute the average power during the actual transmission times (because the measurement represents an average over both the on and off times of the transmission).
- 7) Record the max value

3.4.5 DEVIATION FROM TEST STANDARD

No deviation.

3.4.6 EUT OPERATING CONDITIONS

Same as 3.1.6.



3.4.7 TEST RESULTS

For U-NII-1 & U-NII-2A & U-NII-2C:

802.11a

CHANNEL	FREQUENCY (MHz)	PSD w/o Duty Factor (dBm/MHz)	Duty Factor	PSD with Duty Factor (dBm/MHz)	MAXIMUM LIMIT (dBm/MHz)	PASS/FAIL
36	5180	8.21	1.24	9.45	11	PASS
40	5200	8.22	1.24	9.46	11	PASS
48	5240	8.74	1.24	9.98	11	PASS
52	5260	9.03	1.24	10.27	11	PASS
60	5300	9.67	1.24	10.91	11	PASS
64	5320	9.74	1.24	10.98	11	PASS
100	5500	9.12	1.24	10.36	11	PASS
116	5580	9.21	1.24	10.45	11	PASS
140	5700	9.40	1.24	10.64	11	PASS

802.11n (20MHz)

CHANNEL	FREQUENCY (MHz)	PSD w/o Duty Factor (dBm/MHz)	Duty Factor	PSD with Duty Factor (dBm/MHz)	MAXIMUM LIMIT (dBm/MHz)	PASS/FAIL
36	5180	6.08	1.15	7.23	11	PASS
40	5200	6.89	1.15	8.04	11	PASS
48	5240	7.44	1.15	8.59	11	PASS
52	5260	7.16	1.15	8.31	11	PASS
60	5300	7.59	1.15	8.74	11	PASS
64	5320	8.93	1.15	10.08	11	PASS
100	5500	9.1	1.15	10.25	11	PASS
116	5580	9.59	1.15	10.74	11	PASS
140	5700	8.11	1.15	9.26	11	PASS



802.11n (40MHz)

CHANNEL	FREQUENCY (MHz)	PSD w/o Duty Factor (dBm/MHz)	Duty Factor	PSD with Duty Factor (dBm/MHz)	MAXIMUM LIMIT (dBm/MHz)	PASS/FAIL
38	5190	3.38	1.89	5.27	11	PASS
46	5230	3.6	1.89	5.49	11	PASS
54	5270	5.04	1.89	6.93	11	PASS
62	5310	6.29	1.89	8.18	11	PASS
102	5510	6.44	1.89	8.33	11	PASS
110	5550	5.21	1.89	7.10	11	PASS
134	5670	5.11	1.89	7.00	11	PASS

802.11ac (80MHz)

CHANNEL	FREQUENCY (MHz)	PSD w/o Duty Factor (dBm/MHz)	Duty Factor	PSD with Duty Factor (dBm/MHz)	MAXIMUM LIMIT (dBm/MHz)	PASS/FAIL
42	5210	1.89	2.15	4.04	11	PASS
58	5290	1.64	2.15	3.79	11	PASS
106	5530	3.39	2.15	5.54	11	PASS



For U-NII-3:

802.11a

CHANNEL	FREQUENCY (MHz)	PSD w/o Duty Factor (dBm/MHz)	PSD w/o Duty Factor (dBm/500kHz)	Duty Factor	PSD with Duty Factor (dBm/500kHz)	LIMIT (dBm/500kHz)	PASS /FAIL
149	5745	1.90	-1.11	1.24	0.13	30	PASS
157	5785	1.61	-1.4	1.24	-0.16	30	PASS
165	5825	2.26	-0.75	1.24	0.49	30	PASS

802.11n (20MHz)

CHANNEL	FREQUENCY (MHz)	PSD w/o Duty Factor (dBm/MHz)	PSD w/o Duty Factor (dBm/500kHz)	Duty Factor	PSD with Duty Factor (dBm/500kHz)	LIMIT (dBm/500kHz)	PASS /FAIL
149	5745	0.26	-2.75	1.15	-1.6	30	PASS
157	5785	0.69	-2.32	1.15	-1.17	30	PASS
165	5825	0.62	-2.39	1.15	-1.24	30	PASS

802.11n (40MHz)

CHANNEL	FREQUENCY (MHz)	PSD w/o Duty Factor (dBm/MHz)	PSD w/o Duty Factor (dBm/500kHz)	Duty Factor	PSD with Duty Factor (dBm/500kHz)	LIMIT (dBm/500kHz)	PASS /FAIL
151	5755	-2.51	-5.52	1.89	-3.63	30	PASS
159	5795	-2.12	-5.13	1.89	-3.24	30	PASS

802.11ac (80MHz)

CHANNEL	FREQUENCY (MHz)	PSD w/o Duty Factor (dBm/MHz)	PSD w/o Duty Factor (dBm/500kHz)	Duty Factor	PSD with Duty Factor (dBm/500kHz)	LIMIT (dBm/500kHz)	PASS /FAIL
155	5775	-7.89	-10.9	2.15	-8.75	30	PASS



BUREAU VERITAS

Test Report No.: RF190326W003-3

For 5180~5240MHz

PSD w/o Duty Factor

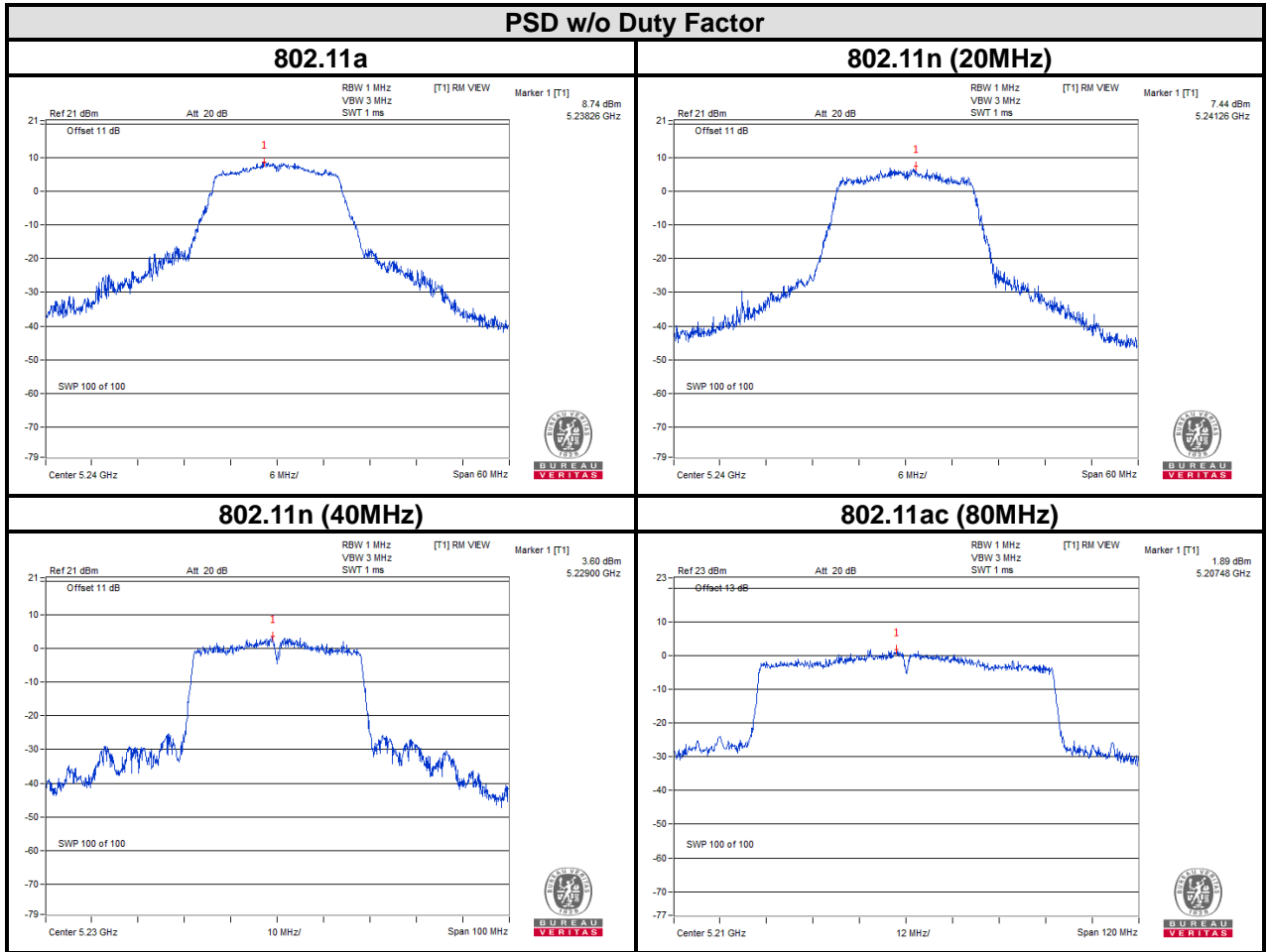



BUREAU VERITAS

Test Report No.: RF190326W003-3

For 5260~5320MHz

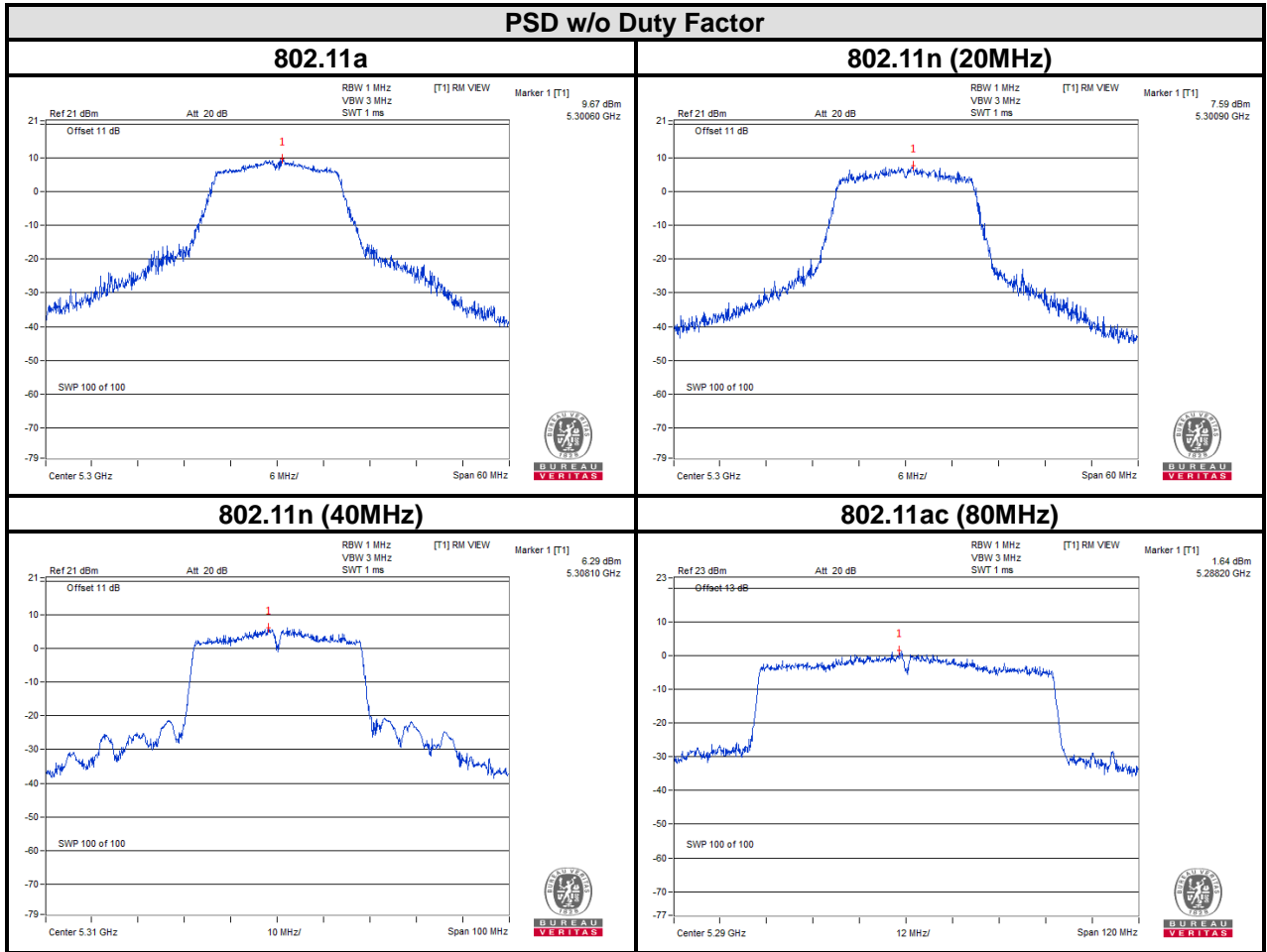



BUREAU VERITAS

Test Report No.: RF190326W003-3

For 5500~5700MHz

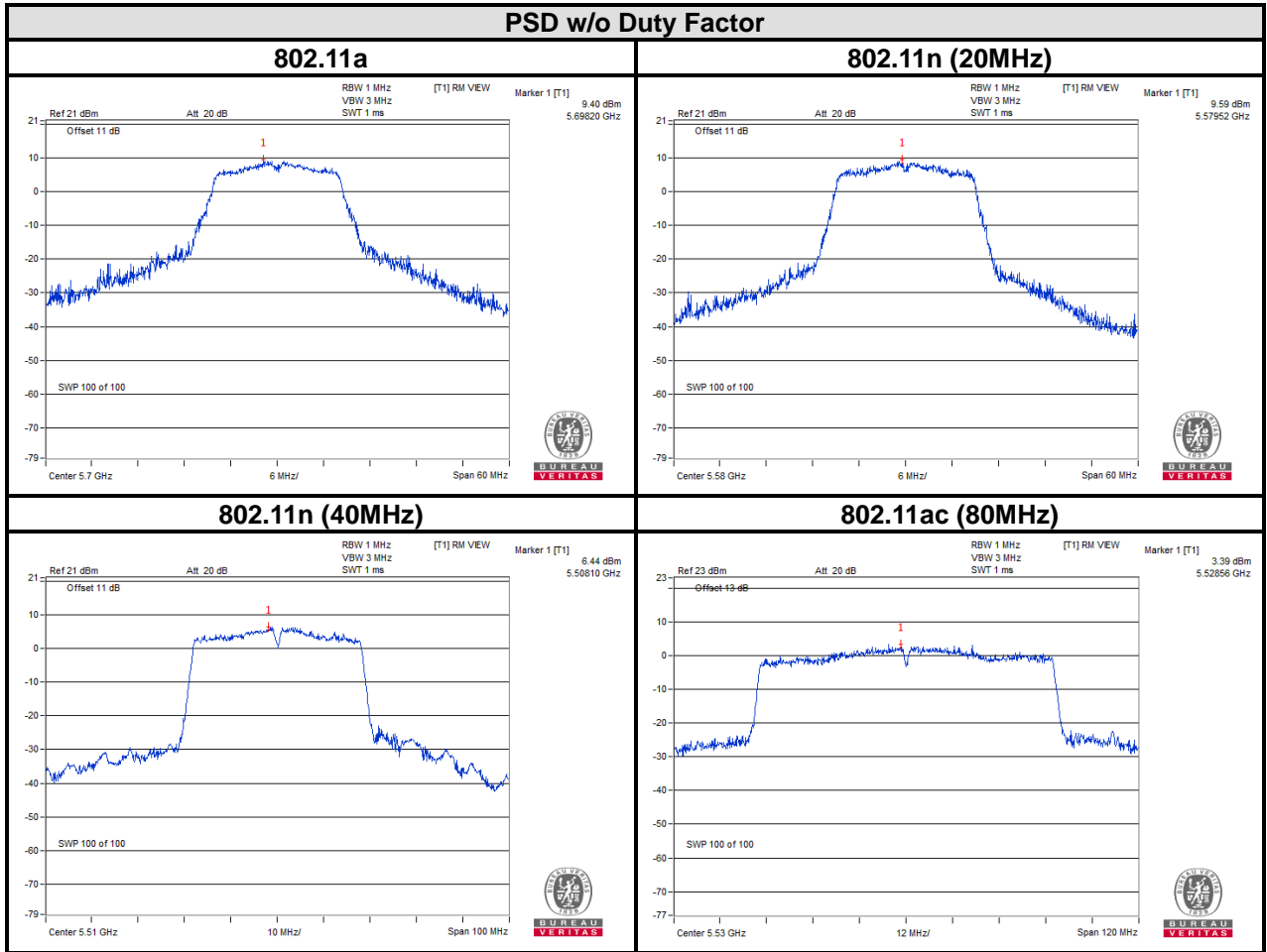



BUREAU VERITAS

Test Report No.: RF190326W003-3

For 5745~5825MHz

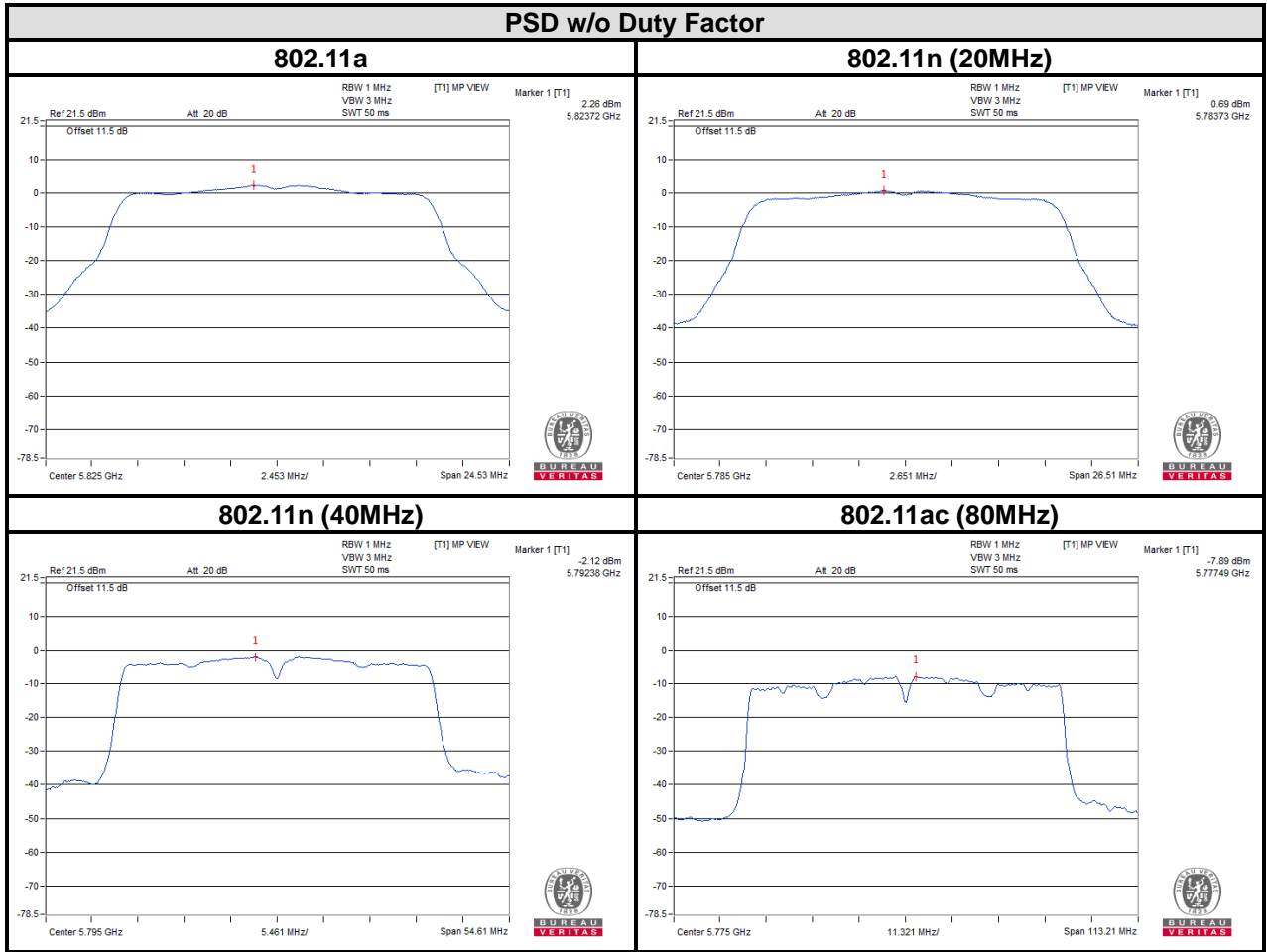



3.5 FREQUENCY STABILITY

3.5.1 LIMITS OF FREQUENCY STABILITY MEASUREMENT

The frequency of the carrier signal shall be maintained within band of operation

3.5.2 TEST SETUP

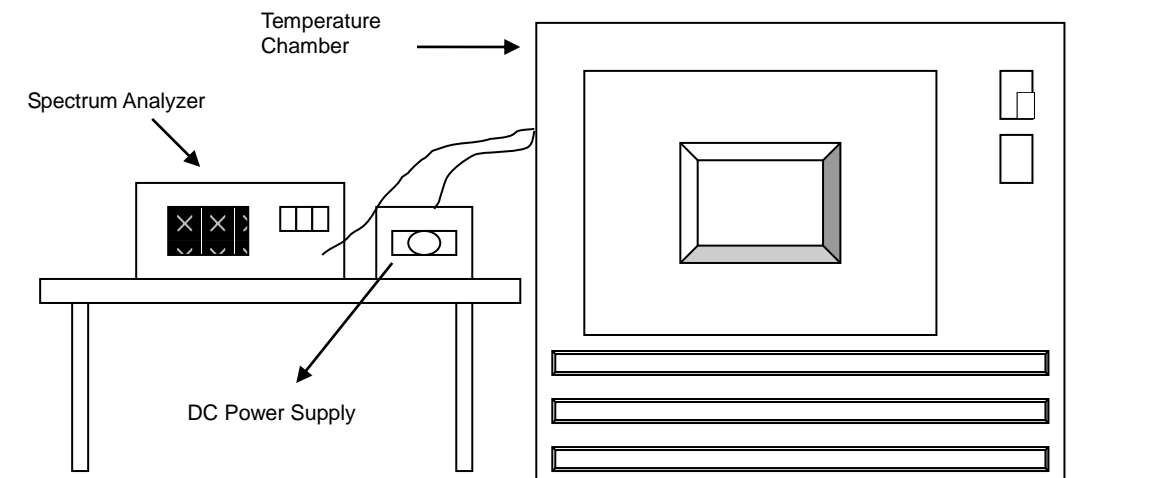

3.5.3 TEST INSTRUMENTS

Refer to section 3.3.3 to get information of above instrument.



3.5.4 TEST PROCEDURE

- a. The EUT was placed inside the environmental test chamber and powered by nominal DC voltage.
- b. Turn the EUT on and couple its output to a spectrum analyzer.
- c. Turn the EUT off and set the chamber to the highest temperature specified.
- d. Allow sufficient time (approximately 30 min) for the temperature of the chamber to stabilize, turn the EUT on and measure the operating frequency after 2, 5, and 10 minutes.
- e. Repeat step 2 and 3 with the temperature chamber set to the lowest temperature.
- f. The test chamber was allowed to stabilize at +20 degree C for a minimum of 30 minutes. The supply voltage was then adjusted on the EUT from 85% to 115% and the frequency record.

3.5.5 DEVIATION FROM TEST STANDARD

No deviation.

3.5.6 EUT OPERATING CONDITION

Set the EUT transmit at un-modulation mode to test frequency stability.



3.5.7 TEST RESULTS

FREQUENCY STABILITY VERSUS TEMP.										
OPERATING FREQUENCY: 5180MHz										
TEMP. (°C)	Power Supply (Vdc)	0 MINUTE		2 MINUTES		5 MINUTES		10 MINUTE		RESULT
		Measured Frequency (MHz)	Frequency Drift (ppm)	Measured Frequency (MHz)	Frequency Drift (ppm)	Measured Frequency (MHz)	Frequency Drift (ppm)	Measured Frequency (MHz)	Frequency Drift (ppm)	
50	120	5180.0006	0.116	5180.0091	1.757	5180.0049	0.946	5180.0083	1.602	PASS
40	120	5179.9964	-0.695	5179.9961	-0.753	5179.9967	-0.637	5180.003	0.579	PASS
30	120	5179.9872	-2.471	5179.988	-2.317	5179.9827	-3.340	5179.9841	-3.069	PASS
20	120	5180.0209	4.035	5180.0225	4.344	5180.0174	3.359	5180.0222	4.286	PASS
10	120	5180.0087	1.680	5180.0163	3.147	5180.0118	2.278	5180.0185	3.571	PASS
0	120	5179.9761	-4.614	5179.9721	-5.386	5179.9703	-5.734	5179.9772	-4.402	PASS
-10	120	5180.0142	2.741	5180.0124	2.394	5180.0079	1.525	5180.0142	2.741	PASS
-20	120	5180.0159	3.069	5180.014	2.703	5180.0123	2.375	5180.0098	1.892	PASS
-30	120	5179.9752	-4.788	5179.9778	-4.286	5179.982	-3.475	5179.9768	-4.479	PASS

FREQUENCY STABILITY VERSUS VOLTAGE										
OPERATING FREQUENCY: 5180MHz										
TEMP. (°C)	Power Supply (Vdc)	0 MINUTE		2 MINUTE		5 MINUTE		10 MINUTE		RESULT
		Measured Frequency (MHz)	Frequency Drift (ppm)	Measured Frequency (MHz)	Frequency Drift (ppm)	Measured Frequency (MHz)	Frequency Drift (ppm)	Measured Frequency (MHz)	Frequency Drift (ppm)	
20	138	5180.0211	4.073	5180.0234	4.517	5180.017	3.282	5180.0234	4.517	PASS
	120	5180.0209	4.035	5180.0225	4.344	5180.0174	3.359	5180.0222	4.286	PASS
	102	5180.0202	3.900	5180.0241	4.653	5180.017	3.282	5180.0219	4.228	PASS



FREQUENCY STABILITY VERSUS TEMP.										
OPERATING FREQUENCY: 5825MHz										
TEMP. (°C)	Power Supply (Vdc)	0 MINUTE		2 MINUTES		5 MINUTES		10 MINUTE		RESULT
		Measured Frequency (MHz)	Frequency Drift (ppm)	Measured Frequency (MHz)	Frequency Drift (ppm)	Measured Frequency (MHz)	Frequency Drift (ppm)	Measured Frequency (MHz)	Frequency Drift (ppm)	
50	120	5825.0111	1.906	5825.0117	2.009	5825.0113	1.940	5825.0168	2.884	PASS
40	120	5825.016	2.747	5825.0195	3.348	5825.0113	1.940	5825.0097	1.665	PASS
30	120	5825.03	5.150	5825.0314	5.391	5825.0314	5.391	5825.027	4.635	PASS
20	120	5825.019	3.262	5825.0132	2.266	5825.0234	4.017	5825.0147	2.524	PASS
10	120	5825.0302	5.185	5825.0214	3.674	5825.0201	3.451	5825.023	3.948	PASS
0	120	5824.9877	-2.112	5824.988	-2.060	5824.986	-2.403	5824.9821	-3.073	PASS
-10	120	5825.0015	0.258	5824.9933	-1.150	5824.9928	-1.236	5824.9916	-1.442	PASS
-20	120	5824.9896	-1.785	5824.9982	-0.309	5824.9869	-2.249	5824.986	-2.403	PASS
-30	120	5825.0166	2.850	5825.0233	4.000	5825.0208	3.571	5825.0184	3.159	PASS

FREQUENCY STABILITY VERSUS VOLTAGE										
OPERATING FREQUENCY: 5825MHz										
TEMP. (°C)	Power Supply (Vdc)	0 MINUTE		2 MINUTE		5 MINUTE		10 MINUTE		RESULT
		Measured Frequency (MHz)	Frequency Drift (ppm)	Measured Frequency (MHz)	Frequency Drift (ppm)	Measured Frequency (MHz)	Frequency Drift (ppm)	Measured Frequency (MHz)	Frequency Drift (ppm)	
20	138	5825.0187	3.210	5825.0147	2.524	5825.023	3.948	5825.0143	2.455	PASS
	120	5825.019	3.262	5825.0132	2.266	5825.0234	4.017	5825.0147	2.524	PASS
	102	5825.0182	3.124	5825.0132	2.266	5825.0233	4.000	5825.0135	2.318	PASS



Test Report No.: RF190326W003-3

4 PHOTOGRAPHS OF THE TEST CONFIGURATION

Please refer to the attached file (Test Setup Photo).



5 APPENDIX A – MODIFICATIONS RECORDERS FOR ENGINEERING CHANGES TO THE EUT BY THE LAB

No modifications were made to the EUT by the lab during the test.

---END---