

FCC REPORT

(LTE)

Applicant: PAX Technology Limited

Address of Applicant: Room 2416, 24/F., Sun Hung Kai Centre, 30 Harbour Road, Wanchai, Hong Kong

Equipment Under Test (EUT)

Product Name: Communication Module

Model No.: CM20

Trade mark: PAX

FCC ID: V5PCM204GW

Applicable standards: FCC CFR Title 47 Part 2
FCC CFR Title 47 Part 22 Subpart H
FCC CFR Title 47 Part 24 Subpart E
FCC CFR Title 47 Part 27 Subpart L
FCC CFR Title 47 Part 27 Subpart F
FCC CFR Title 47 Part 27 Subpart H
FCC CFR Title 47 Part 27 Subpart N

Date of sample receipt: 23 Aug., 2019

Date of Test: 24 Aug., to 16 Sep., 2019

Date of report issued: 18 Oct., 2019

Test Result: PASS*

*In the configuration tested, the EUT complied with the standards specified above.

Authorized Signature:



Bruce Zhang
Laboratory Manager

This report details the results of the testing carried out on one sample. The results contained in this test report do not relate to other samples of the same product and does not permit the use of the CCIS product certification mark. The manufacturer should ensure that all products in series production are in conformity with the product sample detailed in this report.

This report may only be reproduced and distributed in full. If the product in this report is used in any configuration other than that detailed in the report, the manufacturer must ensure the new system complies with all relevant standards.

This document cannot be reproduced except in full, without prior written approval of the Company. Any unauthorized alteration, forgery or falsification of the content or appearance of this document is unlawful, and offenders may be prosecuted to the fullest extent of the law. Unless otherwise stated the results shown in this test report refer only to the sample(s) tested and such sample(s) are retained for 90 days only.

2. Version

Version No.	Date	Description
00	17 Sep., 2019	Original
00	18 Oct., 2019	Original

Tested by:

Mike.ou

Date:

18 Oct., 2019

Test Engineer

Reviewed by:

Winner Zhang

Date:

18 Oct., 2019

Project Engineer

3. Contents

	Page
1. COVER PAGE	1
2. VERSION	2
3. CONTENTS	3
4. TEST SUMMARY	4
5. GENERAL INFORMATION	5
5.1 CLIENT INFORMATION.....	5
5.2 GENERAL DESCRIPTION OF E.U.T.....	5
5.3 TEST ENVIRONMENT AND MODE	15
5.4 DESCRIPTION OF SUPPORT UNITS.....	15
5.5 MEASUREMENT UNCERTAINTY.....	15
5.6 RELATED SUBMITTAL(S) / GRANT (S).....	15
5.7 LABORATORY FACILITY.....	15
5.8 LABORATORY LOCATION	15
5.9 TEST INSTRUMENTS LIST.....	16
6. TEST RESULTS	17
6.1 CONDUCTED OUTPUT POWER, ERP AND EIRP	17
6.2 PEAK-TO-AVERAGE RATIO.....	21
6.3 OCCUPY BANDWIDTH.....	22
6.4 OUT OF BAND EMISSION AT ANTENNA TERMINALS	23
6.5 FIELD STRENGTH OF SPURIOUS RADIATION MEASUREMENT.....	24
6.6 FREQUENCY STABILITY V.S. TEMPERATURE MEASUREMENT.....	41
6.7 FREQUENCY STABILITY V.S. VOLTAGE MEASUREMENT	42
7 TEST SETUP PHOTO	43
8 EUT CONSTRUCTIONAL DETAILS	44

4. Test Summary

Test Items	Section in CFR 47	Result
RF Exposure (SAR)	Part 1.1310 Part 2.1091	Passed (Please refer to MPE Report)
RF Output Power	Part 2.1046 Part 22.913 (a)(5) Part 24.232 (c) Part 27.50 (c)(10) Part 27.50 (d)(4) Part 27.50 (h)(2) Part 27.50 (b)(10)	Pass*
Peak-to-Average Ratio	Part 24.232 (d) Part 27.50(d)(5)	Pass*
Modulation Characteristics	Part 2.1047	Pass*
99% & -26 dB Occupied Bandwidth	Part 2.1049 Part 22.917(b) Part 24.238(b) Part 27.53(g) Part 27.53(h) Part 27.53(c)(2)(4)	Pass*
Out of band emission at antenna terminals	Part 2.1053 Part 22.917(a) Part 24.238 (a) Part 27.53 (g) Part 27.53 (h) Part 27.53(c)(2)	Pass*
Field strength of spurious radiation	Part 22.917(a) Part 24.238 (a) Part 27.53 (g) Part 27.53 (h) Part 27.53(c)(2)(4)	Pass
Frequency stability vs. temperature	Part 22.355 Part 24.235 Part 27.54 Part 2.1055(a)(1)(b)	Pass*
Frequency stability vs. voltage	Part 22.355 Part 24.235 Part 27.54 Part 2.1055(d)(2)	Pass*

Pass: The EUT complies with the essential requirements in the standard.

Pass: please refer to FCC ID: ZMONL668AM00, Report No.: FG801914-01B.*

5. General Information

5.1 Client Information

Applicant:	PAX Technology Limited
Address:	Room 2416, 24/F., Sun Hung Kai Centre, 30 Harbour Road, Wanchai, Hong Kong
Manufacturer:	PAX Computer Technology (Shenzhen) Co., Ltd.
Address:	401-402 No.3 Building, Software Park, Nanshandistrict, Shenzhen, Guangdong, P.R.C.

5.2 General Description of E.U.T.

Product Name:	Communication Module
Model No.:	CM20
Operation Frequency range:	LTE Band 2: TX: 1850MHz-1910MHz, RX: 1930MHz-1990MHz LTE Band 4: TX: 1710MHz-1755MHz, RX: 2110MHz-2155MHz LTE Band 5: 824MHz-849MHz, RX: 869MHz-894MHz LTE Band 12: TX: 699MHz-716MHz, RX: 729MHz-746MHz LTE Band 13: TX: 777MHz-787MHz, RX: 746MHz-756MHz LTE Band 17: TX: 704MHz-716MHz, RX: 734MHz-746MHz LTE Band 66: TX: 1710MHz-1780MHz, RX: 2110MHz-2200MHz LTE Band 71: TX: 663MHz-698MHz, RX: 617MHz-652MHz
Modulation type:	QPSK, 16QAM
Antenna type:	External Antenna
Antenna gain:	LTE Band 2: 1.0 dBi LTE Band 4: 1.0 dBi LTE Band 5: 0.5 dBi LTE Band 12: 0.5 dBi LTE Band 13: 0.5 dBi LTE Band 17: 0.5 dBi LTE Band 66: 0.5 dBi LTE Band 71: 0.5 dBi
Power supply:	Model No.: GLH0901000 Input: AC100-240V, 50/60Hz 0.5 A Output: DC 9.0V, 1.0A
Test Sample Condition:	The applicant provided engineering samples for staying in continuously transmitting for testing.

Operation Frequency List:

LTE Band 2 (1.4MHz)		LTE Band 2 (3MHz)	
Channel	Frequency (MHz)	Channel	Frequency (MHz)
18607	1850.70	18615	1851.50
18608	1850.80	18616	1851.60
....
18899	1879.90	18899	1879.90
18900	1880.00	18900	1880.00
18901	1880.10	18901	1880.10
...
19193	1909.20	19185	1908.40
19194	1909.30	19186	1908.50
LTE Band 2 (5MHz)		LTE Band 2 (10MHz)	
Channel	Frequency (MHz)	Channel	Frequency (MHz)
18625	1852.50	18650	1855.00
18626	1852.60	18651	1855.10
....
18899	1879.90	18899	1879.90
18900	1880.00	18900	1880.00
18901	1880.10	18901	1880.10
...
19175	1907.40	19150	1904.90
19176	1907.50	19151	1905.00
LTE Band 2 (15MHz)		LTE Band 2 (20MHz)	
Channel	Frequency (MHz)	Channel	Frequency (MHz)
18675	1857.50	18700	1860.00
18676	1857.60	18701	1860.10
....
18899	1879.90	18899	1879.90
18900	1880.00	18900	1880.00
18901	1880.10	18901	1880.10
...
19125	1902.40	19100	1899.90
19126	1902.50	19101	1900.00

LTE Band 4 (1.4MHz)		LTE Band 4 (3MHz)	
Channel	Frequency (MHz)	Channel	Frequency (MHz)
19957	1710.70	19965	1711.50
19958	1710.80	19966	1711.60
....
20174	1732.40	20174	1732.40
20175	1732.50	20175	1732.50
20176	1732.60	20176	1732.60
...
20392	1754.20	20384	1753.40
20393	1754.30	20385	1753.50
LTE Band 4 (5MHz)		LTE Band 4 (10MHz)	
Channel	Frequency (MHz)	Channel	Frequency (MHz)
19975	1712.50	20000	1715.00
19976	1712.60	20001	1715.10
....
20174	1732.40	20174	1732.40
20175	1732.50	20175	1732.50
20176	1732.60	20176	1732.60
...
20374	1752.40	20349	1749.90
20375	1752.50	20350	1750.00
LTE Band 4 (15MHz)		LTE Band 4 (20MHz)	
Channel	Frequency (MHz)	Channel	Frequency (MHz)
20025	1717.50	20050	1720.00
20026	1717.60	20051	1720.10
....
20174	1732.40	20174	1732.40
20175	1732.50	20175	1732.50
20176	1732.60	20176	1732.60
...
20324	1747.40	20299	1744.90
20325	1747.50	20300	1745.00

LTE Band 5 (1.4MHz)		LTE Band 5 (3MHz)	
Channel	Frequency (MHz)	Channel	Frequency (MHz)
20407	824.70	20415	825.50
20408	824.80	20416	825.60
....
20524	836.40	20524	836.40
20525	836.50	20525	836.50
20526	836.60	20526	836.60
...
20642	848.20	20634	847.40
20643	848.30	20635	847.50
LTE Band 5 (5MHz)		LTE Band 5 (10MHz)	
Channel	Frequency (MHz)	Channel	Frequency (MHz)
20425	826.50	20450	829.00
20426	826.60	20451	829.10
....
20524	836.40	20524	836.40
20525	836.50	20525	836.50
20526	836.60	20526	836.60
...
20624	846.40	20599	839.90
20625	846.50	20600	844.00

LTE Band 12 (1.4MHz)		LTE Band 12 (3MHz)	
Channel	Frequency (MHz)	Channel	Frequency (MHz)
23017	699.70	23025	700.50
23756	699.80	23026	700.60
....
23094	707.40	23094	707.40
23095	707.50	23095	707.50
23096	707.60	23096	707.60
...
23172	715.20	23164	714.40
23173	715.30	23165	714.50
LTE Band 12 (5MHz)		LTE Band 12 (10MHz)	
Channel	Frequency (MHz)	Channel	Frequency (MHz)
23035	701.50	23060	704.00
23036	701.60	23061	704.10
....
23094	707.40	23094	707.40
23095	707.50	23095	707.50
23096	707.60	23096	707.60
...
23154	713.40	23129	710.90
23155	713.50	23130	711.00

LTE Band 13 (5MHz)		LTE Band 13 (10MHz)	
Channel	Frequency (MHz)	Channel	Frequency (MHz)
23205	779.50	23230	782
....		
23230	782.00		
....		
23255	784.50		

LTE Band 17 (5MHz)		LTE Band 17 (10MHz)	
Channel	Frequency (MHz)	Channel	Frequency (MHz)
23755	706.50	23780	709.00
23756	706.60	23781	709.10
....
23789	709.90	23789	709.90
23790	710.00	23790	710.00
23791	710.10	23791	710.10
...
23824	713.40	23799	710.90
23825	713.50	23800	711.00

LTE Band 66 (1.4MHz)		LTE Band 66 (3MHz)	
Channel	Frequency (MHz)	Channel	Frequency (MHz)
131979	1710.70	131987	1711.50
131980	1710.80	131988	1711.60
....
132321	1744.90	132321	1744.90
132322	1745.00	132322	1745.00
132323	1745.10	132323	1745.10
...
132664	1779.20	132656	1778.40
132665	1779.30	132657	1778.50
LTE Band 66 (5MHz)		LTE Band 66 (10MHz)	
Channel	Frequency (MHz)	Channel	Frequency (MHz)
131997	1712.50	132022	1715.00
131998	1712.60	132023	1715.10
....
132321	1744.90	132321	1744.90
132322	1745.00	132322	1745.00
132323	1745.10	132323	1745.10
...
136246	1777.40	132621	1774.90
136247	1777.50	132622	1775.00
LTE Band 66 (15MHz)		LTE Band 66 (20MHz)	
Channel	Frequency (MHz)	Channel	Frequency (MHz)
18675	1857.50	18700	1860.00
18676	1857.60	18701	1860.10
....
132321	1744.90	132321	1744.90
132322	1745.00	132322	1745.00
132323	1745.10	132323	1745.10
...
19125	1902.40	19100	1899.90
19126	1902.50	19101	1900.00

LTE Band 71 (5MHz)		LTE Band 71 (10MHz)	
Channel	Frequency (MHz)	Channel	Frequency (MHz)
134122	673.00	133872	670.50
134123	673.10	133873	670.60
....
133296	680.40	133296	680.40
133297	680.50	133297	680.50
133298	680.60	133298	680.60
...
133371	687.90	133396	690.40
133372	688.00	133397	690.50
LTE Band 71 (15MHz)		LTE Band 71 (20MHz)	
Channel	Frequency (MHz)	Channel	Frequency (MHz)
133622	668.00	133372	665.50
133623	668.10	133371	655.60
....
133296	680.40	133296	680.40
133297	680.50	133297	680.50
133298	680.60	133298	680.60
...
133421	692.90	133446	695.40
133422	693.00	133447	695.50

Regards to the operating frequency range, the lowest frequency, the middle frequency, and the highest frequency of channel were selected to perform the test, and the selected channels as below:

LTE Band 2 (1.4MHz)			LTE Band 2 (3MHz)		
Channel		Frequency (MHz)	Channel		Frequency (MHz)
Lowest channel	18607	1850.70	Lowest channel	18615	1851.50
Middle channel	18900	1880.00	Middle channel	18900	1880.00
Highest channel	19193	1909.30	Highest channel	19185	1908.50
LTE Band 2 (5MHz)			LTE Band 2 (10MHz)		
Channel		Frequency (MHz)	Channel		Frequency (MHz)
Lowest channel	18625	1852.50	Lowest channel	18650	1855.00
Middle channel	18900	1880.00	Middle channel	18900	1880.00
Highest channel	19175	1907.50	Highest channel	19150	1905.00
LTE Band 2 (15MHz)			LTE Band 2 (20MHz)		
Channel		Frequency (MHz)	Channel		Frequency (MHz)
Lowest channel	18675	1857.50	Lowest channel	18700	1860.00
Middle channel	18900	1880.00	Middle channel	18900	1880.00
Highest channel	19125	1902.50	Highest channel	19100	1900.00

LTE Band 4 (1.4MHz)			LTE Band 4 (3MHz)		
Channel:		Frequency (MHz)	Channel		Frequency (MHz)
Lowest channel	19957	1710.70	Lowest channel	19965	1711.50
Middle channel	20175	1732.50	Middle channel	20175	1732.50
Highest channel	20393	1754.30	Highest channel	20385	1753.50
LTE Band 4 (5MHz)			LTE Band 4 (10MHz)		
Channel		Frequency (MHz)	Channel		Frequency (MHz)
Lowest channel	19975	1712.50	Lowest channel	20000	1715.00
Middle channel	20175	1732.50	Middle channel	20175	1732.50
Highest channel	20375	1752.50	Highest channel	20350	1750.00
LTE Band 4 (15MHz)			LTE Band 4 (20MHz)		
Channel		Frequency (MHz)	Channel		Frequency (MHz)
Lowest channel	20025	1717.50	Lowest channel	20050	1720.00
Middle channel	20175	1732.50	Middle channel	20175	1732.50
Highest channel	20325	1747.50	Highest channel	20300	1745.00

LTE Band 5 (1.4MHz)			LTE Band 5 (3MHz)		
Channel:		Frequency (MHz)	Channel		Frequency (MHz)
Lowest channel	20407	824.70	Lowest channel	20415	825.50
Middle channel	20525	836.50	Middle channel	20525	836.50
Highest channel	20643	848.30	Highest channel	20635	847.50
LTE Band 5 (5MHz)			LTE Band 5 (10MHz)		
Channel		Frequency (MHz)	Channel		Frequency (MHz)
Lowest channel	20425	826.50	Lowest channel	20450	829.00
Middle channel	20525	836.50	Middle channel	20525	836.50
Highest channel	20625	846.50	Highest channel	20600	844.00

LTE Band 12(1.4MHz)			LTE Band 12(3MHz)		
Channel	Frequency (MHz)		Channel	Frequency (MHz)	
Lowest channel	23017	699.70	Lowest channel	23025	700.50
Middle channel	23095	707.50	Middle channel	23095	707.50
Highest channel	23173	715.30	Highest channel	23165	714.50
LTE Band 12(5MHz)			LTE Band 12(10MHz)		
Channel	Frequency (MHz)		Channel	Frequency (MHz)	
Lowest channel	23035	701.50	Lowest channel	23060	704.00
Middle channel	23095	707.50	Middle channel	23095	707.50
Highest channel	23155	713.50	Highest channel	23130	711.00

LTE Band 13(5MHz)			LTE Band 13(10MHz)		
Channel	Frequency (MHz)		Channel	Frequency (MHz)	
Lowest channel	23205	779.5	Lowest channel		
Middle channel	23230	782.0	Middle channel	23230	782.00
Highest channel	23255	784.5	Highest channel		

LTE Band 17(5MHz)			LTE Band 17(10MHz)		
Channel	Frequency (MHz)		Channel	Frequency (MHz)	
Lowest channel	23755	706.50	Lowest channel	23780	709.00
Middle channel	23790	710.00	Middle channel	23790	710.00
Highest channel	23825	713.50	Highest channel	23800	711.00

LTE Band 66 (1.4MHz)			LTE Band 66 (3MHz)		
Channel	Frequency (MHz)		Channel	Frequency (MHz)	
Lowest channel	131979	1710.7	Lowest channel	131987	1711.5
Middle channel	132322	1745.0	Middle channel	132322	1745.0
Highest channel	132665	1779.3	Highest channel	132657	1778.5
LTE Band 66 (5MHz)			LTE Band 66 (10MHz)		
Channel	Frequency (MHz)		Channel	Frequency (MHz)	
Lowest channel	131997	1712.5	Lowest channel	132022	1715.0
Middle channel	132322	1745.5	Middle channel	132322	1745.0
Highest channel	132647	1777.5	Highest channel	132622	1775.0
LTE Band 66 (15MHz)			LTE Band 66 (20MHz)		
Channel	Frequency (MHz)		Channel	Frequency (MHz)	
Lowest channel	132047	1717.5	Lowest channel	132072	1720.0
Middle channel	132322	1745.0	Middle channel	132322	1745.0
Highest channel	132597	1772.5	Highest channel	132572	1770.0

LTE Band 71 (5MHz)			LTE Band 71 (10MHz)		
Channel		Frequency (MHz)	Channel		Frequency (MHz)
Lowest channel	134122	673.0	Lowest channel	133872	670.5
Middle channel	133297	680.5	Middle channel	133297	680.5
Highest channel	133372	688.0	Highest channel	133397	690.5
LTE Band 71 (15MHz)			LTE Band 71 (20MHz)		
Channel		Frequency (MHz)	Channel		Frequency (MHz)
Lowest channel	133622	668.0	Lowest channel	133372	665.5
Middle channel	133297	680.5	Middle channel	133297	680.5
Highest channel	133422	693.0	Highest channel	133447	695.5

5.3 Test environment and mode

Operating Environment:	
Temperature:	Normal: 15°C ~ 35°C, Extreme: -30°C ~ +50°C
Humidity:	20 % ~ 75 % RH
Atmospheric Pressure:	1008 mbar
Voltage:	Nominal: 120Vac, Extreme: Low 102Vac, High 138Vac
Test mode:	
LTE QPSK mode	Keep the EUT communication with simulated station in QPSK mode
LTE 16-QAM mode	Keep the EUT communication with simulated station in 16-QAM mode
Remark: The EUT has been tested under continuous transmitting mode. Channel Low, Mid and High for each type band with rated data rate were chosen for full testing. The field strength of spurious radiation emission was measured as EUT stand-up position (H mode) and lie down position (E1, E2 mode) for these modes with power adaptor, earphone and Data cable. Just the worst case position (H mode) shown in report.	

5.4 Description of Support Units

Test Equipment	Manufacturer	Model No.	Serial No.
Simulated Station	Anritsu	MT8820C	6201026545

5.5 Measurement Uncertainty

Parameters	Expanded Uncertainty
Radiated Emission (9kHz ~ 30MHz)	±3.12 dB (k=2)
Radiated Emission (30MHz ~ 1000MHz)	±4.32 dB (k=2)
Radiated Emission (1GHz ~ 18GHz)	±5.38 dB (k=2)
Radiated Emission (18GHz ~ 40GHz)	±3.36 dB (k=2)

5.6 Related Submittal(s) / Grant (s)

This is an original grant, no related submittals and grants.
--

5.7 Laboratory Facility

<p>The test facility is recognized, certified, or accredited by the following organizations:</p> <ul style="list-style-type: none"> ● FCC - Designation No.: CN1211 Shenzhen Zhongjian Nanfang Testing Co., Ltd. has been accredited as a testing laboratory by FCC (Federal Communications Commission). The test firm Registration No. is 727551. ● ISED – CAB identifier.: CN0021 The 3m Semi-anechoic chamber of Shenzhen Zhongjian Nanfang Testing Co., Ltd. has been Registered by Certification and Engineering Bureau of Industry Canada for radio equipment testing with Registration No.: 10106A-1. ● CNAS - Registration No.: CNAS L6048 Shenzhen Zhongjian Nanfang Testing Co., Ltd. is accredited to ISO/IEC 17025:2005 General Requirements for the Competence of Testing and Calibration laboratories for the competence of testing. The Registration No. is CNAS L6048. ● A2LA - Registration No.: 4346.01 This laboratory is accredited in accordance with the recognized International Standard ISO/IEC 17025:2005 General requirements for the competence of testing and calibration laboratories. The test scope can be found as below link: https://portal.a2la.org/scopepdf/4346-01.pdf

5.8 Laboratory Location

<p>Shenzhen Zhongjian Nanfang Testing Co., Ltd. Address: No. B-C, 1/F., Building 2, Laodong No.2 Industrial Park, Xixiang Road, Bao'an District, Shenzhen, Guangdong, China Tel: +86-755-23118282, Fax: +86-755-23116366 Email: info@ccis-cb.com, Website: http://www.ccis-cb.com</p>

5.9 Test Instruments list

Test Equipment	Manufacturer	Model No.	Serial No.	Cal. Date (mm-dd-yy)	Cal. Due date (mm-dd-yy)
3m SAC	SAEMC	9m*6m*6m	966	07-22-2017	07-21-2020
BiConiLog Antenna	SCHWARZBECK	VULB9163	497	03-18-2019	03-17-2020
Biconical Antenna	SCHWARZBECK	VUBA9117	359	06-22-2017	06-21-2020
Horn Antenna	SCHWARZBECK	BBHA9120D	916	03-18-2019	03-17-2020
Horn Antenna	SCHWARZBECK	BBHA9120D	1805	06-22-2017	06-21-2020
Horn Antenna	SCHWARZBECK	BBHA 9170	BBHA9170582	11-21-2018	11-20-2019
EMI Test Software	AUDIX	E3	Version: 6.110919b		
Pre-amplifier	HP	8447D	2944A09358	03-18-2019	03-17-2020
Pre-amplifier	CD	PAP-1G18	11804	03-18-2019	03-17-2020
Spectrum analyzer	Rohde & Schwarz	FSP30	101454	03-18-2019	03-17-2020
EMI Test Receiver	Rohde & Schwarz	ESRP7	101070	03-18-2019	03-17-2020
Spectrum Analyzer	Agilent	N9020A	MY50510123	10-29-2018	10-28-2019
Signal Generator	Rohde & Schwarz	SMX	835454/016	03-18-2019	03-17-2020
Signal Generator	R&S	SMR20	1008100050	03-18-2019	03-17-2020
RF Switch Unit	MWRFTTEST	MW200	N/A	N/A	N/A
Test Software	MWRFTTEST	MTS8200	Version: 2.0.0.0		
Cable	ZDECL	Z108-NJ-NJ-81	1608458	03-18-2019	03-17-2020
Cable	MICRO-COAX	MFR64639	K10742-5	03-18-2019	03-17-2020
Cable	SUHNER	SUCOFLEX100	58193/4PE	03-18-2019	03-17-2020
DC Power Supply	XinNuoEr	WYK-10020K	1409050110020	10-31-2018	10-30-2019
Temperature Humidity Chamber	HengPu	HPGDS-500	20140828008	09-24-2018	09-23-2019
Simulated Station	Rohde & Schwarz	CMW500	140493	07-16-2018	07-15-2019
				07-16-2019	07-15-2020

6. Test results

6.1 Conducted Output Power, ERP and EIRP

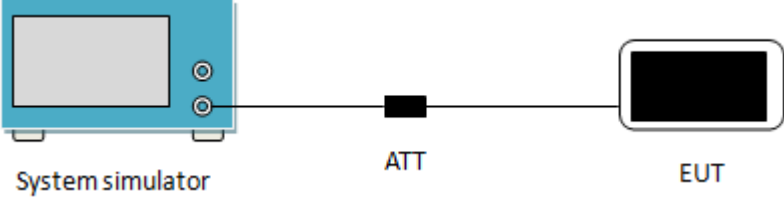
Test Requirement:	Part 22.913(a)(5), Part 24.232(c), part 27.50(c)(10), Part 27.50(d)(4), Part 27.50 (h)(2), Part 27.50 (b)(10)
Test Method:	ANSI/TIA-603-D 2010
Limit:	LTE Band 2: 2W, LTE Band 4: 1W, LTE Band 5: 7W, LTE Band 12: 3W, LTE Band 17: 3W, LTE Band 13: 3W, LTE Band 66: 1W, LTE Band 71: 3W
Test Setup:	 <p>The diagram illustrates the test setup. On the left is a blue 'System simulator' with a screen and two ports. A line connects it to a black 'ATT' (attenuator) block. Another line connects the 'ATT' to a black 'EUT' (Equipment Under Test) device.</p>
Test Procedure:	The transmitter output was connected to a calibrated attenuator, the other end of which was connected to the CMW500. Transmitter output power was read off in dBm.
Test Instruments:	Refer to section 5.9 for details
Test mode:	Refer to section 5.3 for details
Test results:	Max Conducted Output Power Refer to FCC ID: ZMONL668AM00, Report No.: FG8O1914-01B. Only retest ERP and EIRP

Measurement Data:

LTE Band	Bandwidth (MHz)	Modulation	Max Conducted Output Power(dBm)	Max. EIRP(dBm)	EIRP Limit (dBm)
2	1.4	QPSK	23.16	24.16	33
		16QAM	22.13	23.13	
	3	QPSK	23.03	24.03	
		16QAM	22.28	23.28	
	5	QPSK	23.22	24.22	
		16QAM	21.88	22.88	
	10	QPSK	23.17	24.17	
		16QAM	22.30	23.30	
	15	QPSK	23.22	24.22	
		16QAM	22.35	23.35	
	20	QPSK	23.31	24.31	
		16QAM	22.13	23.13	

Note: Max Conducted Output Power Refer to FCC ID: ZMONL668AM00, Report No.: FG801914-01B
 EIRP (dBm) = Average power (dBm) + Antenna Gain (dBi), Antenna Gain=1.0 dBi.

LTE Band	Bandwidth (MHz)	Modulation	Max Conducted Output Power(dBm)	Max. EIRP(dBm)	EIRP Limit (dBm)
4	1.4	QPSK	22.93	23.93	30
		16QAM	21.98	22.98	
	3	QPSK	23.00	24.00	
		16QAM	21.68	22.68	
	5	QPSK	23.00	24.00	
		16QAM	21.67	22.67	
	10	QPSK	23.03	24.03	
		16QAM	22.09	23.09	
	15	QPSK	23.06	24.06	
		16QAM	21.70	22.70	
	20	QPSK	23.07	24.07	
		16QAM	21.89	22.89	

Note: Max Conducted Output Power Refer to FCC ID: ZMONL668AM00, Report No.: FG801914-01B
 EIRP (dBm) = Average power (dBm) + Antenna Gain (dBi), Antenna Gain=1.0 dBi.

LTE Band	Bandwidth (MHz)	Modulation	Max Conducted Output Power(dBm)	Max. ERP(dBm)	ERP Limit (dBm)
5	1.4	QPSK	22.82	21.17	38.45
		16QAM	21.89	20.24	
	3	QPSK	22.76	21.11	
		16QAM	21.43	19.78	
	5	QPSK	22.75	21.10	
		16QAM	21.88	20.23	
	10	QPSK	22.86	21.21	
		16QAM	21.71	20.06	

Note: Max Conducted Output Power Refer to FCC ID: ZMONL668AM00, Report No.: FG801914-01B
 EIRP (dBm) = Average power (dBm) + Antenna Gain (dBi), Antenna Gain=0.5 dBi.
 ERP (dBm) = EIRP (dBm) - 2.15 (dB).

LTE Band	Bandwidth (MHz)	Modulation	Max Conducted Output Power(dBm)	Max. ERP(dBm)	ERP Limit (dBm)
12	1.4	QPSK	23.23	21.58	34.77
		16QAM	22.29	20.64	
	3	QPSK	23.28	21.63	
		16QAM	22.06	20.41	
	5	QPSK	23.24	21.59	
		16QAM	21.93	20.28	
10	QPSK	23.54	21.89		
	16QAM	22.56	20.91		

Note: Max Conducted Output Power Refer to FCC ID: ZMONL668AM00, Report No.: FG801914-01B
 EIRP (dBm) = Average power (dBm) + Antenna Gain (dBi), Antenna Gain=0.5dBi.
 ERP (dBm) = EIRP (dBm) - 2.15 (dB).

LTE Band	Bandwidth (MHz)	Modulation	Max Conducted Output Power(dBm)	Max. ERP(dBm)	EIRP Limit (dBm)
13	5	QPSK	23.20	21.55	34.77
		16QAM	22.04	20.39	
	10	QPSK	23.24	21.59	
		16QAM	22.06	20.41	

Note: Max Conducted Output Power Refer to FCC ID: ZMONL668AM00, Report No.: FG801914-01B
 EIRP (dBm) = Average power (dBm) + Antenna Gain (dBi), Antenna Gain=0.5dBi.
 ERP (dBm) = EIRP (dBm) - 2.15 (dB).

LTE Band	Bandwidth (MHz)	Modulation	Max Conducted Output Power(dBm)	Max. ERP(dBm)	ERP Limit (dBm)
17	5	QPSK	23.48	21.83	34.77
		16QAM	22.51	20.86	
	10	QPSK	23.50	21.85	
		16QAM	22.48	20.83	

Note: Max Conducted Output Power Refer to FCC ID: ZMONL668AM00, Report No.: FG801914-01B
 EIRP (dBm) = Average power (dBm) + Antenna Gain (dBi), Antenna Gain=0.5dBi.
 ERP (dBm) = EIRP (dBm) - 2.15 (dB).

LTE Band	Bandwidth (MHz)	Modulation	Max Conducted Output Power(dBm)	Max. EIRP(dBm)	EIRP Limit (dBm)
66	1.4	QPSK	23.36	23.86	30
		16QAM	22.43	22.93	
	3	QPSK	23.43	23.93	
		16QAM	22.41	22.91	
	5	QPSK	23.26	23.76	
		16QAM	22.21	22.71	
	10	QPSK	23.36	23.86	
		16QAM	22.75	23.25	
	15	QPSK	23.18	23.68	
		16QAM	22.16	22.66	
20	QPSK	23.63	24.13		
	16QAM	22.37	22.87		

Note: Max Conducted Output Power Refer to FCC ID: ZMONL668AM00, Report No.: FG801914-01B
 EIRP (dBm) = Average power (dBm) + Antenna Gain (dBi), Antenna Gain=0.5 dBi.

LTE Band	Bandwidth (MHz)	Modulation	Max Conducted Output Power(dBm)	Max. ERP(dBm)	ERP Limit (dBm)
71	5	QPSK	23.42	21.77	34.77
		16QAM	22.57	20.92	
	10	QPSK	23.71	22.06	
		16QAM	22.49	20.84	
	15	QPSK	23.65	22.00	
		16QAM	22.36	20.71	
	20	QPSK	23.87	22.22	
		16QAM	22.99	21.34	

Note: Max Conducted Output Power Refer to FCC ID: ZMONL668AM00, Report No.: FG801914-01B
 $EIRP (dBm) = Average\ power (dBm) + Antenna\ Gain (dBi)$, Antenna Gain=0.5 dBi.
 $ERP (dBm) = EIRP (dBm) - 2.15 (dB)$

6.2 Peak-to-Average Ratio

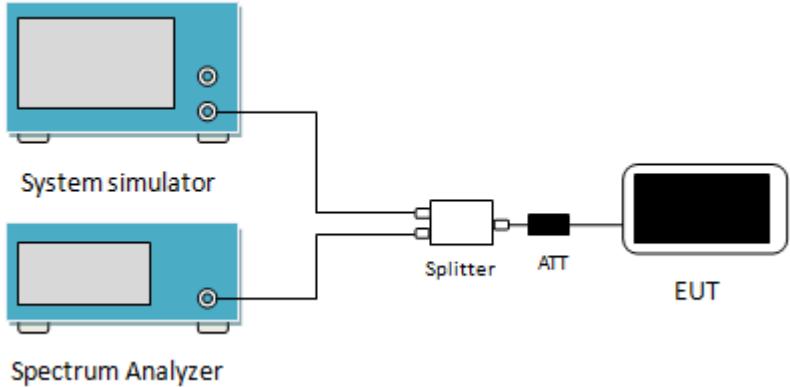
Test Requirement:	Part 24.232 (d), Part 27.50(d)(5)
Test Method:	ANSI C63.26-2015
Limit:	The peak-to-average ratio (PAR) of the transmission may not exceed 13 dB.
Test Setup:	 <p>The diagram illustrates the test setup. On the left, there are two blue rectangular units: the top one is labeled 'System simulator' and the bottom one is labeled 'Spectrum Analyzer'. Both have a screen and control knobs. A single cable connects the right side of the System simulator to the left side of the Spectrum Analyzer. From the right side of the Spectrum Analyzer, a cable goes to a white rectangular 'Splitter'. From the right side of the Splitter, a cable goes to a black rectangular 'ATT' (Attenuator). From the right side of the ATT, a cable goes to a black rectangular 'EUT' (Equipment Under Test).</p>
Test Procedure:	<ol style="list-style-type: none"> 1 The RF output of the transceiver was connected to a spectrum analyzer through appropriate attenuation. 2 Set the CCDF option in spectrum analyzer, $RBW \geq OBW$, 3 Set the EUT working in highest power level, measured and recorded the 0.1% as PAPR level. 4 Repeat step 1~3 at other frequency and modulations.
Test Instruments:	Refer to section 5.9 for details
Test mode:	Refer to section 5.3 for details
Test results:	Refer to FCC ID: ZMONL668AM00, Report No.: FG8O1914-01B.

6.3 Occupy Bandwidth

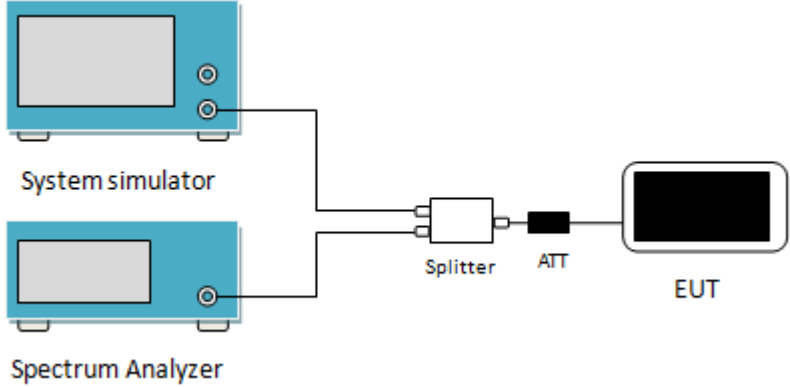
Test Requirement:	Part 22.917(b), Part 24.238(b), Part 27.53(g), Part 27.53(h), Part 27.53(c)(2)(4)
Test Method:	ANSI/TIA-603-D 2010
Test Setup:	 <p>The diagram illustrates the test setup. On the left, there are two blue rectangular units: the top one is labeled 'System simulator' and the bottom one is labeled 'Spectrum Analyzer'. Both have a screen and two ports on the right side. A single cable connects the two ports of the System simulator to the two ports of the Spectrum Analyzer. This cable then splits into two paths. One path goes to a 'Splitter' box, which has two outputs. One output of the Splitter goes to an 'ATT' (Attenuator) box, and the other goes to an 'EUT' (Equipment Under Test) box. The ATT and EUT boxes are connected in series.</p>
Test Procedure:	<ol style="list-style-type: none"> 1. The EUT's output RF connector was connected with a short cable to the spectrum analyzer 2. RBW was set to about 1% ~ 5% of emission BW, VBW= 3 times RBW. 3. -26dBc display line was placed on the screen (or 99% bandwidth), the occupied bandwidth is the delta frequency between the two points where the display line intersects the signal trace.
Test Instruments:	Refer to section 5.9 for details
Test mode:	Refer to section 5.3 for details
Test results:	Refer to FCC ID: ZMONL668AM00, Report No.: FG8O1914-01B.

6.4 Out of band emission at antenna terminals

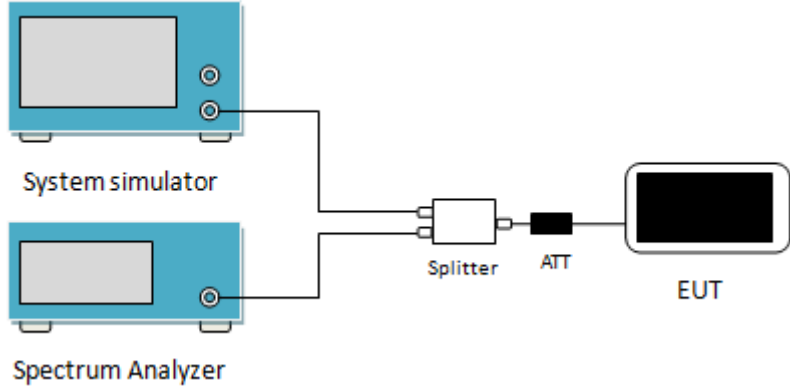
Test Requirement:	Part 22.917(a), Part 24.238 (a), Part 27.53 (g), Part 27.53 (h), Part 27.53(c)(2)
Test Method:	ANSI/TIA-603-D 2010
Limit:	LTE Band 2 & 4 & 5 & 12 & 13 & 17 & 66 & 71: The power of any emission outside a licensee's frequency block shall be attenuated below the transmitter power (P) in watts by at least $43 + 10 \log_{10}(P)$ dB (-13 dBm).
Test Setup:	 <p>The diagram shows a test setup. On the left, there are two blue rectangular units: the top one is labeled 'System simulator' and the bottom one is labeled 'Spectrum Analyzer'. Both have a circular port on their right side. These two ports are connected to a central white rectangular unit labeled 'Splitter'. From the right side of the 'Splitter', a line goes to a black rectangular unit labeled 'ATT' (Attenuator). From the right side of the 'ATT', a line goes to a white rectangular unit with a black screen, labeled 'EUT' (Equipment Under Test).</p>
Test Procedure:	<ol style="list-style-type: none"> 1 The RF output of the transceiver was connected to a spectrum analyzer through appropriate attenuation. 2 The resolution bandwidth of the spectrum analyzer was set at 100 kHz when below 1GHz, 1MHz when above 1 GHz; sufficient scans were taken to show the out of band Emissions if any up to 10th harmonic. 3 For the out of band: Set the RBW=100 kHz, VBW=300 kHz when below 1 GHz, RBW =1 MHz, VBW=3 MHz when above 1 GHz, Start=30MHz, Stop= 10th harmonic. 4 Band Edge Requirements: In the 1 MHz bands immediately outside and adjacent to the frequency block, a resolution bandwidth of at least 1 percent of the emission bandwidth of the fundamental emission of the transmitter may be employed to measure the out of band Emissions.
Test Instruments:	Refer to section 5.9 for details
Test mode:	Refer to section 5.3 for details
Test results:	Refer to FCC ID: ZMONL668AM00, Report No.: FG8O1914-01B.

6.5 Field strength of spurious radiation measurement

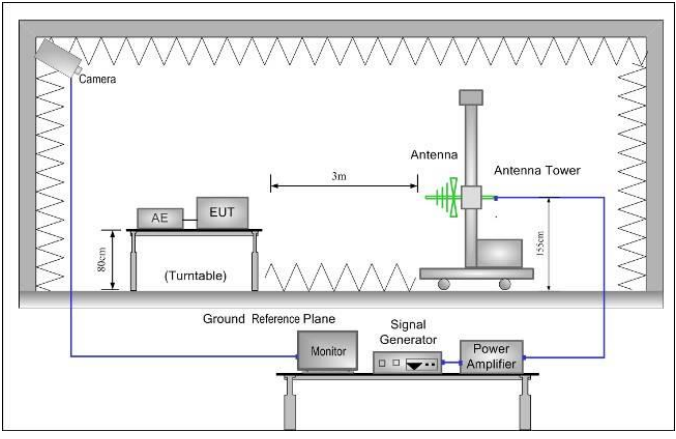
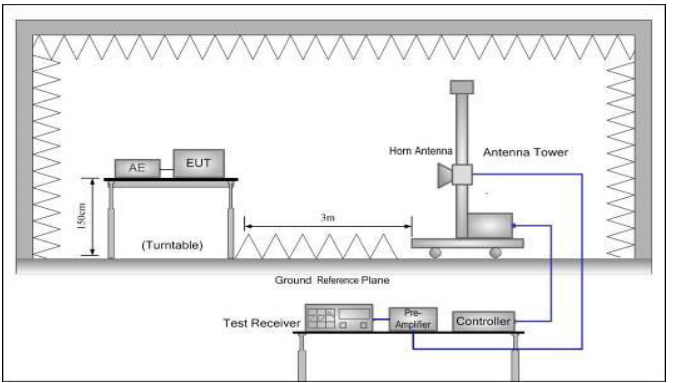
Test Requirement:	Part 22.917(a), Part 24.238 (a), Part 27.53 (g), Part 27.53 (h), Part 27.53(c)(2)(4)
Test Method:	ANSI/TIA-603-D 2010
Limit:	LTE Band 2 & 4 & 5 & 12 & 13 & 17 & 66 & 71: The power of any emission outside a licensee's frequency block shall be attenuated below the transmitter power (P) in watts by at least $43 + 10 \log_{10}(P)$ dB (-13 dBm).
Test setup:	<p>Below 1GHz</p>  <p>Above 1GHz</p> 
Test Procedure:	<ol style="list-style-type: none"> 1. The EUT was placed on an non-conductive turntable using a non-conductive support. The radiated emission at the fundamental frequency was measured at 3 m with a test antenna and EMI spectrum analyzer. 2. During the tests, the antenna height and the EUT azimuth were varied in order to identify the maximum level of emissions from the EUT. This maximization process was repeated with the EUT positioned in each of its three orthogonal orientations. 3. The frequency range up to tenth harmonic was investigated for each of three fundamental frequency (low, middle and high channels). Once spurious emission was identified, the power of the emission was determined using the substitution method. 4. The spurious emissions attenuation was calculated as the difference between radiated power at the fundamental frequency and the spurious emissions frequency. $ERP / EIRP = S.G. \text{ output (dBm)} + \text{Antenna Gain(dB/dBi)} - \text{Cable Loss (dB)}$
Test Instruments:	Refer to section 5.9 for details
Test mode:	Refer to section 5.3 for details.

Test results:	Passed
---------------	--------

Measurement Data:

LTE Band 2 part:

LTE Band 2, WB: 1.4MHz				
RB size 1 & RB offset 0				
Frequency (MHz)	Spurious Emission		Limit (dBm)	Result
	Polarization	Level (dBm)		
Lowest Channel				
3701.40	Vertical	-50.34	-13.00	Pass
5552.10	V	-43.27		
7402.00	V	-38.11		
3701.40	Horizontal	-49.42		
5552.10	H	-41.60		
7402.00	H	-38.75		
Middle Channel				
3760.00	Vertical	-50.16	-13.00	Pass
5640.00	V	-43.52		
7520.00	V	-38.09		
3760.00	Horizontal	-49.37		
5640.00	H	-46.26		
7520.00	H	-38.78		
Highest Channel				
3816.60	Vertical	-50.72	-13.00	Pass
5724.90	V	-43.86		
7633.20	V	-38.09		
3816.60	Horizontal	-49.51		
5724.90	H	-46.73		
7633.20	H	-38.49		
<p>Note:</p> <ol style="list-style-type: none"> The emission levels of below 1 GHz are 20 dB lower than the limit so not show in this report. For above 1 GHz, all test modes were performed, and just the worst case shown in the report. 				

LTE Band 2, WB: 20MHz				
RB size 1 & RB offset 0				
Frequency (MHz)	Spurious Emission		Limit (dBm)	Result
	Polarization	Level (dBm)		
Lowest Channel				
3720.00	Vertical	-50.83	-13.00	Pass
5580.00	V	-43.61		
7440.00	V	-38.56		
3720.00	Horizontal	-49.71		
5580.00	H	-41.35		
7440.00	H	-38.96		
Middle Channel				
3760.00	Vertical	-50.32	-13.00	Pass
5640.00	V	-43.83		
7520.00	V	-38.11		
3760.00	Horizontal	-49.74		
5640.00	H	-46.59		
7520.00	H	-38.96		
Highest Channel				
3800.00	Vertical	-50.89	-13.00	Pass
5700.00	V	-43.64		
7600.00	V	-38.18		
3800.00	Horizontal	-49.37		
5700.00	H	-46.59		
7600.00	H	-38.67		
<p><i>Note:</i></p> <ol style="list-style-type: none"> <i>The emission levels of below 1 GHz are 20 dB lower than the limit so not show in this report.</i> <i>For above 1 GHz, all test modes were performed, and just the worst case shown in the report.</i> 				

LTE Band 4 part:

LTE Band 4, WB: 1.4MHz				
RB size 1 & RB offset 0				
Frequency (MHz)	Spurious Emission		Limit (dBm)	Result
	Polarization	Level (dBm)		
Lowest Channel				
3421.40	Vertical	-36.58	-13.00	Pass
5132.10	V	-45.39		
6842.80	V	-38.52		
3421.40	Horizontal	-42.86		
5132.10	H	-45.19		
6842.80	H	-38.29		
Middle Channel				
3465.00	Vertical	-37.21	-13.00	Pass
5197.50	V	-45.64		
6930.00	V	-38.97		
3465.00	Horizontal	-42.86		
5197.50	H	-45.37		
6930.00	H	-38.62		
Highest Channel				
3508.60	Vertical	-36.89	-13.00	Pass
5262.90	V	-45.67		
7017.20	V	-38.91		
3508.60	Horizontal	-42.53		
5262.90	H	-45.24		
7017.20	H	-38.96		
<p><i>Note:</i></p> <ol style="list-style-type: none"> <i>The emission levels of below 1 GHz are 20 dB lower than the limit so not show in this report.</i> <i>For above 1 GHz, all test modes were performed, and just the worst case shown in the report.</i> 				

LTE Band 4, WB: 20MHz				
RB size 1 & RB offset 0				
Frequency (MHz)	Spurious Emission		Limit (dBm)	Result
	Polarization	Level (dBm)		
Lowest Channel				
3440.00	Vertical	-36.87	-13.00	Pass
5160.00	V	-45.62		
6880.00	V	-38.56		
3440.00	Horizontal	-42.91		
5160.00	H	-45.26		
6880.00	H	-38.37		
Middle Channel				
3465.00	Vertical	-37.69	-13.00	Pass
5197.50	V	-45.86		
6930.00	V	-38.64		
3465.00	Horizontal	-42.83		
5197.50	H	-45.47		
6930.00	H	-38.68		
Highest Channel				
3490.00	Vertical	-36.92	-13.00	Pass
5235.00	V	-45.86		
6980.00	V	-38.92		
3490.00	Horizontal	-42.56		
5235.00	H	-45.37		
6980.00	H	-38.95		
<i>Note:</i>				
1. The emission levels of below 1 GHz are 20 dB lower than the limit so not show in this report.				
2. For above 1 GHz, all test modes were performed, and just the worst case shown in the report.				

LTE Band 5 part:

LTE Band 5, WB: 1.4MHz				
RB size 1 & RB offset 0				
Frequency (MHz)	Spurious Emission		Limit (dBm)	Result
	Polarization	Level (dBm)		
Lowest Channel				
1649.40	Vertical	-51.68	-13.00	Pass
2474.10	V	-49.99		
3298.80	V	-50.06		
1649.40	Horizontal	-50.94		
2474.10	H	-52.18		
3298.80	H	-50.29		
Middle Channel				
1673.00	Vertical	-51.72	-13.00	Pass
2509.50	V	-49.36		
3346.00	V	-50.24		
1673.00	Horizontal	-50.16		
2509.50	H	-52.28		
3346.00	H	-50.36		
Highest Channel				
1696.60	Vertical	-51.69	-13.00	Pass
2544.90	V	-49.85		
3393.20	V	-50.11		
1696.60	Horizontal	-50.36		
2544.90	H	-52.24		
3393.20	H	-50.49		
<p><i>Note:</i></p> <ol style="list-style-type: none"> <i>The emission levels of below 1 GHz are 20 dB lower than the limit so not show in this report.</i> <i>For above 1 GHz, all test modes were performed, and just the worst case shown in the report.</i> 				

LTE Band 5, WB: 10MHz				
RB size 1 & RB offset 0				
Frequency (MHz)	Spurious Emission		Limit (dBm)	Result
	Polarization	Level (dBm)		
Lowest Channel				
1658.00	Vertical	-52.08	-13.00	Pass
2487.00	V	-50.26		
3316.00	V	-50.26		
1658.00	Horizontal	-50.98		
2487.00	H	-52.46		
3316.00	H	-50.37		
Middle Channel				
1673.00	Vertical	-51.89	-13.00	Pass
2509.50	V	-49.37		
3346.00	V	-50.36		
1673.00	Horizontal	-50.24		
2509.50	H	-52.37		
3346.00	H	-50.46		
Highest Channel				
1688.00	Vertical	-51.78	-13.00	Pass
2532.00	V	-50.24		
3376.00	V	-50.09		
1688.00	Horizontal	-50.47		
2532.00	H	-52.39		
3376.00	H	-50.87		
<p><i>Note:</i></p> <ol style="list-style-type: none"> <i>The emission levels of below 1 GHz are 20 dB lower than the limit so not show in this report.</i> <i>For above 1 GHz, all test modes were performed, and just the worst case shown in the report.</i> 				

LTE Band 12 part:

LTE Band 12, WB: 1.4MHz				
RB size 1 & RB offset 0				
Frequency (MHz)	Spurious Emission		Limit (dBm)	Result
	Polarization	Level (dBm)		
Lowest Channel				
1399.40	Vertical	-52.41	-13.00	Pass
2099.10	V	-47.65		
2798.80	V	-53.36		
1399.40	Horizontal	-51.65		
2099.10	H	-50.95		
2798.80	H	-53.28		
Middle Channel				
1415.00	Vertical	-52.47	-13.00	Pass
2122.50	V	-47.86		
2830.00	V	-53.38		
1415.00	Horizontal	-51.74		
2122.50	H	-50.98		
2830.00	H	-53.37		
Highest Channel				
1430.60	Vertical	-52.89	-13.00	Pass
2145.90	V	-47.84		
2861.20	V	-53.46		
1430.60	Horizontal	-51.79		
2145.90	H	-50.98		
2861.20	H	-53.36		
<p><i>Note:</i></p> <ol style="list-style-type: none"> <i>The emission levels of below 1 GHz are 20 dB lower than the limit so not show in this report.</i> <i>For above 1 GHz, all test modes were performed, and just the worst case shown in the report.</i> 				

LTE Band 12, WB: 10MHz				
RB size 1 & RB offset 0				
Frequency (MHz)	Spurious Emission		Limit (dBm)	Result
	Polarization	Level (dBm)		
Lowest Channel				
1408.00	Vertical	-52.49	-13.00	Pass
2112.00	V	-47.68		
2816.00	V	-53.39		
1408.00	Horizontal	-51.64		
2112.00	H	-50.87		
2816.00	H	-53.36		
Middle Channel				
1415.00	Vertical	-52.67	-13.00	Pass
2122.50	V	-47.89		
2830.00	V	-53.34		
1415.00	Horizontal	-51.86		
2122.50	H	-50.96		
2830.00	H	-53.34		
Highest Channel				
1422.00	Vertical	-52.98	-13.00	Pass
2133.00	V	-47.86		
2844.00	V	-53.39		
1422.00	Horizontal	-51.82		
2133.00	H	-50.93		
2844.00	H	-53.47		
<p><i>Note:</i></p> <ol style="list-style-type: none"> <i>The emission levels of below 1 GHz are 20 dB lower than the limit so not show in this report.</i> <i>For above 1 GHz, all test modes were performed, and just the worst case shown in the report.</i> 				

LTE Band 13 part:

LTE Band 13, WB: 5MHz				
RB size 1 & RB offset 0				
Frequency (MHz)	Spurious Emission		Limit (dBm)	Result
	Polarization	Level (dBm)		
Lowest Channel				
1559.00	Vertical	-60.60	-40.00	Pass
2338.50	V	-54.41	-13.00	
3118.00	V	-51.09		
1559.00	Horizontal	-60.52		
2338.50	H	-55.95		
3118.00	H	-50.86		
Middle Channel				
1564.00	Vertical	-60.38	-40.00	Pass
2346.00	V	-54.89	-13.00	
3128.00	V	-51.13		
1564.00	Horizontal	-60.47		
2346.00	H	-55.98		
3128.00	H	-50.92		
Highest Channel				
1569.00	Vertical	-60.49	-40.00	Pass
2353.50	V	-54.83	-13	
3138.00	V	-51.26		
1569.00	Horizontal	-60.39		
2353.50	H	-55.98		
3138.00	H	-50.89		
<p>Note:</p> <ol style="list-style-type: none"> The emission levels of below 1 GHz are 20 dB lower than the limit so not show in this report. For above 1 GHz, all test modes were performed, and just the worst case shown in the report. 				

LTE Band 13, WB: 10MHz				
RB size 1 & RB offset 0				
Frequency (MHz)	Spurious Emission		Limit (dBm)	Result
	Polarization	Level (dBm)		
Middle Channel				
1564.00	Vertical	-60.43	-13.00	Pass
2346.00	V	-54.91		
3128.00	V	-51.23		
1564.00	Horizontal	-60.38		
2346.00	H	-55.89		
3128.00	H	-50.97		
<p>Note:</p> <ol style="list-style-type: none"> The emission levels of below 1 GHz are 20 dB lower than the limit so not show in this report. For above 1 GHz, all test modes were performed, and just the worst case shown in the report. 				

LTE Band 17 part:

LTE Band 17, WB: 5MHz				
RB size 1 & RB offset 0				
Frequency (MHz)	Spurious Emission		Limit (dBm)	Result
	Polarization	Level (dBm)		
Lowest Channel				
1413.00	Vertical	-53.93	-13.00	Pass
2119.50	V	-53.52		
2826.00	V	-53.95		
1413.00	Horizontal	-54.51		
2119.50	H	-56.78		
2826.00	H	-53.54		
Middle Channel				
1420.00	Vertical	-53.89	-13.00	Pass
2130.00	V	-53.67		
2840.00	V	-53.86		
1420.00	Horizontal	-54.58		
2130.00	H	-56.36		
2840.00	H	-53.89		
Highest Channel				
1427.00	Vertical	-53.74	-13.00	Pass
2140.50	V	-53.69		
2854.00	V	-53.92		
1427.00	Horizontal	-54.97		
2140.50	H	-56.38		
2854.00	H	-53.98		
<p><i>Note:</i></p> <ol style="list-style-type: none"> <i>The emission levels of below 1 GHz are 20 dB lower than the limit so not show in this report.</i> <i>For above 1 GHz, all test modes were performed, and just the worst case shown in the report.</i> 				

LTE Band 17, WB: 10MHz				
RB size 1 & RB offset 0				
Frequency (MHz)	Spurious Emission		Limit (dBm)	Result
	Polarization	Level (dBm)		
Lowest Channel				
1418.00	Vertical	-53.44	-13.00	Pass
2127.00	V	-53.67		
2836.00	V	-53.92		
1418.00	Horizontal	-54.59		
2127.00	H	-56.98		
2836.00	H	-53.67		
Middle Channel				
1420.00	Vertical	-53.91	-13.00	Pass
2130.00	V	-53.46		
2840.00	V	-53.65		
1420.00	Horizontal	-54.89		
2130.00	H	-56.82		
2840.00	H	-53.92		
Highest Channel				
1422.00	Vertical	-53.49	-13.00	Pass
2133.00	V	-53.71		
2844.00	V	-53.94		
1422.00	Horizontal	-54.86		
2133.00	H	-56.83		
2844.00	H	-53.47		
<p><i>Note:</i></p> <ol style="list-style-type: none"> <i>The emission levels of below 1 GHz are 20 dB lower than the limit so not show in this report.</i> <i>For above 1 GHz, all test modes were performed, and just the worst case shown in the report.</i> 				

LTE Band 66 part:

LTE Band 66, WB: 1.4MHz				
RB size 1 & RB offset 0				
Frequency (MHz)	Spurious Emission		Limit (dBm)	Result
	Polarization	Level (dBm)		
Lowest Channel				
3421.40	Vertical	-44.47	-13.00	Pass
5132.10	V	-44.87		
6842.80	V	-38.72		
3421.40	Horizontal	-46.81		
5132.10	H	-43.85		
6842.80	H	-38.46		
Middle Channel				
3490.00	Vertical	-44.56	-13.00	Pass
5235.00	V	-44.91		
6980.00	V	-38.64		
3490.00	Horizontal	-46.89		
5235.00	H	-43.92		
6980.00	H	-38.76		
Highest Channel				
3558.60	Vertical	-44.68	-13.00	Pass
5337.90	V	-44.87		
7117.20	V	-38.76		
3558.60	Horizontal	-46.91		
5337.90	H	-43.86		
7117.20	H	-38.94		
<p><i>Note:</i></p> <ol style="list-style-type: none"> <i>The emission levels of below 1 GHz are 20 dB lower than the limit so not show in this report.</i> <i>For above 1 GHz, all test modes were performed, and just the worst case shown in the report.</i> 				

LTE Band 66, WB: 20MHz				
RB size 1 & RB offset 0				
Frequency (MHz)	Spurious Emission		Limit (dBm)	Result
	Polarization	Level (dBm)		
Lowest Channel				
3440.00	Vertical	-44.59	-13.00	Pass
5160.00	V	-44.95		
6880.00	V	-38.89		
3440.00	Horizontal	-46.82		
5160.00	H	-43.67		
6880.00	H	-38.59		
Middle Channel				
3490.00	Vertical	-44.58	-13.00	Pass
5235.00	V	-44.89		
6980.00	V	-38.69		
3490.00	Horizontal	-46.97		
5235.00	H	-43.86		
6980.00	H	-38.68		
Highest Channel				
3540.00	Vertical	-44.76	-13.00	Pass
5310.00	V	-44.89		
7080.00	V	-38.86		
3540.00	Horizontal	-46.73		
5310.00	H	-43.95		
7080.00	H	-38.67		
<p><i>Note:</i></p> <ol style="list-style-type: none"> <i>The emission levels of below 1 GHz are 20 dB lower than the limit so not show in this report.</i> <i>For above 1 GHz, all test modes were performed, and just the worst case shown in the report.</i> 				

LTE Band 71 part:

LTE Band 71, WB: 5MHz				
RB size 1 & RB offset 0				
Frequency (MHz)	Spurious Emission		Limit (dBm)	Result
	Polarization	Level (dBm)		
Lowest Channel				
1346.00	Vertical	-57.59	-13.00	Pass
2019.00	V	-57.15		
2692.00	V	-53.73		
1346.00	Horizontal	-58.98		
2019.00	H	-59.02		
2692.00	H	-52.96		
Middle Channel				
1361.00	Vertical	-57.64	-13.00	Pass
2041.50	V	-57.38		
2722.00	V	-53.86		
1361.00	Horizontal	-58.98		
2041.50	H	-59.06		
2722.00	H	-52.85		
Highest Channel				
1376.00	Vertical	-57.63	-13.00	Pass
2064.00	V	-57.89		
2752.00	V	-53.92		
1376.00	Horizontal	-58.96		
2064.00	H	-59.24		
2752.00	H	-52.79		
<p><i>Note:</i></p> <ol style="list-style-type: none"> <i>The emission levels of below 1 GHz are 20 dB lower than the limit so not show in this report.</i> <i>For above 1 GHz, all test modes were performed, and just the worst case shown in the report.</i> 				

LTE Band 71, WB: 20MHz				
RB size 1 & RB offset 0				
Frequency (MHz)	Spurious Emission		Limit (dBm)	Result
	Polarization	Level (dBm)		
Lowest Channel				
1331.00	Vertical	-57.68	-13.00	Pass
1996.50	V	-57.26		
2662.00	V	-53.89		
1331.00	Horizontal	-58.97		
1996.50	H	-59.26		
2662.00	H	-52.67		
Middle Channel				
1361.00	Vertical	-57.83	-13.00	Pass
2041.50	V	-57.64		
2722.00	V	-53.98		
1361.00	Horizontal	-58.87		
2041.50	H	-59.26		
2722.00	H	-52.68		
Highest Channel				
1391.00	Vertical	-57.89	-13.00	Pass
2086.50	V	-57.61		
2782.00	V	-53.47		
1391.00	Horizontal	-58.93		
2086.50	H	-59.67		
2782.00	H	-52.89		
<p><i>Note:</i></p> <ol style="list-style-type: none"> <i>The emission levels of below 1 GHz are 20 dB lower than the limit so not show in this report.</i> <i>For above 1 GHz, all test modes were performed, and just the worst case shown in the report.</i> 				

6.6 Frequency stability V.S. Temperature measurement

Test Requirement:	Part 22.355, Part 24.235, Part 27.54, Part 2.1055(a)(1)(b)
Test Method:	ANSI/TIA-603-D 2010
Limit:	±2.5ppm Within Authorized Band
Test setup:	
Test procedure:	<ol style="list-style-type: none"> 1. The equipment under test was connected to an external DC power supply and input rated voltage. 2. RF output was connected to a frequency counter or spectrum analyzer via feed through attenuators. 3. The EUT was placed inside the temperature chamber. 4. Set the spectrum analyzer RBW low enough to obtain the desired frequency resolution and measure EUT 25°C operating frequency as reference frequency. 5. Turn EUT off and set the chamber temperature to -30°C. After the temperature stabilized for approximately 30 minutes recorded the frequency. 6. Repeat step measure with 10°C increased per stage until the highest temperature of +50°C reached
Test Instruments:	Refer to section 5.9 for details
Test mode:	Refer to section 5.3 for details
Test results:	Refer to FCC ID: ZMONL668AM00, Report No.: FG8O1914-01B.

6.7 Frequency stability V.S. Voltage measurement

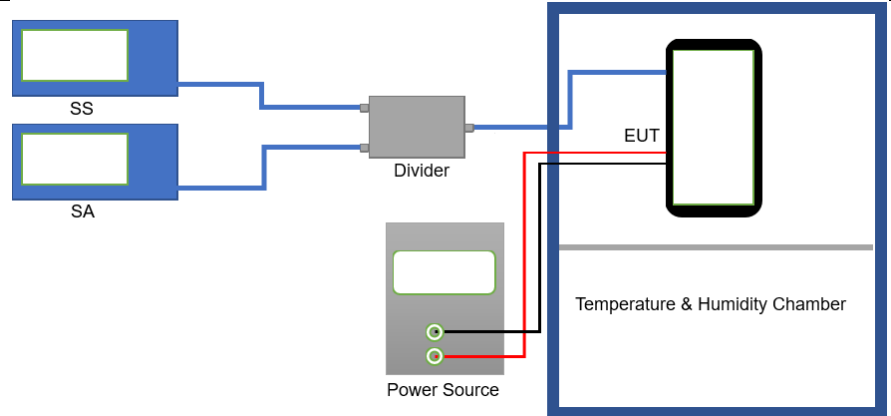
Test Requirement:	Part 22.355, Part 24.235, Part 27.54, Part 2.1055(d)(2)
Test Method:	ANSI/TIA-603-D 2010
Limit:	±2.5ppm Within Authorized Band
Test setup:	
Test procedure:	<ol style="list-style-type: none"> 1. Set chamber temperature to 25°C. Use a variable DC power source to power the EUT and set the voltage to rated voltage. 2. Set the spectrum analyzer RBW low enough to obtain the desired frequency resolution and recorded the frequency. 3. Reduce the input voltage to specify extreme voltage variation (+/- 15%) and endpoint, record the maximum frequency change.
Test Instruments:	Refer to section 5.9 for details
Test mode:	Refer to section 5.3 for details
Test results:	Refer to FCC ID: ZMONL668AM00, Report No.: FG8O1914-01B.

7 Test Setup Photo

Radiated Spurious Emission
Below 1GHz

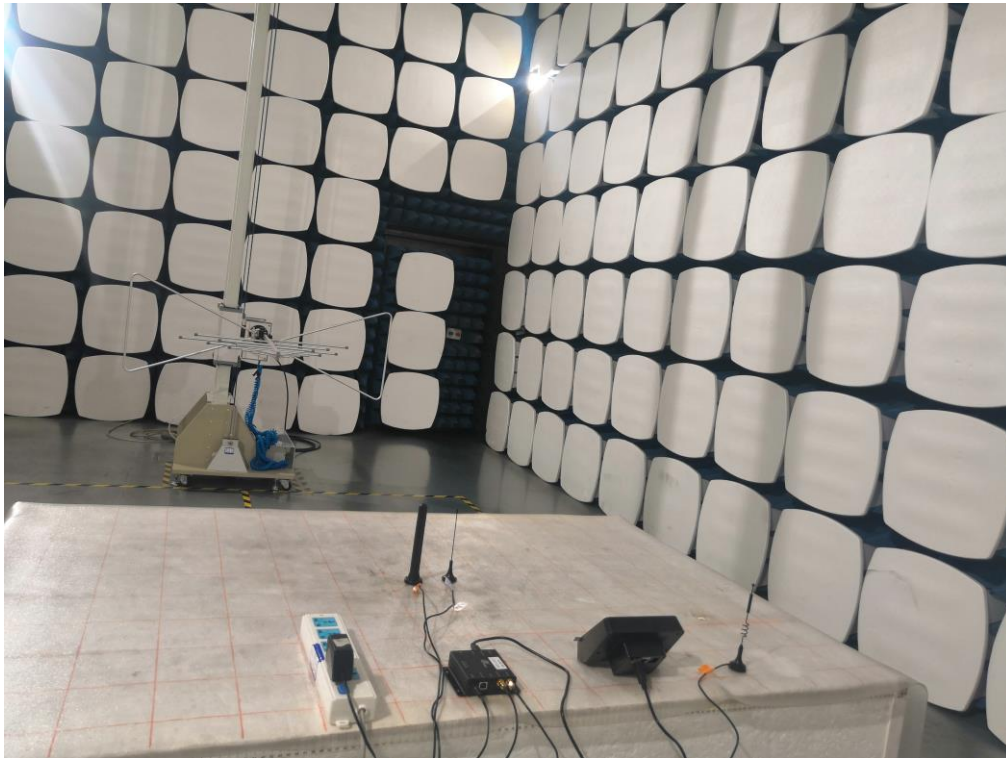

Above 1GHz

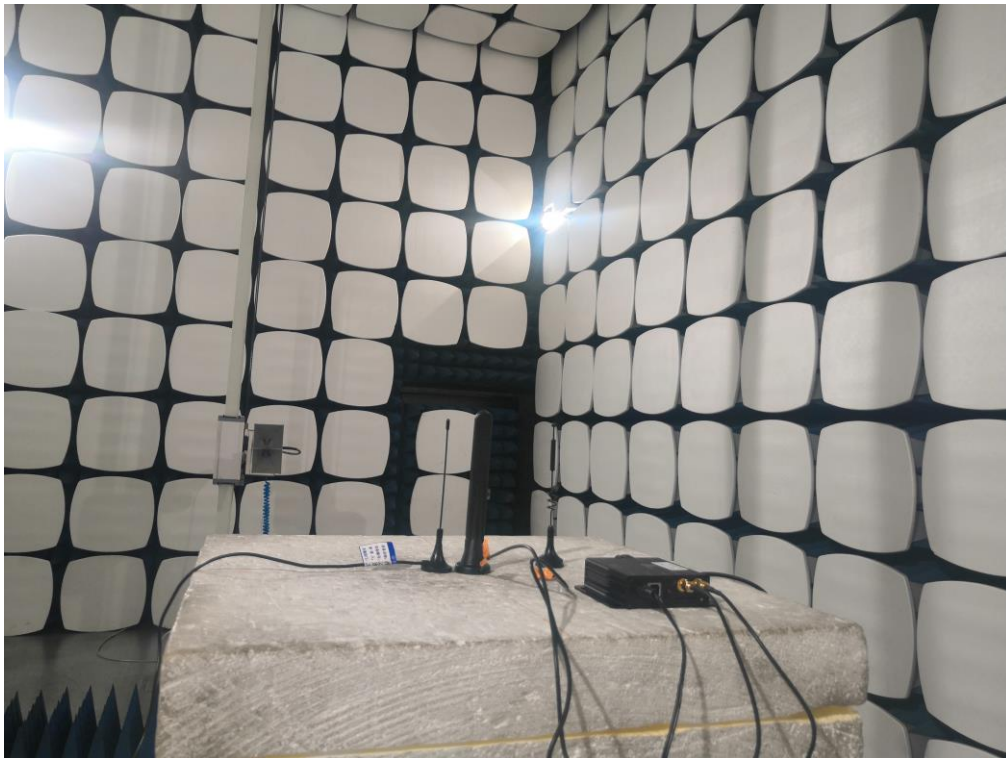

8 EUT Constructional Details

Reference to the test report No. CCISE190808701.

-----End of report-----