

FCC TEST REPORT

(PART 22)



Applicant:	PAX Technology Limited
Address:	Room 2416, 24/F., Sun Hung Kai Centre, 30 Harbour Hong Kong China

Manufacturer or Supplier:	PAX Computer Technology (Shenzhen) Co., Ltd.
Address:	401 and 402, Building 3, Shenzhen Software Park, Nanshan District, Shenzhen City, Guangdong Province, P.R.C.
Product:	Smart Mobile Payment Terminal
Brand Name:	PAX
Model Name:	A920
FCC ID:	V5PA920MG
Date of tests:	Jan. 06, 2022 ~ Mar. 04, 2022

The tests have been carried out according to the requirements of the following standard:

- FCC PART 22, Subpart H** **FCC Part 2**
 ANSI/TIA/EIA-603-D **ANSI C63.26-2015**
 ANSI/TIA/EIA-603-E

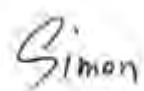
CONCLUSION: The submitted sample was found to COMPLY with the test requirement

Prepared by Simon Wang Engineer / Mobile Department	Approved by Luke Lu Manager / Mobile Department
 Date: Mar. 04, 2022	 Date: Mar. 04, 2022

This report is governed by, and incorporates by reference, CPS Conditions of Service as posted at the date of issuance of this report at <http://www.bureauveritas.com/home/about-us/our-business/cps/about-us/terms-conditions> and is intended for your exclusive use. Any copying or replication of this report to or for any other person or entity, or use of our name or trademark, is permitted only with our prior written permission. This report sets forth our findings solely with respect to the test samples identified herein. The results set forth in this report are not indicative or representative of the quality or characteristics of the lot from which a test sample was taken or any similar or identical product unless specifically and expressly noted. Our report includes all of the tests requested by you and the results thereof based upon the information that you provided to us. Measurement uncertainty is only provided upon request for accredited tests. You have 60 days from date of issuance of this report to notify us of any material error or omission caused by our negligence or if you require measurement uncertainty; provided, however, that such notice shall be in writing and shall specifically address the issue you wish to raise. A failure to raise such issue within the prescribed time shall constitute your unqualified acceptance of the completeness of this report, the tests conducted and the correctness of the report contents.



TABLE OF CONTENTS

RELEASE CONTROL RECORD4

1 SUMMARY OF TEST RESULTS.....5

* REFER TO KDB 971168 D01 POWER MEAS LICENSE DIGITAL SYSTEMS V03R01.....5

1.1 MEASUREMENT UNCERTAINTY6

1.2 TEST SITE AND INSTRUMENTS6

2 GENERAL INFORMATION8

2.1 GENERAL DESCRIPTION OF EUT8

2.2 CONFIGURATION OF SYSTEM UNDER TEST 10

2.3 DESCRIPTION OF SUPPORT UNITS 11

2.4 TEST ITEM AND TEST CONFIGURATION..... 11

2.5 EUT OPERATING CONDITIONS 15

2.6 GENERAL DESCRIPTION OF APPLIED STANDARDS 16

3 TEST TYPES AND RESULTS.....17

3.1 OUTPUT POWER MEASUREMENT 17

3.1.1 LIMITS OF OUTPUT POWER MEASUREMENT 17

3.1.2 TEST PROCEDURES 17

3.1.3 TEST SETUP 18

3.1.4 TEST RESULTS 18

3.2 FREQUENCY STABILITY MEASUREMENT 24

3.2.1 LIMITS OF FREQUENCY STABILITY MEASUREMENT 24

3.2.2 TEST PROCEDURE 24

3.2.3 TEST SETUP 24

3.2.4 TEST RESULTS 25

3.3 OCCUPIED BANDWIDTH MEASUREMENT 26

3.3.1 TEST PROCEDURES 26

3.3.2 TEST SETUP 26

3.3.3 TEST RESULTS 27

3.4 BAND EDGE MEASUREMENT 28

3.4.1 LIMITS OF BAND EDGE MEASUREMENT 28

3.4.2 TEST SETUP 28

3.4.3 TEST PROCEDURES 29

3.4.4 TEST RESULTS 30

3.5 CONDUCTED SPURIOUS EMISSIONS..... 31

3.5.1 LIMITS OF CONDUCTED SPURIOUS EMISSIONS MEASUREMENT 31

3.5.2 TEST PROCEDURE 31

3.5.3 TEST SETUP 31

3.5.4 TEST RESULTS 32

3.6 RADIATED EMISSION MEASUREMENT 33

3.6.1 LIMITS OF RADIATED EMISSION MEASUREMENT 33

3.6.2 TEST PROCEDURES 33



**BUREAU
VERITAS**

Test Report No.: W7L-P22010007RF02

3.6.3	DEVIATION FROM TEST STANDARD	33
3.6.4	TEST SETUP	34
3.6.5	TEST RESULTS	35
3.7	PEAK TO AVERAGE RATIO	55
3.7.1	LIMITS OF PEAK TO AVERAGE RATIO MEASUREMENT	55
3.7.2	TEST SETUP	55
3.7.3	TEST PROCEDURES	55
3.7.4	TEST RESULTS	56
4	PHOTOGRAPHS OF THE TEST CONFIGURATION	57
5	INFORMATION ON THE TESTING LABORATORIES	58
6	MODIFICATIONS RECORDERS FOR ENGINEERING CHANGES TO THE EUT BY THE LAB	59
7	APPENDIX	60
	WCDMA BAND5	60
	PEAK-TO-AVERAGE RATIO	60
	TEST RESULT	60
	TEST GRAPHS	61
	26DB BANDWIDTH AND OCCUPIED BANDWIDTH	62
	TEST RESULT	62
	TEST GRAPHS	62
	BAND EDGE	64
	TEST RESULT	64
	TEST GRAPHS	64
	CONDUCTED SPURIOUS EMISSION	65
	TEST RESULT	65
	TEST GRAPHS	65
	FREQUENCY STABILITY	68
	TEST RESULT	68
	LTE BAND5	69
	PEAK-TO-AVERAGE RATIO(CCDF)	69
	TEST RESULT	69
	TEST GRAPHS	71
	26DB BANDWIDTH AND OCCUPIED BANDWIDTH	88
	TEST RESULT	88
	TEST GRAPHS	89
	BAND EDGE	98
	TEST RESULT	98
	TEST GRAPHS	98
	CONDUCTED SPURIOUS EMISSION	110
	TEST RESULT	110
	TEST GRAPHS	111
	FREQUENCY STABILITY	128
	TEST RESULT	128



BUREAU
VERITAS

Test Report No.: W7L-P22010007RF02

RELEASE CONTROL RECORD

ISSUE NO.	REASON FOR CHANGE	DATE ISSUED
W7L-P22010007RF02	Original release	Mar. 04, 2022



1 SUMMARY OF TEST RESULTS

The EUT has been tested according to the following specifications:

APPLIED STANDARD: FCC Part 22 & Part 2		
STANDARD SECTION	TEST TYPE	RESULT
§2.1046	Conducted Output Power	Compliance
§22.913 (a)(5)	Effective Radiated Power	Compliance
§2.1055 §22.355	Frequency Stability	Compliance
§2.1049	Occupied Bandwidth	Compliance
§22.913 (d)	Peak to average ratio*	Compliance
§22.917(a)	Band Edge Measurements	Compliance
§2.1051 §22.917(a)	Conducted Spurious Emissions	Compliance
§2.1053 §22.917(a)	Radiated Spurious Emissions	Compliance

* Refer to KDB 971168 D01 Power Meas License Digital Systems v03r01.

1.1 MEASUREMENT UNCERTAINTY

Where relevant, the following measurement uncertainty levels have been estimated for tests performed on the EUT as specified in CISPR 16-4-2:

MEASUREMENT	UNCERTAINTY
Maximum Peak Output Power	±2.06dB
Frequency Stability	±76.97Hz
Radiated emissions (30MHz~1GMHz)	±4.98dB
Radiated emissions (1GMHz ~6GMHz)	±4.70dB
Radiated emissions (6GMHz ~18GMHz)	±4.60dB
Radiated emissions (18GMHz ~40GMHz)	±4.12dB
Conducted emissions	±4.01dB
Occupied Channel Bandwidth	±43.58KHz
Band Edge Measurements	±4.70dB
Peak to average ratio	±0.76dB

This uncertainty represents an expanded uncertainty expressed at approximately the 95% confidence level using a coverage factor of k=2.

1.2 TEST SITE AND INSTRUMENTS

Equipment	Manufacturer	Model No.	Serial No.	Last Cal.	Next Cal.
MXE EMI Receiver	KEYSIGHT	N9038A-544	MY54450026	Apr. 22,21	Apr. 21,22
EXA Signal Analyzer	KEYSIGHT	N9010A-544	MY54510355	Jun. 03,21	Jun. 02,22
Bilog Antenna	ETS-LINDGREN	3143B	00161965	Mar. 05,21	Mar. 04,22
Horn Antenna	ETS-LINDGREN	3117	00168728	Apr. 02,21	Apr. 01,22
Horn Antenna (18GHz-40GHz)	N/A	QWH-SL-18-40-K-SG/QMS-00361	15433	Aug. 25, 21	Aug. 24, 22
Radio Communication Analyzer	ANRITSU	MT8820C	6201465426	Feb. 25,21	Feb. 24,22
Radio Communication Analyzer	ANRITSU	MT8820C	6201465426	Feb. 24,22	Feb. 23,23
Signal Pre-Amplifier	EMSI	EMC 9135	980249	Jun. 02,21	Jun. 01,22
Signal Pre-Amplifier	EMSI	EMC 012645B	980257	Jun. 03,21	Jun. 02,22
Signal Pre-Amplifier	EMSI	EMC 184045B	980259	Apr. 22,21	Apr. 21,22
3m Semi-anechoic Chamber	ETS-LINDGREN	9m*6m*6m	Euroshieldpn-CT0001143-1216	May. 19,20	May. 18,23
Test Software	E3	V 9.160323	N/A	N/A	N/A
Test Software	ADT	ADT_Radiated_V 7.6.15.9.2	N/A	N/A	N/A
10dB Attenuator	JFW/USA	50HF-010-SMA	1505	Jun. 03,21	Jun. 02,22



**BUREAU
VERITAS**

Test Report No.: W7L-P22010007RF02

Power Meter	Anritsu	ML2495A	1506002	Apr. 07,21	Apr. 06,22
Power Sensor	Anritsu	MA2411B	1339352	May. 07,21	May. 06,22
Temperature Chamber	ESPEC	SH-242	93000855	Jun. 02,21	Jun. 01,22
MXG Analog Microvave Signal Generator	KEYSIGHT	N5183A	MY50143024	Mar. 05,21	Mar. 04,22
Power Divider	MCLI/USA	PS2-15	24880	N/A	N/A

- NOTE:**
1. The calibration interval of the above test instruments is 12 months or 36 months and the calibrations are traceable to CEPREI/CHINA, GRGT/CHINA and NIM/CHINA.
 2. The test was performed in 3m Semi-anechoic Chamber and RF Oven Room.
 3. The horn antenna is used only for the measurement of emission frequency above 1GHz if tested.
 4. The FCC Site Registration No. is 525120; The Designation No. is CN1171.



2 GENERAL INFORMATION

2.1 GENERAL DESCRIPTION OF EUT

PRODUCT	Smart Mobile Payment Terminal	
BRAND NAME	PAX	
MODEL NAME	A920	
NOMINAL VOLTAGE	5Vdc (adapter) 3.7Vdc (Li-ion, battery)	
MODULATION TYPE	WCDMA	BPSK,QPSK
	LTE	QPSK, 16QAM
FREQUENCY RANGE	WCDMA	826.4MHz ~ 846.6MHz
	LTE Band 5 (Channel Bandwidth: 1.4MHz)	824.7MHz ~ 848.3MHz
	LTE Band 5 (Channel Bandwidth: 3MHz)	825.5MHz ~ 847.5MHz
	LTE Band 5 (Channel Bandwidth: 5MHz)	826.5MHz ~ 846.5MHz
	LTE Band 5 (Channel Bandwidth: 10MHz)	829MHz ~ 844MHz
MAX. ERP POWER	WCDMA	152.41mW
	LTE Band 5 (Channel Bandwidth: 1.4MHz)	156.31mW
	LTE Band 5 (Channel Bandwidth: 3MHz)	155.60mW
	LTE Band 5 (Channel Bandwidth: 5MHz)	155.96mW
	LTE Band 5 (Channel Bandwidth: 10MHz)	157.76mW
EMISSION DESIGNATOR GOGN	WCDMA	4M16F9W
	LTE Band 5 (Channel Bandwidth: 1.4MHz)	QPSK: 1M10G7D
		16QAM: 1M10W7D
	LTE Band 5 (Channel Bandwidth: 3MHz)	QPSK: 2M70G7D
		16QAM: 2M70W7D
	LTE Band 5 (Channel Bandwidth: 5MHz)	QPSK: 4M51G7D
16QAM: 4M51W7D		
LTE Band 5 (Channel Bandwidth: 10MHz)	QPSK: 8M99G7D 16QAM: 8M99W7D	
ANTENNA TYPE	PIFA Antenna with 1dBi gain for WCDMA5/LTE band 5	
I/O PORTS	Refer to user's manual	
CABLE SUPPLIED	USB cable: unshielded without ferrite, 1.0meter	



EXTREME TEMPERATURE	-10-50 °C
EXTREME VOLTAGE	3.1V- 4.2V

NOTE:

1. For a more detailed features description, please refer to the manufacturer's specifications or the user's manual.
2. The EUT incorporates a SISO function. Physically, the EUT provides one completed transmitter and one receiver.

MODULATION MODE	TX FUNCTION
WCDMA	1TX/1RX
LTE	1TX/1RX

3. For the test results, the EUT had been tested with all conditions. But only the worst case was shown in test report.

List of Accessory:

ACCESSORIES	BRAND	MODEL	SPECIFICATION
Battery	/	IS900	Capacity : 3.7vdc 5250mAh
AC Adapter	/	GLH50D2000HW	I/P:100-240Vac, 0.4A O/P: 5Vdc, 2A
USB Cable	/	/	Signal Line, 1.0meter



2.2 CONFIGURATION OF SYSTEM UNDER TEST FOR RADIATION EMISSION

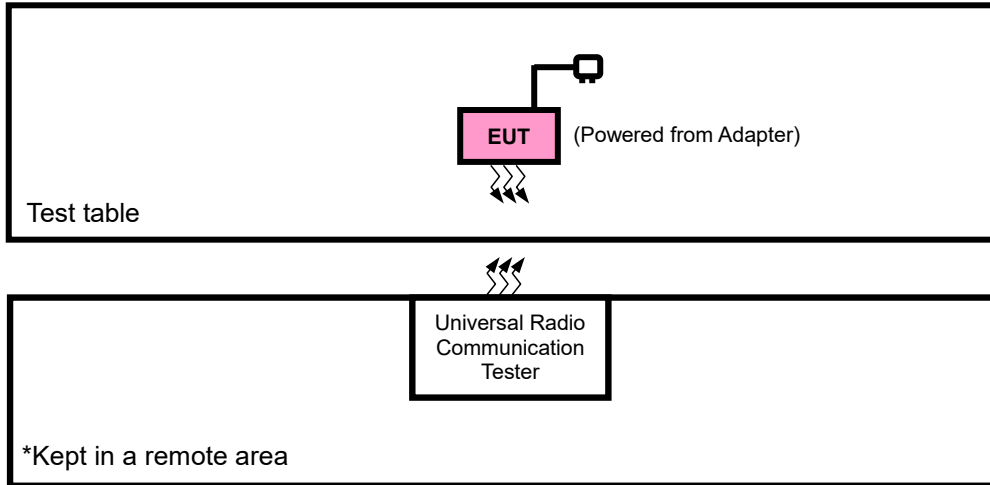



2.3 DESCRIPTION OF SUPPORT UNITS

The EUT has been tested as an independent unit together with other necessary accessories or support units. The following support units or accessories were used to form a representative test configuration during the tests.

NO.	PRODUCT	BRAND	MODEL NO.	SERIAL NO.	FCC ID
1	DC source	Kikusui/JP	PMX18-5A	0000001	N/A

NO.	SIGNAL CABLE DESCRIPTION OF THE ABOVE SUPPORT UNITS
1	DC Line: Unshielded, Detachable 1.0m

2.4 TEST ITEM AND TEST CONFIGURATION

Pre-Scan has been conducted to determine the worst-case mode from all possible combinations between available modulations, data rates, XYZ axis and antenna ports. The worst case in ERP and radiated emission was found when positioned on X-plane for GPRS/EDGE /LTE. Following channel(s) was (were) selected for the final test as listed below:

EUT CONFIGURE MODE	DESCRIPTION
A	EUT + Adapter with WCDMA or LTE link
B	EUT + Battery with WCDMA or LTE link



**BUREAU
VERITAS**

Test Report No.: W7L-P22010007RF02

WCDMA MODE

EUT CONFIGURE MODE	TEST ITEM	AVAILABLE CHANNEL	TESTED CHANNEL	MODE
A	ERP	4132 to 4233	4132, 4182, 4233	WCDMA
B	FREQUENCY STABILITY	4132 to 4233	4132, 4233	WCDMA
A	OCCUPIED BANDWIDTH	4132 to 4233	4132, 4182, 4233	WCDMA
A	BAND EDGE	4132 to 4233	4132, 4182, 4233	WCDMA
A	CONDCUDED EMISSION	4132 to 4233	4132, 4233	WCDMA
A	RADIATED EMISSION	4132 to 4233	4132, 4182, 4233	WCDMA
A	PEAK TO AVERAGE RATIO	4132 to 4233	4132, 4182, 4233	WCDMA



**BUREAU
VERITAS**

Test Report No.: W7L-P22010007RF02

LTE BAND 5 MODE

TEST ITEM	Available Channel	Tested Channel	Channel bandwidth	modulation	mode
ERP	20407 to 20643	20407, 20525, 20643	1.4MHz	QPSK,16QAM	1 RB / 0 RB Offset
	20415 to 20635	20415, 20525, 20635	3MHz	QPSK,16QAM	1 RB / 0 RB Offset
	20425 to 20625	20425, 20525, 20625	5MHz	QPSK,16QAM	1 RB / 0 RB Offset
	20450 to 20600	20450, 20525, 20600	10MHz	QPSK,16QAM	1 RB / 0 RB Offset
FREQUENCY STABILITY	20407 to 20643	20407, 20643	1.4MHz	QPSK	1 RB / 0 RB Offset
	20415 to 20635	20415, 20635	3MHz	QPSK	1 RB / 0 RB Offset
	20425 to 20625	20425, 20625	5MHz	QPSK	1 RB / 0 RB Offset
	20450 to 20600	20450, 20600	10MHz	QPSK	1 RB / 0 RB Offset
OCCUPIED BANDWIDTH	20407 to 20643	20407, 20525, 20643	1.4MHz	QPSK,16QAM	6 RB / 0 RB Offset
	20415 to 20635	20415, 20525, 20635	3MHz	QPSK,16QAM	15 RB / 0 RB Offset
	20425 to 20625	20425, 20525, 20625	5MHz	QPSK,16QAM	25 RB / 0 RB Offset
	20450 to 20600	20450, 20525, 20600	10MHz	QPSK,16QAM	50 RB / 0 RB Offset
BAND EDGE	20407 to 20643	20407	1.4 MHz	QPSK,16QAM	1 RB / 0 RB Offset
					6 RB / 0 RB Offset
	20407 to 20643	20643	1.4 MHz	QPSK,16QAM	1 RB / 5 RB Offset
					6 RB / 0 RB Offset
	20415 to 20635	20415	3 MHz	QPSK,16QAM	1 RB / 0 RB Offset
					15 RB / 0 RB Offset
	20415 to 20635	20635	3 MHz	QPSK,16QAM	1 RB / 14 RB Offset
					15 RB / 0 RB Offset
	20425 to 20625	20425	5MHz	QPSK,16QAM	1 RB / 0 RB Offset
					25 RB / 0 RB Offset
	20425 to 20625	20625	5MHz	QPSK,16QAM	1 RB / 24 RB Offset
					25 RB / 0 RB Offset
20450 to 20600	20450	10MHz	QPSK,16QAM	1 RB / 0 RB Offset	
				50 RB / 0 RB Offset	
20450 to 20600	20600	10MHz	QPSK,16QAM	1 RB / 49 RB Offset	
				50 RB / 0 RB Offset	



**BUREAU
VERITAS**

Test Report No.: W7L-P22010007RF02

CONDCUDED EMISSION	20407 to 20643	20407, 20525, 20643	1.4MHz	QPSK	1 RB / 0 RB Offset
	20415 to 20635	20415, 20525, 20635	3MHz	QPSK	1 RB / 0 RB Offset
	20425 to 20625	20425, 20525, 20625	5MHz	QPSK	1 RB / 0 RB Offset
	20450 to 20600	20450, 20525, 20600	10MHz	QPSK	1 RB / 0 RB Offset
RADIATED EMISSION	20407 to 20643	20525	1.4MHz	QPSK	1 RB / 0 RB Offset
	20415 to 20635	20415, 20525, 20635	3MHz	QPSK	1 RB / 0 RB Offset
	20425 to 20625	20525	5MHz	QPSK	1 RB / 0 RB Offset
	20450 to 20600	20525	10MHz	QPSK	1 RB / 0 RB Offset
PEAK TO AVERAGE RATIO	20407 to 20643	20407, 20525, 20643	1.4MHz	QPSK,16QAM	1 RB / 0 RB Offset
	20415 to 20635	20415, 20525, 20635	3MHz	QPSK,16QAM	1 RB / 0 RB Offset
	20425 to 20625	20425, 20525, 20625	5MHz	QPSK,16QAM	1 RB / 0 RB Offset
	20450 to 20600	20450, 20525, 20600	10MHz	QPSK,16QAM	1 RB / 0 RB Offset



TEST CONDITION:

TEST ITEM	ENVIRONMENTAL CONDITIONS	INPUT POWER	TESTED BY
EIRP	23deg. C, 70%RH	5V By Adapter	Jace Hu
FREQUENCY STABILITY	23deg. C, 70%RH	5V By Battery	James Fu
OCCUPIED BANDWIDTH	23deg. C, 70%RH	5V By Adapter	James Fu
BAND EDGE	23deg. C, 70%RH	5V By Adapter	James Fu
CONDUCTED EMISSION	23deg. C, 70%RH	5V By Adapter	James Fu
RADIATED EMISSION	23deg. C, 70%RH	5V By Adapter	James Fu
PEAK TO AVERAGE RATIO	23deg. C, 70%RH	5V By Adapter	Jace Hu

2.5 EUT OPERATING CONDITIONS

The EUT makes a call to the communication simulator. The communication simulator station system controlled a EUT to export maximum output power under transmission mode and specific channel frequency



Test Report No.: W7L-P22010007RF02

2.6 GENERAL DESCRIPTION OF APPLIED STANDARDS

The EUT is a RF product. According to the specifications of the manufacturer, it must comply with the requirements of the following standards:

FCC 47 CFR Part 2

FCC 47 CFR Part 22

KDB 971168 D01 Power Meas License Digital Systems v03r01

ANSI/TIA/EIA-603-D

ANSI/TIA/EIA-603-E

ANSI C63.26-2015

NOTE: All test items have been performed and recorded as per the above standards.



3 TEST TYPES AND RESULTS

3.1 OUTPUT POWER MEASUREMENT

3.1.1 LIMITS OF OUTPUT POWER MEASUREMENT

Mobile / Portable station are limited to 7 watts e.r.p.

3.1.2 TEST PROCEDURES

EIRP / ERP MEASUREMENT:

Per KDB 971168 D01 Power Meas License Digital Systems v03r01 or subclause 5.2.5.5 of ANSI C63.26-2015, the relevant equation for determining the ERP or EIRP from the conducted RF output power measured using the guidance provided above is:

$$\text{ERP or EIRP} = P_{\text{Meas}} + G_{\text{T}} - L_{\text{C}}$$

Where:

ERP or EIRP = effective radiated power or equivalent isotropically radiated power, respectively

(expressed in the same units as P_{Meas} , typically dBW or dBm);

P_{Meas} = measured transmitter output power or PSD, in dBm or dBW;

G_{T} = gain of the transmitting antenna, in dBd (ERP) or dBi (EIRP);

L_{C} = signal attenuation in the connecting cable between the transmitter and antenna, in dB.

CONDUCTED POWER MEASUREMENT:

The EUT was set up for the maximum power with WCDMA link data modulation and link up with simulator. Set the EUT to transmit under low, middle and high channel and record the power level shown on simulator.



3.1.3 TEST SETUP

EIRP / ERP Measurement:

CONDUCTED POWER MEASUREMENT:

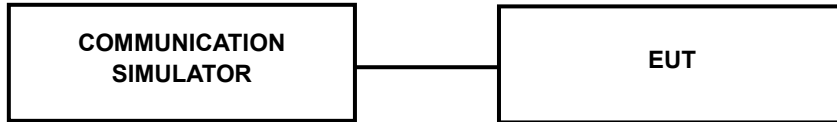

3.1.4 TEST RESULTS

CONDUCTED OUTPUT POWER (dBm)

Band	WCDMA V			Max. Tune-up Power
	4132	4182	4233	
Channel	826.4	836.4	846.6	
Frequency	826.4	836.4	846.6	
RMC 12.2K	22.84	22.98	22.89	23.5
HSDPA Subtest-1	21.82	21.95	21.87	22.5
HSDPA Subtest-2	21.83	21.96	21.86	22.5
HSDPA Subtest-3	21.35	21.48	21.37	22.0
HSDPA Subtest-4	21.32	21.46	21.35	22.0
HSUPA Subtest-1	21.81	21.97	21.85	22.5
HSUPA Subtest-2	19.86	19.99	19.88	20.5
HSUPA Subtest-3	20.85	20.96	20.87	21.5
HSUPA Subtest-4	19.84	19.96	19.86	20.5
HSUPA Subtest-5	21.81	21.95	21.85	22.5



**BUREAU
VERITAS**

Test Report No.: W7L-P22010007RF02

LTE Band 5

Band/BW	Modulation	RB Size	RB Offset	Low CH 20407	Mid CH 20525	High CH 20643	MPR
				Frequency 824.7 MHz	Frequency 836.5 MHz	Frequency 848.3 MHz	
5/ 1.4	QPSK	1	0	22.85	22.92	23.08	0
		1	2	22.68	22.68	22.89	0
		1	5	22.68	22.66	22.85	0
		3	0	22.85	22.86	23.09	0
		3	1	22.74	22.76	22.87	0
		3	3	22.66	22.66	22.85	0
		6	0	21.77	21.75	21.96	1
	16QAM	1	0	21.39	21.40	21.59	1
		1	2	21.00	20.97	21.20	1
		1	5	21.03	21.03	21.27	1
		3	0	21.73	21.75	21.92	1
		3	1	21.72	21.82	21.95	1
		3	3	21.83	21.85	22.06	1
		6	0	20.78	20.85	20.99	2

Band/BW	Modulation	RB Size	RB Offset	Low CH 20415	Mid CH 20525	High CH 20635	MPR
				Frequency 825.5 MHz	Frequency 836.5 MHz	Frequency 847.5 MHz	
5/ 3	QPSK	1	0	22.87	22.94	23.07	0
		1	7	22.64	22.69	22.89	0
		1	14	22.64	22.66	22.85	0
		8	0	21.84	21.89	22.09	1
		8	3	21.67	21.76	21.89	1
		8	7	21.63	21.73	21.89	1
		15	0	21.74	21.76	21.90	1
	16QAM	1	0	21.36	21.46	21.62	1
		1	7	20.97	21.00	21.18	1
		1	14	21.06	21.03	21.27	1
		8	0	20.69	20.76	20.92	2
		8	3	20.77	20.77	20.98	2
		8	7	20.85	20.83	21.02	2
		15	0	20.78	20.79	21.02	2



BUREAU
VERITAS

Test Report No.: W7L-P22010007RF02

Band/BW	Modulation	RB Size	RB Offset	Low CH 20425	Mid CH 20525	High CH 20625	MPR
				Frequency 826.5 MHz	Frequency 836.5 MHz	Frequency 846.5 MHz	
5/ 5	QPSK	1	0	22.88	22.89	23.08	0
		1	12	22.69	22.66	22.89	0
		1	24	22.65	22.65	22.89	0
		12	0	21.87	21.89	22.06	1
		12	6	21.67	21.77	21.90	1
		12	13	21.67	21.69	21.90	1
		25	0	21.72	21.79	21.93	1
	16QAM	1	0	21.37	21.42	21.62	1
		1	12	20.94	21.03	21.17	1
		1	24	21.06	21.03	21.26	1
		12	0	20.69	20.74	20.89	2
		12	6	20.74	20.81	20.94	2
		12	13	20.80	20.85	21.05	2
		25	0	20.78	20.80	20.99	2

Band/BW	Modulation	RB Size	RB Offset	Low CH 20450	Mid CH 20525	High CH 20600	MPR
				Frequency 829 MHz	Frequency 836.5 MHz	Frequency 844 MHz	
5/ 10	QPSK	1	0	22.93	22.96	23.13	0
		1	24	22.71	22.74	22.91	0
		1	49	22.70	22.73	22.90	0
		25	0	21.91	21.94	22.11	1
		25	12	21.75	21.78	21.95	1
		25	25	21.71	21.74	21.91	1
		50	0	21.78	21.81	21.98	1
	16QAM	1	0	21.44	21.47	21.64	1
		1	24	21.02	21.05	21.22	1
		1	49	21.08	21.11	21.28	1
		25	0	20.77	20.80	20.97	2
		25	12	20.80	20.83	21.00	2
		25	25	20.87	20.90	21.07	2
		50	0	20.84	20.87	21.04	2



**BUREAU
VERITAS**

Test Report No.: W7L-P22010007RF02

ERP POWER (dBm)

WCDMA

Channel	Frequency (MHz)	Conducted Power (dBm)	G _T -L _c (dB)	ERP (dBm)	ERP (mW)	Limit (W)
4132	826.4	22.84	1	21.69	147.57	7
4182	836.4	22.98	1	21.83	152.41	7
4233	846.6	22.89	1	21.74	149.28	7

REMARKS: ERP Output Power (dBm) = EIRP (dBm) -2.15(dB).



LTE BAND 5

CHANNEL BANDWIDTH: 1.4MHz QPSK

Channel	Frequency (MHz)	Conducted Power (dBm)	G _T -L _C (dB)	ERP (dBm)	ERP (mW)	Limit (W)
20407	824.7	22.85	1	21.7	147.91	7
20525	836.5	22.92	1	21.77	150.31	7
20643	848.3	23.09	1	21.94	156.31	7

CHANNEL BANDWIDTH: 1.4MHz 16QAM

Channel	Frequency (MHz)	Conducted Power (dBm)	G _T -L _C (dB)	ERP (dBm)	ERP (mW)	Limit (W)
20407	824.7	21.83	1	20.68	116.95	7
20525	836.5	21.85	1	20.7	117.49	7
20643	848.3	22.06	1	20.91	123.31	7

CHANNEL BANDWIDTH: 3MHz QPSK

Channel	Frequency (MHz)	Conducted Power (dBm)	G _T -L _C (dB)	ERP (dBm)	ERP (mW)	Limit (W)
20415	825.5	22.87	1	21.72	148.59	7
20525	836.5	22.94	1	21.79	151.01	7
20635	847.5	23.07	1	21.92	155.6	7

CHANNEL BANDWIDTH: 3MHz 16QAM

Channel	Frequency (MHz)	Conducted Power (dBm)	G _T -L _C (dB)	ERP (dBm)	ERP (mW)	Limit (W)
20415	825.5	21.36	1	20.21	104.95	7
20525	836.5	21.46	1	20.31	107.4	7
20635	847.5	21.62	1	20.47	111.43	7



CHANNEL BANDWIDTH: 5MHz QPSK

Channel	Frequency (MHz)	Conducted Power (dBm)	G _{T-Lc} (dB)	ERP (dBm)	ERP (mW)	Limit (W)
20425	826.5	22.88	1	21.73	148.94	7
20525	836.5	22.89	1	21.74	149.28	7
20625	846.5	23.08	1	21.93	155.96	7

CHANNEL BANDWIDTH: 5MHz 16QAM

Channel	Frequency (MHz)	Conducted Power (dBm)	G _{T-Lc} (dB)	ERP (dBm)	ERP (mW)	Limit (W)
20425	826.5	21.37	1	20.22	105.2	7
20525	836.5	21.42	1	20.27	106.41	7
20625	846.5	21.62	1	20.47	111.43	7

CHANNEL BANDWIDTH: 10MHz QPSK

Channel	Frequency (MHz)	Conducted Power (dBm)	G _{T-Lc} (dB)	ERP (dBm)	ERP (mW)	Limit (W)
20450	829.0	22.93	1	21.78	150.66	7
20525	836.5	22.96	1	21.81	151.71	7
20600	844.0	23.13	1	21.98	157.76	7

CHANNEL BANDWIDTH: 10MHz 16QAM

Channel	Frequency (MHz)	Conducted Power (dBm)	G _{T-Lc} (dB)	ERP (dBm)	ERP (mW)	Limit (W)
20450	829.0	21.44	1	20.29	106.91	7
20525	836.5	21.47	1	20.32	107.65	7
20600	844.0	21.64	1	20.49	111.94	7

REMARKS: ERP Output Power (dBm) = EIRP (dBm) -2.15(dB).

3.2 FREQUENCY STABILITY MEASUREMENT

3.2.1 LIMITS OF FREQUENCY STABILITY MEASUREMENT

1.5 ppm is for base and fixed station. 2.5 ppm is for mobile station.

3.2.2 TEST PROCEDURE

- a. Device is placed at the oven room. The oven room could control the temperatures and humidity. Power warm up is at least 15 min and power applied should perform before recording frequency error.
- b. EUT is connected the external power supply to control the DC input power. The test voltage range is from minimum to maximum working voltage. Each step shall be record the frequency error rate.
- c. The temperature range step is 10 degrees in this test items. All temperature levels shall be hold the $\pm 0.5^{\circ}\text{C}$ during the measurement testing. The each temperature step shall be at least 0.5 hours, consider the EUT could be test under the stability condition.

NOTE: The frequency error was recorded frequency error from the communication simulator.

3.2.3 TEST SETUP

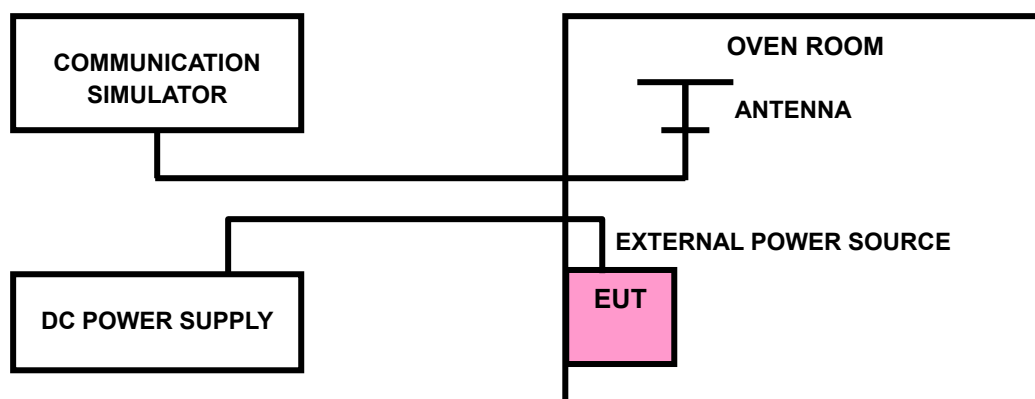



Test Report No.: W7L-P22010007RF02

3.2.4 TEST RESULTS

Please Refer to Appendix Of this test report.

3.3 OCCUPIED BANDWIDTH MEASUREMENT

3.3.1 TEST PROCEDURES

The EUT makes a call to the communication simulator. All measurements were done at low, middle and high operational frequency range. The communication simulator station system controlled a EUT to export maximum output power under transmission mode and specific channel frequency. Use OBW measurement function of Spectrum analyzer to measure 99 % occupied bandwidth.

3.3.2 TEST SETUP

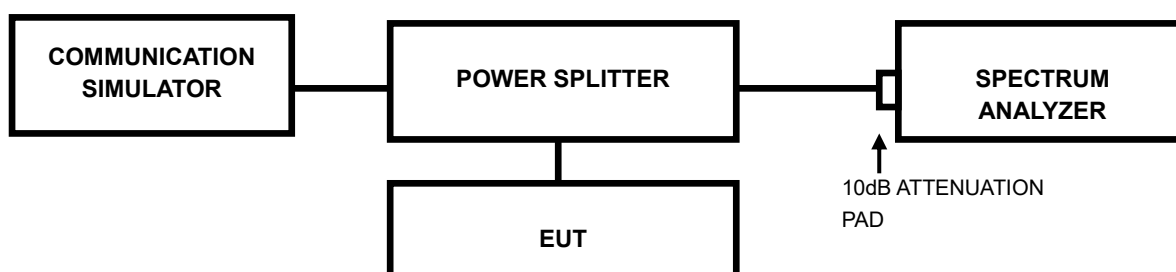



BUREAU
VERITAS

Test Report No.: W7L-P22010007RF02

3.3.3 TEST RESULTS

Please Refer to Appendix Of this test report.

3.4 BAND EDGE MEASUREMENT

3.4.1 LIMITS OF BAND EDGE MEASUREMENT

Power of any emission outside of the authorized operating frequency ranges must be attenuated below the transmitting power (P) by a factor of at least $43 + 10 \log(P)$ dB. In the 1 MHz bands immediately outside and adjacent to the frequency block a resolution bandwidth of at least one percent of the emission bandwidth of the fundamental emission of the transmitter may be employed.

3.4.2 TEST SETUP

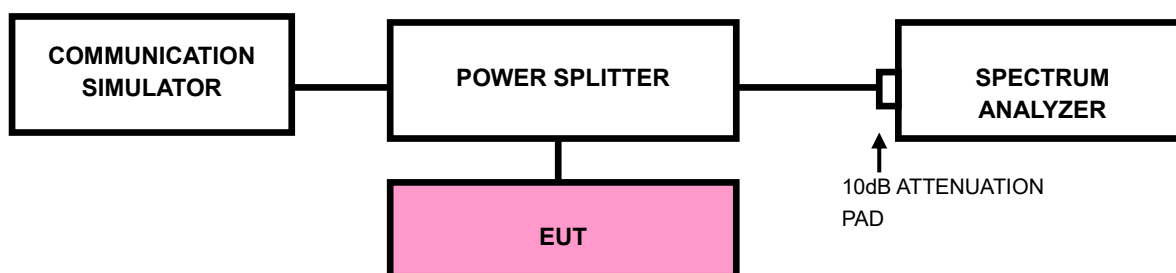



**BUREAU
VERITAS**

Test Report No.: W7L-P22010007RF02

3.4.3 TEST PROCEDURES

- a. All measurements were done at low and high operational frequency range.
- b. The center frequency of spectrum is the band edge frequency and span is 1~5 MHz.
RBW of the spectrum is 10kHz and VBW of the spectrum is 30kHz (LTE bandwidth for (1.4M/3M/5M/10M/15M/20M)1RB/0RB&1RB/MAXRB).
- c. The center frequency of spectrum is the band edge frequency and span is 10MHz.
RBW of the spectrum is 100kHz and VBW of the spectrum is 300kHz (WCDMA).
- d. The center frequency of spectrum is the band edge frequency and span is 1~5 MHz.
RBW of the spectrum is $\geq 1\% \cdot \text{EBW}$ kHz and VBW of the spectrum is $3 \cdot \text{RBW}$ kHz. (LTE bandwidth 1.4M/3M/5M/10M/15M/20MHz).
- e. Record the max trace plot into the test report.



BUREAU
VERITAS

Test Report No.: W7L-P22010007RF02

3.4.4 TEST RESULTS

Please Refer to Appendix Of this test report.

3.5 CONDUCTED SPURIOUS EMISSIONS

3.5.1 LIMITS OF CONDUCTED SPURIOUS EMISSIONS MEASUREMENT

The power of any emission outside of the authorized operating frequency ranges must be attenuated below the transmitting power (P) by a factor of at least $43 + 10 \log(P)$ dB. The emission limit equal to -13dBm .

3.5.2 TEST PROCEDURE

- a. The EUT makes a phone call to the communication simulator. All measurements were done at low, middle and high operational frequency range.
- b. Measuring frequency range is from 9kHz up to a frequency including its 10th harmonic. 10dB attenuation pad is connected with spectrum. RBW=1MHz and VBW=3MHz is used for conducted emission measurement.

3.5.3 TEST SETUP

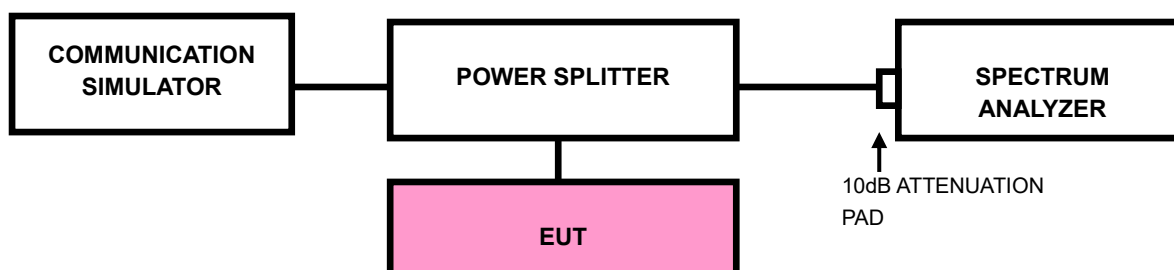



**BUREAU
VERITAS**

Test Report No.: W7L-P22010007RF02

3.5.4 TEST RESULTS

NOTE : The 9K~30MHz amplitude of spurious emissions attenuated more than 20 dB below the permissible value is not required in the report.

Please Refer to Appendix Of this test report.



3.6 RADIATED EMISSION MEASUREMENT

3.6.1 LIMITS OF RADIATED EMISSION MEASUREMENT

The power of any emission outside of the authorized operating frequency ranges must be attenuated below the transmitting power (P) by a factor of at least $43 + 10 \log(P)$ dB. The emission limit equal to -13dBm .

3.6.2 TEST PROCEDURES

- a. Substitution method is used for E.I.R.P measurement. In the semi-anechoic chamber, EUT placed on the 0.8m height of Turn Table, rotated the table around 360 degrees to search the maximum radiation power and receiver antenna shall be rotated vertical and horizontal polarization and moved height from 1m to 4m to find the maximum polar radiated power. The "Read Value" is the spectrum reading the maximum power value.
- b. The substitution horn antenna is substituted for EUT at the same position and signals generator export the CW signal to the substitution antenna via a TX cable. Rotated the Turn Table and moved receiving antenna to find the maximum radiation power. Adjust output power level of S.G to get a Value of spectrum reading equal to "Read Value " of step a. Record the power level of S.G
- c. $\text{EIRP} = \text{Output power level of S.G} - \text{TX cable loss} + \text{Antenna gain of substitution horn}$.
- d. E.R.P power can be calculated form E.I.R.P power by subtracting the gain of dipole, $\text{E.R.P power} = \text{E.I.P.R power} - 2.15\text{dBi}$.

NOTE: The resolution bandwidth and video bandwidth of test receiver/spectrum analyzer is 1MHz/3MHz.

3.6.3 DEVIATION FROM TEST STANDARD

No deviation



3.6.4 TEST SETUP

< Frequency Range 30MHz~1GHz >

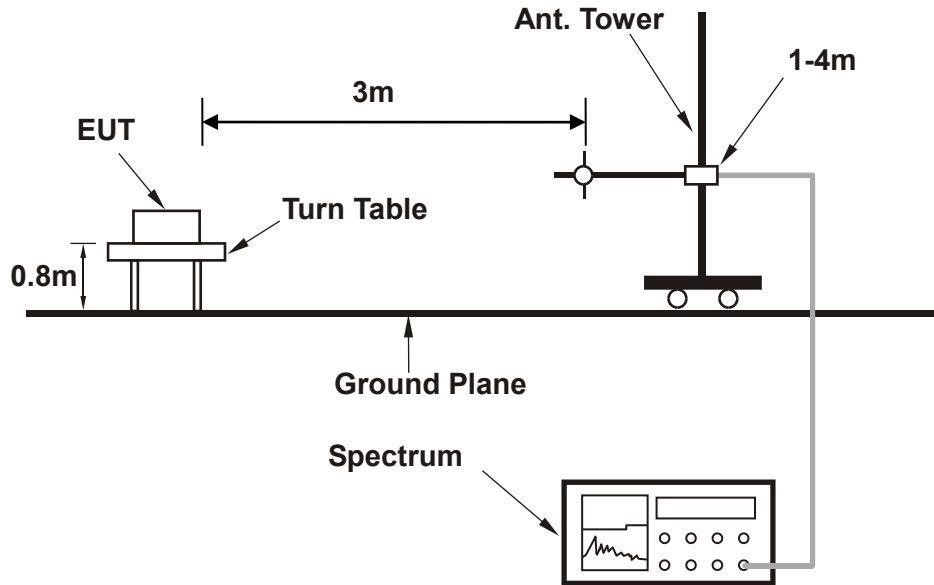

<Frequency Range above 1GHz>

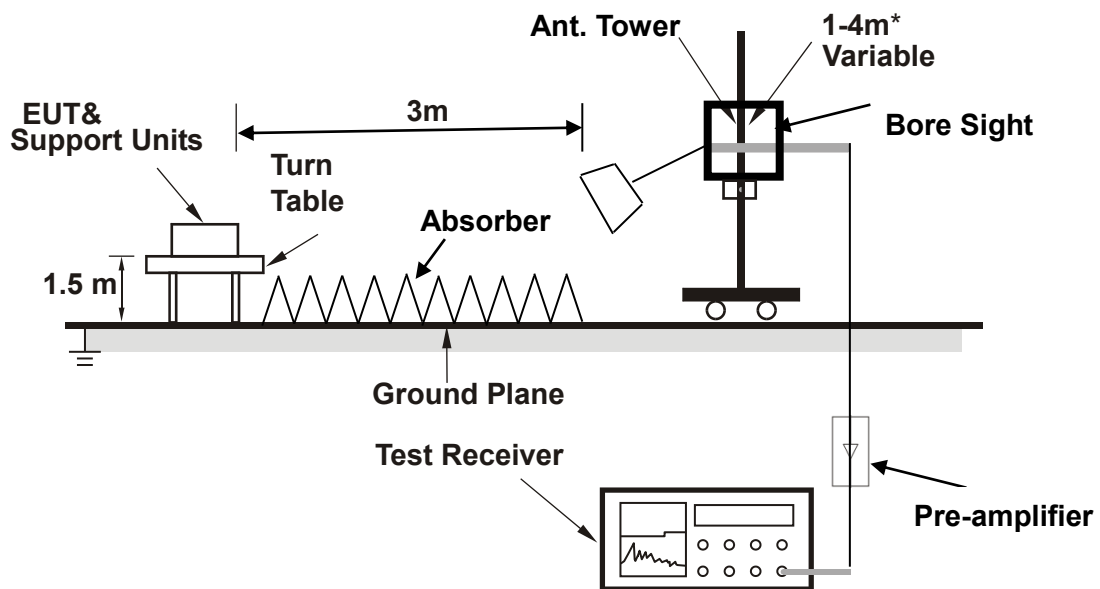

Note: Above 1G is a directional antenna

Depends on the EUT height and the antenna 3dB beamwidth both, refer to section 7.3 of CISPR 16-2-3.

For the actual test configuration, please refer to the attached file (Test Setup Photo).



3.6.5 TEST RESULTS

BELOW 1GHz WORST-CASE DATA

30 MHz – 1GHz data:

WCDMA Band V:

CHANNEL BANDWIDTH: 4132 ~ 4233

MODE	TX channel 4233	FREQUENCY RANGE	Below 1000MHz
ENVIRONMENTAL CONDITIONS	23deg. C, 70%RH	INPUT POWER	AC 120V/60Hz
TESTED BY	Jace Hu		
ANTENNA POLARITY & TEST DISTANCE: HORIZONTAL AT 3 M			

	Freq	Level	Read Level	Limit Line	Over Limit	Factor	Remark	Pol/Phase	
	MHz	dBm/m	dBm	dBm/m	dB	dB/m			
1	PP	80.440	-31.44	-39.34	-13.00	-18.44	7.90	Peak	Horizontal
2		189.080	-33.44	-44.00	-13.00	-20.44	10.56	Peak	Horizontal
3		282.200	-34.51	-48.23	-13.00	-21.51	13.72	Peak	Horizontal
4		404.420	-40.49	-57.47	-13.00	-27.49	16.98	Peak	Horizontal
5		461.650	-38.34	-56.35	-13.00	-25.34	18.01	Peak	Horizontal
6		629.460	-32.67	-53.96	-13.00	-19.67	21.29	Peak	Horizontal

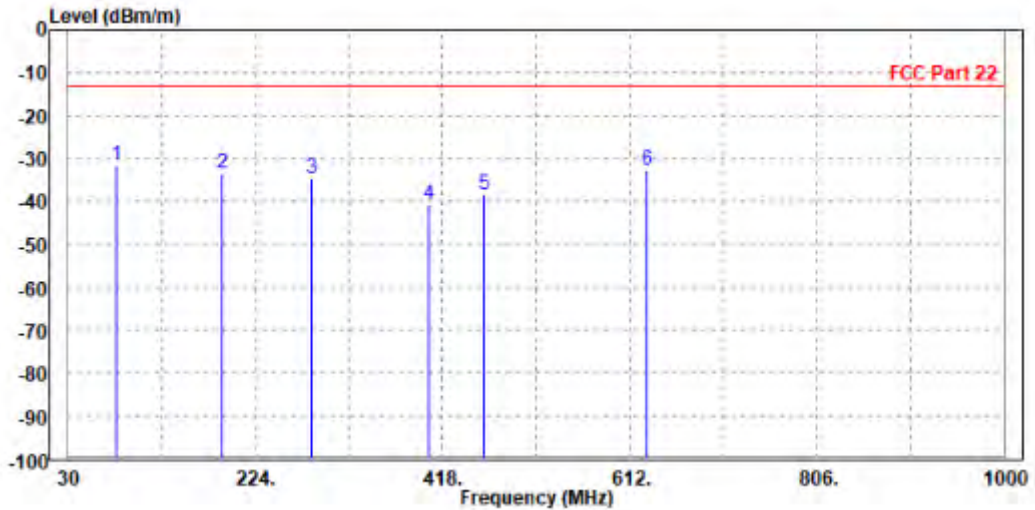



**BUREAU
VERITAS**

Test Report No.: W7L-P22010007RF02

MODE	TX channel 4233	FREQUENCY RANGE	Below 1000MHz
ENVIRONMENTAL CONDITIONS	23deg. C, 70%RH	INPUT POWER	AC 120V/60Hz
TESTED BY	Jace Hu		
ANTENNA POLARITY & TEST DISTANCE: VERTICAL AT 3 M			

	Freq	Level	Read Level	Limit Line	Over Limit	Factor	Remark	Pol/Phase
	MHz	dBm/m	dBm	dBm/m	dB	dB/m		
1	PP	41.640	-30.37	-42.05	-13.00	-17.37	11.68 Peak	Vertical
2		80.440	-32.30	-40.61	-13.00	-19.30	8.31 Peak	Vertical
3		201.690	-35.36	-46.94	-13.00	-22.36	11.58 Peak	Vertical
4		284.140	-35.78	-50.40	-13.00	-22.78	14.62 Peak	Vertical
5		463.590	-39.84	-58.25	-13.00	-26.84	18.41 Peak	Vertical
6		630.430	-36.26	-57.59	-13.00	-23.26	21.33 Peak	Vertical

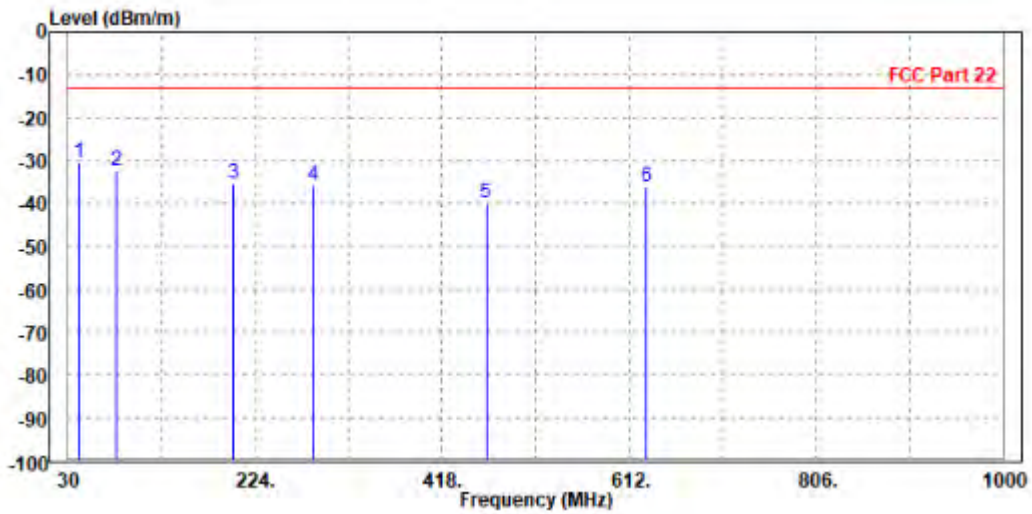



**BUREAU
VERITAS**

Test Report No.: W7L-P22010007RF02

ABOVE 1GHz DATA

Note: For higher frequency, the emission is too low to be detected.

WCDMA Band V:

CH 4132:

MODE	TX channel 4132	FREQUENCY RANGE	Above 1000MHz
ENVIRONMENTAL CONDITIONS	23deg. C, 70%RH	INPUT POWER	AC 120V/60Hz
TESTED BY	Jace Hu		
ANTENNA POLARITY & TEST DISTANCE: HORIZONTAL AT 3 M			

	Freq	Level	Read Level	Limit Line	Over Limit	Factor	Remark	Pol/Phase
	MHz	dBm/m	dBm	dBm/m	dB	dB/m		
1	1648.000	-31.04	-34.29	-13.00	-18.04	3.25	Peak	Horizontal
2 PP	2476.000	-28.82	-36.85	-13.00	-15.82	8.03	Peak	Horizontal

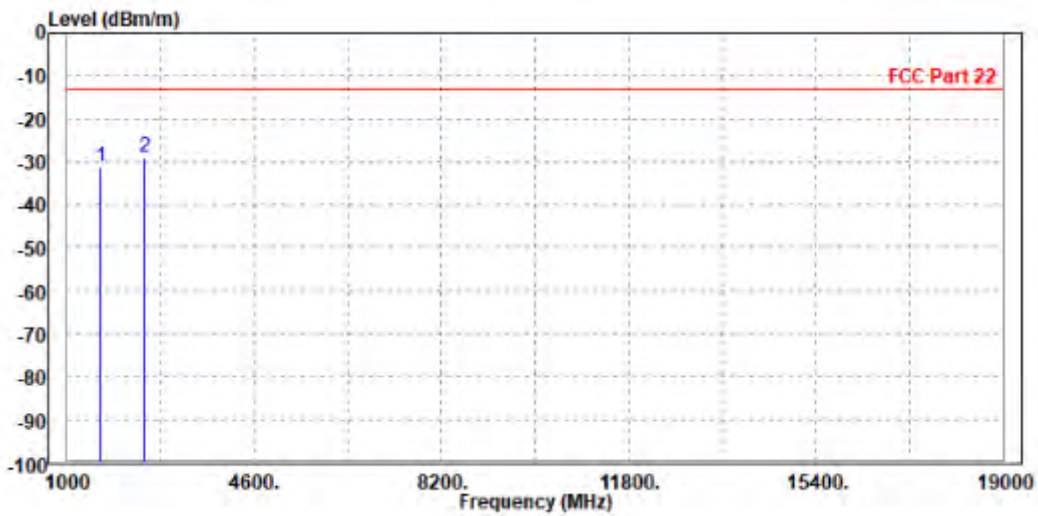



Test Report No.: W7L-P22010007RF02

MODE	TX channel 4132	FREQUENCY RANGE	Above 1000MHz
ENVIRONMENTAL CONDITIONS	23deg. C, 70%RH	INPUT POWER	AC 120V/60Hz
TESTED BY	Jace Hu		
ANTENNA POLARITY & TEST DISTANCE: VERTICAL AT 3 M			

	Freq	Level	Read Level	Limit Line	Over Limit	Factor	Remark	Pol/Phase
	MHz	dBm/m	dBm	dBm/m	dB	dB/m		
1	1652.800	-33.77	-37.20	-13.00	-20.77	3.43	Peak	Vertical
2 PP	2476.000	-26.58	-33.62	-13.00	-13.58	7.04	Peak	Vertical

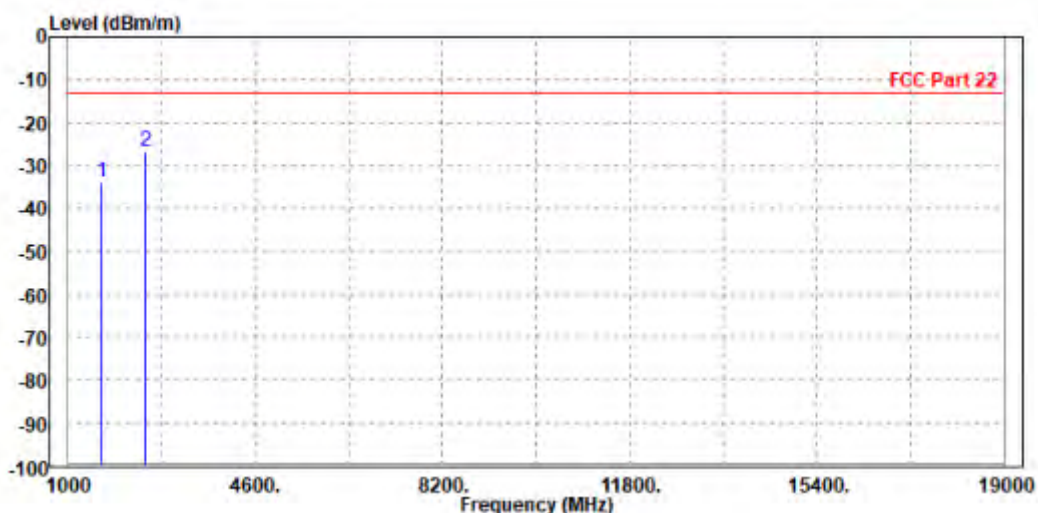



**BUREAU
VERITAS**

Test Report No.: W7L-P22010007RF02

CH 4182:

MODE	TX channel 4182	FREQUENCY RANGE	Above 1000MHz
ENVIRONMENTAL CONDITIONS	23deg. C, 70%RH	INPUT POWER	AC 120V/60Hz
TESTED BY	Jace Hu		
ANTENNA POLARITY & TEST DISTANCE: HORIZONTAL AT 3 M			

	Freq	Level	Read Level	Limit Line	Over Limit	Factor	Remark	Pol/Phase
	MHz	dBm/m	dBm	dBm/m	dB	dB/m		
1 PP	1666.000	-30.84	-34.31	-13.00	-17.84	3.47	Peak	Horizontal
2	2509.200	-40.62	-48.68	-13.00	-27.62	8.06	Peak	Horizontal

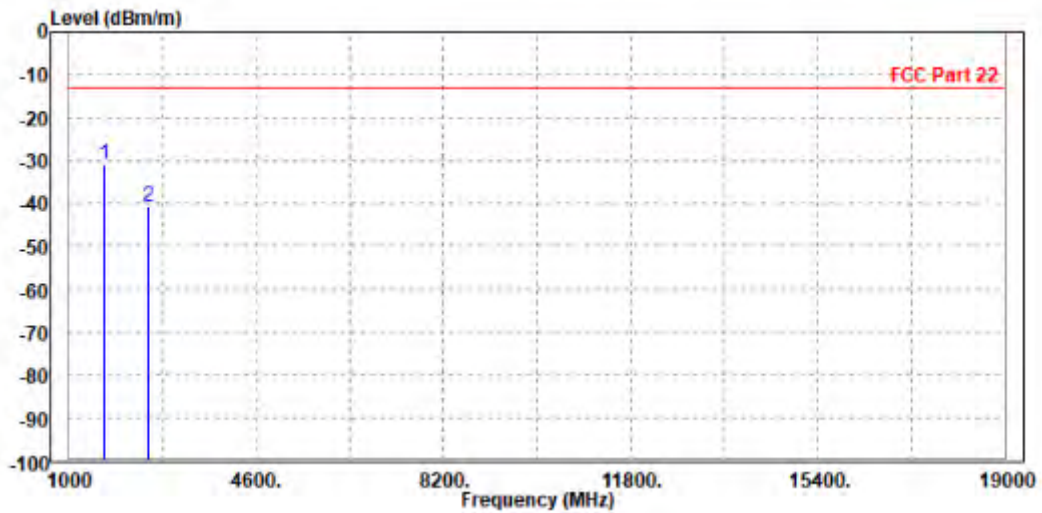



**BUREAU
VERITAS**

Test Report No.: W7L-P22010007RF02

MODE	TX channel 4182	FREQUENCY RANGE	Above 1000MHz
ENVIRONMENTAL CONDITIONS	23deg. C, 70%RH	INPUT POWER	AC 120V/60Hz
TESTED BY	Jace Hu		
ANTENNA POLARITY & TEST DISTANCE: VERTICAL AT 3 M			

	Freq	Level	Read Level	Limit Line	Over Limit	Factor	Remark	Pol/Phase
	MHz	dBm/m	dBm	dBm/m	dB	dB/m		
1	PP 1672.800	-37.15	-40.76	-13.00	-24.15	3.61	Peak	Vertical
2	2512.000	-40.42	-47.53	-13.00	-27.42	7.11	Peak	Vertical

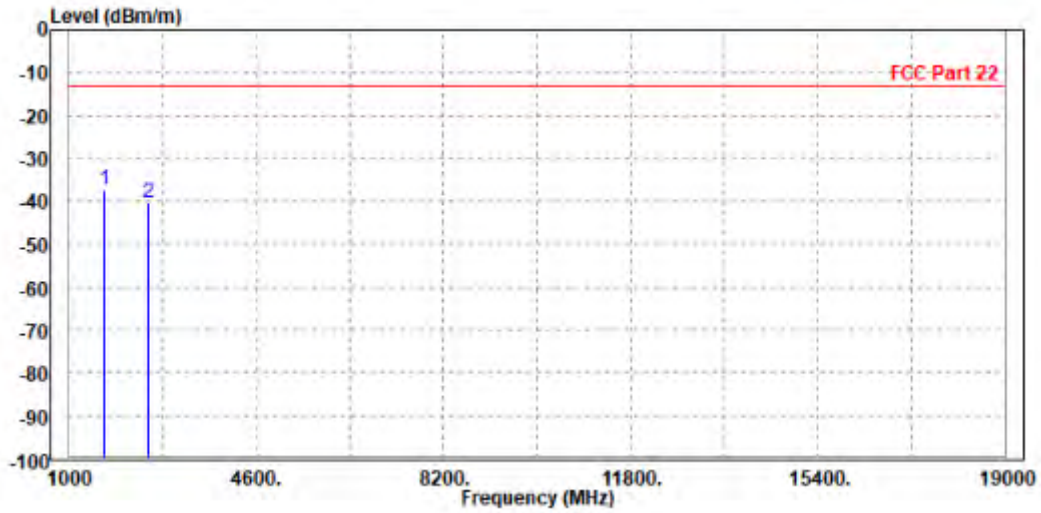



CH 4233:

MODE	TX channel 4233	FREQUENCY RANGE	Above 1000MHz
ENVIRONMENTAL CONDITIONS	23deg. C, 70%RH	INPUT POWER	AC 120V/60Hz
TESTED BY	Jace Hu		
ANTENNA POLARITY & TEST DISTANCE: HORIZONTAL AT 3 M			

	Freq	Level	Read Level	Limit Line	Over Limit	Factor	Remark	Pol/Phase
	MHz	dBm/m	dBm	dBm/m	dB	dB/m		
1	PP 1693.200	-29.95	-33.75	-13.00	-16.95	3.80	Peak	Horizontal
2	2548.000	-36.46	-44.57	-13.00	-23.46	8.11	Peak	Horizontal

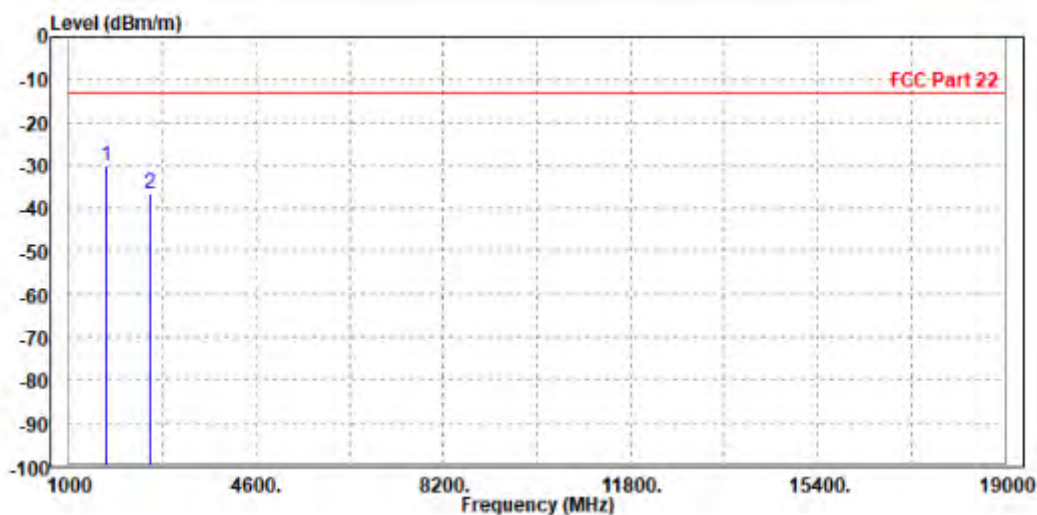



Test Report No.: W7L-P22010007RF02

MODE	TX channel 4233	FREQUENCY RANGE	Above 1000MHz
ENVIRONMENTAL CONDITIONS	23deg. C, 70%RH	INPUT POWER	AC 120V/60Hz
TESTED BY	Jace Hu		
ANTENNA POLARITY & TEST DISTANCE: VERTICAL AT 3 M			

	Freq	Level	Read Level	Limit Line	Over Limit	Factor	Remark	Pol/Phase
	MHz	dBm/m	dBm	dBm/m	dB	dB/m		
1	PP 1702.000	-37.41	-41.28	-13.00	-24.41	3.87	Peak	Vertical
2	2539.800	-41.59	-48.79	-13.00	-28.59	7.20	Peak	Vertical

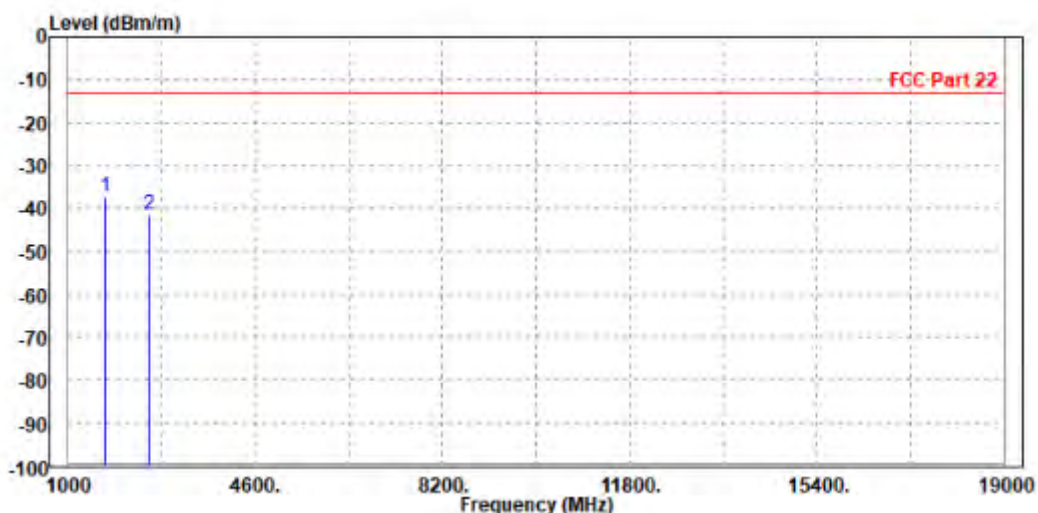



**BUREAU
VERITAS**

Test Report No.: W7L-P22010007RF02

LTE Band 5

CHANNEL BANDWIDTH: 1.4MHz / QPSK

MODE	TX channel 20525	FREQUENCY RANGE	Above 1000MHz
ENVIRONMENTAL CONDITIONS	23deg. C, 70%RH	INPUT POWER	AC 120V/60Hz
TESTED BY	Jace Hu		
ANTENNA POLARITY & TEST DISTANCE: HORIZONTAL AT 3 M			

	Freq	Level	Read Level	Limit Line	Over Limit	Factor	Remark	Pol/Phase
	MHz	dBm/m	dBm	dBm/m	dB	dB/m		
1	1666.000	-52.12	-55.59	-13.00	-39.12	3.47	Peak	Horizontal
2 PP	2509.500	-46.24	-54.30	-13.00	-33.24	8.06	Peak	Horizontal

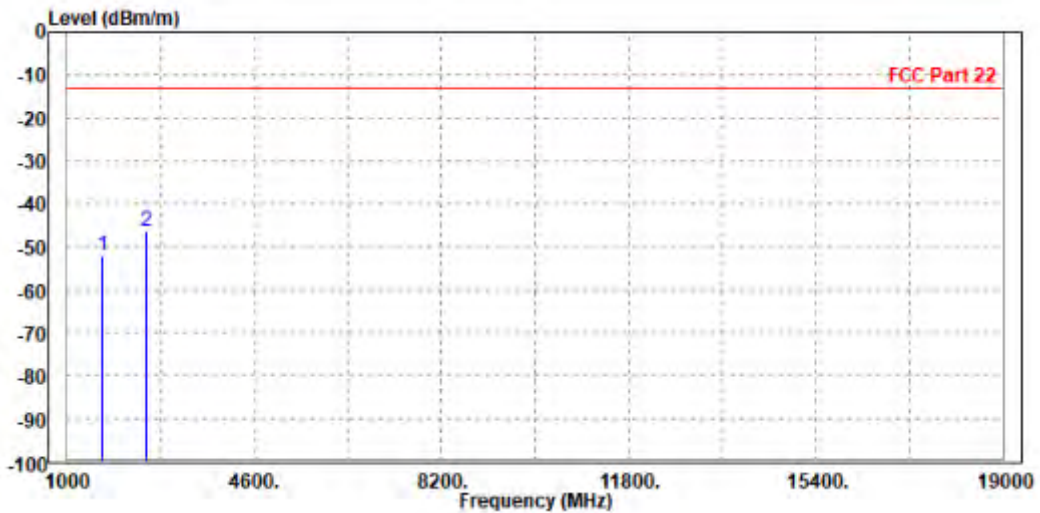



**BUREAU
VERITAS**

Test Report No.: W7L-P22010007RF02

MODE	TX channel 20525	FREQUENCY RANGE	Above 1000MHz
ENVIRONMENTAL CONDITIONS	23deg. C, 70%RH	INPUT POWER	AC 120V/60Hz
TESTED BY	Jace Hu		
ANTENNA POLARITY & TEST DISTANCE: VERTICAL AT 3 M			

	Freq	Level	Read Level	Limit Line	Over Limit	Factor	Remark	Pol/Phase
	MHz	dBm/m	dBm	dBm/m	dB	dB/m		
1	1666.000	-52.69	-56.23	-13.00	-39.69	3.54	Peak	Vertical
2 PP	2509.500	-48.35	-55.45	-13.00	-35.35	7.10	Peak	Vertical

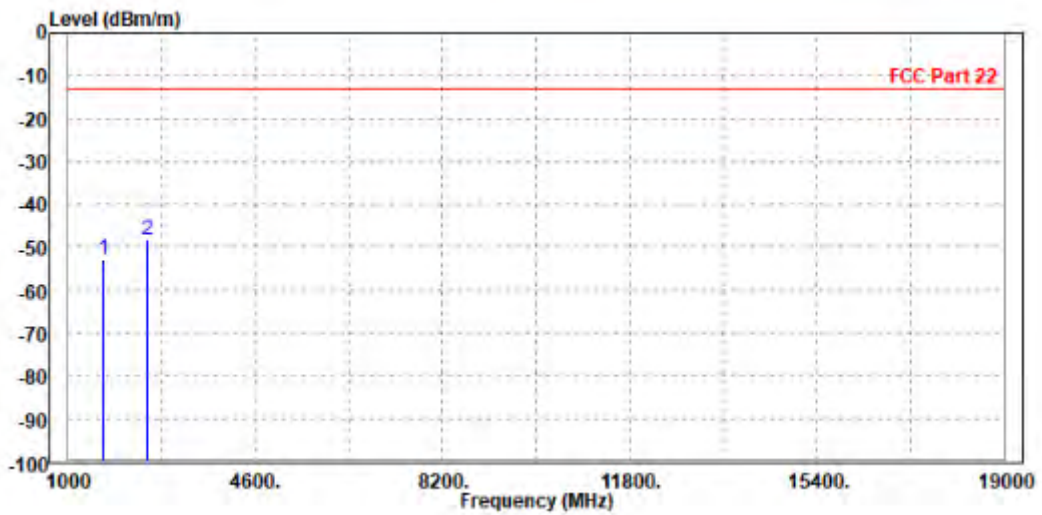



**BUREAU
VERITAS**

Test Report No.: W7L-P22010007RF02

CHANNEL BANDWIDTH: 3MHz / QPSK

MODE	TX channel 20525	FREQUENCY RANGE	Above 1000MHz
ENVIRONMENTAL CONDITIONS	23deg. C, 70%RH	INPUT POWER	AC 120V/60Hz
TESTED BY	Jace Hu		
ANTENNA POLARITY & TEST DISTANCE: HORIZONTAL AT 3 M			

	Freq	Level	Read Level	Limit Line	Over Limit	Factor	Remark	Pol/Phase
	MHz	dBm/m	dBm	dBm/m	dB	dB/m		
1	1666.000	-50.72	-54.19	-13.00	-37.72	3.47	Peak	Horizontal
2 PP	2509.500	-44.04	-52.10	-13.00	-31.04	8.06	Peak	Horizontal

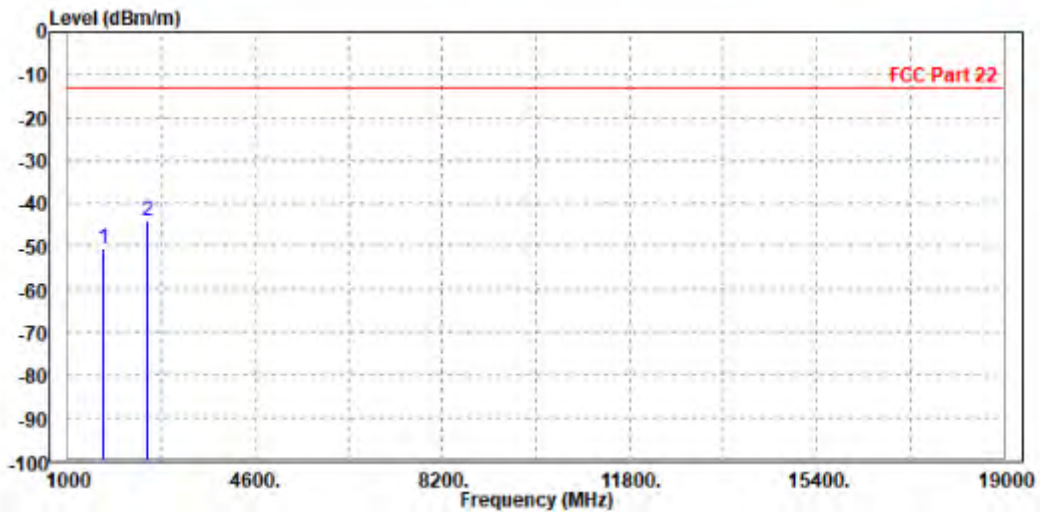



**BUREAU
VERITAS**

Test Report No.: W7L-P22010007RF02

MODE	TX channel 20525	FREQUENCY RANGE	Above 1000MHz
ENVIRONMENTAL CONDITIONS	23deg. C, 70%RH	INPUT POWER	AC 120V/60Hz
TESTED BY	Jace Hu		
ANTENNA POLARITY & TEST DISTANCE: VERTICAL AT 3 M			

	Freq	Level	Read Level	Limit Line	Over Limit	Factor	Remark	Pol/Phase
	MHz	dBm/m	dBm	dBm/m	dB	dB/m		
1	1666.000	-50.05	-53.59	-13.00	-37.05	3.54	Peak	Vertical
2 PP	2509.500	-44.69	-51.79	-13.00	-31.69	7.10	Peak	Vertical

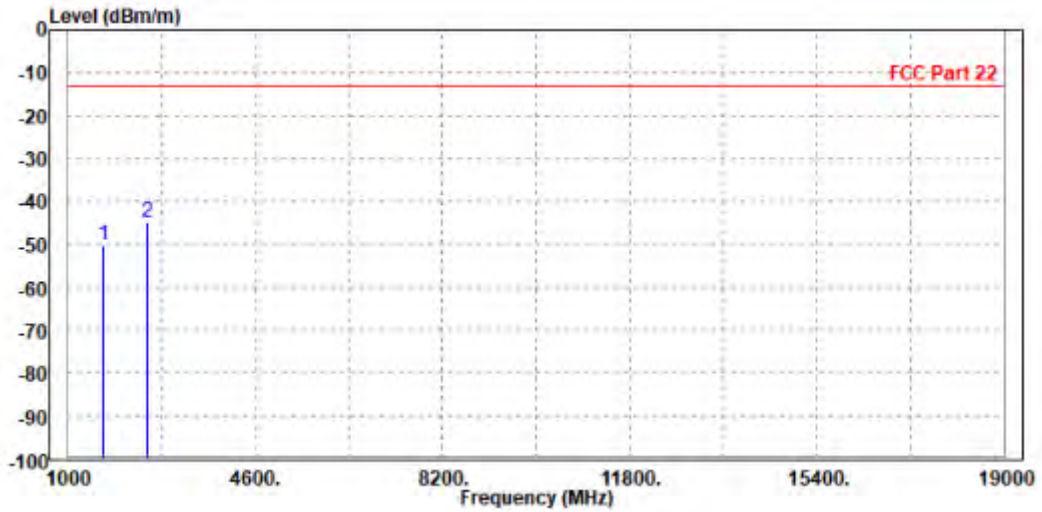



**BUREAU
VERITAS**

Test Report No.: W7L-P22010007RF02

CHANNEL BANDWIDTH: 5MHz / QPSK

MODE	TX channel 20525	FREQUENCY RANGE	Above 1000MHz
ENVIRONMENTAL CONDITIONS	23deg. C, 70%RH	INPUT POWER	AC 120V/60Hz
TESTED BY	Jace Hu		
ANTENNA POLARITY & TEST DISTANCE: HORIZONTAL AT 3 M			

	Freq	Level	Read Level	Limit Line	Over Limit	Factor	Remark	Pol/Phase
	MHz	dBm/m	dBm	dBm/m	dB	dB/m		
1	1666.000	-51.92	-55.39	-13.00	-38.92	3.47	Peak	Horizontal
2 PP	2509.500	-43.96	-52.02	-13.00	-30.96	8.06	Peak	Horizontal

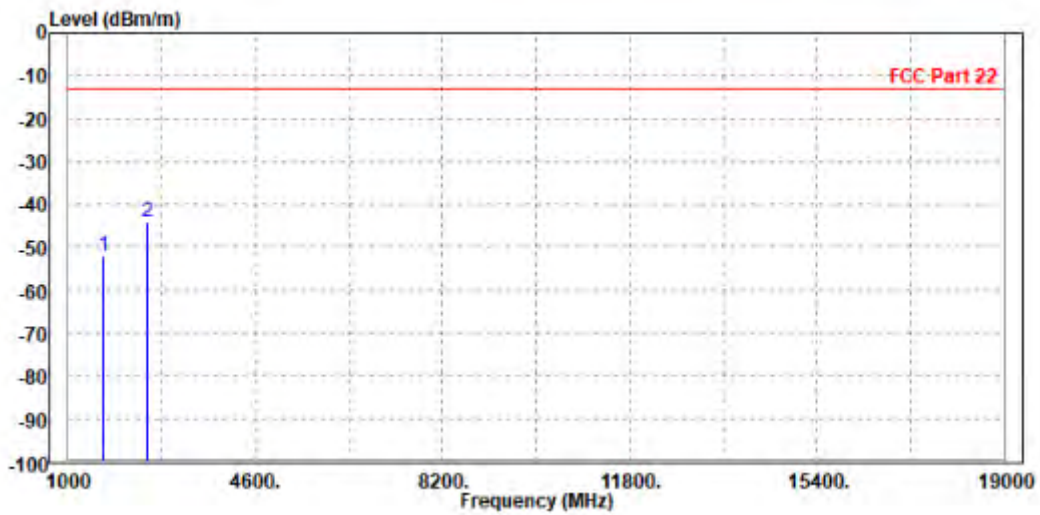



**BUREAU
VERITAS**

Test Report No.: W7L-P22010007RF02

MODE	TX channel 20525	FREQUENCY RANGE	Above 1000MHz
ENVIRONMENTAL CONDITIONS	23deg. C, 70%RH	INPUT POWER	AC 120V/60Hz
TESTED BY	Jace Hu		
ANTENNA POLARITY & TEST DISTANCE: VERTICAL AT 3 M			

	Freq	Level	Read Level	Limit Line	Over Limit	Factor	Remark	Pol/Phase
	MHz	dBm/m	dBm	dBm/m	dB	dB/m		
1	1666.000	-51.65	-55.19	-13.00	-38.65	3.54	Peak	Vertical
2 PP	2509.500	-46.08	-53.18	-13.00	-33.08	7.10	Peak	Vertical

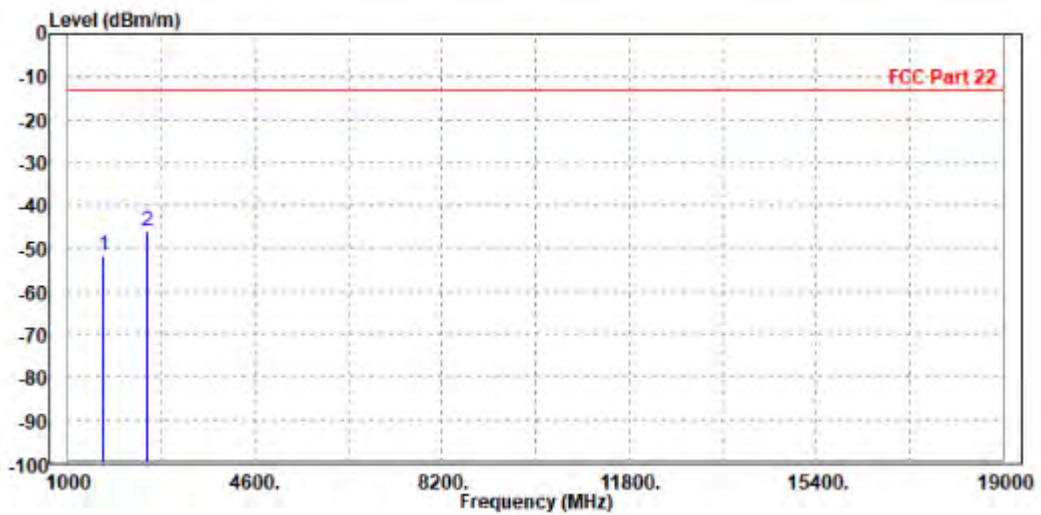



**BUREAU
VERITAS**

Test Report No.: W7L-P22010007RF02

**CHANNEL BANDWIDTH: 10MHz / QPSK
CH20450**

MODE	TX channel 20450	FREQUENCY RANGE	Above 1000MHz
ENVIRONMENTAL CONDITIONS	23deg. C, 70%RH	INPUT POWER	AC 120V/60Hz
TESTED BY	Jace Hu		
ANTENNA POLARITY & TEST DISTANCE: HORIZONTAL AT 3 M			

	Freq	Level	Read Level	Limit Line	Over Limit	Factor	Remark	Pol/Phase
	MHz	dBm/m	dBm	dBm/m	dB	dB/m		
1	1666.000	-50.96	-54.43	-13.00	-37.96	3.47	Peak	Horizontal
2 PP	2487.000	-45.17	-53.21	-13.00	-32.17	8.04	Peak	Horizontal

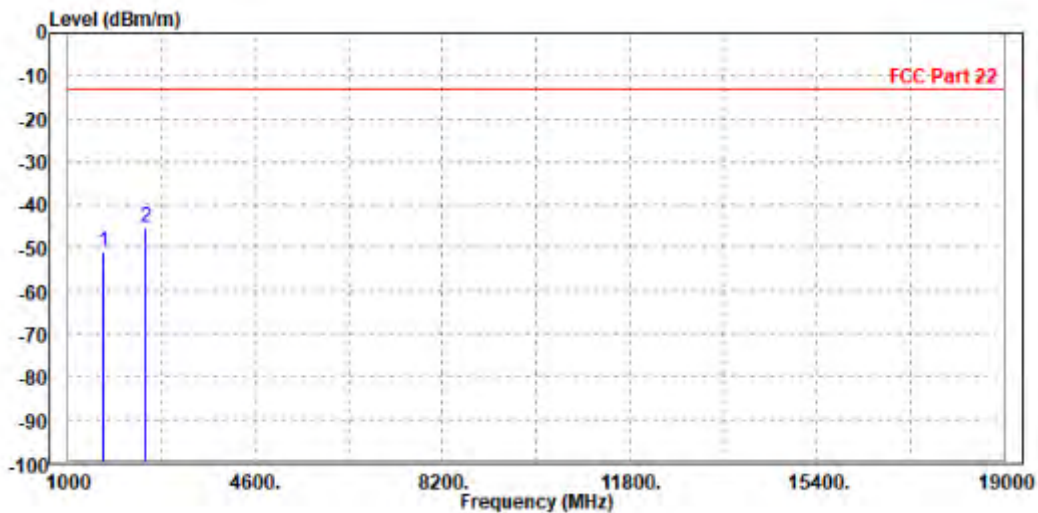



**BUREAU
VERITAS**

Test Report No.: W7L-P22010007RF02

MODE	TX channel 20450	FREQUENCY RANGE	Above 1000MHz
ENVIRONMENTAL CONDITIONS	23deg. C, 70%RH	INPUT POWER	AC 120V/60Hz
TESTED BY	Jace Hu		
ANTENNA POLARITY & TEST DISTANCE: VERTICAL AT 3 M			

	Freq	Level	Read Level	Limit Line	Over Limit	Factor	Remark	Pol/Phase
	MHz	dBm/m	dBm	dBm/m	dB	dB/m		
1	1666.000	-52.09	-55.63	-13.00	-39.09	3.54	Peak	Vertical
2 PP	2487.000	-46.30	-53.35	-13.00	-33.30	7.05	Peak	Vertical

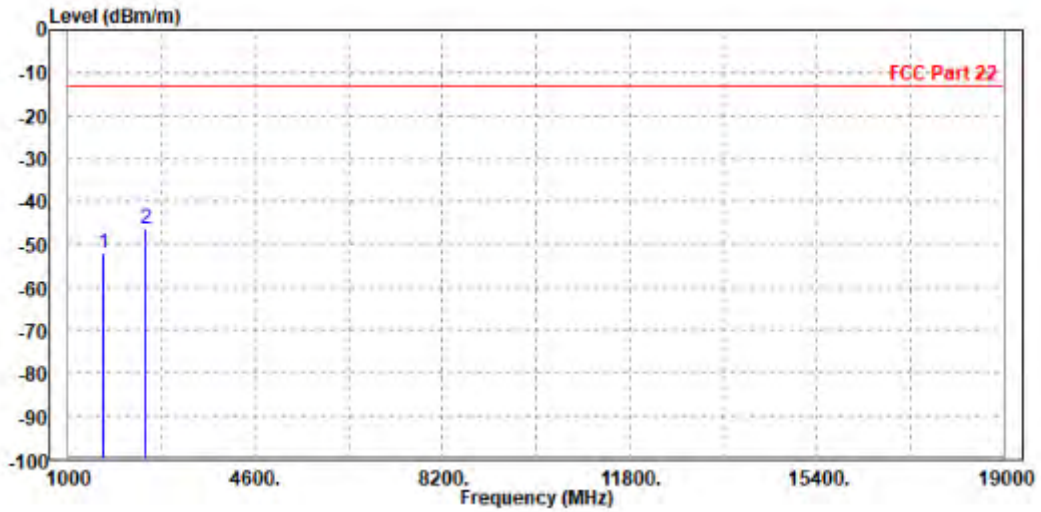



**BUREAU
VERITAS**

Test Report No.: W7L-P22010007RF02

CH20525

MODE	TX channel 20525	FREQUENCY RANGE	Above 1000MHz
ENVIRONMENTAL CONDITIONS	23deg. C, 70%RH	INPUT POWER	AC 120V/60Hz
TESTED BY	Jace Hu		
ANTENNA POLARITY & TEST DISTANCE: HORIZONTAL AT 3 M			

	Freq	Level	Read Level	Limit Line	Over Limit	Factor	Remark	Pol/Phase
	MHz	dBm/m	dBm	dBm/m	dB	dB/m		
1	1666.000	-51.74	-55.21	-13.00	-38.74	3.47	Peak	Horizontal
2 PP	2509.500	-42.19	-50.25	-13.00	-29.19	8.06	Peak	Horizontal

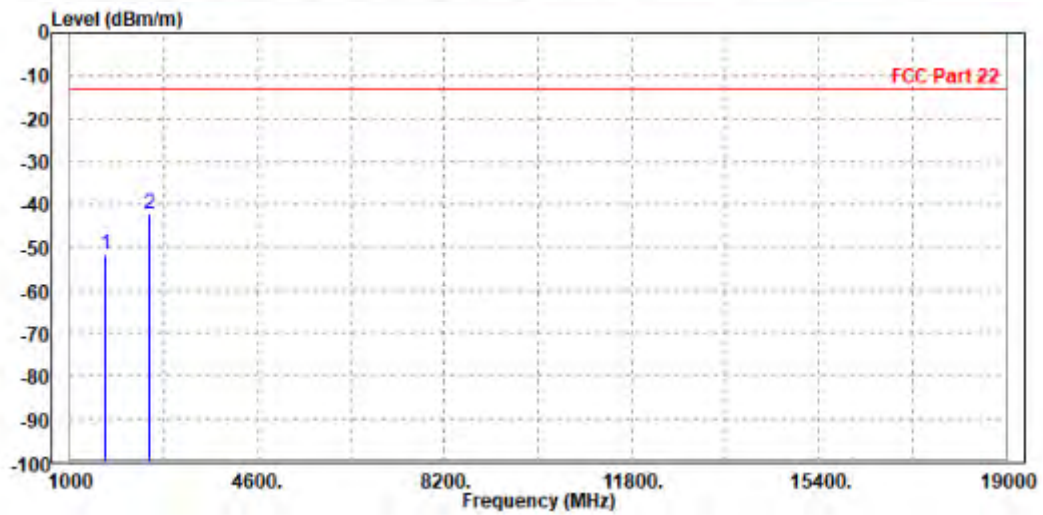



**BUREAU
VERITAS**

Test Report No.: W7L-P22010007RF02

MODE	TX channel 20525	FREQUENCY RANGE	Above 1000MHz
ENVIRONMENTAL CONDITIONS	23deg. C, 70%RH	INPUT POWER	AC 120V/60Hz
TESTED BY	Jace Hu		
ANTENNA POLARITY & TEST DISTANCE: VERTICAL AT 3 M			

	Freq	Level	Read Level	Limit Line	Over Limit	Factor	Remark	Pol/Phase
	MHz	dBm/m	dBm	dBm/m	dB	dB/m		
1	1666.000	-52.10	-55.64	-13.00	-39.10	3.54	Peak	Vertical
2 PP	2509.500	-45.44	-52.54	-13.00	-32.44	7.10	Peak	Vertical

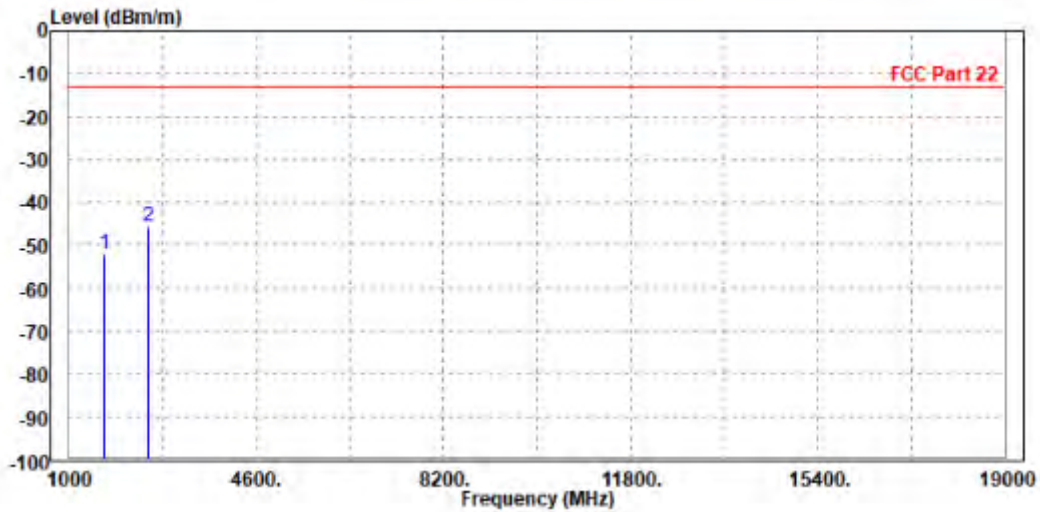



**BUREAU
VERITAS**

Test Report No.: W7L-P22010007RF02

CH20600

MODE	TX channel 20600	FREQUENCY RANGE	Above 1000MHz
ENVIRONMENTAL CONDITIONS	23deg. C, 70%RH	INPUT POWER	AC 120V/60Hz
TESTED BY	Jace Hu		
ANTENNA POLARITY & TEST DISTANCE: HORIZONTAL AT 3 M			

	Freq	Level	Read Level	Limit Line	Over Limit	Factor	Remark	Pol/Phase
	MHz	dBm/m	dBm	dBm/m	dB	dB/m		
1	1688.000	-51.26	-55.00	-13.00	-38.26	3.74	Peak	Horizontal
2 PP	2530.000	-41.38	-49.47	-13.00	-28.38	8.09	Peak	Horizontal

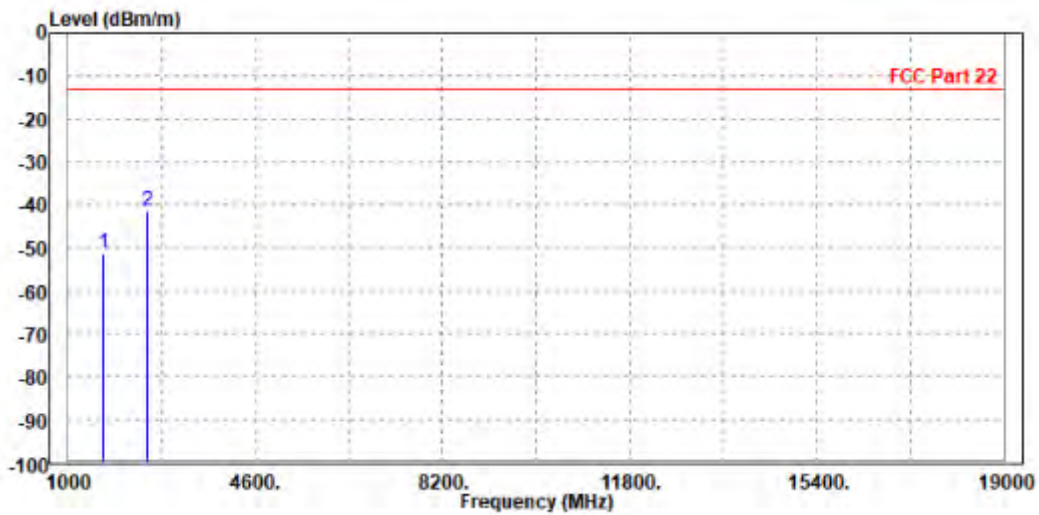



**BUREAU
VERITAS**

Test Report No.: W7L-P22010007RF02

MODE	TX channel 20600	FREQUENCY RANGE	Above 1000MHz
ENVIRONMENTAL CONDITIONS	23deg. C, 70%RH	INPUT POWER	AC 120V/60Hz
TESTED BY	Jace Hu		
ANTENNA POLARITY & TEST DISTANCE: VERTICAL AT 3 M			

	Freq	Level	Read Level	Limit Line	Over Limit	Factor	Remark	Pol/Phase
	MHz	dBm/m	dBm	dBm/m	dB	dB/m		
1	1684.000	-51.46	-55.17	-13.00	-38.46	3.71	Peak	Vertical
2 PP	2532.000	-44.69	-51.86	-13.00	-31.69	7.17	Peak	Vertical

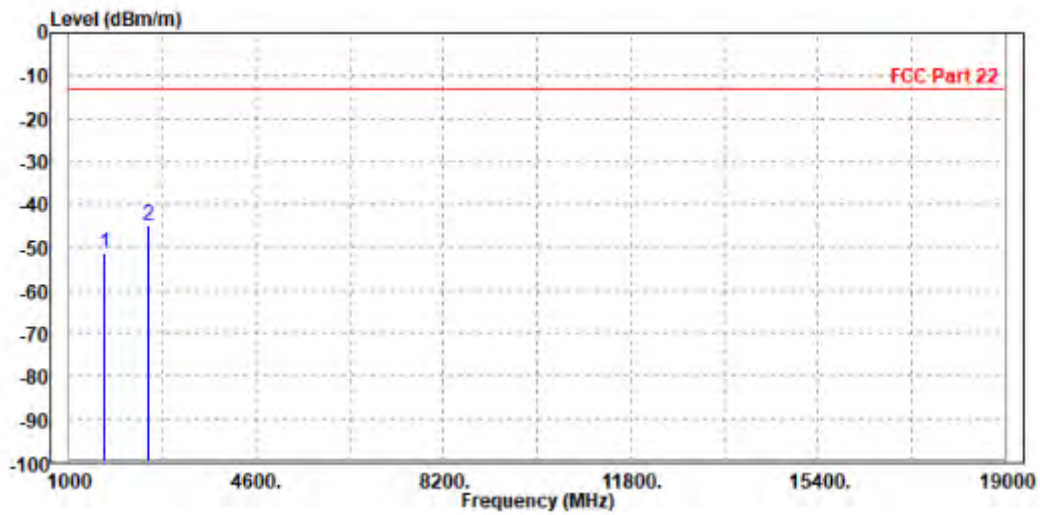

3.7 PEAK TO AVERAGE RATIO

3.7.1 LIMITS OF PEAK TO AVERAGE RATIO MEASUREMENT

In measuring transmissions in this band using an average power technique, the peak to-average ratio (PAR) of the transmission may not exceed 13 dB

3.7.2 TEST SETUP

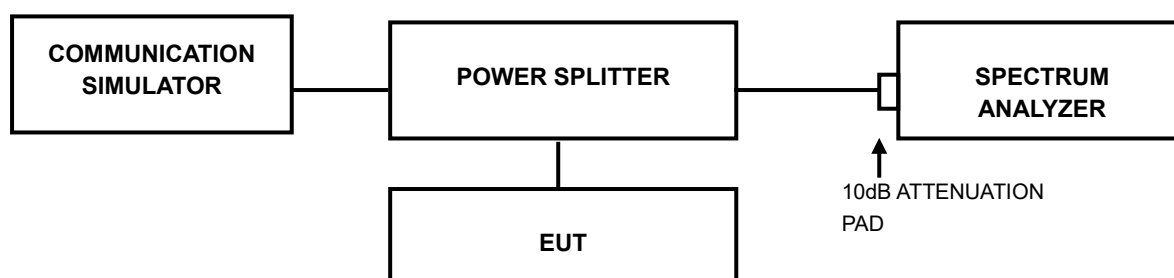

3.7.3 TEST PROCEDURES

1. Set resolution/measurement bandwidth \geq signal's occupied bandwidth;
2. Set the number of counts to a value that stabilizes the measured CCDF curve;
3. Record the maximum PAPR level associated with a probability of 0.1%.



BUREAU
VERITAS

Test Report No.: W7L-P22010007RF02

3.7.4 TEST RESULTS

Please Refer to Appendix Of this test report.



BUREAU
VERITAS

Test Report No.: W7L-P22010007RF02

4 PHOTOGRAPHS OF THE TEST CONFIGURATION

Please refer to the attached file (Test Setup Photo).



Test Report No.: W7L-P22010007RF02

5 INFORMATION ON THE TESTING LABORATORIES

We, BV 7LAYERS COMMUNICATIONS TECHNOLOGY (SHENZHEN) CO. LTD., were founded in 2015 to provide our best service in EMC, Radio, Telecom and Safety consultation. Our laboratories are accredited and approved according to ISO/IEC 17025.

If you have any comments, please feel free to contact us at the following:

Shenzhen EMC/RF Lab:

Tel: +86-755-88696566

Fax: +86-755-88696577

Email: customerservice.sw@bureauveritas.com

Web Site: www.adt.com.tw

The address and road map of all our labs can be found in our web site also.



Test Report No.: W7L-P22010007RF02

6 MODIFICATIONS RECORDERS FOR ENGINEERING CHANGES TO THE EUT BY THE LAB

No any modifications are made to the EUT by the lab during the test.

Please Refer to Appendix Of this test report.



**BUREAU
VERITAS**

Test Report No.: W7L-P22010007RF02

7 APPENDIX

WCDMA BAND5

PEAK-TO-AVERAGE RATIO

Test Result

Band	Channel	Peak-to-Average Ratio(dB)	Limit(dBm)	Verdict
Band5	4132	3.11	13	PASS
Band5	4182	3.19	13	PASS
Band5	4233	3.15	13	PASS



BUREAU
VERITAS

Test Report No.: W7L-P22010007RF02

Test Graphs





**BUREAU
VERITAS**

Test Report No.: W7L-P22010007RF02



26DB BANDWIDTH AND OCCUPIED BANDWIDTH

Test Result

Band	Channel	Occupied Bandwidth (MHz)	26dB Bandwidth (MHz)	Limit(MHz)	Verdict
Band5	4132	4.1589	4.740	---	PASS
Band5	4182	4.1628	4.742	---	PASS
Band5	4233	4.1558	4.741	---	PASS

Test Graphs

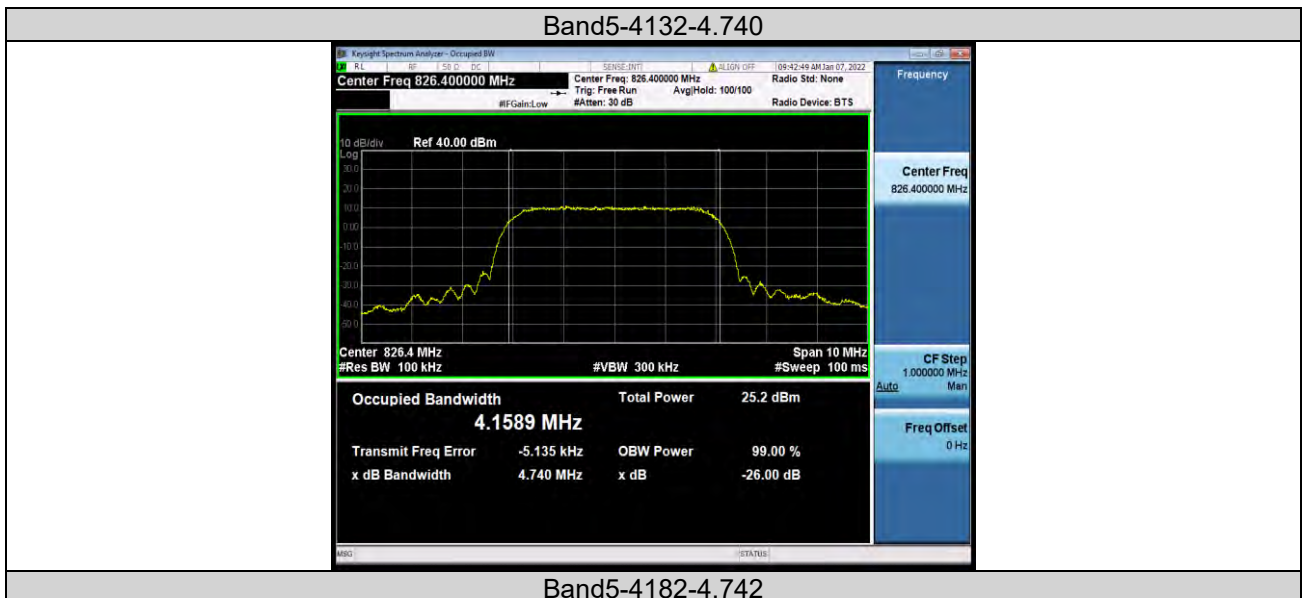

Band5-4182-4.742



BUREAU VERITAS

Test Report No.: W7L-P22010007RF02

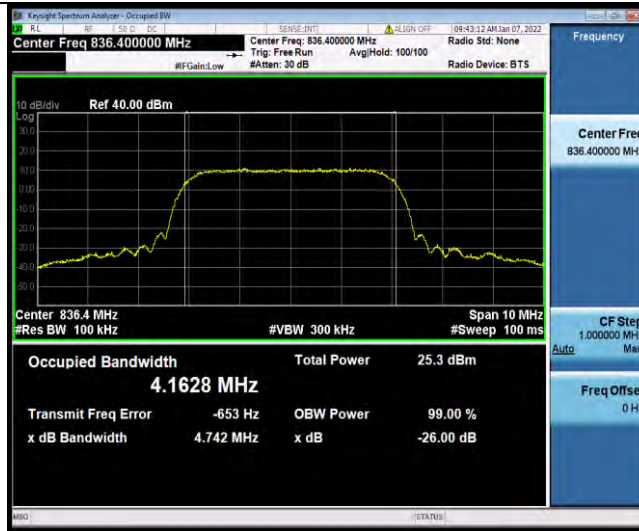

Band5-4233-4.741

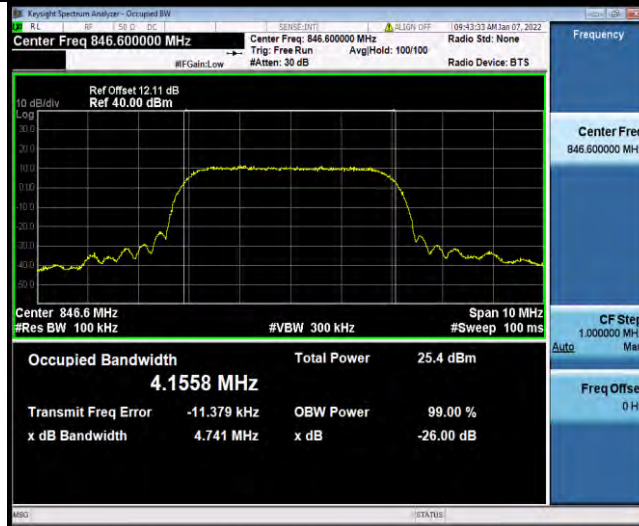



**BUREAU
VERITAS**

Test Report No.: W7L-P22010007RF02

BAND EDGE

Test Result

Band	Channel	Frequency (MHz)	Result (dBm)	Limit(dBm)	Verdict
Band5	4132	824.00	-27.74	-13	PASS
Band5	4233	849.00	-26.83	-13	PASS

Test Graphs





CONDUCTED SPURIOUS EMISSION

Test Result

Band	Channel	Frequency Range (Mhz)	Frequency (dBm)	Result (dBm)	Limit (dBm)	Verdict
Band5	4132	30~1000MHz	932.55	-48.25	-13	PASS
Band5	4132	1000~10000MHz	3770.5	-34.73	-13	PASS
Band5	4182	30~1000MHz	603.27	-48.7	-13	PASS
Band5	4182	1000~10000MHz	3797.5	-34.7	-13	PASS
Band5	4233	30~1000MHz	983.03	-48.41	-13	PASS
Band5	4233	1000~10000MHz	3760.3	-34.74	-13	PASS

Test Graphs

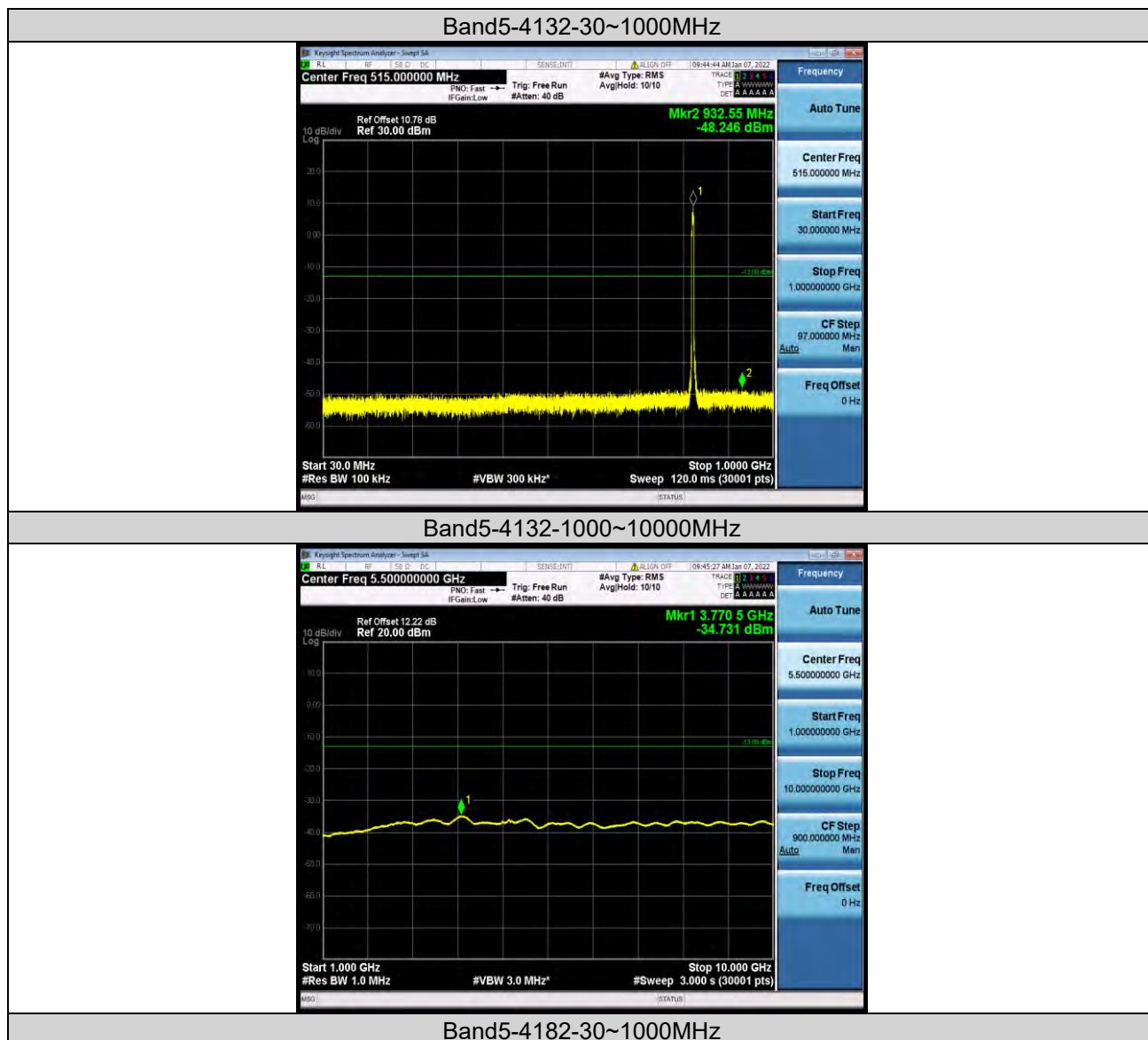



BUREAU VERITAS

Test Report No.: W7L-P22010007RF02

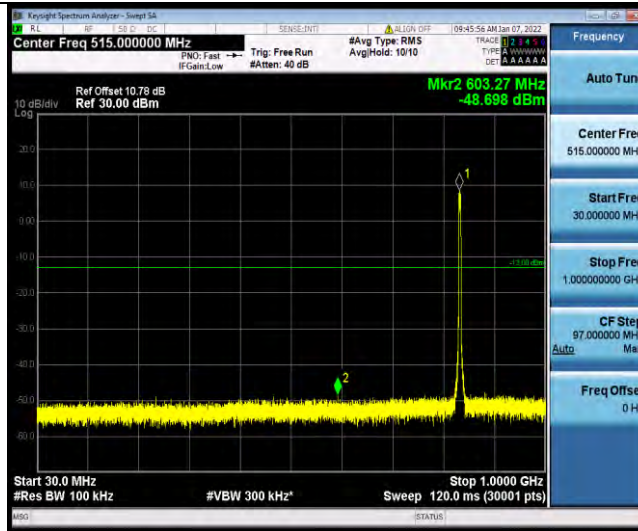

Band5-4182-1000~10000MHz



Band5-4233-30~10000MHz

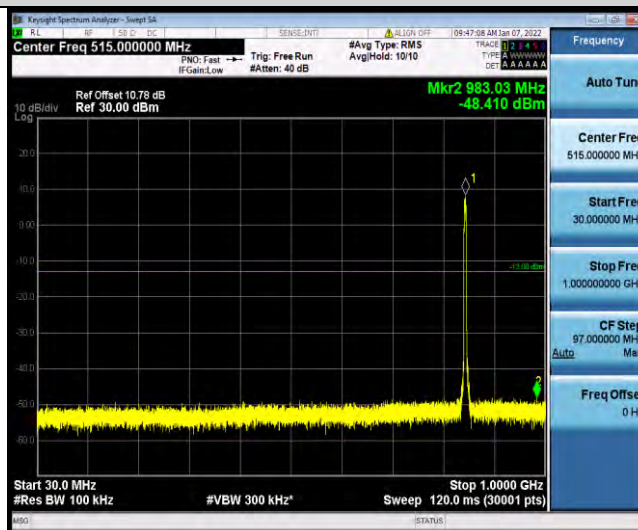

Band5-4233-1000~10000MHz



BUREAU
VERITAS

Test Report No.: W7L-P22010007RF02





FREQUENCY STABILITY

Test Result

Voltage							
Band	Channel	Voltage (Vdc)	Temperature (°C)	Deviation (Hz)	Deviation (ppm)	Limit (ppm)	Verdict
Band5	4132	VL	NT	-2.52	-0.003049	±2.5	PASS
Band5	4132	VN	NT	-2.42	-0.002928	±2.5	PASS
Band5	4132	VH	NT	-2.20	-0.002662	±2.5	PASS
Band5	4182	VL	NT	-0.30	-0.000359	±2.5	PASS
Band5	4182	VN	NT	-0.21	-0.000251	±2.5	PASS
Band5	4182	VH	NT	-0.36	-0.000430	±2.5	PASS
Band5	4233	VL	NT	0.31	0.000366	±2.5	PASS
Band5	4233	VN	NT	0.43	0.000508	±2.5	PASS
Band5	4233	VH	NT	0.26	0.000307	±2.5	PASS

Temperature							
Band	Channel	Voltage (Vdc)	Temperature (°C)	Deviation (Hz)	Deviation (ppm)	Limit (ppm)	Verdict
Band5	4132	NV	-30	-2.15	-0.002602	±2.5	PASS
Band5	4132	NV	-20	-2.10	-0.002541	±2.5	PASS
Band5	4132	NV	0	-2.00	-0.002420	±2.5	PASS
Band5	4132	NV	10	-1.80	-0.002178	±2.5	PASS
Band5	4132	NV	20	-1.84	-0.002227	±2.5	PASS
Band5	4132	NV	30	-1.66	-0.002009	±2.5	PASS
Band5	4132	NV	40	-1.60	-0.001936	±2.5	PASS
Band5	4132	NV	50	-1.60	-0.001936	±2.5	PASS
Band5	4182	NV	-30	-0.33	-0.000395	±2.5	PASS
Band5	4182	NV	-20	-0.11	-0.000132	±2.5	PASS
Band5	4182	NV	0	-0.30	-0.000359	±2.5	PASS
Band5	4182	NV	10	-0.10	-0.000120	±2.5	PASS
Band5	4182	NV	20	-0.20	-0.000239	±2.5	PASS
Band5	4182	NV	30	-0.04	-0.000048	±2.5	PASS
Band5	4182	NV	40	-0.19	-0.000227	±2.5	PASS
Band5	4182	NV	50	-0.04	-0.000048	±2.5	PASS
Band5	4233	NV	-30	0.40	0.000472	±2.5	PASS
Band5	4233	NV	-20	0.24	0.000283	±2.5	PASS
Band5	4233	NV	0	0.29	0.000343	±2.5	PASS
Band5	4233	NV	10	0.40	0.000472	±2.5	PASS
Band5	4233	NV	20	0.27	0.000319	±2.5	PASS
Band5	4233	NV	30	0.31	0.000366	±2.5	PASS
Band5	4233	NV	40	0.33	0.000390	±2.5	PASS
Band5	4233	NV	50	0.26	0.000307	±2.5	PASS



LTE BAND5

PEAK-TO-AVERAGE RATIO (CCDF)

Test Result

Band	Bandwidth	Modulation	Channel	RB Configuration	Result(dB)	Limit(dB)	Verdict
Band5	1.4MHz	QPSK	20407	1RB#0	4.24	13	PASS
Band5	1.4MHz	QPSK	20407	6RB#0	4.84	13	PASS
Band5	1.4MHz	QPSK	20525	1RB#0	4.35	13	PASS
Band5	1.4MHz	QPSK	20525	6RB#0	4.95	13	PASS
Band5	1.4MHz	QPSK	20643	1RB#0	4.17	13	PASS
Band5	1.4MHz	QPSK	20643	6RB#0	4.78	13	PASS
Band5	1.4MHz	16QAM	20407	1RB#0	5.13	13	PASS
Band5	1.4MHz	16QAM	20407	6RB#0	5.61	13	PASS
Band5	1.4MHz	16QAM	20525	1RB#0	5.14	13	PASS
Band5	1.4MHz	16QAM	20525	6RB#0	5.78	13	PASS
Band5	1.4MHz	16QAM	20643	1RB#0	5.06	13	PASS
Band5	1.4MHz	16QAM	20643	6RB#0	5.58	13	PASS
Band5	3MHz	QPSK	20415	1RB#0	4.19	13	PASS
Band5	3MHz	QPSK	20415	15RB#0	4.91	13	PASS
Band5	3MHz	QPSK	20525	1RB#0	4.32	13	PASS
Band5	3MHz	QPSK	20525	15RB#0	5.02	13	PASS
Band5	3MHz	QPSK	20635	1RB#0	4.19	13	PASS
Band5	3MHz	QPSK	20635	15RB#0	4.88	13	PASS
Band5	3MHz	16QAM	20415	1RB#0	5.07	13	PASS
Band5	3MHz	16QAM	20415	15RB#0	5.74	13	PASS
Band5	3MHz	16QAM	20525	1RB#0	5.18	13	PASS
Band5	3MHz	16QAM	20525	15RB#0	5.84	13	PASS
Band5	3MHz	16QAM	20635	1RB#0	5.05	13	PASS
Band5	3MHz	16QAM	20635	15RB#0	5.73	13	PASS
Band5	5MHz	QPSK	20425	1RB#0	4.18	13	PASS
Band5	5MHz	QPSK	20425	25RB#0	4.95	13	PASS
Band5	5MHz	QPSK	20525	1RB#0	4.27	13	PASS
Band5	5MHz	QPSK	20525	25RB#0	5.08	13	PASS
Band5	5MHz	QPSK	20625	1RB#0	4.19	13	PASS
Band5	5MHz	QPSK	20625	25RB#0	4.89	13	PASS
Band5	5MHz	16QAM	20425	1RB#0	4.88	13	PASS
Band5	5MHz	16QAM	20425	25RB#0	5.72	13	PASS
Band5	5MHz	16QAM	20525	1RB#0	5.17	13	PASS
Band5	5MHz	16QAM	20525	25RB#0	5.80	13	PASS
Band5	5MHz	16QAM	20625	1RB#0	4.83	13	PASS
Band5	5MHz	16QAM	20625	25RB#0	5.71	13	PASS
Band5	10MHz	QPSK	20450	1RB#0	4.14	13	PASS
Band5	10MHz	QPSK	20450	50RB#0	4.96	13	PASS
Band5	10MHz	QPSK	20525	1RB#0	4.19	13	PASS
Band5	10MHz	QPSK	20525	50RB#0	5.10	13	PASS
Band5	10MHz	QPSK	20600	1RB#0	4.25	13	PASS
Band5	10MHz	QPSK	20600	50RB#0	4.90	13	PASS



BUREAU
VERITAS

Test Report No.: W7L-P22010007RF02

Band5	10MHz	16QAM	20450	1RB#0	5.05	13	PASS
Band5	10MHz	16QAM	20450	50RB#0	5.75	13	PASS
Band5	10MHz	16QAM	20525	1RB#0	4.96	13	PASS
Band5	10MHz	16QAM	20525	50RB#0	5.85	13	PASS
Band5	10MHz	16QAM	20600	1RB#0	5.16	13	PASS
Band5	10MHz	16QAM	20600	50RB#0	5.72	13	PASS



BUREAU
VERITAS

Test Report No.: W7L-P22010007RF02

Test Graphs

Band5-1.4MHz-QPSK-20407-1RB#0

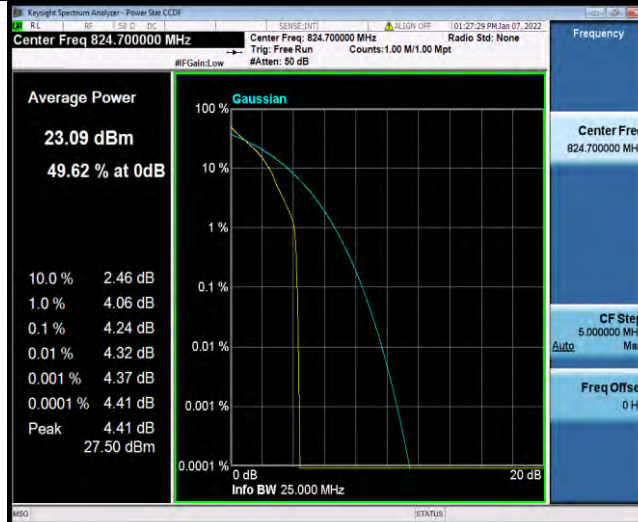

Band5-1.4MHz-QPSK-20407-6RB#0



Band5-1.4MHz-QPSK-20525-1RB#0



BUREAU VERITAS

Test Report No.: W7L-P22010007RF02

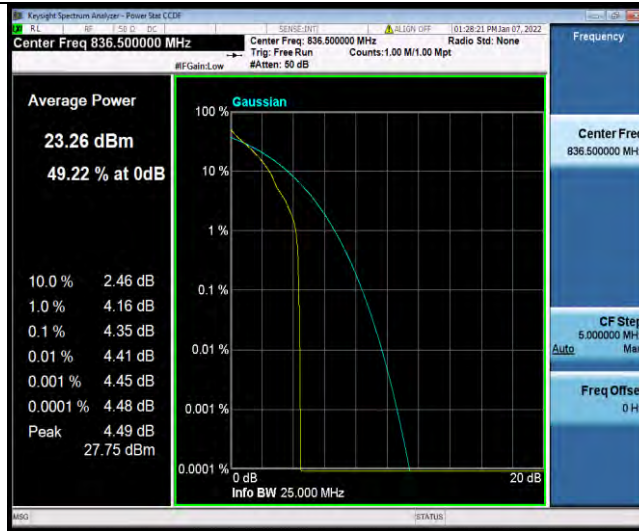

Band5-1.4MHz-QPSK-20525-6RB#0

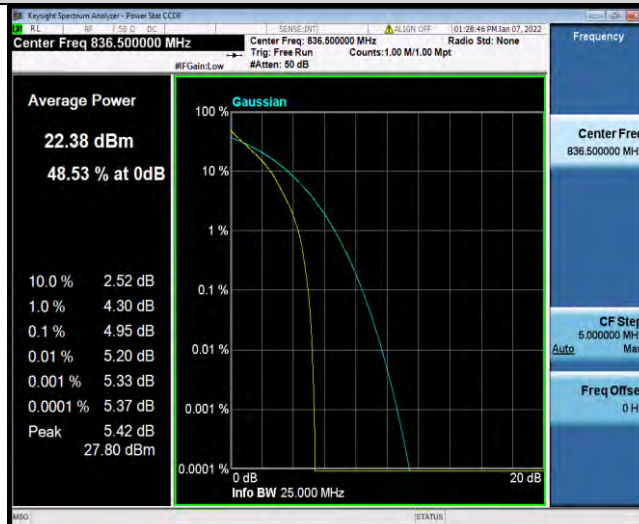

Band5-1.4MHz-QPSK-20643-1RB#0



Band5-1.4MHz-QPSK-20643-6RB#0



BUREAU VERITAS

Test Report No.: W7L-P22010007RF02



Band5-1.4MHz-16QAM-20407-1RB#0

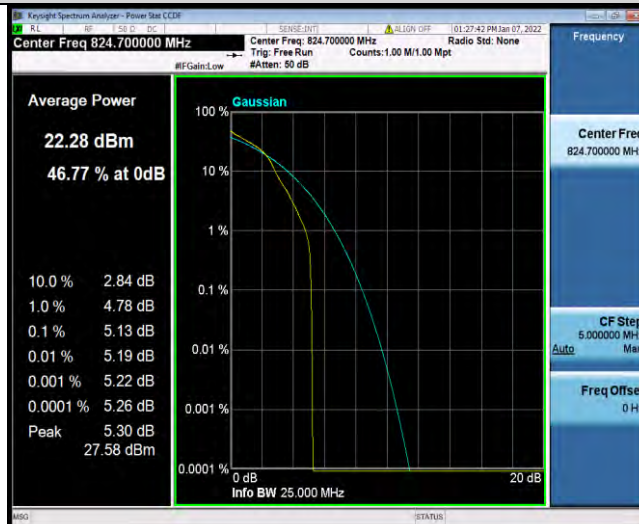

Band5-1.4MHz-16QAM-20407-6RB#0

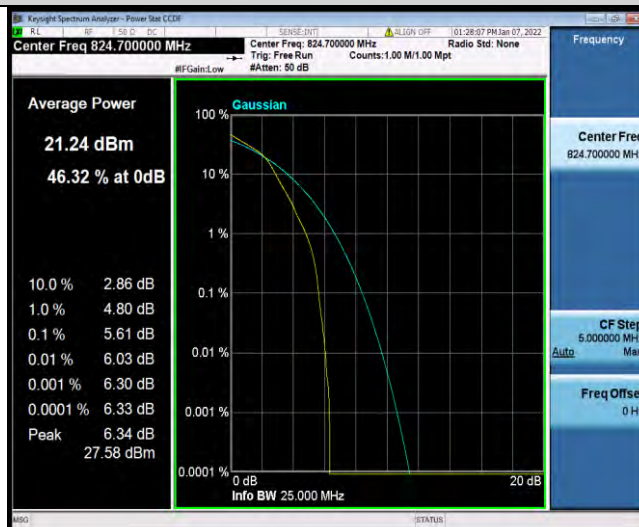

Band5-1.4MHz-16QAM-20525-1RB#0



BUREAU
VERITAS

Test Report No.: W7L-P22010007RF02

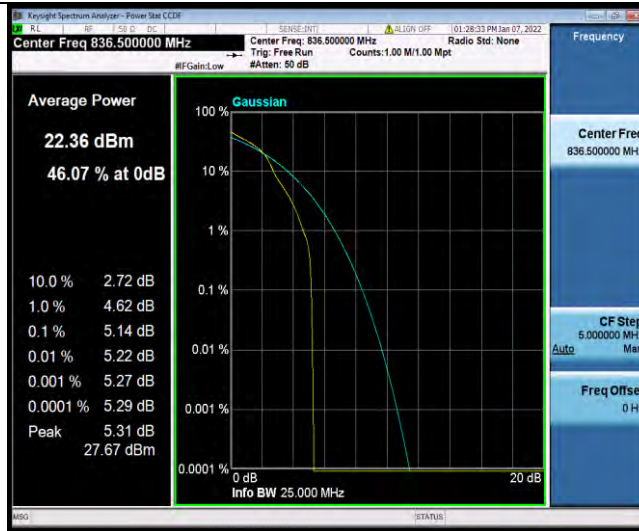

Band5-1.4MHz-16QAM-20525-6RB#0

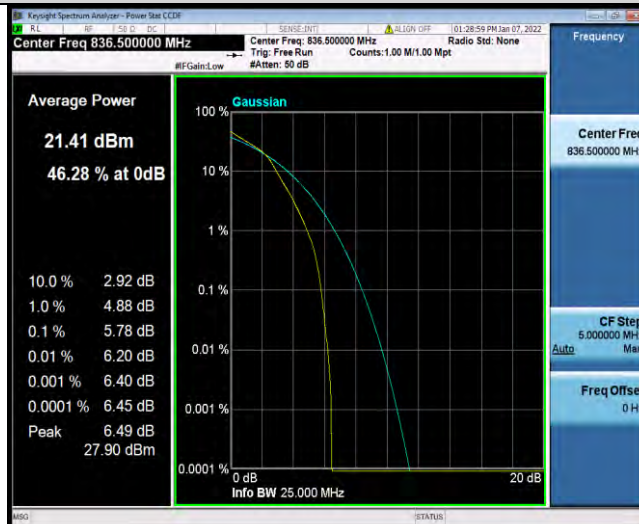

Band5-1.4MHz-16QAM-20643-1RB#0



Band5-1.4MHz-16QAM-20643-6RB#0



BUREAU VERITAS

Test Report No.: W7L-P22010007RF02

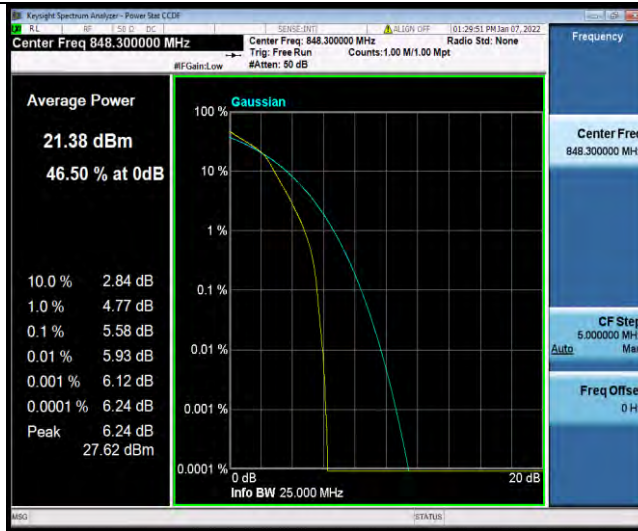

Band5-3MHz-QPSK-20415-1RB#0

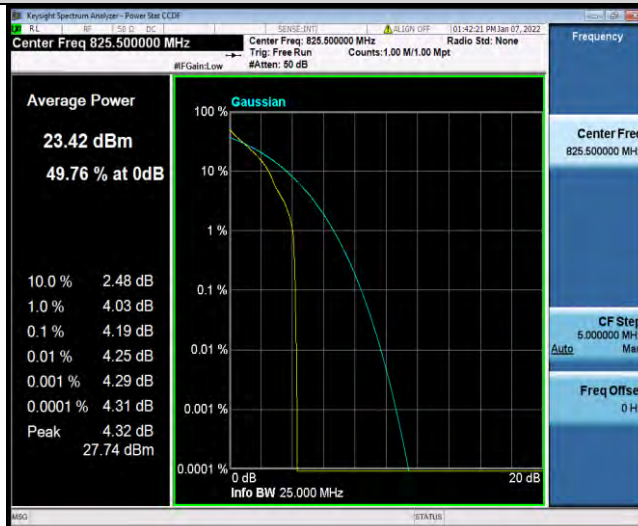

Band5-3MHz-QPSK-20415-15RB#0



Band5-3MHz-QPSK-20525-1RB#0



BUREAU VERITAS

Test Report No.: W7L-P22010007RF02



Band5-3MHz-QPSK-20525-15RB#0

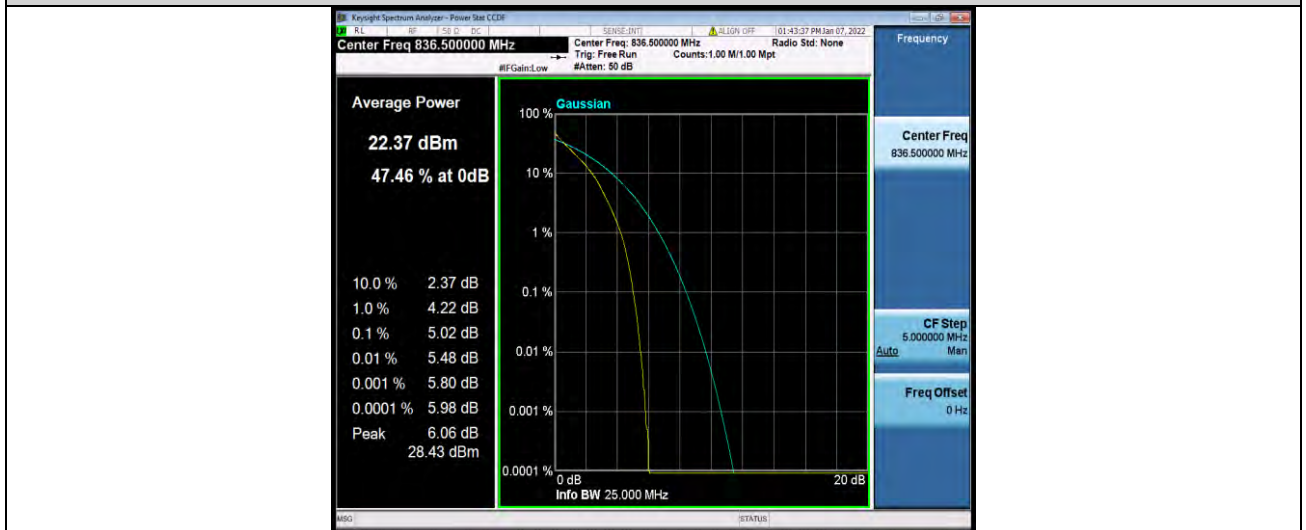

Band5-3MHz-QPSK-20635-1RB#0



Band5-3MHz-QPSK-20635-15RB#0



BUREAU VERITAS

Test Report No.: W7L-P22010007RF02

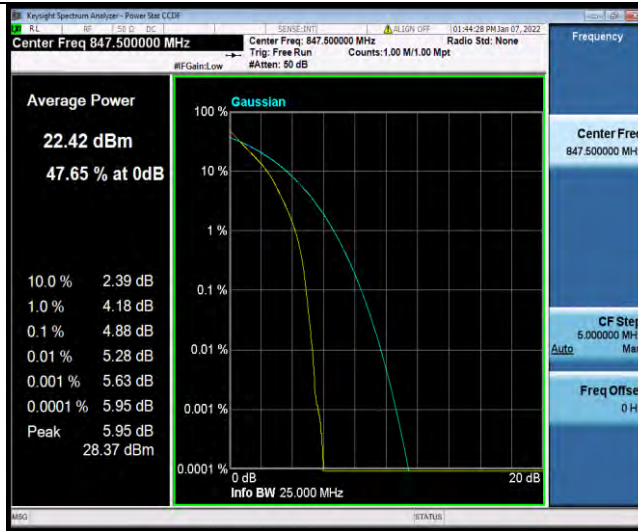

Band5-3MHz-16QAM-20415-1RB#0

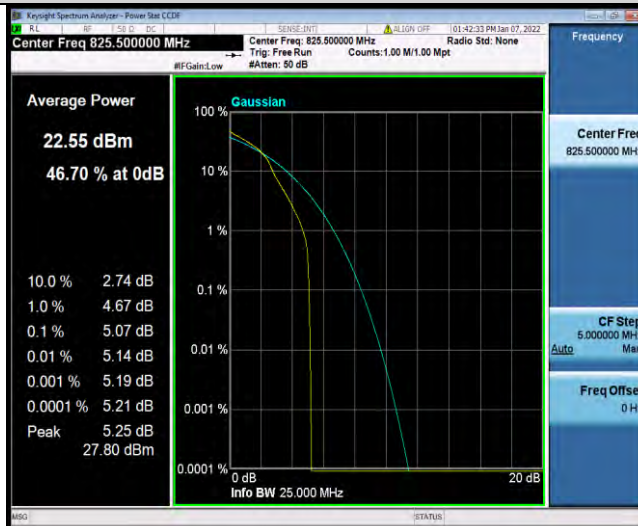

Band5-3MHz-16QAM-20415-15RB#0

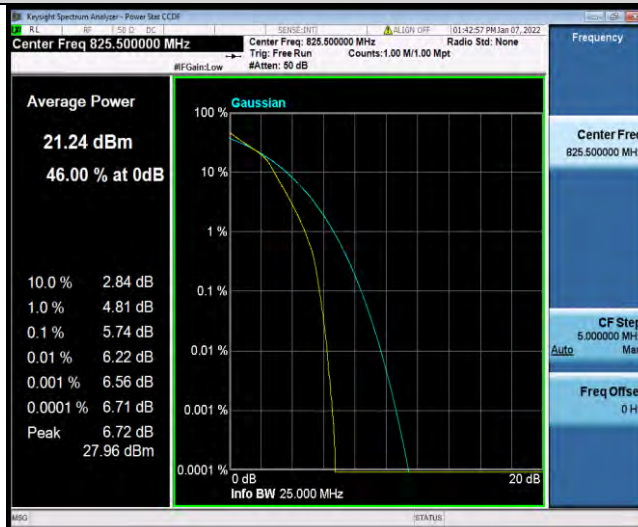

Band5-3MHz-16QAM-20525-1RB#0



BUREAU VERITAS

Test Report No.: W7L-P22010007RF02



Band5-3MHz-16QAM-20525-15RB#0

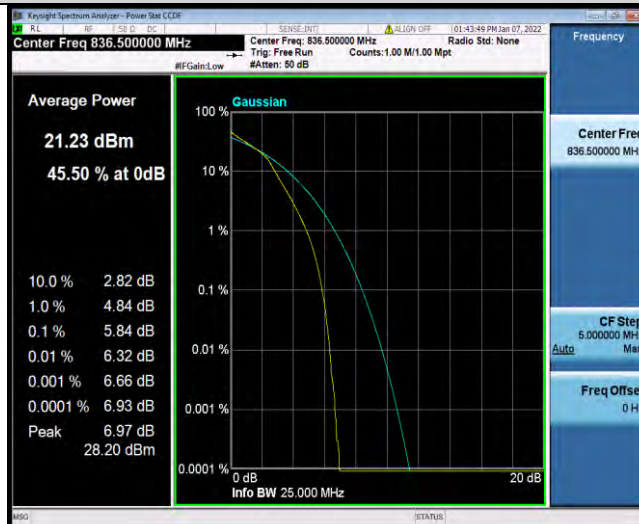

Band5-3MHz-16QAM-20635-1RB#0

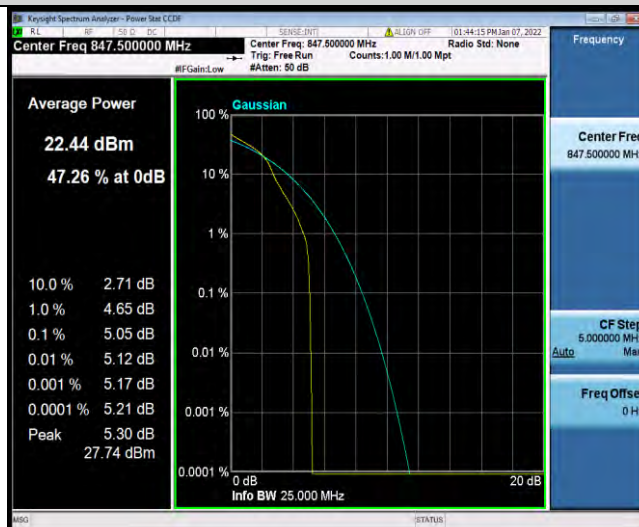

Band5-3MHz-16QAM-20635-15RB#0



BUREAU VERITAS

Test Report No.: W7L-P22010007RF02



Band5-5MHz-QPSK-20425-1RB#0

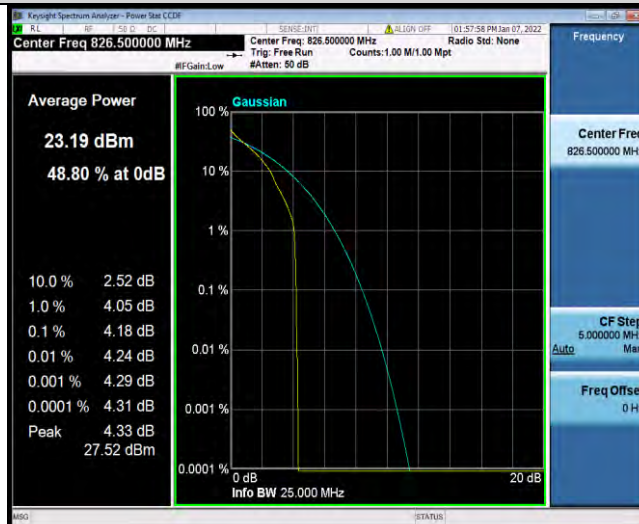

Band5-5MHz-QPSK-20425-25RB#0



Band5-5MHz-QPSK-20525-1RB#0



BUREAU VERITAS

Test Report No.: W7L-P22010007RF02

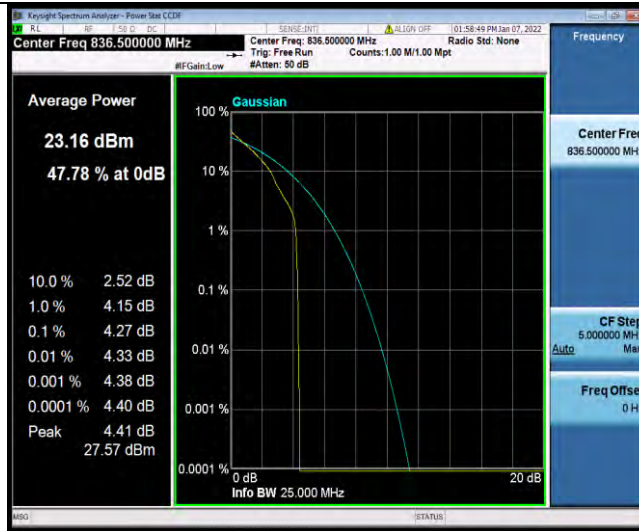

Band5-5MHz-QPSK-20525-25RB#0



Band5-5MHz-QPSK-20625-1RB#0



Band5-5MHz-QPSK-20625-25RB#0



BUREAU VERITAS

Test Report No.: W7L-P22010007RF02

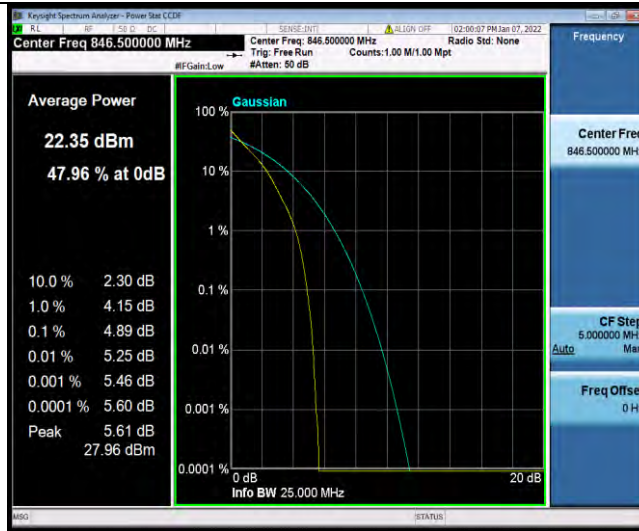

Band5-5MHz-16QAM-20425-1RB#0

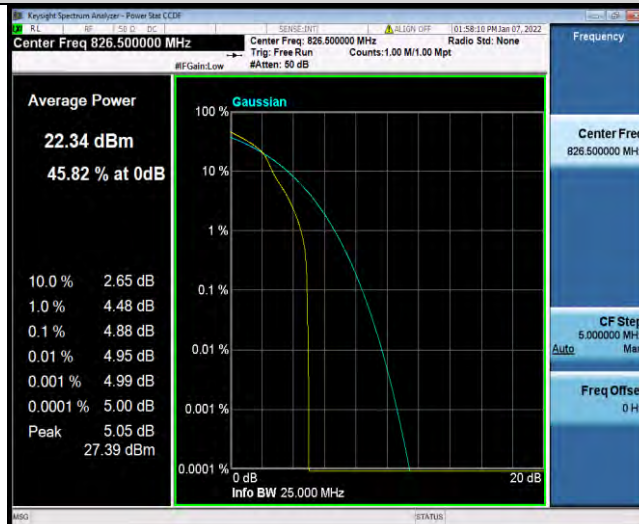

Band5-5MHz-16QAM-20425-25RB#0

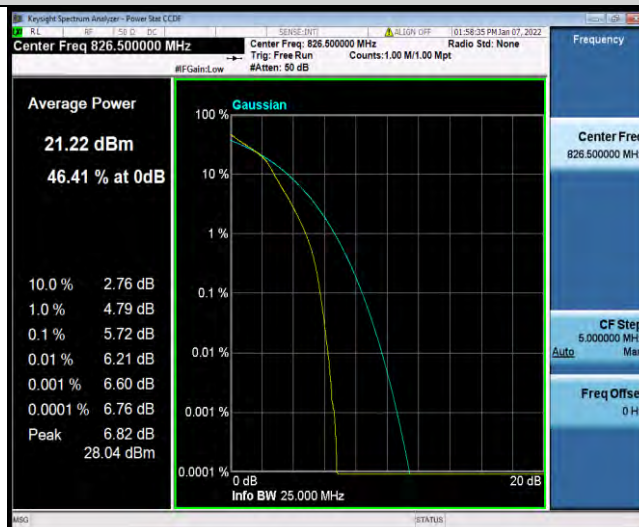

Band5-5MHz-16QAM-20525-1RB#0



BUREAU VERITAS

Test Report No.: W7L-P22010007RF02



Band5-5MHz-16QAM-20525-25RB#0



Band5-5MHz-16QAM-20625-1RB#0



Band5-5MHz-16QAM-20625-25RB#0



BUREAU VERITAS

Test Report No.: W7L-P22010007RF02



Band5-10MHz-QPSK-20450-1RB#0



Band5-10MHz-QPSK-20450-50RB#0

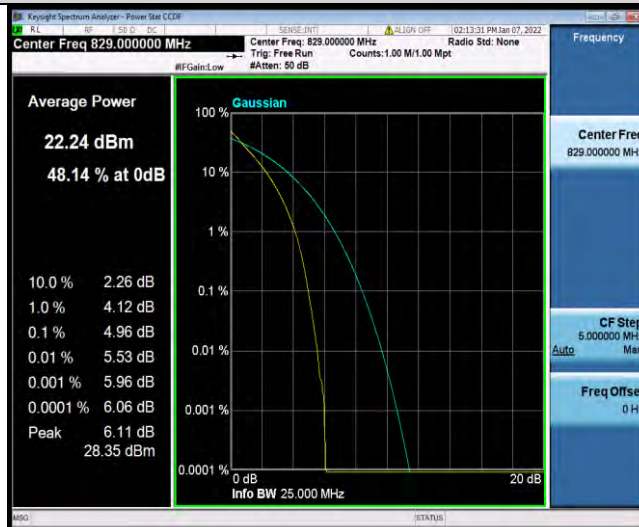

Band5-10MHz-QPSK-20525-1RB#0



BUREAU VERITAS

Test Report No.: W7L-P22010007RF02



Band5-10MHz-QPSK-20525-50RB#0

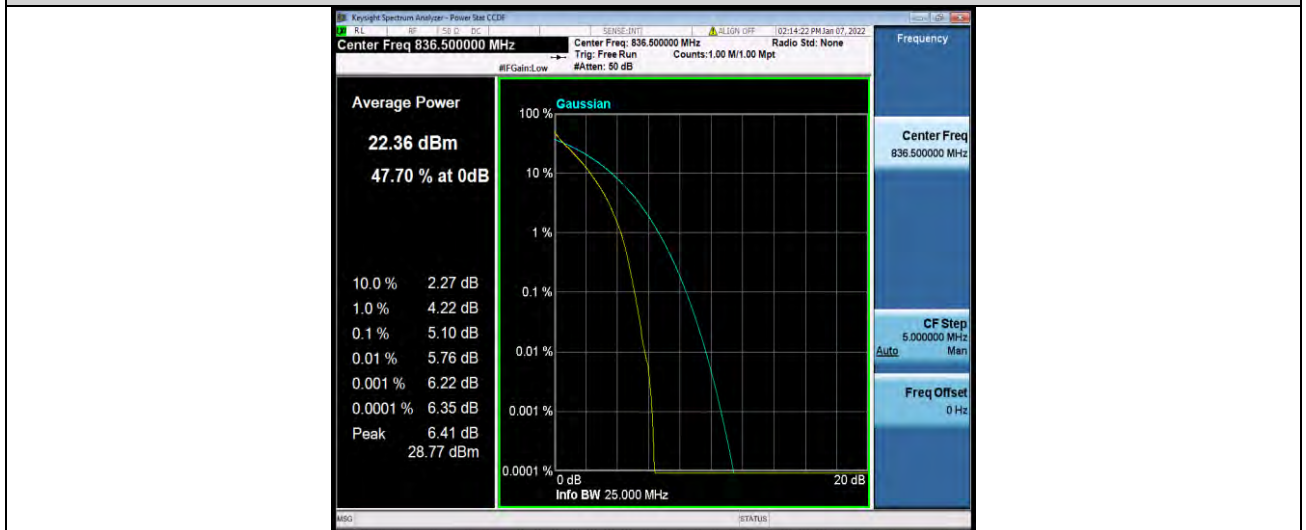

Band5-10MHz-QPSK-20600-1RB#0

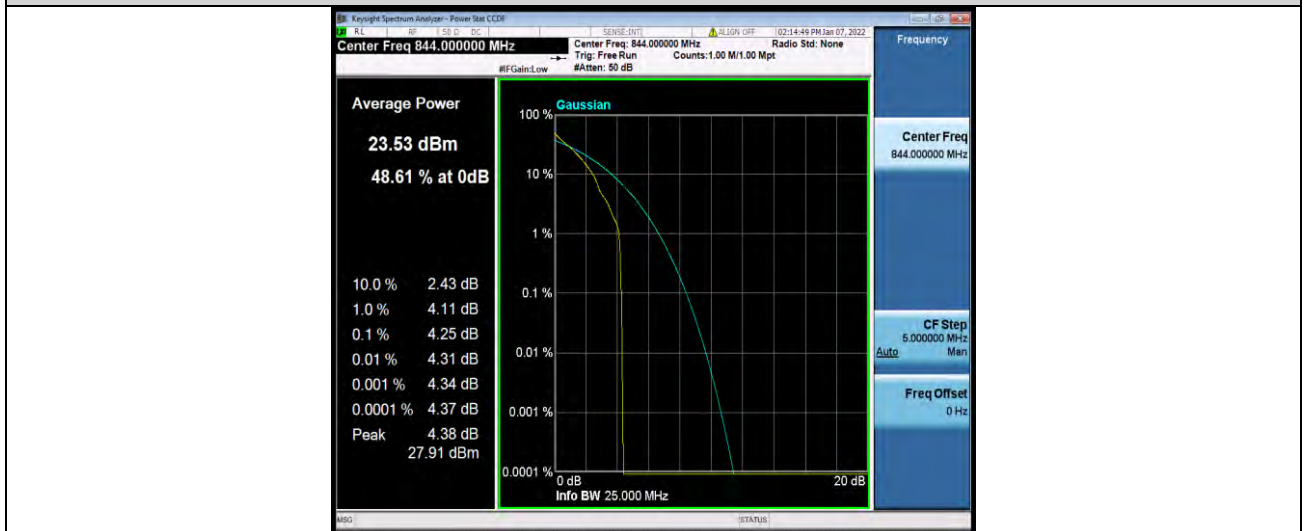

Band5-10MHz-QPSK-20600-50RB#0



BUREAU VERITAS

Test Report No.: W7L-P22010007RF02

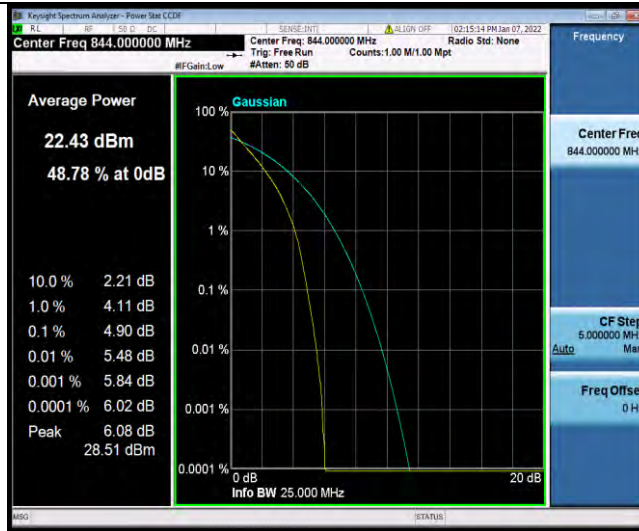

Band5-10MHz-16QAM-20450-1RB#0



Band5-10MHz-16QAM-20450-50RB#0

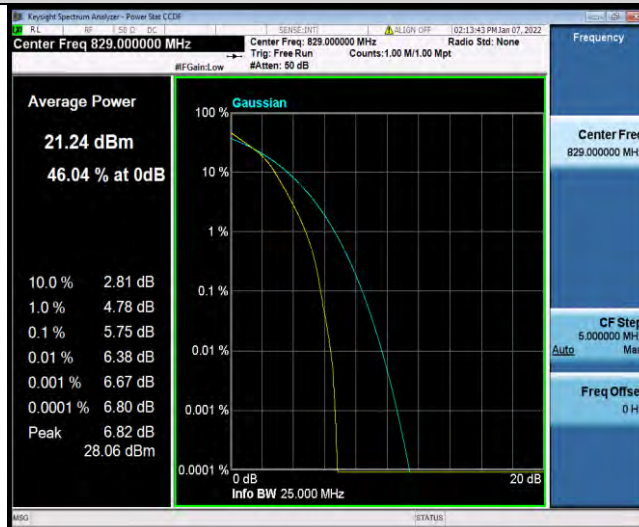

Band5-10MHz-16QAM-20525-1RB#0



BUREAU VERITAS

Test Report No.: W7L-P22010007RF02



Band5-10MHz-16QAM-20525-50RB#0

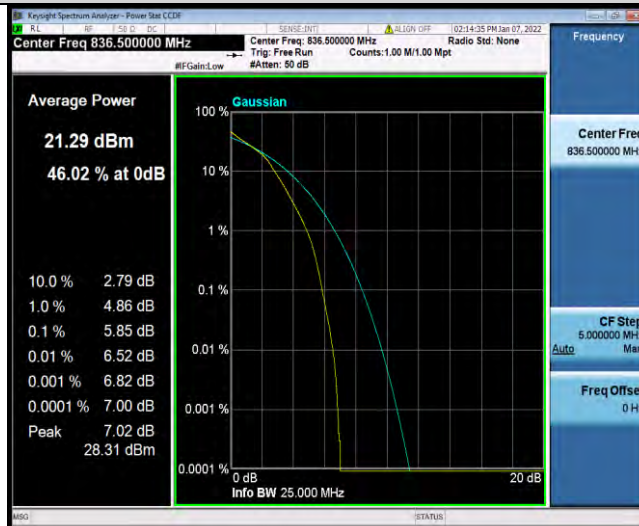

Band5-10MHz-16QAM-20600-1RB#0

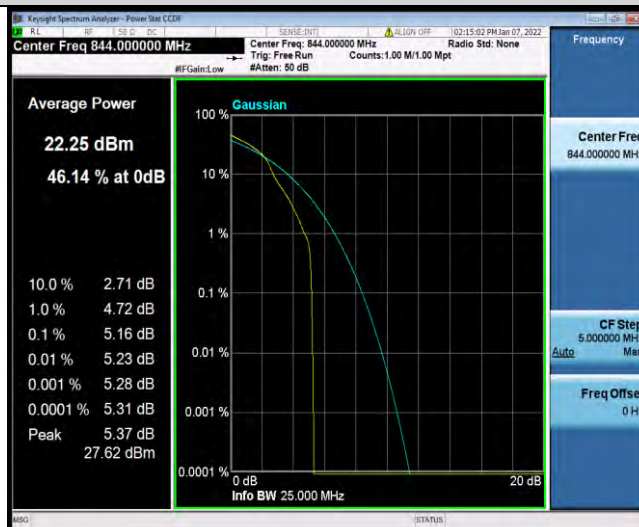

Band5-10MHz-16QAM-20600-50RB#0



BUREAU
VERITAS

Test Report No.: W7L-P22010007RF02

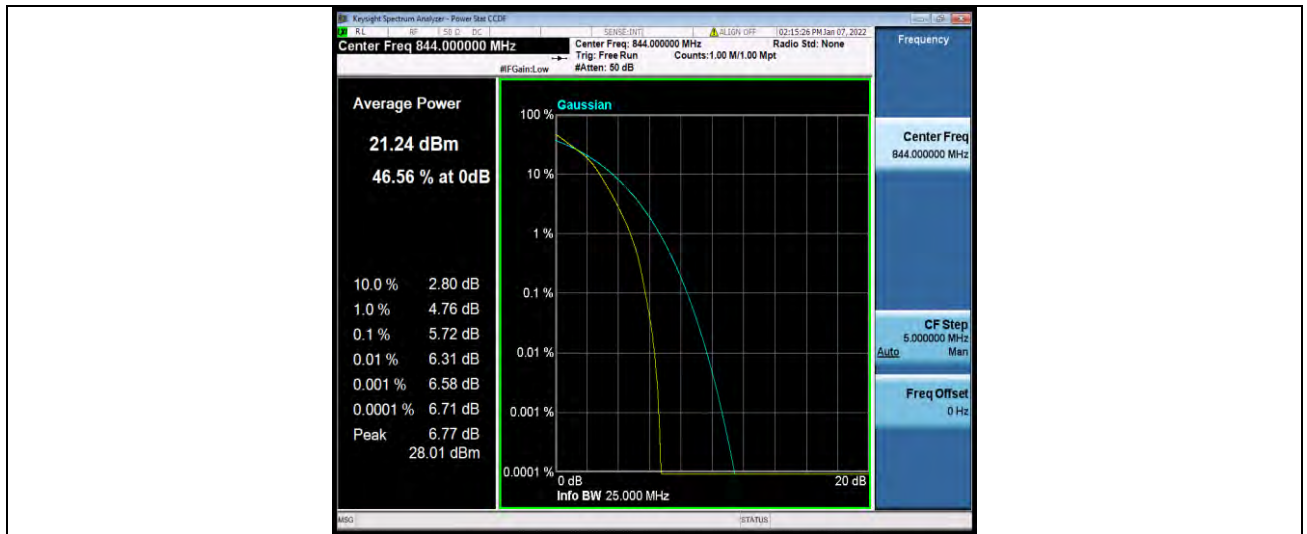



26DB BANDWIDTH AND OCCUPIED BANDWIDTH

Test Result

Band	Bandwidth	Modulation	Channel	RB Configuration	Occupied Bandwidth (MHz)	26dB Bandwidth (MHz)	Verdict
Band5	1.4MHz	QPSK	20407	6RB#0	1.0906	1.258	PASS
Band5	1.4MHz	QPSK	20525	6RB#0	1.0910	1.266	PASS
Band5	1.4MHz	QPSK	20643	6RB#0	1.0936	1.272	PASS
Band5	1.4MHz	16QAM	20407	6RB#0	1.0924	1.262	PASS
Band5	1.4MHz	16QAM	20525	6RB#0	1.0890	1.242	PASS
Band5	1.4MHz	16QAM	20643	6RB#0	1.0915	1.271	PASS
Band5	3MHz	QPSK	20415	15RB#0	2.6894	2.914	PASS
Band5	3MHz	QPSK	20525	15RB#0	2.7015	2.918	PASS
Band5	3MHz	QPSK	20635	15RB#0	2.6982	2.922	PASS
Band5	3MHz	16QAM	20415	15RB#0	2.6894	2.926	PASS
Band5	3MHz	16QAM	20525	15RB#0	2.6961	2.926	PASS
Band5	3MHz	16QAM	20635	15RB#0	2.6956	2.913	PASS
Band5	5MHz	QPSK	20425	25RB#0	4.5062	4.902	PASS
Band5	5MHz	QPSK	20525	25RB#0	4.5078	4.894	PASS
Band5	5MHz	QPSK	20625	25RB#0	4.5089	4.837	PASS
Band5	5MHz	16QAM	20425	25RB#0	4.5070	4.924	PASS
Band5	5MHz	16QAM	20525	25RB#0	4.5063	4.921	PASS
Band5	5MHz	16QAM	20625	25RB#0	4.5119	4.876	PASS
Band5	10MHz	QPSK	20450	50RB#0	8.9734	9.556	PASS
Band5	10MHz	QPSK	20525	50RB#0	8.9866	9.561	PASS
Band5	10MHz	QPSK	20600	50RB#0	8.9505	9.522	PASS
Band5	10MHz	16QAM	20450	50RB#0	8.9594	9.537	PASS
Band5	10MHz	16QAM	20525	50RB#0	8.9935	9.553	PASS
Band5	10MHz	16QAM	20600	50RB#0	8.9503	9.544	PASS



BUREAU
VERITAS

Test Report No.: W7L-P22010007RF02

Test Graphs





BUREAU VERITAS

Test Report No.: W7L-P22010007RF02

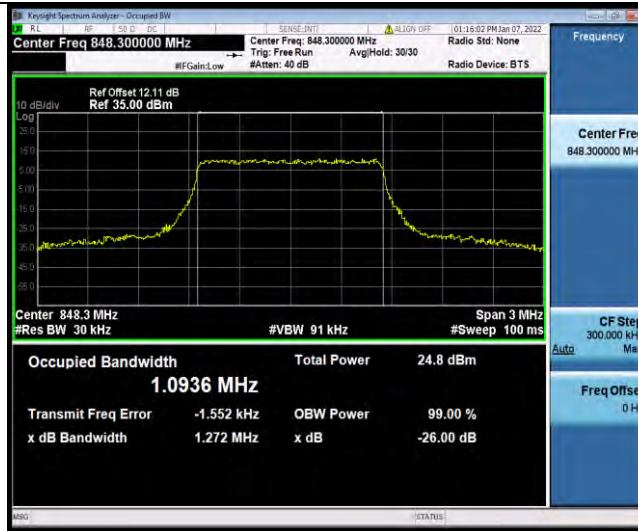

Band5-1.4MHz-16QAM-20407-6RB#0



Band5-1.4MHz-16QAM-20525-6RB#0



Band5-1.4MHz-16QAM-20643-6RB#0



BUREAU VERITAS

Test Report No.: W7L-P22010007RF02

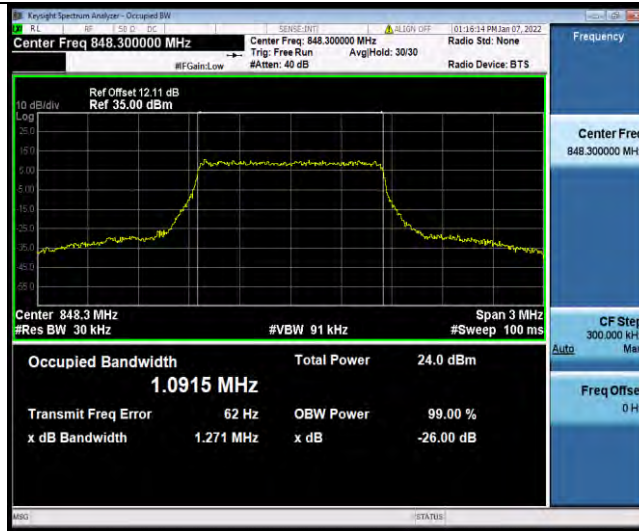

Band5-3MHz-QPSK-20415-15RB#0



Band5-3MHz-QPSK-20525-15RB#0

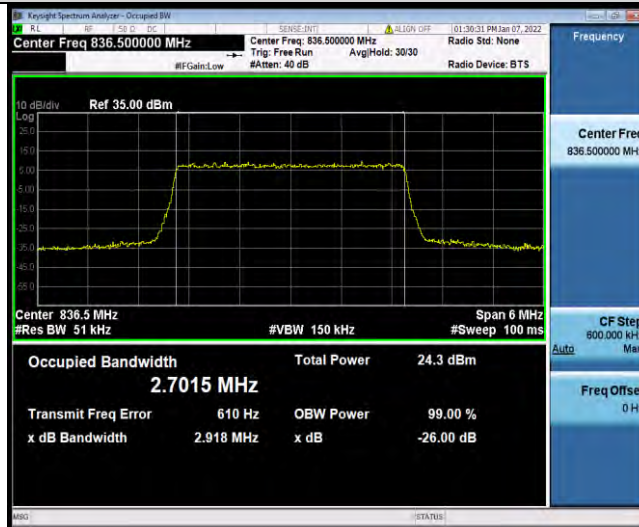

Band5-3MHz-QPSK-20635-15RB#0



BUREAU VERITAS

Test Report No.: W7L-P22010007RF02



Band5-3MHz-16QAM-20415-15RB#0



Band5-3MHz-16QAM-20525-15RB#0



Band5-3MHz-16QAM-20635-15RB#0



BUREAU VERITAS

Test Report No.: W7L-P22010007RF02

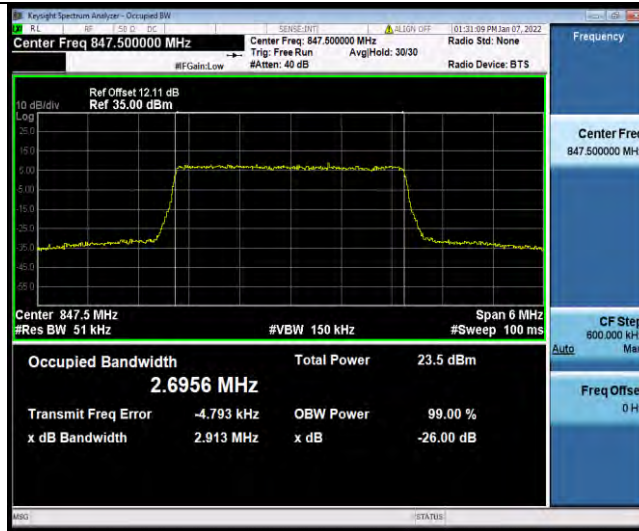

Band5-5MHz-QPSK-20425-25RB#0



Band5-5MHz-QPSK-20525-25RB#0



Band5-5MHz-QPSK-20625-25RB#0



BUREAU VERITAS

Test Report No.: W7L-P22010007RF02

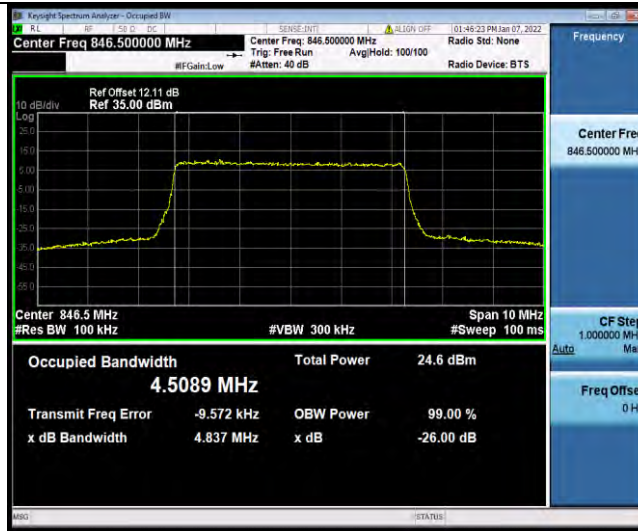

Band5-5MHz-16QAM-20425-25RB#0



Band5-5MHz-16QAM-20525-25RB#0



Band5-5MHz-16QAM-20625-25RB#0



BUREAU VERITAS

Test Report No.: W7L-P22010007RF02

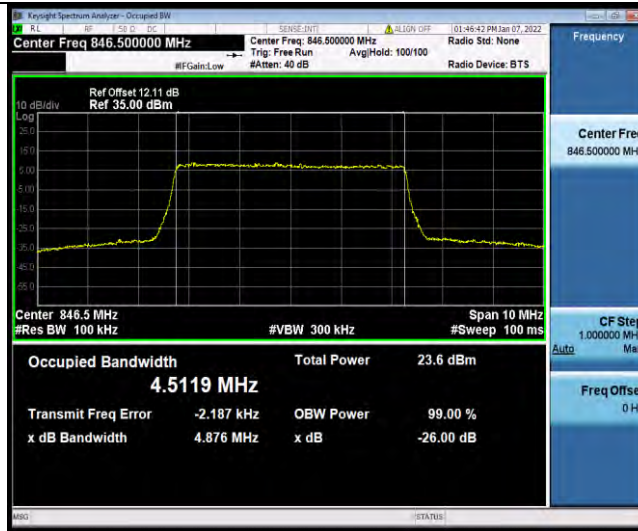

Band5-10MHz-QPSK-20450-50RB#0



Band5-10MHz-QPSK-20525-50RB#0



Band5-10MHz-QPSK-20600-50RB#0