



Test Report No.: W7L-P23050004-1RF03



FCC TEST REPORT

(Part 15, Subpart E)

Applicant:	PAX Technology Limited
Address:	Room 2416, 24/F., Sun Hung Kai Centre, 30 Harbour, Hong Kong China

Manufacturer or Supplier:	PAX Computer Technology (Shenzhen) Co., Ltd.
Address:	401 and 402, Building 3, Shenzhen Software Park, Nanshan District, Shenzhen City, Guangdong Province, P.R.C
Product:	Smart Desktop Terminal
Brand Name:	PAX
Model Name:	A8500P, A8500N
FCC ID:	V5PA8500
Date of tests:	May. 5, 2023 ~ Jun. 14, 2023

The tests have been carried out according to the requirements of the following standard:

FCC Part 15, Subpart E, Section 15.407

CONCLUSION: The submitted sample was found to COMPLY with the test requirement

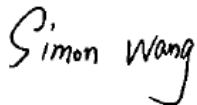
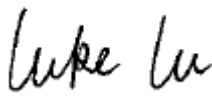
Prepared by Simon Wang Engineer / Mobile Department	Approved by Luke Lu Manager / Mobile Department
 Date: Jun. 14, 2023	 Date: Jun. 14, 2023

This report is governed by, and incorporates by reference, the Conditions of Testing as posted at the date of issuance of this report at <http://www.bureauveritas.com/home/about-us/our-business/cps/about-us/terms-conditions/> and is intended for your exclusive use. Any copying or replication of this report to or for any other person or entity, or use of our name or trademark, is permitted only with our prior written permission. This report sets forth our findings solely with respect to the test samples identified herein. The results set forth in this report are not indicative or representative of the quality or characteristics of the lot from which a test sample was taken or any similar or identical product unless specifically and expressly noted. Our report includes all of the tests requested by you and the results thereof based upon the information that you provided to us. Measurement uncertainty is only provided upon request for accredited tests. Statements of conformity are based on simple acceptance criteria without taking measurement uncertainty into account, unless otherwise requested in writing. You have 60 days from date of issuance of this report to notify us of any material error or omission caused by our negligence or if you require measurement uncertainty; provided, however, that such notice shall be in writing and shall specifically address the issue you wish to raise. A failure to raise such issue within the prescribed time shall constitute your unqualified acceptance of the completeness of this report, the tests conducted and the correctness of the report contents.



TABLE OF CONTENTS

RELEASE CONTROL RECORD	4
1 SUMMARY OF TEST RESULTS	5
1.1 MEASUREMENT UNCERTAINTY	6
2 GENERAL INFORMATION.....	7
2.1 GENERAL DESCRIPTION OF EUT	7
2.2 DESCRIPTION OF TEST MODES	11
2.2.1 TEST MODE APPLICABILITY AND TESTED CHANNEL DETAIL.....	14
2.3 DUTY CYCLE OF TEST SIGNAL	19
2.4 DESCRIPTION OF SUPPORT UNITS	19
2.4.1 CONFIGURATION OF SYSTEM UNDER TEST	20
2.5 GENERAL DESCRIPTION OF APPLIED STANDARDS	20
3 TEST TYPES AND RESULTS.....	21
3.1 RADIATED EMISSION AND BANDEDGE MEASUREMENT.....	21
3.1.1 LIMITS OF RADIATED EMISSION AND BANDEDGE MEASUREMENT.....	21
3.1.2 LIMITS OF UNWANTED EMISSION.....	21
3.1.3 TEST INSTRUMENTS.....	22
3.1.4 TEST PROCEDURES	23
3.1.5 DEVIATION FROM TEST STANDARD	23
3.1.6 TEST SETUP	24
3.1.7 EUT OPERATING CONDITION	25
3.1.8 TEST RESULTS	26
3.2 CONDUCTED EMISSION MEASUREMENT	109
3.2.1 LIMITS OF CONDUCTED EMISSION MEASUREMENT	109
3.2.2 TEST INSTRUMENTS.....	109
3.2.3 TEST PROCEDURES	109
3.2.4 DEVIATION FROM TEST STANDARD	110
3.2.5 TEST SETUP	110
3.2.6 EUT OPERATING CONDITIONS	110
3.2.7 TEST RESULTS	111
3.3 MAXIMUM CONDUCTED OUTPUT POWER MEASUREMENT	113
3.3.1 LIMITS OF MAXIMUM CONDUCTED OUTPUT POWER MEASUREMENT	113
3.3.2 TEST SETUP	114
3.3.3 TEST INSTRUMENTS.....	114



3.3.4	TEST PROCEDURE.....	115
3.3.5	DEVIATION FROM TEST STANDARD	117
3.3.6	EUT OPERATING CONDITIONS	117
3.3.7	TEST RESULTS	118
3.4	MAXIMUM POWER SPECTRAL DENSITY MEASUREMENT.....	119
3.4.1	LIMITS OF MAXIMUM POWER SPECTRAL DENSITY MEASUREMENT	119
3.4.2	TEST SETUP	119
3.4.3	TEST INSTRUMENTS.....	119
3.4.4	TEST PROCEDURES	120
3.4.5	DEVIATION FROM TEST STANDARD	120
3.4.6	EUT OPERATING CONDITIONS	120
3.4.7	TEST RESULTS	121
3.5	AUTOMATICALLY DISCONTINUE TRANSMISSION	122
3.5.1	LIMIT OF AUTOMATICALLY DISCONTINUE TRANSMISSION	122
3.5.2	TEST INSTRUMENTS.....	122
3.5.3	TEST RESULT	122
4	PHOTOGRAPHS OF THE TEST CONFIGURATION	123
5	MODIFICATIONS RECORDERS FOR ENGINEERING CHANGES TO THE EUT BY THE LAB124	
6	APPENDIX.....	125



BUREAU
VERITAS

Test Report No.: W7L-P23050004-1RF03

RELEASE CONTROL RECORD

ISSUE NO.	REASON FOR CHANGE	DATE ISSUED
W7L-P23050004-1RF03	Original release	Jun. 14, 2023



1 SUMMARY OF TEST RESULTS

The EUT has been tested according to the following specifications:

APPLIED STANDARD: FCC PART 15, SUBPART E		
STANDARD SECTION	TEST TYPE AND LIMIT	RESULT
15.407(b)(9)	AC Power Conducted Emission	Compliance
15.407(b) (1/2/3/4/5)	Radiated Emission & Band Edge Measurement	Compliance
15.407(a/1/2/3)	Maximum conducted output Power	Compliance
15.407(a/1/2/3)	Peak Power Spectral Density	Compliance
15.403(i)	26 dB Bandwidth	Compliance
15.407(e)	6 dB Bandwidth	Compliance
15.203	Antenna Requirement	Compliance

NOTE:

1. Except the data of RSE, other data of 802.11a & 802.11n/ac (20/40) & 802.11ac 80 please refer to the appendix.
2. Only the worse data were reported.
3. This report refers to the data of W7L-P23050004RF01 (FCC ID: V5PA85004G), the difference of (FCC ID: V5PA85004G) and (FCC ID: V5PA8500) is changing FCC ID and (FCC ID: V5PA8500) remove WWAN components (Modules & Antennas). This report verify power and RSE worse case. The result of power is similar and lower. So this report only update RSE worse case (11ac80 CH58) .



1.1 MEASUREMENT UNCERTAINTY

Where relevant, the following measurement uncertainty levels have been estimated for tests performed on the EUT as specified in CISPR 16-4-2:

MEASUREMENT	UNCERTAINTY
AC Power Conducted emissions	±2.70dB
Radiated emissions (9KHz~30MHz)	±2.68dB
Radiated emissions (30MHz~1GHz)	±4.98dB
Radiated emissions (1GHz ~6GHz)	±4.70dB
Radiated emissions (6GHz ~18GHz)	±4.60dB
Radiated emissions (18GHz ~40GHz)	±4.12dB
Conducted emissions	±4.01dB
Occupied Channel Bandwidth	±43.58KHz
Conducted Output power	±2.06dB
Power Spectral Density	±0.85 dB

This uncertainty represents an expanded uncertainty expressed at approximately the 95% confidence level using a coverage factor of $k = 2$.



2 GENERAL INFORMATION

2.1 GENERAL DESCRIPTION OF EUT

PRODUCT	Smart Desktop Terminal
BRAND NAME	PAX
MODEL NAME	A8500P, A8500N
NOMINAL VOLTAGE	5.0/9.0Vdc(adapter or host equipment)
MODULATION	OFDM
TRANSFER RATE	802.11a: 54.0/ 48.0/ 36.0/ 24.0/ 18.0/ 12.0/ 9.0/ 6.0Mbps 802.11n: up to 150.0Mbps 802.11ac: up to 433.3Mbps
OPERATING FREQUENCY	5180 ~ 5240MHz, 5260 ~ 5320MHz, 5500 ~ 5700MHz, 5745 ~ 5825MHz
NUMBER OF CHANNEL	5180 ~ 5240MHz: 4 for 802.11a, 802.11n/ac (20MHz) 2 for 802.11n/ac (40MHz) 1 for 802. 802.11ac(80MHz) 5260 ~ 5320MHz: 4 for 802.11a, 802.11n/ac (20MHz) 2 for 802.11n/ac (40MHz) 1 for 802.11ac (80MHz) 5500 ~ 5700MHz: 11 for 802.11a, 802.11n/ac (20MHz)/ 5 for 802.11n/ac (40MHz) 2 for 802.11ac (80MHz) 5745 ~ 5825MHz: 5 for 802.11a, 802.11n/ac (20MHz) 2 for 802.11n/ac (40MHz) 1 for 802.11ac (80MHz)
AVERAGE POWER	32.36mW for 5180 ~ 5240MHz 29.44mW for 5260 ~ 5320MHz 31.41mW for 5500 ~ 5700MHz 37.58mW for 5745 ~ 5825MHz
ANTENNA TYPE	PIFA Antenna
ANTENNA GAIN	2.6dBi for 5180 ~ 5240MHz 2.6dBi for 5260 ~ 5320MHz 2.6dBi for 5500 ~ 5700MHz 2.6dBi for 5745 ~ 5825MHz
HW VERSION	A8500P A8500N
SW VERSION	V0.0.0.1



I/O PORTS	Refer to user's manual
CABLE SUPPLIED	USB cable: non-shielded cable, with w/o ferrite core, 1.0 meter

NOTE:

1. For a more detailed features description, please refer to the manufacturer's specifications or the user's manual.
2. The EUT incorporates a SISO function. Physically, the EUT provides one completed transmitter and one receiver.

MODULATION MODE	TX FUNCTION
802.11a	1TX /1RX
802.11n/ac (20MHz)	1TX /1RX
802.11n/ac (40MHz)	1TX /1RX
802.11ac (80MHz)	1TX /1RX

3. For the test results, the EUT had been tested with all conditions. But only the worst case (A8500P) was shown in test report.



4. The difference of A8500N and A8500P is on below:

Object	A8500P	A8500N
Printer	Support	NO support
Adapter 1	Model Name : SW-0396A I/P: 100-240Vac,800mA, O/P: 9.0Vdc, 1000mA	Model Name: SW-0983 I/P: 100-240Vac, 500mA, O/P: 5.0Vdc,2000mA
Adapter 2	Model Name: G024A090100ZZUD I/P: 100-240Vac,800mA, O/P: 9.0Vdc, 1000mA	Model Name: GLH50E2000HW I/P: 100-240Vac, 500mA, O/P: 5.0Vdc,2000mA
LCD Panel 1	Supplier : Hubei Yiou Electronics Co., Ltd Model Name: YH-500BSC046C0-19A00-PTM0 Specifications : 5.0 inch/ 720*RGB*1280 Pixel	
LCD Panel 2	Supplier : Shenzhen Hongzhan Optoelectronics Co., Ltd Model Name: F6050812B-04 Specifications :5.0 inch/ 720*RGB*1280 Pixel	
Automatic operating voltage	Minimum voltage: 8.55V	Minimum voltage: 5.25V
	Normal voltage: 9V	Normal voltage: 5V
	Maximum voltage: 9.9V	Maximum voltage: 4.75V
Note: When the operating voltage changes, It does not affect RF, baseband module		



List of Accessory:

A8500N

ACCESSORIES	BRAND	MANUFACTURER	MODEL	SPECIFICATION
AC Adapter 1	PAX	XIAMEN KELI ELECTRONICS Co.,Ltd.	SW-0983	I/P: 100-240Vac, 0.5A, O/P: 5.0Vdc, 2A
AC Adapter 2	PAX	Shenzhen Sorghum Red Electronic Technology Co., Ltd	GLH50E2000HW	I/P: 100-240Vac, 0.4A, O/P: 5.0Vdc, 2A
USB Cable	N/A	N/A	N/A	Signal Line,1.0meter

A8500P

ACCESSORIES	BRAND	MANUFACTURER	MODEL	SPECIFICATION
AC Adapter 1	PAX	XIAMEN KELI ELECTRONICS Co.,Ltd.	SW-0396A	I/P: 100-240Vac, 0.5A, O/P: 9.0Vdc, 1A
AC Adapter 2	PAX	Shenzhen Sorghum Red Electronic Technology Co., Ltd	G024A090100ZZ UD	I/P: 100-240Vac, 0.8A, O/P: 9.0Vdc, 1A



2.2 DESCRIPTION OF TEST MODES

FOR 5180 ~ 5240MHz

4 channels are provided for 802.11a, 802.11 n/ac (20MHz):

CHANNEL	FREQUENCY	CHANNEL	FREQUENCY
36	5180 MHz	44	5220 MHz
40	5200 MHz	48	5240 MHz

2 channels are provided for 802.11 n/ac (40MHz):

CHANNEL	FREQUENCY	CHANNEL	FREQUENCY
38	5190 MHz	46	5230 MHz

1 channel is provided for 802.11ac (80MHz):

CHANNEL	FREQUENCY	CHANNEL	FREQUENCY
42	5210 MHz		

FOR 5260 ~ 5320MHz

4 channels are provided for 802.11a, 802.11 n/ac (20MHz):

CHANNEL	FREQUENCY	CHANNEL	FREQUENCY
52	5260 MHz	60	5300 MHz
56	5280 MHz	64	5320 MHz

2 channels are provided for 802.11 n/ac (40MHz):

CHANNEL	FREQUENCY	CHANNEL	FREQUENCY
54	5270 MHz	62	5310 MHz

1 channel is provided for 802.11ac (80MHz):

CHANNEL	FREQUENCY	CHANNEL	FREQUENCY
58	5290 MHz		



FOR 5500 ~ 5700MHz

11 channels are provided for 802.11a, 802.11 n/ac (20MHz):

CHANNEL	FREQUENCY	CHANNEL	FREQUENCY
100	5500 MHz	124	5620MHz
104	5520 MHz	128	5640MHz
108	5540 MHz	132	5660 MHz
112	5560 MHz	136	5680 MHz
116	5580 MHz	140	5700 MHz
120	5600 MHz		

5 channels are provided for 802.11 n/ac (40MHz):

CHANNEL	FREQUENCY	CHANNEL	FREQUENCY
102	5510 MHz	126	5630MHz
110	5550 MHz	134	5670 MHz
118	5590 MHz		

2 channel is provided for 802.11ac (80MHz):

CHANNEL	FREQUENCY	CHANNEL	FREQUENCY
106	5530 MHz	122	5610 MHz



FOR 5745 ~ 5825MHz

5 channels are provided for 802.11a, 802.11n/ac (20MHz):

CHANNEL	FREQUENCY	CHANNEL	FREQUENCY
149	5745 MHz	161	5805 MHz
153	5765 MHz	165	5825 MHz
157	5785 MHz		

2 channels are provided for 802.11 n/ac (40MHz):

CHANNEL	FREQUENCY	CHANNEL	FREQUENCY
151	5755 MHz	159	5795 MHz

1 channel is provided for 802.11ac (80MHz):

CHANNEL	FREQUENCY
155	5775 MHz



2.2.1 TEST MODE APPLICABILITY AND TESTED CHANNEL DETAIL

EUT CONFIGURE MODE	APPLICABLE TO				DESCRIPTION
	RE≥1G	RE<1G	PLC	APCM	
A	√	√	√	-	Powered by Adapter with wifi(5G) link
B	-	-	-	√	Powered by Battery with wifi(5G) link
C	-	-	-	-	Powered by USB with wifi(5G) link

Where **RE≥1G**: Radiated Emission above 1GHz **RE<1G**: Radiated Emission below 1GHz
PLC: Power Line Conducted Emission **APCM**: Antenna Port Conducted Measurement

NOTE:
The EUT had been pre-tested on the positioned of each 3 axis. The worst case was found when positioned on **X-plane**.
NOTE: "-" means no effect.

RADIATED EMISSION TEST (BELOW 1GHz):

- Pre-Scan has been conducted to determine the worst-case mode from all possible combinations between available modulations, data rates and antenna ports (if EUT with antenna diversity architecture).
- Following channel(s) was (were) selected for the final test as listed below.

EUT CONFIGURE MODE	MODE	FREQ. BAND (MHz)	AVAILABLE CHANNEL	TESTED CHANNEL	MODULATION	DATA RATE (Mbps)
A	802.11ac (20MHz)	5745-5825	149 to 165	157	OFDM	MCS0



RADIATED EMISSION TEST (ABOVE 1GHz):

- Pre-Scan has been conducted to determine the worst-case mode from all possible combinations between available modulations, data rates and antenna ports (if EUT with antenna diversity architecture).
- Following channel(s) was (were) selected for the final test as listed below.

EUT CONFIGURE MODE	MODE	FREQ. BAND (MHz)	AVAILABLE CHANNEL	TESTED CHANNEL	MODULATION	DATA RATE (Mbps)
A	802.11a	5180-5240	36 to 48	36, 48	OFDM	6.0
A	802.11an/ac (20MHz)		36 to 48	36, 48	OFDM	MCS0
A	802.11an/ac (40MHz)		38 to 46	38, 46	OFDM	MCS0
A	802.11ac (80MHz)		42	42	OFDM	MCS0
A	802.11a	5260-5320	52 to 64	52, 60, 64	OFDM	6.0
A	802.11an/ac (20MHz)		52 to 64	52, 60, 64	OFDM	MCS0
A	802.11an/ac (40MHz)		54 to 62	54, 62	OFDM	MCS0
A	802.11ac (80MHz)		58	58	OFDM	MCS0
A	802.11a	5500-5700	100 to 140	100, 116, 140	OFDM	6.0
A	802.11an/ac (20MHz)		100 to 140	100, 116, 140	OFDM	MCS0
A	802.11an/ac (40MHz)		102 to 134	102, 110, 134	OFDM	MCS0
A	802.11ac (80MHz)		106 to 122	106, 122	OFDM	MCS0
A	802.11a	5745-5825	149 to 165	149, 157, 165	OFDM	6.0
A	802.11an/ac (20MHz)		149 to 165	149, 157, 165	OFDM	MCS0
A	802.11an/ac (40MHz)		151 to 159	151, 159	OFDM	MCS0
A	802.11ac (80MHz)		155	155	OFDM	MCS0

POWER LINE CONDUCTED EMISSION TEST:

- Pre-Scan has been conducted to determine the worst-case mode from all possible combinations between available modulations, data rates and antenna ports (if EUT with antenna diversity architecture).
- Following channel(s) was (were) selected for the final test as listed below.

EUT CONFIGURE MODE	MODE	FREQ. BAND (MHz)	AVAILABLE CHANNEL	TESTED CHANNEL	MODULATION	DATA RATE (Mbps)
A	802.11ac (20MHz)	5745-5825	149 to 165	157	OFDM	MCS0



BANDEDGE MEASUREMENT:

- Pre-Scan has been conducted to determine the worst-case mode from all possible combinations between available modulations, data rates and antenna ports (if EUT with antenna diversity architecture).
- Following channel(s) was (were) selected for the final test as listed below.

EUT CONFIGURE MODE	MODE	FREQ. BAND (MHz)	AVAILABLE CHANNEL	TESTED CHANNEL	MODULATION	DATA RATE (Mbps)
A	802.11a	5180-5240	36 to 48	36, 48	OFDM	6.0
A	802.11an/ac (20MHz)		36 to 48	36, 48	OFDM	MCS0
A	802.11an/ac (40MHz)		38 to 46	38, 46	OFDM	MCS0
A	802.11ac (80MHz)		42	42	OFDM	MCS0
A	802.11a	5260-5320	52 to 64	52, 60, 64	OFDM	6.0
A	802.11an/ac (20MHz)		52 to 64	52, 60, 64	OFDM	MCS0
A	802.11an/ac (40MHz)		54 to 62	54, 62	OFDM	MCS0
A	802.11ac (80MHz)		58	58	OFDM	MCS0
A	802.11a	5500-5700	100 to 140	100, 116, 140	OFDM	6.0
A	802.11an/ac (20MHz)		100 to 140	100, 116, 140	OFDM	MCS0
A	802.11an/ac (40MHz)		102 to 134	102, 110, 134	OFDM	MCS0
A	802.11ac (80MHz)		106 to 122	106, 122	OFDM	MCS0
A	802.11a	5745-5825	149 to 165	149, 157,165	OFDM	6.0
A	802.11an/ac (20MHz)		149 to 165	149, 157,165	OFDM	MCS0
A	802.11an/ac (40MHz)		151 to 159	151, 159	OFDM	MCS0
A	802.11ac (80MHz)		155	155	OFDM	MCS0



ANTENNA PORT CONDUCTED MEASUREMENT:

- This item includes all test value of each mode, but only includes spectrum plot of worst value of each mode.
- Pre-Scan has been conducted to determine the worst-case mode from all possible combinations between available modulations, data rates and antenna ports (if EUT with antenna diversity architecture).
- Following channel(s) was (were) selected for the final test as listed below.

EUT CONFIGURE MODE	MODE	FREQ. BAND (MHz)	AVAILABLE CHANNEL	TESTED CHANNEL	MODULATION	DATA RATE (Mbps)
A	802.11a	5180-5240	36 to 48	36, 48	OFDM	6.0
A	802.11an/ac (20MHz)		36 to 48	36, 48	OFDM	MCS0
A	802.11an/ac (40MHz)		38 to 46	38, 46	OFDM	MCS0
A	802.11ac (80MHz)		42	42	OFDM	MCS0
A	802.11a	5260-5320	52 to 64	52, 60, 64	OFDM	6.0
A	802.11an/ac (20MHz)		52 to 64	52, 60, 64	OFDM	MCS0
A	802.11an/ac (40MHz)		54 to 62	54, 62	OFDM	MCS0
A	802.11ac (80MHz)		58	58	OFDM	MCS0
A	802.11a	5500-5700	100 to 140	100, 116, 140	OFDM	6.0
A	802.11an/ac (20MHz)		100 to 140	100, 116, 140	OFDM	MCS0
A	802.11an/ac (40MHz)		102 to 134	102, 110, 134	OFDM	MCS0
A	802.11ac (80MHz)		106 to 122	106, 122	OFDM	MCS0
A	802.11a	5745-5825	149 to 165	149, 157,165	OFDM	6.0
A	802.11an/ac (20MHz)		149 to 165	149, 157,165	OFDM	MCS0
A	802.11an/ac (40MHz)		151 to 159	151, 159	OFDM	MCS0
A	802.11ac (80MHz)		155	155	OFDM	MCS0



Test Report No.: W7L-P23050004-1RF03

TEST CONDITION:

APPLICABLE TO	ENVIRONMENTAL CONDITIONS	INPUT POWER	TESTED BY
RE<1G	23deg. C, 56%RH	DC 5/9V By Adapter	Jace Hu
RE≥1G	23deg. C, 56%RH	DC 5/9V By Adapter	Jace Hu
PLC	25deg. C, 52%RH	DC 5/9V By Adapter	James Fu
APCM	25deg. C, 60%RH	DC 5/9V By Adapter	James Fu



2.3 DUTY CYCLE OF TEST SIGNAL

Please Refer to Appendix A Of this test report.

WORST-CASE DATA:

Measured Duty Cycle		
Mode		Duty Cycle [%]
		ANT1
5GHZ	11a	90.73
	11n20	90.14
	11n40	81.01
	11ac20	90.21
	11ac40	82.05
	11ac80	66.67

Note:

Duty cycle of test signal is < 98%, duty factor shall be considered.

2.4 DESCRIPTION OF SUPPORT UNITS

The EUT has been tested as an independent unit together with other necessary accessories or support units. The following support units or accessories were used to form a representative test configuration during the tests.

NO.	PRODUCT	BRAND	MODEL NO.	SERIAL NO.	FCC ID
1	Desktop	Lenovo	M73 SFF	PC04GRQV	N/A
2	Desktop	Lenovo	M73 SFF	PC06CS27	N/A
3	Laptop	Lenovo	Thinkpad L440	R90FTFKN	N/A
4	DC source	Kikusui/JP	PMX18-5A	0000001	N/A

NO.	SIGNAL CABLE DESCRIPTION OF THE ABOVE SUPPORT UNITS
1	AC Line: Unshielded, Detachable 1.5m
2	AC Line: Unshielded, Detachable 1.5m
3	AC Line: Unshielded, Detachable 1.5m
4	DC Line: Unshielded, Detachable 1.0m



2.4.1 CONFIGURATION OF SYSTEM UNDER TEST

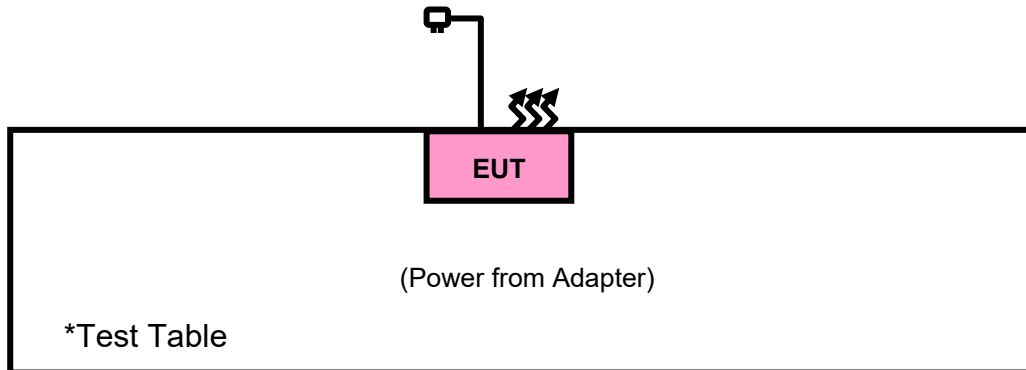

2.5 GENERAL DESCRIPTION OF APPLIED STANDARDS

The EUT is a RF Product. According to the specifications of the manufacturer, it must comply with the requirements of the following standards:

FCC Part 15, Subpart E (15.407)

KDB 789033 D02 General U-NII Test Procedures New Rules v02r01

ANSI C63.10-2013

All test items have been performed and recorded as per the above standards.

NOTE: The EUT is also considered as a kind of computer peripheral, because the connection to computer is necessary for typical use. It has been verified to comply with the requirements of FCC Part 15, Subpart B, Class B (Certification). The test report has been issued separately.



3 TEST TYPES AND RESULTS

3.1 RADIATED EMISSION AND BANDEDGE MEASUREMENT

3.1.1 LIMITS OF RADIATED EMISSION AND BANDEDGE MEASUREMENT

Radiated emissions which fall in the restricted bands must comply with the radiated emission limits specified as below table:

FREQUENCIES (MHz)	FIELD STRENGTH (microvolts/meter)	MEASUREMENT DISTANCE (meters)
0.009 ~ 0.490	2400/F(kHz)	300
0.490 ~ 1.705	24000/F(kHz)	30
1.705 ~ 30.0	30	30
30 ~ 88	100	3
88 ~ 216	150	3
216 ~ 960	200	3
Above 960	500	3

NOTE:

1. The lower limit shall apply at the transition frequencies.
2. Emission level (dBuV/m) = 20 log Emission level (uV/m).
3. For frequencies above 1000MHz, the field strength limits are based on average detector, however, the peak field strength of any emission shall not exceed the maximum permitted average limits, specified above by more than 20dB under any condition of modulation.

3.1.2 LIMITS OF UNWANTED EMISSION

RESTRICTED BANDS	APPLICABLE TO	LIMIT	
	789033 D02 General UNII Test Procedures New Rules v02r01	FIELD STRENGTH AT 3m (dBµV/m)	
	PK : 74	AV : 54	
OUT OF THE RESTRICTED BANDS	APPLICABLE TO	EIRP LIMIT (dBm/MHz)	EQUIVALENT FIELD STRENGTH AT 3m (dBµV/m)
	15.407(b)(1)	PK : -27	PK : 68.2
	15.407(b)(2)		
	15.407(b)(3)		
15.407(b)(4)	See note 2 (FCC 16-24)		



NOTE: The following formula is used to convert the equipment isotropic radiated power (eirp) to field strength:

E = (1000000*sqrt(30P))/3 μV/m, where P is the eirp (Watts).

2. All emissions shall be limited to a level of -27 dBm/MHz at 75 MHz or more above or below the band edge increasing linearly to 10 dBm/MHz at 25 MHz above or below the band edge, and from 25 MHz above or below the band edge increasing linearly to a level of 15.6 dBm/MHz at 5 MHz above or below the band edge, and from 5 MHz above or below the band edge increasing linearly to a level of 27 dBm/MHz at the band edge.

3.1.3 TEST INSTRUMENTS

Table with 6 columns: Equipment, Manufacturer, Model No., Serial No., Last Cal., Next Cal. It lists various test instruments such as Semi-anechoic Chambers, Antennas, Software, Attenuators, Receivers, Amplifiers, DC Source, Power Meter, Power Sensor, and Loop Antenna.

NOTE: 1. The calibration interval of the above test instruments is 12 months or 36 months and the calibrations are traceable to CEPREI/CHINA, GRGT/CHINA and NIM/CHINA.

2. The test was performed in 3m Chamber.

3. The FCC Site Registration No. is 525120; The Designation No. is CN1171.



3.1.4 TEST PROCEDURES

- a. The EUT was placed on the top of a rotating table 0.8 meters (for below 1GHz) / 1.5 meters (for above 1GHz) above the ground at 3 meter chamber room for test. The table was rotated 360 degrees to determine the position of the highest radiation.
- b. The EUT was set 3 meters away from the interference-receiving antenna, which was mounted on the top of a variable-height antenna tower.
- c. The antenna is a broadband antenna, and its height is varied from one meter to four meters above the ground to determine the maximum value of the field strength. Both horizontal and vertical polarizations of the antenna are set to make the measurement.
- d. For each suspected emission, the EUT was arranged to its worst case and then the antenna was tuned to heights from 1 meter to 4 meters and the rotatable table was turned from 0 degrees to 360 degrees to find the maximum reading.
- e. The test-receiver system was set to Peak Detect Function and Specified Bandwidth with Maximum Hold Mode.
- f. If the emission level of the EUT in peak mode was 10dB lower than the limit specified, then testing could be stopped and the peak values of the EUT would be reported. Otherwise the emissions that did not have 10dB margin would be re-tested one by one using peak, quasi-peak or average method as specified and then reported in a data sheet.

NOTE:

1. The resolution bandwidth and video bandwidth of test receiver/spectrum analyzer is 120kHz for Peak detection (PK) and Quasi-peak detection (QP) at frequency below 1GHz.
2. The resolution bandwidth of test receiver/spectrum analyzer is 1MHz and video bandwidth is 3MHz for Peak detection at frequency above 1GHz.
3. The resolution bandwidth of test receiver/spectrum analyzer is 1MHz and the video bandwidth is 3MHz for RMS Average (Duty cycle < 98%) for Average detection (AV) at frequency above 1GHz, then the measurement results was added to a correction factor ($10 \log(1/\text{duty cycle})$).
4. The resolution bandwidth of test receiver/spectrum analyzer is 1MHz and the video bandwidth is 10Hz (Duty cycle $\geq 98\%$) for Average detection (AV) at frequency above 1GHz.
5. All modes of operation were investigated and the worst-case emissions are reported.

3.1.5 DEVIATION FROM TEST STANDARD

No deviation.



3.1.6 TEST SETUP

<Frequency Range 9KHz~30MHz >

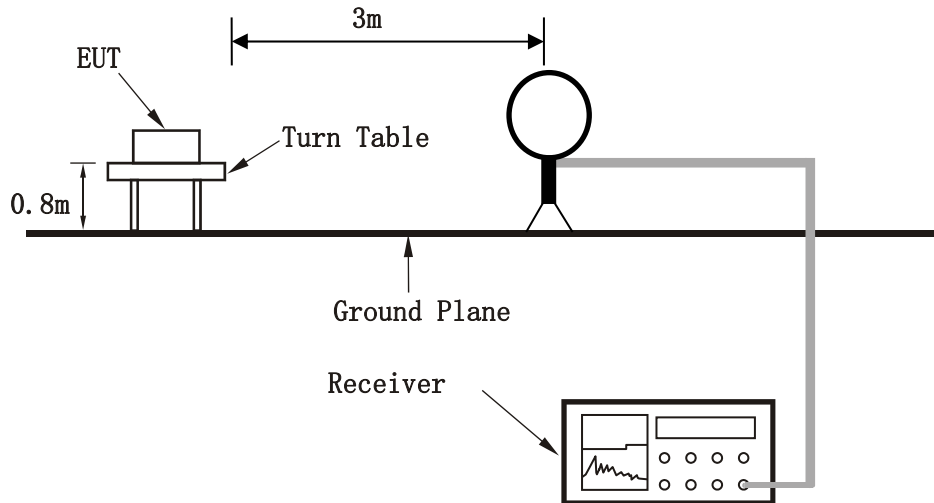

< Frequency Range 30MHz~1GHz >

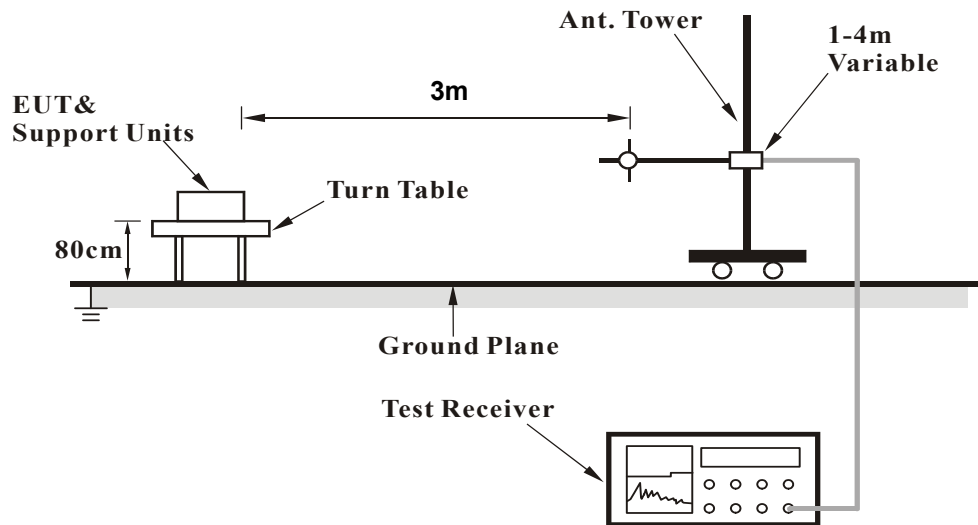

<Frequency Range above 1GHz>

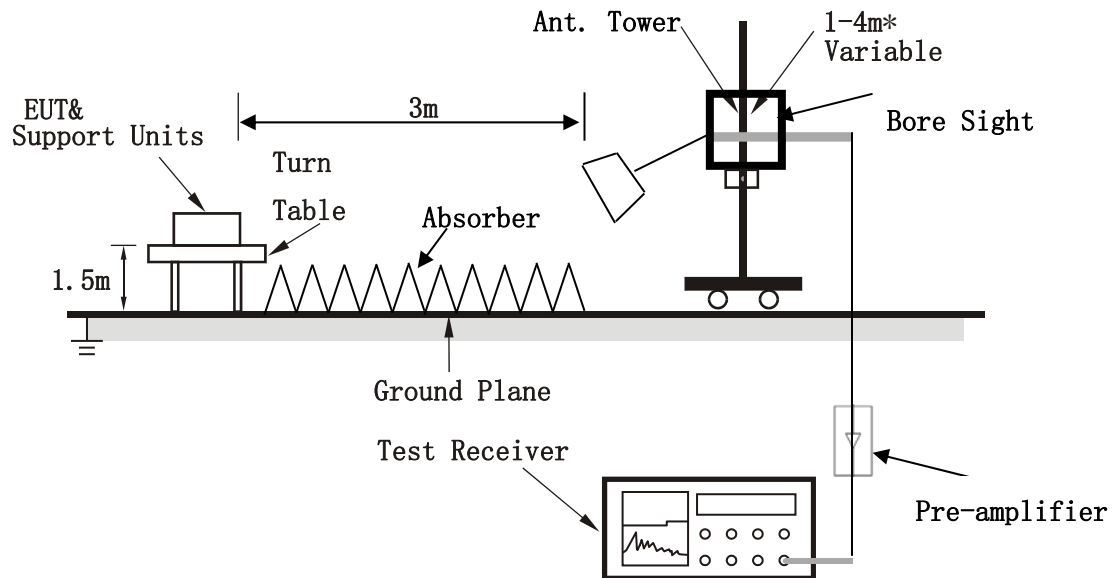

Note: Above 1G is a directional antenna

Depends on the EUT height and the antenna 3dB beamwidth both, refer to section 7.3 of CISPR 16-2-3.

For the actual test configuration, please refer to the attached file (Test Setup Photo).

3.1.7 EUT OPERATING CONDITION

- Set the EUT under full load condition and placed them on a testing table.
- Set the transmitter part of EUT under transmission condition continuously at specific channel frequency.
- The necessary accessories enable the EUT in full functions.



3.1.8 TEST RESULTS

NOTE : The 9K~30MHz amplitude of spurious emissions attenuated more than 20 dB below the permissible value is not required in the report.

30 MHz – 1GHz data:

Band 2

802.11ac (80MHz)

CHANNEL	TX Channel 58	DETECTOR FUNCTION	Quasi-Peak (QP)
FREQUENCY RANGE	30MHz ~ 1GHz		

ANTENNA POLARITY & TEST DISTANCE: HORIZONTAL AT 3 M										
FREQ. (MHz)	EMISSION LEVEL (dBuV/m)	READ LEVEL (dBuV)	LIMIT (dBuV/m)	MARGIN (dB)	ANTENNA FACTOR (dB /m)	CABLE LOSS (dB)	PREAMP FACTOR (dB)	ANTENNA HEIGHT (cm)	TABLE ANGLE (Degree)	REMARK
52.31	22.8	49.41	40	-17.2	9.97	0.41	36.99	145	94	Peak
191.99	18.19	42.46	43.5	-25.31	11.34	0.72	36.33	108	65	Peak
359.8	25.42	45.45	46	-20.58	15.32	1.01	36.36	174	174	Peak
399.57	33.85	53.01	46	-12.15	16.19	1.07	36.42	163	22	Peak
480.08	20.22	37.89	46	-25.78	17.72	1.19	36.58	121	113	Peak
800.18	28.95	42.17	46	-17.05	22.4	1.58	37.2	101	147	Peak

REMARKS:

1. Emission level (dBuV/m) = Read level (dBuV) + Correction Factor (dB/m).
2. Correction Factor (dB/m) = Antenna Factor (dB/m) + Cable Factor (dB).
3. The other emission levels were very low against the limit.
4. Margin value = Emission level – Limit value.

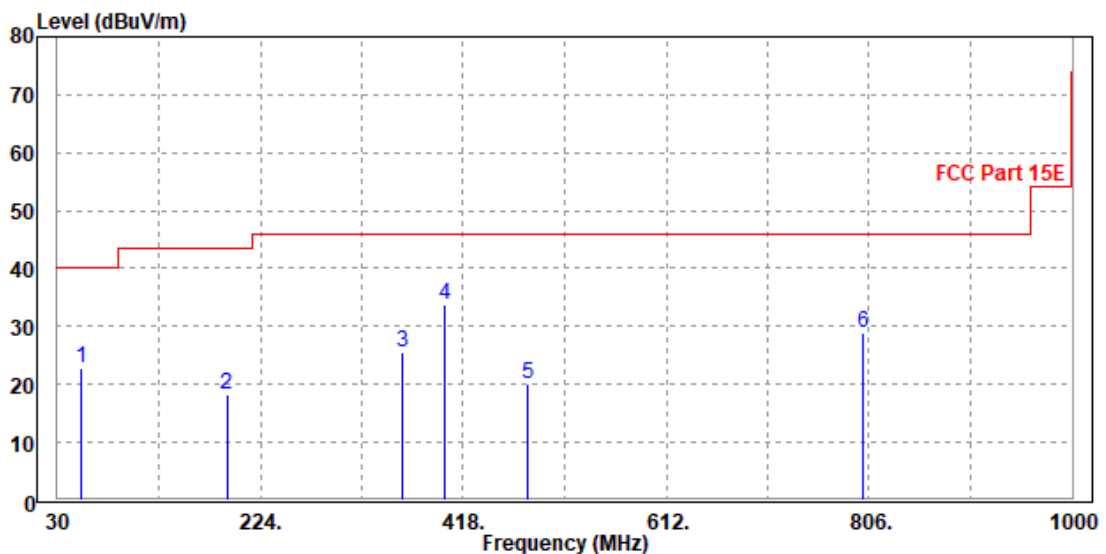



CHANNEL	Channel 58	DETECTOR FUNCTION	Quasi-Peak (QP)
FREQUENCY RANGE	30MHz ~ 1GHz		

ANTENNA POLARITY & TEST DISTANCE: VERTICAL AT 3 M										
FREQ. (MHz)	EMISSION LEVEL (dBuV/m)	READ LEVEL (dBuV)	LIMIT (dBuV/m)	MARGIN (dB)	ANTENNA FACTOR (dB /m)	CABLE LOSS (dB)	PREAMP FACTOR (dB)	ANTENNA HEIGHT (cm)	TABLE ANGLE (Degree)	REMARK
35.82	23.5	43.61	40	-16.5	16.88	0.34	37.33	120	126	Peak
68.8	19.43	47.76	40	-20.57	8.16	0.47	36.96	128	296	Peak
181.32	21.56	46.02	43.5	-21.94	11.22	0.71	36.39	156	176	Peak
359.8	20.53	40.5	46	-25.47	15.38	1.01	36.36	168	201	Peak
399.57	29.01	48.07	46	-16.99	16.29	1.07	36.42	100	30	Peak
480.08	25.46	43.51	46	-20.54	17.34	1.19	36.58	155	358	Peak

REMARKS:

1. Emission level (dBuV/m) = Read level (dBuV) + Correction Factor (dB/m).
2. Correction Factor (dB/m) = Antenna Factor (dB/m) + Cable Factor (dB).
3. The other emission levels were very low against the limit.
4. Margin value = Emission level – Limit value.

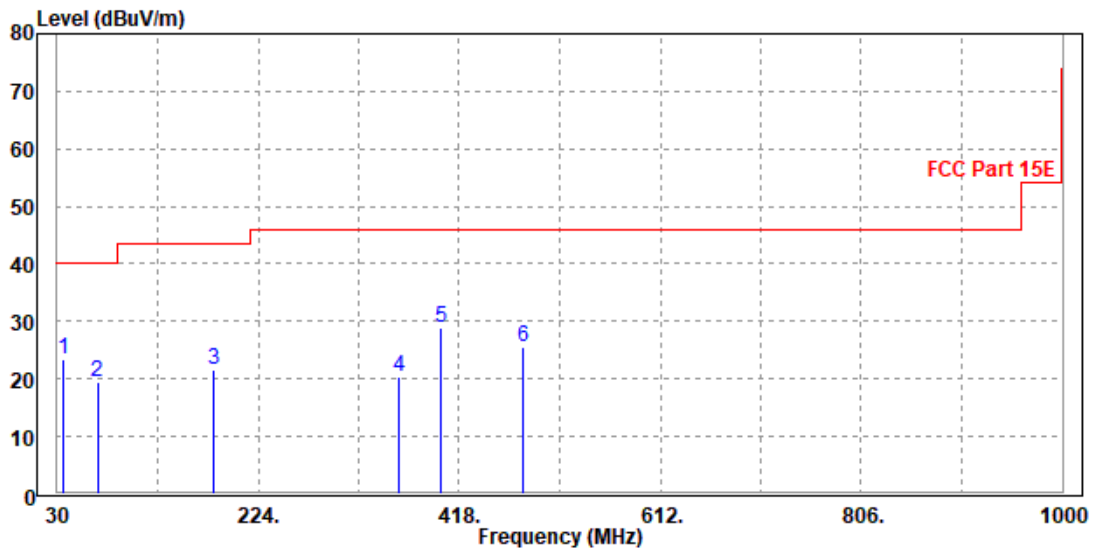



ABOVE 1GHz WORST-CASE DATA:

Note: For higher frequency, the emission is too low to be detected.

Band 1

802.11a

CHANNEL	TX Channel 36	DETECTOR FUNCTION	Peak (PK)
FREQUENCY RANGE	1GHz ~ 40GHz		Average (AV)

ANTENNA POLARITY & TEST DISTANCE: HORIZONTAL AT 3 M

FREQ. (MHz)	EMISSION LEVEL (dBuV/m)	READ LEVEL (dBuV)	LIMIT (dBuV/m)	MARGIN (dB)	ANTENNA FACTOR (dB /m)	CABLE LOSS (dB)	PREAMP FACTOR (dB)	ANTENNA HEIGHT (cm)	TABLE ANGLE (Degree)	REMARK
5150	61.12	62.19	74.00	-12.88	34.52	9.92	45.51	200	60	Peak
5150	50.21	51.28	54.00	-3.79	34.52	9.92	45.51	200	60	Average
5180	105.82	106.88	/	/	34.54	9.91	45.51	200	60	Peak
5180	98.59	99.65	/	/	34.54	9.91	45.51	200	60	Average
5350	55.25	56.23	74.00	-18.75	34.68	9.85	45.51	200	60	Peak
5350	48.64	49.62	54.00	-5.36	34.68	9.85	45.51	200	60	Average

ANTENNA POLARITY & TEST DISTANCE: VERTICAL AT 3 M

FREQ. (MHz)	EMISSION LEVEL (dBuV/m)	READ LEVEL (dBuV)	LIMIT (dBuV/m)	MARGIN (dB)	ANTENNA FACTOR (dB /m)	CABLE LOSS (dB)	PREAMP FACTOR (dB)	ANTENNA HEIGHT (cm)	TABLE ANGLE (Degree)	REMARK
5150	59.12	60.11	74.00	-14.88	34.60	9.92	45.51	100	300	Peak
5150	49.96	50.95	54.00	-4.04	34.60	9.92	45.51	100	300	Average
5180	103.30	104.30	/	/	34.60	9.91	45.51	100	300	Peak
5180	96.56	97.56	/	/	34.60	9.91	45.51	100	300	Average
5350	56.44	57.50	74.00	-17.56	34.60	9.85	45.51	100	300	Peak
5350	47.89	48.95	54.00	-6.11	34.60	9.85	45.51	100	300	Average

REMARKS:

- Emission Level = Read Level+ Antenna Factor + Cable Loss- Preamp Factor
Margin value = Emission level – Limit value.
- 5180MHz: Fundamental frequency.



CHANNEL	TX Channel 40	DETECTOR FUNCTION	Peak (PK)
FREQUENCY RANGE	1GHz ~ 40GHz		Average (AV)

ANTENNA POLARITY & TEST DISTANCE: HORIZONTAL AT 3 M

FREQ. (MHz)	EMISSION LEVEL (dBuV/m)	READ LEVEL (dBuV)	LIMIT (dBuV/m)	MARGIN (dB)	ANTENNA FACTOR (dB /m)	CABLE LOSS (dB)	PREAMP FACTOR (dB)	ANTENNA HEIGHT (cm)	TABLE ANGLE (Degree)	REMARK
5150	54.42	55.49	74.00	-19.58	34.52	9.92	45.51	200	60	Peak
5150	48.26	49.33	54.00	-5.74	34.52	9.92	45.51	200	60	Average
5200	104.51	105.56	/	/	34.56	9.90	45.51	200	60	Peak
5200	98.93	99.98	/	/	34.56	9.90	45.51	200	60	Average
5350	54.78	55.76	74.00	-19.22	34.68	9.85	45.51	200	60	Peak
5350	47.37	48.35	54.00	-6.63	34.68	9.85	45.51	200	60	Average

ANTENNA POLARITY & TEST DISTANCE: VERTICAL AT 3 M

FREQ. (MHz)	EMISSION LEVEL (dBuV/m)	READ LEVEL (dBuV)	LIMIT (dBuV/m)	MARGIN (dB)	ANTENNA FACTOR (dB /m)	CABLE LOSS (dB)	PREAMP FACTOR (dB)	ANTENNA HEIGHT (cm)	TABLE ANGLE (Degree)	REMARK
5150	53.95	54.94	74.00	-20.05	34.60	9.92	45.51	100	300	Peak
5150	48.07	49.06	54.00	-5.93	34.60	9.92	45.51	100	300	Average
5200	103.71	104.72	/	/	34.60	9.90	45.51	100	300	Peak
5200	95.38	96.39	/	/	34.60	9.90	45.51	100	300	Average
5350	52.80	53.86	74.00	-21.20	34.60	9.85	45.51	100	300	Peak
5350	47.73	48.79	54.00	-6.27	34.60	9.85	45.51	100	300	Average

REMARKS:

- Emission Level = Read Level+ Antenna Factor + Cable Loss- Preamp Factor
Margin value = Emission level – Limit value.
- 5200MHz: Fundamental frequency.



CHANNEL	TX Channel 48	DETECTOR FUNCTION	Peak (PK)
FREQUENCY RANGE	1GHz ~ 40GHz		Average (AV)

ANTENNA POLARITY & TEST DISTANCE: HORIZONTAL AT 3 M										
FREQ. (MHz)	EMISSION LEVEL (dBuV/m)	READ LEVEL (dBuV)	LIMIT (dBuV/m)	MARGIN (dB)	ANTENNA FACTOR (dB /m)	CABLE LOSS (dB)	PREAMP FACTOR (dB)	ANTENNA HEIGHT (cm)	TABLE ANGLE (Degree)	REMARK
5150	53.29	54.36	74.00	-20.71	34.52	9.92	45.51	200	60	Peak
5150	48.21	49.28	54.00	-5.79	34.52	9.92	45.51	200	60	Average
5240	105.18	106.21	/	/	34.59	9.89	45.51	200	60	Peak
5240	108.82	109.85	/	/	34.59	9.89	45.51	200	60	Average
5350	55.25	56.23	74.00	-18.75	34.68	9.85	45.51	200	60	Peak
5350	49.05	50.03	54.00	-4.95	34.68	9.85	45.51	200	60	Average
ANTENNA POLARITY & TEST DISTANCE: VERTICAL AT 3 M										
FREQ. (MHz)	EMISSION LEVEL (dBuV/m)	READ LEVEL (dBuV)	LIMIT (dBuV/m)	MARGIN (dB)	ANTENNA FACTOR (dB /m)	CABLE LOSS (dB)	PREAMP FACTOR (dB)	ANTENNA HEIGHT (cm)	TABLE ANGLE (Degree)	REMARK
5150	53.32	54.31	74.00	-20.68	34.60	9.92	45.51	100	300	Peak
5150	47.30	48.29	54.00	-6.70	34.60	9.92	45.51	100	300	Average
5240	103.50	104.52	/	/	34.60	9.89	45.51	100	300	Peak
5240	96.32	97.34	/	/	34.60	9.89	45.51	100	300	Average
5350	53.09	54.15	74.00	-20.91	34.60	9.85	45.51	100	300	Peak
5350	47.24	48.30	54.00	-6.76	34.60	9.85	45.51	100	300	Average

REMARKS:

- Emission Level = Read Level+ Antenna Factor + Cable Loss- Preamp Factor
Margin value = Emission level – Limit value.
- 5240MHz: Fundamental frequency.



802.11n (20MHz)

CHANNEL	TX Channel 36	DETECTOR FUNCTION	Peak (PK)
FREQUENCY RANGE	1GHz ~ 40GHz		Average (AV)

ANTENNA POLARITY & TEST DISTANCE: HORIZONTAL AT 3 M										
FREQ. (MHz)	EMISSION LEVEL (dBuV/m)	READ LEVEL (dBuV)	LIMIT (dBuV/m)	MARGIN (dB)	ANTENNA FACTOR (dB /m)	CABLE LOSS (dB)	PREAMP FACTOR (dB)	ANTENNA HEIGHT (cm)	TABLE ANGLE (Degree)	REMARK
5150	56.73	57.80	74.00	-17.27	34.52	9.92	45.51	200	60	Peak
5150	49.88	50.95	54.00	-4.12	34.52	9.92	45.51	200	60	Average
5180	104.67	105.73	/	/	34.54	9.91	45.51	200	60	Peak
5180	98.09	99.15	/	/	34.54	9.91	45.51	200	60	Average
5350	53.08	54.06	74.00	-20.92	34.68	9.85	45.51	200	60	Peak
5350	47.61	48.59	54.00	-6.39	34.68	9.85	45.51	200	60	Average
ANTENNA POLARITY & TEST DISTANCE: VERTICAL AT 3 M										
FREQ. (MHz)	EMISSION LEVEL (dBuV/m)	READ LEVEL (dBuV)	LIMIT (dBuV/m)	MARGIN (dB)	ANTENNA FACTOR (dB /m)	CABLE LOSS (dB)	PREAMP FACTOR (dB)	ANTENNA HEIGHT (cm)	TABLE ANGLE (Degree)	REMARK
5150	55.64	56.63	74.00	-18.36	34.60	9.92	45.51	100	300	Peak
5150	49.27	50.26	54.00	-4.73	34.60	9.92	45.51	100	300	Average
5180	102.16	103.16	/	/	34.60	9.91	45.51	100	300	Peak
5180	95.87	96.87	/	/	34.60	9.91	45.51	100	300	Average
5350	53.66	54.72	74.00	-20.34	34.60	9.85	45.51	100	300	Peak
5350	47.51	48.57	54.00	-6.49	34.60	9.85	45.51	100	300	Average

REMARKS:

- Emission Level = Read Level+ Antenna Factor + Cable Loss- Preamp Factor
Margin value = Emission level – Limit value.
- 5180MHz: Fundamental frequency.



CHANNEL	TX Channel 40	DETECTOR FUNCTION	Peak (PK)
FREQUENCY RANGE	1GHz ~ 40GHz		Average (AV)

ANTENNA POLARITY & TEST DISTANCE: HORIZONTAL AT 3 M

FREQ. (MHz)	EMISSION LEVEL (dBuV/m)	READ LEVEL (dBuV)	LIMIT (dBuV/m)	MARGIN (dB)	ANTENNA FACTOR (dB /m)	CABLE LOSS (dB)	PREAMP FACTOR (dB)	ANTENNA HEIGHT (cm)	TABLE ANGLE (Degree)	REMARK
5150	53.63	54.70	74.00	-20.37	34.52	9.92	45.51	200	60	Peak
5150	48.19	49.26	54.00	-5.81	34.52	9.92	45.51	200	60	Average
5200	104.45	105.50	/	/	34.56	9.90	45.51	200	60	Peak
5200	97.29	98.34	/	/	34.56	9.90	45.51	200	60	Average
5350	53.54	54.52	74.00	-20.46	34.68	9.85	45.51	200	60	Peak
5350	47.23	48.21	54.00	-6.77	34.68	9.85	45.51	200	60	Average

ANTENNA POLARITY & TEST DISTANCE: VERTICAL AT 3 M

FREQ. (MHz)	EMISSION LEVEL (dBuV/m)	READ LEVEL (dBuV)	LIMIT (dBuV/m)	MARGIN (dB)	ANTENNA FACTOR (dB /m)	CABLE LOSS (dB)	PREAMP FACTOR (dB)	ANTENNA HEIGHT (cm)	TABLE ANGLE (Degree)	REMARK
5150	53.14	54.13	74.00	-20.86	34.60	9.92	45.51	100	300	Peak
5150	47.29	48.28	54.00	-6.71	34.60	9.92	45.51	100	300	Average
5200	101.74	102.75	/	/	34.60	9.90	45.51	100	300	Peak
5200	94.81	95.82	/	/	34.60	9.90	45.51	100	300	Average
5350	53.92	54.98	74.00	-20.08	34.60	9.85	45.51	100	300	Peak
5350	46.87	47.93	54.00	-7.13	34.60	9.85	45.51	100	300	Average

REMARKS:

- Emission Level = Read Level+ Antenna Factor + Cable Loss- Preamp Factor
Margin value = Emission level – Limit value.
- 5200MHz: Fundamental frequency.



CHANNEL	TX Channel 48	DETECTOR FUNCTION	Peak (PK)
FREQUENCY RANGE	1GHz ~ 40GHz		Average (AV)

ANTENNA POLARITY & TEST DISTANCE: HORIZONTAL AT 3 M

FREQ. (MHz)	EMISSION LEVEL (dBuV/m)	READ LEVEL (dBuV)	LIMIT (dBuV/m)	MARGIN (dB)	ANTENNA FACTOR (dB /m)	CABLE LOSS (dB)	PREAMP FACTOR (dB)	ANTENNA HEIGHT (cm)	TABLE ANGLE (Degree)	REMARK
5150	53.64	54.71	74.00	-20.36	34.52	9.92	45.51	200	60	Peak
5150	47.71	48.78	54.00	-6.29	34.52	9.92	45.51	200	60	Average
5240	102.96	103.99	/	/	34.59	9.89	45.51	200	60	Peak
5240	97.51	98.54	/	/	34.59	9.89	45.51	200	60	Average
5350	52.84	53.82	74.00	-21.16	34.68	9.85	45.51	200	60	Peak
5350	47.70	48.68	54.00	-6.30	34.68	9.85	45.51	200	60	Average

ANTENNA POLARITY & TEST DISTANCE: VERTICAL AT 3 M

FREQ. (MHz)	EMISSION LEVEL (dBuV/m)	READ LEVEL (dBuV)	LIMIT (dBuV/m)	MARGIN (dB)	ANTENNA FACTOR (dB /m)	CABLE LOSS (dB)	PREAMP FACTOR (dB)	ANTENNA HEIGHT (cm)	TABLE ANGLE (Degree)	REMARK
5150	53.84	54.83	74.00	-20.16	34.60	9.92	45.51	100	300	Peak
5150	47.40	48.39	54.00	-6.60	34.60	9.92	45.51	100	300	Average
5240	100.67	101.69	/	/	34.60	9.89	45.51	100	300	Peak
5240	93.84	94.86	/	/	34.60	9.89	45.51	100	300	Average
5350	53.15	54.21	74.00	-20.85	34.60	9.85	45.51	100	300	Peak
5350	47.64	48.70	54.00	-6.36	34.60	9.85	45.51	100	300	Average

REMARKS:

- Emission Level = Read Level+ Antenna Factor + Cable Loss- Preamp Factor
Margin value = Emission level – Limit value.
- 5240MHz: Fundamental frequency.



802.11n (40MHz)

CHANNEL	TX Channel 38	DETECTOR FUNCTION	Peak (PK)
FREQUENCY RANGE	1GHz ~ 40GHz		Average (AV)

ANTENNA POLARITY & TEST DISTANCE: HORIZONTAL AT 3 M

FREQ. (MHz)	EMISSION LEVEL (dBuV/m)	READ LEVEL (dBuV)	LIMIT (dBuV/m)	MARGIN (dB)	ANTENNA FACTOR (dB /m)	CABLE LOSS (dB)	PREAMP FACTOR (dB)	ANTENNA HEIGHT (cm)	TABLE ANGLE (Degree)	REMARK
5150	57.48	58.55	74.00	-16.52	34.52	9.92	45.51	200	60	Peak
5150	50.41	51.48	54.00	-3.59	34.52	9.92	45.51	200	60	Average
5190	100.62	101.67	/	/	34.55	9.91	45.51	200	60	Peak
5190	95.30	96.35	/	/	34.55	9.91	45.51	200	60	Average
5350	54.05	55.03	74.00	-19.95	34.68	9.85	45.51	200	60	Peak
5350	47.49	48.47	54.00	-6.51	34.68	9.85	45.51	200	60	Average

ANTENNA POLARITY & TEST DISTANCE: VERTICAL AT 3 M

FREQ. (MHz)	EMISSION LEVEL (dBuV/m)	READ LEVEL (dBuV)	LIMIT (dBuV/m)	MARGIN (dB)	ANTENNA FACTOR (dB /m)	CABLE LOSS (dB)	PREAMP FACTOR (dB)	ANTENNA HEIGHT (cm)	TABLE ANGLE (Degree)	REMARK
5150	55.37	56.36	74.00	-18.63	34.60	9.92	45.51	100	300	Peak
5150	50.15	51.14	54.00	-3.85	34.60	9.92	45.51	100	300	Average
5190	97.85	98.85	/	/	34.60	9.91	45.51	100	300	Peak
5190	93.90	94.90	/	/	34.60	9.91	45.51	100	300	Average
5350	52.61	53.67	74.00	-21.39	34.60	9.85	45.51	100	300	Peak
5350	47.63	48.69	54.00	-6.37	34.60	9.85	45.51	100	300	Average

REMARKS:

- Emission Level = Read Level+ Antenna Factor + Cable Loss- Preamp Factor
Margin value = Emission level – Limit value.
- 5190MHz: Fundamental frequency.



CHANNEL	TX Channel 46	DETECTOR FUNCTION	Peak (PK)
FREQUENCY RANGE	1GHz ~ 40GHz		Average (AV)

ANTENNA POLARITY & TEST DISTANCE: HORIZONTAL AT 3 M

FREQ. (MHz)	EMISSION LEVEL (dBuV/m)	READ LEVEL (dBuV)	LIMIT (dBuV/m)	MARGIN (dB)	ANTENNA FACTOR (dB /m)	CABLE LOSS (dB)	PREAMP FACTOR (dB)	ANTENNA HEIGHT (cm)	TABLE ANGLE (Degree)	REMARK
5150	52.35	53.42	74.00	-21.65	34.52	9.92	45.51	200	60	Peak
5150	47.24	48.31	54.00	-6.76	34.52	9.92	45.51	200	60	Average
5230	100.37	101.41	/	/	34.58	9.89	45.51	200	60	Peak
5230	93.81	94.85	/	/	34.58	9.89	45.51	200	60	Average
5350	53.02	54.00	74.00	-20.98	34.68	9.85	45.51	200	60	Peak
5350	47.74	48.72	54.00	-6.26	34.68	9.85	45.51	200	60	Average

ANTENNA POLARITY & TEST DISTANCE: VERTICAL AT 3 M

FREQ. (MHz)	EMISSION LEVEL (dBuV/m)	READ LEVEL (dBuV)	LIMIT (dBuV/m)	MARGIN (dB)	ANTENNA FACTOR (dB /m)	CABLE LOSS (dB)	PREAMP FACTOR (dB)	ANTENNA HEIGHT (cm)	TABLE ANGLE (Degree)	REMARK
5150	52.29	53.28	74.00	-21.71	34.60	9.92	45.51	100	300	Peak
5150	49.01	50.00	54.00	-4.99	34.60	9.92	45.51	100	300	Average
5230	97.24	98.26	/	/	34.60	9.89	45.51	100	300	Peak
5230	91.78	92.80	/	/	34.60	9.89	45.51	100	300	Average
5350	51.85	52.91	74.00	-22.15	34.60	9.85	45.51	100	300	Peak
5350	47.85	48.91	54.00	-6.15	34.60	9.85	45.51	100	300	Average

REMARKS:

- Emission Level = Read Level+ Antenna Factor + Cable Loss- Preamp Factor
Margin value = Emission level – Limit value.
- 5230MHz: Fundamental frequency.



802.11ac (20MHz)

CHANNEL	TX Channel 36	DETECTOR FUNCTION	Peak (PK)
FREQUENCY RANGE	1GHz ~ 40GHz		Average (AV)

ANTENNA POLARITY & TEST DISTANCE: HORIZONTAL AT 3 M										
FREQ. (MHz)	EMISSION LEVEL (dBuV/m)	READ LEVEL (dBuV)	LIMIT (dBuV/m)	MARGIN (dB)	ANTENNA FACTOR (dB /m)	CABLE LOSS (dB)	PREAMP FACTOR (dB)	ANTENNA HEIGHT (cm)	TABLE ANGLE (Degree)	REMARK
5150	55.44	56.51	74.00	-18.56	34.52	9.92	45.51	200	60	Peak
5150	49.96	51.03	54.00	-4.04	34.52	9.92	45.51	200	60	Average
5180	105.22	106.28	/	/	34.54	9.91	45.51	200	60	Peak
5180	97.25	98.31	/	/	34.54	9.91	45.51	200	60	Average
5350	53.92	54.90	74.00	-20.08	34.68	9.85	45.51	200	60	Peak
5350	47.19	48.17	54.00	-6.81	34.68	9.85	45.51	200	60	Average

ANTENNA POLARITY & TEST DISTANCE: VERTICAL AT 3 M										
FREQ. (MHz)	EMISSION LEVEL (dBuV/m)	READ LEVEL (dBuV)	LIMIT (dBuV/m)	MARGIN (dB)	ANTENNA FACTOR (dB /m)	CABLE LOSS (dB)	PREAMP FACTOR (dB)	ANTENNA HEIGHT (cm)	TABLE ANGLE (Degree)	REMARK
5150	55.93	56.92	74.00	-18.07	34.60	9.92	45.51	100	300	Peak
5150	50.48	51.47	54.00	-3.52	34.60	9.92	45.51	100	300	Average
5180	104.81	105.81	/	/	34.60	9.91	45.51	100	300	Peak
5180	97.83	98.83	/	/	34.60	9.91	45.51	100	300	Average
5350	55.21	56.27	74.00	-18.79	34.60	9.85	45.51	100	300	Peak
5350	48.21	49.27	54.00	-5.79	34.60	9.85	45.51	100	300	Average

REMARKS:

- Emission Level = Read Level+ Antenna Factor + Cable Loss- Preamp Factor
Margin value = Emission level – Limit value.
- 5180MHz: Fundamental frequency.



CHANNEL	TX Channel 40	DETECTOR FUNCTION	Peak (PK)
FREQUENCY RANGE	1GHz ~ 40GHz		Average (AV)

ANTENNA POLARITY & TEST DISTANCE: HORIZONTAL AT 3 M

FREQ. (MHz)	EMISSION LEVEL (dBuV/m)	READ LEVEL (dBuV)	LIMIT (dBuV/m)	MARGIN (dB)	ANTENNA FACTOR (dB /m)	CABLE LOSS (dB)	PREAMP FACTOR (dB)	ANTENNA HEIGHT (cm)	TABLE ANGLE (Degree)	REMARK
5150	52.78	53.85	74.00	-21.22	34.52	9.92	45.51	200	60	Peak
5150	48.00	49.07	54.00	-6.00	34.52	9.92	45.51	200	60	Average
5200	102.78	103.83	/	/	34.56	9.90	45.51	200	60	Peak
5200	96.17	97.22	/	/	34.56	9.90	45.51	200	60	Average
5350	53.24	54.22	74.00	-20.76	34.68	9.85	45.51	200	60	Peak
5350	47.69	48.67	54.00	-6.31	34.68	9.85	45.51	200	60	Average

ANTENNA POLARITY & TEST DISTANCE: VERTICAL AT 3 M

FREQ. (MHz)	EMISSION LEVEL (dBuV/m)	READ LEVEL (dBuV)	LIMIT (dBuV/m)	MARGIN (dB)	ANTENNA FACTOR (dB /m)	CABLE LOSS (dB)	PREAMP FACTOR (dB)	ANTENNA HEIGHT (cm)	TABLE ANGLE (Degree)	REMARK
5150	52.76	53.75	74.00	-21.24	34.60	9.92	45.51	100	300	Peak
5150	48.35	49.34	54.00	-5.65	34.60	9.92	45.51	100	300	Average
5200	103.45	104.46	/	/	34.60	9.90	45.51	100	300	Peak
5200	96.15	97.16	/	/	34.60	9.90	45.51	100	300	Average
5350	53.21	54.27	74.00	-20.79	34.60	9.85	45.51	100	300	Peak
5350	47.37	48.43	54.00	-6.63	34.60	9.85	45.51	100	300	Average

REMARKS:

- Emission Level = Read Level+ Antenna Factor + Cable Loss- Preamp Factor
Margin value = Emission level – Limit value.
- 5200MHz: Fundamental frequency.



CHANNEL	TX Channel 48	DETECTOR FUNCTION	Peak (PK)
FREQUENCY RANGE	1GHz ~ 40GHz		Average (AV)

ANTENNA POLARITY & TEST DISTANCE: HORIZONTAL AT 3 M

FREQ. (MHz)	EMISSION LEVEL (dBuV/m)	READ LEVEL (dBuV)	LIMIT (dBuV/m)	MARGIN (dB)	ANTENNA FACTOR (dB /m)	CABLE LOSS (dB)	PREAMP FACTOR (dB)	ANTENNA HEIGHT (cm)	TABLE ANGLE (Degree)	REMARK
5150	53.02	54.09	74.00	-20.98	34.52	9.92	45.51	200	60	Peak
5150	47.94	49.01	54.00	-6.06	34.52	9.92	45.51	200	60	Average
5240	101.40	102.43	/	/	34.59	9.89	45.51	200	60	Peak
5240	94.26	95.29	/	/	34.59	9.89	45.51	200	60	Average
5350	52.87	53.85	74.00	-21.13	34.68	9.85	45.51	200	60	Peak
5350	47.60	48.58	54.00	-6.40	34.68	9.85	45.51	200	60	Average

ANTENNA POLARITY & TEST DISTANCE: VERTICAL AT 3 M

FREQ. (MHz)	EMISSION LEVEL (dBuV/m)	READ LEVEL (dBuV)	LIMIT (dBuV/m)	MARGIN (dB)	ANTENNA FACTOR (dB /m)	CABLE LOSS (dB)	PREAMP FACTOR (dB)	ANTENNA HEIGHT (cm)	TABLE ANGLE (Degree)	REMARK
5150	53.59	54.58	74.00	-20.41	34.60	9.92	45.51	100	300	Peak
5150	48.43	49.42	54.00	-5.57	34.60	9.92	45.51	100	300	Average
5240	102.45	103.47	/	/	34.60	9.89	45.51	100	300	Peak
5240	94.34	95.36	/	/	34.60	9.89	45.51	100	300	Average
5350	54.20	55.26	74.00	-19.80	34.60	9.85	45.51	100	300	Peak
5350	47.32	48.38	54.00	-6.68	34.60	9.85	45.51	100	300	Average

REMARKS:

- Emission Level = Read Level+ Antenna Factor + Cable Loss- Preamp Factor
Margin value = Emission level – Limit value.
- 5240MHz: Fundamental frequency.



802.11ac (40MHz)

CHANNEL	TX Channel 38	DETECTOR FUNCTION	Peak (PK)
FREQUENCY RANGE	1GHz ~ 40GHz		Average (AV)

ANTENNA POLARITY & TEST DISTANCE: HORIZONTAL AT 3 M

FREQ. (MHz)	EMISSION LEVEL (dBuV/m)	READ LEVEL (dBuV)	LIMIT (dBuV/m)	MARGIN (dB)	ANTENNA FACTOR (dB /m)	CABLE LOSS (dB)	PREAMP FACTOR (dB)	ANTENNA HEIGHT (cm)	TABLE ANGLE (Degree)	REMARK
5150	57.25	58.32	74.00	-16.75	34.52	9.92	45.51	200	60	Peak
5150	50.85	51.92	54.00	-3.15	34.52	9.92	45.51	200	60	Average
5190	100.04	101.09	/	/	34.55	9.91	45.51	200	60	Peak
5190	91.76	92.81	/	/	34.55	9.91	45.51	200	60	Average
5350	53.21	54.19	74.00	-20.79	34.68	9.85	45.51	200	60	Peak
5350	47.39	48.37	54.00	-6.61	34.68	9.85	45.51	200	60	Average

ANTENNA POLARITY & TEST DISTANCE: VERTICAL AT 3 M

FREQ. (MHz)	EMISSION LEVEL (dBuV/m)	READ LEVEL (dBuV)	LIMIT (dBuV/m)	MARGIN (dB)	ANTENNA FACTOR (dB /m)	CABLE LOSS (dB)	PREAMP FACTOR (dB)	ANTENNA HEIGHT (cm)	TABLE ANGLE (Degree)	REMARK
5150	58.86	59.85	74.00	-15.14	34.60	9.92	45.51	100	300	Peak
5150	50.57	51.56	54.00	-3.43	34.60	9.92	45.51	100	300	Average
5190	98.74	99.74	/	/	34.60	9.91	45.51	100	300	Peak
5190	93.07	94.07	/	/	34.60	9.91	45.51	100	300	Average
5350	53.11	54.17	74.00	-20.89	34.60	9.85	45.51	100	300	Peak
5350	47.47	48.53	54.00	-6.53	34.60	9.85	45.51	100	300	Average

REMARKS:

- Emission Level = Read Level+ Antenna Factor + Cable Loss- Preamp Factor
Margin value = Emission level – Limit value.
- 5190MHz: Fundamental frequency.



CHANNEL	TX Channel 46	DETECTOR FUNCTION	Peak (PK)
FREQUENCY RANGE	1GHz ~ 40GHz		Average (AV)

ANTENNA POLARITY & TEST DISTANCE: HORIZONTAL AT 3 M

FREQ. (MHz)	EMISSION LEVEL (dBuV/m)	READ LEVEL (dBuV)	LIMIT (dBuV/m)	MARGIN (dB)	ANTENNA FACTOR (dB /m)	CABLE LOSS (dB)	PREAMP FACTOR (dB)	ANTENNA HEIGHT (cm)	TABLE ANGLE (Degree)	REMARK
5150	51.98	53.05	74.00	-22.02	34.52	9.92	45.51	200	60	Peak
5150	48.95	50.02	54.00	-5.05	34.52	9.92	45.51	200	60	Average
5230	97.90	98.94	/	/	34.58	9.89	45.51	200	60	Peak
5230	90.87	91.91	/	/	34.58	9.89	45.51	200	60	Average
5350	52.70	53.68	74.00	-21.30	34.68	9.85	45.51	200	60	Peak
5350	47.46	48.44	54.00	-6.54	34.68	9.85	45.51	200	60	Average

ANTENNA POLARITY & TEST DISTANCE: VERTICAL AT 3 M

FREQ. (MHz)	EMISSION LEVEL (dBuV/m)	READ LEVEL (dBuV)	LIMIT (dBuV/m)	MARGIN (dB)	ANTENNA FACTOR (dB /m)	CABLE LOSS (dB)	PREAMP FACTOR (dB)	ANTENNA HEIGHT (cm)	TABLE ANGLE (Degree)	REMARK
5150	53.30	54.29	74.00	-20.70	34.60	9.92	45.51	100	300	Peak
5150	48.76	49.75	54.00	-5.24	34.60	9.92	45.51	100	300	Average
5230	99.11	100.13	/	/	34.60	9.89	45.51	100	300	Peak
5230	91.91	92.93	/	/	34.60	9.89	45.51	100	300	Average
5350	53.38	54.44	74.00	-20.62	34.60	9.85	45.51	100	300	Peak
5350	48.51	49.57	54.00	-5.49	34.60	9.85	45.51	100	300	Average

REMARKS:

- Emission Level = Read Level+ Antenna Factor + Cable Loss- Preamp Factor
Margin value = Emission level – Limit value.
- 5230MHz: Fundamental frequency.



802.11ac (80MHz)

CHANNEL	TX Channel 42	DETECTOR FUNCTION	Peak (PK)
FREQUENCY RANGE	1GHz ~ 40GHz		Average (AV)

ANTENNA POLARITY & TEST DISTANCE: HORIZONTAL AT 3 M

FREQ. (MHz)	EMISSION LEVEL (dBuV/m)	READ LEVEL (dBuV)	LIMIT (dBuV/m)	MARGIN (dB)	ANTENNA FACTOR (dB /m)	CABLE LOSS (dB)	PREAMP FACTOR (dB)	ANTENNA HEIGHT (cm)	TABLE ANGLE (Degree)	REMARK
5150	53.74	54.81	74.00	-20.26	34.52	9.92	45.51	100	20	Peak
5150	49.66	50.73	54.00	-4.34	34.52	9.92	45.51	100	20	Average
5210	91.08	92.12	/	/	34.57	9.90	45.51	100	20	Peak
5210	86.23	87.27	/	/	34.57	9.90	45.51	100	20	Average
5350	52.93	53.91	74.00	-21.07	34.68	9.85	45.51	100	20	Peak
5350	47.11	48.09	54.00	-6.89	34.68	9.85	45.51	100	20	Average

ANTENNA POLARITY & TEST DISTANCE: VERTICAL AT 3 M

FREQ. (MHz)	EMISSION LEVEL (dBuV/m)	READ LEVEL (dBuV)	LIMIT (dBuV/m)	MARGIN (dB)	ANTENNA FACTOR (dB /m)	CABLE LOSS (dB)	PREAMP FACTOR (dB)	ANTENNA HEIGHT (cm)	TABLE ANGLE (Degree)	REMARK
5150	54.27	55.26	74.00	-19.73	34.60	9.92	45.51	100	305	Peak
5150	50.15	51.14	54.00	-3.85	34.60	9.92	45.51	100	305	Average
5210	93.57	94.58	/	/	34.60	9.90	45.51	100	305	Peak
5210	88.66	89.67	/	/	34.60	9.90	45.51	100	305	Average
5350	52.66	53.72	74.00	-21.34	34.60	9.85	45.51	100	305	Peak
5350	47.43	48.49	54.00	-6.57	34.60	9.85	45.51	100	305	Average

REMARKS:

- Emission Level = Read Level+ Antenna Factor + Cable Loss- Preamp Factor
Margin value = Emission level – Limit value.
- 5210MHz: Fundamental frequency.



Worst case harmonic:

802.11n (40MHz)

CHANNEL	TX Channel 38	DETECTOR FUNCTION	Peak (PK)
FREQUENCY RANGE	1GHz ~ 40GHz		Average (AV)

ANTENNA POLARITY & TEST DISTANCE: HORIZONTAL AT 3 M

	Freq	Level	Read Level	Limit Line	Over Limit	Factor	Remark	Pol/Phase
	MHz	dBuV/m	dBuV	dBuV/m	dB	dB/m		
1	10380.000	52.53	45.65	74.00	-21.47	6.88	Peak	Horizontal
2	10380.000	42.74	35.86	54.00	-11.26	6.88	Average	Horizontal
3	PK15569.000	54.18	41.33	74.00	-19.82	12.85	Peak	Horizontal
4	PP15569.000	46.18	33.33	54.00	-7.82	12.85	Average	Horizontal

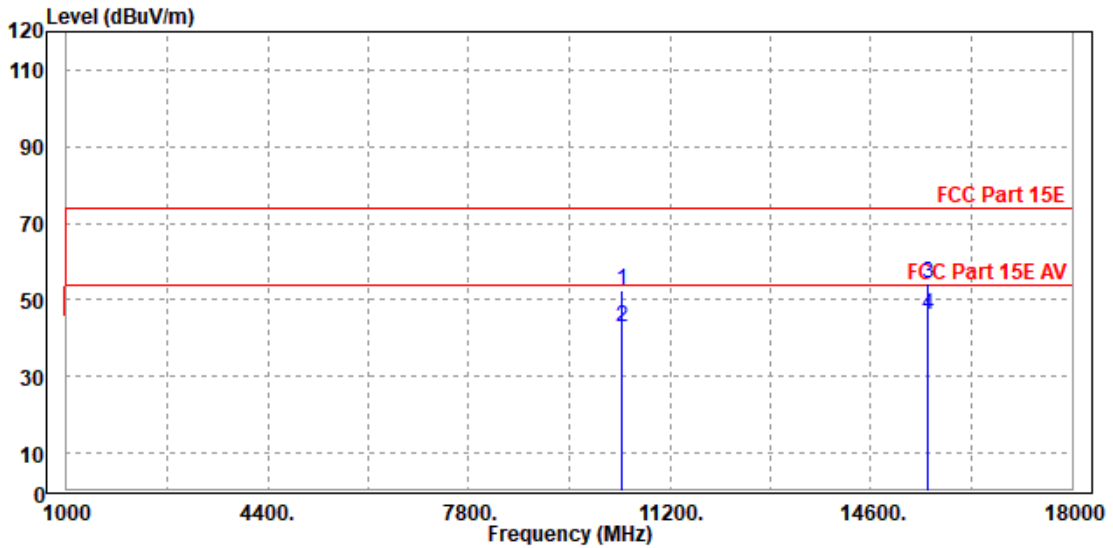



ANTENNA POLARITY & TEST DISTANCE: VERTICAL AT 3 M

	Freq	Level	Read Level	Limit Line	Over Limit	Factor	Remark	Pol/Phase
	MHz	dBuV/m	dBuV	dBuV/m	dB	dB/m		
1	10384.000	52.44	44.41	74.00	-21.56	8.03	Peak	Vertical
2	10384.000	43.72	35.69	54.00	-10.28	8.03	Average	Vertical
3	PK15570.000	53.78	41.92	74.00	-20.22	11.86	Peak	Vertical
4	PP15570.000	44.53	32.67	54.00	-9.47	11.86	Average	Vertical

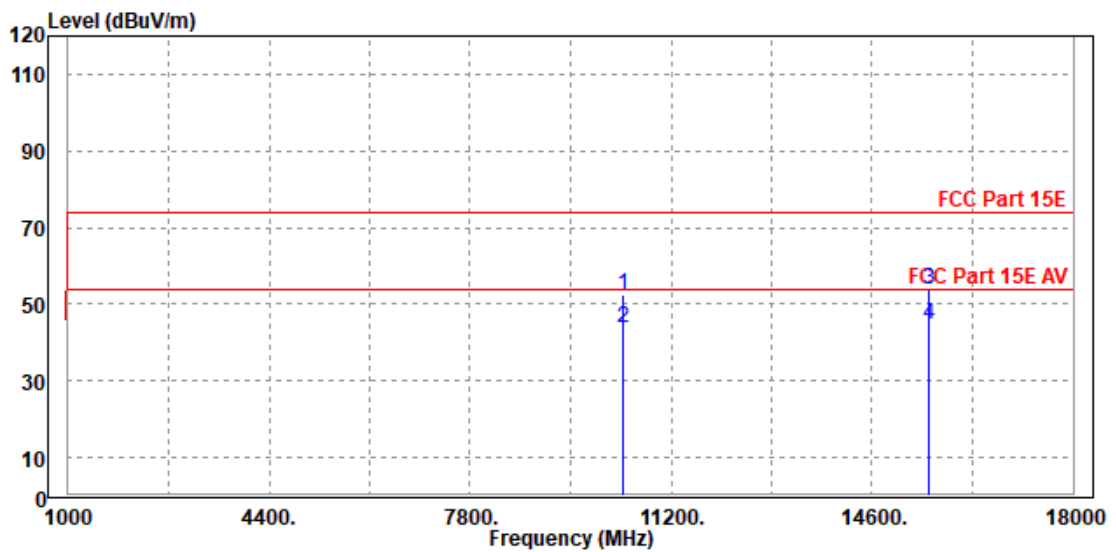

REMARKS:

- Emission Level = Read Level+ Antenna Factor + Cable Loss- Preamp Factor
Margin value = Emission level – Limit value.
- 5190MHz: Fundamental frequency.
- For frequency above 18GHz, the emission was tested 20db below the limit so the data not recorded in the sheet.



Band 2

802.11a

CHANNEL	TX Channel 52	DETECTOR FUNCTION	Peak (PK)
FREQUENCY RANGE	1GHz ~ 40GHz		Average (AV)

ANTENNA POLARITY & TEST DISTANCE: HORIZONTAL AT 3 M

FREQ. (MHz)	EMISSION LEVEL (dBuV/m)	READ LEVEL (dBuV)	LIMIT (dBuV/m)	MARGIN (dB)	ANTENNA FACTOR (dB /m)	CABLE LOSS (dB)	PREAMP FACTOR (dB)	ANTENNA HEIGHT (cm)	TABLE ANGLE (Degree)	REMARK
5150	53.26	54.33	74.00	-20.74	34.52	9.92	45.51	100	35	Peak
5150	48.13	49.20	54.00	-5.87	34.52	9.92	45.51	100	35	Average
5260	102.46	103.48	/	/	34.61	9.88	45.51	100	35	Peak
5260	95.94	96.96	/	/	34.61	9.88	45.51	100	35	Average
5350	52.17	53.15	74.00	-21.83	34.68	9.85	45.51	100	35	Peak
5350	47.04	48.02	54.00	-6.96	34.68	9.85	45.51	100	35	Average

ANTENNA POLARITY & TEST DISTANCE: VERTICAL AT 3 M

FREQ. (MHz)	EMISSION LEVEL (dBuV/m)	READ LEVEL (dBuV)	LIMIT (dBuV/m)	MARGIN (dB)	ANTENNA FACTOR (dB /m)	CABLE LOSS (dB)	PREAMP FACTOR (dB)	ANTENNA HEIGHT (cm)	TABLE ANGLE (Degree)	REMARK
5150	54.89	55.88	74.00	-19.11	34.60	9.92	45.51	100	300	Peak
5150	48.91	49.90	54.00	-5.09	34.60	9.92	45.51	100	300	Average
5260	103.52	104.55	/	/	34.60	9.88	45.51	100	300	Peak
5260	96.17	97.20	/	/	34.60	9.88	45.51	100	300	Average
5350	54.85	55.91	74.00	-19.15	34.60	9.85	45.51	100	300	Peak
5350	48.04	49.10	54.00	-5.96	34.60	9.85	45.51	100	300	Average

REMARKS:

- Emission Level = Read Level+ Antenna Factor + Cable Loss- Preamp Factor
Margin value = Emission level – Limit value.
- 5260MHz: Fundamental frequency.



CHANNEL	TX Channel 60	DETECTOR FUNCTION	Peak (PK)
FREQUENCY RANGE	1GHz ~ 40GHz		Average (AV)

ANTENNA POLARITY & TEST DISTANCE: HORIZONTAL AT 3 M

FREQ. (MHz)	EMISSION LEVEL (dBuV/m)	READ LEVEL (dBuV)	LIMIT (dBuV/m)	MARGIN (dB)	ANTENNA FACTOR (dB /m)	CABLE LOSS (dB)	PREAMP FACTOR (dB)	ANTENNA HEIGHT (cm)	TABLE ANGLE (Degree)	REMARK
5150	53.22	54.29	74.00	-20.78	34.52	9.92	45.51	100	35	Peak
5150	48.96	50.03	54.00	-5.04	34.52	9.92	45.51	100	35	Average
5300	102.11	103.11	/	/	34.64	9.87	45.51	100	35	Peak
5300	94.89	95.89	/	/	34.64	9.87	45.51	100	35	Average
5350	52.83	53.81	74.00	-21.17	34.68	9.85	45.51	100	35	Peak
5350	48.11	49.09	54.00	-5.89	34.68	9.85	45.51	100	35	Average

ANTENNA POLARITY & TEST DISTANCE: VERTICAL AT 3 M

FREQ. (MHz)	EMISSION LEVEL (dBuV/m)	READ LEVEL (dBuV)	LIMIT (dBuV/m)	MARGIN (dB)	ANTENNA FACTOR (dB /m)	CABLE LOSS (dB)	PREAMP FACTOR (dB)	ANTENNA HEIGHT (cm)	TABLE ANGLE (Degree)	REMARK
5150	54.17	55.16	74.00	-19.83	34.60	9.92	45.51	100	300	Peak
5150	49.18	50.17	54.00	-4.82	34.60	9.92	45.51	100	300	Average
5300	102.87	103.91	/	/	34.60	9.87	45.51	100	300	Peak
5300	97.88	98.92	/	/	34.60	9.87	45.51	100	300	Average
5350	53.83	54.89	74.00	-20.17	34.60	9.85	45.51	100	300	Peak
5350	47.97	49.03	54.00	-6.03	34.60	9.85	45.51	100	300	Average

REMARKS:

- Emission Level = Read Level+ Antenna Factor + Cable Loss- Preamp Factor
Margin value = Emission level – Limit value.
- 5300MHz: Fundamental frequency.



CHANNEL	TX Channel 64	DETECTOR FUNCTION	Peak (PK)
FREQUENCY RANGE	1GHz ~ 40GHz		Average (AV)

ANTENNA POLARITY & TEST DISTANCE: HORIZONTAL AT 3 M

FREQ. (MHz)	EMISSION LEVEL (dBuV/m)	READ LEVEL (dBuV)	LIMIT (dBuV/m)	MARGIN (dB)	ANTENNA FACTOR (dB /m)	CABLE LOSS (dB)	PREAMP FACTOR (dB)	ANTENNA HEIGHT (cm)	TABLE ANGLE (Degree)	REMARK
5150	54.08	55.15	74.00	-19.92	34.52	9.92	45.51	100	35	Peak
5150	48.96	50.03	54.00	-5.04	34.52	9.92	45.51	100	35	Average
5320	102.60	103.59	/	/	34.66	9.86	45.51	100	35	Peak
5320	94.90	95.89	/	/	34.66	9.86	45.51	100	35	Average
5350	54.31	55.29	74.00	-19.69	34.68	9.85	45.51	100	35	Peak
5350	49.42	50.40	54.00	-4.58	34.68	9.85	45.51	100	35	Average

ANTENNA POLARITY & TEST DISTANCE: VERTICAL AT 3 M

FREQ. (MHz)	EMISSION LEVEL (dBuV/m)	READ LEVEL (dBuV)	LIMIT (dBuV/m)	MARGIN (dB)	ANTENNA FACTOR (dB /m)	CABLE LOSS (dB)	PREAMP FACTOR (dB)	ANTENNA HEIGHT (cm)	TABLE ANGLE (Degree)	REMARK
5150	53.72	54.71	74.00	-20.28	34.60	9.92	45.51	100	300	Peak
5150	48.88	49.87	54.00	-5.12	34.60	9.92	45.51	100	300	Average
5320	101.55	102.60	/	/	34.60	9.86	45.51	100	300	Peak
5320	96.10	97.15	/	/	34.60	9.86	45.51	100	300	Average
5350	53.65	54.71	74.00	-20.35	34.60	9.85	45.51	100	300	Peak
5350	49.55	50.61	54.00	-4.45	34.60	9.85	45.51	100	300	Average

REMARKS:

- Emission Level = Read Level+ Antenna Factor + Cable Loss- Preamp Factor
Margin value = Emission level – Limit value.
- 5320MHz: Fundamental frequency.



802.11n (20MHz)

CHANNEL	TX Channel 52	DETECTOR FUNCTION	Peak (PK)
FREQUENCY RANGE	1GHz ~ 40GHz		Average (AV)

ANTENNA POLARITY & TEST DISTANCE: HORIZONTAL AT 3 M										
FREQ. (MHz)	EMISSION LEVEL (dBuV/m)	READ LEVEL (dBuV)	LIMIT (dBuV/m)	MARGIN (dB)	ANTENNA FACTOR (dB /m)	CABLE LOSS (dB)	PREAMP FACTOR (dB)	ANTENNA HEIGHT (cm)	TABLE ANGLE (Degree)	REMARK
5150	53.36	54.43	74.00	-20.64	34.52	9.92	45.51	100	35	Peak
5150	48.30	49.37	54.00	-5.70	34.52	9.92	45.51	100	35	Average
5260	102.51	103.53	/	/	34.61	9.88	45.51	100	35	Peak
5260	95.36	96.38	/	/	34.61	9.88	45.51	100	35	Average
5350	54.15	55.13	74.00	-19.85	34.68	9.85	45.51	100	35	Peak
5350	47.49	48.47	54.00	-6.51	34.68	9.85	45.51	100	35	Average

ANTENNA POLARITY & TEST DISTANCE: VERTICAL AT 3 M										
FREQ. (MHz)	EMISSION LEVEL (dBuV/m)	READ LEVEL (dBuV)	LIMIT (dBuV/m)	MARGIN (dB)	ANTENNA FACTOR (dB /m)	CABLE LOSS (dB)	PREAMP FACTOR (dB)	ANTENNA HEIGHT (cm)	TABLE ANGLE (Degree)	REMARK
5150	53.78	54.77	74.00	-20.22	34.60	9.92	45.51	100	300	Peak
5150	48.12	49.11	54.00	-5.88	34.60	9.92	45.51	100	300	Average
5260	103.24	104.27	/	/	34.60	9.88	45.51	100	300	Peak
5260	95.48	96.51	/	/	34.60	9.88	45.51	100	300	Average
5350	52.91	53.97	74.00	-21.09	34.60	9.85	45.51	100	300	Peak
5350	47.16	48.22	54.00	-6.84	34.60	9.85	45.51	100	300	Average

REMARKS:

- Emission Level = Read Level+ Antenna Factor + Cable Loss- Preamp Factor
Margin value = Emission level – Limit value.
- 5260MHz: Fundamental frequency.



CHANNEL	TX Channel 60	DETECTOR FUNCTION	Peak (PK)
FREQUENCY RANGE	1GHz ~ 40GHz		Average (AV)

ANTENNA POLARITY & TEST DISTANCE: HORIZONTAL AT 3 M

FREQ. (MHz)	EMISSION LEVEL (dBuV/m)	READ LEVEL (dBuV)	LIMIT (dBuV/m)	MARGIN (dB)	ANTENNA FACTOR (dB /m)	CABLE LOSS (dB)	PREAMP FACTOR (dB)	ANTENNA HEIGHT (cm)	TABLE ANGLE (Degree)	REMARK
5150	53.09	54.16	74.00	-20.91	34.52	9.92	45.51	100	35	Peak
5150	47.63	48.70	54.00	-6.37	34.52	9.92	45.51	100	35	Average
5300	100.74	101.74	/	/	34.64	9.87	45.51	100	35	Peak
5300	94.34	95.34	/	/	34.64	9.87	45.51	100	35	Average
5350	53.40	54.38	74.00	-20.60	34.68	9.85	45.51	100	35	Peak
5350	47.87	48.85	54.00	-6.13	34.68	9.85	45.51	100	35	Average

ANTENNA POLARITY & TEST DISTANCE: VERTICAL AT 3 M

FREQ. (MHz)	EMISSION LEVEL (dBuV/m)	READ LEVEL (dBuV)	LIMIT (dBuV/m)	MARGIN (dB)	ANTENNA FACTOR (dB /m)	CABLE LOSS (dB)	PREAMP FACTOR (dB)	ANTENNA HEIGHT (cm)	TABLE ANGLE (Degree)	REMARK
5150	52.94	53.93	74.00	-21.06	34.60	9.92	45.51	100	300	Peak
5150	47.79	48.78	54.00	-6.21	34.60	9.92	45.51	100	300	Average
5300	101.91	102.95	/	/	34.60	9.87	45.51	100	300	Peak
5300	95.12	96.16	/	/	34.60	9.87	45.51	100	300	Average
5350	54.53	55.59	74.00	-19.47	34.60	9.85	45.51	100	300	Peak
5350	47.19	48.25	54.00	-6.81	34.60	9.85	45.51	100	300	Average

REMARKS:

- Emission Level = Read Level+ Antenna Factor + Cable Loss- Preamp Factor
Margin value = Emission level – Limit value.
- 5300MHz: Fundamental frequency.



CHANNEL	TX Channel 64	DETECTOR FUNCTION	Peak (PK)
FREQUENCY RANGE	1GHz ~ 40GHz		Average (AV)

ANTENNA POLARITY & TEST DISTANCE: HORIZONTAL AT 3 M

FREQ. (MHz)	EMISSION LEVEL (dBuV/m)	READ LEVEL (dBuV)	LIMIT (dBuV/m)	MARGIN (dB)	ANTENNA FACTOR (dB /m)	CABLE LOSS (dB)	PREAMP FACTOR (dB)	ANTENNA HEIGHT (cm)	TABLE ANGLE (Degree)	REMARK
5150	53.96	55.03	74.00	-20.04	34.52	9.92	45.51	100	35	Peak
5150	49.08	50.15	54.00	-4.92	34.52	9.92	45.51	100	35	Average
5320	101.19	102.18	/	/	34.66	9.86	45.51	100	35	Peak
5320	94.11	95.10	/	/	34.66	9.86	45.51	100	35	Average
5350	56.72	57.70	74.00	-17.28	34.68	9.85	45.51	100	35	Peak
5350	50.16	51.14	54.00	-3.84	34.68	9.85	45.51	100	35	Average

ANTENNA POLARITY & TEST DISTANCE: VERTICAL AT 3 M

FREQ. (MHz)	EMISSION LEVEL (dBuV/m)	READ LEVEL (dBuV)	LIMIT (dBuV/m)	MARGIN (dB)	ANTENNA FACTOR (dB /m)	CABLE LOSS (dB)	PREAMP FACTOR (dB)	ANTENNA HEIGHT (cm)	TABLE ANGLE (Degree)	REMARK
5150	51.41	52.40	74.00	-22.59	34.60	9.92	45.51	100	300	Peak
5150	48.36	49.35	54.00	-5.64	34.60	9.92	45.51	100	300	Average
5320	101.68	102.73	/	/	34.60	9.86	45.51	100	300	Peak
5320	94.68	95.73	/	/	34.60	9.86	45.51	100	300	Average
5350	55.18	56.24	74.00	-18.82	34.60	9.85	45.51	100	300	Peak
5350	50.29	51.35	54.00	-3.71	34.60	9.85	45.51	100	300	Average

REMARKS:

- Emission Level = Read Level+ Antenna Factor + Cable Loss- Preamp Factor
Margin value = Emission level – Limit value.
- 5320MHz: Fundamental frequency.



802.11n (40MHz)

CHANNEL	TX Channel 54	DETECTOR FUNCTION	Peak (PK)
FREQUENCY RANGE	1GHz ~ 40GHz		Average (AV)

ANTENNA POLARITY & TEST DISTANCE: HORIZONTAL AT 3 M

FREQ. (MHz)	EMISSION LEVEL (dBuV/m)	READ LEVEL (dBuV)	LIMIT (dBuV/m)	MARGIN (dB)	ANTENNA FACTOR (dB /m)	CABLE LOSS (dB)	PREAMP FACTOR (dB)	ANTENNA HEIGHT (cm)	TABLE ANGLE (Degree)	REMARK
5150	53.04	54.11	74.00	-20.96	34.52	9.92	45.51	100	35	Peak
5150	48.74	49.81	54.00	-5.26	34.52	9.92	45.51	100	35	Average
5270	99.68	100.69	/	/	34.62	9.88	45.51	100	35	Peak
5270	93.60	94.61	/	/	34.62	9.88	45.51	100	35	Average
5350	53.04	54.02	74.00	-20.96	34.68	9.85	45.51	100	35	Peak
5350	47.72	48.70	54.00	-6.28	34.68	9.85	45.51	100	35	Average

ANTENNA POLARITY & TEST DISTANCE: VERTICAL AT 3 M

FREQ. (MHz)	EMISSION LEVEL (dBuV/m)	READ LEVEL (dBuV)	LIMIT (dBuV/m)	MARGIN (dB)	ANTENNA FACTOR (dB /m)	CABLE LOSS (dB)	PREAMP FACTOR (dB)	ANTENNA HEIGHT (cm)	TABLE ANGLE (Degree)	REMARK
5150	53.42	54.41	74.00	-20.58	34.60	9.92	45.51	100	300	Peak
5150	48.25	49.24	54.00	-5.75	34.60	9.92	45.51	100	300	Average
5270	98.62	99.65	/	/	34.60	9.88	45.51	100	300	Peak
5270	93.31	94.34	/	/	34.60	9.88	45.51	100	300	Average
5350	54.20	55.26	74.00	-19.80	34.60	9.85	45.51	100	300	Peak
5350	48.49	49.55	54.00	-5.51	34.60	9.85	45.51	100	300	Average

REMARKS:

- Emission Level = Read Level+ Antenna Factor + Cable Loss- Preamp Factor
Margin value = Emission level – Limit value.
- 5270MHz: Fundamental frequency.



CHANNEL	TX Channel 62	DETECTOR FUNCTION	Peak (PK)
FREQUENCY RANGE	1GHz ~ 40GHz		Average (AV)

ANTENNA POLARITY & TEST DISTANCE: HORIZONTAL AT 3 M

FREQ. (MHz)	EMISSION LEVEL (dBuV/m)	READ LEVEL (dBuV)	LIMIT (dBuV/m)	MARGIN (dB)	ANTENNA FACTOR (dB /m)	CABLE LOSS (dB)	PREAMP FACTOR (dB)	ANTENNA HEIGHT (cm)	TABLE ANGLE (Degree)	REMARK
5150	53.70	54.77	74.00	-20.30	34.52	9.92	45.51	115	37	Peak
5150	47.31	48.38	54.00	-6.69	34.52	9.92	45.51	115	37	Average
5310	98.76	99.76	/	/	34.65	9.86	45.51	115	37	Peak
5310	93.38	94.38	/	/	34.65	9.86	45.51	115	37	Average
5350	56.22	57.20	74.00	-17.78	34.68	9.85	45.51	115	37	Peak
5350	50.78	51.76	54.00	-3.22	34.68	9.85	45.51	115	37	Average

ANTENNA POLARITY & TEST DISTANCE: VERTICAL AT 3 M

FREQ. (MHz)	EMISSION LEVEL (dBuV/m)	READ LEVEL (dBuV)	LIMIT (dBuV/m)	MARGIN (dB)	ANTENNA FACTOR (dB /m)	CABLE LOSS (dB)	PREAMP FACTOR (dB)	ANTENNA HEIGHT (cm)	TABLE ANGLE (Degree)	REMARK
5150	53.41	54.40	74.00	-20.59	34.60	9.92	45.51	100	350	Peak
5150	47.58	48.57	54.00	-6.42	34.60	9.92	45.51	100	350	Average
5310	97.98	99.03	/	/	34.60	9.86	45.51	100	350	Peak
5310	92.46	93.51	/	/	34.60	9.86	45.51	100	350	Average
5350	56.80	57.86	74.00	-17.20	34.60	9.85	45.51	100	350	Peak
5350	50.28	51.34	54.00	-3.72	34.60	9.85	45.51	100	350	Average

REMARKS:

- Emission Level = Read Level+ Antenna Factor + Cable Loss- Preamp Factor
Margin value = Emission level – Limit value.
- 5310MHz: Fundamental frequency.



802.11ac (20MHz)

CHANNEL	TX Channel 52	DETECTOR FUNCTION	Peak (PK)
FREQUENCY RANGE	1GHz ~ 40GHz		Average (AV)

ANTENNA POLARITY & TEST DISTANCE: HORIZONTAL AT 3 M										
FREQ. (MHz)	EMISSION LEVEL (dBuV/m)	READ LEVEL (dBuV)	LIMIT (dBuV/m)	MARGIN (dB)	ANTENNA FACTOR (dB /m)	CABLE LOSS (dB)	PREAMP FACTOR (dB)	ANTENNA HEIGHT (cm)	TABLE ANGLE (Degree)	REMARK
5150	54.39	55.46	74.00	-19.61	34.52	9.92	45.51	115	37	Peak
5150	50.04	51.11	54.00	-3.96	34.52	9.92	45.51	115	37	Average
5260	104.18	105.20	/	/	34.61	9.88	45.51	115	37	Peak
5260	99.50	100.52	/	/	34.61	9.88	45.51	115	37	Average
5350	53.18	54.16	74.00	-20.82	34.68	9.85	45.51	115	37	Peak
5350	49.21	50.19	54.00	-4.79	34.68	9.85	45.51	115	37	Average

ANTENNA POLARITY & TEST DISTANCE: VERTICAL AT 3 M										
FREQ. (MHz)	EMISSION LEVEL (dBuV/m)	READ LEVEL (dBuV)	LIMIT (dBuV/m)	MARGIN (dB)	ANTENNA FACTOR (dB /m)	CABLE LOSS (dB)	PREAMP FACTOR (dB)	ANTENNA HEIGHT (cm)	TABLE ANGLE (Degree)	REMARK
5150	54.38	55.37	74.00	-19.62	34.60	9.92	45.51	100	350	Peak
5150	49.66	50.65	54.00	-4.34	34.60	9.92	45.51	100	350	Average
5260	103.56	104.59	/	/	34.60	9.88	45.51	100	350	Peak
5260	97.87	98.90	/	/	34.60	9.88	45.51	100	350	Average
5350	56.07	57.13	74.00	-17.93	34.60	9.85	45.51	100	350	Peak
5350	49.12	50.18	54.00	-4.88	34.60	9.85	45.51	100	350	Average

REMARKS:

- Emission Level = Read Level+ Antenna Factor + Cable Loss- Preamp Factor
Margin value = Emission level – Limit value.
- 5260MHz: Fundamental frequency.



CHANNEL	TX Channel 60	DETECTOR FUNCTION	Peak (PK)
FREQUENCY RANGE	1GHz ~ 40GHz		Average (AV)

ANTENNA POLARITY & TEST DISTANCE: HORIZONTAL AT 3 M										
FREQ. (MHz)	EMISSION LEVEL (dBuV/m)	READ LEVEL (dBuV)	LIMIT (dBuV/m)	MARGIN (dB)	ANTENNA FACTOR (dB /m)	CABLE LOSS (dB)	PREAMP FACTOR (dB)	ANTENNA HEIGHT (cm)	TABLE ANGLE (Degree)	REMARK
5150	53.81	54.88	74.00	-20.19	34.52	9.92	45.51	115	37	Peak
5150	50.11	51.18	54.00	-3.89	34.52	9.92	45.51	115	37	Average
5300	103.77	104.77	/	/	34.64	9.87	45.51	115	37	Peak
5300	98.35	99.35	/	/	34.64	9.87	45.51	115	37	Average
5350	54.28	55.26	74.00	-19.72	34.68	9.85	45.51	115	37	Peak
5350	48.98	49.96	54.00	-5.02	34.68	9.85	45.51	115	37	Average

ANTENNA POLARITY & TEST DISTANCE: VERTICAL AT 3 M										
FREQ. (MHz)	EMISSION LEVEL (dBuV/m)	READ LEVEL (dBuV)	LIMIT (dBuV/m)	MARGIN (dB)	ANTENNA FACTOR (dB /m)	CABLE LOSS (dB)	PREAMP FACTOR (dB)	ANTENNA HEIGHT (cm)	TABLE ANGLE (Degree)	REMARK
5150	54.16	55.15	74.00	-19.84	34.60	9.92	45.51	100	350	Peak
5150	49.27	50.26	54.00	-4.73	34.60	9.92	45.51	100	350	Average
5300	103.40	104.44	/	/	34.60	9.87	45.51	100	350	Peak
5300	97.52	98.56	/	/	34.60	9.87	45.51	100	350	Average
5350	55.19	56.25	74.00	-18.81	34.60	9.85	45.51	100	350	Peak
5350	49.32	50.38	54.00	-4.68	34.60	9.85	45.51	100	350	Average

REMARKS:

- Emission Level = Read Level+ Antenna Factor + Cable Loss- Preamp Factor
Margin value = Emission level – Limit value.
- 5300MHz: Fundamental frequency.



CHANNEL	TX Channel 64	DETECTOR FUNCTION	Peak (PK)
FREQUENCY RANGE	1GHz ~ 40GHz		Average (AV)

ANTENNA POLARITY & TEST DISTANCE: HORIZONTAL AT 3 M

FREQ. (MHz)	EMISSION LEVEL (dBuV/m)	READ LEVEL (dBuV)	LIMIT (dBuV/m)	MARGIN (dB)	ANTENNA FACTOR (dB /m)	CABLE LOSS (dB)	PREAMP FACTOR (dB)	ANTENNA HEIGHT (cm)	TABLE ANGLE (Degree)	REMARK
5150	54.42	55.49	74.00	-19.58	34.52	9.92	45.51	115	37	Peak
5150	47.30	48.37	54.00	-6.70	34.52	9.92	45.51	115	37	Average
5320	102.39	103.38	/	/	34.66	9.86	45.51	115	37	Peak
5320	95.61	96.60	/	/	34.66	9.86	45.51	115	37	Average
5350	59.07	60.05	74.00	-14.93	34.68	9.85	45.51	115	37	Peak
5350	49.96	50.94	54.00	-4.04	34.68	9.85	45.51	115	37	Average

ANTENNA POLARITY & TEST DISTANCE: VERTICAL AT 3 M

FREQ. (MHz)	EMISSION LEVEL (dBuV/m)	READ LEVEL (dBuV)	LIMIT (dBuV/m)	MARGIN (dB)	ANTENNA FACTOR (dB /m)	CABLE LOSS (dB)	PREAMP FACTOR (dB)	ANTENNA HEIGHT (cm)	TABLE ANGLE (Degree)	REMARK
5150	54.83	55.82	74.00	-19.17	34.60	9.92	45.51	100	350	Peak
5150	47.40	48.39	54.00	-6.60	34.60	9.92	45.51	100	350	Average
5320	101.74	102.79	/	/	34.60	9.86	45.51	100	350	Peak
5320	94.80	95.85	/	/	34.60	9.86	45.51	100	350	Average
5350	57.42	58.48	74.00	-16.58	34.60	9.85	45.51	100	350	Peak
5350	50.69	51.75	54.00	-3.31	34.60	9.85	45.51	100	350	Average

REMARKS:

- Emission Level = Read Level+ Antenna Factor + Cable Loss- Preamp Factor
Margin value = Emission level – Limit value.
- 5320MHz: Fundamental frequency.



802.11ac (40MHz)

CHANNEL	TX Channel 54	DETECTOR FUNCTION	Peak (PK)
FREQUENCY RANGE	1GHz ~ 40GHz		Average (AV)

ANTENNA POLARITY & TEST DISTANCE: HORIZONTAL AT 3 M

FREQ. (MHz)	EMISSION LEVEL (dBuV/m)	READ LEVEL (dBuV)	LIMIT (dBuV/m)	MARGIN (dB)	ANTENNA FACTOR (dB /m)	CABLE LOSS (dB)	PREAMP FACTOR (dB)	ANTENNA HEIGHT (cm)	TABLE ANGLE (Degree)	REMARK
5150	53.02	54.09	74.00	-20.98	34.52	9.92	45.51	115	37	Peak
5150	48.01	49.08	54.00	-5.99	34.52	9.92	45.51	115	37	Average
5270	98.25	99.26	/	/	34.62	9.88	45.51	115	37	Peak
5270	93.74	94.75	/	/	34.62	9.88	45.51	115	37	Average
5350	53.19	54.17	74.00	-20.81	34.68	9.85	45.51	115	37	Peak
5350	48.31	49.29	54.00	-5.69	34.68	9.85	45.51	115	37	Average

ANTENNA POLARITY & TEST DISTANCE: VERTICAL AT 3 M

FREQ. (MHz)	EMISSION LEVEL (dBuV/m)	READ LEVEL (dBuV)	LIMIT (dBuV/m)	MARGIN (dB)	ANTENNA FACTOR (dB /m)	CABLE LOSS (dB)	PREAMP FACTOR (dB)	ANTENNA HEIGHT (cm)	TABLE ANGLE (Degree)	REMARK
5150	53.47	54.46	74.00	-20.53	34.60	9.92	45.51	100	350	Peak
5150	48.04	49.03	54.00	-5.96	34.60	9.92	45.51	100	350	Average
5270	97.66	98.69	/	/	34.60	9.88	45.51	100	350	Peak
5270	93.39	94.42	/	/	34.60	9.88	45.51	100	350	Average
5350	53.67	54.73	74.00	-20.33	34.60	9.85	45.51	100	350	Peak
5350	47.81	48.87	54.00	-6.19	34.60	9.85	45.51	100	350	Average

REMARKS:

- Emission Level = Read Level+ Antenna Factor + Cable Loss- Preamp Factor
Margin value = Emission level – Limit value.
- 5270MHz: Fundamental frequency.



CHANNEL	TX Channel 62	DETECTOR FUNCTION	Peak (PK)
FREQUENCY RANGE	1GHz ~ 40GHz		Average (AV)

ANTENNA POLARITY & TEST DISTANCE: HORIZONTAL AT 3 M

FREQ. (MHz)	EMISSION LEVEL (dBuV/m)	READ LEVEL (dBuV)	LIMIT (dBuV/m)	MARGIN (dB)	ANTENNA FACTOR (dB /m)	CABLE LOSS (dB)	PREAMP FACTOR (dB)	ANTENNA HEIGHT (cm)	TABLE ANGLE (Degree)	REMARK
5150	53.23	54.30	74.00	-20.77	34.52	9.92	45.51	115	37	Peak
5150	47.67	48.74	54.00	-6.33	34.52	9.92	45.51	115	37	Average
5310	98.27	99.27	/	/	34.65	9.86	45.51	115	37	Peak
5310	92.73	93.73	/	/	34.65	9.86	45.51	115	37	Average
5350	56.70	57.68	74.00	-17.30	34.68	9.85	45.51	115	37	Peak
5350	50.91	51.89	54.00	-3.09	34.68	9.85	45.51	115	37	Average

ANTENNA POLARITY & TEST DISTANCE: VERTICAL AT 3 M

FREQ. (MHz)	EMISSION LEVEL (dBuV/m)	READ LEVEL (dBuV)	LIMIT (dBuV/m)	MARGIN (dB)	ANTENNA FACTOR (dB /m)	CABLE LOSS (dB)	PREAMP FACTOR (dB)	ANTENNA HEIGHT (cm)	TABLE ANGLE (Degree)	REMARK
5150	53.80	54.79	74.00	-20.20	34.60	9.92	45.51	100	350	Peak
5150	47.59	48.58	54.00	-6.41	34.60	9.92	45.51	100	350	Average
5310	97.35	98.40	/	/	34.60	9.86	45.51	100	350	Peak
5310	92.07	93.12	/	/	34.60	9.86	45.51	100	350	Average
5350	56.49	57.55	74.00	-17.51	34.60	9.85	45.51	100	350	Peak
5350	50.64	51.70	54.00	-3.36	34.60	9.85	45.51	100	350	Average

REMARKS:

- Emission Level = Read Level+ Antenna Factor + Cable Loss- Preamp Factor
Margin value = Emission level – Limit value.
- 5310MHz: Fundamental frequency.



802.11ac (80MHz)

CHANNEL	TX Channel 58	DETECTOR FUNCTION	Peak (PK)
FREQUENCY RANGE	1GHz ~ 40GHz		Average (AV)

ANTENNA POLARITY & TEST DISTANCE: HORIZONTAL AT 3 M										
FREQ. (MHz)	EMISSION LEVEL (dBuV/m)	READ LEVEL (dBuV)	LIMIT (dBuV/m)	MARGIN (dB)	ANTENNA FACTOR (dB /m)	CABLE LOSS (dB)	PREAMP FACTOR (dB)	ANTENNA HEIGHT (cm)	TABLE ANGLE (Degree)	REMARK
5150	54.69	55.76	74	-19.31	34.52	9.92	45.51	100	100	Peak
5150	48.4	49.47	54	-5.6	34.52	9.92	45.51	100	100	Average
5290	93.27	94.28	/	/	34.63	9.87	45.51	100	100	Peak
5290	88.51	89.52	/	/	34.63	9.87	45.51	100	100	Average
5350	55.61	56.59	74	-18.39	34.68	9.85	45.51	100	100	Peak
5350	50.39	51.37	54	-3.61	34.68	9.85	45.51	100	100	Average

ANTENNA POLARITY & TEST DISTANCE: VERTICAL AT 3 M										
FREQ. (MHz)	EMISSION LEVEL (dBuV/m)	READ LEVEL (dBuV)	LIMIT (dBuV/m)	MARGIN (dB)	ANTENNA FACTOR (dB /m)	CABLE LOSS (dB)	PREAMP FACTOR (dB)	ANTENNA HEIGHT (cm)	TABLE ANGLE (Degree)	REMARK
5150	53.3	54.29	74	-20.7	34.6	9.92	45.51	100	0	Peak
5150	48.07	49.06	54	-5.93	34.6	9.92	45.51	100	0	Average
5290	92.82	93.86	/	/	34.6	9.87	45.51	100	0	Peak
5290	87.92	88.96	/	/	34.6	9.87	45.51	100	0	Average
5350	55.26	56.32	74	-18.74	34.6	9.85	45.51	100	0	Peak
5350	49.79	50.85	54	-4.21	34.6	9.85	45.51	100	0	Average

REMARKS:

- Emission Level = Read Level+ Antenna Factor + Cable Loss- Preamp Factor
Margin value = Emission level – Limit value.
- 5290MHz: Fundamental frequency.



802.11ac (80MHz)

Worst case harmonic:

CHANNEL	TX Channel 58	DETECTOR FUNCTION	Peak (PK)
FREQUENCY RANGE	1GHz ~ 40GHz		Average (AV)

ANTENNA POLARITY & TEST DISTANCE: HORIZONTAL AT 3 M

	Freq	Level	Read Level	Limit Line	Over Limit	Factor	Remark	Pol/Phase
	MHz	dBuV/m	dBuV	dBuV/m	dB	dB/m		
1	10580.000	53.27	46.33	74.00	-20.73	6.94	Peak	Horizontal
2	10580.000	44.05	37.11	54.00	-9.95	6.94	Average	Horizontal
3	PK15875.000	55.46	41.40	74.00	-18.54	14.06	Peak	Horizontal
4	PP15875.000	47.72	33.66	54.00	-6.28	14.06	Average	Horizontal

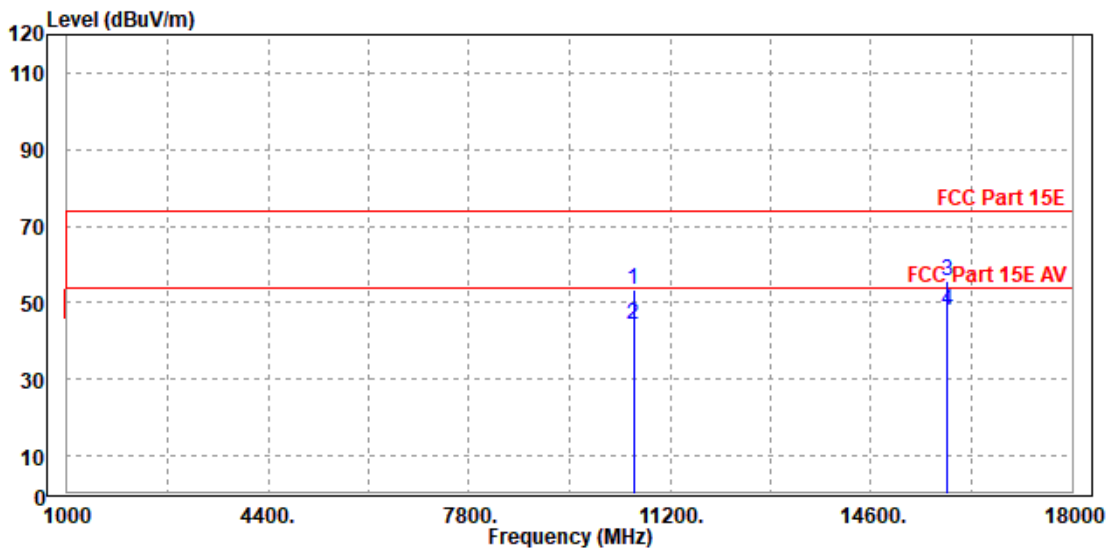



ANTENNA POLARITY & TEST DISTANCE: VERTICAL AT 3 M

	Freq	Level	Read Level	Limit Line	Over Limit	Factor	Remark	Pol/Phase
	MHz	dBuV/m	dBuV	dBuV/m	dB	dB/m		
1	10588.000	53.88	45.72	74.00	-20.12	8.16	Peak	Vertical
2	10588.000	44.83	36.67	54.00	-9.17	8.16	Average	Vertical
3	PK15875.000	54.63	41.99	74.00	-19.37	12.64	Peak	Vertical
4	PP15875.000	46.29	33.65	54.00	-7.71	12.64	Average	Vertical

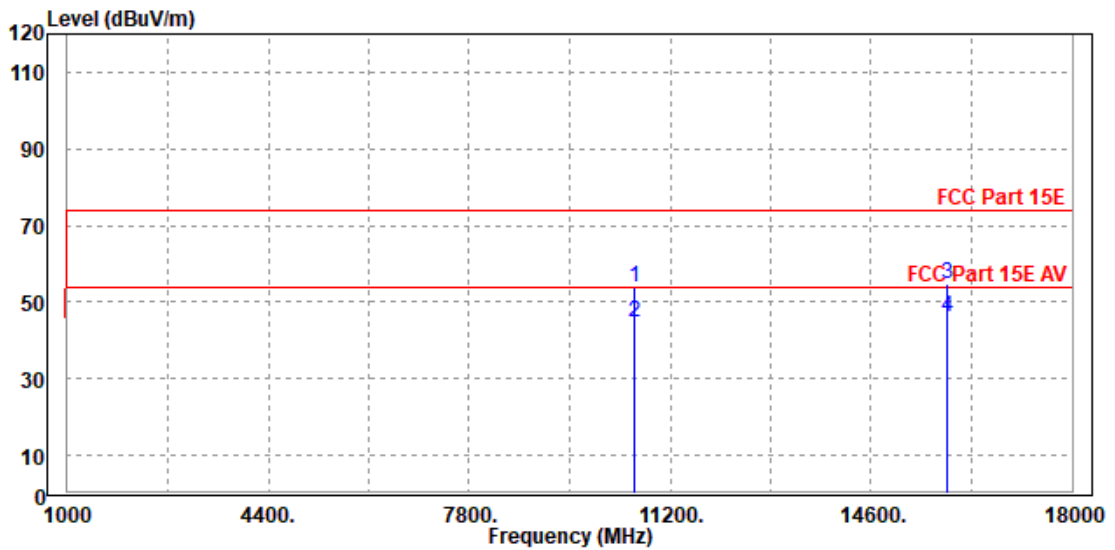

REMARKS:

1. Emission Level = Read Level+ Antenna Factor + Cable Loss- Preamp Factor
Margin value = Emission level – Limit value.
2. 5290MHz: Fundamental frequency.
3. For frequency above 18GHz, the emission was tested 20db below the limit so the data not recorded in the sheet.



Band 3

802.11a

CHANNEL	TX Channel 100	DETECTOR FUNCTION	Peak (PK)
FREQUENCY RANGE	1GHz ~ 40GHz		Average (AV)

ANTENNA POLARITY & TEST DISTANCE: HORIZONTAL AT 3 M										
FREQ. (MHz)	EMISSION LEVEL (dBuV/m)	READ LEVEL (dBuV)	LIMIT (dBuV/m)	MARGIN (dB)	ANTENNA FACTOR (dB /m)	CABLE LOSS (dB)	PREAMP FACTOR (dB)	ANTENNA HEIGHT (cm)	TABLE ANGLE (Degree)	REMARK
5460	53.8	54.73	74	-20.2	34.77	9.81	45.51	100	25	Peak
5460	49.71	50.64	54	-4.29	34.77	9.81	45.51	100	25	Average
5470	56.84	57.76	68.2	-11.36	34.78	9.81	45.51	100	25	Peak
5500	102.65	103.55	/	/	34.8	9.8	45.5	100	25	Peak
5500	97.83	98.73	/	/	34.8	9.8	45.5	100	25	Average

ANTENNA POLARITY & TEST DISTANCE: VERTICAL AT 3 M										
FREQ. (MHz)	EMISSION LEVEL (dBuV/m)	READ LEVEL (dBuV)	LIMIT (dBuV/m)	MARGIN (dB)	ANTENNA FACTOR (dB /m)	CABLE LOSS (dB)	PREAMP FACTOR (dB)	ANTENNA HEIGHT (cm)	TABLE ANGLE (Degree)	REMARK
5460	55.2	56.3	74	-18.8	34.6	9.81	45.51	100	340	Peak
5460	49.13	50.23	54	-4.87	34.6	9.81	45.51	100	340	Average
5470	57.03	58.13	68.2	-11.17	34.6	9.81	45.51	100	340	Peak
5500	103.05	104.15	/	/	34.6	9.8	45.5	100	340	Peak
5500	97.72	98.82	/	/	34.6	9.8	45.5	100	340	Average

REMARKS:

- Emission Level = Read Level+ Antenna Factor + Cable Loss- Preamp Factor
Margin value = Emission level – Limit value.
- 5500MHz: Fundamental frequency.
- #: Out of restricted band.



CHANNEL	TX Channel 116	DETECTOR FUNCTION	Peak (PK)
FREQUENCY RANGE	1GHz ~ 40GHz		Average (AV)

ANTENNA POLARITY & TEST DISTANCE: HORIZONTAL AT 3 M										
FREQ. (MHz)	EMISSION LEVEL (dBuV/m)	READ LEVEL (dBuV)	LIMIT (dBuV/m)	MARGIN (dB)	ANTENNA FACTOR (dB /m)	CABLE LOSS (dB)	PREAMP FACTOR (dB)	ANTENNA HEIGHT (cm)	TABLE ANGLE (Degree)	REMARK
5460	53.77	54.7	74	-20.23	34.77	9.81	45.51	100	25	Peak
5460	49.91	50.84	54	-4.09	34.77	9.81	45.51	100	25	Average
5470	53.24	54.16	68.2	-14.96	34.78	9.81	45.51	100	25	Peak
5580	102.5	103.27	/	/	34.9	9.83	45.5	100	25	Peak
5580	97.89	98.66	/	/	34.9	9.83	45.5	100	25	Average

ANTENNA POLARITY & TEST DISTANCE: VERTICAL AT 3 M										
FREQ. (MHz)	EMISSION LEVEL (dBuV/m)	READ LEVEL (dBuV)	LIMIT (dBuV/m)	MARGIN (dB)	ANTENNA FACTOR (dB /m)	CABLE LOSS (dB)	PREAMP FACTOR (dB)	ANTENNA HEIGHT (cm)	TABLE ANGLE (Degree)	REMARK
5460	53.04	54.14	74	-20.96	34.6	9.81	45.51	100	340	Peak
5460	49.46	50.56	54	-4.54	34.6	9.81	45.51	100	340	Average
5470	53.6	54.7	68.2	-14.6	34.6	9.81	45.51	100	340	Peak
5580	102.03	103	/	/	34.7	9.83	45.5	100	340	Peak
5580	96.68	97.65	/	/	34.7	9.83	45.5	100	340	Average

REMARKS:

- Emission Level = Read Level+ Antenna Factor + Cable Loss- Preamp Factor
Margin value = Emission level – Limit value.
- 5580MHz: Fundamental frequency.
- #: Out of restricted band.



CHANNEL	TX Channel 140	DETECTOR FUNCTION	Peak (PK)
FREQUENCY RANGE	1GHz ~ 40GHz		Average (AV)

ANTENNA POLARITY & TEST DISTANCE: HORIZONTAL AT 3 M

FREQ. (MHz)	EMISSION LEVEL (dBuV/m)	READ LEVEL (dBuV)	LIMIT (dBuV/m)	MARGIN (dB)	ANTENNA FACTOR (dB /m)	CABLE LOSS (dB)	PREAMP FACTOR (dB)	ANTENNA HEIGHT (cm)	TABLE ANGLE (Degree)	REMARK
5700	100.93	101.52	/	/	35.04	9.87	45.5	100	25	Peak
5700	95.62	96.21	/	/	35.04	9.87	45.5	100	25	Average
5725	64.03	64.58	68.2	-4.17	35.07	9.88	45.5	100	25	Peak

ANTENNA POLARITY & TEST DISTANCE: VERTICAL AT 3 M

FREQ. (MHz)	EMISSION LEVEL (dBuV/m)	READ LEVEL (dBuV)	LIMIT (dBuV/m)	MARGIN (dB)	ANTENNA FACTOR (dB /m)	CABLE LOSS (dB)	PREAMP FACTOR (dB)	ANTENNA HEIGHT (cm)	TABLE ANGLE (Degree)	REMARK
5700	102.37	103.16	/	/	34.84	9.87	45.5	100	340	Peak
5700	97.75	98.54	/	/	34.84	9.87	45.5	100	340	Average
5725	65.1	65.85	68.2	-3.1	34.87	9.88	45.5	100	340	Peak

REMARKS:

- Emission Level = Read Level+ Antenna Factor + Cable Loss- Preamp Factor
Margin value = Emission level – Limit value.
- 5700MHz: Fundamental frequency.
- #: Out of restricted band.



802.11n (20MHz)

CHANNEL	TX Channel 100	DETECTOR FUNCTION	Peak (PK)
FREQUENCY RANGE	1GHz ~ 40GHz		Average (AV)

ANTENNA POLARITY & TEST DISTANCE: HORIZONTAL AT 3 M

FREQ. (MHz)	EMISSION LEVEL (dBuV/m)	READ LEVEL (dBuV)	LIMIT (dBuV/m)	MARGIN (dB)	ANTENNA FACTOR (dB /m)	CABLE LOSS (dB)	PREAMP FACTOR (dB)	ANTENNA HEIGHT (cm)	TABLE ANGLE (Degree)	REMARK
5460	53.58	54.51	74	-20.42	34.77	9.81	45.51	100	25	Peak
5460	49.39	50.32	54	-4.61	34.77	9.81	45.51	100	25	Average
5470	56.74	57.66	68.2	-11.46	34.78	9.81	45.51	100	25	Peak
5500	102.21	103.11	/	/	34.8	9.8	45.5	100	25	Peak
5500	97.42	98.32	/	/	34.8	9.8	45.5	100	25	Average

ANTENNA POLARITY & TEST DISTANCE: VERTICAL AT 3 M

FREQ. (MHz)	EMISSION LEVEL (dBuV/m)	READ LEVEL (dBuV)	LIMIT (dBuV/m)	MARGIN (dB)	ANTENNA FACTOR (dB /m)	CABLE LOSS (dB)	PREAMP FACTOR (dB)	ANTENNA HEIGHT (cm)	TABLE ANGLE (Degree)	REMARK
5460	53.5	54.6	74	-20.5	34.6	9.81	45.51	100	340	Peak
5460	49.77	50.87	54	-4.23	34.6	9.81	45.51	100	340	Average
5470	58.13	59.23	68.2	-10.07	34.6	9.81	45.51	100	340	Peak
5500	102.02	103.12	/	/	34.6	9.8	45.5	100	340	Peak
5500	97.11	98.21	/	/	34.6	9.8	45.5	100	340	Average

REMARKS:

- Emission Level = Read Level+ Antenna Factor + Cable Loss- Preamp Factor
Margin value = Emission level – Limit value.
- 5500MHz: Fundamental frequency.
- #: Out of restricted band.



CHANNEL	TX Channel 116	DETECTOR FUNCTION	Peak (PK)
FREQUENCY RANGE	1GHz ~ 40GHz		Average (AV)

ANTENNA POLARITY & TEST DISTANCE: HORIZONTAL AT 3 M

FREQ. (MHz)	EMISSION LEVEL (dBuV/m)	READ LEVEL (dBuV)	LIMIT (dBuV/m)	MARGIN (dB)	ANTENNA FACTOR (dB /m)	CABLE LOSS (dB)	PREAMP FACTOR (dB)	ANTENNA HEIGHT (cm)	TABLE ANGLE (Degree)	REMARK
5460	54.08	55.01	74	-19.92	34.77	9.81	45.51	100	25	Peak
5460	48.6	49.53	54	-5.4	34.77	9.81	45.51	100	25	Average
5470	54.23	55.15	68.2	-13.97	34.78	9.81	45.51	100	25	Peak
5580	102.38	103.15	/	/	34.9	9.83	45.5	100	25	Peak
5580	97.29	98.06	/	/	34.9	9.83	45.5	100	25	Average

ANTENNA POLARITY & TEST DISTANCE: VERTICAL AT 3 M

FREQ. (MHz)	EMISSION LEVEL (dBuV/m)	READ LEVEL (dBuV)	LIMIT (dBuV/m)	MARGIN (dB)	ANTENNA FACTOR (dB /m)	CABLE LOSS (dB)	PREAMP FACTOR (dB)	ANTENNA HEIGHT (cm)	TABLE ANGLE (Degree)	REMARK
5460	53.8	54.9	74	-20.2	34.6	9.81	45.51	100	340	Peak
5460	49	50.1	54	-5	34.6	9.81	45.51	100	340	Average
5470	53.31	54.41	68.2	-14.89	34.6	9.81	45.51	100	340	Peak
5580	101.6	102.57	/	/	34.7	9.83	45.5	100	340	Peak
5580	96.37	97.34	/	/	34.7	9.83	45.5	100	340	Average

REMARKS:

- Emission Level = Read Level+ Antenna Factor + Cable Loss- Preamp Factor
Margin value = Emission level – Limit value.
- 5580MHz: Fundamental frequency.
- #: Out of restricted band.



CHANNEL	TX Channel 140	DETECTOR FUNCTION	Peak (PK)
FREQUENCY RANGE	1GHz ~ 40GHz		Average (AV)

ANTENNA POLARITY & TEST DISTANCE: HORIZONTAL AT 3 M

FREQ. (MHz)	EMISSION LEVEL (dBuV/m)	READ LEVEL (dBuV)	LIMIT (dBuV/m)	MARGIN (dB)	ANTENNA FACTOR (dB /m)	CABLE LOSS (dB)	PREAMP FACTOR (dB)	ANTENNA HEIGHT (cm)	TABLE ANGLE (Degree)	REMARK
5700	101.58	102.17	/	/	35.04	9.87	45.5	100	25	Peak
5700	96.29	96.88	/	/	35.04	9.87	45.5	100	25	Average
5725	63.1	63.65	68.2	-5.1	35.07	9.88	45.5	100	25	Peak

ANTENNA POLARITY & TEST DISTANCE: VERTICAL AT 3 M

FREQ. (MHz)	EMISSION LEVEL (dBuV/m)	READ LEVEL (dBuV)	LIMIT (dBuV/m)	MARGIN (dB)	ANTENNA FACTOR (dB /m)	CABLE LOSS (dB)	PREAMP FACTOR (dB)	ANTENNA HEIGHT (cm)	TABLE ANGLE (Degree)	REMARK
5700	101.76	102.55	/	/	34.84	9.87	45.5	100	340	Peak
5700	97.27	98.06	/	/	34.84	9.87	45.5	100	340	Average
5725	64.78	65.53	68.2	-3.42	34.87	9.88	45.5	100	340	Peak

REMARKS:

- Emission Level = Read Level+ Antenna Factor + Cable Loss- Preamp Factor
Margin value = Emission level – Limit value.
- 5700MHz: Fundamental frequency.
- #: Out of restricted band.



802.11n (40MHz)

CHANNEL	TX Channel 102	DETECTOR FUNCTION	Peak (PK)
FREQUENCY RANGE	1GHz ~ 40GHz		Average (AV)

ANTENNA POLARITY & TEST DISTANCE: HORIZONTAL AT 3 M

FREQ. (MHz)	EMISSION LEVEL (dBuV/m)	READ LEVEL (dBuV)	LIMIT (dBuV/m)	MARGIN (dB)	ANTENNA FACTOR (dB /m)	CABLE LOSS (dB)	PREAMP FACTOR (dB)	ANTENNA HEIGHT (cm)	TABLE ANGLE (Degree)	REMARK
5460	54.97	55.9	74	-19.03	34.77	9.81	45.51	100	25	Peak
5460	49.83	50.76	54	-4.17	34.77	9.81	45.51	100	25	Average
5470	58.57	59.49	68.2	-9.63	34.78	9.81	45.51	100	25	Peak
5510	97.78	98.67	/	/	34.81	9.8	45.5	100	25	Peak
5510	91.93	92.82	/	/	34.81	9.8	45.5	100	25	Average

ANTENNA POLARITY & TEST DISTANCE: VERTICAL AT 3 M

FREQ. (MHz)	EMISSION LEVEL (dBuV/m)	READ LEVEL (dBuV)	LIMIT (dBuV/m)	MARGIN (dB)	ANTENNA FACTOR (dB /m)	CABLE LOSS (dB)	PREAMP FACTOR (dB)	ANTENNA HEIGHT (cm)	TABLE ANGLE (Degree)	REMARK
5460	54.85	55.95	74	-19.15	34.6	9.81	45.51	100	340	Peak
5460	49.7	50.8	54	-4.3	34.6	9.81	45.51	100	340	Average
5470	56.4	57.5	68.2	-11.8	34.6	9.81	45.51	100	340	Peak
5510	97.41	98.5	/	/	34.61	9.8	45.5	100	340	Peak
5510	92.45	93.54	/	/	34.61	9.8	45.5	100	340	Average

REMARKS:

- Emission Level = Read Level+ Antenna Factor + Cable Loss- Preamp Factor
Margin value = Emission level – Limit value.
- 5510MHz: Fundamental frequency.
- #: Out of restricted band.



CHANNEL	TX Channel 110	DETECTOR FUNCTION	Peak (PK)
FREQUENCY RANGE	1GHz ~ 40GHz		Average (AV)

ANTENNA POLARITY & TEST DISTANCE: HORIZONTAL AT 3 M										
FREQ. (MHz)	EMISSION LEVEL (dBuV/m)	READ LEVEL (dBuV)	LIMIT (dBuV/m)	MARGIN (dB)	ANTENNA FACTOR (dB /m)	CABLE LOSS (dB)	PREAMP FACTOR (dB)	ANTENNA HEIGHT (cm)	TABLE ANGLE (Degree)	REMARK
5460	53.62	54.55	74	-20.38	34.77	9.81	45.51	100	25	Peak
5460	47.95	48.88	54	-6.05	34.77	9.81	45.51	100	25	Average
5470	53.79	54.71	68.2	-14.41	34.78	9.81	45.51	100	25	Peak
5550	97.3	98.12	/	/	34.86	9.82	45.5	100	25	Peak
5550	92.07	92.89	/	/	34.86	9.82	45.5	100	25	Average

ANTENNA POLARITY & TEST DISTANCE: VERTICAL AT 3 M										
FREQ. (MHz)	EMISSION LEVEL (dBuV/m)	READ LEVEL (dBuV)	LIMIT (dBuV/m)	MARGIN (dB)	ANTENNA FACTOR (dB /m)	CABLE LOSS (dB)	PREAMP FACTOR (dB)	ANTENNA HEIGHT (cm)	TABLE ANGLE (Degree)	REMARK
5460	53.45	54.55	74	-20.55	34.6	9.81	45.51	100	340	Peak
5460	47.68	48.78	54	-6.32	34.6	9.81	45.51	100	340	Average
5470	53.62	54.72	68.2	-14.58	34.6	9.81	45.51	100	340	Peak
5550	96.98	98	/	/	34.66	9.82	45.5	100	340	Peak
5550	91.41	92.43	/	/	34.66	9.82	45.5	100	340	Average

REMARKS:

- Emission Level = Read Level+ Antenna Factor + Cable Loss- Preamp Factor
Margin value = Emission level – Limit value.
- 5500MHz: Fundamental frequency.
- #: Out of restricted band.



CHANNEL	TX Channel 134	DETECTOR FUNCTION	Peak (PK)
FREQUENCY RANGE	1GHz ~ 40GHz		Average (AV)

ANTENNA POLARITY & TEST DISTANCE: HORIZONTAL AT 3 M

FREQ. (MHz)	EMISSION LEVEL (dBuV/m)	READ LEVEL (dBuV)	LIMIT (dBuV/m)	MARGIN (dB)	ANTENNA FACTOR (dB /m)	CABLE LOSS (dB)	PREAMP FACTOR (dB)	ANTENNA HEIGHT (cm)	TABLE ANGLE (Degree)	REMARK
5670	96.56	97.2	/	/	35	9.86	45.5	100	25	Peak
5670	90.95	91.59	/	/	35	9.86	45.5	100	25	Average
5725	54.48	55.03	68.2	-13.72	35.07	9.88	45.5	100	25	Peak

ANTENNA POLARITY & test distance: Vertical at 3 m

FREQ. (MHz)	EMISSION LEVEL (dBuV/m)	READ LEVEL (dBuV)	LIMIT (dBuV/m)	MARGIN (dB)	ANTENNA FACTOR (dB /m)	CABLE LOSS (dB)	PREAMP FACTOR (dB)	ANTENNA HEIGHT (cm)	TABLE ANGLE (Degree)	REMARK
5670	97.32	98.16	/	/	34.8	9.86	45.5	100	340	Peak
5670	91.36	92.2	/	/	34.8	9.86	45.5	100	340	Average
5725	53.5	54.25	68.2	-14.7	34.87	9.88	45.5	100	340	Peak

REMARKS:

- Emission Level = Read Level+ Antenna Factor + Cable Loss- Preamp Factor
Margin value = Emission level – Limit value.
- 5670MHz: Fundamental frequency.
- #: Out of restricted band.



802.11ac (20MHz)

CHANNEL	TX Channel 100	DETECTOR FUNCTION	Peak (PK)
FREQUENCY RANGE	1GHz ~ 40GHz		Average (AV)

ANTENNA POLARITY & TEST DISTANCE: HORIZONTAL AT 3 M										
FREQ. (MHz)	EMISSION LEVEL (dBuV/m)	READ LEVEL (dBuV)	LIMIT (dBuV/m)	MARGIN (dB)	ANTENNA FACTOR (dB /m)	CABLE LOSS (dB)	PREAMP FACTOR (dB)	ANTENNA HEIGHT (cm)	TABLE ANGLE (Degree)	REMARK
5460	54.05	54.98	74	-19.95	34.77	9.81	45.51	100	25	Peak
5460	50.14	51.07	54	-3.86	34.77	9.81	45.51	100	25	Average
5470	56.82	57.74	68.2	-11.38	34.78	9.81	45.51	100	25	Peak
5500	102.11	103.01	/	/	34.8	9.8	45.5	100	25	Peak
5500	97.83	98.73	/	/	34.8	9.8	45.5	100	25	Average

ANTENNA POLARITY & TEST DISTANCE: VERTICAL AT 3 M										
FREQ. (MHz)	EMISSION LEVEL (dBuV/m)	READ LEVEL (dBuV)	LIMIT (dBuV/m)	MARGIN (dB)	ANTENNA FACTOR (dB /m)	CABLE LOSS (dB)	PREAMP FACTOR (dB)	ANTENNA HEIGHT (cm)	TABLE ANGLE (Degree)	REMARK
5460	54.58	55.68	74	-19.42	34.6	9.81	45.51	100	340	Peak
5460	48.59	49.69	54	-5.41	34.6	9.81	45.51	100	340	Average
5470	56.32	57.42	68.2	-11.88	34.6	9.81	45.51	100	340	Peak
5500	102.07	103.17	/	/	34.6	9.8	45.5	100	340	Peak
5500	97.39	98.49	/	/	34.6	9.8	45.5	100	340	Average

REMARKS:

- Emission Level = Read Level+ Antenna Factor + Cable Loss- Preamp Factor
Margin value = Emission level – Limit value.
- 5500MHz: Fundamental frequency.
- #: Out of restricted band.



CHANNEL	TX Channel 116	DETECTOR FUNCTION	Peak (PK)
FREQUENCY RANGE	1GHz ~ 40GHz		Average (AV)

ANTENNA POLARITY & TEST DISTANCE: HORIZONTAL AT 3 M

FREQ. (MHz)	EMISSION LEVEL (dBuV/m)	READ LEVEL (dBuV)	LIMIT (dBuV/m)	MARGIN (dB)	ANTENNA FACTOR (dB /m)	CABLE LOSS (dB)	PREAMP FACTOR (dB)	ANTENNA HEIGHT (cm)	TABLE ANGLE (Degree)	REMARK
5460	55	55.93	74	-19	34.77	9.81	45.51	100	25	Peak
5460	49.23	50.16	54	-4.77	34.77	9.81	45.51	100	25	Average
5470	54.88	55.8	68.2	-13.32	34.78	9.81	45.51	100	25	Peak
5580	102.37	103.14	/	/	34.9	9.83	45.5	100	25	Peak
5580	97.94	98.71	/	/	34.9	9.83	45.5	100	25	Average

ANTENNA POLARITY & TEST DISTANCE: VERTICAL AT 3 M

FREQ. (MHz)	EMISSION LEVEL (dBuV/m)	READ LEVEL (dBuV)	LIMIT (dBuV/m)	MARGIN (dB)	ANTENNA FACTOR (dB /m)	CABLE LOSS (dB)	PREAMP FACTOR (dB)	ANTENNA HEIGHT (cm)	TABLE ANGLE (Degree)	REMARK
5460	53.89	54.99	74	-20.11	34.6	9.81	45.51	100	340	Peak
5460	48.99	50.09	54	-5.01	34.6	9.81	45.51	100	340	Average
5470	53	54.1	68.2	-15.2	34.6	9.81	45.51	100	340	Peak
5580	101.93	102.9	/	/	34.7	9.83	45.5	100	340	Peak
5580	96.76	97.73	/	/	34.7	9.83	45.5	100	340	Average

REMARKS:

- Emission Level = Read Level+ Antenna Factor + Cable Loss- Preamp Factor
Margin value = Emission level – Limit value.
- 5580MHz: Fundamental frequency.
- #: Out of restricted band.



CHANNEL	TX Channel 140	DETECTOR FUNCTION	Peak (PK)
FREQUENCY RANGE	1GHz ~ 40GHz		Average (AV)

ANTENNA POLARITY & TEST DISTANCE: HORIZONTAL AT 3 M

FREQ. (MHz)	EMISSION LEVEL (dBuV/m)	READ LEVEL (dBuV)	LIMIT (dBuV/m)	MARGIN (dB)	ANTENNA FACTOR (dB /m)	CABLE LOSS (dB)	PREAMP FACTOR (dB)	ANTENNA HEIGHT (cm)	TABLE ANGLE (Degree)	REMARK
5700	100.51	101.1	/	/	35.04	9.87	45.5	100	25	Peak
5700	96	96.59	/	/	35.04	9.87	45.5	100	25	Average
5725	64.6	65.15	68.2	-3.6	35.07	9.88	45.5	100	25	Peak

ANTENNA POLARITY & TEST DISTANCE: VERTICAL AT 3 M

FREQ. (MHz)	EMISSION LEVEL (dBuV/m)	READ LEVEL (dBuV)	LIMIT (dBuV/m)	MARGIN (dB)	ANTENNA FACTOR (dB /m)	CABLE LOSS (dB)	PREAMP FACTOR (dB)	ANTENNA HEIGHT (cm)	TABLE ANGLE (Degree)	REMARK
5700	102.03	102.82	/	/	34.84	9.87	45.5	100	340	Peak
5700	97.33	98.12	/	/	34.84	9.87	45.5	100	340	Average
5725	64.82	65.57	68.2	-3.38	34.87	9.88	45.5	100	340	Peak

REMARKS:

- Emission Level = Read Level+ Antenna Factor + Cable Loss- Preamp Factor
Margin value = Emission level – Limit value.
- 5700MHz: Fundamental frequency.
- #: Out of restricted band.



802.11ac (40MHz)

CHANNEL	TX Channel 102	DETECTOR FUNCTION	Peak (PK)
FREQUENCY RANGE	1GHz ~ 40GHz		Average (AV)

ANTENNA POLARITY & TEST DISTANCE: HORIZONTAL AT 3 M

FREQ. (MHz)	EMISSION LEVEL (dBuV/m)	READ LEVEL (dBuV)	LIMIT (dBuV/m)	MARGIN (dB)	ANTENNA FACTOR (dB /m)	CABLE LOSS (dB)	PREAMP FACTOR (dB)	ANTENNA HEIGHT (cm)	TABLE ANGLE (Degree)	REMARK
5460	54.85	55.78	74	-19.15	34.77	9.81	45.51	100	25	Peak
5460	50.08	51.01	54	-3.92	34.77	9.81	45.51	100	25	Average
5470	59.65	60.57	68.2	-8.55	34.78	9.81	45.51	100	25	Peak
5510	96.5	97.39	/	/	34.81	9.8	45.5	100	25	Peak
5510	92.28	93.17	/	/	34.81	9.8	45.5	100	25	Average

ANTENNA POLARITY & TEST DISTANCE: VERTICAL AT 3 M

FREQ. (MHz)	EMISSION LEVEL (dBuV/m)	READ LEVEL (dBuV)	LIMIT (dBuV/m)	MARGIN (dB)	ANTENNA FACTOR (dB /m)	CABLE LOSS (dB)	PREAMP FACTOR (dB)	ANTENNA HEIGHT (cm)	TABLE ANGLE (Degree)	REMARK
5460	57.13	58.23	74	-16.87	34.6	9.81	45.51	100	340	Peak
5460	50.6	51.7	54	-3.4	34.6	9.81	45.51	100	340	Average
5470	58.64	59.74	68.2	-9.56	34.6	9.81	45.51	100	340	Peak
5510	97.29	98.38	/	/	34.61	9.8	45.5	100	340	Peak
5510	92.87	93.96	/	/	34.61	9.8	45.5	100	340	Average

REMARKS:

- Emission Level = Read Level+ Antenna Factor + Cable Loss- Preamp Factor
Margin value = Emission level – Limit value.
- 5510MHz: Fundamental frequency.
- #: Out of restricted band.



CHANNEL	TX Channel 110	DETECTOR FUNCTION	Peak (PK)
FREQUENCY RANGE	1GHz ~ 40GHz		Average (AV)

ANTENNA POLARITY & TEST DISTANCE: HORIZONTAL AT 3 M

FREQ. (MHz)	EMISSION LEVEL (dBuV/m)	READ LEVEL (dBuV)	LIMIT (dBuV/m)	MARGIN (dB)	ANTENNA FACTOR (dB /m)	CABLE LOSS (dB)	PREAMP FACTOR (dB)	ANTENNA HEIGHT (cm)	TABLE ANGLE (Degree)	REMARK
5460	52.81	53.74	74	-21.19	34.77	9.81	45.51	100	25	Peak
5460	47.41	48.34	54	-6.59	34.77	9.81	45.51	100	25	Average
5470	52.95	53.87	68.2	-15.25	34.78	9.81	45.51	100	25	Peak
5550	96.8	97.62	/	/	34.86	9.82	45.5	100	25	Peak
5550	92.6	93.42	/	/	34.86	9.82	45.5	100	25	Average

ANTENNA POLARITY & TEST DISTANCE: VERTICAL AT 3 M

FREQ. (MHz)	EMISSION LEVEL (dBuV/m)	READ LEVEL (dBuV)	LIMIT (dBuV/m)	MARGIN (dB)	ANTENNA FACTOR (dB /m)	CABLE LOSS (dB)	PREAMP FACTOR (dB)	ANTENNA HEIGHT (cm)	TABLE ANGLE (Degree)	REMARK
5460	53.94	55.04	74	-20.06	34.6	9.81	45.51	100	340	Peak
5460	48.42	49.52	54	-5.58	34.6	9.81	45.51	100	340	Average
5470	53.78	54.88	68.2	-14.42	34.6	9.81	45.51	100	340	Peak
5550	96.72	97.74	/	/	34.66	9.82	45.5	100	340	Peak
5550	91.97	92.99	/	/	34.66	9.82	45.5	100	340	Average

REMARKS:

- Emission Level = Read Level+ Antenna Factor + Cable Loss- Preamp Factor
Margin value = Emission level – Limit value.
- 5500MHz: Fundamental frequency.
- #: Out of restricted band.



CHANNEL	TX Channel 134	DETECTOR FUNCTION	Peak (PK)
FREQUENCY RANGE	1GHz ~ 40GHz		Average (AV)

ANTENNA POLARITY & TEST DISTANCE: HORIZONTAL AT 3 M

FREQ. (MHz)	EMISSION LEVEL (dBuV/m)	READ LEVEL (dBuV)	LIMIT (dBuV/m)	MARGIN (dB)	ANTENNA FACTOR (dB /m)	CABLE LOSS (dB)	PREAMP FACTOR (dB)	ANTENNA HEIGHT (cm)	TABLE ANGLE (Degree)	REMARK
5670	96.53	97.17	/	/	35	9.86	45.5	100	25	Peak
5670	91.77	92.41	/	/	35	9.86	45.5	100	25	Average
5725	55.33	55.88	68.2	-12.87	35.07	9.88	45.5	100	25	Peak

ANTENNA POLARITY & test distance: Vertical at 3 m

FREQ. (MHz)	EMISSION LEVEL (dBuV/m)	READ LEVEL (dBuV)	LIMIT (dBuV/m)	MARGIN (dB)	ANTENNA FACTOR (dB /m)	CABLE LOSS (dB)	PREAMP FACTOR (dB)	ANTENNA HEIGHT (cm)	TABLE ANGLE (Degree)	REMARK
5670	97.03	97.87	/	/	34.8	9.86	45.5	100	340	Peak
5670	91.64	92.48	/	/	34.8	9.86	45.5	100	340	Average
5725	55.34	56.09	68.2	-12.86	34.87	9.88	45.5	100	340	Peak

REMARKS:

- Emission Level = Read Level+ Antenna Factor + Cable Loss- Preamp Factor
Margin value = Emission level – Limit value.
- 5670MHz: Fundamental frequency.
- #: Out of restricted band.



802.11ac (80MHz)

CHANNEL	TX Channel 106	DETECTOR FUNCTION	Peak (PK)
FREQUENCY RANGE	1GHz ~ 40GHz		Average (AV)

ANTENNA POLARITY & TEST DISTANCE: HORIZONTAL AT 3 M										
FREQ. (MHz)	EMISSION LEVEL (dBuV/m)	READ LEVEL (dBuV)	LIMIT (dBuV/m)	MARGIN (dB)	ANTENNA FACTOR (dB /m)	CABLE LOSS (dB)	PREAMP FACTOR (dB)	ANTENNA HEIGHT (cm)	TABLE ANGLE (Degree)	REMARK
5460	54.73	55.66	74	-19.27	34.77	9.81	45.51	100	20	Peak
5460	48.99	49.92	54	-5.01	34.77	9.81	45.51	100	20	Average
5470	55.3	56.22	68.2	-12.9	34.78	9.81	45.51	100	20	Peak
5530	88.52	89.37	/	/	34.84	9.81	45.5	100	20	Peak
5530	84.69	85.54	/	/	34.84	9.81	45.5	100	20	Average

ANTENNA POLARITY & TEST DISTANCE: VERTICAL AT 3 M										
FREQ. (MHz)	EMISSION LEVEL (dBuV/m)	READ LEVEL (dBuV)	LIMIT (dBuV/m)	MARGIN (dB)	ANTENNA FACTOR (dB /m)	CABLE LOSS (dB)	PREAMP FACTOR (dB)	ANTENNA HEIGHT (cm)	TABLE ANGLE (Degree)	REMARK
5460	56.09	57.19	74	-17.91	34.6	9.81	45.51	100	305	Peak
5460	50.23	51.33	54	-3.77	34.6	9.81	45.51	100	305	Average
5470	54.43	55.53	68.2	-13.77	34.6	9.81	45.51	100	305	Peak
5530	90.01	91.06	/	/	34.64	9.81	45.5	100	305	Peak
5530	85.88	86.93	/	/	34.64	9.81	45.5	100	305	Average

REMARKS:

- Emission Level = Read Level+ Antenna Factor + Cable Loss- Preamp Factor
Margin value = Emission level – Limit value.
- 5530MHz: Fundamental frequency.
- #: Out of restricted band.



CHANNEL	TX Channel 122	DETECTOR FUNCTION	Peak (PK)
FREQUENCY RANGE	1GHz ~ 40GHz		Average (AV)

ANTENNA POLARITY & TEST DISTANCE: HORIZONTAL AT 3 M

FREQ. (MHz)	EMISSION LEVEL (dBuV/m)	READ LEVEL (dBuV)	LIMIT (dBuV/m)	MARGIN (dB)	ANTENNA FACTOR (dB /m)	CABLE LOSS (dB)	PREAMP FACTOR (dB)	ANTENNA HEIGHT (cm)	TABLE ANGLE (Degree)	REMARK
5460	52.13	53.06	74	-21.87	34.77	9.81	45.51	100	25	Peak
5460	47.26	48.19	54	-6.74	34.77	9.81	45.51	100	25	Average
5470	53.23	54.15	68.2	-14.97	34.78	9.81	45.51	100	25	Peak
5610	94.4	95.13	/	/	34.93	9.84	45.5	100	25	Peak
5610	89.05	89.78	/	/	34.93	9.84	45.5	100	25	Average

ANTENNA POLARITY & TEST DISTANCE: VERTICAL AT 3 M

FREQ. (MHz)	EMISSION LEVEL (dBuV/m)	READ LEVEL (dBuV)	LIMIT (dBuV/m)	MARGIN (dB)	ANTENNA FACTOR (dB /m)	CABLE LOSS (dB)	PREAMP FACTOR (dB)	ANTENNA HEIGHT (cm)	TABLE ANGLE (Degree)	REMARK
5460	52.61	53.71	74	-21.39	34.6	9.81	45.51	100	340	Peak
5460	47.03	48.13	54	-6.97	34.6	9.81	45.51	100	340	Average
5470	52.28	53.38	68.2	-15.92	34.6	9.81	45.51	100	340	Peak
5610	93.51	94.44	/	/	34.73	9.84	45.5	100	340	Peak
5610	87.69	88.62	/	/	34.73	9.84	45.5	100	340	Average

REMARKS:

- Emission Level = Read Level+ Antenna Factor + Cable Loss- Preamp Factor
Margin value = Emission level – Limit value.
- 5610MHz: Fundamental frequency.
- #: Out of restricted band.



802.11a

Worst case harmonic:

CHANNEL	TX Channel 140	DETECTOR FUNCTION	Peak (PK)
FREQUENCY RANGE	1GHz ~ 40GHz		Average (AV)

ANTENNA POLARITY & TEST DISTANCE: HORIZONTAL AT 3 M

	Freq	Level	Read Level	Limit Line	Over Limit	Factor	Remark	Pol/Phase
	MHz	dBuV/m	dBuV	dBuV/m	dB	dB/m		
1	11404.000	54.07	45.43	74.00	-19.93	8.64	Peak	Horizontal
2	11404.000	44.76	36.12	54.00	-9.24	8.64	Average	Horizontal
3	PK17100.000	60.32	42.20	74.00	-13.68	18.12	Peak	Horizontal
4	PP17100.000	50.74	32.62	54.00	-3.26	18.12	Average	Horizontal

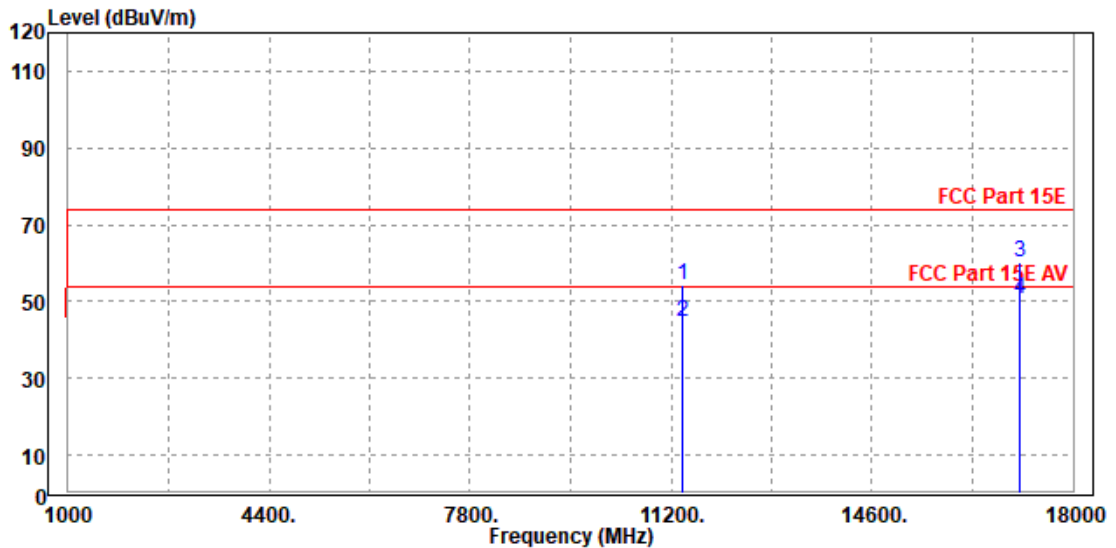



ANTENNA POLARITY & TEST DISTANCE: VERTICAL AT 3 M

	Freq	Level	Read Level	Limit Line	Over Limit	Factor	Remark	Pol/Phase
	MHz	dBuV/m	dBuV	dBuV/m	dB	dB/m		
1	11400.000	53.56	44.38	74.00	-20.44	9.18	Peak	Vertical
2	11400.000	44.50	35.32	54.00	-9.50	9.18	Average	Vertical
3	PK17099.000	59.32	42.84	74.00	-14.68	16.48	Peak	Vertical
4	PP17099.000	48.57	32.09	54.00	-5.43	16.48	Average	Vertical

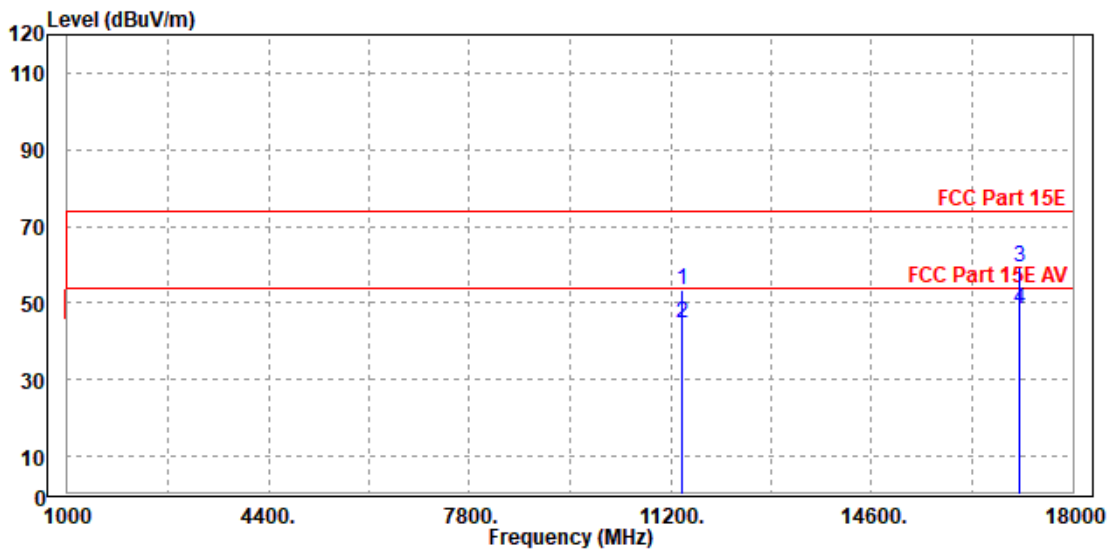

REMARKS:

1. Emission Level = Read Level+ Antenna Factor + Cable Loss- Preamp Factor
Margin value = Emission level – Limit value.
2. 5700MHz: Fundamental frequency.
3. For frequency above 18GHz, the emission was tested 20db below the limit so the data not recorded in the sheet.



Band 4:

802.11a

CHANNEL	TX Channel 149	DETECTOR FUNCTION	Peak (PK)
FREQUENCY RANGE	1GHz ~ 40GHz		Average (AV)

ANTENNA POLARITY & TEST DISTANCE: HORIZONTAL AT 3 M										
FREQ. (MHz)	EMISSION LEVEL (dBuV/m)	READ LEVEL (dBuV)	LIMIT (dBuV/m)	MARGIN (dB)	ANTENNA FACTOR (dB /m)	CABLE LOSS (dB)	PREAMP FACTOR (dB)	ANTENNA HEIGHT (cm)	TABLE ANGLE (Degree)	REMARK
5745	103.82	104.35	/	/	35.09	9.88	45.5	100	25	Peak
5745	96.41	96.94	/	/	35.09	9.88	45.5	100	25	Average
ANTENNA POLARITY & TEST DISTANCE: VERTICAL AT 3 M										
FREQ. (MHz)	EMISSION LEVEL (dBuV/m)	READ LEVEL (dBuV)	LIMIT (dBuV/m)	MARGIN (dB)	ANTENNA FACTOR (dB /m)	CABLE LOSS (dB)	PREAMP FACTOR (dB)	ANTENNA HEIGHT (cm)	TABLE ANGLE (Degree)	REMARK
5745	104.63	105.36	/	/	34.89	9.88	45.5	100	340	Peak
5745	98.21	98.94	/	/	34.89	9.88	45.5	100	340	Average

REMARKS:

- Emission Level = Read Level+ Antenna Factor + Cable Loss- Preamp Factor
Margin value = Emission level – Limit value.
- 5745MHz: Fundamental frequency.



Oobe Data

802.11a

ANTENNA POLARITY & TEST DISTANCE: HORIZONTAL AT 3 M											
FREQ. (MHz)	EMISSION LEVEL (dBuV/m)	READ LEVEL (dBuV)	LIMIT (dBuV/m)	MARGIN (dB)	ANTENNA FACTOR (dB /m)	CABLE LOSS (dB)	PREAMP FACTOR (dB)	ANTENNA HEIGHT (cm)	TABLE ANGLE (Degree)	REMARK	
5578.5	58.91	59.69	68.2	-9.29	34.89	9.83	45.5	100	360	Peak	
5975.6	57.85	58.02	68.2	-10.35	35.37	9.96	45.5	100	360	Peak	

ANTENNA POLARITY & TEST DISTANCE: VERTICAL AT 3 M											
FREQ. (MHz)	EMISSION LEVEL (dBuV/m)	READ LEVEL (dBuV)	LIMIT (dBuV/m)	MARGIN (dB)	ANTENNA FACTOR (dB /m)	CABLE LOSS (dB)	PREAMP FACTOR (dB)	ANTENNA HEIGHT (cm)	TABLE ANGLE (Degree)	REMARK	
5576.6	57.56	58.54	68.2	-10.64	34.69	9.83	45.5	100	0	Peak	
5991.75	58.18	58.52	68.2	-10.02	35.19	9.97	45.5	100	0	Peak	

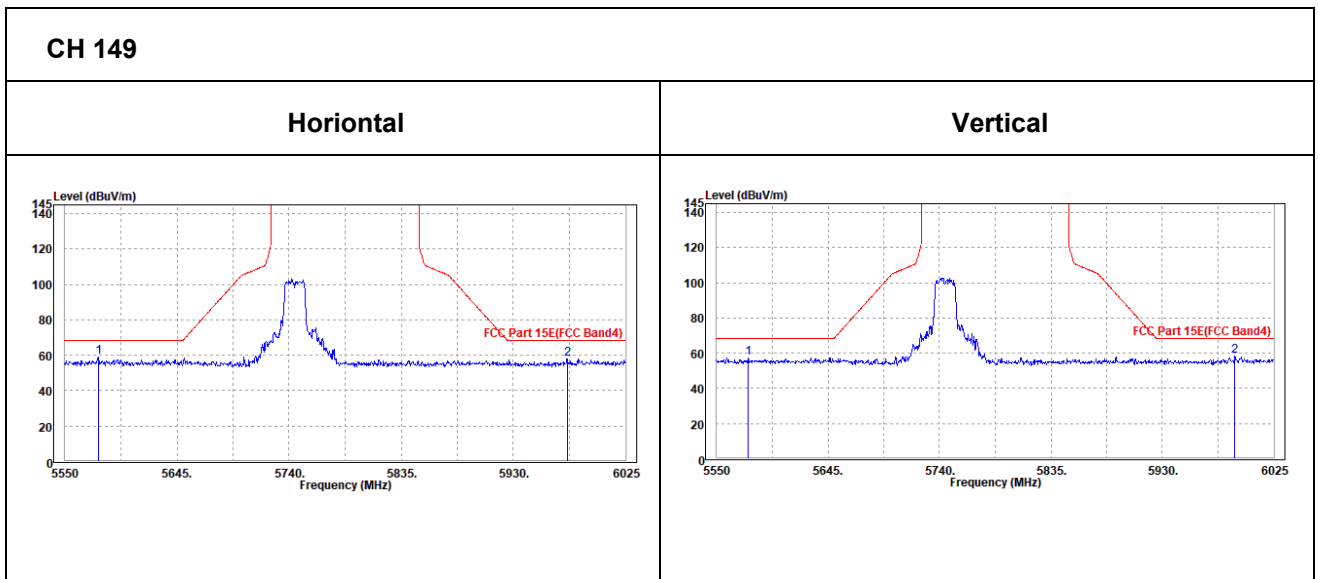



CHANNEL	TX Channel 157	DETECTOR FUNCTION	Peak (PK)
FREQUENCY RANGE	1GHz ~ 40GHz		Average (AV)

ANTENNA POLARITY & TEST DISTANCE: HORIZONTAL AT 3 M

FREQ. (MHz)	EMISSION LEVEL (dBuV/m)	READ LEVEL (dBuV)	LIMIT (dBuV/m)	MARGIN (dB)	ANTENNA FACTOR (dB /m)	CABLE LOSS (dB)	PREAMP FACTOR (dB)	ANTENNA HEIGHT (cm)	TABLE ANGLE (Degree)	REMARK
5785	102.2	102.66	/	/	35.14	9.9	45.5	100	25	Peak
5785	95.89	96.35	/	/	35.14	9.9	45.5	100	25	Average

ANTENNA POLARITY & TEST DISTANCE: VERTICAL AT 3 M

FREQ. (MHz)	EMISSION LEVEL (dBuV/m)	READ LEVEL (dBuV)	LIMIT (dBuV/m)	MARGIN (dB)	ANTENNA FACTOR (dB /m)	CABLE LOSS (dB)	PREAMP FACTOR (dB)	ANTENNA HEIGHT (cm)	TABLE ANGLE (Degree)	REMARK
5785	104.55	105.21	/	/	34.94	9.9	45.5	100	340	Peak
5785	97.72	98.38	/	/	34.94	9.9	45.5	100	340	Average

REMARKS:

- Emission Level = Read Level+ Antenna Factor + Cable Loss- Preamp Factor
Margin value = Emission level – Limit value.
- 5785MHz: Fundamental frequency.



Oobe Data

802.11a

ANTENNA POLARITY & TEST DISTANCE: HORIZONTAL AT 3 M											
FREQ. (MHz)	EMISSION LEVEL (dBuV/m)	READ LEVEL (dBuV)	LIMIT (dBuV/m)	MARGIN (dB)	ANTENNA FACTOR (dB /m)	CABLE LOSS (dB)	PREAMP FACTOR (dB)	ANTENNA HEIGHT (cm)	TABLE ANGLE (Degree)	REMARK	
5569	58	58.8	68.2	-10.2	34.88	9.82	45.5	100	0	Peak	
5976.55	57.55	57.72	68.2	-10.65	35.37	9.96	45.5	100	0	Peak	
ANTENNA POLARITY & TEST DISTANCE: VERTICAL AT 3 M											
FREQ. (MHz)	EMISSION LEVEL (dBuV/m)	READ LEVEL (dBuV)	LIMIT (dBuV/m)	MARGIN (dB)	ANTENNA FACTOR (dB /m)	CABLE LOSS (dB)	PREAMP FACTOR (dB)	ANTENNA HEIGHT (cm)	TABLE ANGLE (Degree)	REMARK	
5562.35	57.46	58.47	68.2	-10.74	34.67	9.82	45.5	100	360	Peak	
6009.325	57.5	57.81	68.2	-10.7	35.21	9.98	45.5	100	360	Peak	

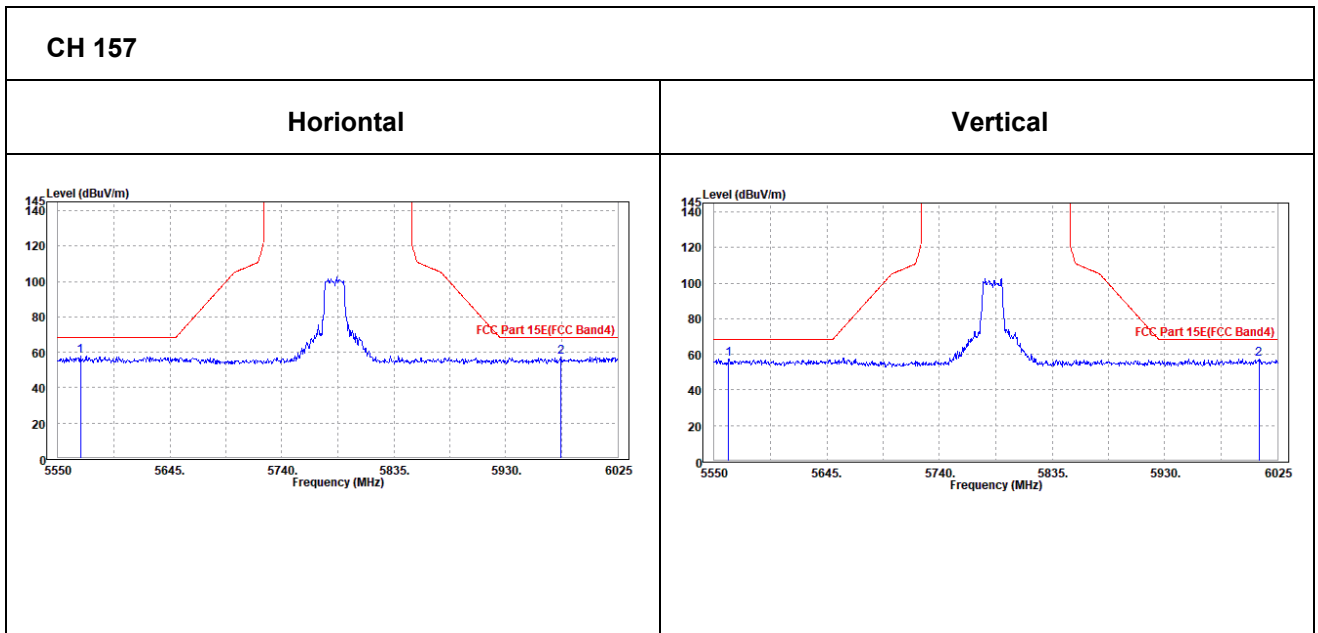



CHANNEL	TX Channel 165	DETECTOR FUNCTION	Peak (PK)
FREQUENCY RANGE	1GHz ~ 40GHz		Average (AV)

ANTENNA POLARITY & TEST DISTANCE: HORIZONTAL AT 3 M

FREQ. (MHz)	EMISSION LEVEL (dBuV/m)	READ LEVEL (dBuV)	LIMIT (dBuV/m)	MARGIN (dB)	ANTENNA FACTOR (dB /m)	CABLE LOSS (dB)	PREAMP FACTOR (dB)	ANTENNA HEIGHT (cm)	TABLE ANGLE (Degree)	REMARK
5825	104.01	104.41	/	/	35.19	9.91	45.5	105	43	Peak
5825	96.75	97.15	/	/	35.19	9.91	45.5	105	43	Average

ANTENNA POLARITY & TEST DISTANCE: VERTICAL AT 3 M

FREQ. (MHz)	EMISSION LEVEL (dBuV/m)	READ LEVEL (dBuV)	LIMIT (dBuV/m)	MARGIN (dB)	ANTENNA FACTOR (dB /m)	CABLE LOSS (dB)	PREAMP FACTOR (dB)	ANTENNA HEIGHT (cm)	TABLE ANGLE (Degree)	REMARK
5825	103.73	104.33	/	/	34.99	9.91	45.5	100	340	Peak
5825	97.51	98.11	/	/	34.99	9.91	45.5	100	340	Average

REMARKS:

- Emission Level = Read Level+ Antenna Factor + Cable Loss- Preamp Factor
Margin value = Emission level – Limit value.
- 5825MHz: Fundamental frequency.



OOBE DATA

802.11a

ANTENNA POLARITY & TEST DISTANCE: HORIZONTAL AT 3 M										
FREQ. (MHz)	EMISSION LEVEL (dBuV/m)	READ LEVEL (dBuV)	LIMIT (dBuV/m)	MARGIN (dB)	ANTENNA FACTOR (dB /m)	CABLE LOSS (dB)	PREAMP FACTOR (dB)	ANTENNA HEIGHT (cm)	TABLE ANGLE (Degree)	REMARK
5635.025	57.8	58.49	68.2	-10.4	34.96	9.85	45.5	100	360	Peak
6006.475	58.4	58.53	68.2	-9.8	35.4	9.97	45.5	100	360	Peak
ANTENNA POLARITY & TEST DISTANCE: VERTICAL AT 3 M										
FREQ. (MHz)	EMISSION LEVEL (dBuV/m)	READ LEVEL (dBuV)	LIMIT (dBuV/m)	MARGIN (dB)	ANTENNA FACTOR (dB /m)	CABLE LOSS (dB)	PREAMP FACTOR (dB)	ANTENNA HEIGHT (cm)	TABLE ANGLE (Degree)	REMARK
5582.775	57.3	58.27	68.2	-10.9	34.7	9.83	45.5	100	360	Peak
6014.075	57.84	58.13	68.2	-10.36	35.22	9.98	45.49	100	360	Peak

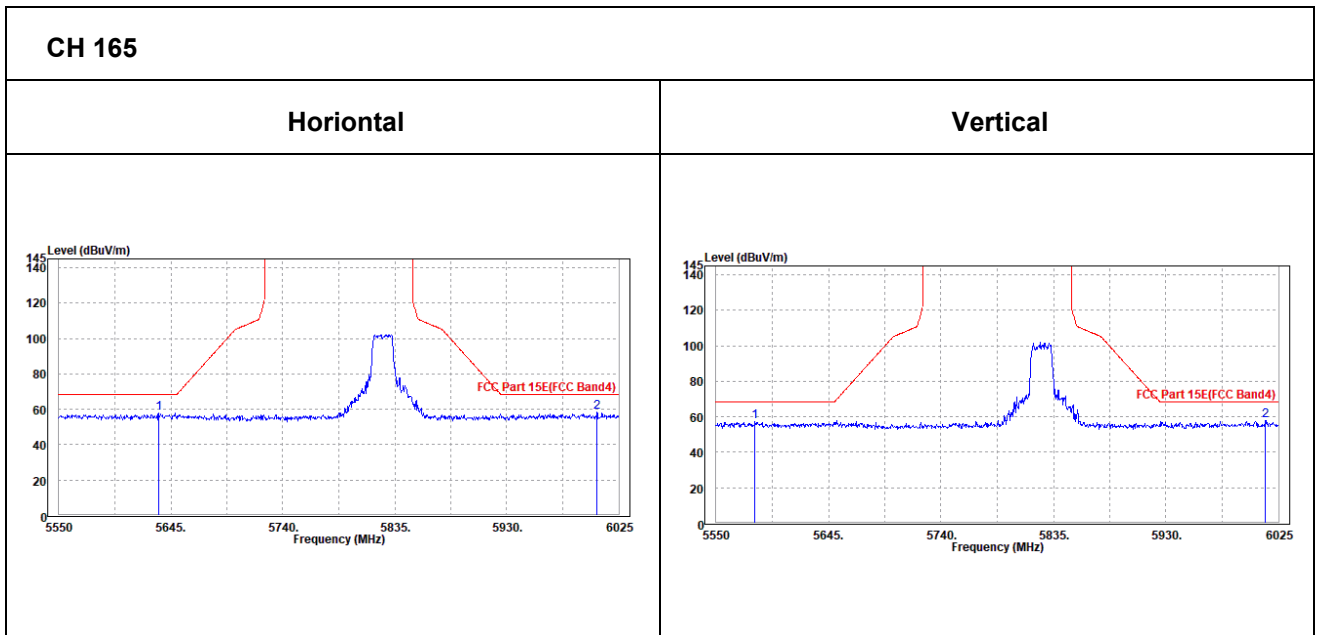



802.11n (20MHz)

CHANNEL	TX Channel 149	DETECTOR FUNCTION	Peak (PK)
FREQUENCY RANGE	1GHz ~ 40GHz		Average (AV)

ANTENNA POLARITY & TEST DISTANCE: HORIZONTAL AT 3 M										
FREQ. (MHz)	EMISSION LEVEL (dBuV/m)	READ LEVEL (dBuV)	LIMIT (dBuV/m)	MARGIN (dB)	ANTENNA FACTOR (dB /m)	CABLE LOSS (dB)	PREAMP FACTOR (dB)	ANTENNA HEIGHT (cm)	TABLE ANGLE (Degree)	REMARK
5745	102.16	102.69	/	/	35.09	9.88	45.5	100	43	Peak
5745	96.19	96.72	/	/	35.09	9.88	45.5	100	43	Average
ANTENNA POLARITY & TEST DISTANCE: VERTICAL AT 3 M										
FREQ. (MHz)	EMISSION LEVEL (dBuV/m)	READ LEVEL (dBuV)	LIMIT (dBuV/m)	MARGIN (dB)	ANTENNA FACTOR (dB /m)	CABLE LOSS (dB)	PREAMP FACTOR (dB)	ANTENNA HEIGHT (cm)	TABLE ANGLE (Degree)	REMARK
5745	102.88	103.61	/	/	34.89	9.88	45.5	100	340	Peak
5745	96.91	97.64	/	/	34.89	9.88	45.5	100	340	Average

REMARKS:

- Emission Level = Read Level+ Antenna Factor + Cable Loss- Preamp Factor
Margin value = Emission level – Limit value.
- 5745MHz: Fundamental frequency.



OOBE DATA

802.11n (20MHZ)

ANTENNA POLARITY & TEST DISTANCE: HORIZONTAL AT 3 M										
FREQ. (MHz)	EMISSION LEVEL (dBuV/m)	READ LEVEL (dBuV)	LIMIT (dBuV/m)	MARGIN (dB)	ANTENNA FACTOR (dB /m)	CABLE LOSS (dB)	PREAMP FACTOR (dB)	ANTENNA HEIGHT (cm)	TABLE ANGLE (Degree)	REMARK
5632.65	57.92	58.61	68.2	-10.28	34.96	9.85	45.5	100	0	Peak
5986.525	57.52	57.67	68.2	-10.68	35.38	9.97	45.5	100	0	Peak
ANTENNA POLARITY & TEST DISTANCE: VERTICAL AT 3 M										
FREQ. (MHz)	EMISSION LEVEL (dBuV/m)	READ LEVEL (dBuV)	LIMIT (dBuV/m)	MARGIN (dB)	ANTENNA FACTOR (dB /m)	CABLE LOSS (dB)	PREAMP FACTOR (dB)	ANTENNA HEIGHT (cm)	TABLE ANGLE (Degree)	REMARK
5571.375	57.38	58.37	68.2	-10.82	34.69	9.82	45.5	100	360	Peak
5995.075	57.26	57.6	68.2	-10.94	35.19	9.97	45.5	100	360	Peak

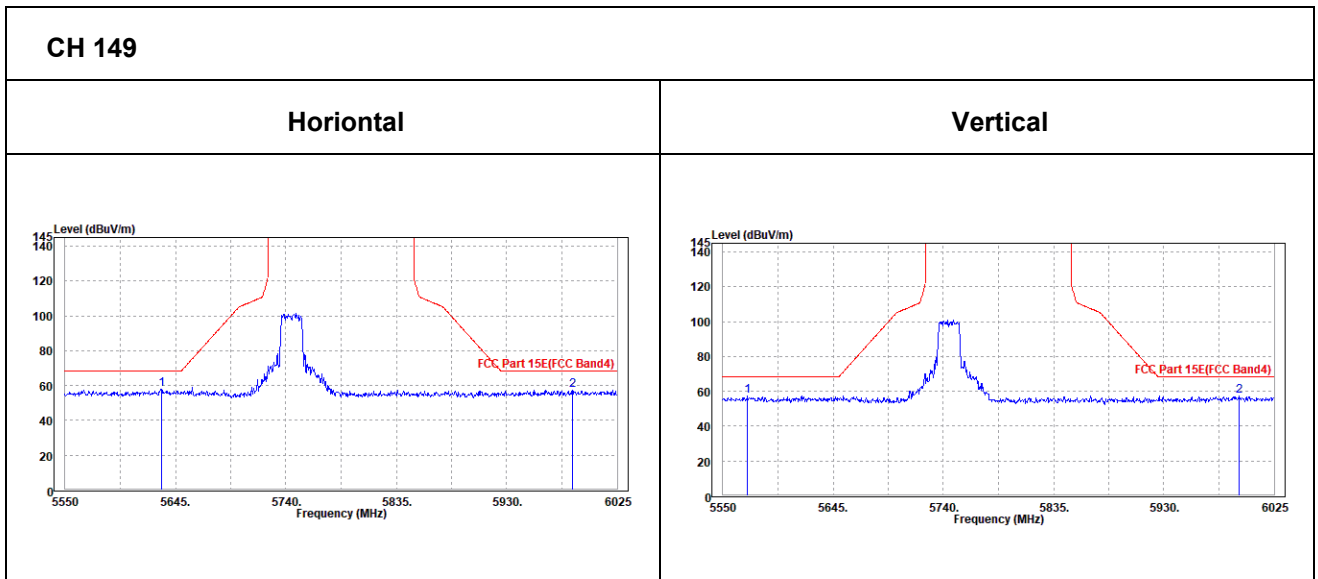



CHANNEL	TX Channel 157	DETECTOR FUNCTION	Peak (PK)
FREQUENCY RANGE	1GHz ~ 40GHz		Average (AV)

ANTENNA POLARITY & TEST DISTANCE: HORIZONTAL AT 3 M

FREQ. (MHz)	EMISSION LEVEL (dBuV/m)	READ LEVEL (dBuV)	LIMIT (dBuV/m)	MARGIN (dB)	ANTENNA FACTOR (dB /m)	CABLE LOSS (dB)	PREAMP FACTOR (dB)	ANTENNA HEIGHT (cm)	TABLE ANGLE (Degree)	REMARK
5785	102.86	103.32	/	/	35.14	9.9	45.5	100	43	Peak
5785	96.87	97.33	/	/	35.14	9.9	45.5	100	43	Average

ANTENNA POLARITY & TEST DISTANCE: VERTICAL AT 3 M

FREQ. (MHz)	EMISSION LEVEL (dBuV/m)	READ LEVEL (dBuV)	LIMIT (dBuV/m)	MARGIN (dB)	ANTENNA FACTOR (dB /m)	CABLE LOSS (dB)	PREAMP FACTOR (dB)	ANTENNA HEIGHT (cm)	TABLE ANGLE (Degree)	REMARK
5785	103.2	103.86	/	/	34.94	9.9	45.5	100	40	Peak
5785	97.02	97.68	/	/	34.94	9.9	45.5	100	40	Average

REMARKS:

- Emission Level = Read Level+ Antenna Factor + Cable Loss- Preamp Factor
Margin value = Emission level – Limit value.
- 5785MHz: Fundamental frequency.



Oobe Data

802.11n (20MHz)

ANTENNA POLARITY & TEST DISTANCE: HORIZONTAL AT 3 M										
FREQ. (MHz)	EMISSION LEVEL (dBuV/m)	READ LEVEL (dBuV)	LIMIT (dBuV /m)	MARGIN (dB)	ANTENNA FACTOR (dB /m)	CABLE LOSS (dB)	PREAMP FACTOR (dB)	ANTENNA HEIGHT (cm)	TABLE ANGLE (Degree)	REMARK
5622.675	57.93	58.64	68.2	-10.27	34.95	9.84	45.5	100	360	Peak
5996.975	58.48	58.61	68.2	-9.72	35.4	9.97	45.5	100	360	Peak
ANTENNA POLARITY & TEST DISTANCE: VERTICAL AT 3 M										
FREQ. (MHz)	EMISSION LEVEL (dBuV/m)	READ LEVEL (dBuV)	LIMIT (dBuV /m)	MARGIN (dB)	ANTENNA FACTOR (dB /m)	CABLE LOSS (dB)	PREAMP FACTOR (dB)	ANTENNA HEIGHT (cm)	TABLE ANGLE (Degree)	REMARK
5577.55	57.84	58.82	68.2	-10.36	34.69	9.83	45.5	100	0	Peak
6001.725	57.66	57.99	68.2	-10.54	35.2	9.97	45.5	100	0	Peak

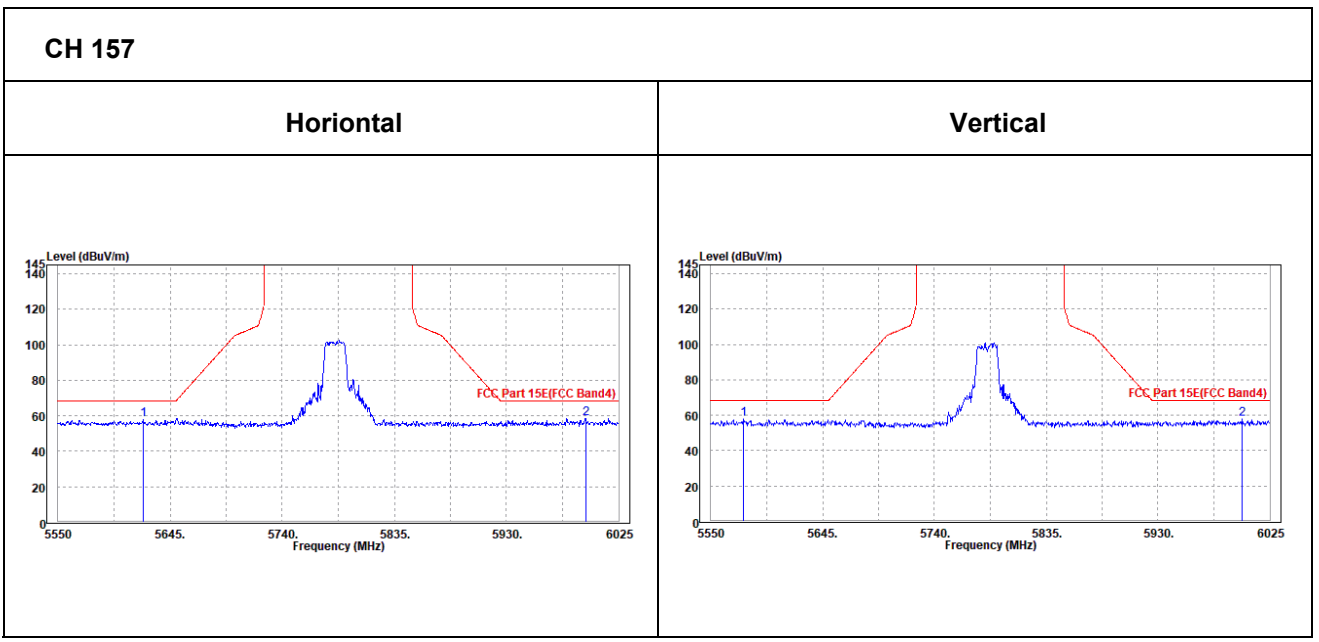



CHANNEL	TX Channel 165	DETECTOR FUNCTION	Peak (PK)
FREQUENCY RANGE	1GHz ~ 40GHz		Average (AV)

ANTENNA POLARITY & TEST DISTANCE: HORIZONTAL AT 3 M

FREQ. (MHz)	EMISSION LEVEL (dBuV/m)	READ LEVEL (dBuV)	LIMIT (dBuV/m)	MARGIN (dB)	ANTENNA FACTOR (dB /m)	CABLE LOSS (dB)	PREAMP FACTOR (dB)	ANTENNA HEIGHT (cm)	TABLE ANGLE (Degree)	REMARK
5825	102.68	103.08	/	/	35.19	9.91	45.5	100	43	Peak
5825	96.44	96.84	/	/	35.19	9.91	45.5	100	43	Average

ANTENNA POLARITY & TEST DISTANCE: VERTICAL AT 3 M

FREQ. (MHz)	EMISSION LEVEL (dBuV/m)	READ LEVEL (dBuV)	LIMIT (dBuV/m)	MARGIN (dB)	ANTENNA FACTOR (dB /m)	CABLE LOSS (dB)	PREAMP FACTOR (dB)	ANTENNA HEIGHT (cm)	TABLE ANGLE (Degree)	REMARK
5825	102.58	103.18	/	/	34.99	9.91	45.5	100	340	Peak
5825	96.37	96.97	/	/	34.99	9.91	45.5	100	340	Average

REMARKS:

- Emission Level = Read Level+ Antenna Factor + Cable Loss- Preamp Factor
Margin value = Emission level – Limit value.
- 5825MHz: Fundamental frequency.



OBE DATA

802.11n (20MHz)

ANTENNA POLARITY & TEST DISTANCE: HORIZONTAL AT 3 M										
FREQ. (MHz)	EMISSION LEVEL (dBuV/m)	READ LEVEL (dBuV)	LIMIT (dBuV/m)	MARGIN (dB)	ANTENNA FACTOR (dB /m)	CABLE LOSS (dB)	PREAMP FACTOR (dB)	ANTENNA HEIGHT (cm)	TABLE ANGLE (Degree)	REMARK
5578.5	57.71	58.49	68.2	-10.49	34.89	9.83	45.5	100	0	Peak
5954.225	57.8	58	68.2	-10.4	35.35	9.95	45.5	100	0	Peak
ANTENNA POLARITY & TEST DISTANCE: VERTICAL AT 3 M										
FREQ. (MHz)	EMISSION LEVEL (dBuV/m)	READ LEVEL (dBuV)	LIMIT (dBuV/m)	MARGIN (dB)	ANTENNA FACTOR (dB /m)	CABLE LOSS (dB)	PREAMP FACTOR (dB)	ANTENNA HEIGHT (cm)	TABLE ANGLE (Degree)	REMARK
5583.725	57.93	58.9	68.2	-10.27	34.7	9.83	45.5	100	360	Peak
5978.925	57.76	58.13	68.2	-10.44	35.17	9.96	45.5	100	360	Peak

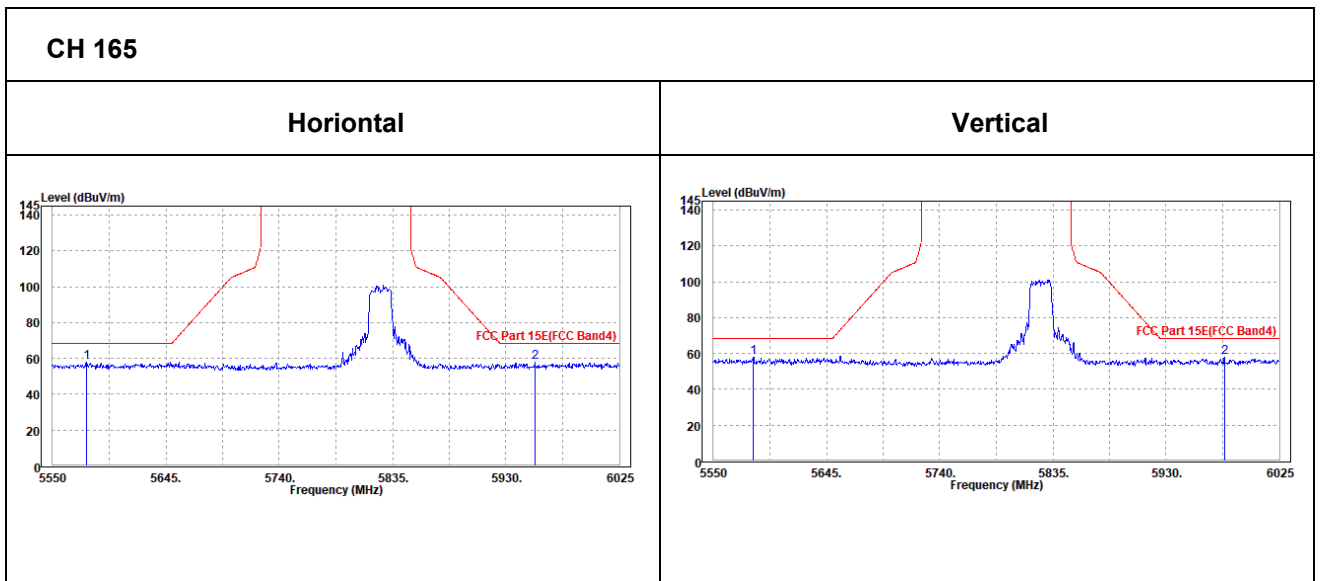



802.11n (40MHz)

CHANNEL	TX Channel 151	DETECTOR FUNCTION	Peak (PK)
FREQUENCY RANGE	1GHz ~ 40GHz		Average (AV)

ANTENNA POLARITY & TEST DISTANCE: HORIZONTAL AT 3 M

FREQ. (MHz)	EMISSION LEVEL (dBuV/m)	READ LEVEL (dBuV)	LIMIT (dBuV/m)	MARGIN (dB)	ANTENNA FACTOR (dB /m)	CABLE LOSS (dB)	PREAMP FACTOR (dB)	ANTENNA HEIGHT (cm)	TABLE ANGLE (Degree)	REMARK
5755	98.61	99.11	/	/	35.11	9.89	45.5	100	43	Peak
5755	93.73	94.23	/	/	35.11	9.89	45.5	100	43	Average

ANTENNA POLARITY & TEST DISTANCE: VERTICAL AT 3 M

FREQ. (MHz)	EMISSION LEVEL (dBuV/m)	READ LEVEL (dBuV)	LIMIT (dBuV/m)	MARGIN (dB)	ANTENNA FACTOR (dB /m)	CABLE LOSS (dB)	PREAMP FACTOR (dB)	ANTENNA HEIGHT (cm)	TABLE ANGLE (Degree)	REMARK
5755	97.5	98.2	/	/	34.91	9.89	45.5	100	340	Peak
5755	93.92	94.62	/	/	34.91	9.89	45.5	100	340	Average

REMARKS:

- Emission Level = Read Level+ Antenna Factor + Cable Loss- Preamp Factor
Margin value = Emission level – Limit value.
- 5755MHz: Fundamental frequency.



OBE DATA

802.11n (40MHZ)

ANTENNA POLARITY & TEST DISTANCE: HORIZONTAL AT 3 M										
FREQ. (MHz)	EMISSION LEVEL (dBuV/m)	READ LEVEL (dBuV)	LIMIT (dBuV/m)	MARGIN (dB)	ANTENNA FACTOR (dB /m)	CABLE LOSS (dB)	PREAMP FACTOR (dB)	ANTENNA HEIGHT (cm)	TABLE ANGLE (Degree)	REMARK
5585.15	56.73	57.5	68.2	-11.47	34.9	9.83	45.5	100	360	Peak
5982.725	57.1	57.26	68.2	-11.1	35.38	9.96	45.5	100	360	Peak
ANTENNA POLARITY & TEST DISTANCE: VERTICAL AT 3 M										
FREQ. (MHz)	EMISSION LEVEL (dBuV/m)	READ LEVEL (dBuV)	LIMIT (dBuV/m)	MARGIN (dB)	ANTENNA FACTOR (dB /m)	CABLE LOSS (dB)	PREAMP FACTOR (dB)	ANTENNA HEIGHT (cm)	TABLE ANGLE (Degree)	REMARK
5633.125	56.9	57.79	68.2	-11.3	34.76	9.85	45.5	100	0	Peak
5990.8	58.42	58.76	68.2	-9.78	35.19	9.97	45.5	100	0	Peak

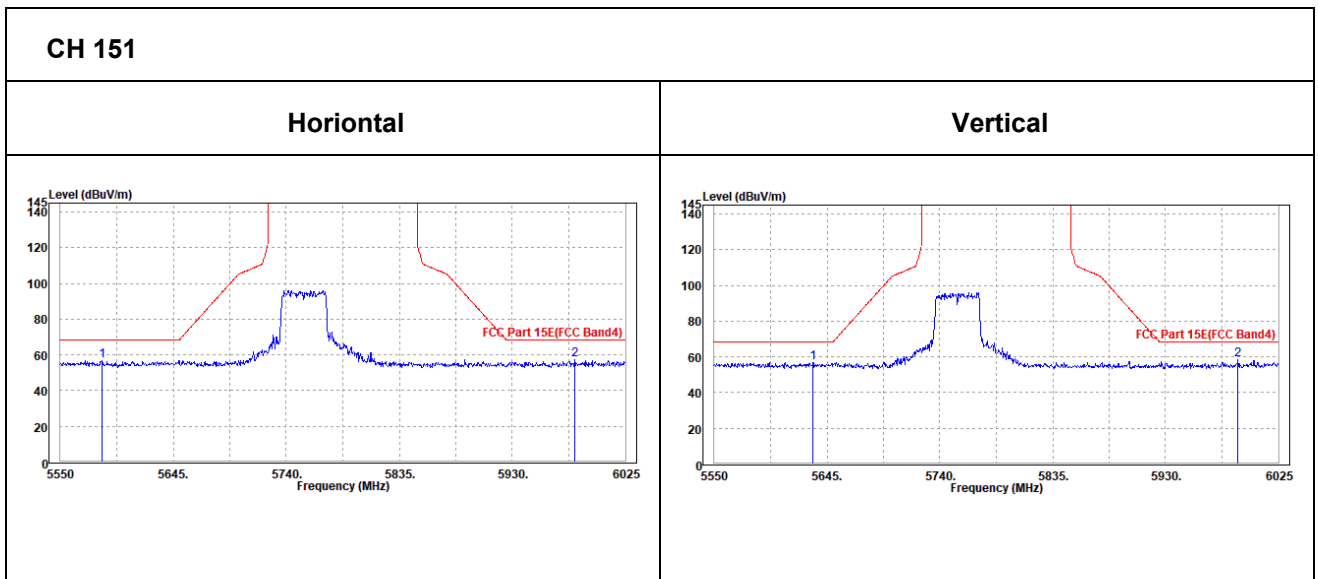



CHANNEL	TX Channel 159	DETECTOR FUNCTION	Peak (PK)
FREQUENCY RANGE	1GHz ~ 40GHz		Average (AV)

ANTENNA POLARITY & TEST DISTANCE: HORIZONTAL AT 3 M

FREQ. (MHz)	EMISSION LEVEL (dBuV/m)	READ LEVEL (dBuV)	LIMIT (dBuV/m)	MARGIN (dB)	ANTENNA FACTOR (dB /m)	CABLE LOSS (dB)	PREAMP FACTOR (dB)	ANTENNA HEIGHT (cm)	TABLE ANGLE (Degree)	REMARK
5795	98.39	98.84	/	/	35.15	9.9	45.5	100	43	Peak
5795	93.45	93.9	/	/	35.15	9.9	45.5	100	43	Average

ANTENNA POLARITY & TEST DISTANCE: VERTICAL AT 3 M

FREQ. (MHz)	EMISSION LEVEL (dBuV/m)	READ LEVEL (dBuV)	LIMIT (dBuV/m)	MARGIN (dB)	ANTENNA FACTOR (dB /m)	CABLE LOSS (dB)	PREAMP FACTOR (dB)	ANTENNA HEIGHT (cm)	TABLE ANGLE (Degree)	REMARK
5795	98.26	98.91	/	/	34.95	9.9	45.5	100	340	Peak
5795	93.47	94.12	/	/	34.95	9.9	45.5	100	340	Average

REMARKS:

- Emission Level = Read Level+ Antenna Factor + Cable Loss- Preamp Factor
Margin value = Emission level – Limit value.
- 5795MHz: Fundamental frequency.



Oobe Data

802.11n (40MHz)

ANTENNA POLARITY & TEST DISTANCE: HORIZONTAL AT 3 M										
FREQ. (MHz)	EMISSION LEVEL (dBuV/m)	READ LEVEL (dBuV)	LIMIT (dBuV/m)	MARGIN (dB)	ANTENNA FACTOR (dB /m)	CABLE LOSS (dB)	PREAMP FACTOR (dB)	ANTENNA HEIGHT (cm)	TABLE ANGLE (Degree)	REMARK
5581.35	56.68	57.45	68.2	-11.52	34.9	9.83	45.5	100	0	Peak
5978.925	57.43	57.6	68.2	-10.77	35.37	9.96	45.5	100	0	Peak
ANTENNA POLARITY & TEST DISTANCE: VERTICAL AT 3 M										
FREQ. (MHz)	EMISSION LEVEL (dBuV/m)	READ LEVEL (dBuV)	LIMIT (dBuV/m)	MARGIN (dB)	ANTENNA FACTOR (dB /m)	CABLE LOSS (dB)	PREAMP FACTOR (dB)	ANTENNA HEIGHT (cm)	TABLE ANGLE (Degree)	REMARK
5607.95	56.59	57.52	68.2	-11.61	34.73	9.84	45.5	100	360	Peak
6001.725	57.23	57.56	68.2	-10.97	35.2	9.97	45.5	100	360	Peak

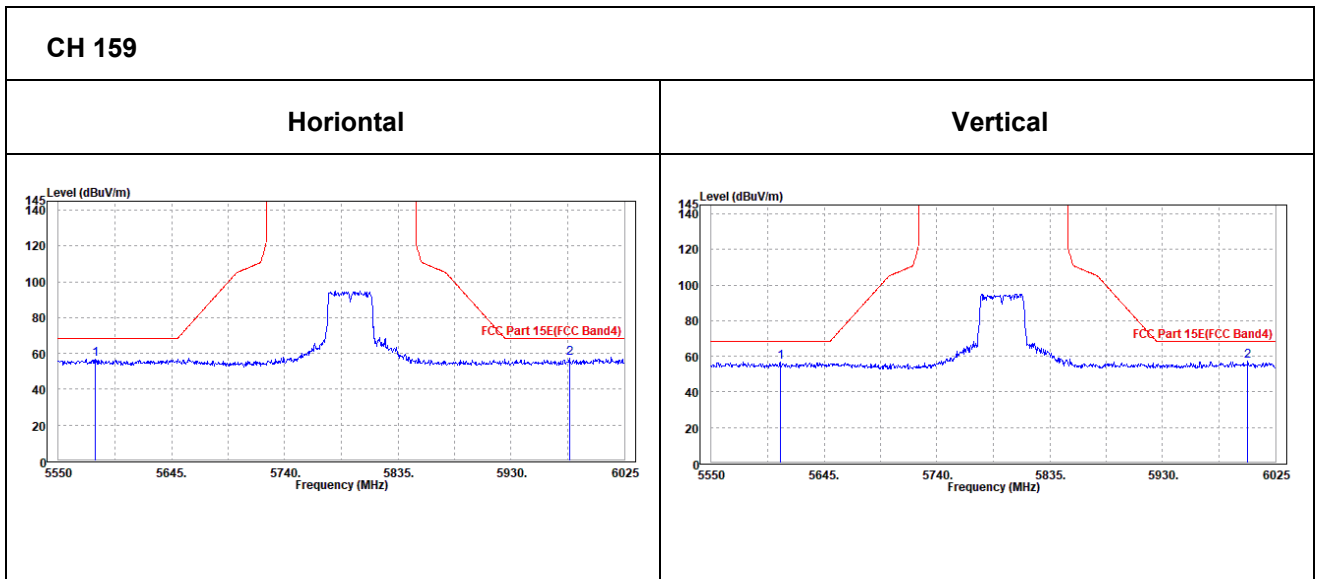



802.11ac (20MHz)

CHANNEL	TX Channel 149	DETECTOR FUNCTION	Peak (PK)
FREQUENCY RANGE	1GHz ~ 40GHz		Average (AV)

ANTENNA POLARITY & TEST DISTANCE: HORIZONTAL AT 3 M

FREQ. (MHz)	EMISSION LEVEL (dBuV/m)	READ LEVEL (dBuV)	LIMIT (dBuV/m)	MARGIN (dB)	ANTENNA FACTOR (dB /m)	CABLE LOSS (dB)	PREAMP FACTOR (dB)	ANTENNA HEIGHT (cm)	TABLE ANGLE (Degree)	REMARK
5745	103.33	103.86	/	/	35.09	9.88	45.5	100	43	Peak
5745	96.65	97.18	/	/	35.09	9.88	45.5	100	43	Average

ANTENNA POLARITY & TEST DISTANCE: VERTICAL AT 3 M

FREQ. (MHz)	EMISSION LEVEL (dBuV/m)	READ LEVEL (dBuV)	LIMIT (dBuV/m)	MARGIN (dB)	ANTENNA FACTOR (dB /m)	CABLE LOSS (dB)	PREAMP FACTOR (dB)	ANTENNA HEIGHT (cm)	TABLE ANGLE (Degree)	REMARK
5745	104.11	104.84	/	/	34.89	9.88	45.5	100	340	Peak
5745	97.15	97.88	/	/	34.89	9.88	45.5	100	340	Average

REMARKS:

- Emission Level = Read Level+ Antenna Factor + Cable Loss- Preamp Factor
Margin value = Emission level – Limit value.
- 5745MHz: Fundamental frequency.



OOBE DATA

802.11ac (20MHZ)

ANTENNA POLARITY & TEST DISTANCE: HORIZONTAL AT 3 M										
FREQ. (MHz)	EMISSION LEVEL (dBuV/m)	READ LEVEL (dBuV)	LIMIT (dBuV/m)	MARGIN (dB)	ANTENNA FACTOR (dB /m)	CABLE LOSS (dB)	PREAMP FACTOR (dB)	ANTENNA HEIGHT (cm)	TABLE ANGLE (Degree)	REMARK
5624.1	57.07	57.78	68.2	-11.13	34.95	9.84	45.5	100	360	Peak
6004.575	57.26	57.39	68.2	-10.94	35.4	9.97	45.5	100	360	Average
ANTENNA POLARITY & TEST DISTANCE: VERTICAL AT 3 M										
FREQ. (MHz)	EMISSION LEVEL (dBuV/m)	READ LEVEL (dBuV)	LIMIT (dBuV/m)	MARGIN (dB)	ANTENNA FACTOR (dB /m)	CABLE LOSS (dB)	PREAMP FACTOR (dB)	ANTENNA HEIGHT (cm)	TABLE ANGLE (Degree)	REMARK
5601.3	56.93	57.88	68.2	-11.27	34.72	9.83	45.5	100	0	Peak
5949	56.77	57.18	68.2	-11.43	35.14	9.95	45.5	100	0	Average

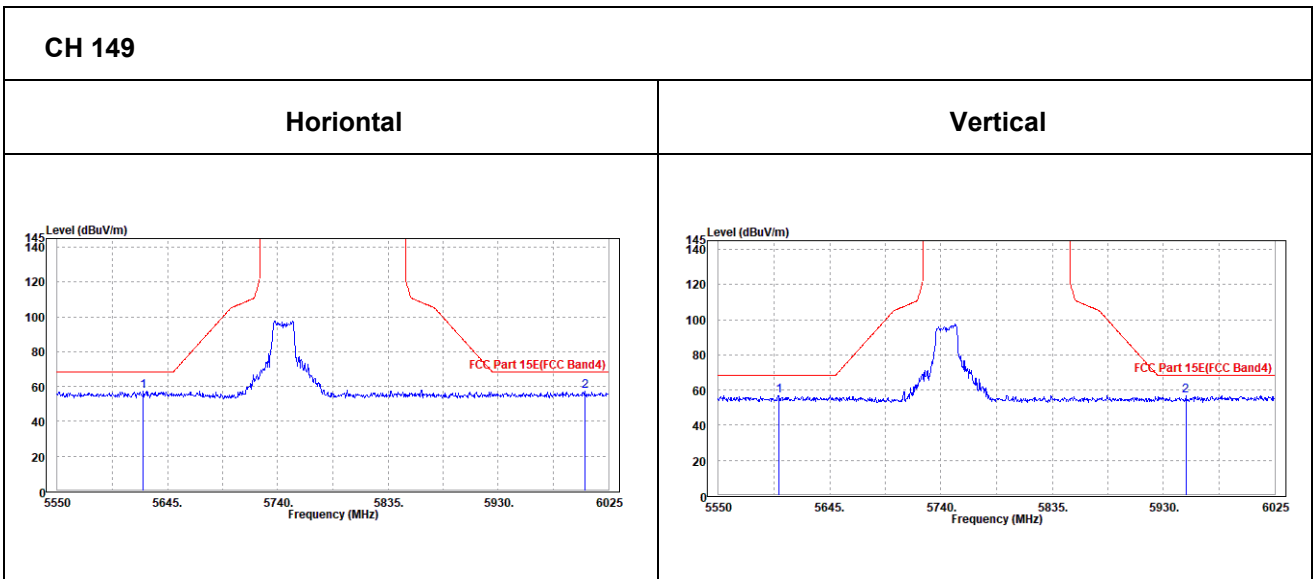



CHANNEL	TX Channel 157	DETECTOR FUNCTION	Peak (PK)
FREQUENCY RANGE	1GHz ~ 40GHz		Average (AV)

ANTENNA POLARITY & TEST DISTANCE: HORIZONTAL AT 3 M

FREQ. (MHz)	EMISSION LEVEL (dBuV/m)	READ LEVEL (dBuV)	LIMIT (dBuV/m)	MARGIN (dB)	ANTENNA FACTOR (dB /m)	CABLE LOSS (dB)	PREAMP FACTOR (dB)	ANTENNA HEIGHT (cm)	TABLE ANGLE (Degree)	REMARK
5785	103.69	104.15	/	/	35.14	9.9	45.5	100	43	Peak
5785	96.42	96.88	/	/	35.14	9.9	45.5	100	43	Average

ANTENNA POLARITY & TEST DISTANCE: VERTICAL AT 3 M

FREQ. (MHz)	EMISSION LEVEL (dBuV/m)	READ LEVEL (dBuV)	LIMIT (dBuV/m)	MARGIN (dB)	ANTENNA FACTOR (dB /m)	CABLE LOSS (dB)	PREAMP FACTOR (dB)	ANTENNA HEIGHT (cm)	TABLE ANGLE (Degree)	REMARK
5785	104.2	104.86	/	/	34.94	9.9	45.5	100	340	Peak
5785	96.76	97.42	/	/	34.94	9.9	45.5	100	340	Average

REMARKS:

- Emission Level = Read Level+ Antenna Factor + Cable Loss- Preamp Factor
Margin value = Emission level – Limit value.
- 5785MHz: Fundamental frequency.



OBE DATA

802.11ac (20MHZ)

ANTENNA POLARITY & TEST DISTANCE: HORIZONTAL AT 3 M										
FREQ. (MHz)	EMISSION LEVEL (dBuV/m)	READ LEVEL (dBuV)	LIMIT (dBuV /m)	MARGIN (dB)	ANTENNA FACTOR (dB /m)	CABLE LOSS (dB)	PREAMP FACTOR (dB)	ANTENNA HEIGHT (cm)	TABLE ANGLE (Degree)	REMARK
5644.05	59.17	59.85	68.2	-9.03	34.97	9.85	45.5	100	0	Peak
5930.95	57.4	57.63	68.2	-10.8	35.32	9.95	45.5	100	0	Peak
ANTENNA POLARITY & TEST DISTANCE: VERTICAL AT 3 M										
FREQ. (MHz)	EMISSION LEVEL (dBuV/m)	READ LEVEL (dBuV)	LIMIT (dBuV /m)	MARGIN (dB)	ANTENNA FACTOR (dB /m)	CABLE LOSS (dB)	PREAMP FACTOR (dB)	ANTENNA HEIGHT (cm)	TABLE ANGLE (Degree)	REMARK
5628.375	57.27	58.18	68.2	-10.93	34.75	9.84	45.5	100	360	Peak
5999.35	57.1	57.43	68.2	-11.1	35.2	9.97	45.5	100	360	Peak

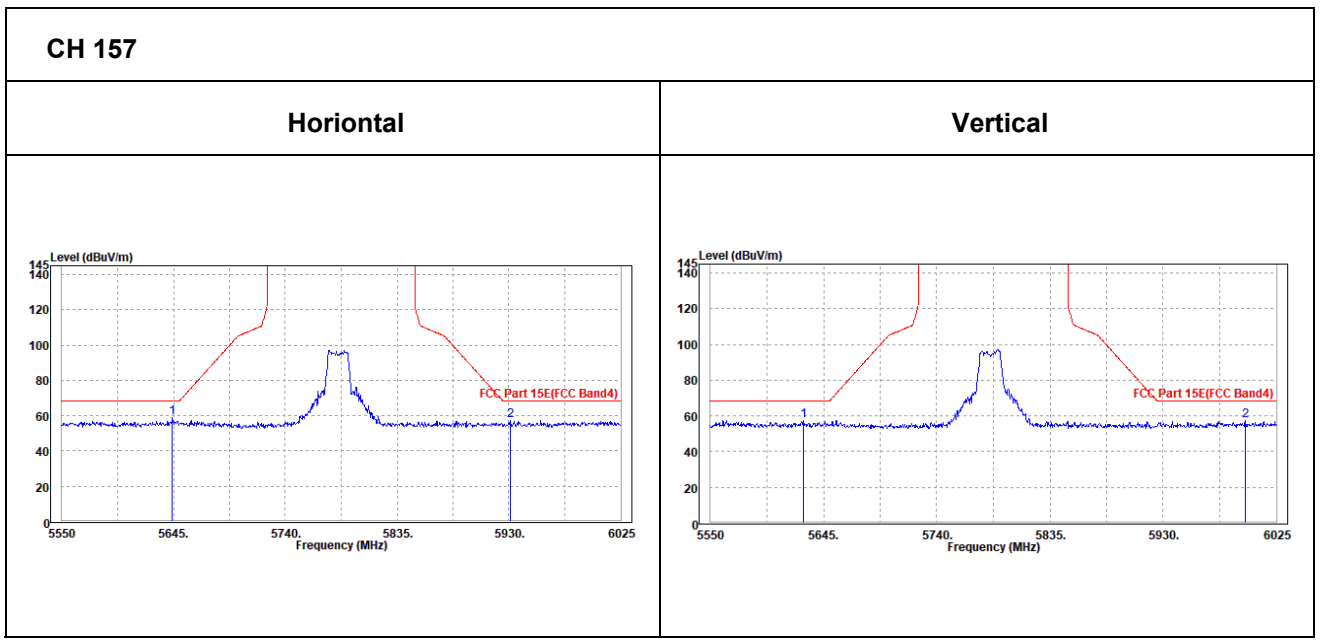



CHANNEL	TX Channel 165	DETECTOR FUNCTION	Peak (PK)
FREQUENCY RANGE	1GHz ~ 40GHz		Average (AV)

ANTENNA POLARITY & TEST DISTANCE: HORIZONTAL AT 3 M

FREQ. (MHz)	EMISSION LEVEL (dBuV/m)	READ LEVEL (dBuV)	LIMIT (dBuV/m)	MARGIN (dB)	ANTENNA FACTOR (dB /m)	CABLE LOSS (dB)	PREAMP FACTOR (dB)	ANTENNA HEIGHT (cm)	TABLE ANGLE (Degree)	REMARK
5825	103.19	103.59	/	/	35.19	9.91	45.5	100	43	Peak
5825	95.95	96.35	/	/	35.19	9.91	45.5	100	43	Average

ANTENNA POLARITY & TEST DISTANCE: VERTICAL AT 3 M

FREQ. (MHz)	EMISSION LEVEL (dBuV/m)	READ LEVEL (dBuV)	LIMIT (dBuV/m)	MARGIN (dB)	ANTENNA FACTOR (dB /m)	CABLE LOSS (dB)	PREAMP FACTOR (dB)	ANTENNA HEIGHT (cm)	TABLE ANGLE (Degree)	REMARK
5825	104	104.6	/	/	34.99	9.91	45.5	100	340	Peak
5825	96.59	97.19	/	/	34.99	9.91	45.5	100	340	Average

REMARKS:

- Emission Level = Read Level+ Antenna Factor + Cable Loss- Preamp Factor
Margin value = Emission level – Limit value.
- 5825MHz: Fundamental frequency.



Oobe Data

802.11ac (20MHz)

ANTENNA POLARITY & TEST DISTANCE: HORIZONTAL AT 3 M										
FREQ. (MHz)	EMISSION LEVEL (dBuV/m)	READ LEVEL (dBuV)	LIMIT (dBuV/m)	MARGIN (dB)	ANTENNA FACTOR (dB /m)	CABLE LOSS (dB)	PREAMP FACTOR (dB)	ANTENNA HEIGHT (cm)	TABLE ANGLE (Degree)	REMARK
5571.375	58.36	59.15	68.2	-9.84	34.89	9.82	45.5	100	360	Peak
5960.4	57.42	57.61	68.2	-10.78	35.35	9.96	45.5	100	360	Peak
ANTENNA POLARITY & TEST DISTANCE: VERTICAL AT 3 M										
FREQ. (MHz)	EMISSION LEVEL (dBuV/m)	READ LEVEL (dBuV)	LIMIT (dBuV/m)	MARGIN (dB)	ANTENNA FACTOR (dB /m)	CABLE LOSS (dB)	PREAMP FACTOR (dB)	ANTENNA HEIGHT (cm)	TABLE ANGLE (Degree)	REMARK
5635.975	57.11	58	68.2	-11.09	34.76	9.85	45.5	100	0	Peak
5956.6	57.47	57.86	68.2	-10.73	35.15	9.96	45.5	100	0	Peak

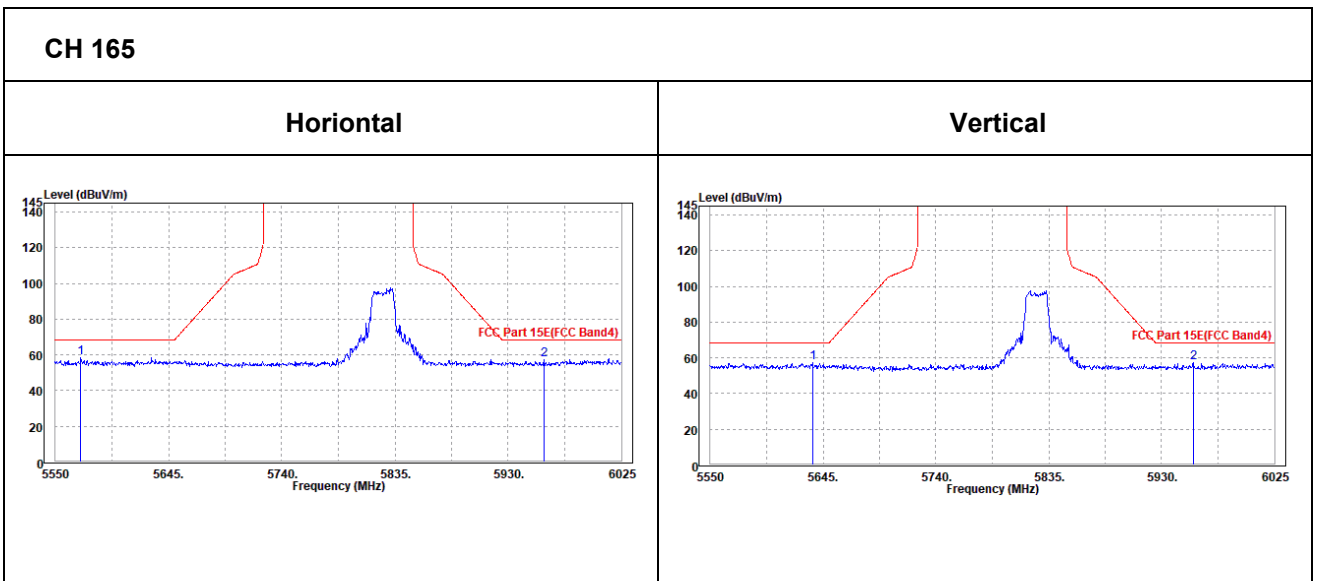



802.11ac (40MHz)

CHANNEL	TX Channel 151	DETECTOR FUNCTION	Peak (PK)
FREQUENCY RANGE	1GHz ~ 40GHz		Average (AV)

ANTENNA POLARITY & TEST DISTANCE: HORIZONTAL AT 3 M

FREQ. (MHz)	EMISSION LEVEL (dBuV/m)	READ LEVEL (dBuV)	LIMIT (dBuV/m)	MARGIN (dB)	ANTENNA FACTOR (dB /m)	CABLE LOSS (dB)	PREAMP FACTOR (dB)	ANTENNA HEIGHT (cm)	TABLE ANGLE (Degree)	REMARK
5755	97.58	98.08	/	/	35.11	9.89	45.5	100	43	Peak
5755	93.83	94.33	/	/	35.11	9.89	45.5	100	43	Average

ANTENNA POLARITY & TEST DISTANCE: VERTICAL AT 3 M

FREQ. (MHz)	EMISSION LEVEL (dBuV/m)	READ LEVEL (dBuV)	LIMIT (dBuV/m)	MARGIN (dB)	ANTENNA FACTOR (dB /m)	CABLE LOSS (dB)	PREAMP FACTOR (dB)	ANTENNA HEIGHT (cm)	TABLE ANGLE (Degree)	REMARK
5755	97.53	98.23	/	/	34.91	9.89	45.5	100	340	Peak
5755	94.18	94.88	/	/	34.91	9.89	45.5	100	340	Average

REMARKS:

- Emission Level = Read Level+ Antenna Factor + Cable Loss- Preamp Factor
Margin value = Emission level – Limit value.
- 5755MHz: Fundamental frequency.



Oobe Data

802.11ac (40MHz)

ANTENNA POLARITY & TEST DISTANCE: HORIZONTAL AT 3 M										
FREQ. (MHz)	EMISSION LEVEL (dBuV/m)	READ LEVEL (dBuV)	LIMIT (dBuV/m)	MARGIN (dB)	ANTENNA FACTOR (dB /m)	CABLE LOSS (dB)	PREAMP FACTOR (dB)	ANTENNA HEIGHT (cm)	TABLE ANGLE (Degree)	REMARK
5636.925	57.32	58.01	68.2	-10.88	34.96	9.85	45.5	100	0	Peak
5992.225	56.7	56.84	68.2	-11.5	35.39	9.97	45.5	100	0	Peak
ANTENNA POLARITY & TEST DISTANCE: VERTICAL AT 3 M										
FREQ. (MHz)	EMISSION LEVEL (dBuV/m)	READ LEVEL (dBuV)	LIMIT (dBuV/m)	MARGIN (dB)	ANTENNA FACTOR (dB /m)	CABLE LOSS (dB)	PREAMP FACTOR (dB)	ANTENNA HEIGHT (cm)	TABLE ANGLE (Degree)	REMARK
5577.55	57.59	58.57	68.2	-10.61	34.69	9.83	45.5	100	360	Peak
6008.375	57.13	57.44	68.2	-11.07	35.21	9.98	45.5	100	360	Peak

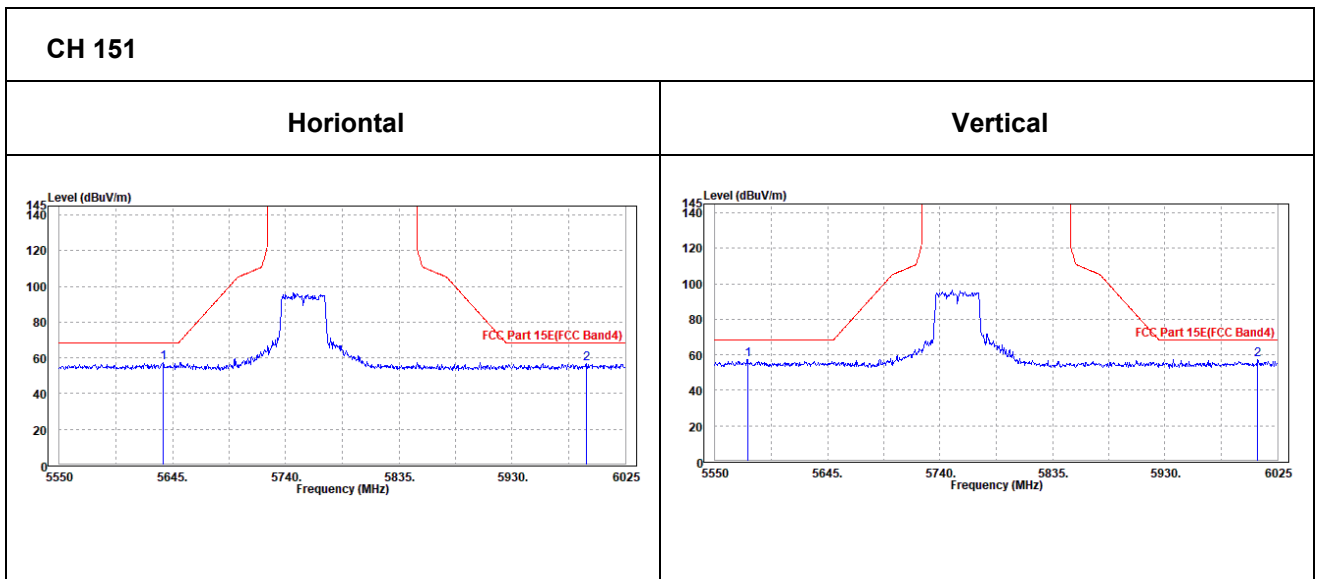



CHANNEL	TX Channel 159	DETECTOR FUNCTION	Peak (PK)
FREQUENCY RANGE	1GHz ~ 40GHz		Average (AV)

ANTENNA POLARITY & TEST DISTANCE: HORIZONTAL AT 3 M

FREQ. (MHz)	EMISSION LEVEL (dBuV/m)	READ LEVEL (dBuV)	LIMIT (dBuV/m)	MARGIN (dB)	ANTENNA FACTOR (dB /m)	CABLE LOSS (dB)	PREAMP FACTOR (dB)	ANTENNA HEIGHT (cm)	TABLE ANGLE (Degree)	REMARK
5795	97.77	98.22	/	/	35.15	9.9	45.5	100	43	Peak
5795	93.83	94.28	/	/	35.15	9.9	45.5	100	43	Average

ANTENNA POLARITY & TEST DISTANCE: VERTICAL AT 3 M

FREQ. (MHz)	EMISSION LEVEL (dBuV/m)	READ LEVEL (dBuV)	LIMIT (dBuV/m)	MARGIN (dB)	ANTENNA FACTOR (dB /m)	CABLE LOSS (dB)	PREAMP FACTOR (dB)	ANTENNA HEIGHT (cm)	TABLE ANGLE (Degree)	REMARK
5795	98.64	99.29	/	/	34.95	9.9	45.5	100	340	Peak
5795	94.45	95.1	/	/	34.95	9.9	45.5	100	340	Average

REMARKS:

- Emission Level = Read Level+ Antenna Factor + Cable Loss- Preamp Factor
Margin value = Emission level – Limit value.
- 5795MHz: Fundamental frequency.



Oobe Data

802.11ac (40MHz)

ANTENNA POLARITY & TEST DISTANCE: HORIZONTAL AT 3 M										
FREQ. (MHz)	EMISSION LEVEL (dBuV/m)	READ LEVEL (dBuV)	LIMIT (dBuV/m)	MARGIN (dB)	ANTENNA FACTOR (dB /m)	CABLE LOSS (dB)	PREAMP FACTOR (dB)	ANTENNA HEIGHT (cm)	TABLE ANGLE (Degree)	REMARK
5636.45	56.97	57.66	68.2	-11.23	34.96	9.85	45.5	100	360	Peak
6017.4	58.07	58.18	68.2	-10.13	35.4	9.98	45.49	100	360	Peak
ANTENNA POLARITY & TEST DISTANCE: VERTICAL AT 3 M										
FREQ. (MHz)	EMISSION LEVEL (dBuV/m)	READ LEVEL (dBuV)	LIMIT (dBuV/m)	MARGIN (dB)	ANTENNA FACTOR (dB /m)	CABLE LOSS (dB)	PREAMP FACTOR (dB)	ANTENNA HEIGHT (cm)	TABLE ANGLE (Degree)	REMARK
5594.65	57.18	58.14	68.2	-11.02	34.71	9.83	45.5	100	0	Peak
5957.075	56.53	56.92	68.2	-11.67	35.15	9.96	45.5	100	0	Peak

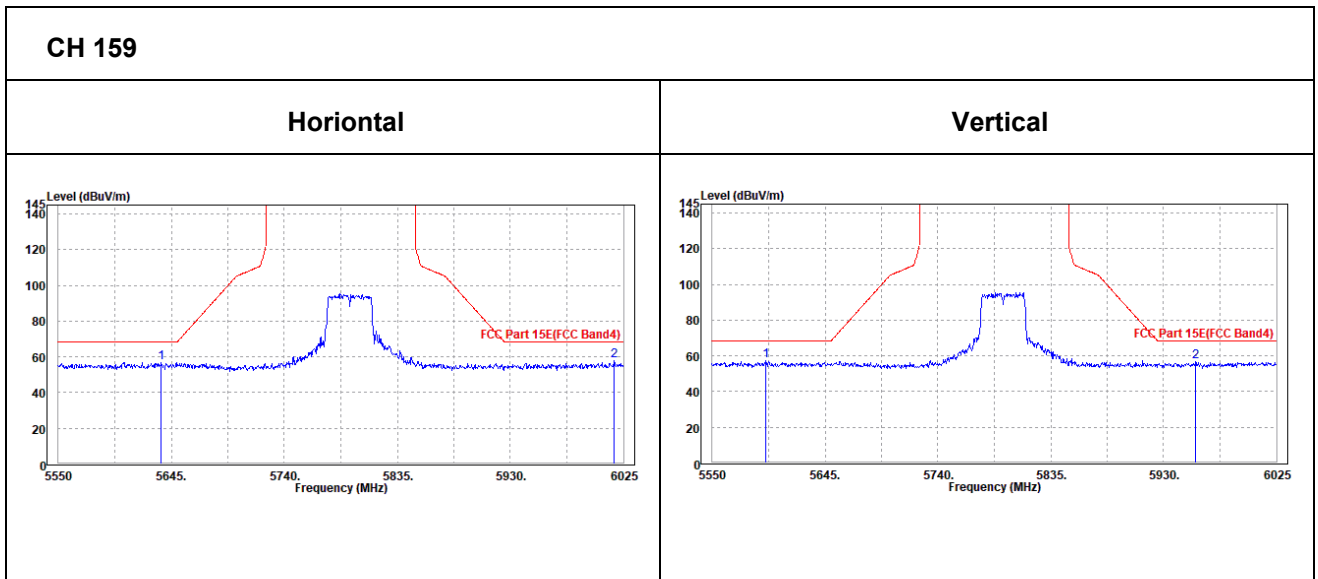



802.11ac (80MHz)

CHANNEL	TX Channel 155	DETECTOR FUNCTION	Peak (PK)
FREQUENCY RANGE	1GHz ~ 40GHz		Average (AV)

ANTENNA POLARITY & TEST DISTANCE: HORIZONTAL AT 3 M

FREQ. (MHz)	EMISSION LEVEL (dBuV/m)	READ LEVEL (dBuV)	LIMIT (dBuV/m)	MARGIN (dB)	ANTENNA FACTOR (dB /m)	CABLE LOSS (dB)	PREAMP FACTOR (dB)	ANTENNA HEIGHT (cm)	TABLE ANGLE (Degree)	REMARK
5775	95.07	95.55	/	/	35.13	9.89	45.5	100	43	Peak
5775	91.28	91.76	/	/	35.13	9.89	45.5	100	43	Average

ANTENNA POLARITY & TEST DISTANCE: VERTICAL AT 3 M

FREQ. (MHz)	EMISSION LEVEL (dBuV/m)	READ LEVEL (dBuV)	LIMIT (dBuV/m)	MARGIN (dB)	ANTENNA FACTOR (dB /m)	CABLE LOSS (dB)	PREAMP FACTOR (dB)	ANTENNA HEIGHT (cm)	TABLE ANGLE (Degree)	REMARK
5775	95	95.68	/	/	34.93	9.89	45.5	100	340	Peak
5775	91.32	92	/	/	34.93	9.89	45.5	100	340	Average

REMARKS:

- Emission Level = Read Level+ Antenna Factor + Cable Loss- Preamp Factor
Margin value = Emission level – Limit value.
- 5775MHz: Fundamental frequency.



OBE DATA

802.11ac (80MHZ)

ANTENNA POLARITY & TEST DISTANCE: HORIZONTAL AT 3 M										
FREQ. (MHz)	EMISSION LEVEL (dBuV/m)	READ LEVEL (dBuV)	LIMIT (dBuV/m)	MARGIN (dB)	ANTENNA FACTOR (dB /m)	CABLE LOSS (dB)	PREAMP FACTOR (dB)	ANTENNA HEIGHT (cm)	TABLE ANGLE (Degree)	REMARK
5640.725	58.22	58.9	68.2	-9.98	34.97	9.85	45.5	100	0	Peak
5979.875	57.09	57.25	68.2	-11.11	35.38	9.96	45.5	100	0	Peak
ANTENNA POLARITY & TEST DISTANCE: VERTICAL AT 3 M										
FREQ. (MHz)	EMISSION LEVEL (dBuV/m)	READ LEVEL (dBuV)	LIMIT (dBuV/m)	MARGIN (dB)	ANTENNA FACTOR (dB /m)	CABLE LOSS (dB)	PREAMP FACTOR (dB)	ANTENNA HEIGHT (cm)	TABLE ANGLE (Degree)	REMARK
5627.425	56.28	57.19	68.2	-11.92	34.75	9.84	45.5	100	360	Peak
5964.675	57.05	57.43	68.2	-11.15	35.16	9.96	45.5	100	360	Peak

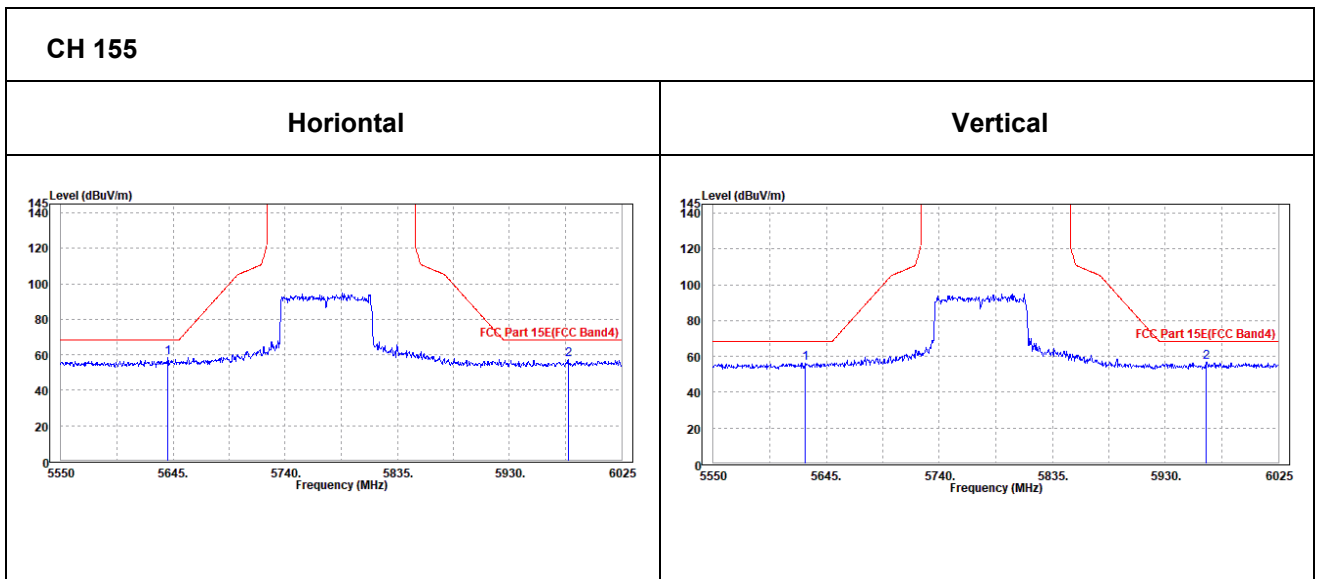



802.11ac (20MHZ)

Worst case harmonic:

CHANNEL	TX Channel 157	DETECTOR FUNCTION	Peak (PK)
FREQUENCY RANGE	1GHz ~ 40GHz		Average (AV)

ANTENNA POLARITY & TEST DISTANCE: HORIZONTAL AT 3 M

	Freq	Level	Read Level	Limit Line	Over Limit	Factor	Remark	Pol/Phase
	MHz	dBuV/m	dBuV	dBuV/m	dB	dB/m		
1	11570.000	54.33	45.05	74.00	-19.67	9.28	Peak	Horizontal
2	11570.000	45.82	36.54	54.00	-8.18	9.28	Average	Horizontal
3	PK17354.000	60.67	42.37	74.00	-13.33	18.30	Peak	Horizontal
4	PP17354.000	50.57	32.27	54.00	-3.43	18.30	Average	Horizontal

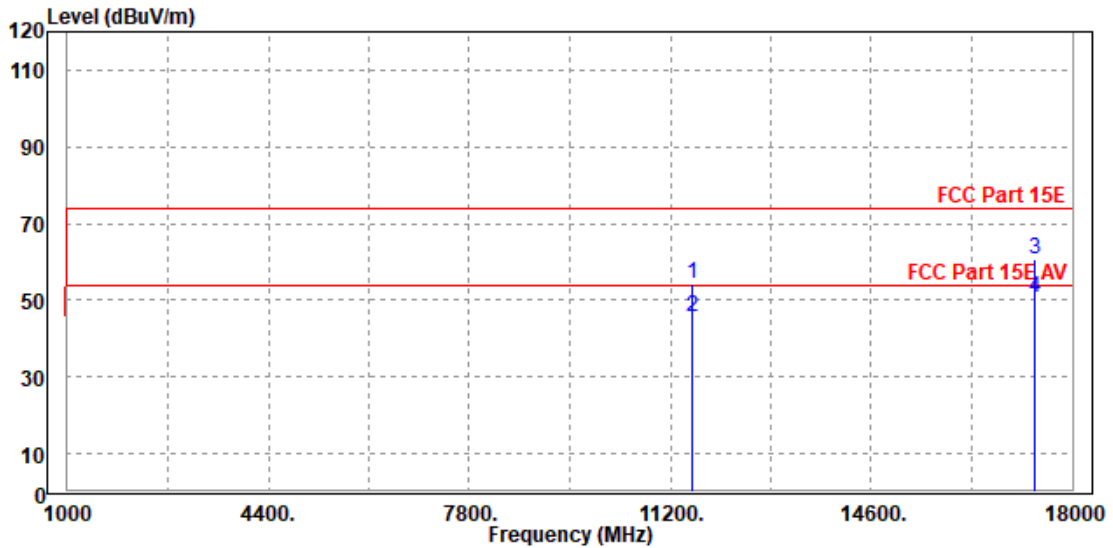



ANTENNA POLARITY & TEST DISTANCE: VERTICAL AT 3 M

	Freq	Level	Read Level	Limit Line	Over Limit	Factor	Remark	Pol/Phase
	MHz	dBuV/m	dBuV	dBuV/m	dB	dB/m		
1	11574.000	53.48	43.68	74.00	-20.52	9.80	Peak	Vertical
2	11574.000	44.09	34.29	54.00	-9.91	9.80	Average	Vertical
3	PK17355.000	60.02	42.95	74.00	-13.98	17.07	Peak	Vertical
4	PP17355.000	50.59	33.52	54.00	-3.41	17.07	Average	Vertical

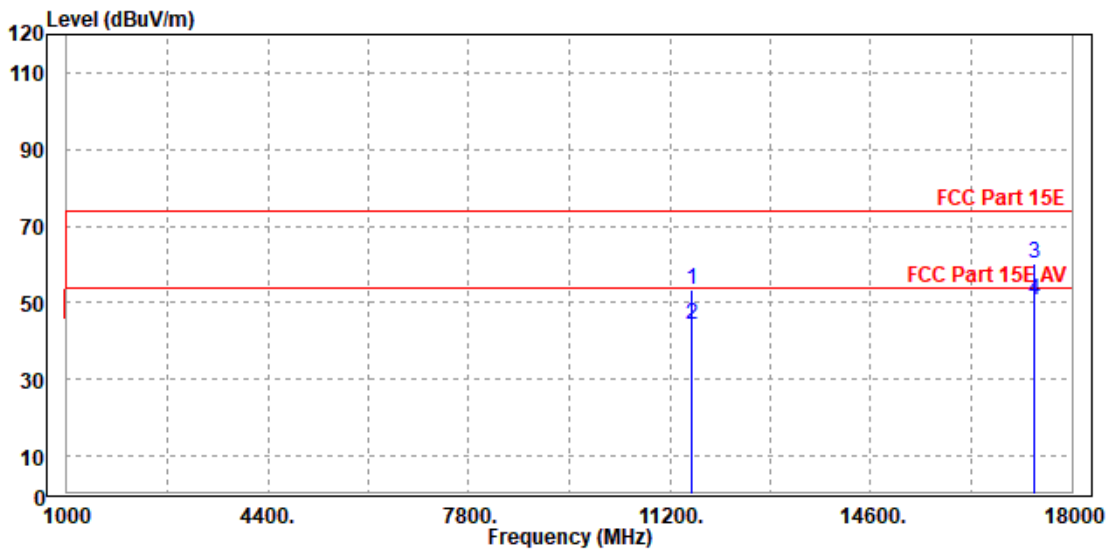

REMARKS:

1. Emission Level = Read Level+ Antenna Factor + Cable Loss- Preamp Factor
Margin value = Emission level – Limit value.
2. 5785MHz: Fundamental frequency.
3. For frequency above 18GHz, the emission was tested 20db below the limit so the data not recorded in the sheet.



3.2 CONDUCTED EMISSION MEASUREMENT

3.2.1 LIMITS OF CONDUCTED EMISSION MEASUREMENT

FREQUENCY OF EMISSION (MHz)	CONDUCTED LIMIT (dBµV)	
	Quasi-peak	Average
0.15 ~ 0.5	66 to 56	56 to 46
0.5 ~ 5	56	46
5 ~ 30	60	50

- NOTE:**
1. The lower limit shall apply at the transition frequencies.
 2. The limit decreases in line with the logarithm of the frequency in the range of 0.15 to 0.50MHz.
 3. All emanations from a class A/B digital device or system, including any network of conductors and apparatus connected thereto, shall not exceed the level of field strengths specified above.

3.2.2 TEST INSTRUMENTS

Equipment	Manufacturer	Model No.	Serial No.	Last Cal.	Next Cal.
EMI Test Receiver	Rohde&Schwarz	ESR3	101900	Feb. 14,23	Feb. 13,24
EMC32 test software	Rohde&Schwarz	EMC32	NA	NA	NA
LISN network	Rohde&Schwarz	ENV216	101922	Mar. 10,23	Mar. 09,24

- NOTE:**
1. The test was performed in CE shielded room.
 2. The calibration interval of the above test instruments is 12 months. And the calibrations are traceable to CEPREI/CHINA, GRGT/CHINA and NIM/CHINA.

3.2.3 TEST PROCEDURES

- a. The EUT was placed 0.4 meters from the conducting wall of the shielded room with EUT being connected to the power mains through a line impedance stabilization network (LISN). Other support units were connected to the power mains through another LISN. The two LISNs provide 50 ohm/ 50uH of coupling impedance for the measuring instrument.
- b. Both lines of the power mains connected to the EUT were checked for maximum conducted interference.
- c. The frequency range from 150kHz to 30MHz was searched. Emission levels under (Limit - 20dB) was not recorded.

NOTE: All modes of operation were investigated and the worst-case emissions are reported.



3.2.4 DEVIATION FROM TEST STANDARD

No deviation.

3.2.5 TEST SETUP

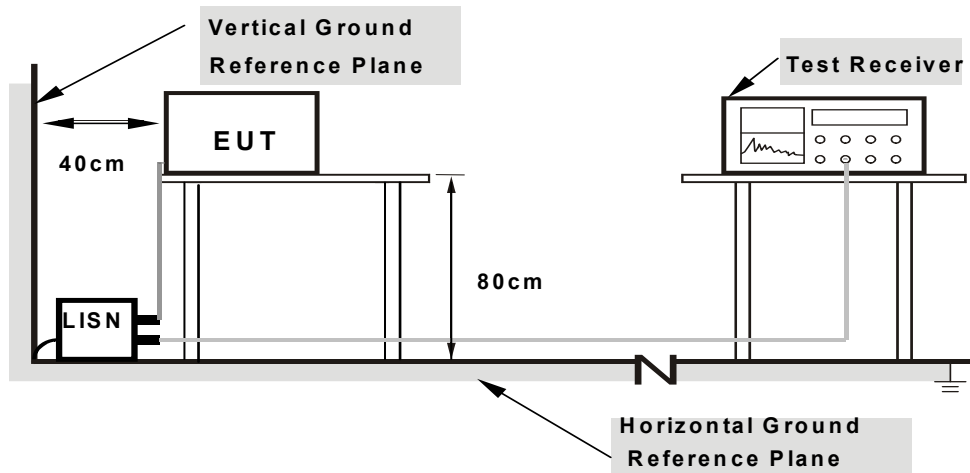

- Note:**
- 1.Support units were connected to second LISN.
 - 2.Both of LISNs (AMN) are 80 cm from EUT and at least 80 cm from other units and other metal planes

For the actual test configuration, please refer to the attached file (Test Setup Photo).

3.2.6 EUT OPERATING CONDITIONS

Same as 3.1.7.



3.2.7 TEST RESULTS

CONDUCTED WORST-CASE DATA:

Frequency Range	150KHz ~ 30MHz	Detector Function & Resolution Bandwidth	Quasi-Peak (QP) / Average (AV), 9 kHz
Input Power	120Vac, 60Hz	Environmental Conditions	26deg. C, 51%RH
Tested By	Carl Xie		

Frequency (MHz)	QuasiPeak (dBuV)	CAverage (dBuV)	Limit (dBuV)	Margin (dB)	Line	Filter	Corr. (dB)
0.150000	---	23.56	56.00	32.44	L1	ON	9.7
0.150000	45.24	---	66.00	20.76	L1	ON	9.7
0.168000	---	21.26	55.06	33.80	L1	ON	9.7
0.168000	42.34	---	65.06	22.72	L1	ON	9.7
0.464000	---	14.03	46.62	32.59	L1	ON	9.7
0.464000	28.59	---	56.62	28.03	L1	ON	9.7
0.788000	---	9.06	46.00	36.94	L1	ON	9.7
0.788000	19.83	---	56.00	36.17	L1	ON	9.7
1.344000	---	7.51	46.00	38.49	L1	ON	9.7
1.344000	17.33	---	56.00	38.67	L1	ON	9.7
21.248000	---	15.79	50.00	34.21	L1	ON	9.8
21.248000	24.32	---	60.00	35.68	L1	ON	9.8

- REMARKS:**
1. Q.P. and AV. are abbreviations of quasi-peak and average individually.
 2. "-": The Quasi-peak reading value also meets average limit and measurement with the average detector is unnecessary.
 3. The emission levels of other frequencies were very low against the limit.
 4. Margin value = Limit value - Emission level
 5. Correction factor = Insertion loss + Cable loss
 6. Emission Level = Correction Factor + Reading Value.

Full Spectrum

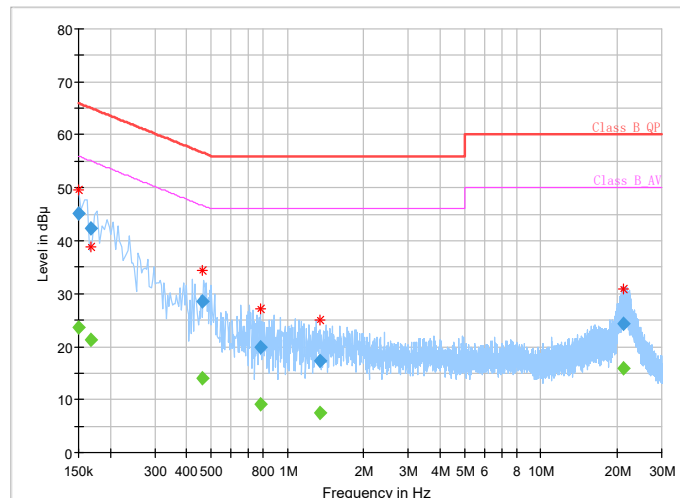



Frequency Range	150KHz ~ 30MHz	Detector Function & Resolution Bandwidth	Quasi-Peak (QP) / Average (AV), 9 kHz
Input Power	120Vac, 60Hz	Environmental Conditions	26deg. C, 51%RH
Tested By	Carl Xie		

Frequency (MHz)	QuasiPeak (dBuV)	CAverage (dBuV)	Limit (dBuV)	Margin (dB)	Line	Filter	Corr. (dB)
0.150000	---	25.61	56.00	30.39	N	ON	9.7
0.150000	45.15	---	66.00	20.85	N	ON	9.7
0.172000	---	23.24	54.86	31.62	N	ON	9.7
0.172000	42.35	---	64.86	22.51	N	ON	9.7
0.460000	---	20.48	46.69	26.21	N	ON	9.7
0.460000	33.15	---	56.69	23.54	N	ON	9.7
0.784000	---	13.37	46.00	32.63	N	ON	9.7
0.784000	23.72	---	56.00	32.28	N	ON	9.7
1.604000	---	10.92	46.00	35.08	N	ON	9.8
1.604000	22.52	---	56.00	33.48	N	ON	9.8
22.072000	---	15.49	50.00	34.51	N	ON	9.9
22.072000	24.27	---	60.00	35.73	N	ON	9.9

- REMARKS:**
1. Q.P. and AV. are abbreviations of quasi-peak and average individually.
 2. "-": The Quasi-peak reading value also meets average limit and measurement with the average detector is unnecessary.
 3. The emission levels of other frequencies were very low against the limit.
 4. Margin value = Limit value - Emission level
 5. Correction factor = Insertion loss + Cable loss
 6. Emission Level = Correction Factor + Reading Value.

Full Spectrum

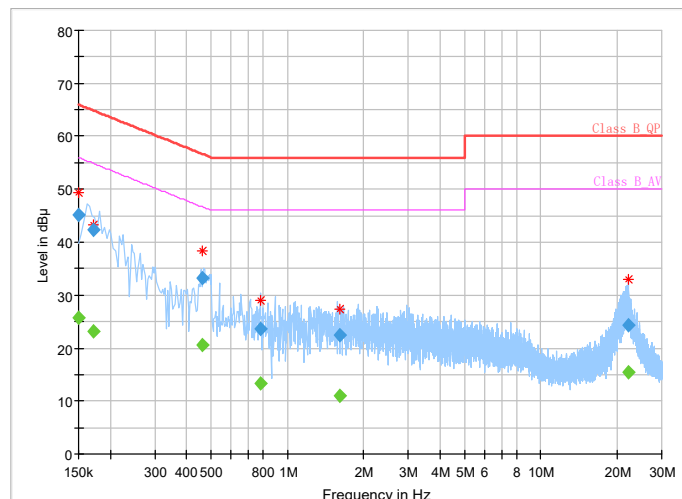



3.3 MAXIMUM CONDUCTED OUTPUT POWER MEASUREMENT

3.3.1 LIMITS OF MAXIMUM CONDUCTED OUTPUT POWER MEASUREMENT

Operation Band	EUT Category		LIMIT
U-NII-1		Outdoor Access Point	1 Watt (30 dBm) (Max. e.i.r.p ≤ 125mW(21 dBm) at any elevation angle above 30 degrees as measured from the horizon)
		Fixed point-to-point Access Point	1 Watt (30 dBm)
		Indoor Access Point	1 Watt (30 dBm)
	√	Client devices	250mW (24 dBm)
U-NII-2A	√		250mW (24 dBm) or 11 dBm+10 log B*
U-NII-2C	√		250mW (24 dBm) or 11 dBm+10 log B*
U-NII-3	√		1 Watt (30 dBm)

NOTE: Where B is the 26dB emission bandwidth in MHz.



3.3.2 TEST SETUP

FOR POWER OUTPUT MEASUREMENT

802.11a, 802.11n/ac (20MHz), 802.11 n/ac (40MHz) TEST CONFIGURATION

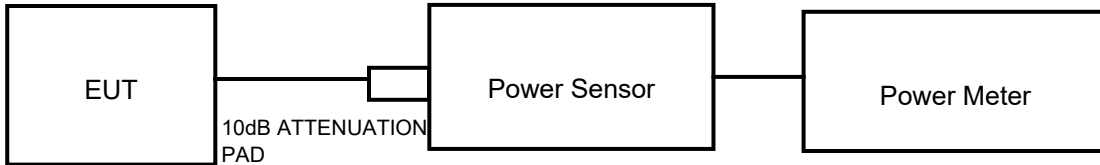

11ac (80MHz) TEST CONFIGURATION

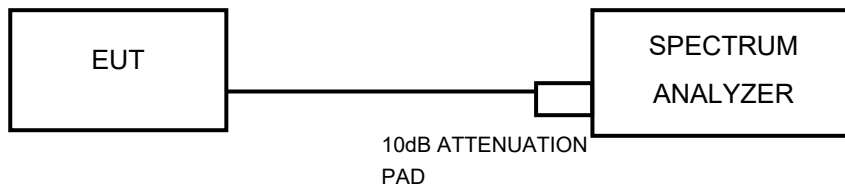

FOR 26dB BANDWIDTH

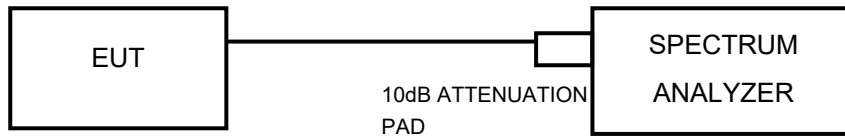

3.3.3 TEST INSTRUMENTS

Equipment	Manufacturer	Model No.	Serial No.	Last Cal.	Next Cal.
Power Meter	ANRITSU	ML2495A	1506002	Feb. 14,23	Feb. 13,24
EXA Signal Analyzer	KEYSIGHT	N9010A-526	MY54510523	Feb. 14,23	Feb. 13,24
EXA Signal Analyzer	KEYSIGHT	N9010A-544	MY54510355	May.14,22	May.13,23
EXA Signal Analyzer	KEYSIGHT	N9010A-544	MY54510355	May.13,23	May.12,24
Power Sensor	ANRITSU	MA2411B	1339352	Feb. 14,23	Feb. 13,24

NOTE:

1. The calibration interval of the above test instruments is 12 months and the calibrations are traceable to CEPREI/CHINA, GRGT/CHINA and NIM/CHINA.
2. The test was performed in RF Oven room.



3.3.4 TEST PROCEDURE

FOR POWER MEASUREMENT

For 802.11a, 802.11 n/ac (20MHz), 802.11 n/ac (40MHz)

Method PM is used to perform output power measurement, trigger and gating function of wide band power meter is enabled to measure max output power of TX on burst. Duty factor is not added to measured value.

For 802.11ac (80MHz)

1. Measure the duty cycle, x , of the transmitter output signal as described in II.B.
2. Set span to encompass the EBW (or, alternatively, the entire 99% occupied bandwidth) of the signal.
3. Set RBW = 1 MHz.
4. Set VBW \geq 3 MHz.
5. Number of points in sweep $\geq 2 \times \text{span} / \text{RBW}$. (This ensures that bin-to-bin spacing is $\leq \text{RBW}/2$, so that narrowband signals are not lost between frequency bins.)
6. Sweep time = auto.
7. Detector = power averaging (rms), if available. Otherwise, use sample detector mode.
8. Do not use sweep triggering. Allow the sweep to “free run.”
9. Trace average at least 100 traces in power averaging (rms) mode; however, the number of traces to be averaged shall be increased above 100 as needed to ensure that the average accurately represents the true average over the on and off periods of the transmitter.
10. Add $10 \log (1/x)$, where x is the duty cycle, to the measured power to compute the average power during the actual transmission times (because the measurement represents an average over both the on and off times of the transmission). For example, add $10 \log (1/0.25) = 6 \text{ dB}$ if the duty cycle is 25%.



FOR 99 PERCENT OCCUPIED BANDWIDTH

The following procedure shall be used for measuring (99 %) power bandwidth:

1. Set center frequency to the nominal EUT channel center frequency.
2. Set span = 1.5 times to 5.0 times the OBW.
3. Set RBW = 1 % to 5 % of the OBW
4. Set VBW $\geq 3 \cdot$ RBW
5. Video averaging is not permitted. Where practical, a sample detection and single sweep mode shall be used. Otherwise, peak detection and max hold mode (until the trace stabilizes) shall be used.
6. Use the 99 % power bandwidth function of the instrument (if available).
7. If the instrument does not have a 99 % power bandwidth function, the trace data points are recovered and directly summed in power units. The recovered amplitude data points, beginning at the lowest frequency, are placed in a running sum until 0.5 % of the total is reached; that frequency is recorded as the lower frequency. The process is repeated until 99.5 % of the total is reached; that frequency is recorded as the upper frequency. The 99% occupied bandwidth is the difference between these two frequencies.

FOR 26dB BANDWIDTH

- 1) Set RBW = approximately 1% of the emission bandwidth.
- 2) Set the VBW > RBW.
- 3) Detector = Peak.
- 4) Trace mode = max hold.
- 5) Measure the maximum width of the emission that is 26 dB down from the peak of the emission. Compare this with the RBW setting of the analyzer. Readjust RBW and repeat measurement as needed until the RBW/EBW ratio is approximately 1%.

FOR 6dB BANDWIDTH

1. Set RBW = 100 kHz.
2. Set the video bandwidth (VBW) ≥ 3 RBW.
3. Detector = Peak.
4. Trace mode = max hold.
5. Sweep = auto couple.
6. Allow the trace to stabilize.
7. Measure the maximum width of the emission that is constrained by the frequencies associated with the two outermost amplitude points (upper and lower frequencies) that are attenuated by 6 dB relative to the maximum level measured in the fundamental emission.



3.3.5 DEVIATION FROM TEST STANDARD

No deviation.

3.3.6 EUT OPERATING CONDITIONS

The software provided by client to enable the EUT under transmission condition continuously at specific channel frequencies individually.



BUREAU Test Report No.: W7L-P23050004-1RF03
VERITAS

3.3.7 TEST RESULTS

Please Refer to Appendix A Of this test report.



3.4 MAXIMUM POWER SPECTRAL DENSITY MEASUREMENT

3.4.1 LIMITS OF MAXIMUM POWER SPECTRAL DENSITY MEASUREMENT

Operation Band	EUT Category		LIMIT
U-NII-1		Outdoor Access Point	17dBm/ MHz
		Fixed point-to-point Access Point	
		Indoor Access Point	
	√	Client devices	11dBm/ MHz
U-NII-2A	√		11dBm/ MHz
U-NII-2C	√		11dBm/ MHz
U-NII-3	√		30dBm/ 500kHz

3.4.2 TEST SETUP

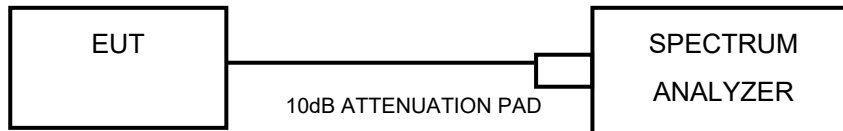

3.4.3 TEST INSTRUMENTS

Refer to section 3.3.3 to get information of above instrument.



3.4.4 TEST PROCEDURES

Using method SA-2

- 1) Set span to encompass the entire emission bandwidth (EBW) of the signal.
- 2) Set RBW = 1 MHz, Set VBW \geq 3 MHz, Detector = RMS
- 3) Set Channel power measure = 1MHz
- 4) Sweep time = auto, trigger set to "free run".
- 5) Trace average at least 100 traces in power averaging mode.
- 6) Add $10 \log(1/x)$, where x is the duty cycle, to the measured power in order to compute the average power during the actual transmission times (because the measurement represents an average over both the on and off times of the transmission).
- 7) Record the max value

3.4.5 DEVIATION FROM TEST STANDARD

No deviation.

3.4.6 EUT OPERATING CONDITIONS

Same as 3.1.7.



BUREAU Test Report No.: W7L-P23050004-1RF03
VERITAS

3.4.7 TEST RESULTS

Please Refer to Appendix A Of this test report.



3.5 AUTOMATICALLY DISCONTINUE TRANSMISSION

3.5.1 LIMIT OF AUTOMATICALLY DISCONTINUE TRANSMISSION

The device shall automatically discontinue transmission in case of either absence of information to transmit or operational failure. These provisions are not intended to preclude the transmission of control or signalling information or the use of repetitive codes used by certain digital technologies to complete frame or burst intervals. Applicants shall include in their application for equipment authorization a description of how this requirement is met.

3.5.2 TEST INSTRUMENTS

Refer to section 3.3.3 to get information of above instrument.

3.5.3 TEST RESULT

While the EUT is not transmitting any information, the EUT can automatically discontinue transmission and become standby mode for power saving. The EUT can detect the controlling of ACK message transmitting from remote device and verify whether it shall resend or discontinue transmission



Test Report No.: W7L-P23050004-1RF03

4 PHOTOGRAPHS OF THE TEST CONFIGURATION

Please refer to the attached file (Test Setup Photo).



Test Report No.: W7L-P23050004-1RF03

5 MODIFICATIONS RECORDERS FOR ENGINEERING CHANGES TO THE EUT BY THE LAB

No modifications were made to the EUT by the lab during the test.



6 Appendix

EMISSION BANDWIDTH

TEST RESULT

TestMode	Antenna	Frequency[MHz]	26db EBW [MHz]	FL[MHz]	FH[MHz]	Limit[MHz]	Verdict
11A	Ant1	5180	24.200	5167.560	5191.760	---	---
		5200	26.240	5187.360	5213.600	---	---
		5240	26.360	5225.720	5252.080	---	---
		5260	23.040	5249.800	5272.840	---	---
		5300	24.080	5289.880	5313.960	---	---
		5320	24.520	5308.640	5333.160	---	---
		5500	24.960	5487.320	5512.280	---	---
		5580	23.280	5568.920	5592.200	---	---
		5700	24.760	5686.480	5711.240	---	---
		5745	26.640	5732.040	5758.680	---	---
		5785	25.680	5771.480	5797.160	---	---
		5825	25.600	5811.480	5837.080	---	---
11N20SISO	Ant1	5180	26.800	5167.760	5194.560	---	---
		5200	28.200	5185.560	5213.760	---	---
		5240	28.920	5226.000	5254.920	---	---
		5260	29.840	5245.560	5275.400	---	---
		5300	25.640	5287.880	5313.520	---	---
		5320	24.160	5309.040	5333.200	---	---
		5500	29.240	5487.040	5516.280	---	---
		5580	25.640	5568.520	5594.160	---	---
		5700	27.080	5686.480	5713.560	---	---
		5745	25.640	5732.280	5757.920	---	---
		5785	25.920	5770.640	5796.560	---	---
		5825	28.320	5812.000	5840.320	---	---
11N40SISO	Ant1	5190	44.720	5169.760	5214.480	---	---
		5230	40.640	5209.600	5250.240	---	---
		5270	39.840	5250.000	5289.840	---	---
		5310	44.240	5290.240	5334.480	---	---
		5510	46.080	5486.080	5532.160	---	---
		5550	39.760	5529.840	5569.600	---	---



		5670	48.080	5646.640	5694.720	---	---
		5755	48.400	5731.000	5779.400	---	---
		5795	48.800	5770.040	5818.840	---	---
11AC20SISO	Ant1	5180	29.280	5167.320	5196.600	---	---
		5200	28.840	5185.880	5214.720	---	---
		5240	25.200	5228.800	5254.000	---	---
		5260	28.640	5245.640	5274.280	---	---
		5300	27.440	5286.000	5313.440	---	---
		5320	26.680	5307.280	5333.960	---	---
		5500	28.840	5485.680	5514.520	---	---
		5580	28.040	5566.520	5594.560	---	---
		5700	24.480	5688.280	5712.760	---	---
		5745	29.640	5731.040	5760.680	---	---
		5785	25.520	5772.680	5798.200	---	---
		5825	25.360	5812.560	5837.920	---	---
11AC40SISO	Ant1	5190	50.240	5163.600	5213.840	---	---
		5230	39.760	5210.320	5250.080	---	---
		5270	45.440	5250.000	5295.440	---	---
		5310	40.320	5290.320	5330.640	---	---
		5510	42.880	5490.160	5533.040	---	---
		5550	46.880	5523.920	5570.800	---	---
		5670	43.600	5650.000	5693.600	---	---
		5755	44.240	5732.600	5776.840	---	---
		5795	46.080	5769.800	5815.880	---	---
11AC80SISO	Ant1	5210	89.280	5167.760	5257.040	---	---
		5290	96.000	5244.400	5340.400	---	---
		5530	98.400	5475.600	5574.000	---	---
		5610	101.120	5554.640	5655.760	---	---
		5775	95.040	5727.320	5822.360	---	---



TEST GRAPHS

11A_Ant1_5180

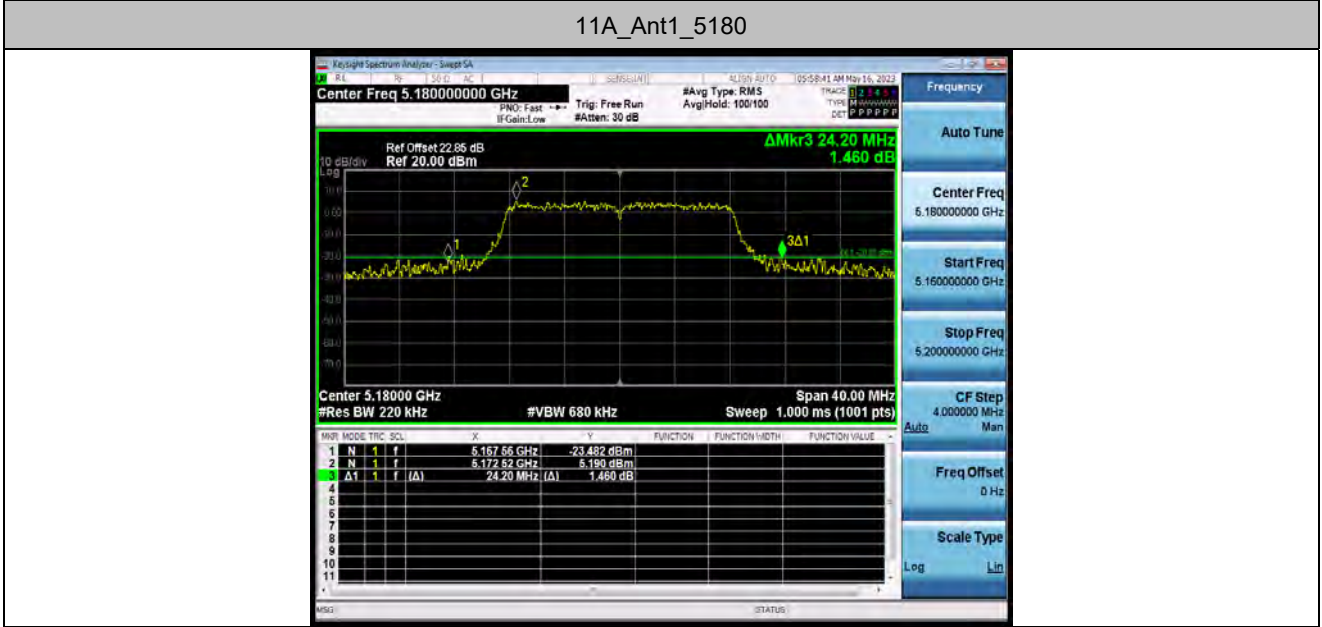

11A_Ant1_5200

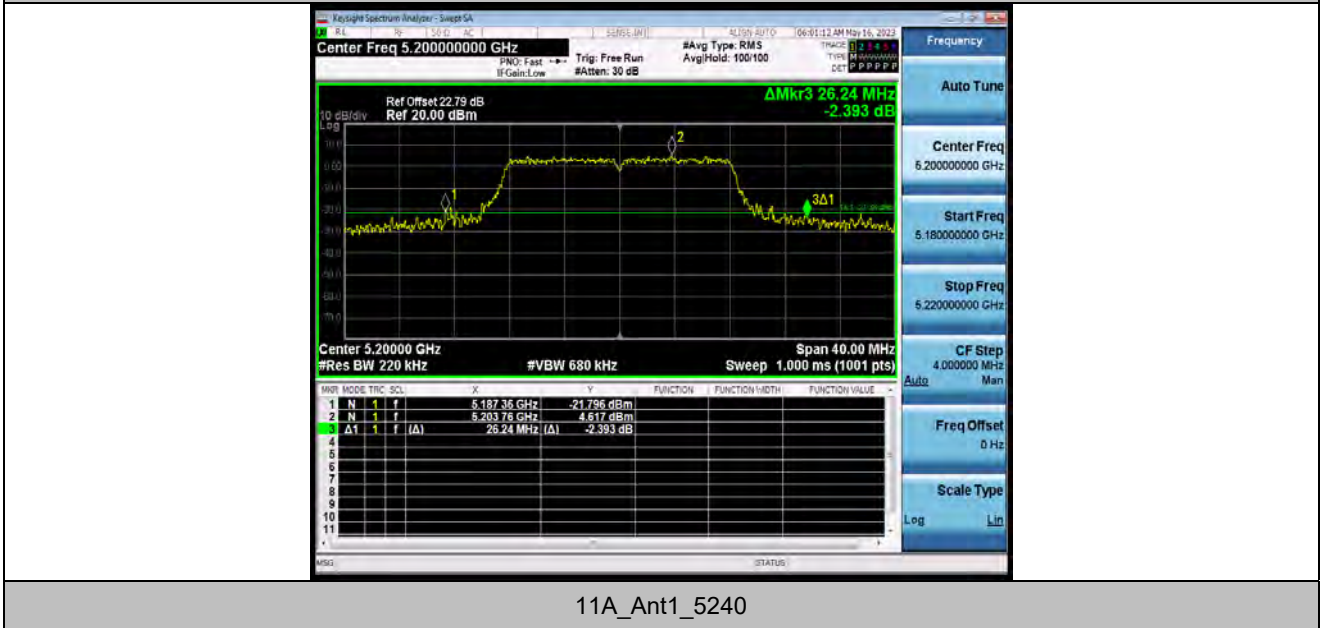

11A_Ant1_5240



BUREAU VERITAS

Test Report No.: W7L-P23050004-1RF03

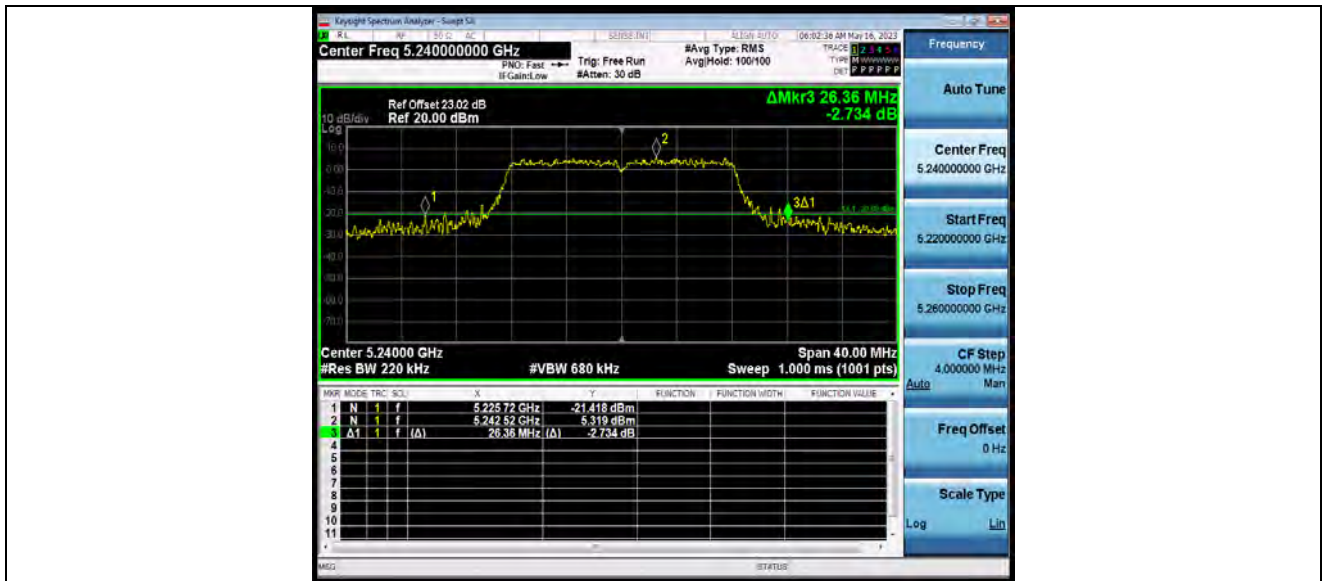

11A_Ant1_5260

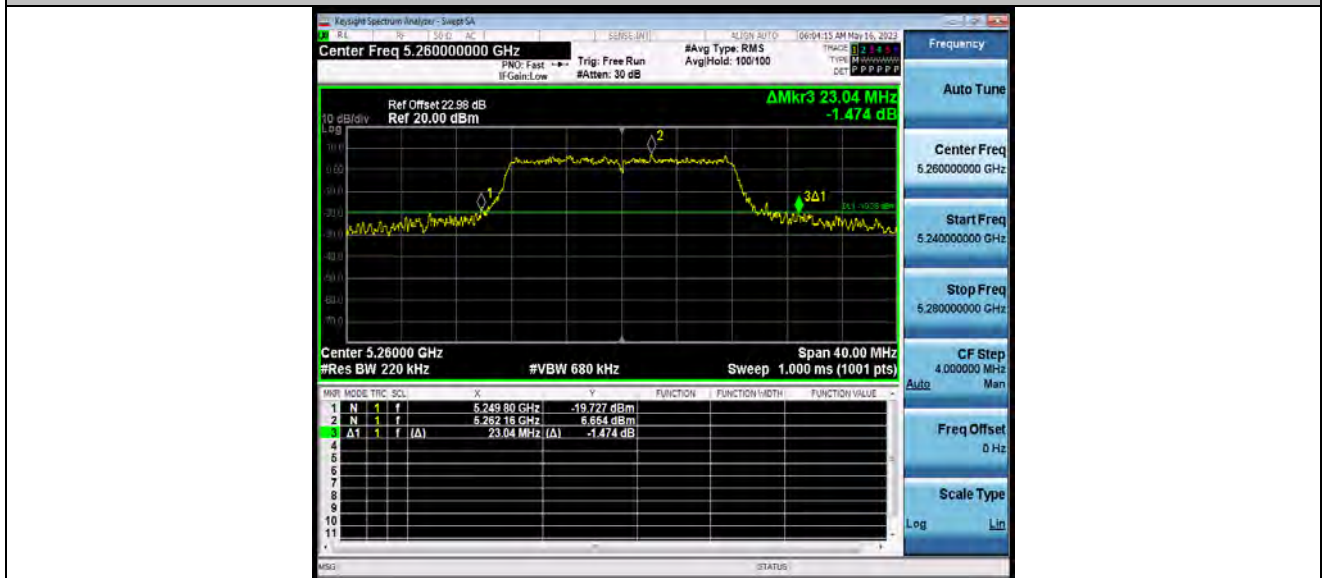

11A_Ant1_5300



BUREAU VERITAS

Test Report No.: W7L-P23050004-1RF03

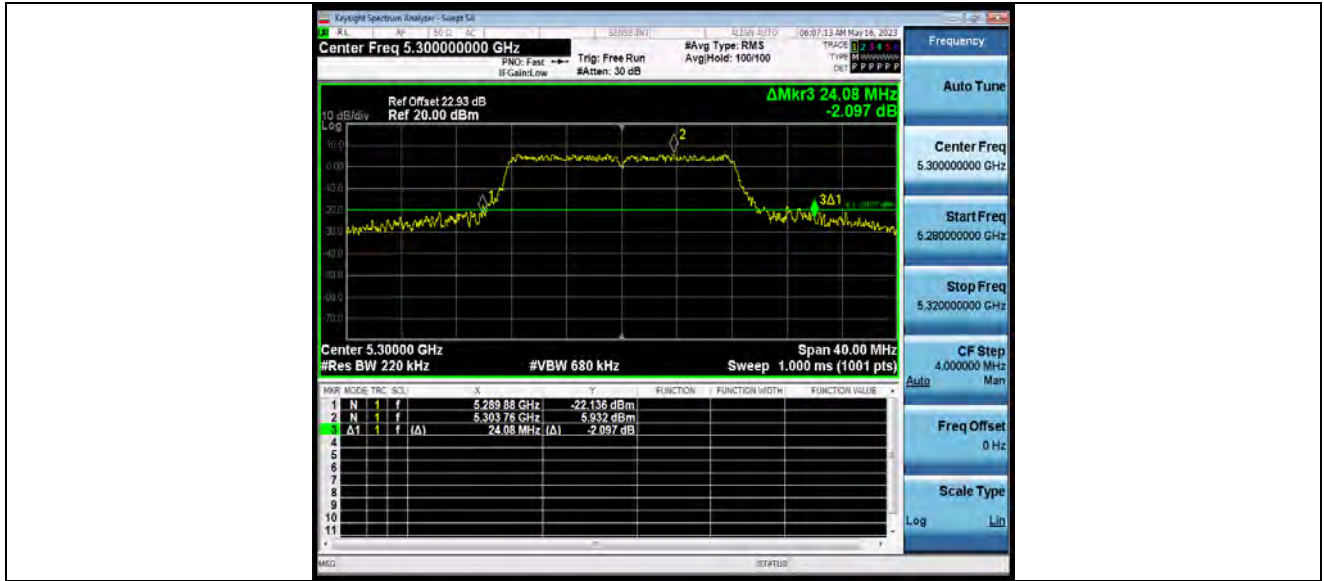

11A_Ant1_5320



11A_Ant1_5500



BUREAU VERITAS

Test Report No.: W7L-P23050004-1RF03

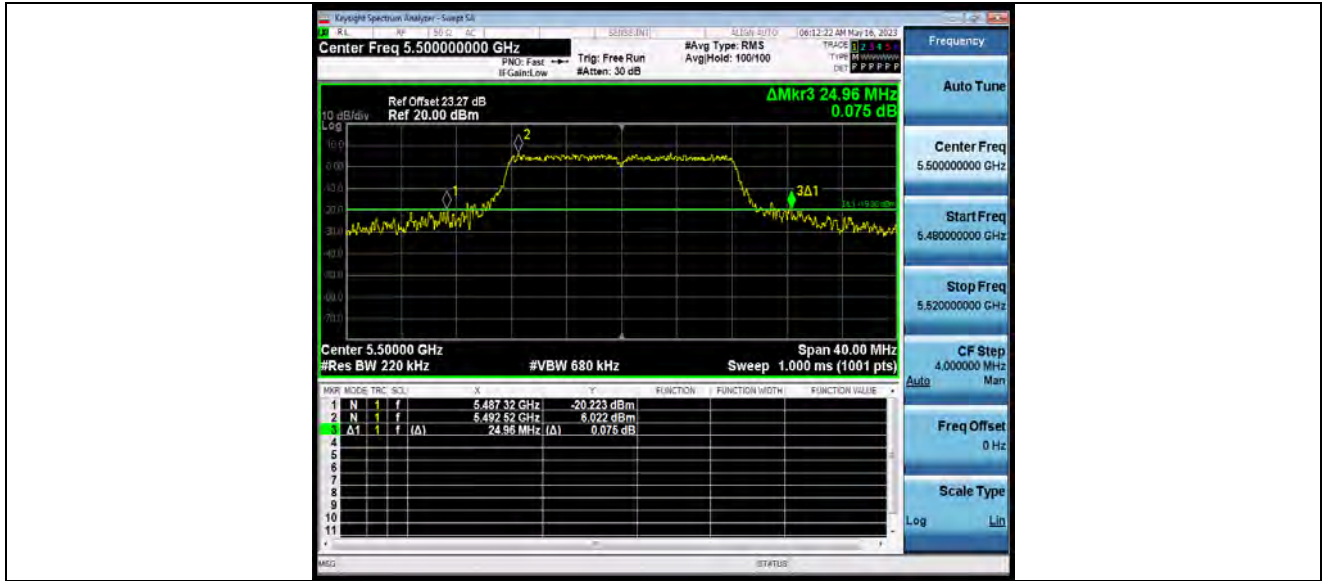

11A_Ant1_5580

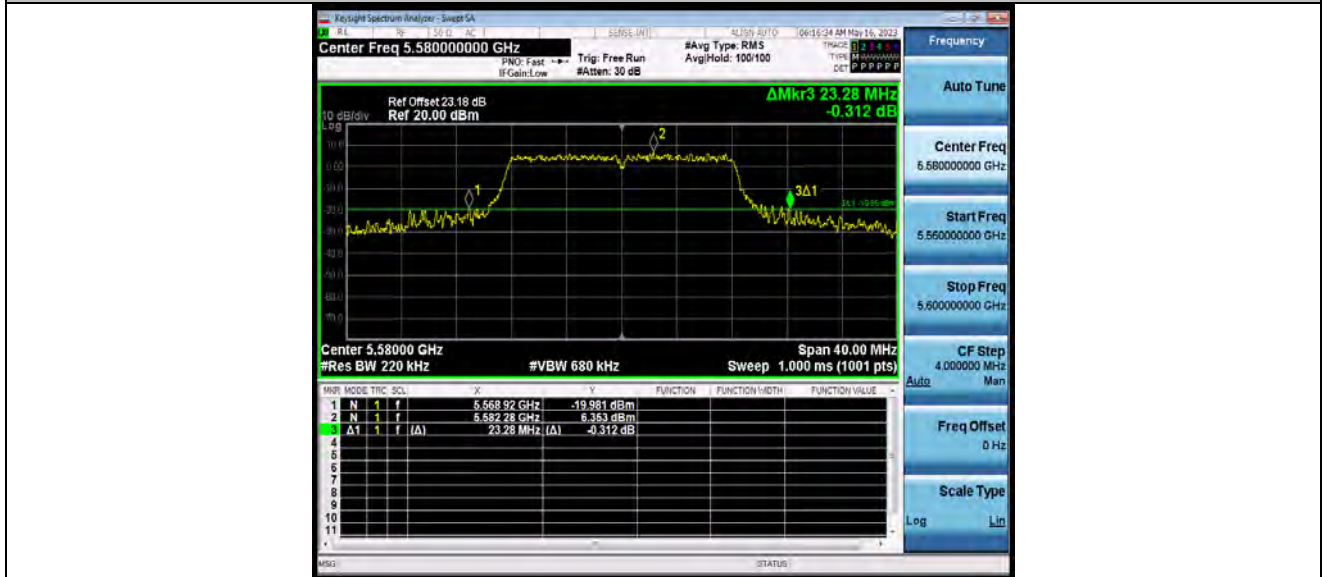

11A_Ant1_5700



BUREAU VERITAS

Test Report No.: W7L-P23050004-1RF03

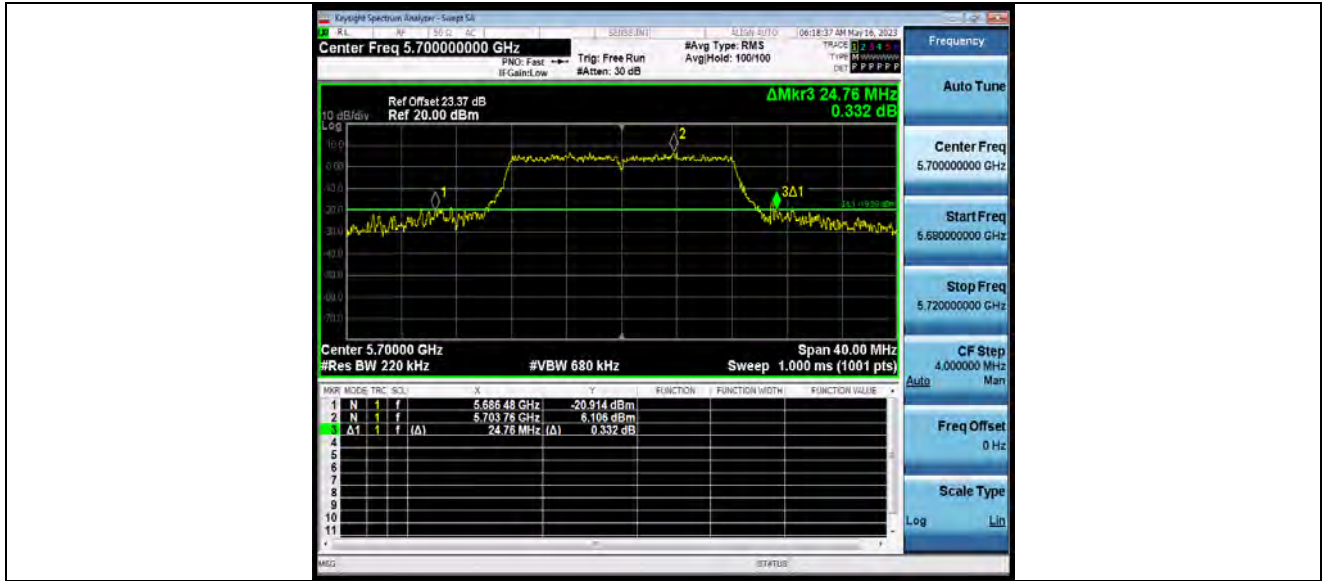

11A_Ant1_5745

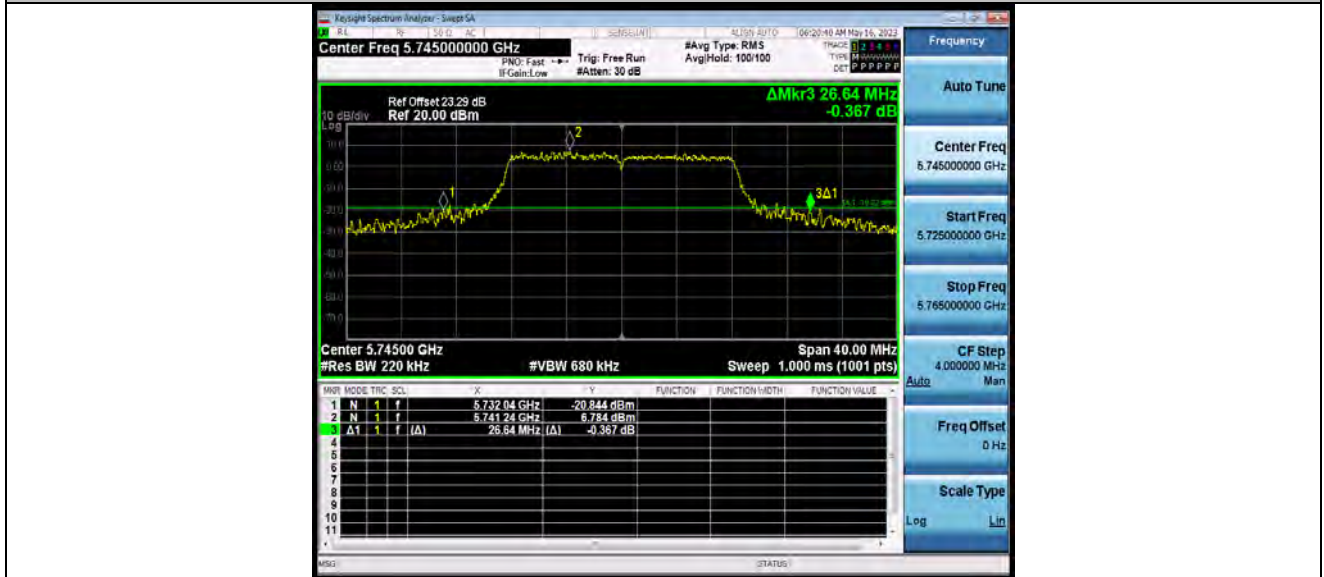

11A_Ant1_5785



BUREAU VERITAS

Test Report No.: W7L-P23050004-1RF03

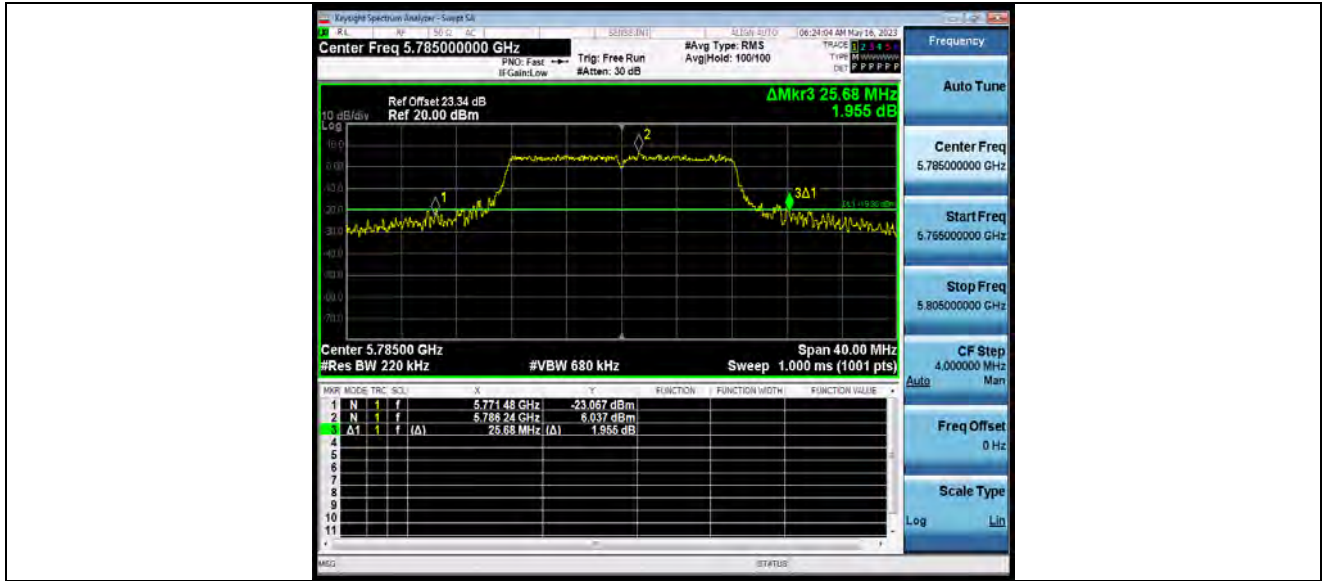

11A_Ant1_5825

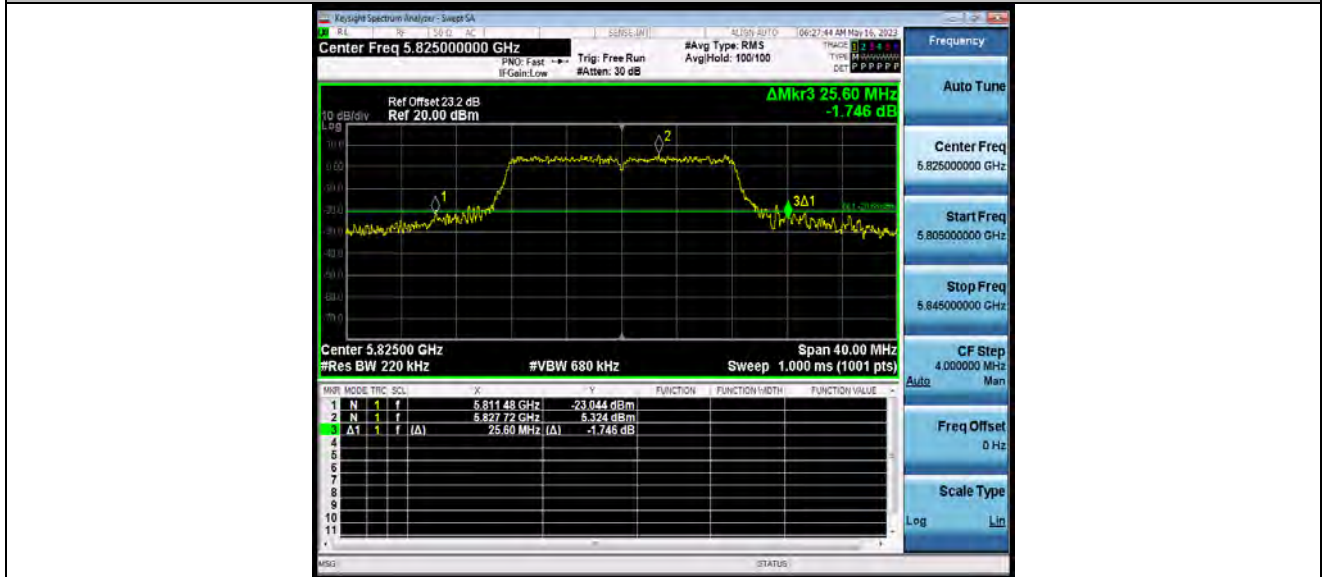

11N20SISO_Ant1_5180



BUREAU VERITAS

Test Report No.: W7L-P23050004-1RF03



11N20SISO_Ant1_5200

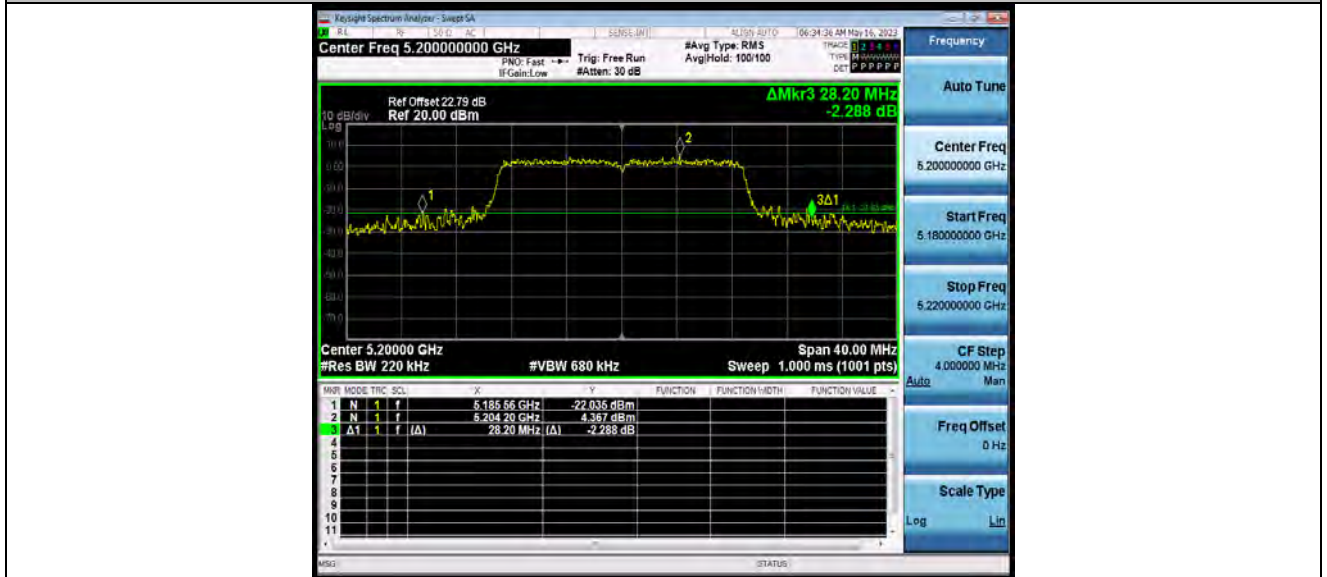

11N20SISO_Ant1_5240



**BUREAU
VERITAS**

Test Report No.: W7L-P23050004-1RF03



11N20SISO_Ant1_5260



11N20SISO_Ant1_5300



BUREAU VERITAS

Test Report No.: W7L-P23050004-1RF03



11N20SISO_Ant1_5320



11N20SISO_Ant1_5500



BUREAU VERITAS

Test Report No.: W7L-P23050004-1RF03



11N20SISO_Ant1_5580



11N20SISO_Ant1_5700



BUREAU VERITAS

Test Report No.: W7L-P23050004-1RF03



11N20SISO_Ant1_5745

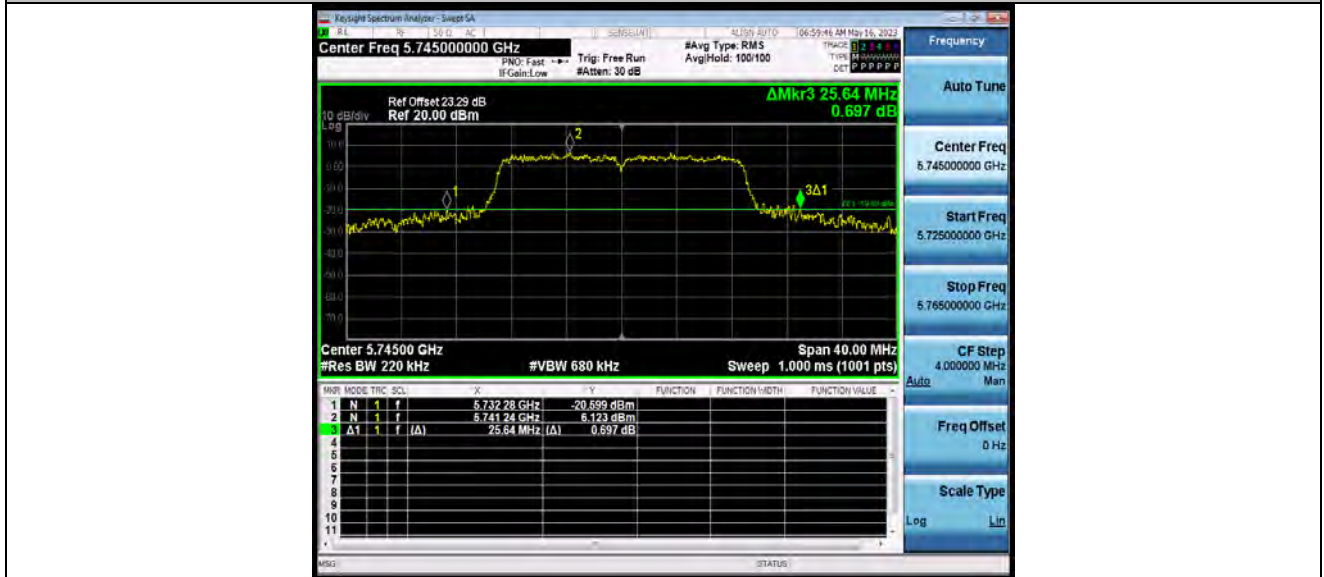

11N20SISO_Ant1_5785



BUREAU VERITAS

Test Report No.: W7L-P23050004-1RF03

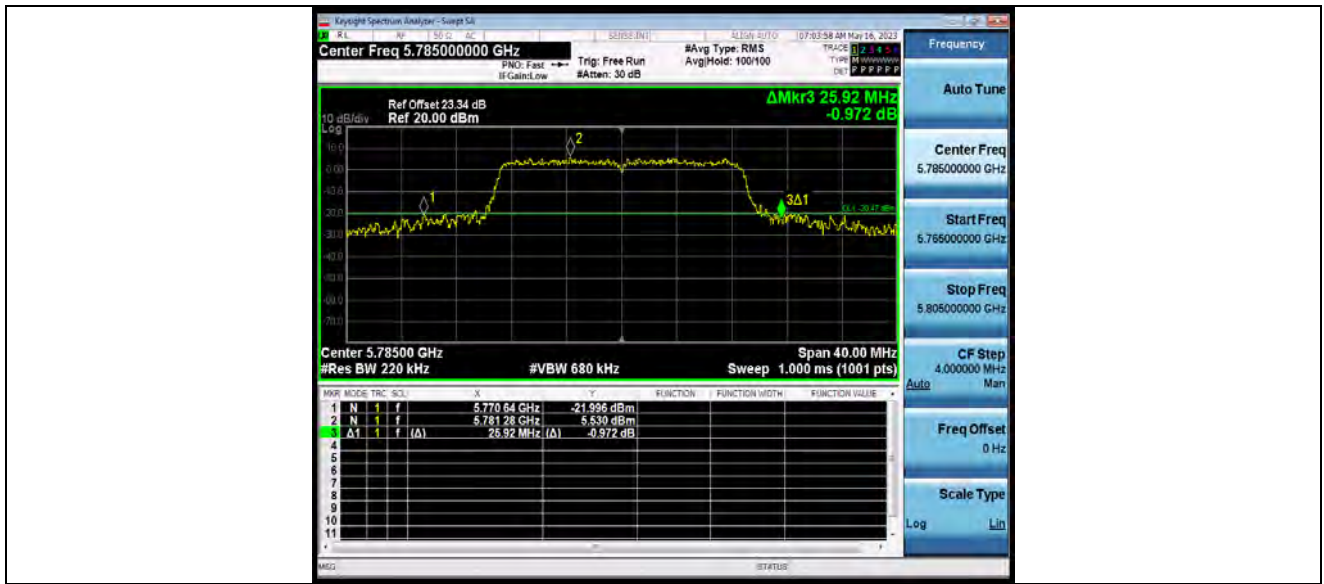

11N20SISO_Ant1_5825



11N40SISO_Ant1_5190



BUREAU VERITAS

Test Report No.: W7L-P23050004-1RF03



11N40SISO_Ant1_5230

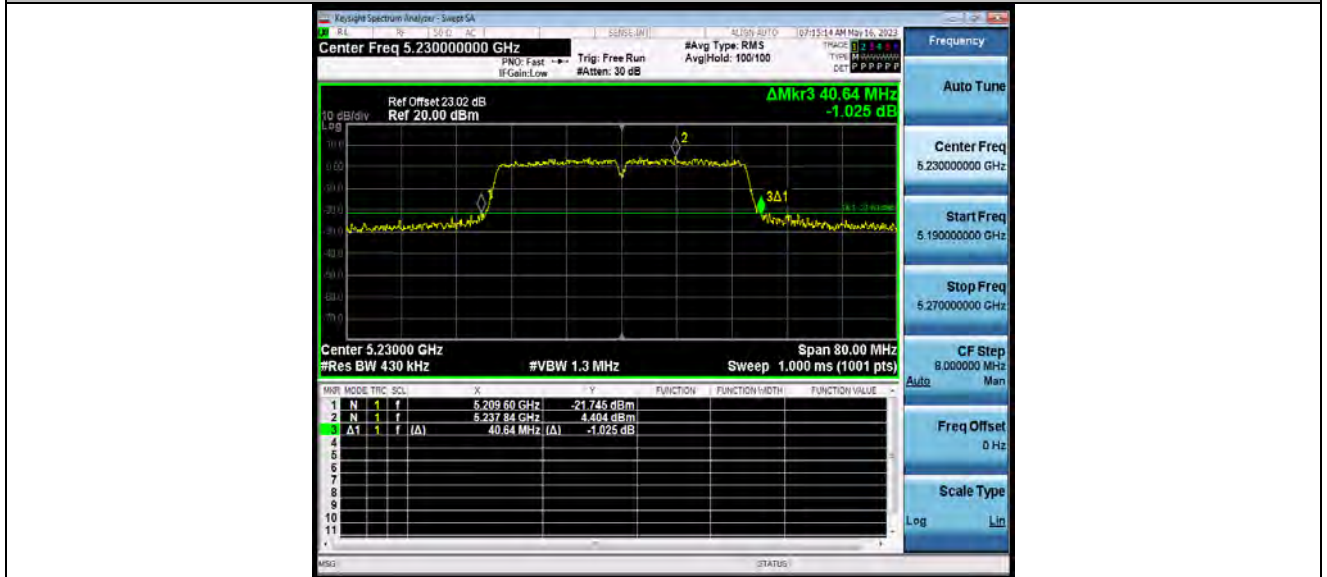

11N40SISO_Ant1_5270



**BUREAU
VERITAS**

Test Report No.: W7L-P23050004-1RF03



11N40SISO_Ant1_5310

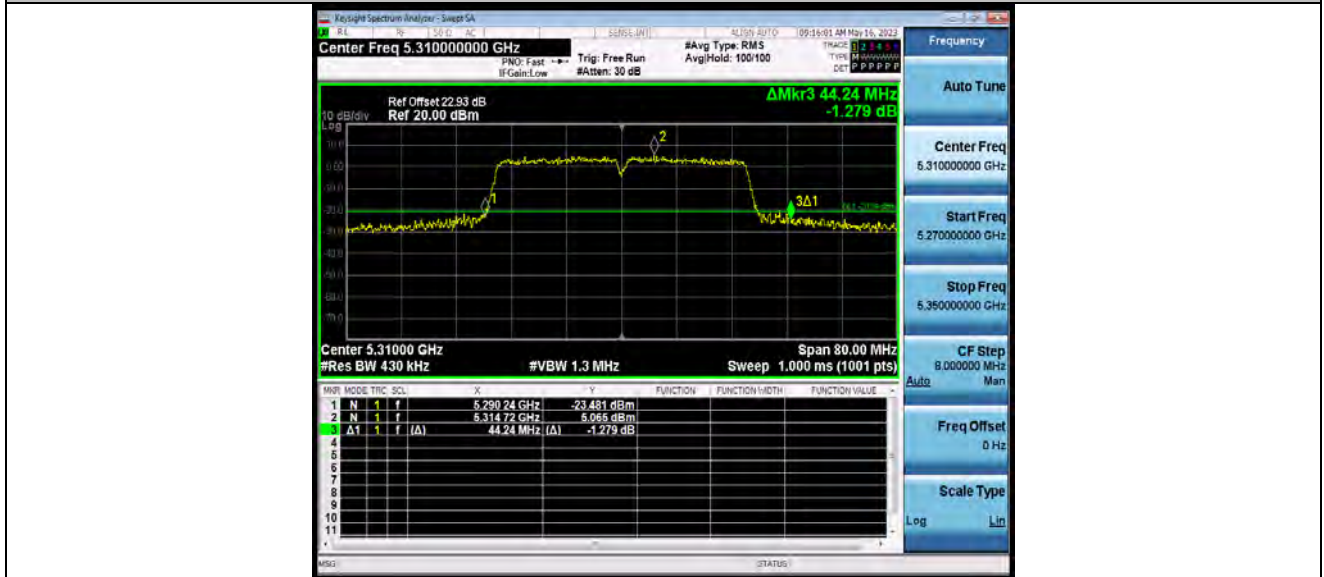

11N40SISO_Ant1_5510



BUREAU VERITAS

Test Report No.: W7L-P23050004-1RF03



11N40SISO_Ant1_5550

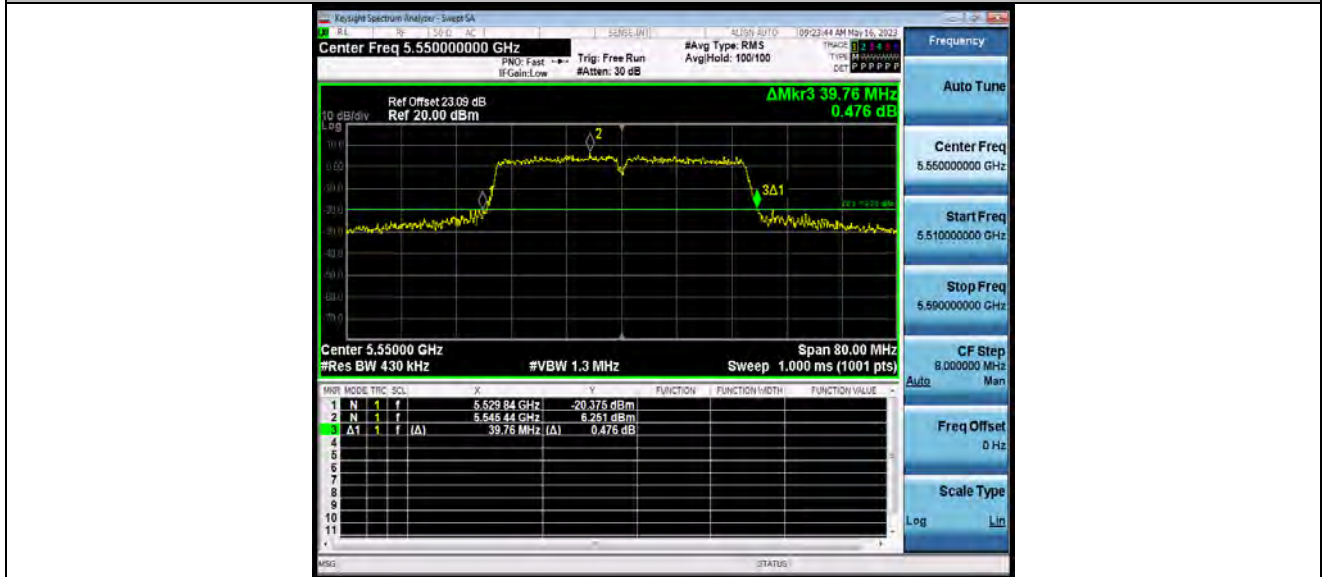

11N40SISO_Ant1_5670



BUREAU VERITAS

Test Report No.: W7L-P23050004-1RF03

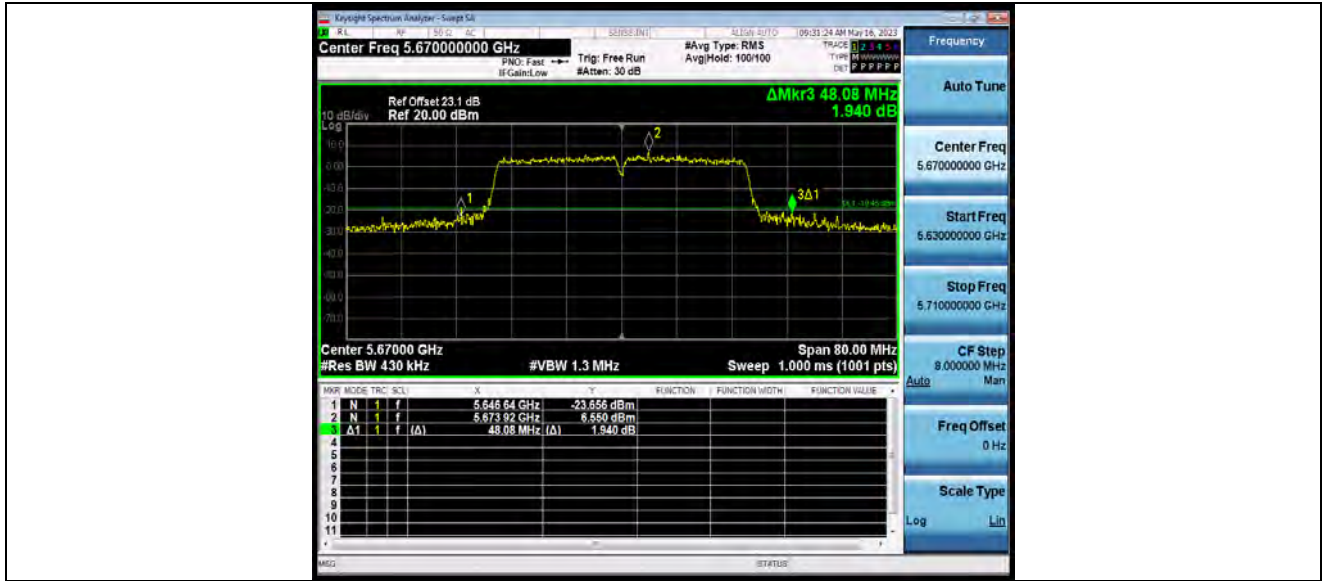

11N40SISO_Ant1_5755

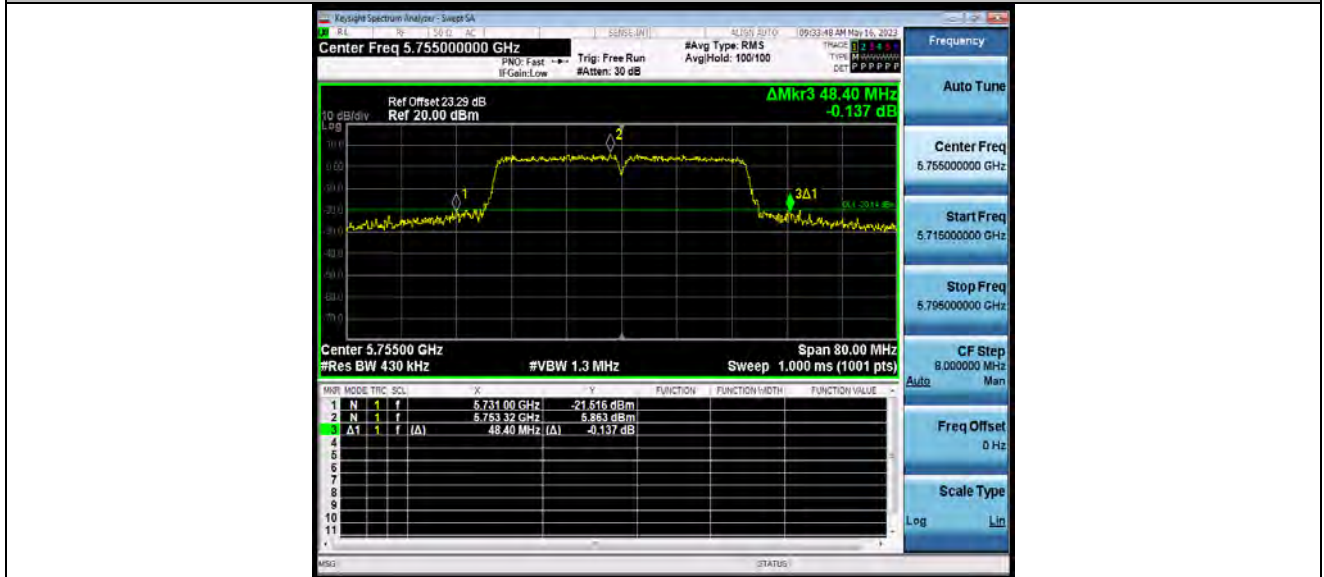

11N40SISO_Ant1_5795



BUREAU VERITAS

Test Report No.: W7L-P23050004-1RF03

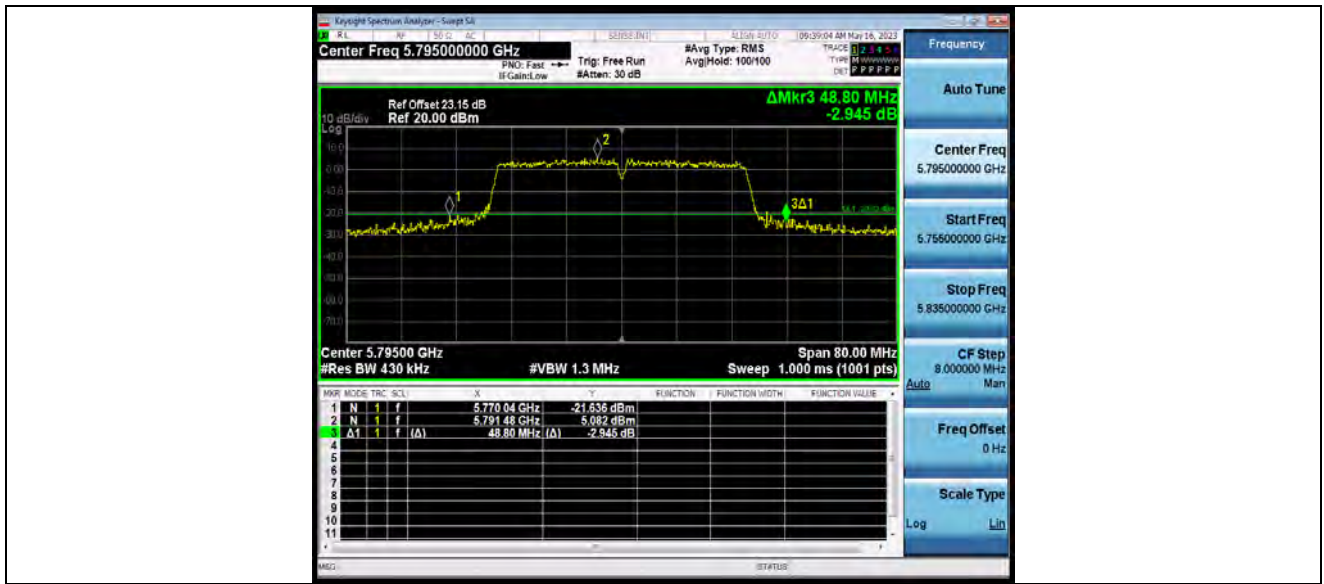

11AC20SISO_Ant1_5180

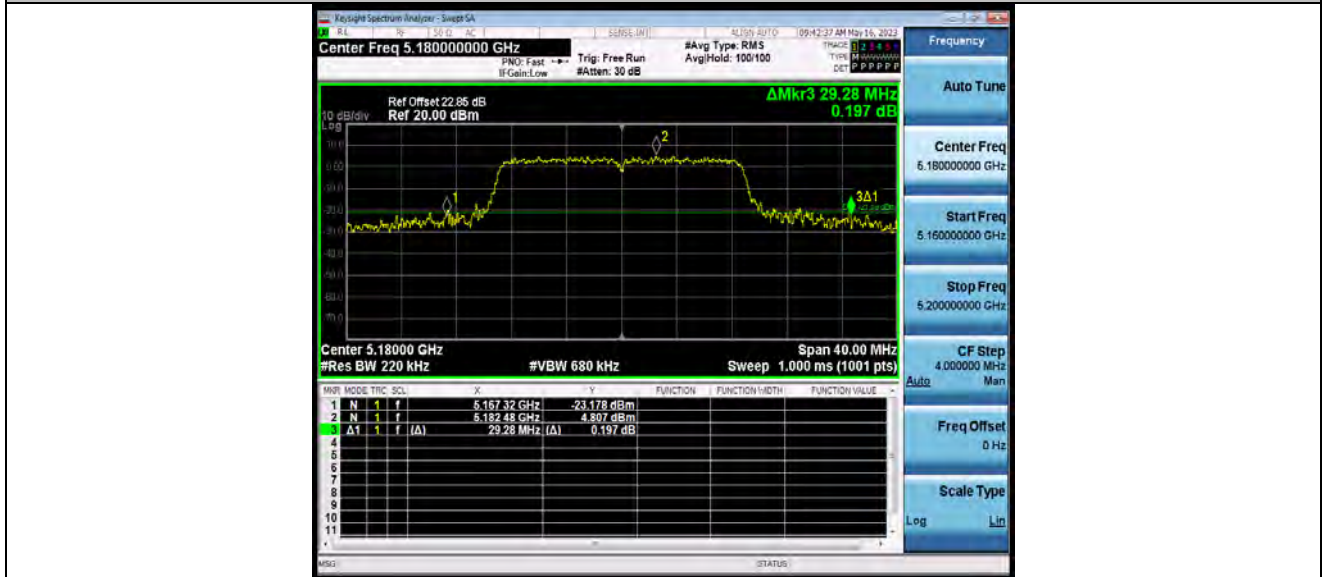

11AC20SISO_Ant1_5200



BUREAU VERITAS

Test Report No.: W7L-P23050004-1RF03



11AC20SISO_Ant1_5240



11AC20SISO_Ant1_5260



**BUREAU
VERITAS**

Test Report No.: W7L-P23050004-1RF03

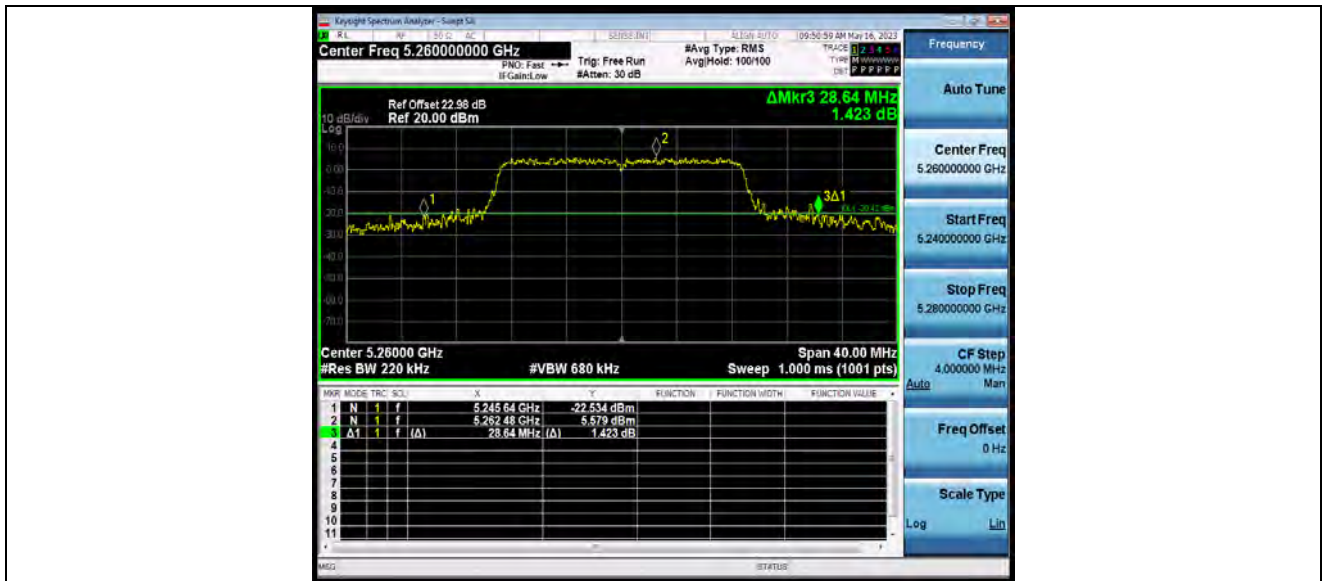

11AC20ISO_Ant1_5300

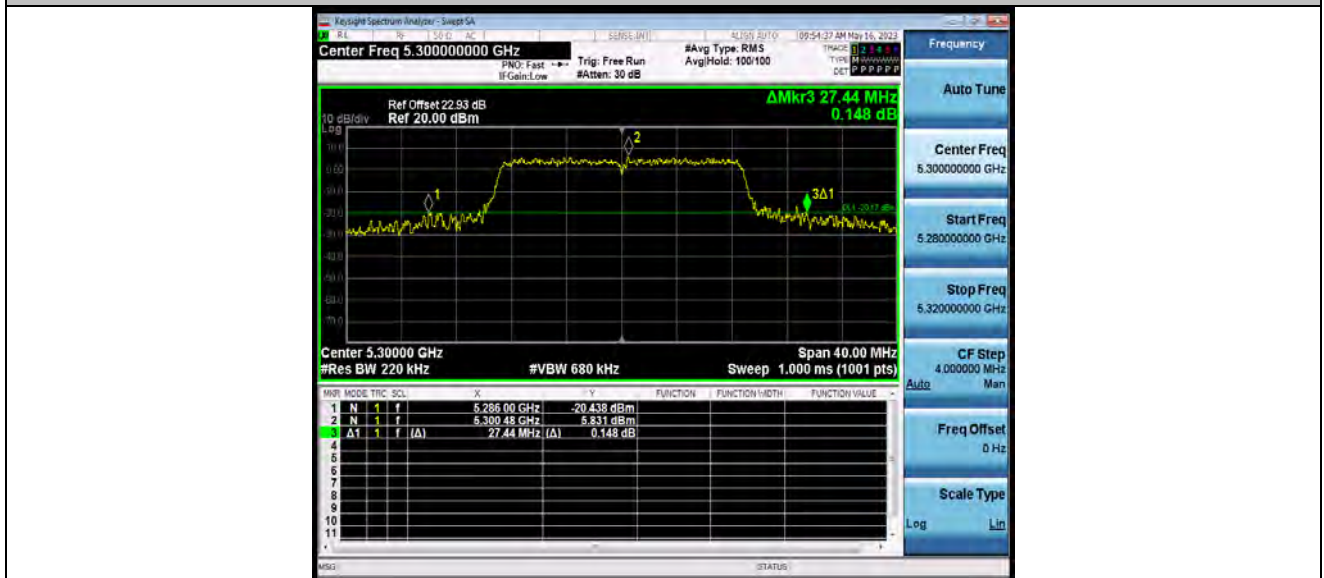

11AC20ISO_Ant1_5320



BUREAU VERITAS

Test Report No.: W7L-P23050004-1RF03



11AC20SISO_Ant1_5500

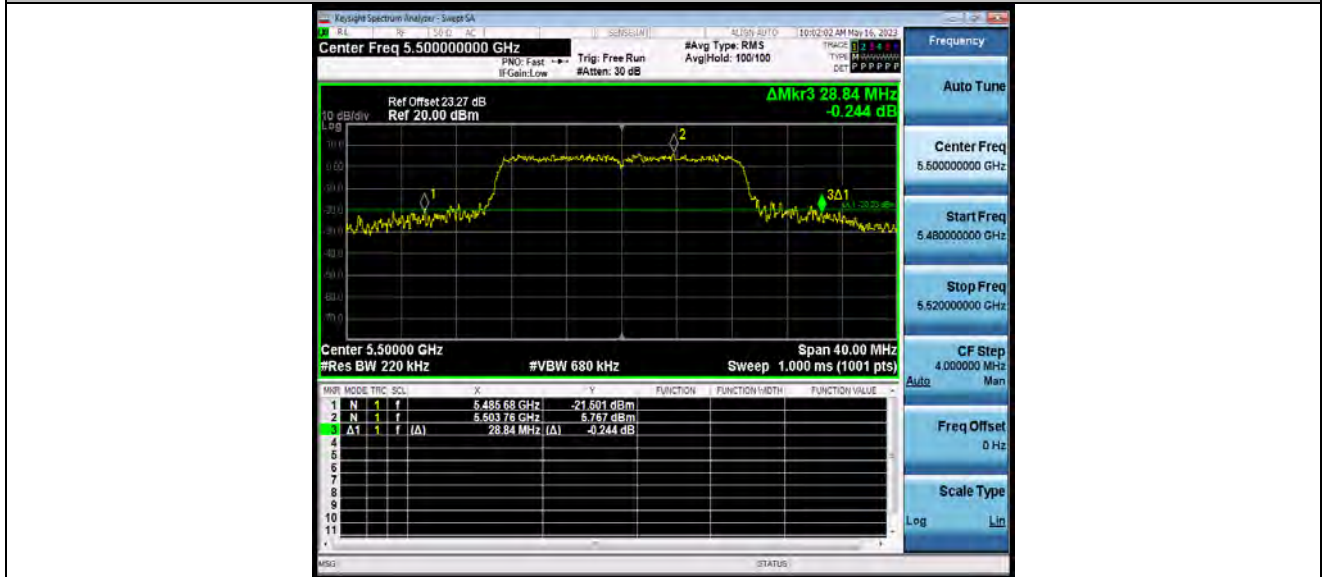

11AC20SISO_Ant1_5580



BUREAU VERITAS

Test Report No.: W7L-P23050004-1RF03



11AC20SISO_Ant1_5700

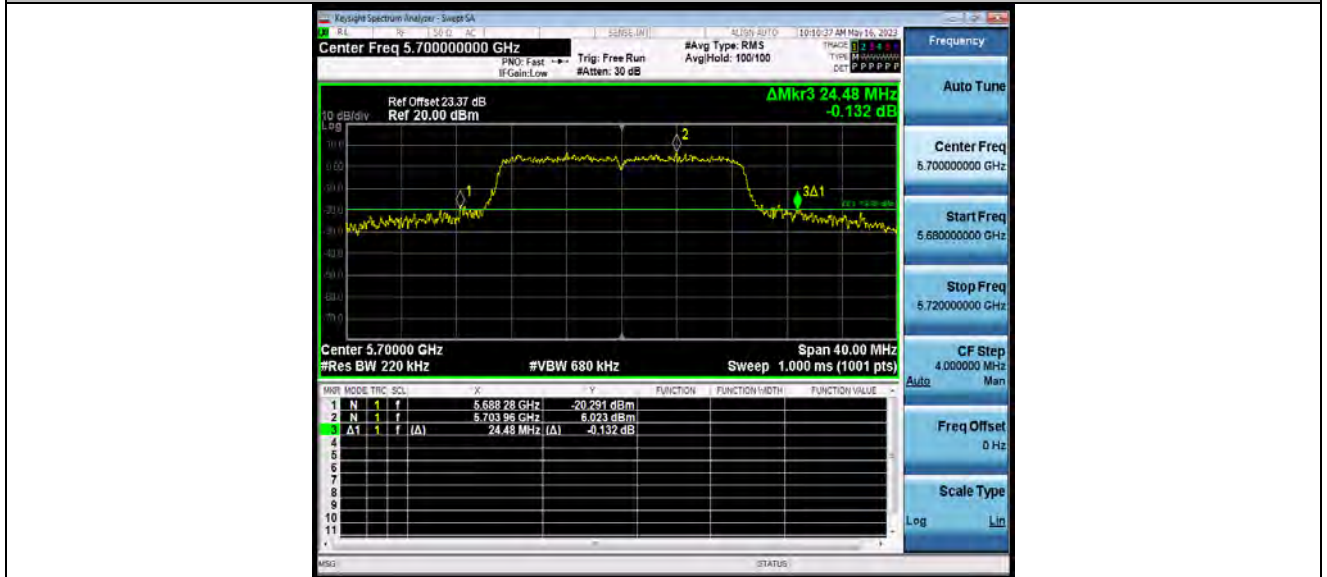

11AC20SISO_Ant1_5745



BUREAU VERITAS

Test Report No.: W7L-P23050004-1RF03



11AC20ISO_Ant1_5785

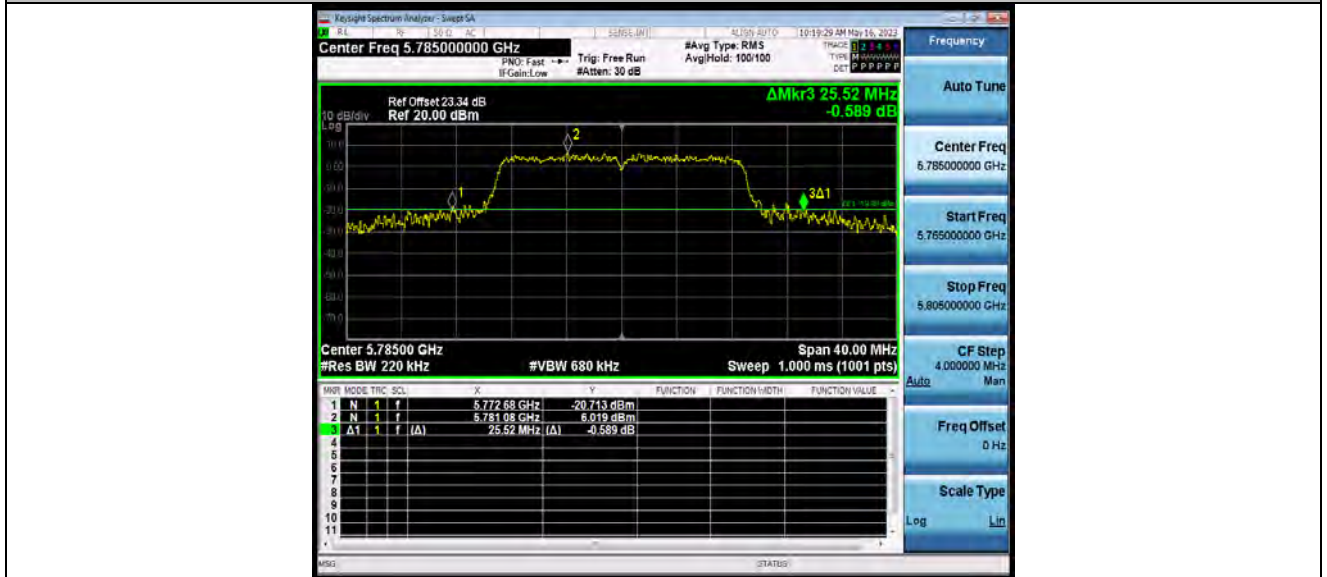

11AC20ISO_Ant1_5825



BUREAU VERITAS

Test Report No.: W7L-P23050004-1RF03



11AC40ISO_Ant1_5190

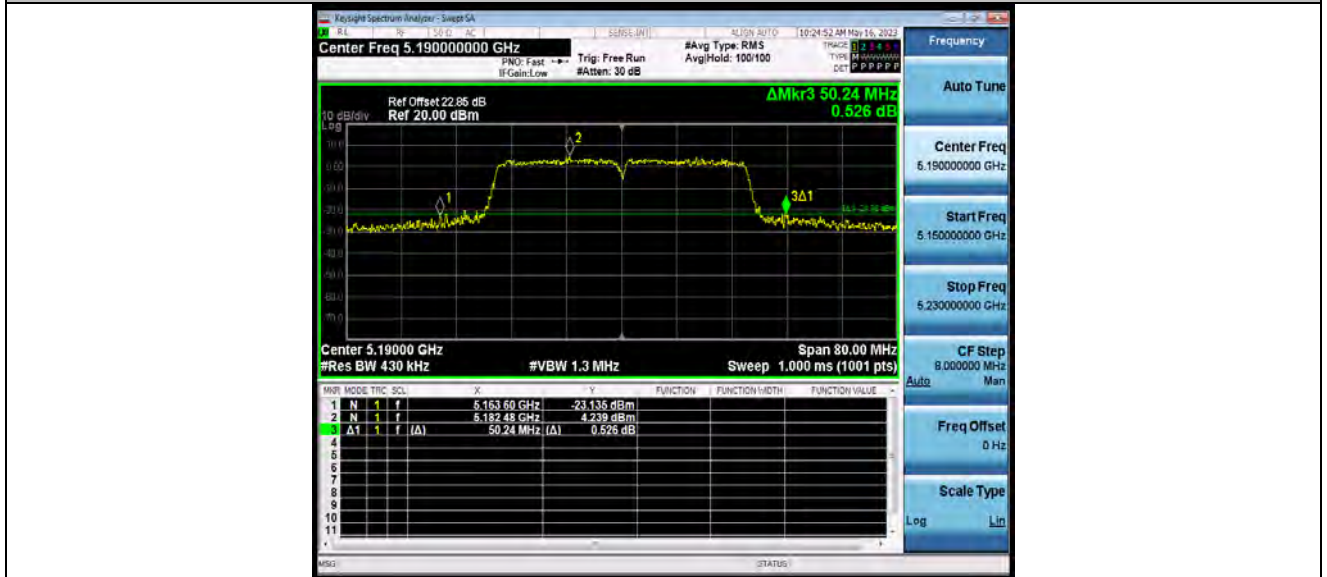

11AC40ISO_Ant1_5230



BUREAU VERITAS

Test Report No.: W7L-P23050004-1RF03



11AC40SISO_Ant1_5270

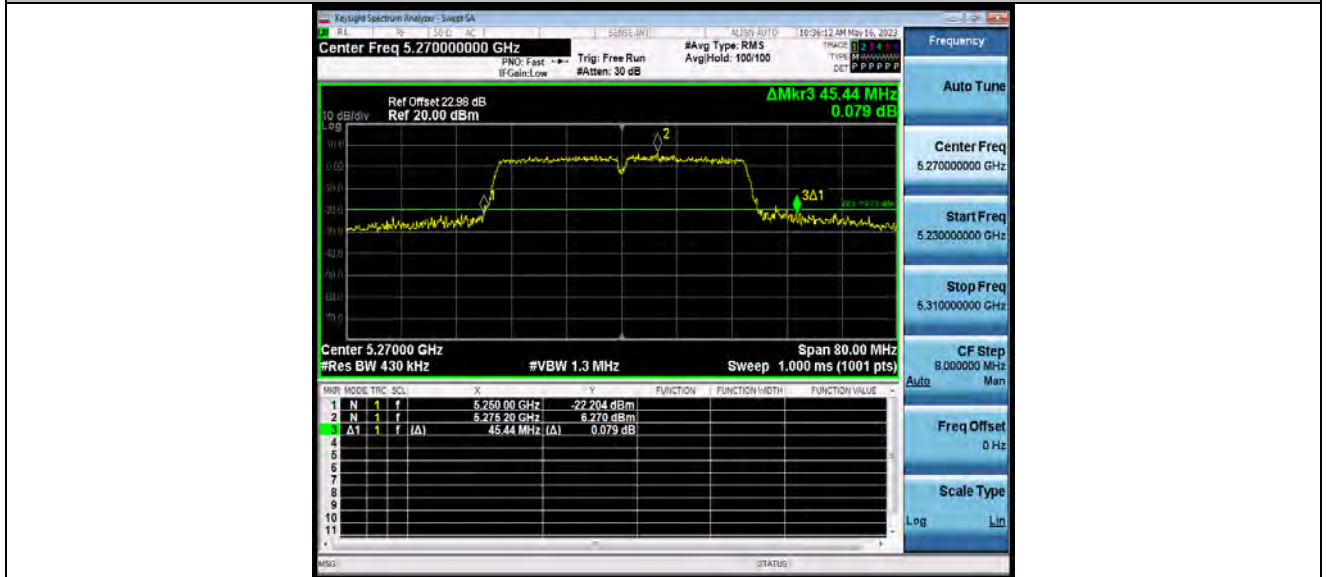

11AC40SISO_Ant1_5310



BUREAU VERITAS

Test Report No.: W7L-P23050004-1RF03



11AC40SISO_Ant1_5510

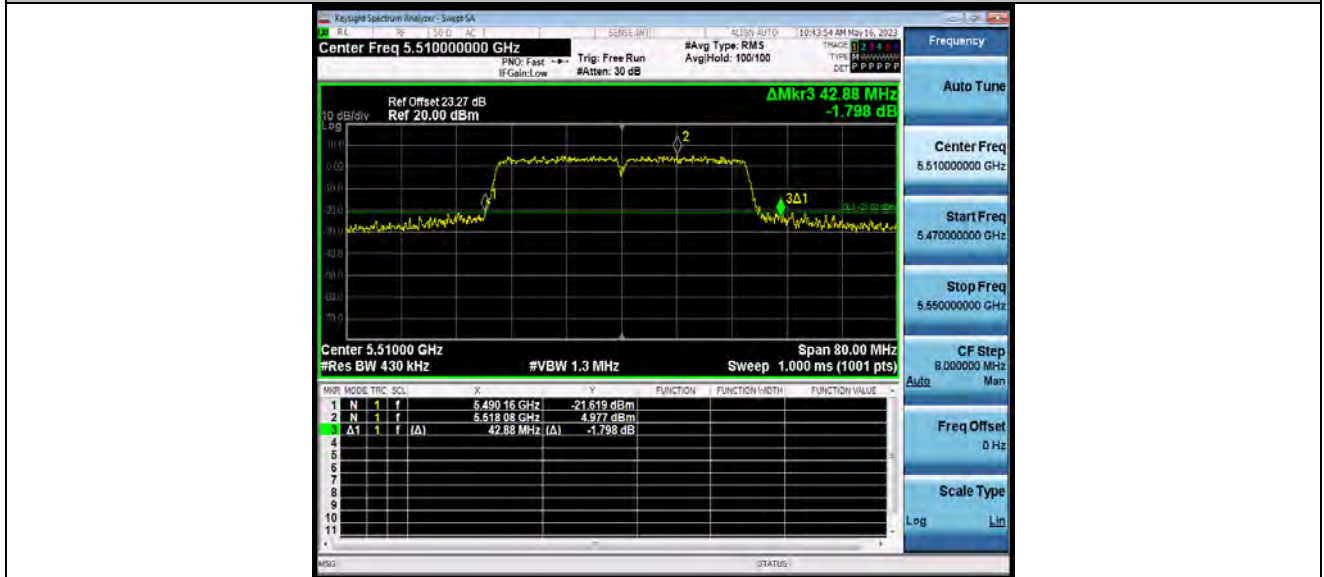

11AC40SISO_Ant1_5550



BUREAU VERITAS

Test Report No.: W7L-P23050004-1RF03

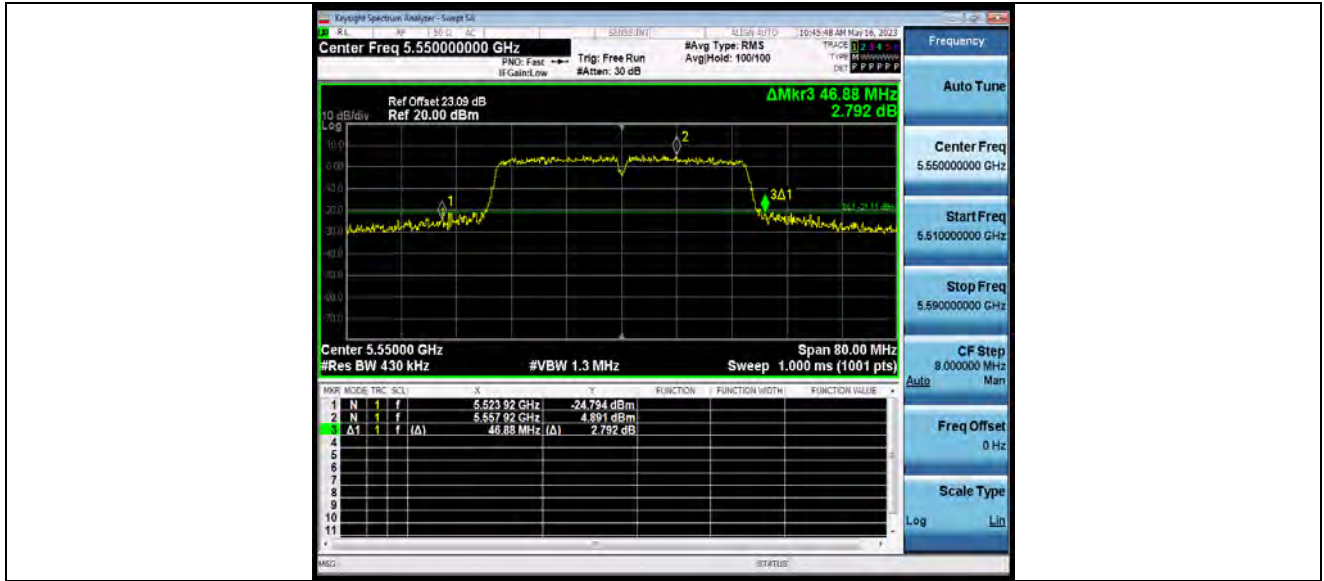

11AC40SISO_Ant1_5670



11AC40SISO_Ant1_5755



BUREAU VERITAS

Test Report No.: W7L-P23050004-1RF03



11AC40SISO_Ant1_5795



11AC80SISO_Ant1_5210



BUREAU VERITAS

Test Report No.: W7L-P23050004-1RF03

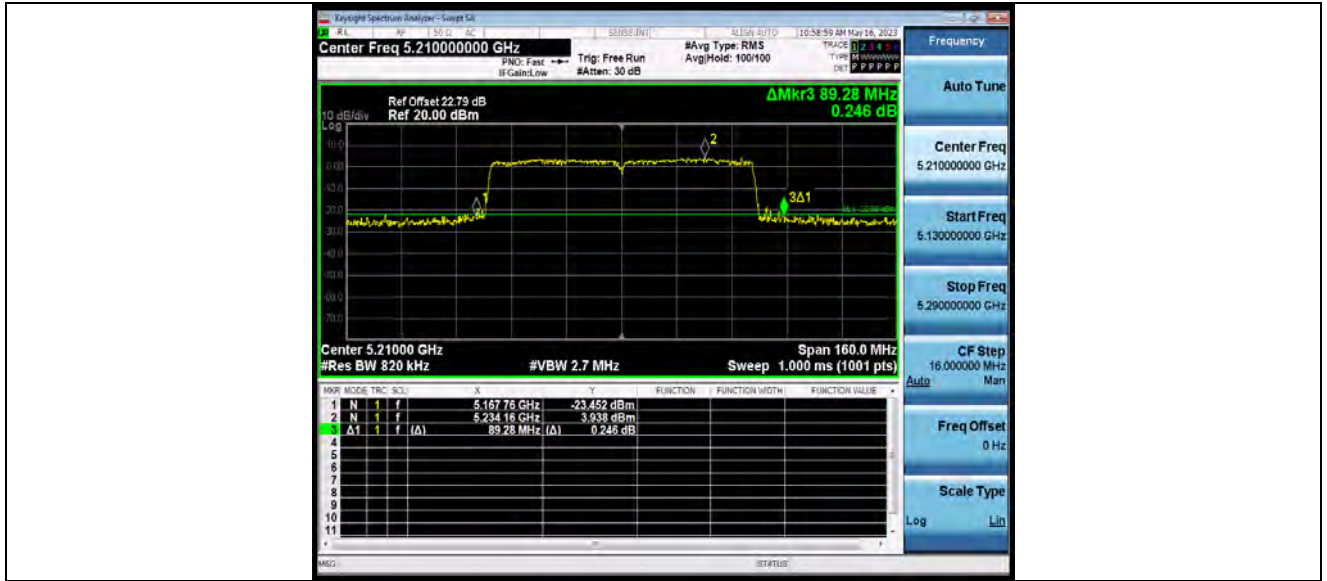

11AC80SISO_Ant1_5290



11AC80SISO_Ant1_5530



BUREAU VERITAS

Test Report No.: W7L-P23050004-1RF03

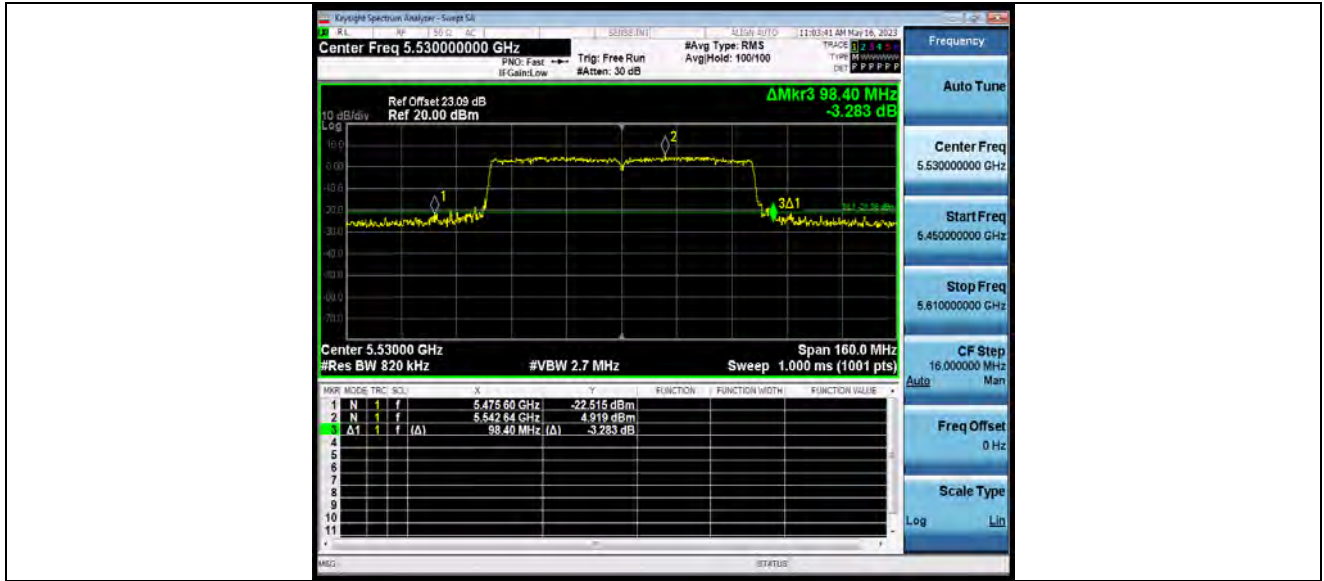

11AC80SISO_Ant1_5610

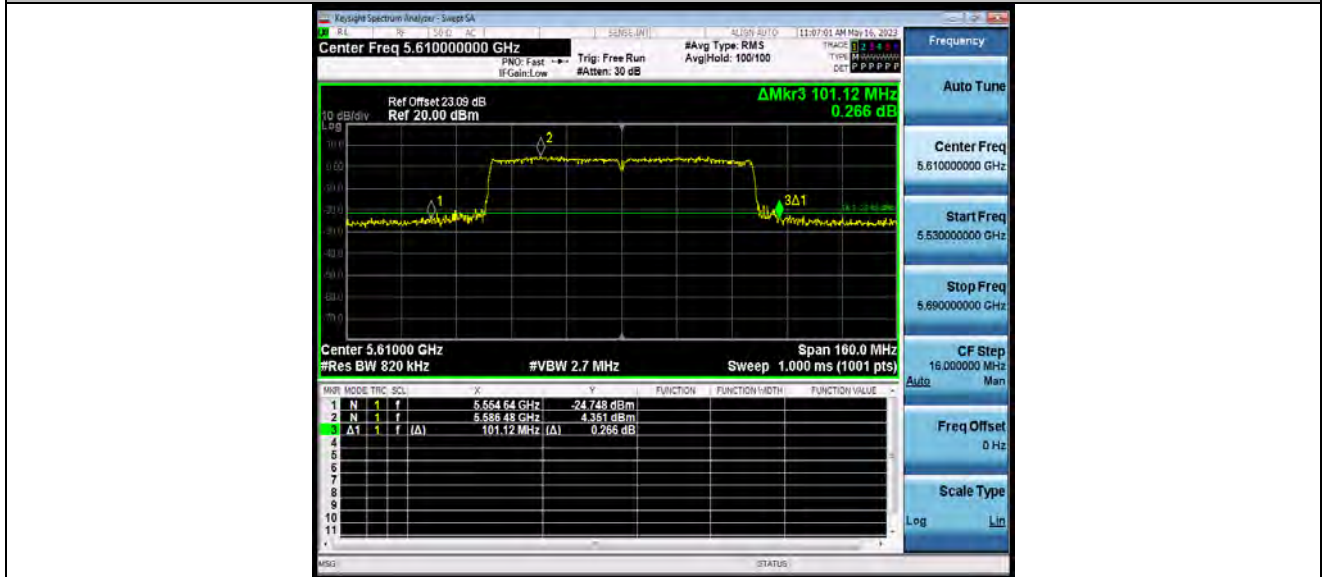

11AC80SISO_Ant1_5775



BUREAU VERITAS

Test Report No.: W7L-P23050004-1RF03

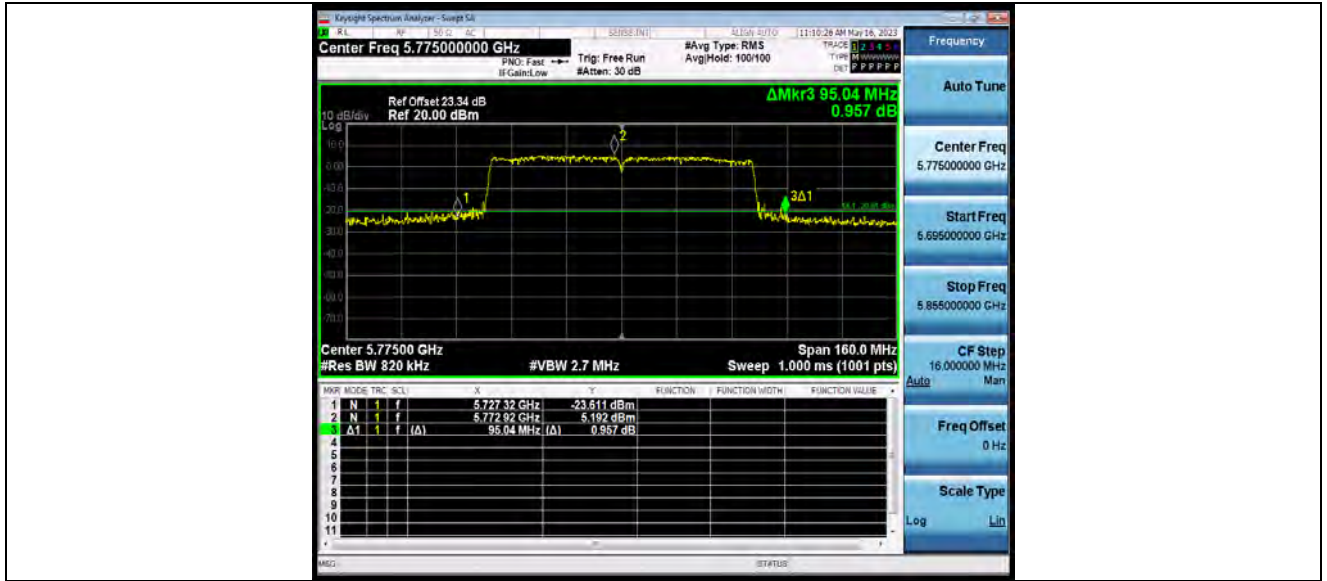



OCCUPIED CHANNEL BANDWIDTH TEST RESULT

TestMode	Antenna	Frequency[MHz]	OCB [MHz]	FL[MHz]	FH[MHz]	Limit[MHz]	Verdict
11A	Ant1	5180	17.124	5171.4446	5188.5686	---	---
		5200	17.198	5191.4179	5208.6159	---	---
		5240	17.165	5231.4651	5248.6301	---	---
		5260	17.238	5251.4107	5268.6487	---	---
		5300	17.170	5291.4496	5308.6196	---	---
		5320	17.205	5311.4139	5328.6189	---	---
		5500	17.142	5491.4139	5508.5559	---	---
		5580	17.144	5571.4538	5588.5978	---	---
		5700	17.180	5691.4109	5708.5909	---	---
		5745	17.149	5736.4340	5753.5830	---	---
		5785	17.161	5776.3961	5793.5571	---	---
		5825	17.163	5816.4380	5833.6010	---	---
11N20SISO	Ant1	5180	17.988	5171.0270	5189.0150	---	---
		5200	18.049	5190.9704	5209.0194	---	---
		5240	18.027	5231.0093	5249.0363	---	---
		5260	18.045	5251.0100	5269.0550	---	---
		5300	17.998	5291.0366	5309.0346	---	---
		5320	18.000	5311.0105	5329.0105	---	---
		5500	18.047	5490.9886	5509.0356	---	---
		5580	17.990	5571.0248	5589.0148	---	---
		5700	18.070	5690.9795	5709.0495	---	---
		5745	18.031	5735.9829	5754.0139	---	---
		5785	17.999	5775.9774	5793.9764	---	---
		5825	18.061	5815.9532	5834.0142	---	---
11N40SISO	Ant1	5190	36.407	5171.8288	5208.2358	---	---
		5230	36.354	5211.8762	5248.2302	---	---
		5270	36.410	5251.8298	5288.2398	---	---
		5310	36.476	5291.7811	5328.2571	---	---
		5510	36.420	5491.7705	5528.1905	---	---
		5550	36.378	5531.8245	5568.2025	---	---
		5670	36.394	5651.7846	5688.1786	---	---



		5755	36.416	5736.7670	5773.1830	---	---
		5795	36.457	5776.7248	5813.1818	---	---
11AC20SISO	Ant1	5180	18.043	5170.9817	5189.0247	---	---
		5200	18.068	5190.9731	5209.0411	---	---
		5240	18.022	5230.9834	5249.0054	---	---
		5260	18.097	5250.9732	5269.0702	---	---
		5300	18.096	5290.9749	5309.0709	---	---
		5320	18.054	5310.9872	5329.0412	---	---
		5500	18.036	5490.9891	5509.0251	---	---
		5580	17.996	5571.0070	5589.0030	---	---
		5700	18.065	5690.9634	5709.0284	---	---
		5745	18.064	5735.9462	5754.0102	---	---
		5785	18.068	5775.9410	5794.0090	---	---
		5825	18.036	5815.9734	5834.0094	---	---
11AC40SISO	Ant1	5190	36.420	5171.8196	5208.2396	---	---
		5230	36.332	5211.8789	5248.2109	---	---
		5270	36.377	5251.8767	5288.2537	---	---
		5310	36.402	5291.8312	5328.2332	---	---
		5510	36.400	5491.7710	5528.1710	---	---
		5550	36.367	5531.8624	5568.2294	---	---
		5670	36.361	5651.8033	5688.1643	---	---
		5755	36.401	5736.7883	5773.1893	---	---
		5795	36.436	5776.7644	5813.2004	---	---
11AC80SISO	Ant1	5210	75.852	5172.1185	5247.9705	---	---
		5290	75.811	5252.1169	5327.9279	---	---
		5530	75.850	5492.0794	5567.9294	---	---
		5610	75.859	5572.0557	5647.9147	---	---
		5775	75.898	5736.9625	5812.8605	---	---



BUREAU VERITAS

Test Report No.: W7L-P23050004-1RF03

TEST GRAPHS

11A_Ant1_5180

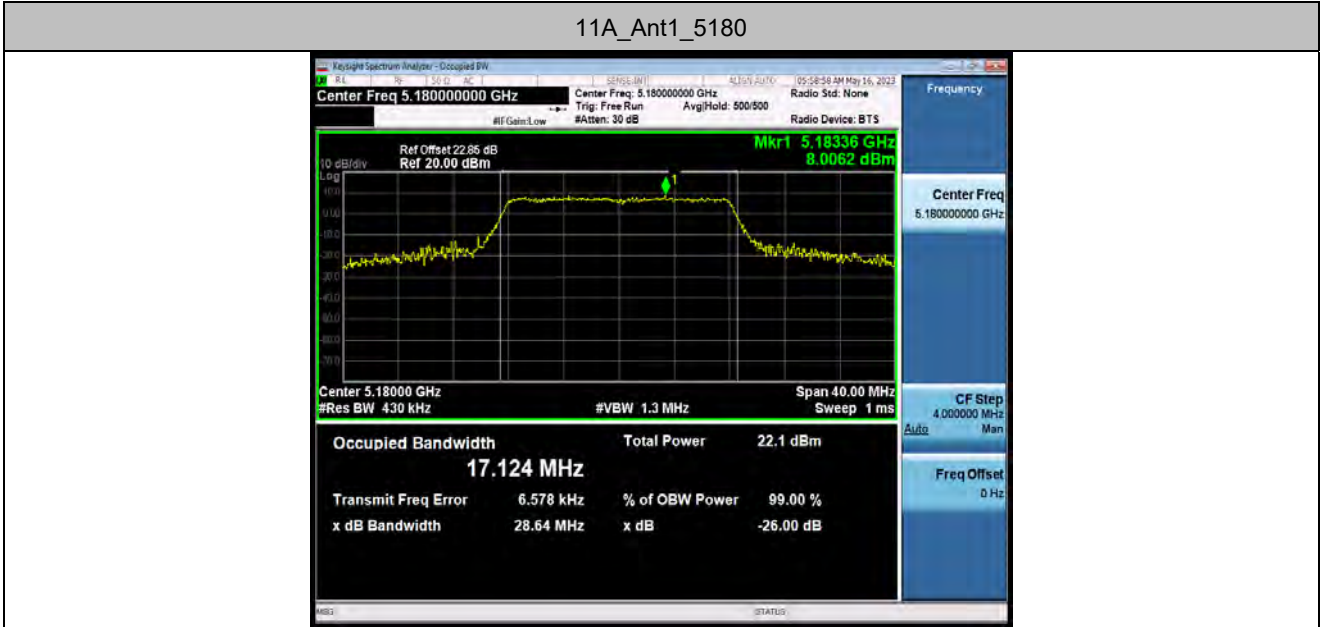

11A_Ant1_5200

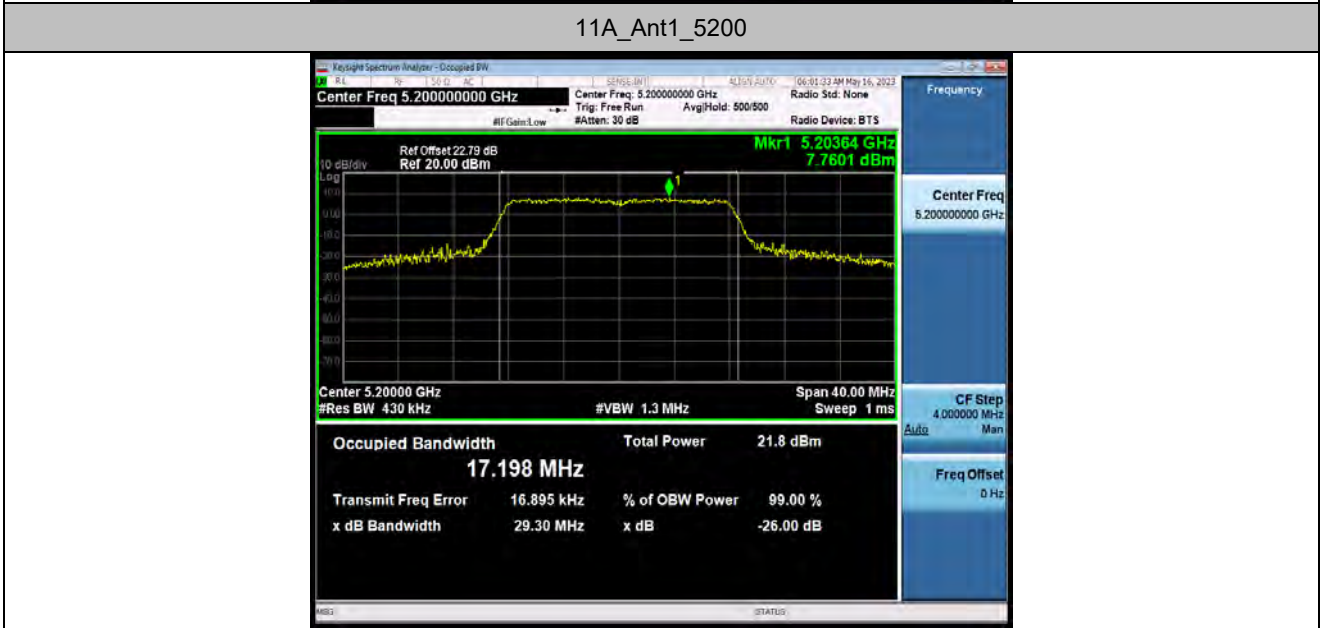

11A_Ant1_5240



BUREAU VERITAS

Test Report No.: W7L-P23050004-1RF03



11A_Ant1_5260



11A_Ant1_5300



BUREAU VERITAS

Test Report No.: W7L-P23050004-1RF03



11A_Ant1_5320



11A_Ant1_5500



BUREAU VERITAS

Test Report No.: W7L-P23050004-1RF03



11A_Ant1_5580



11A_Ant1_5700



BUREAU VERITAS

Test Report No.: W7L-P23050004-1RF03



11A_Ant1_5745



11A_Ant1_5785



BUREAU VERITAS

Test Report No.: W7L-P23050004-1RF03



11A_Ant1_5825



11N20SISO_Ant1_5180

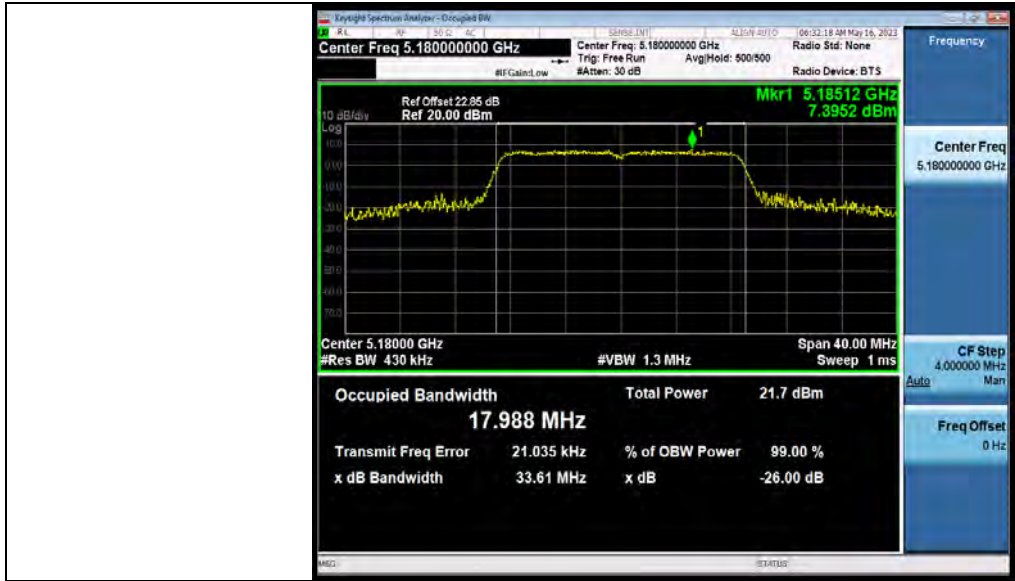

11N20SISO_Ant1_5200

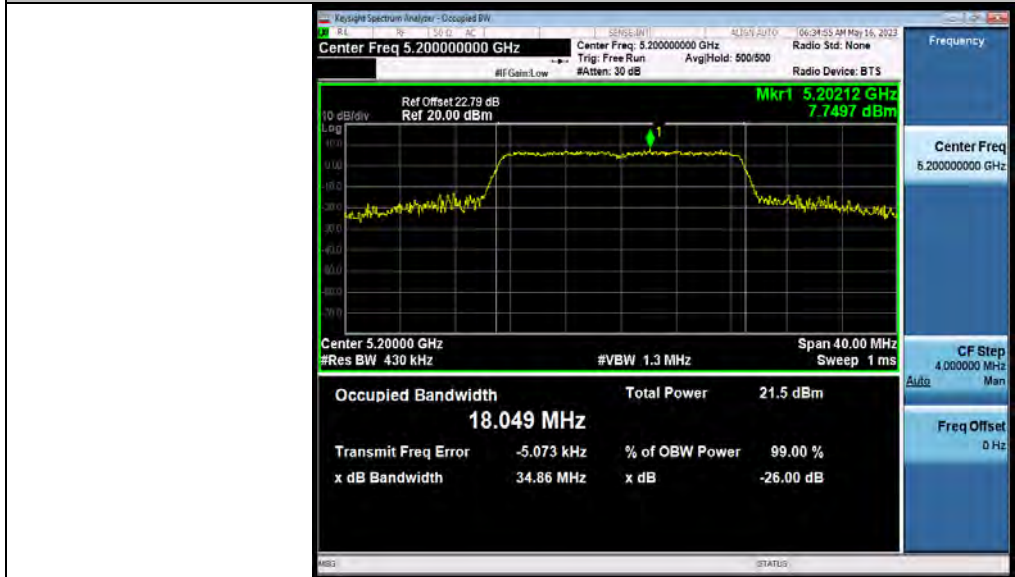

11N20SISO_Ant1_5240



BUREAU VERITAS

Test Report No.: W7L-P23050004-1RF03

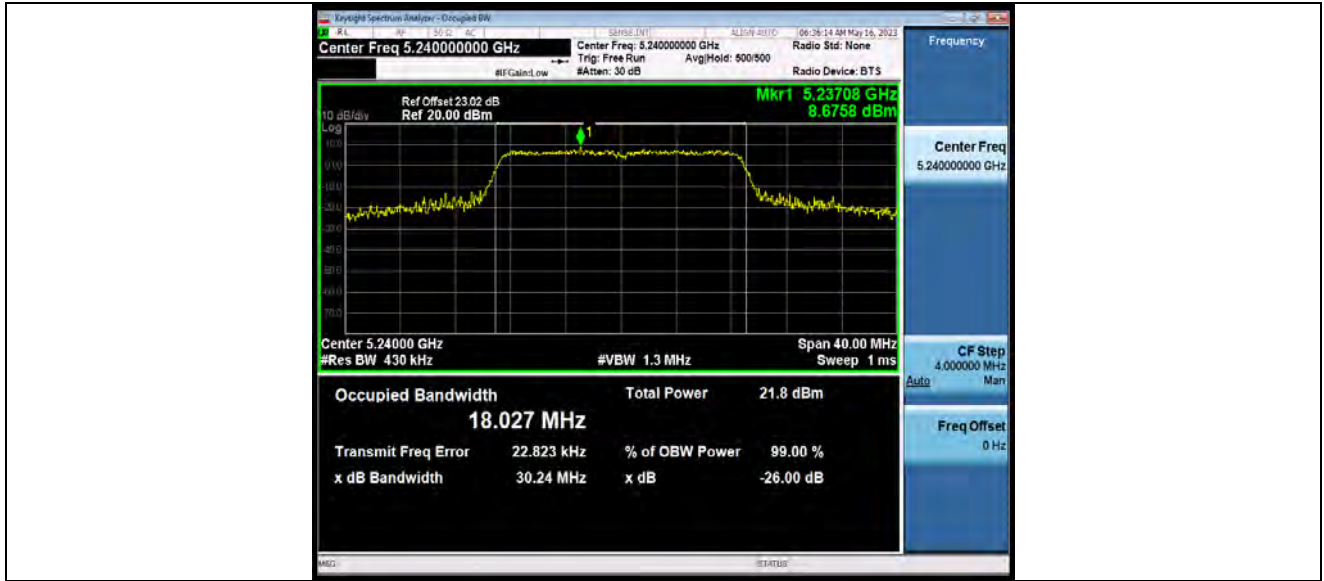

11N20SISO_Ant1_5260



11N20SISO_Ant1_5300



BUREAU VERITAS

Test Report No.: W7L-P23050004-1RF03

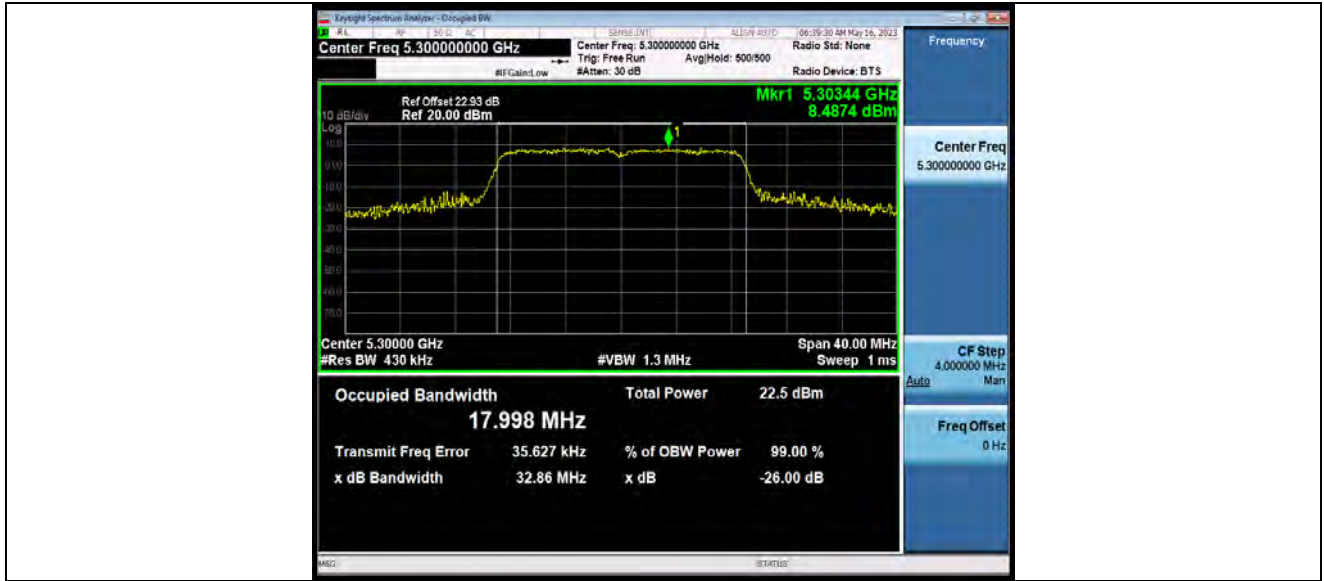

11N20SISO_Ant1_5320



11N20SISO_Ant1_5500



BUREAU VERITAS

Test Report No.: W7L-P23050004-1RF03



11N20SISO_Ant1_5580



11N20SISO_Ant1_5700



BUREAU VERITAS

Test Report No.: W7L-P23050004-1RF03



11N20SISO_Ant1_5745



11N20SISO_Ant1_5785



BUREAU VERITAS

Test Report No.: W7L-P23050004-1RF03



11N20SISO_Ant1_5825



11N40SISO_Ant1_5190



BUREAU VERITAS

Test Report No.: W7L-P23050004-1RF03



11N40SISO_Ant1_5230



11N40SISO_Ant1_5270



BUREAU VERITAS

Test Report No.: W7L-P23050004-1RF03



11N40SISO_Ant1_5310



11N40SISO_Ant1_5510



BUREAU VERITAS

Test Report No.: W7L-P23050004-1RF03

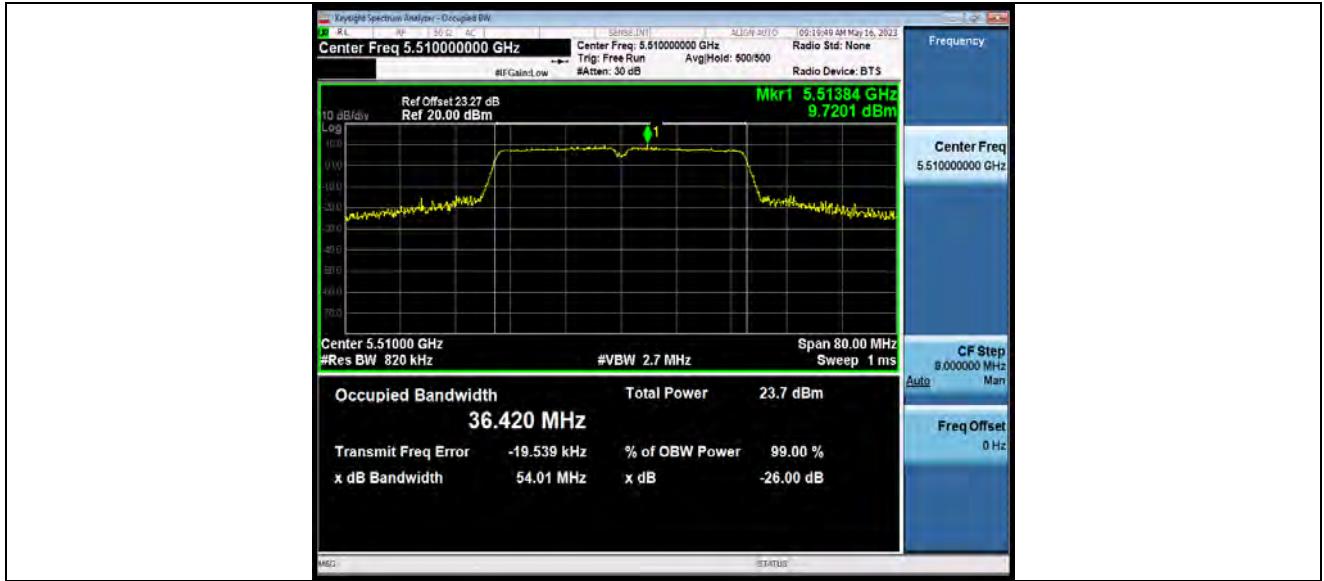

11N40SISO_Ant1_5550



11N40SISO_Ant1_5670



BUREAU VERITAS

Test Report No.: W7L-P23050004-1RF03

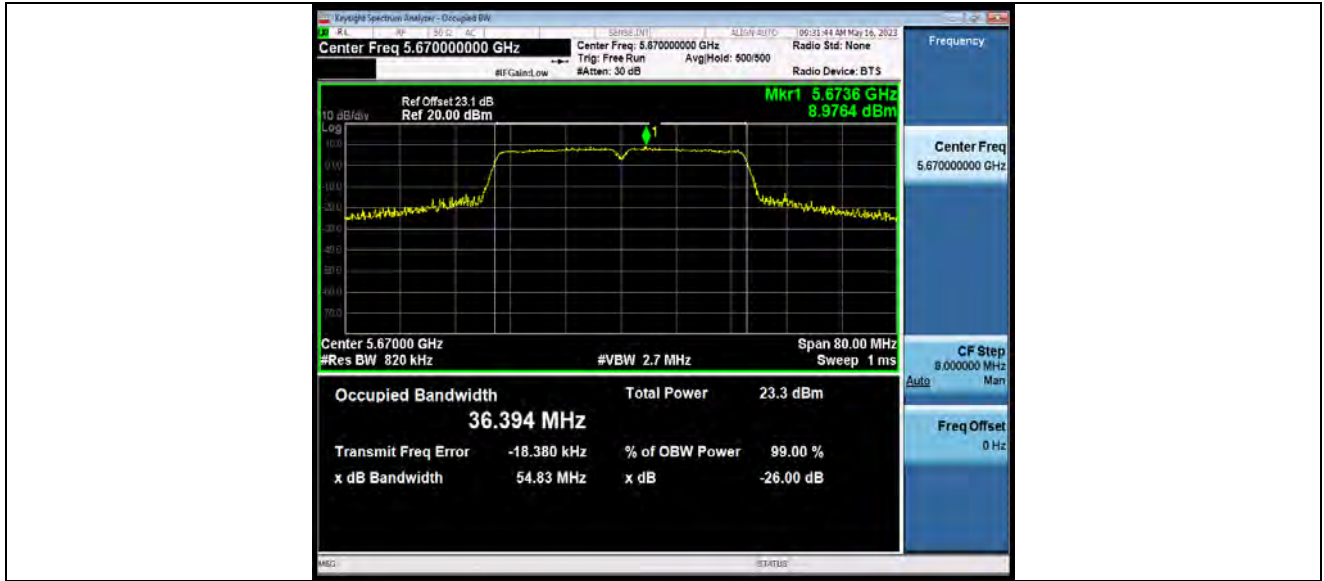

11N40SISO_Ant1_5755



11N40SISO_Ant1_5795



BUREAU VERITAS

Test Report No.: W7L-P23050004-1RF03

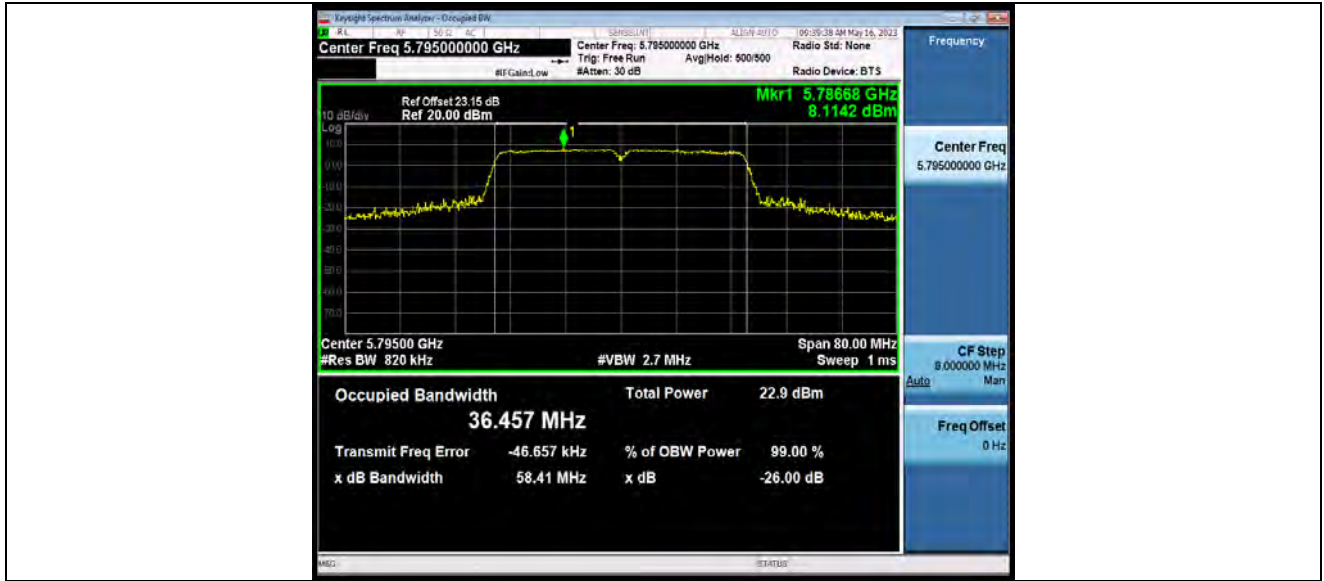

11AC20SISO_Ant1_5180



11AC20SISO_Ant1_5200



BUREAU VERITAS

Test Report No.: W7L-P23050004-1RF03



11AC20SISO_Ant1_5240



11AC20SISO_Ant1_5260



BUREAU VERITAS

Test Report No.: W7L-P23050004-1RF03



11AC20SISO_Ant1_5300



11AC20SISO_Ant1_5320



BUREAU VERITAS

Test Report No.: W7L-P23050004-1RF03

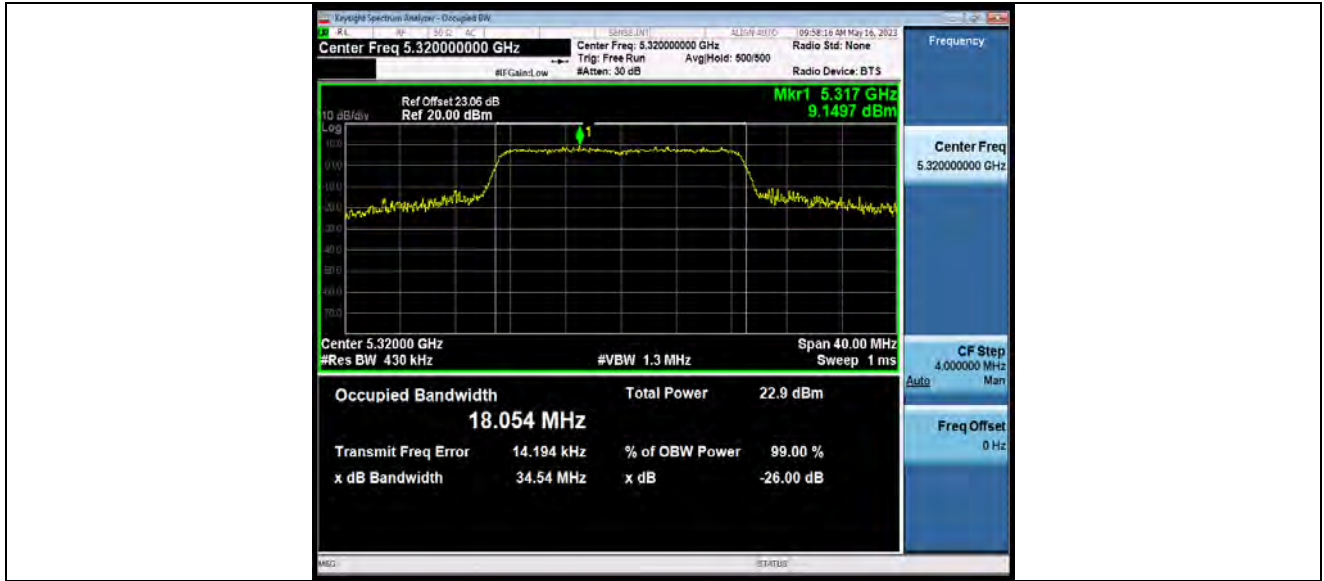

11AC20SISO_Ant1_5500



11AC20SISO_Ant1_5580



BUREAU VERITAS

Test Report No.: W7L-P23050004-1RF03



11AC20SISO_Ant1_5700



11AC20SISO_Ant1_5745



BUREAU VERITAS

Test Report No.: W7L-P23050004-1RF03



11AC20SISO_Ant1_5785



11AC20SISO_Ant1_5825



BUREAU VERITAS

Test Report No.: W7L-P23050004-1RF03



11AC40SISO_Ant1_5190



11AC40SISO_Ant1_5230



BUREAU VERITAS

Test Report No.: W7L-P23050004-1RF03

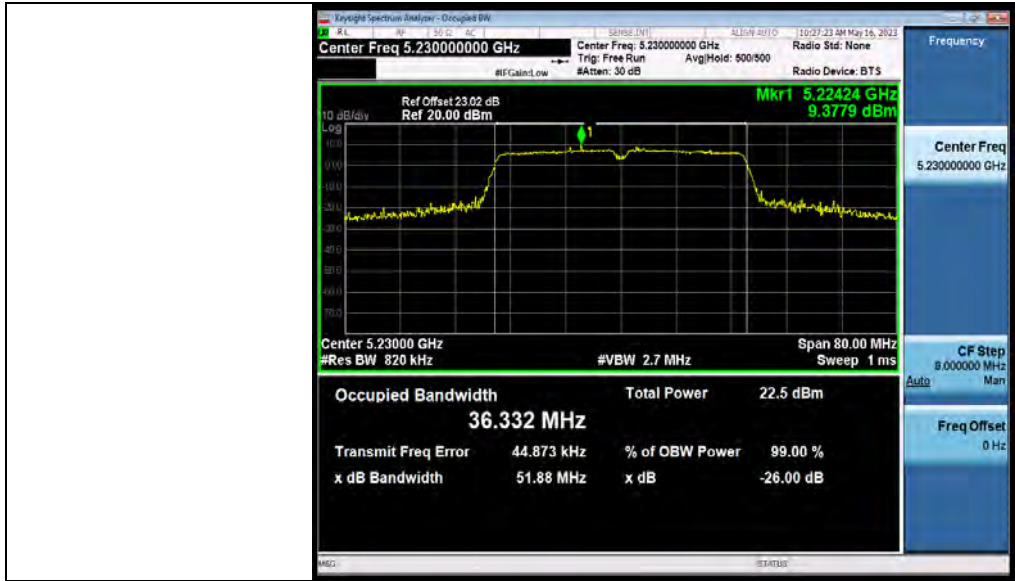

11AC40SISO_Ant1_5270

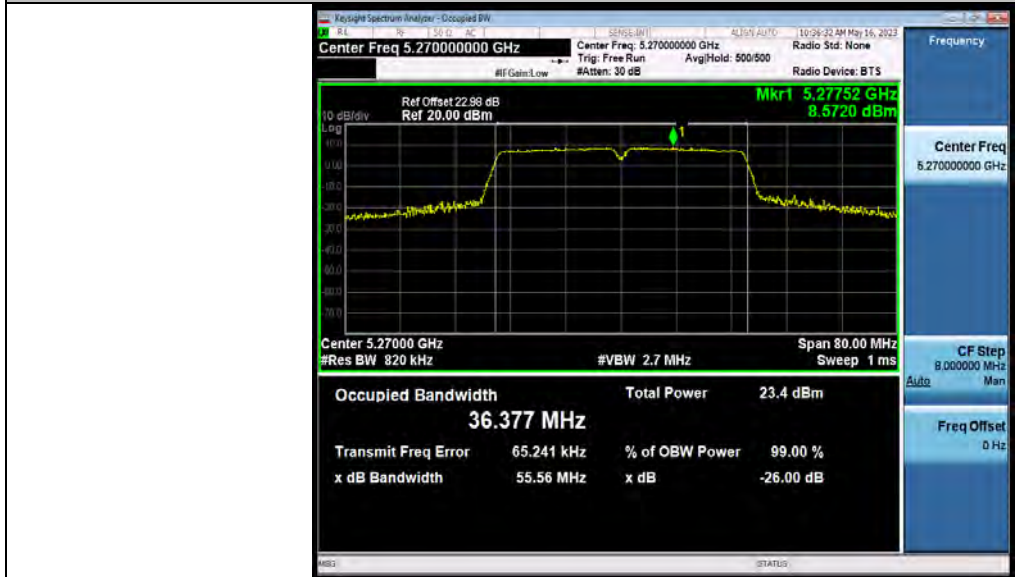

11AC40SISO_Ant1_5310



BUREAU VERITAS

Test Report No.: W7L-P23050004-1RF03



11AC40SISO_Ant1_5510



11AC40SISO_Ant1_5550



BUREAU VERITAS

Test Report No.: W7L-P23050004-1RF03



11AC40SISO_Ant1_5670



11AC40SISO_Ant1_5755



BUREAU VERITAS

Test Report No.: W7L-P23050004-1RF03



11AC40SISO_Ant1_5795



11AC80SISO_Ant1_5210



BUREAU VERITAS

Test Report No.: W7L-P23050004-1RF03

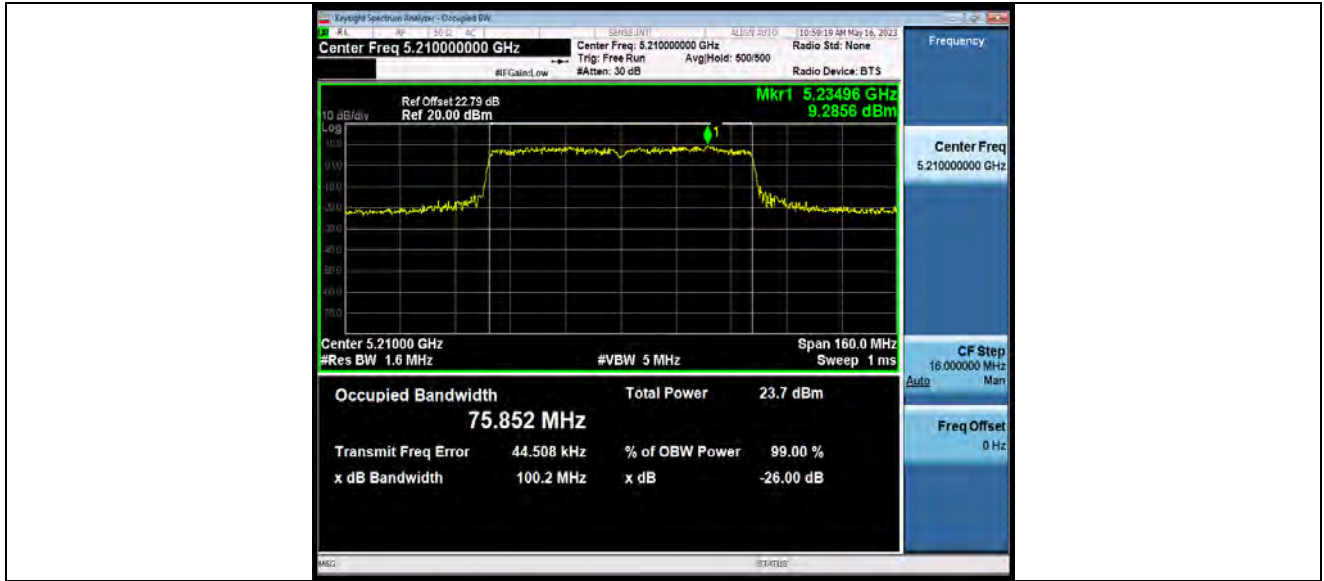

11AC80SISO_Ant1_5290



11AC80SISO_Ant1_5530



BUREAU VERITAS

Test Report No.: W7L-P23050004-1RF03



11AC80SISO_Ant1_5610



11AC80SISO_Ant1_5775



**BUREAU
VERITAS**

Test Report No.: W7L-P23050004-1RF03





MIN EMISSION BANDWIDTH

TEST RESULT B4

TestMode	Antenna	Frequency[MHz]	6db EBW [MHz]	FL[MHz]	FH[MHz]	Limit[MHz]	Verdict
11A	Ant1	5745	16.320	5736.840	5753.160	0.5	PASS
		5785	16.320	5776.840	5793.160	0.5	PASS
		5825	16.320	5816.840	5833.160	0.5	PASS
11N20SISO	Ant1	5745	17.520	5736.240	5753.760	0.5	PASS
		5785	17.040	5776.440	5793.480	0.5	PASS
		5825	17.520	5816.240	5833.760	0.5	PASS
11N40SISO	Ant1	5755	35.760	5737.000	5772.760	0.5	PASS
		5795	35.680	5777.080	5812.760	0.5	PASS
11AC20SISO	Ant1	5745	17.360	5736.360	5753.720	0.5	PASS
		5785	17.280	5776.240	5793.520	0.5	PASS
		5825	17.280	5816.240	5833.520	0.5	PASS
11AC40SISO	Ant1	5755	35.200	5737.400	5772.600	0.5	PASS
		5795	35.840	5777.080	5812.920	0.5	PASS
11AC80SISO	Ant1	5775	75.360	5737.240	5812.600	0.5	PASS



BUREAU VERITAS

Test Report No.: W7L-P23050004-1RF03

TEST GRAPHS B4

11A_Ant1_5745

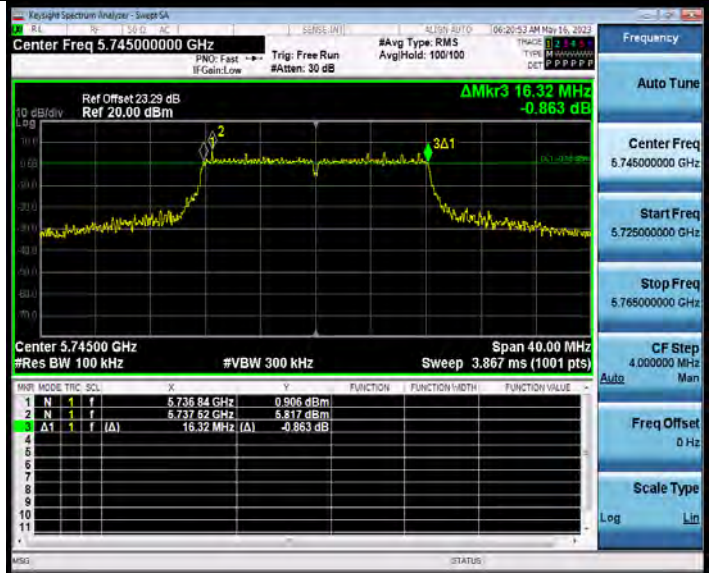

11A_Ant1_5785

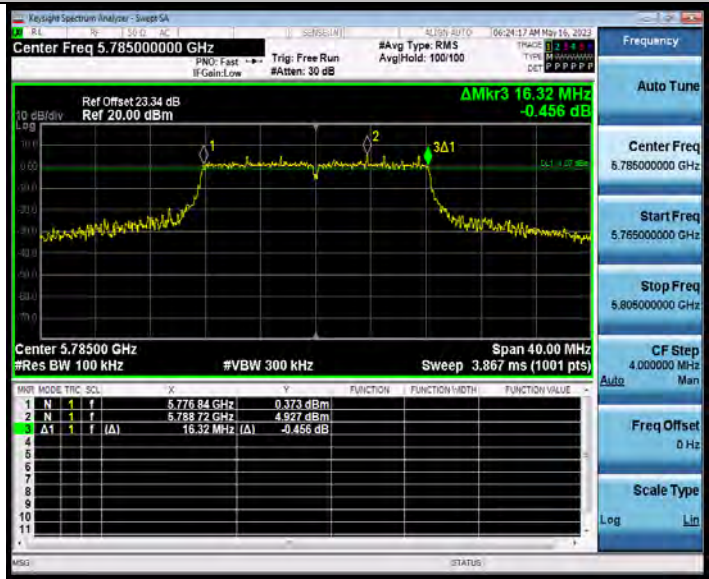

11A_Ant1_5825



BUREAU VERITAS

Test Report No.: W7L-P23050004-1RF03

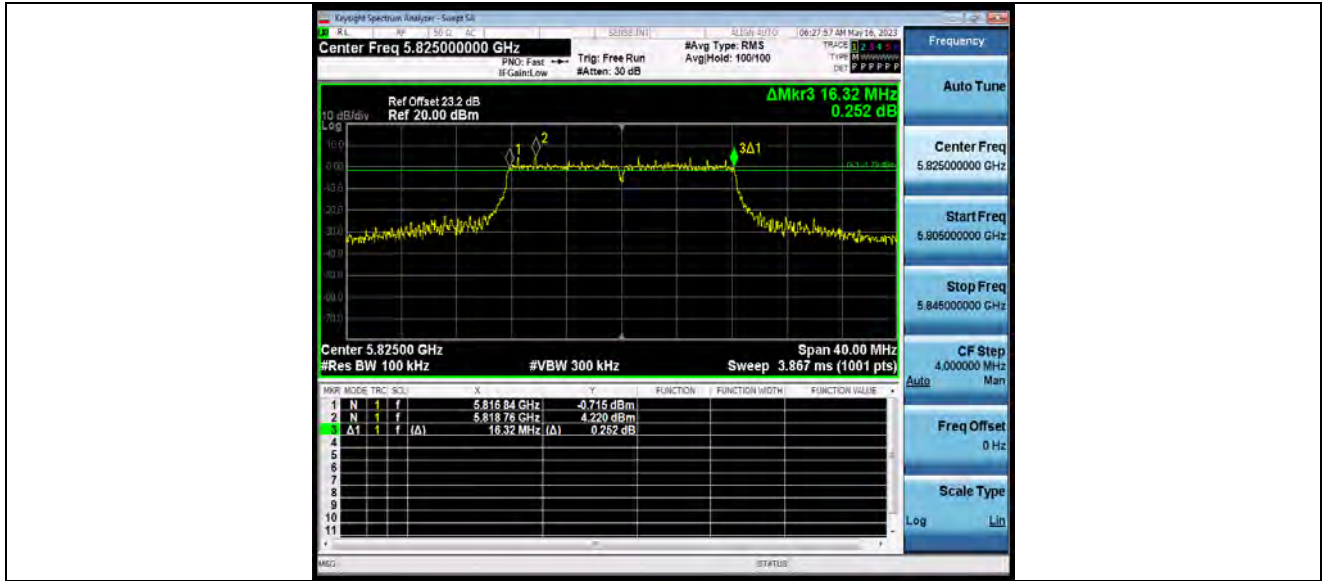

11N20SISO_Ant1_5745

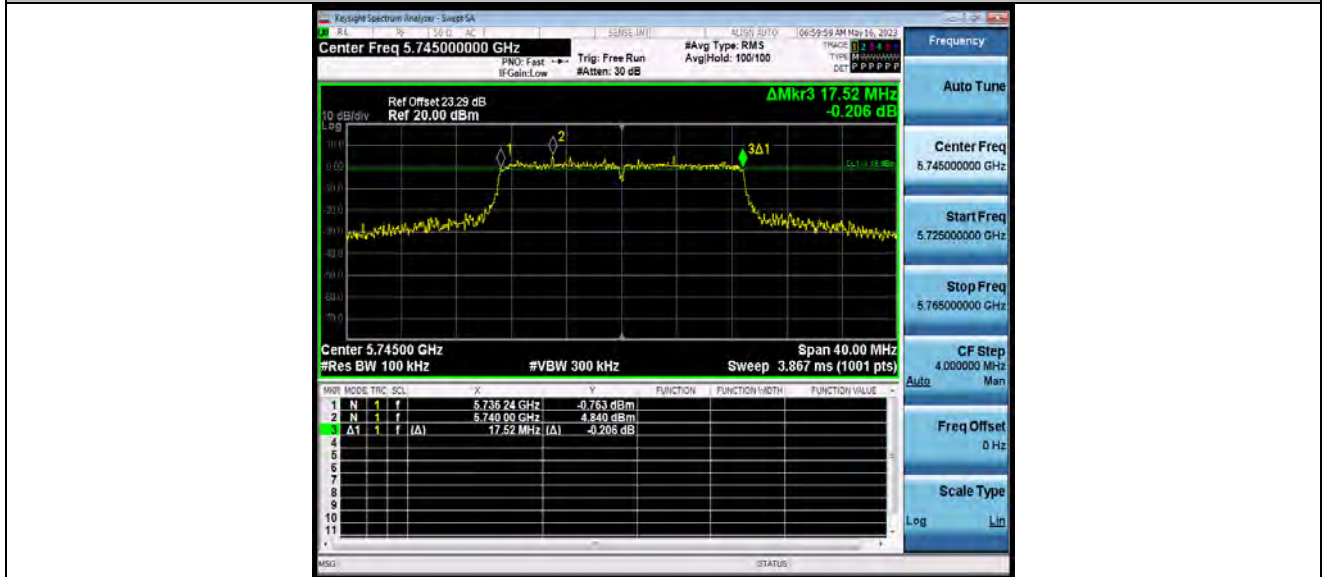

11N20SISO_Ant1_5785



**BUREAU
VERITAS**

Test Report No.: W7L-P23050004-1RF03

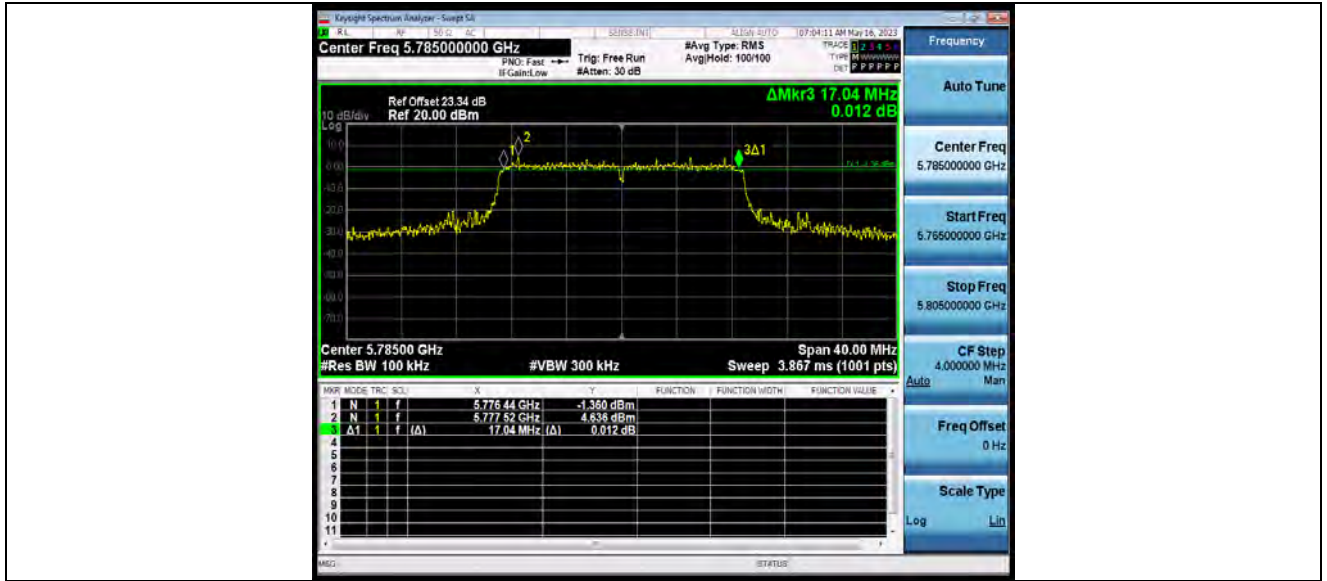

11N20SISO_Ant1_5825

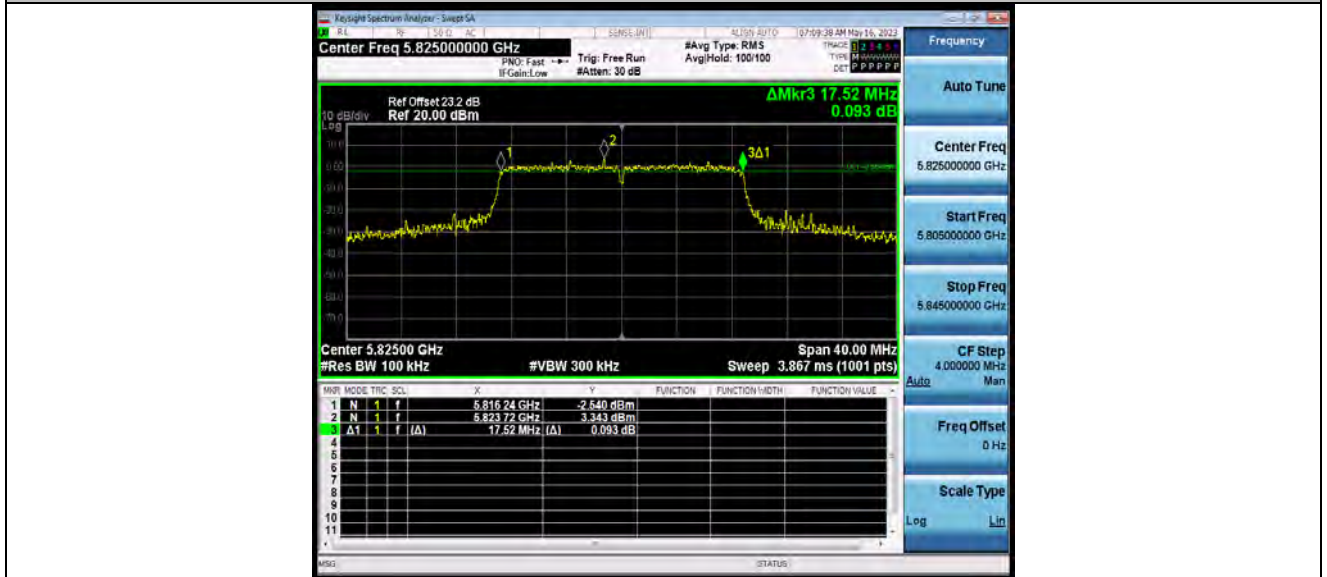

11N40SISO_Ant1_5755



BUREAU VERITAS

Test Report No.: W7L-P23050004-1RF03

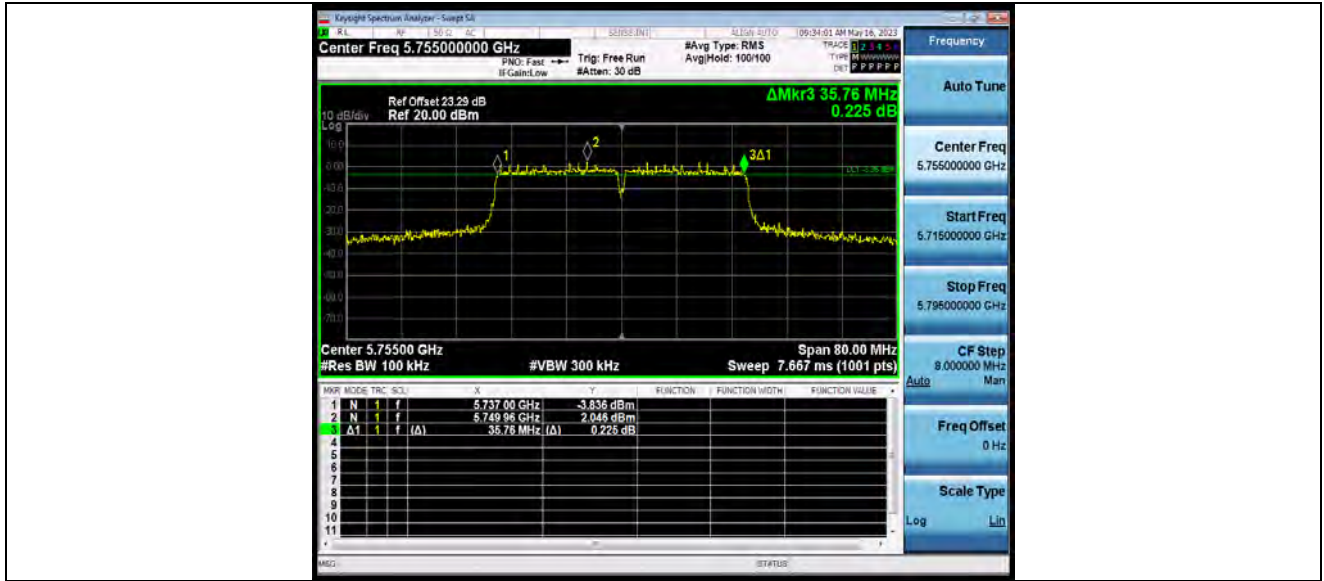

11N40SISO_Ant1_5795

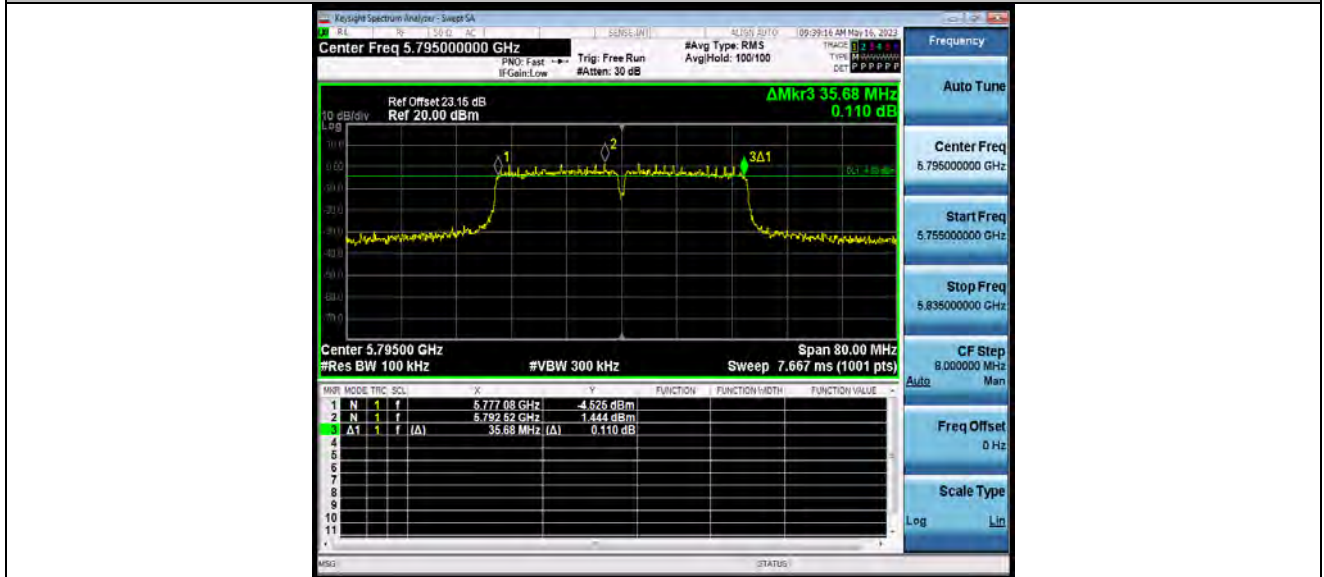

11AC20SISO_Ant1_5745



BUREAU VERITAS

Test Report No.: W7L-P23050004-1RF03

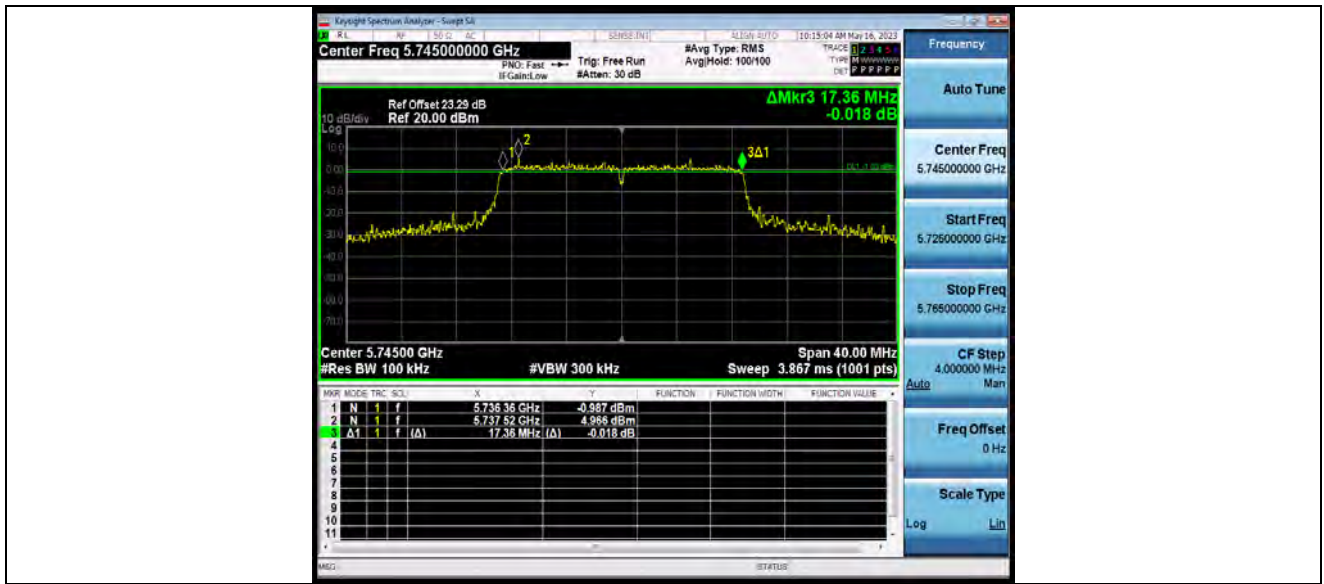

11AC20SISO_Ant1_5785

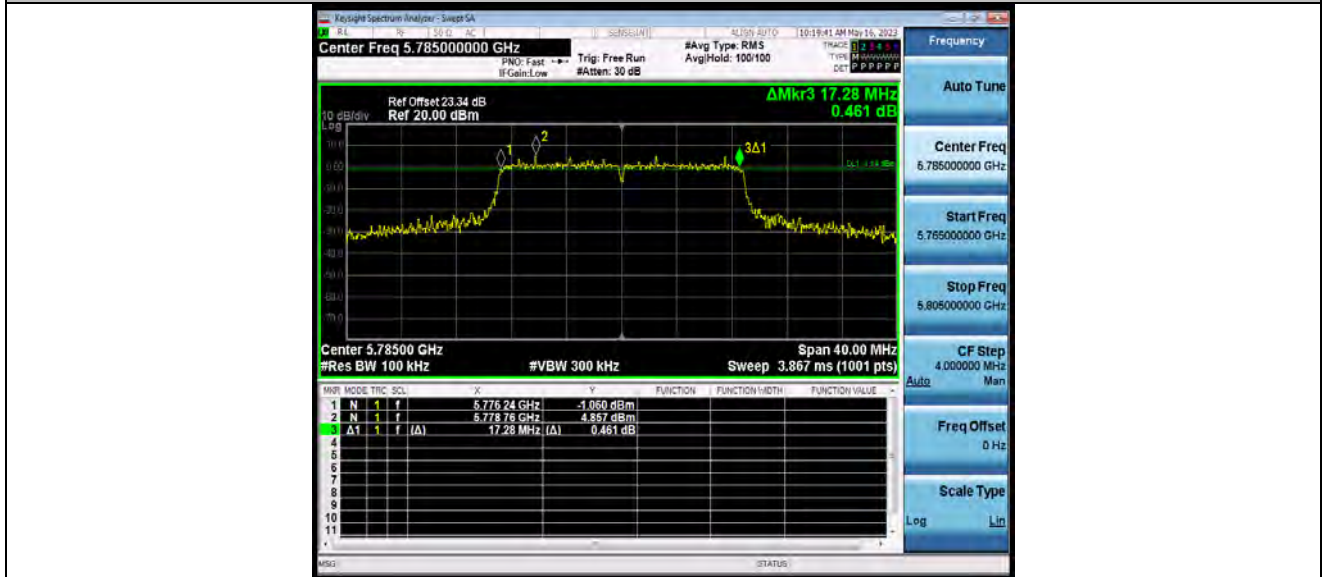

11AC20SISO_Ant1_5825



BUREAU VERITAS

Test Report No.: W7L-P23050004-1RF03

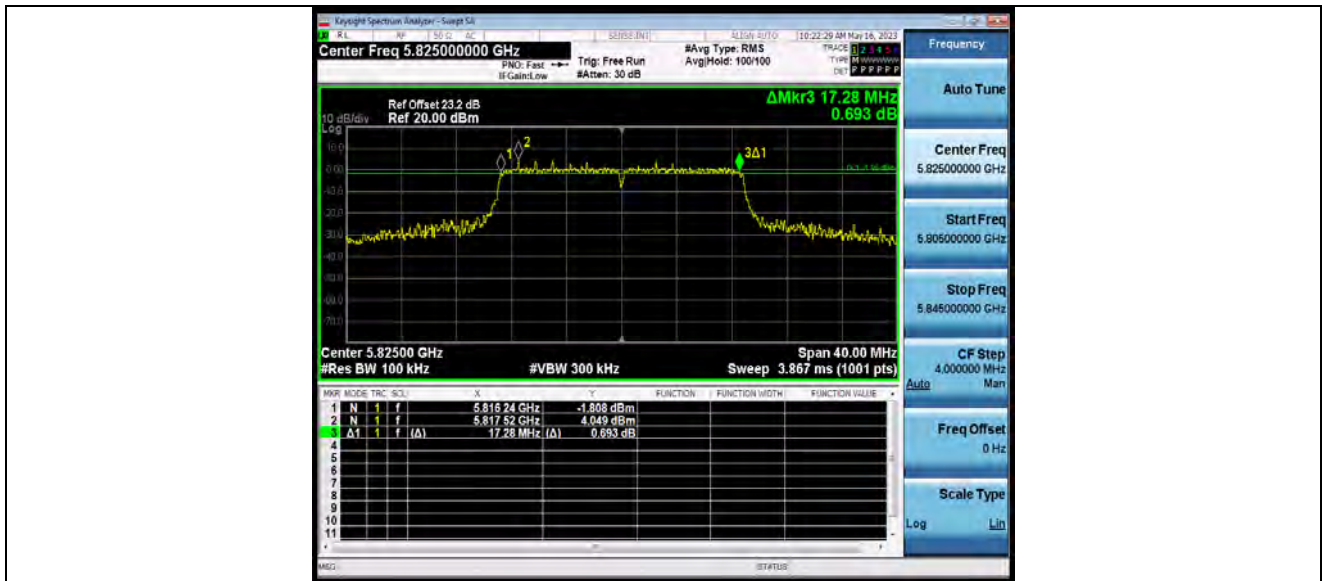

11AC40ISO_Ant1_5755

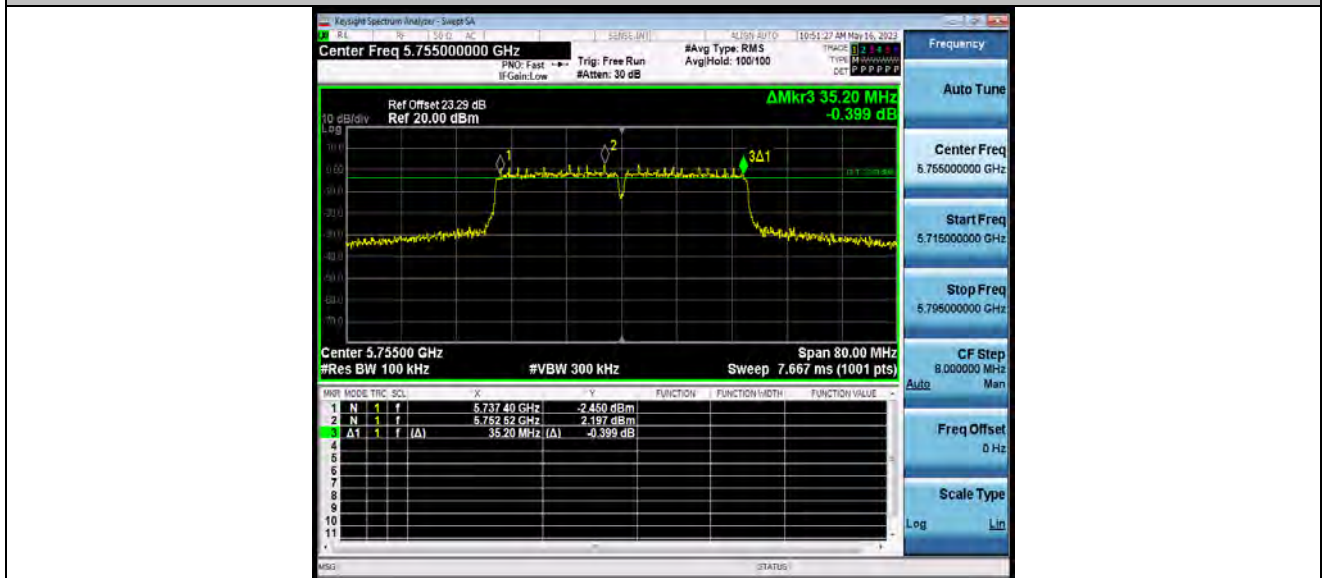

11AC40ISO_Ant1_5795



**BUREAU
VERITAS**

Test Report No.: W7L-P23050004-1RF03

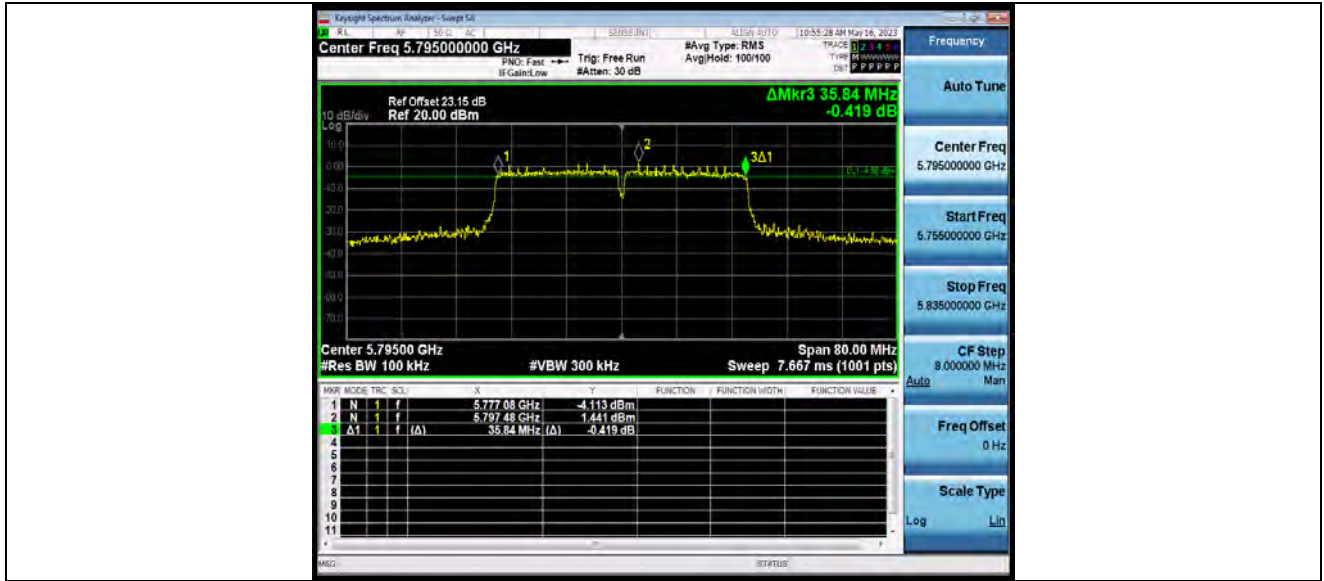

11AC80ISO_Ant1_5775

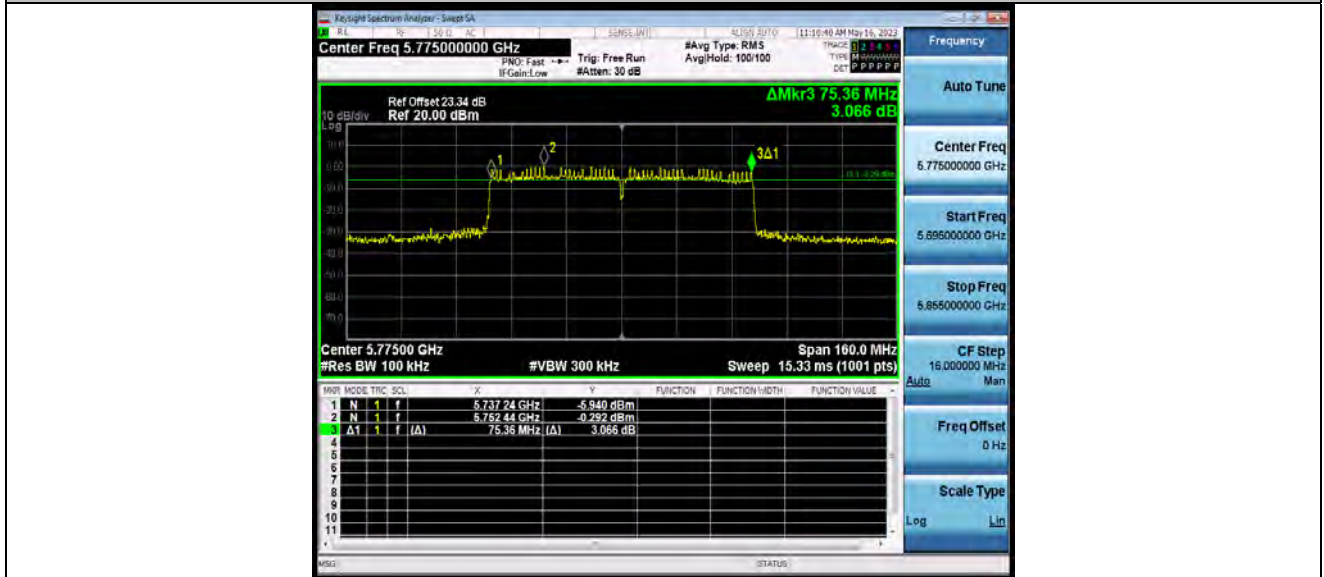



DUTY CYCLE TEST RESULT

TestMode	Antenna	Frequency[MHz]	Transmission Duration [ms]	Transmission Period [ms]	Duty Cycle [%]
11A	Ant1	5180	1.36	1.50	90.67
		5200	1.36	1.51	90.07
		5240	1.36	1.52	89.47
		5260	1.36	1.52	89.47
		5300	1.36	1.52	89.47
		5320	1.36	1.50	90.67
		5500	1.36	1.50	90.67
		5580	1.36	1.50	90.67
		5700	1.37	1.52	90.13
		5745	1.37	1.51	90.73
		5785	1.36	1.51	90.07
		5825	1.37	1.51	90.73
11N20SISO	Ant1	5180	1.27	1.43	88.81
		5200	1.28	1.44	88.89
		5240	1.27	1.42	89.44
		5260	1.28	1.42	90.14
		5300	1.27	1.42	89.44
		5320	1.27	1.43	88.81
		5500	1.28	1.44	88.89
		5580	1.28	1.44	88.89
		5700	1.27	1.44	88.19
		5745	1.28	1.42	90.14
		5785	1.28	1.53	83.66
		5825	1.28	1.42	90.14
11N40SISO	Ant1	5190	0.64	0.80	80.00
		5230	0.64	0.80	80.00
		5270	0.63	0.80	78.75
		5310	0.63	0.79	79.75
		5510	0.63	0.80	78.75
		5550	0.64	0.80	80.00



		5670	0.64	0.79	81.01
		5755	0.64	0.80	80.00
		5795	0.64	1.06	60.38
11AC20SISO	Ant1	5180	1.28	1.43	89.51
		5200	1.28	1.43	89.51
		5240	1.28	1.44	88.89
		5260	1.29	1.44	89.58
		5300	1.29	1.43	90.21
		5320	1.28	1.45	88.28
		5500	1.28	1.44	88.89
		5580	1.28	1.43	89.51
		5700	1.28	1.44	88.89
		5745	1.28	1.42	90.14
		5785	1.29	1.46	88.36
		5825	1.29	1.43	90.21
		11AC40SISO	Ant1	5190	0.64
5230	0.64			0.81	79.01
5270	0.64			0.80	80.00
5310	0.64			0.78	82.05
5510	0.64			0.80	80.00
5550	0.64			0.82	78.05
5670	0.64			0.78	82.05
5755	0.64			0.78	82.05
5795	0.64			0.78	82.05
11AC80SISO	Ant1	5210	0.32	0.49	65.31
		5290	0.32	0.49	65.31
		5530	0.32	0.48	66.67
		5610	0.32	0.48	66.67
		5775	0.32	0.48	66.67



BUREAU VERITAS

Test Report No.: W7L-P23050004-1RF03

TEST GRAPHS

11A_Ant1_5180

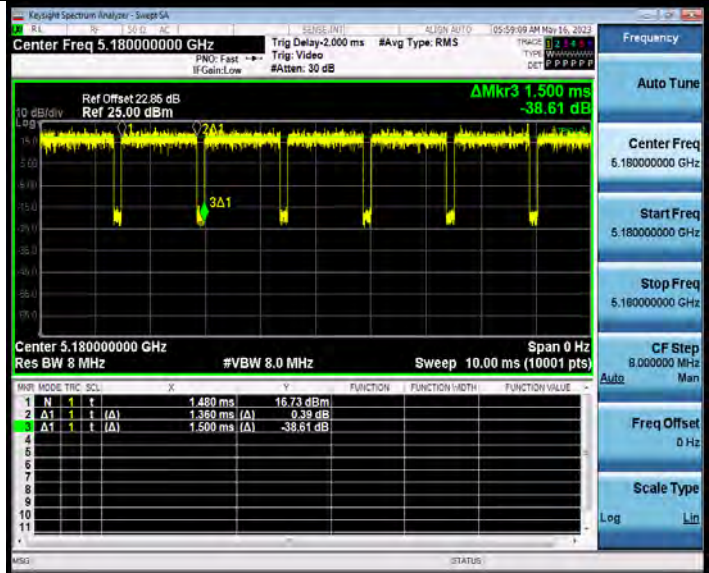

11A_Ant1_5200

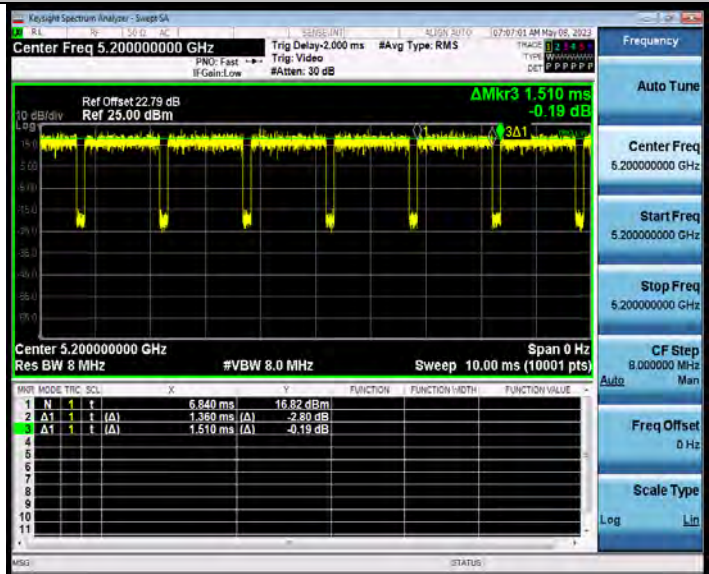

11A_Ant1_5240



BUREAU VERITAS

Test Report No.: W7L-P23050004-1RF03

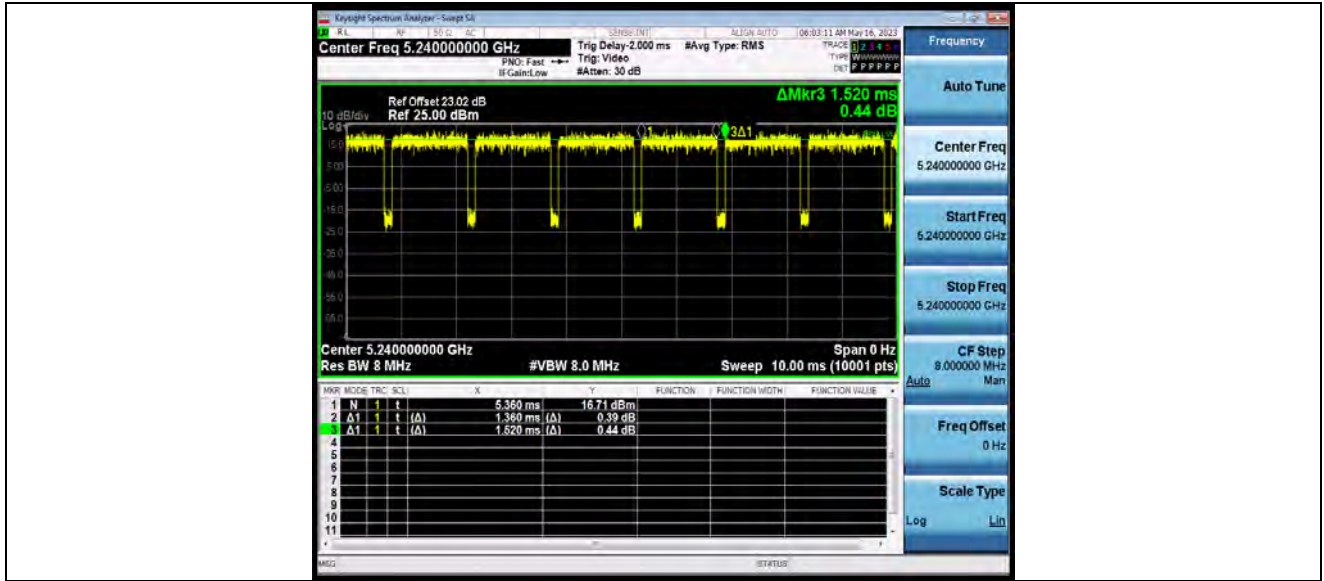

11A_Ant1_5260

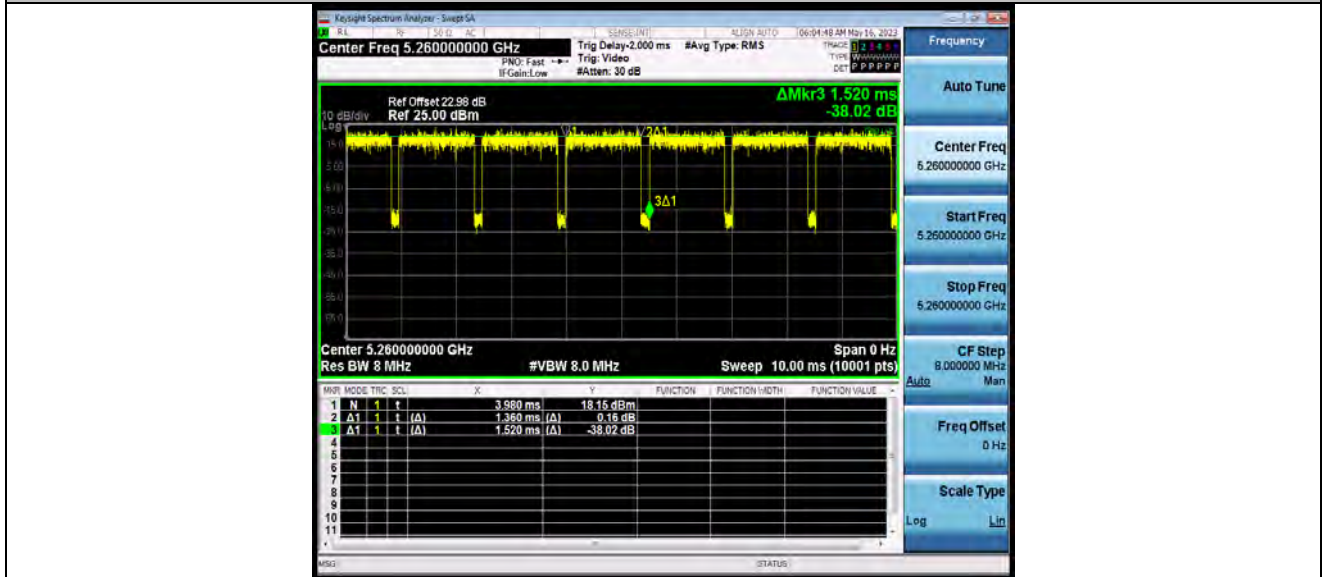

11A_Ant1_5300



BUREAU VERITAS

Test Report No.: W7L-P23050004-1RF03

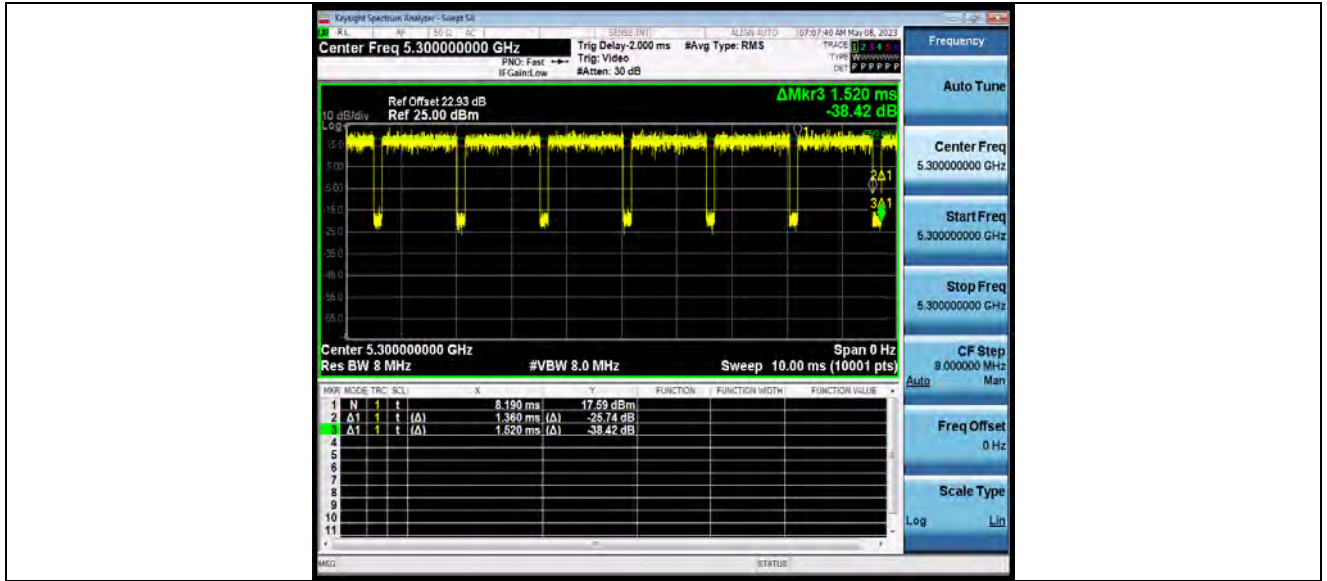

11A_Ant1_5320

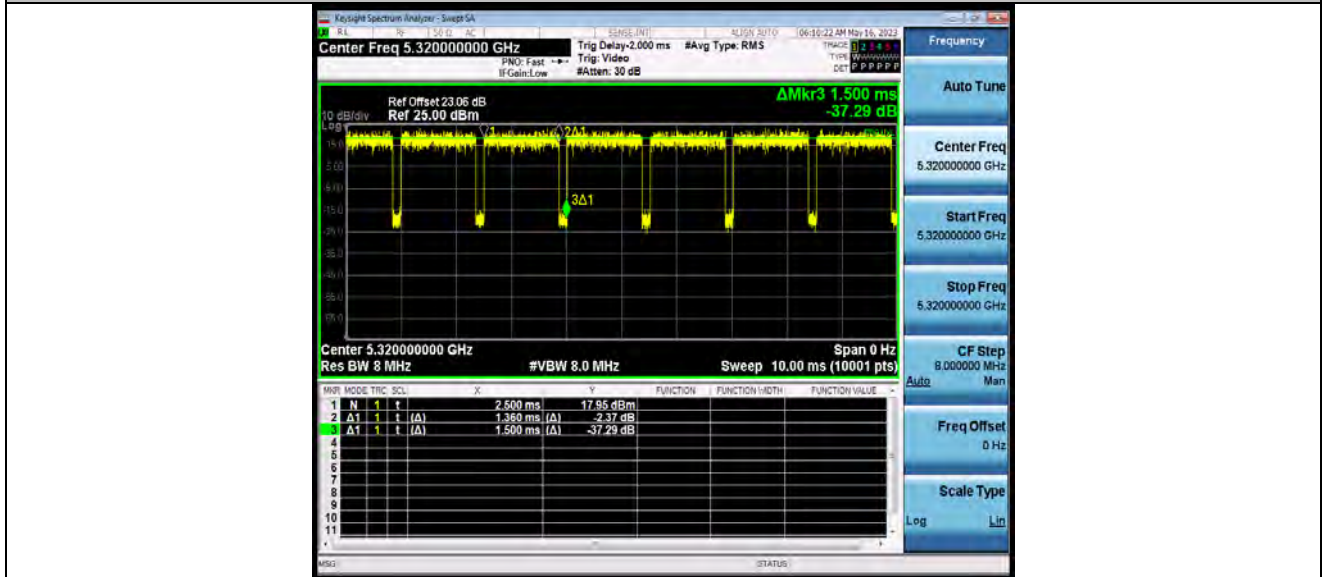

11A_Ant1_5500



BUREAU VERITAS

Test Report No.: W7L-P23050004-1RF03

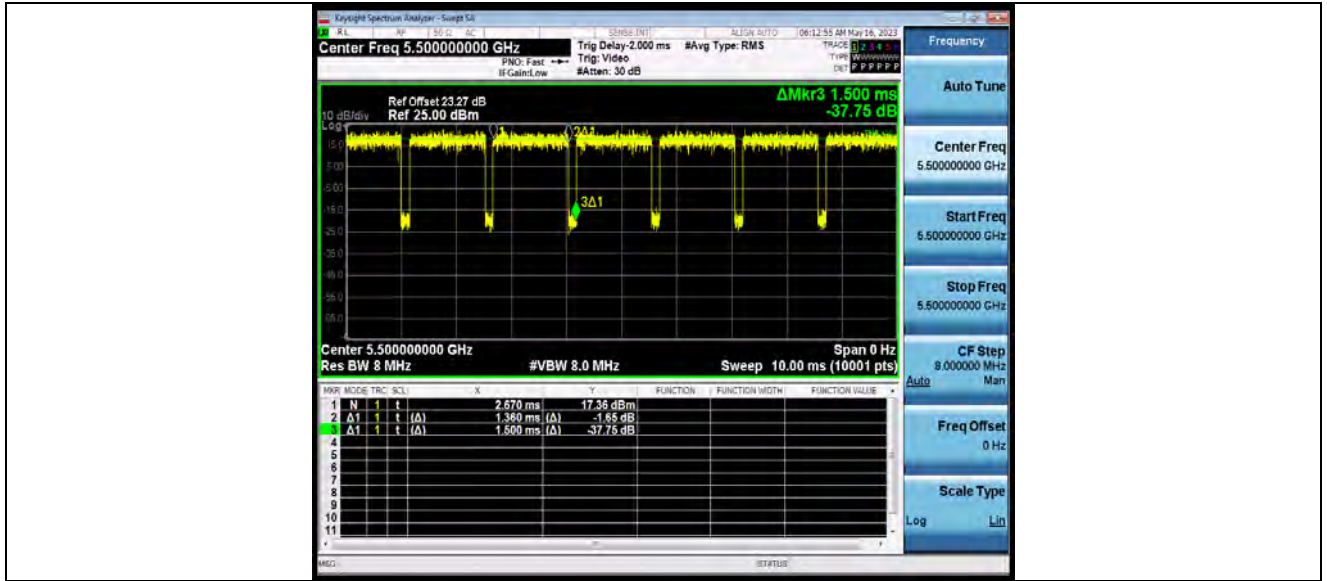

11A_Ant1_5580

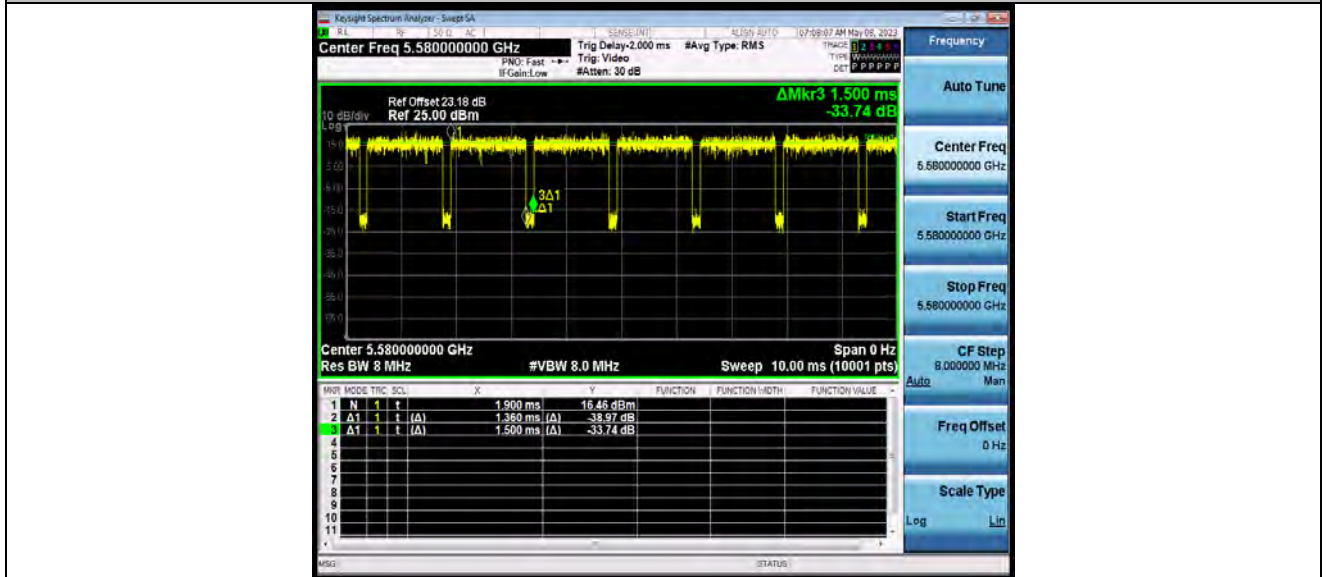

11A_Ant1_5700



BUREAU VERITAS

Test Report No.: W7L-P23050004-1RF03

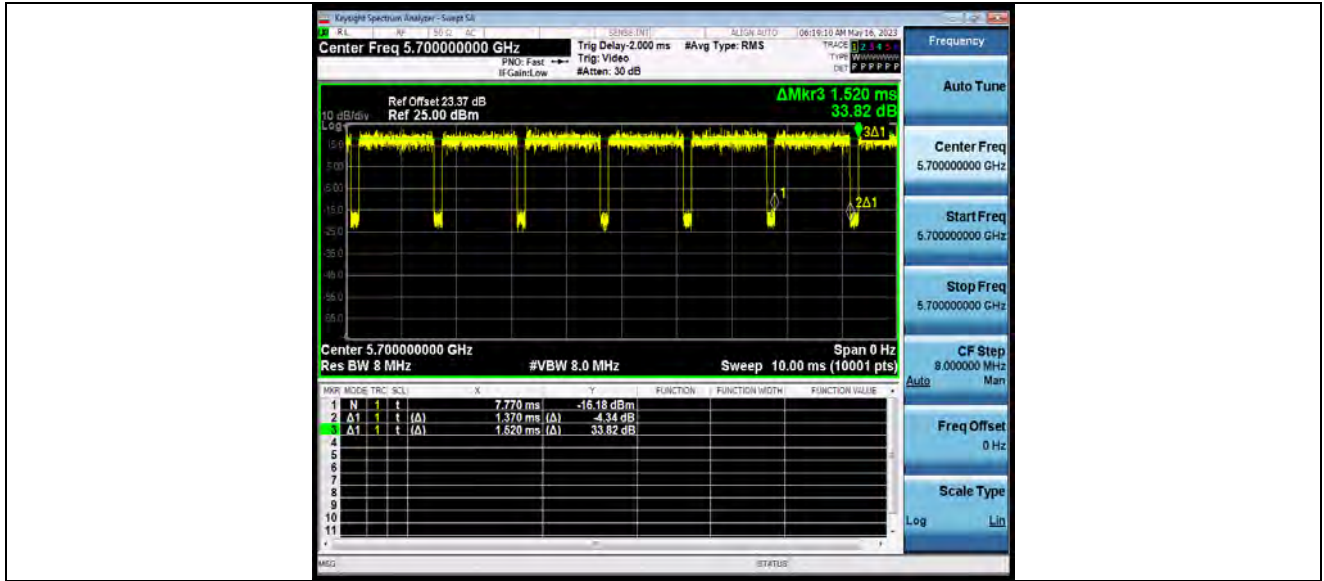

11A_Ant1_5745

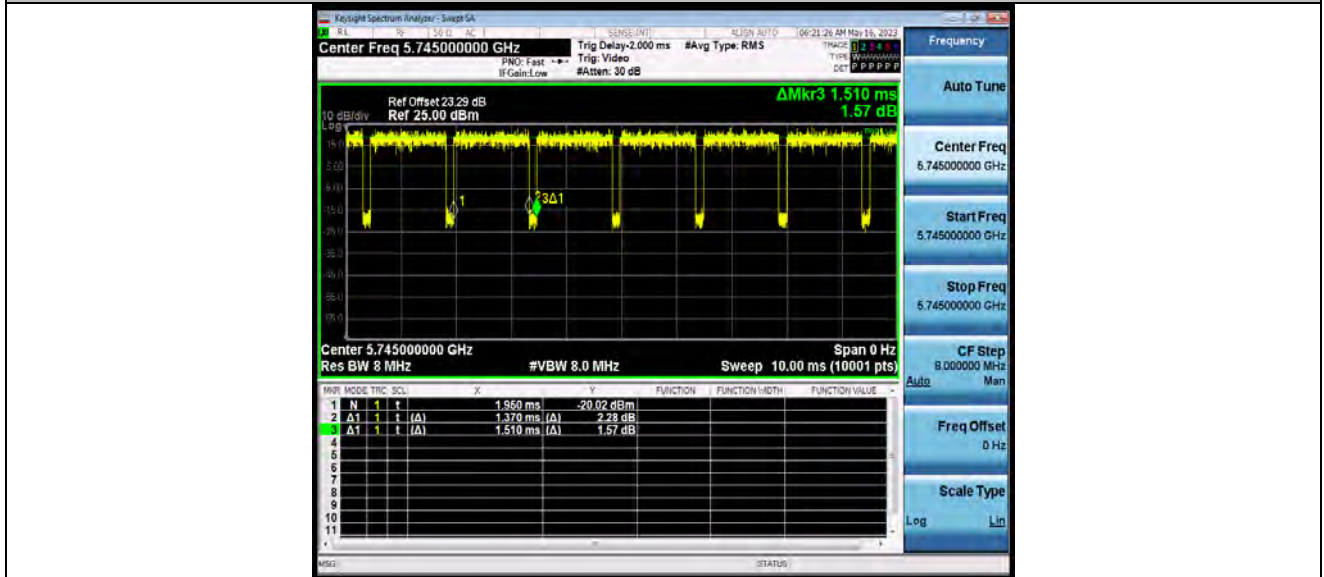

11A_Ant1_5785



**BUREAU
VERITAS**

Test Report No.: W7L-P23050004-1RF03

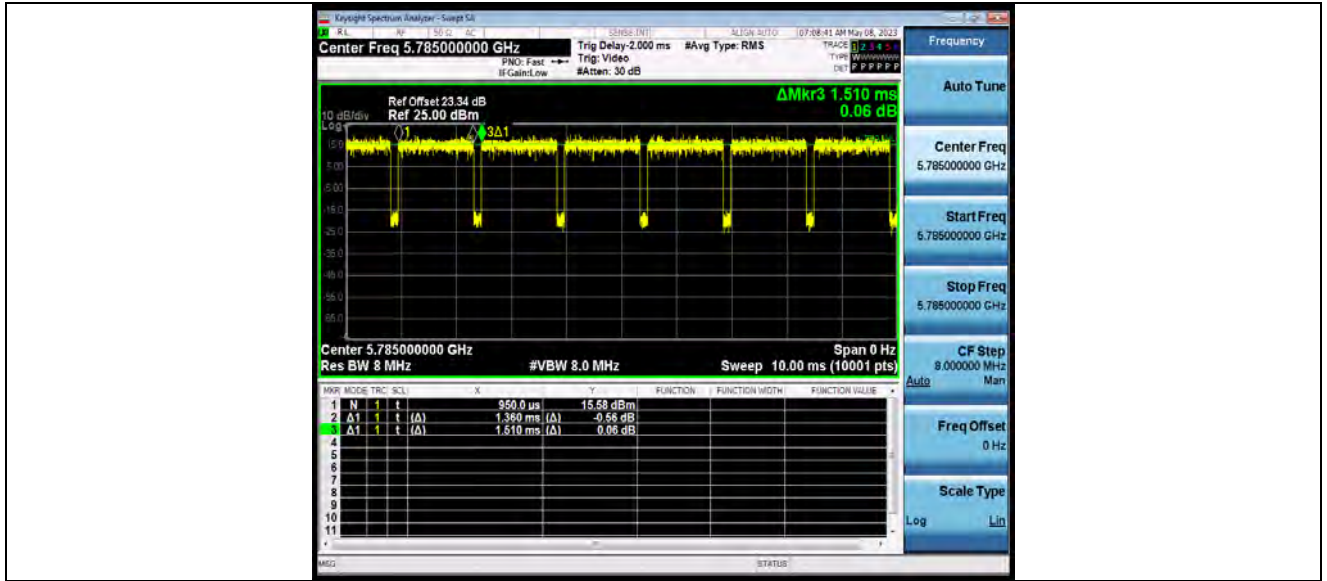

11A_Ant1_5825

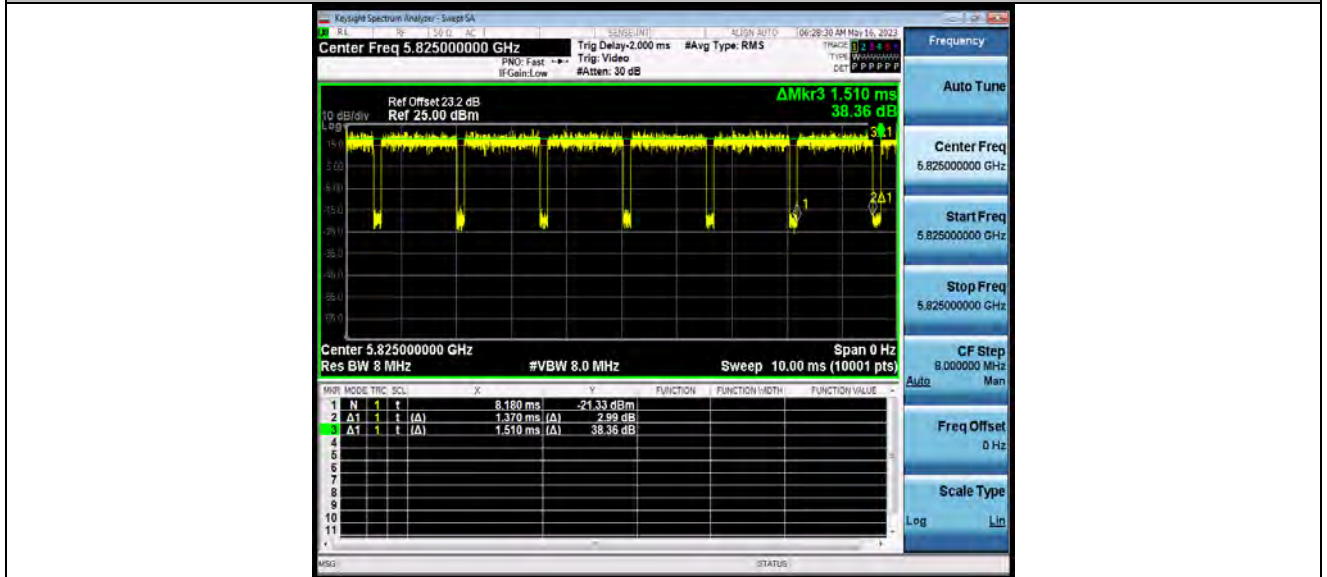

11N20SISO_Ant1_5180



**BUREAU
VERITAS**

Test Report No.: W7L-P23050004-1RF03

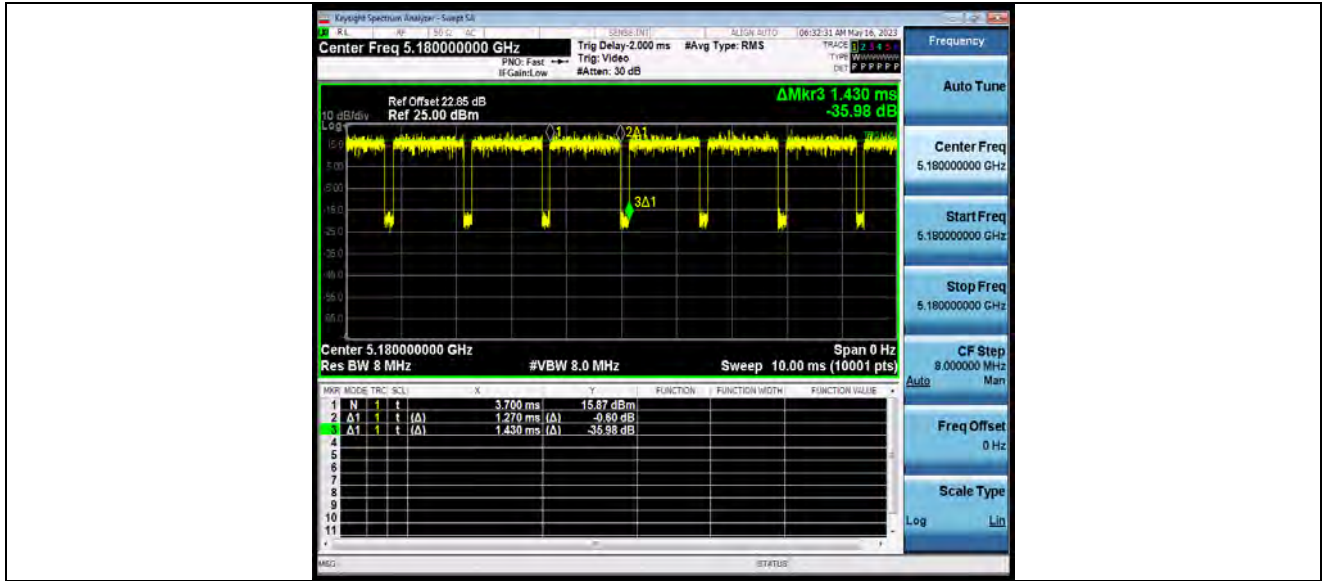

11N20SISO_Ant1_5200

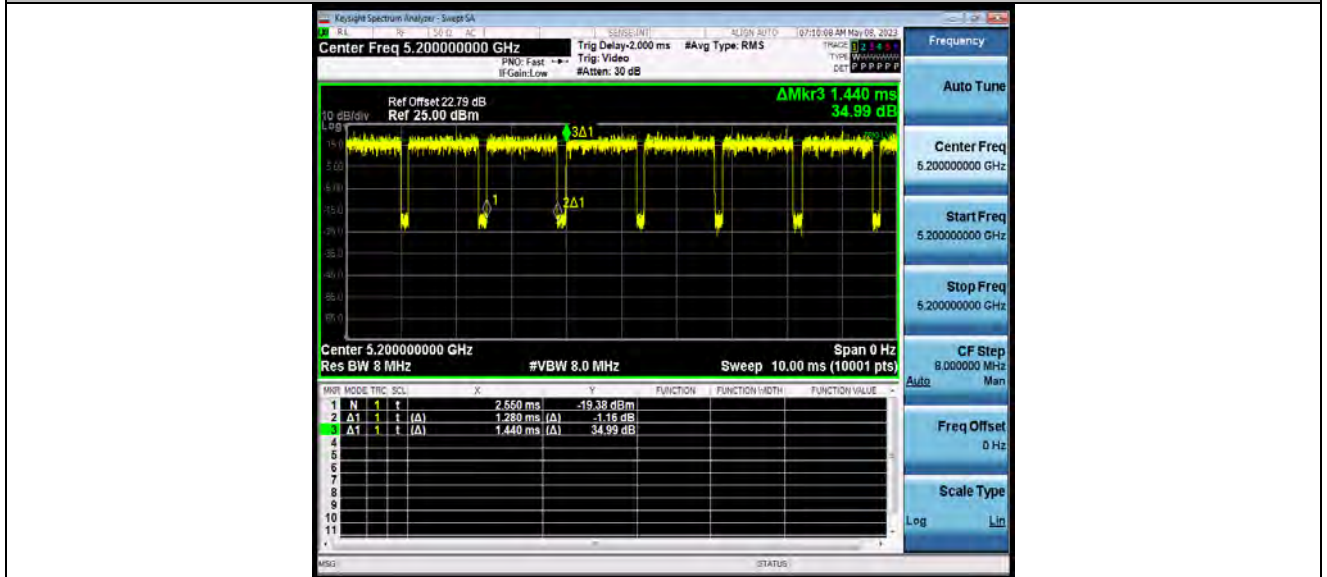

11N20SISO_Ant1_5240



**BUREAU
VERITAS**

Test Report No.: W7L-P23050004-1RF03

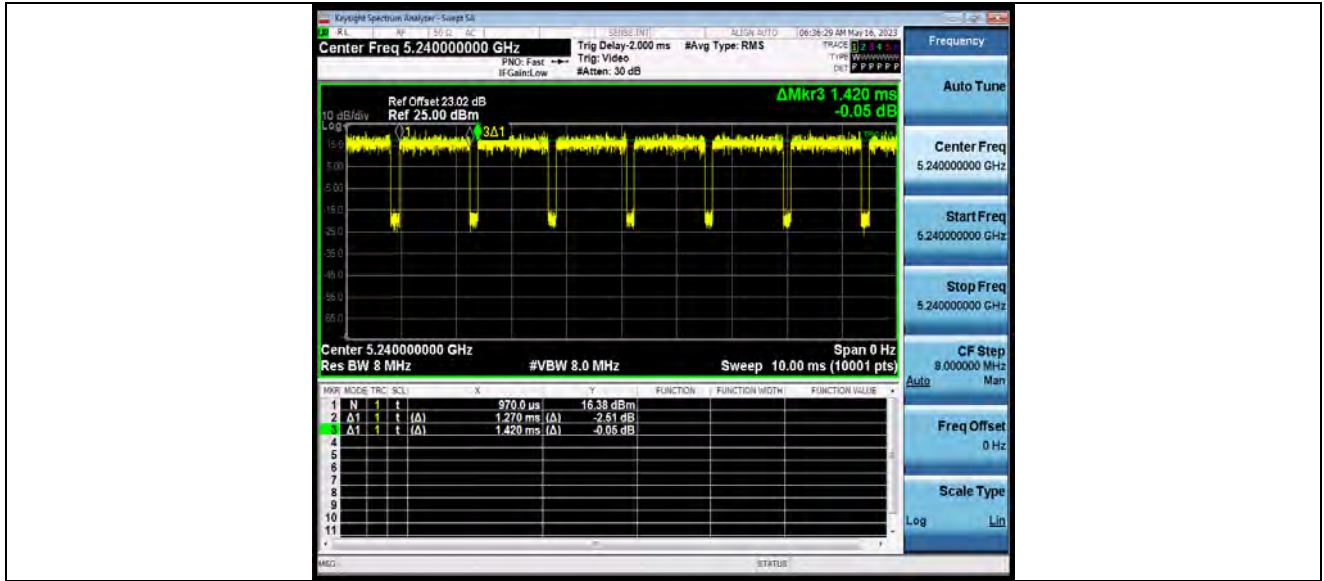

11N20SISO_Ant1_5260

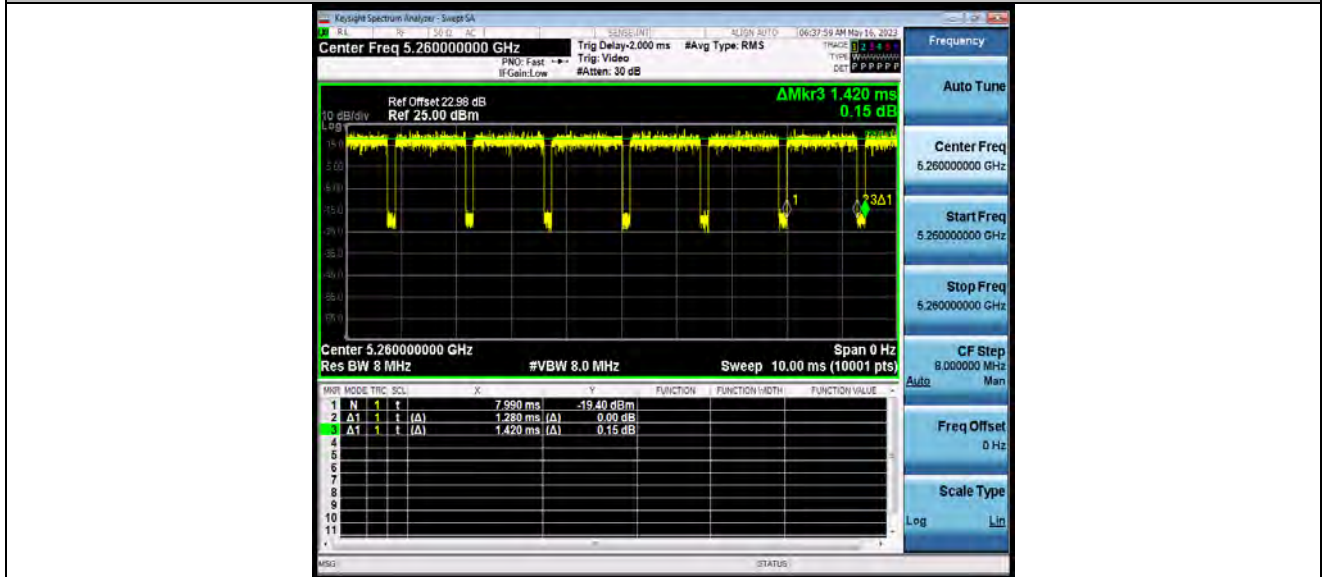

11N20SISO_Ant1_5300



BUREAU VERITAS

Test Report No.: W7L-P23050004-1RF03

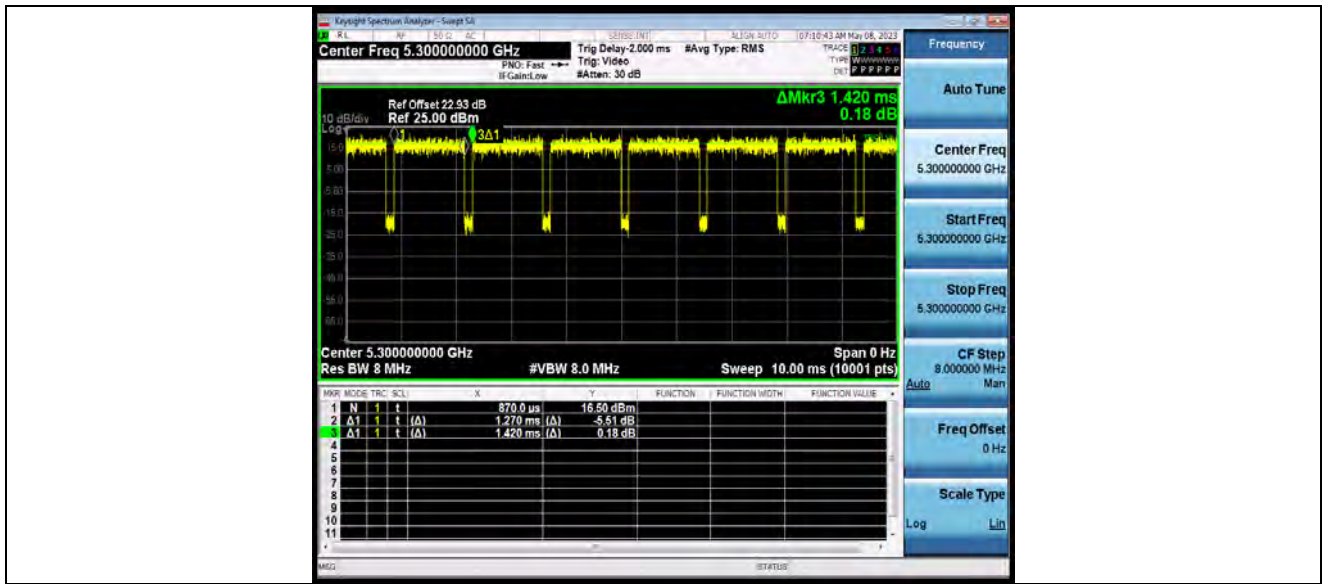

11N20SISO_Ant1_5320

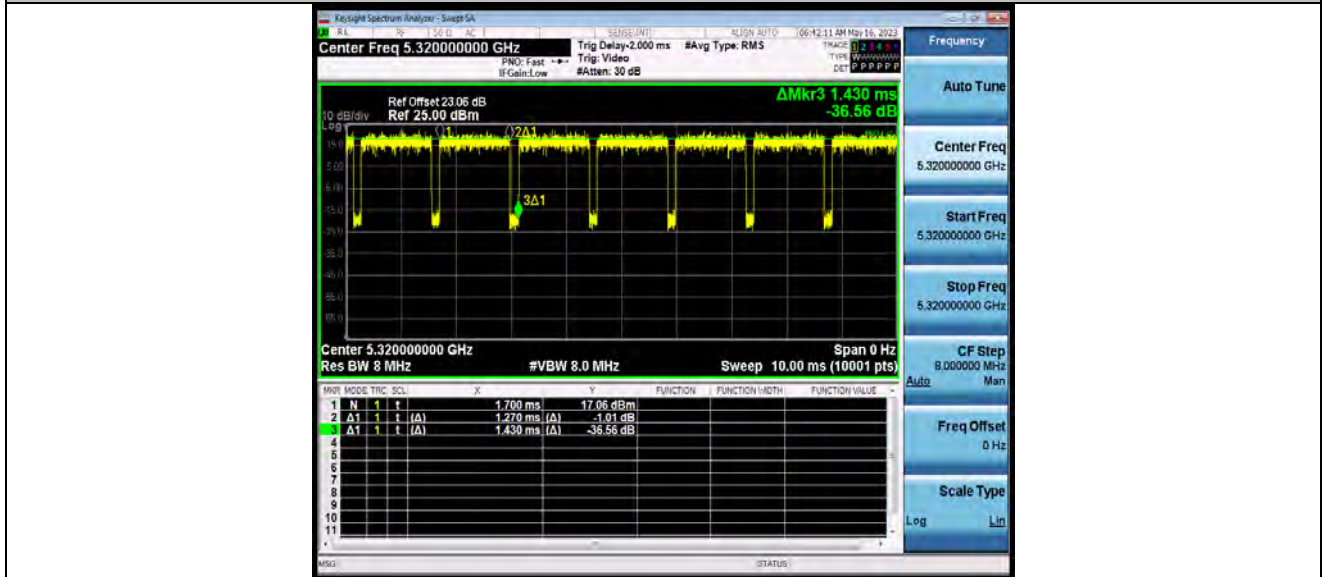

11N20SISO_Ant1_5500



BUREAU VERITAS

Test Report No.: W7L-P23050004-1RF03

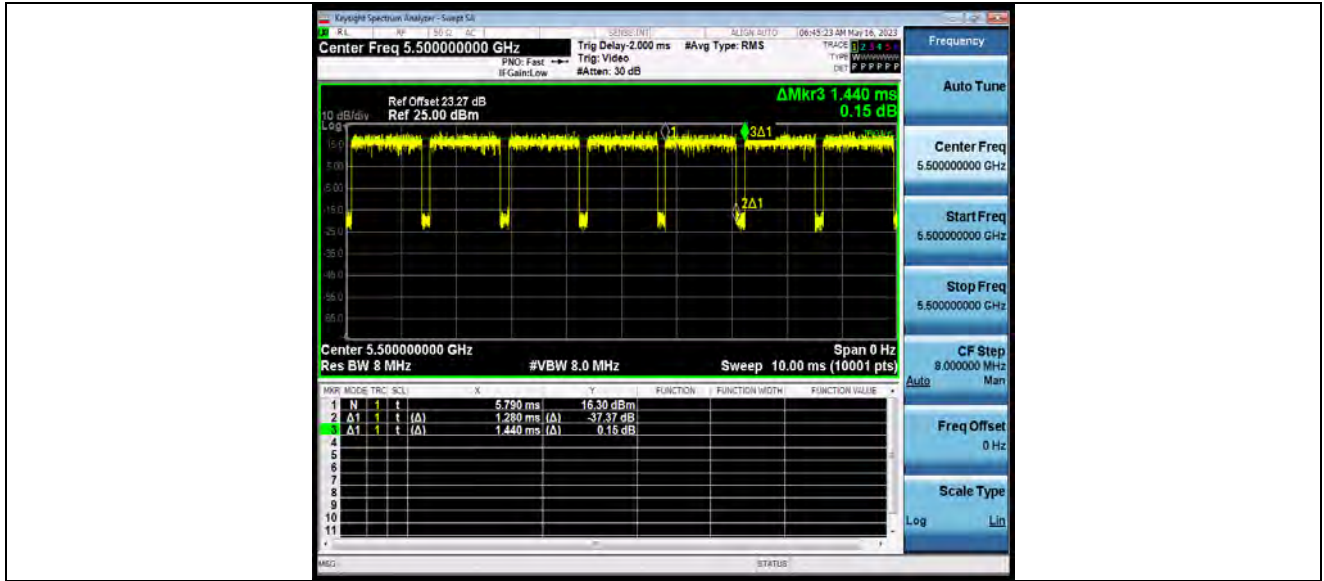

11N20SISO_Ant1_5580

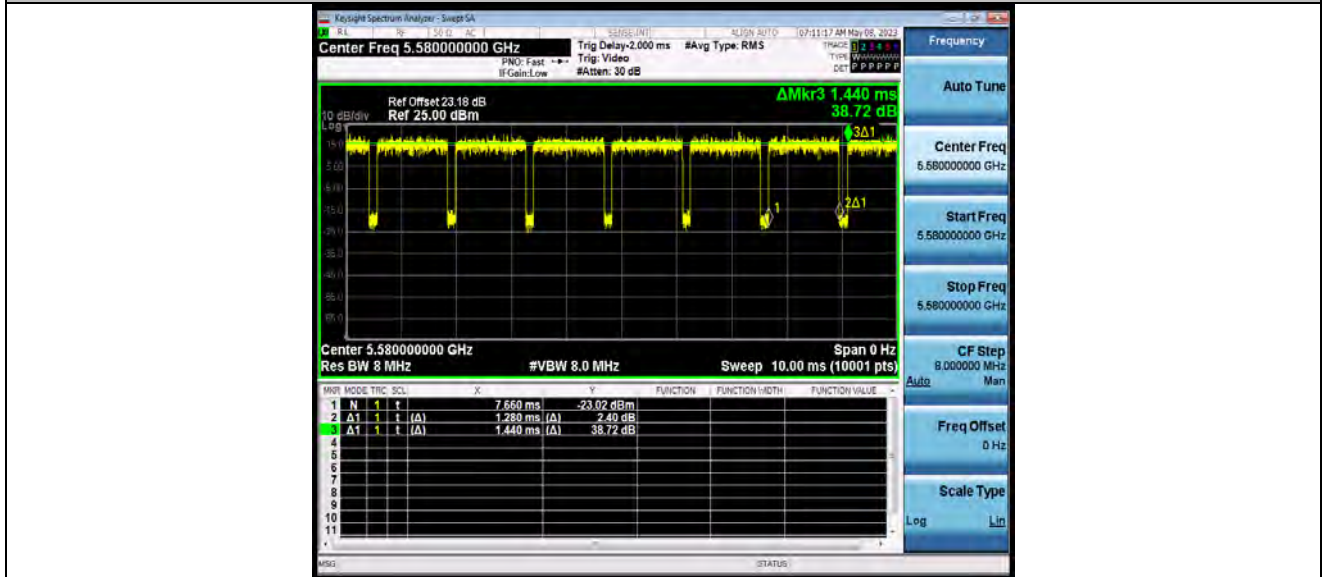

11N20SISO_Ant1_5700



BUREAU VERITAS

Test Report No.: W7L-P23050004-1RF03

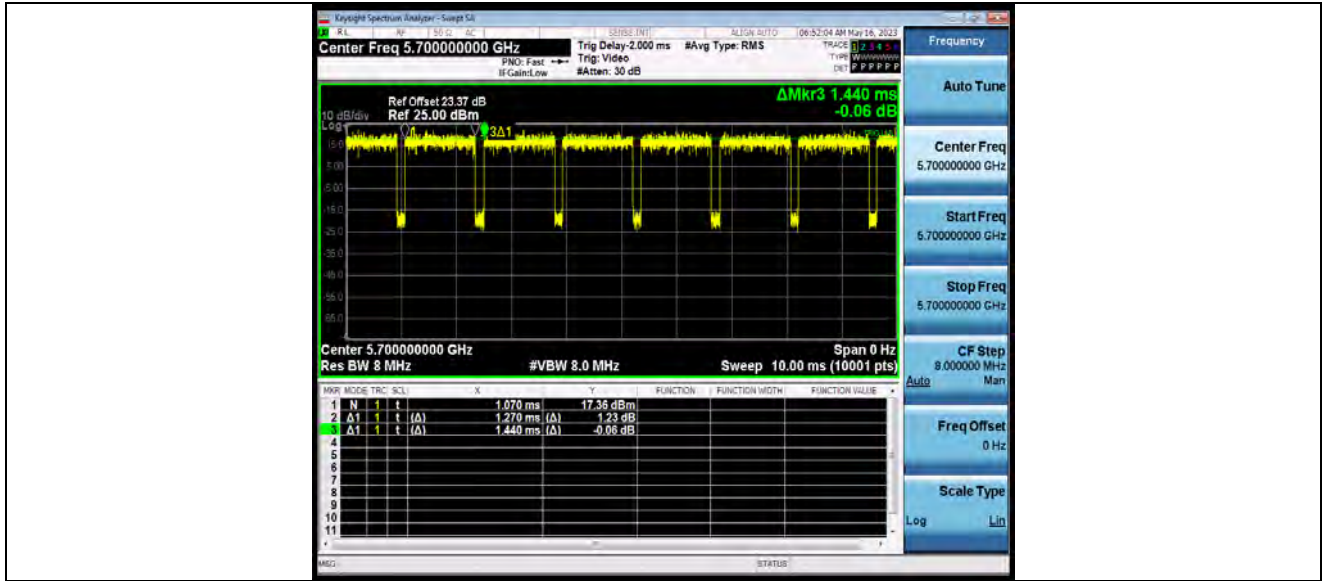

11N20SISO_Ant1_5745

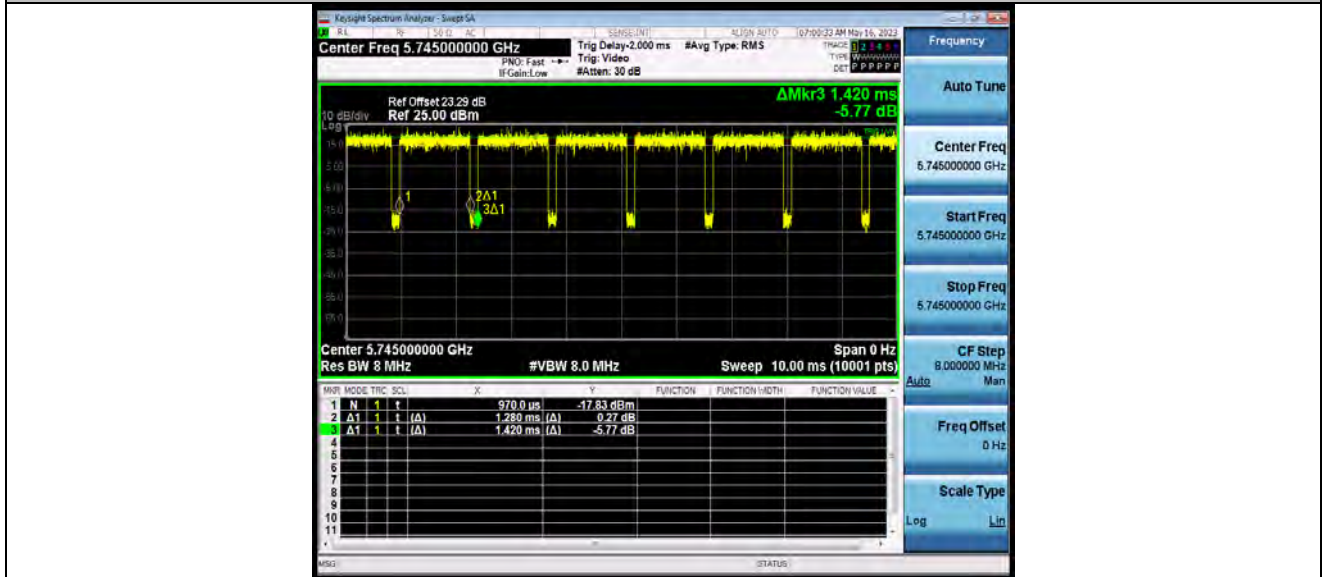

11N20SISO_Ant1_5785



**BUREAU
VERITAS**

Test Report No.: W7L-P23050004-1RF03

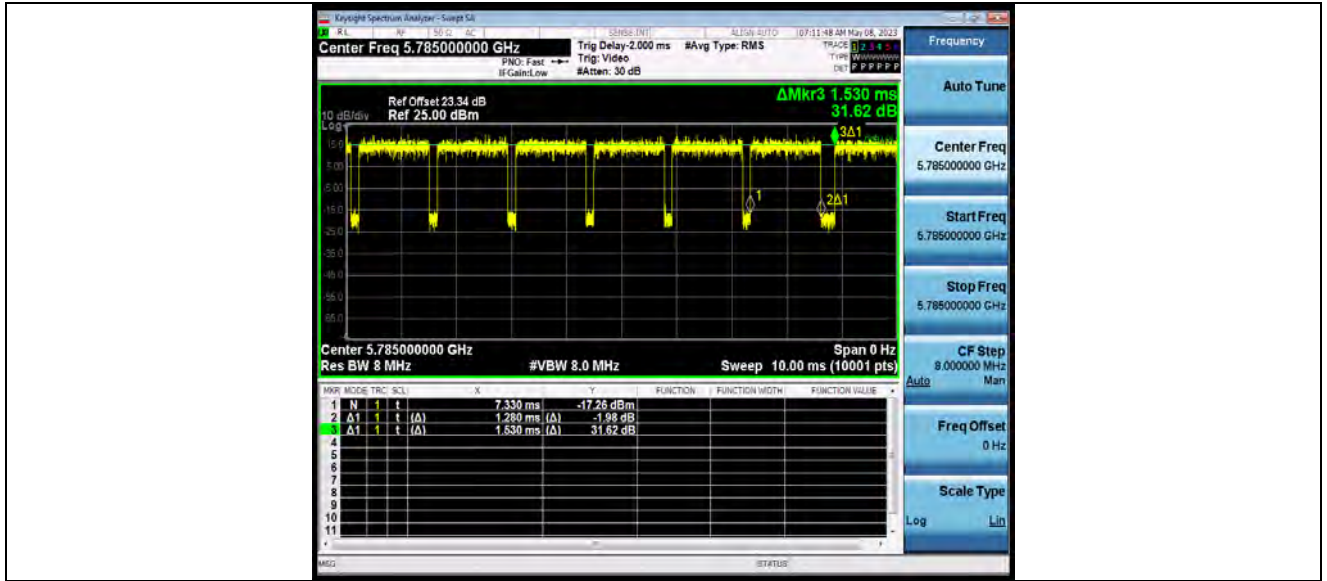

11N20SISO_Ant1_5825

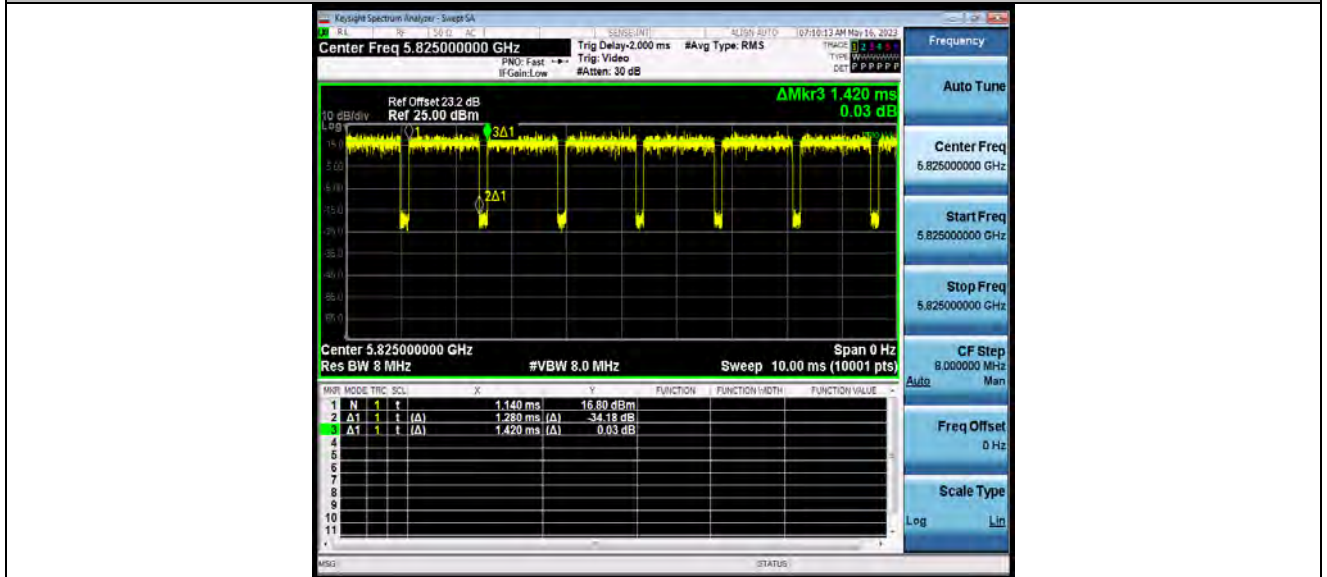

11N40SISO_Ant1_5190



BUREAU VERITAS

Test Report No.: W7L-P23050004-1RF03

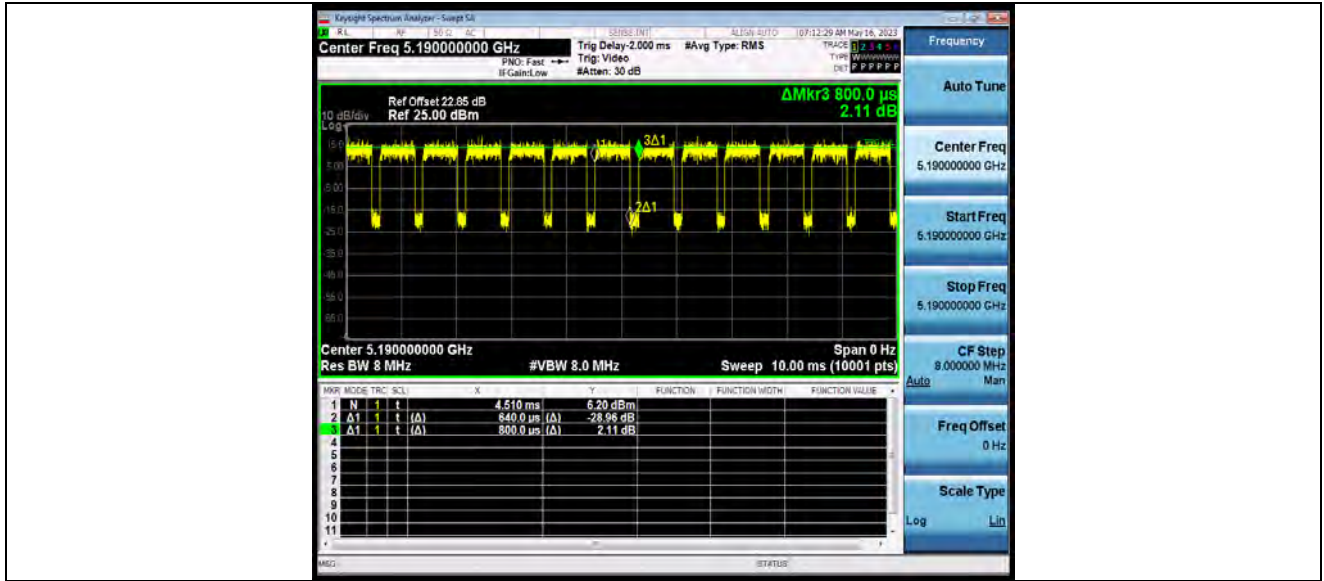

11N40SISO_Ant1_5230

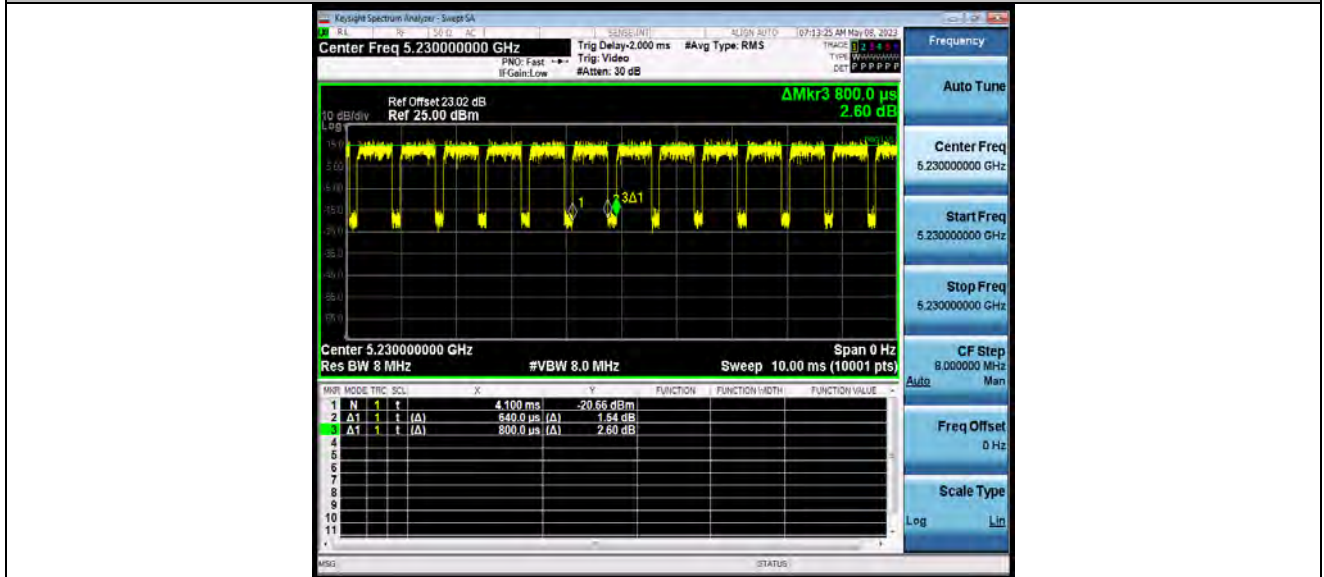

11N40SISO_Ant1_5270



BUREAU VERITAS

Test Report No.: W7L-P23050004-1RF03

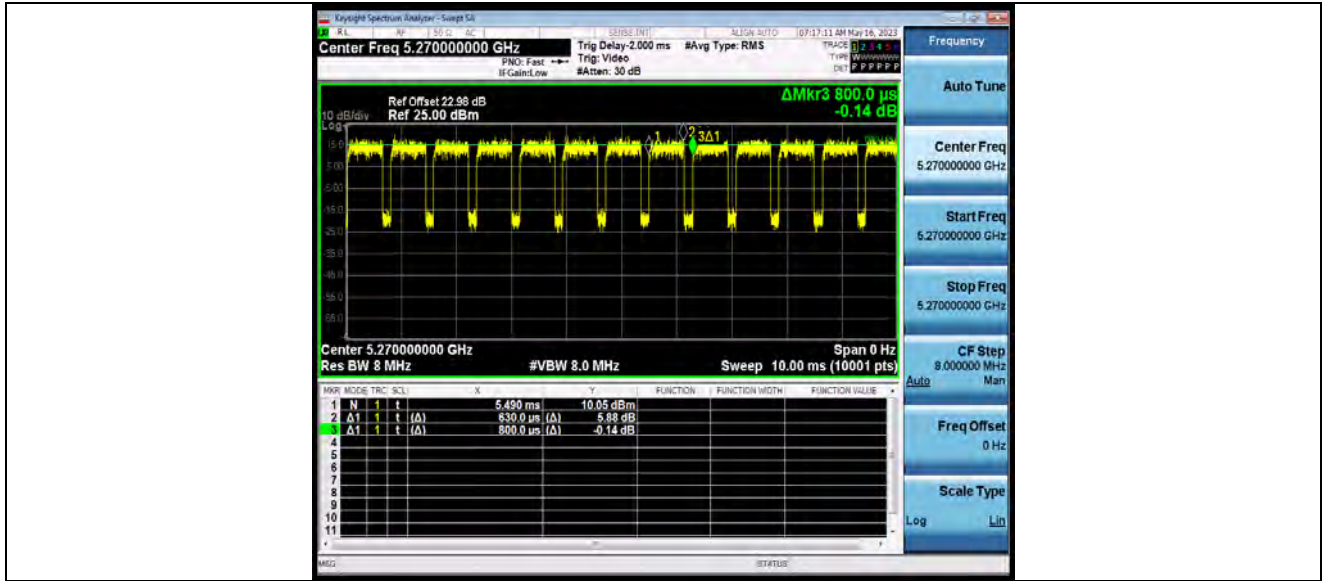

11N40SISO_Ant1_5310

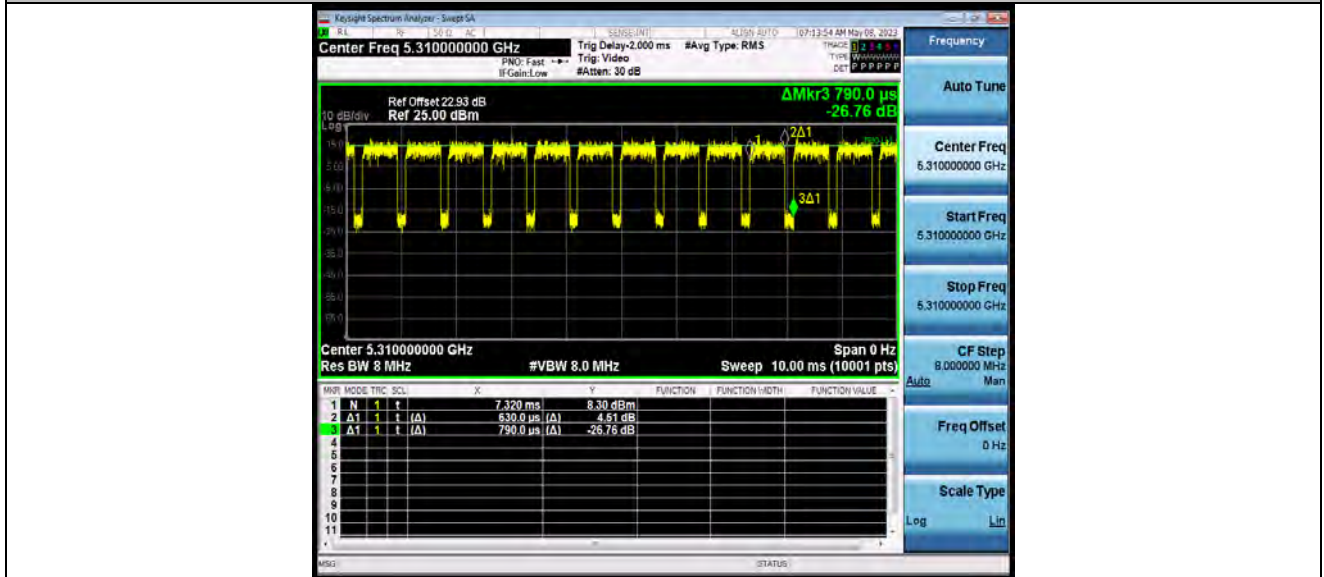

11N40SISO_Ant1_5510



BUREAU VERITAS

Test Report No.: W7L-P23050004-1RF03

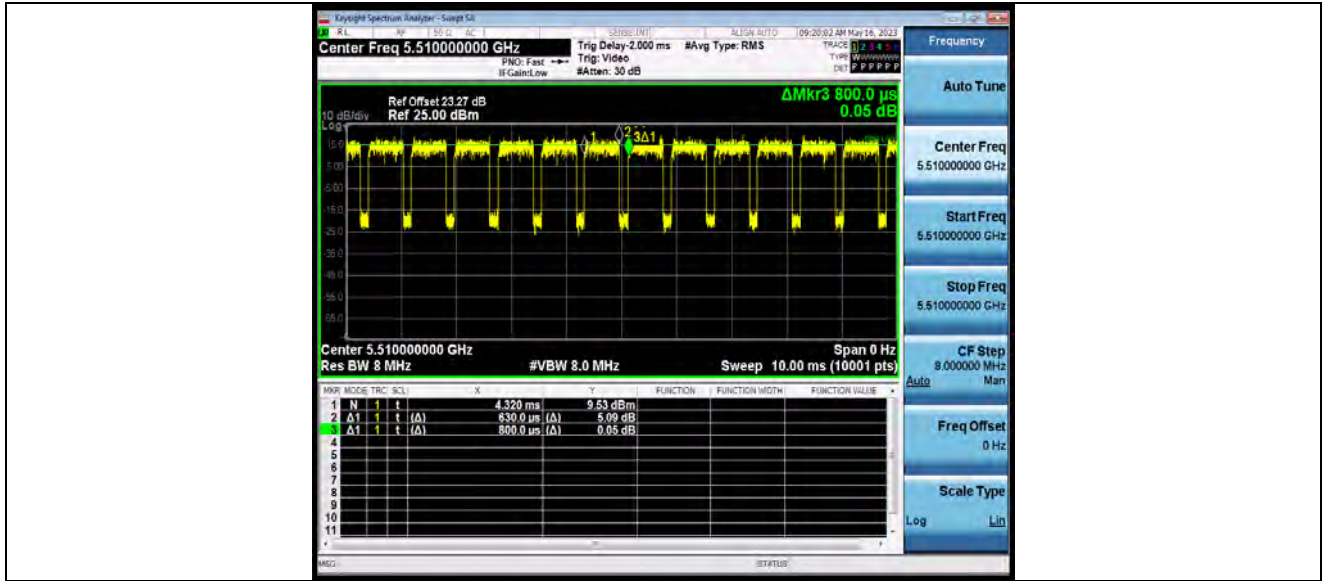

11N40SISO_Ant1_5550

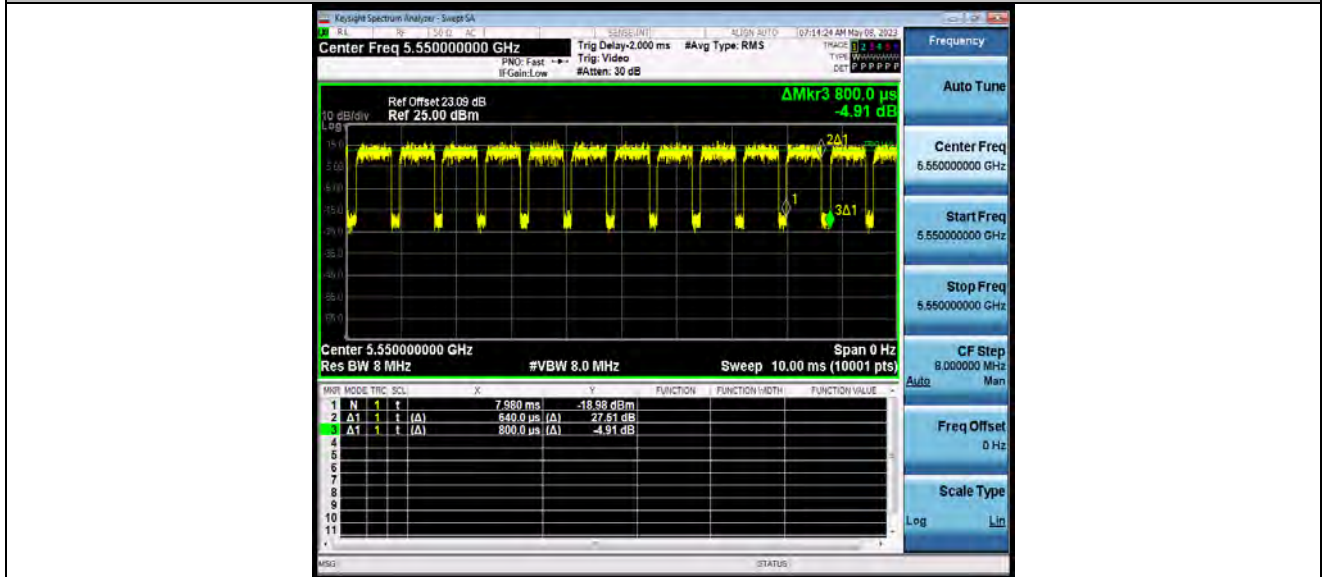

11N40SISO_Ant1_5670



BUREAU VERITAS

Test Report No.: W7L-P23050004-1RF03

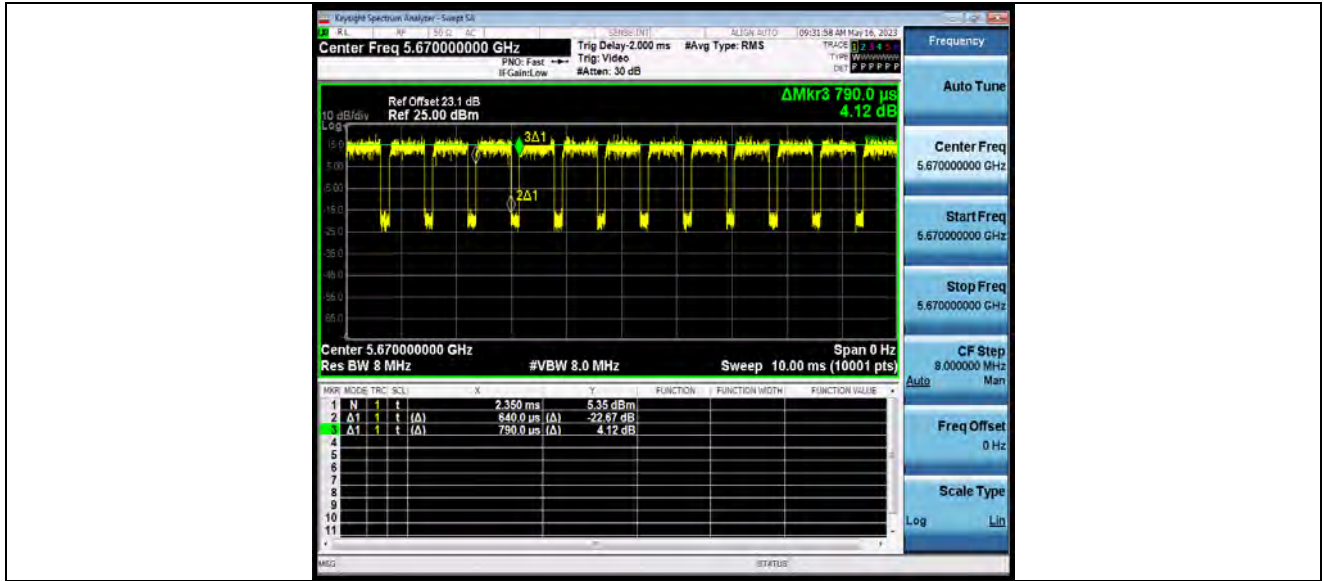

11N40SISO_Ant1_5755

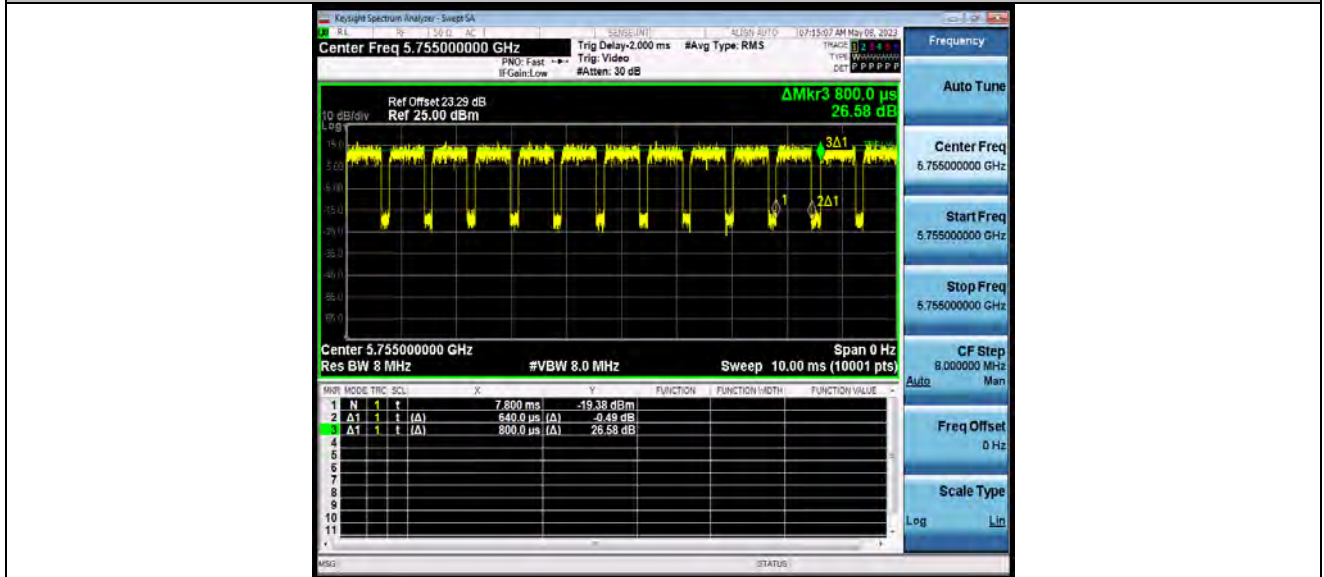

11N40SISO_Ant1_5795



BUREAU VERITAS

Test Report No.: W7L-P23050004-1RF03

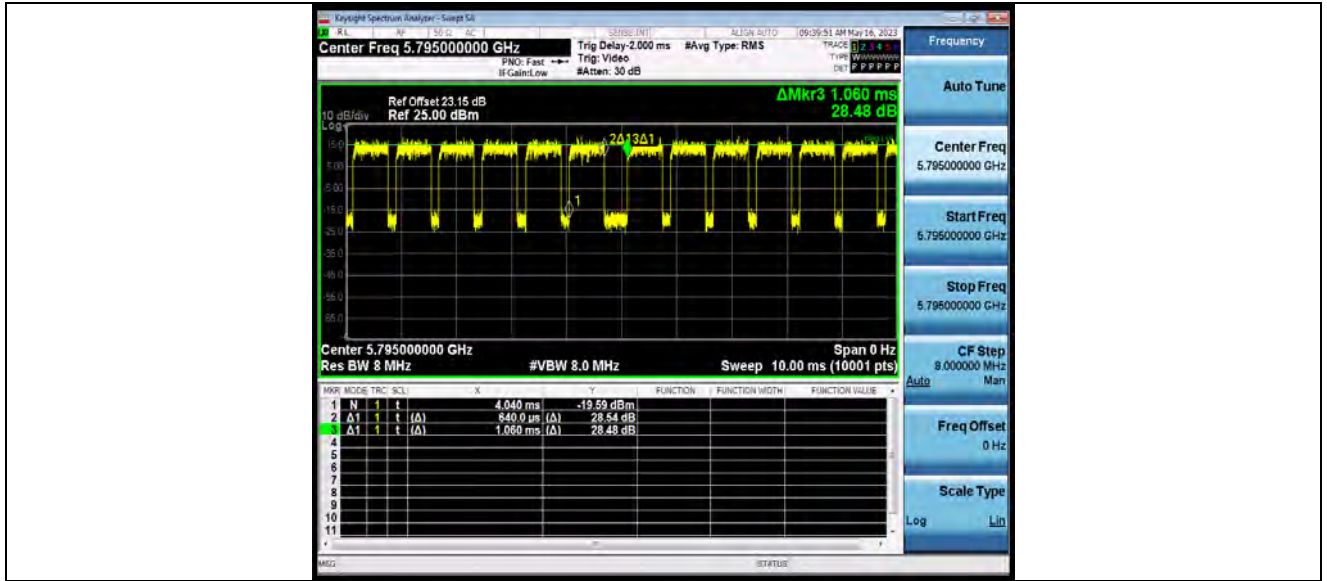

11AC20SISO_Ant1_5180

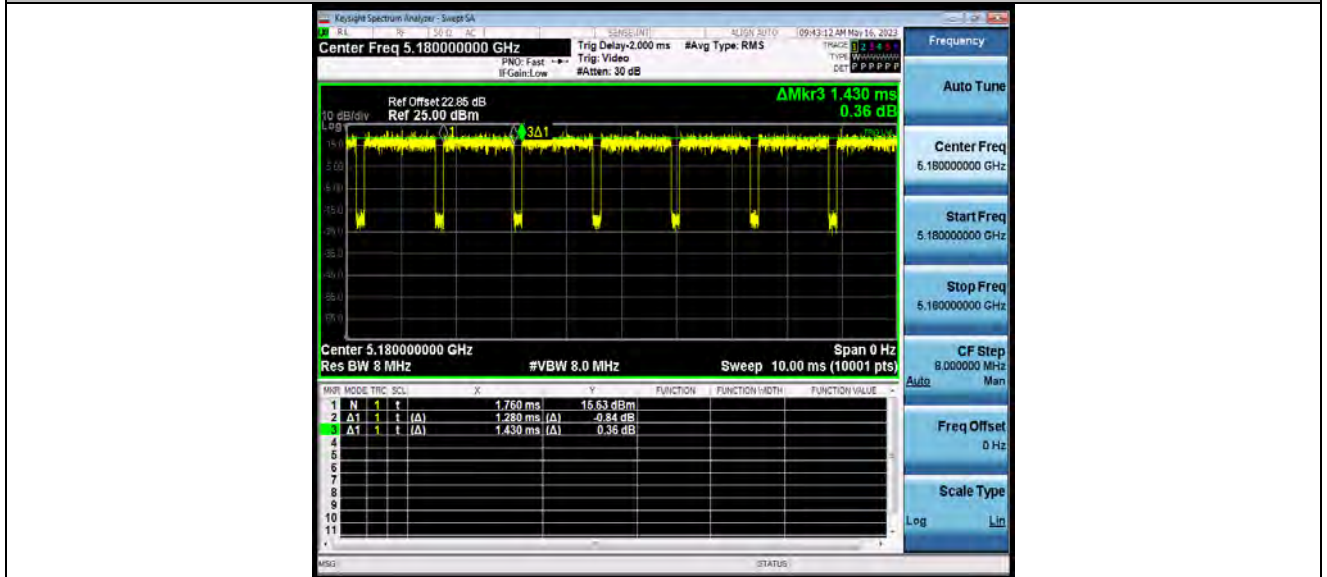

11AC20SISO_Ant1_5200



**BUREAU
VERITAS**

Test Report No.: W7L-P23050004-1RF03

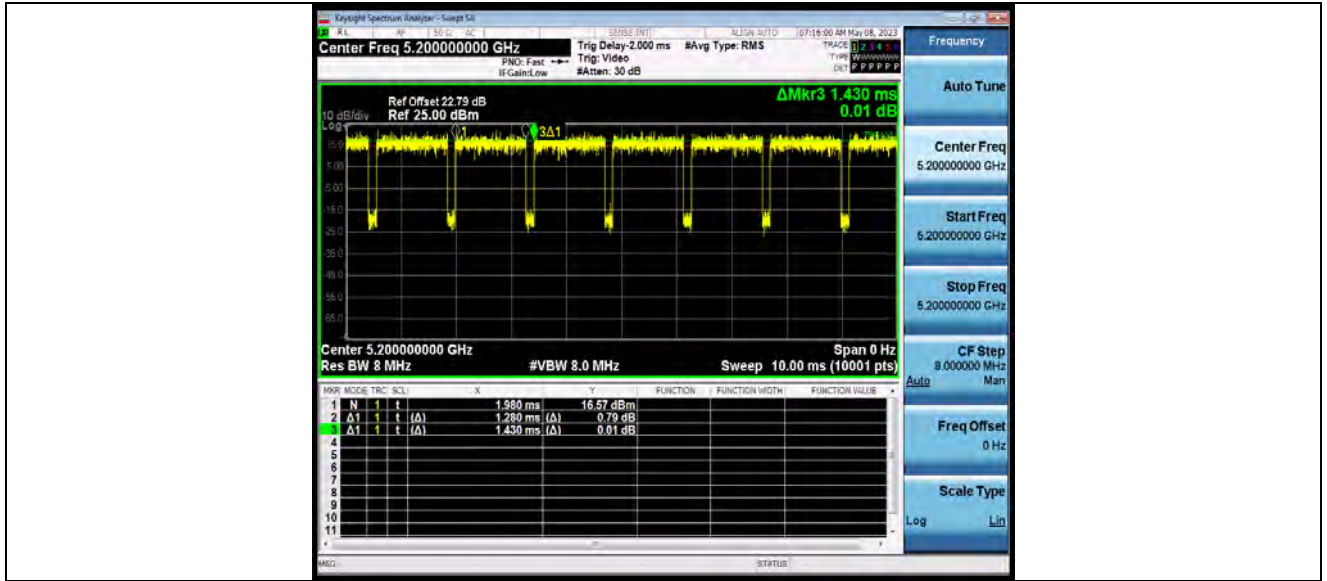

11AC20SISO_Ant1_5240

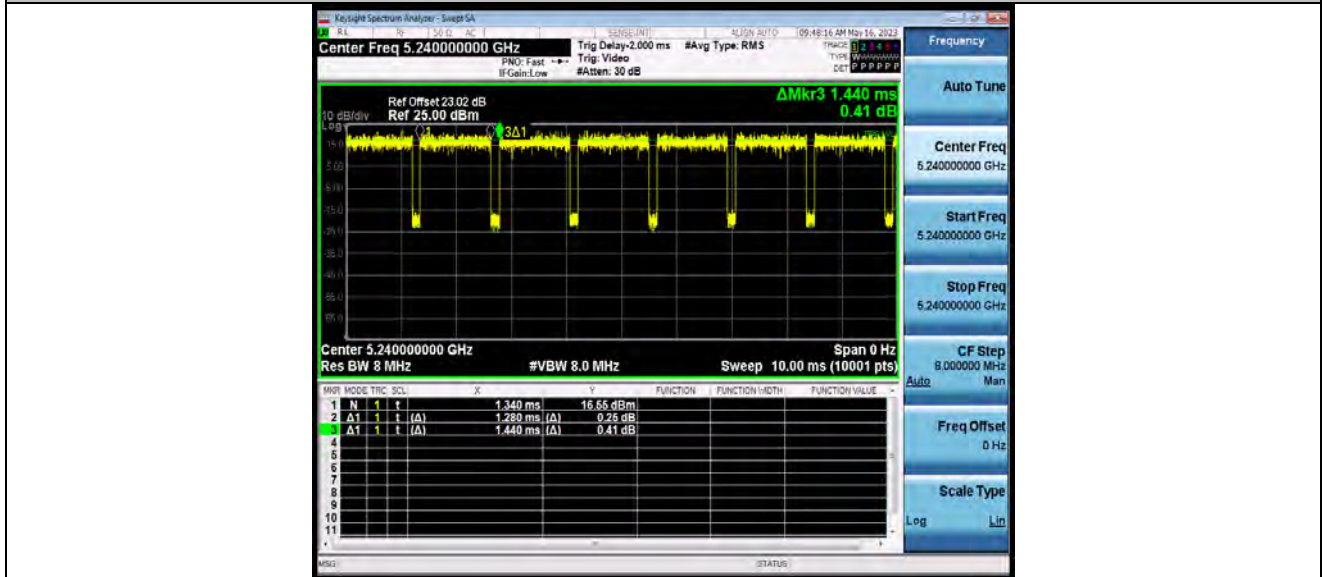

11AC20SISO_Ant1_5260

