



# ACR1251U-C User Manual

ACR1251U-C User Manual V1.00

	<b>Name</b>	<b>Signature</b>	<b>Date</b>
<b>Prepared by:</b>	Kit Au		2013-03-27
<b>Reviewed by:</b>			
<b>Approved by:</b>			



## Version History

Date	By	Changes	Version
2013-06-26	Kit Au	<ul style="list-style-type: none"><li>• First Release</li><li>•</li></ul>	1.00.00



## Table of Contents

<b>1.0.</b>	<b>Introduction .....</b>	<b>4</b>
<b>2.0.</b>	<b>Features .....</b>	<b>5</b>
<b>3.0.</b>	<b>Architecture .....</b>	<b>5</b>
<b>4.0.</b>	<b>ACR1251U-C Operating Procedure .....</b>	<b>7</b>
4.1.	Driver installation Procedure.....	7
4.2.	Operation Example .....	10
<b>Appendix A.</b>	<b>Parameter sheet.....</b>	<b>12</b>



## **1.0. Introduction**

The ACR1251U-C is a dual-interface reader (IFD and PCD) that supports contact (ICC), sim size contact (SAM) and contactless (PICC) smart cards.



## 2.0. Features

- One standard ICC landing type card acceptor.
- One SAM socket
- ISO 7816 Parts 1-4 Compliant for Contact Smart Card Interface.
- The ACR1251U-C supports contact memory cards (refer to appendix D).
- ISO 14443 Parts 1-4 Compliant for Contactless Smart Card Interface.
- A built-in antenna for PICC contactless access applications.
- The ACR1251U-C supports the following Tag Types:
  - MIFARE Classic. E.g. MIFARE 1K, 4K, MINI and Ultralight.
  - ISO14443-4 Type A and B.
  - ISO18092 FeliCa, NFC tag
- T=CL emulation for MIFare 1K/4K PICCs
- High Speed (424 kbps) Communication for PICCs. #Maximum 848 kbps.
- Energy saving modes for turning off the antenna field whenever the PICC is inactive, or no PICC is found. It prevents the PICC from exposing to the field all the time.
- User-Controllable Peripherals. E.g. LED, Buzzer.
- PCSC Compliant for Contact and Contactless Interfaces.
- USB V2.0 Interface. (12M bps)
- Device Firmware Upgradeable through the USB Interface.

### 3.0. Architecture

AT90SCR is for main processor for communication with PC, and control the contactless chip, communication with ICC contact card and peripherals. PN512 act as a contactless chip to perform the communication between contactless tags and AT90SCR

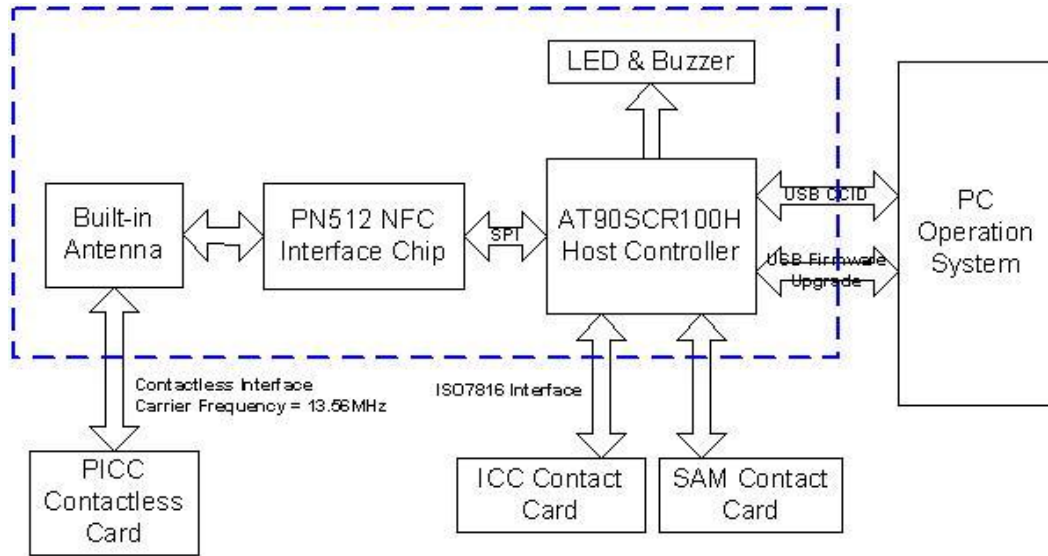

For communication architecture, the protocol between ACR1251U-C and PC is using CCID protocol. All the communication between ICC and PICC are PCSC Compliant

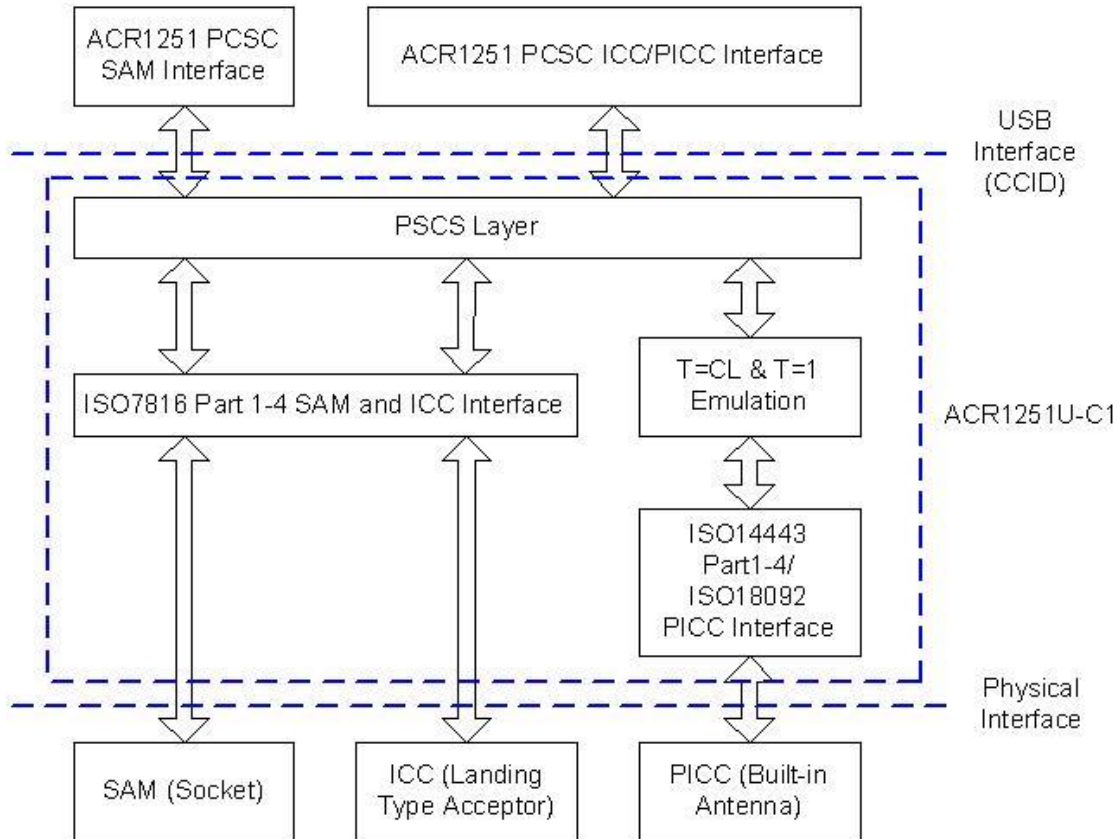

**PICC and ICC are working exclusively, when ICC inserted, PICC will be disabled.**

## 4.0.ACR1251U-C Operating Procedure

### 4.1. Driver installation Procedure

Hardware requires:

- ❖ ACR1251U-C
- ❖ PC with OS windows XP or above

Software requires:

- ❖ Driver “Microsoft CCID Driver Version 5.2.3790.2724.rar”

Steps:

1. Extract the file “Microsoft CCID Driver Version 5.2.3790.2724.rar”
2. Plug-in the ACR1251U-C1 to PC’s USB
3. Wait for driver install message



4. Select “Install from a list or specific location (Advanced)”, then “Next>”



5. Select "Don't search. I will choose the driver to install", then "Next>"

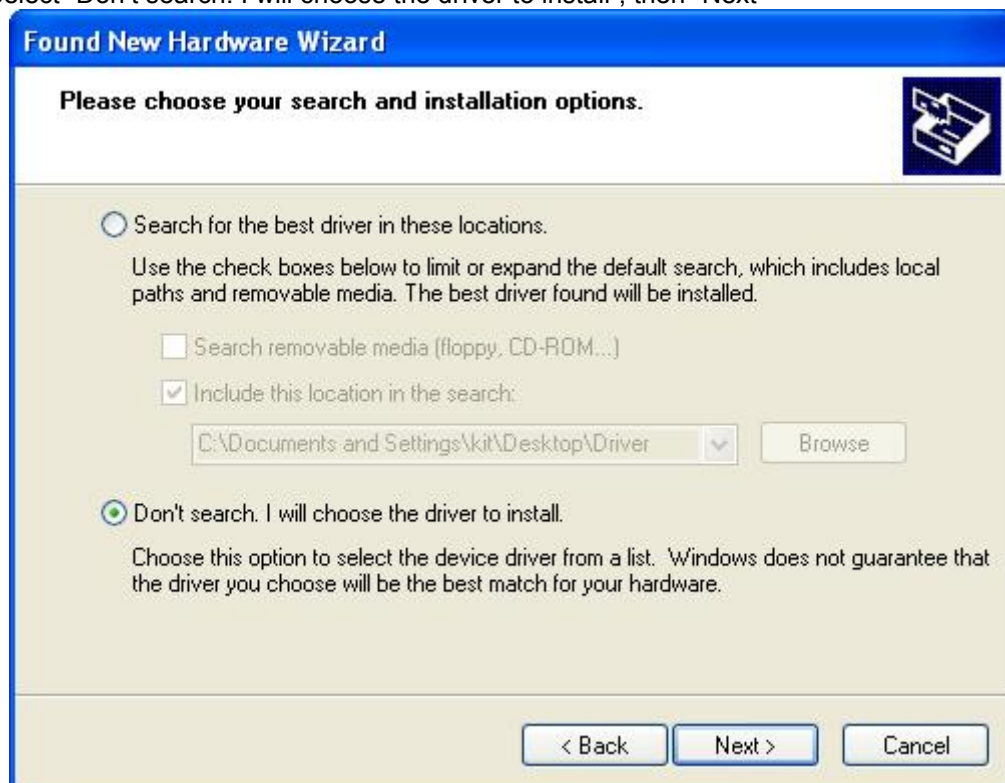

6. if present "USB Smart Card reader", select it and then "Next>"





if No, click “Have Disk...”

Click “Browse...” to locate the driver (usbccid.inf) location, click “Open”

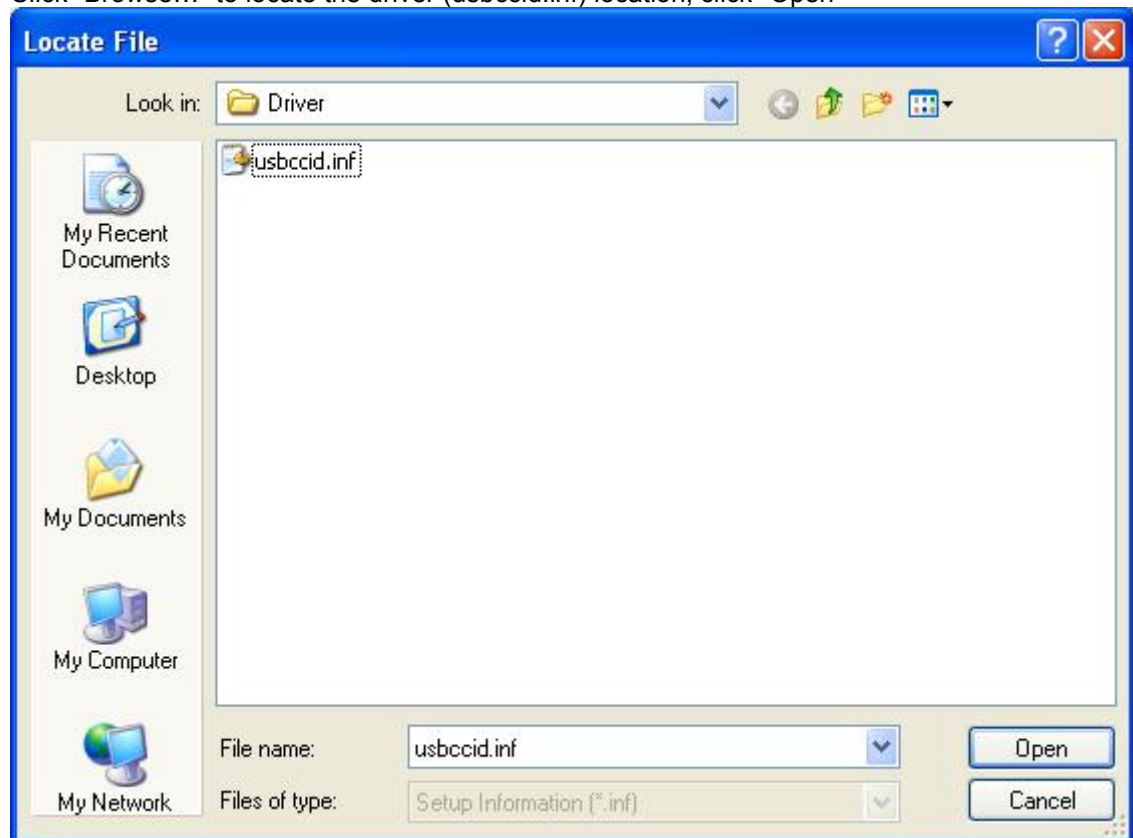

Select “USB Smart Card reader”, and then “Next>”

7. Click “Continue Anyway”



8. Wait until the below screen appear, click “Finish” to complete
9. Driver Installation Complete

## 4.2. Operation Example

Hardware requires:

- ❖ ACR1251U-C1 x 1
- ❖ PC with OS windows XP or above
- ❖ Test card x 1 (provided by ACS)

Software requires:

- ❖ APDU.exe (for example)

Steps:

1. Plug in the reader into the PC
2. Place the Card on the top of the reader
3. Open “APDU.exe”

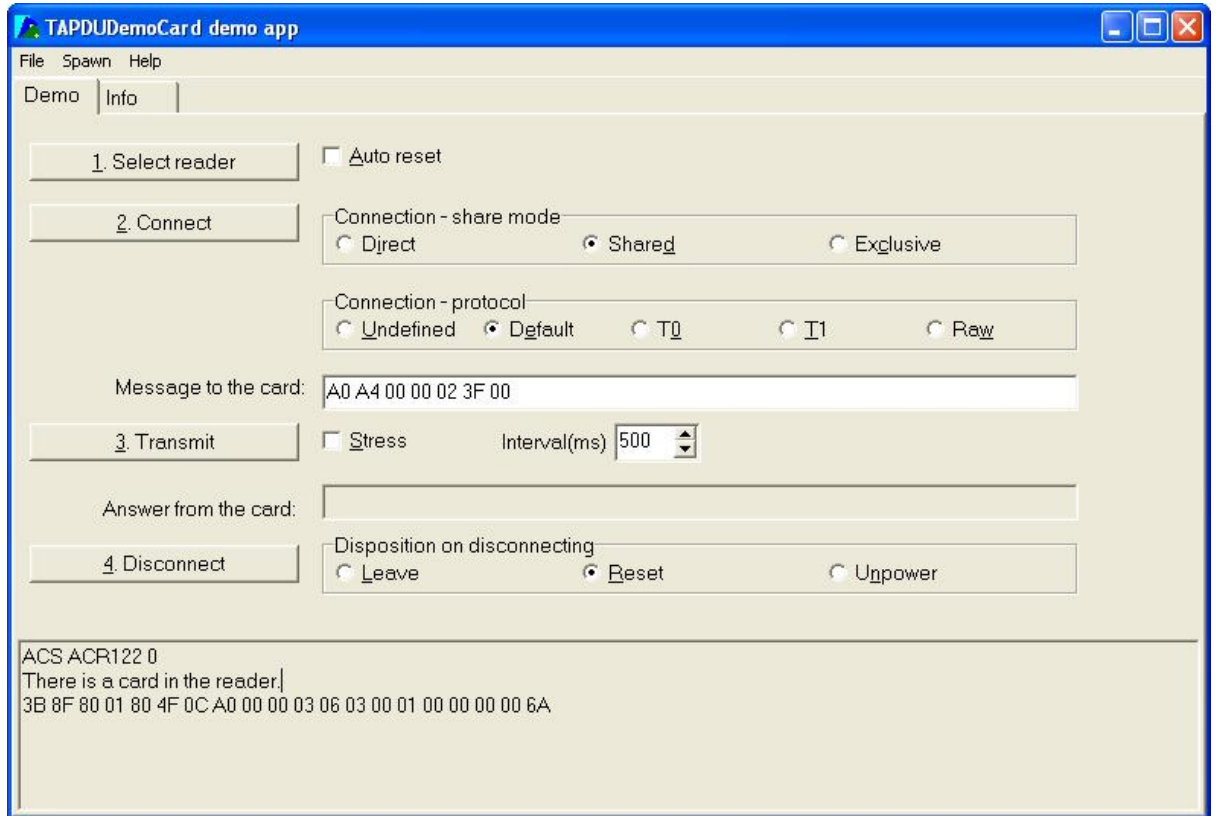

4. Select "T1", and enter the APDU into Message Field

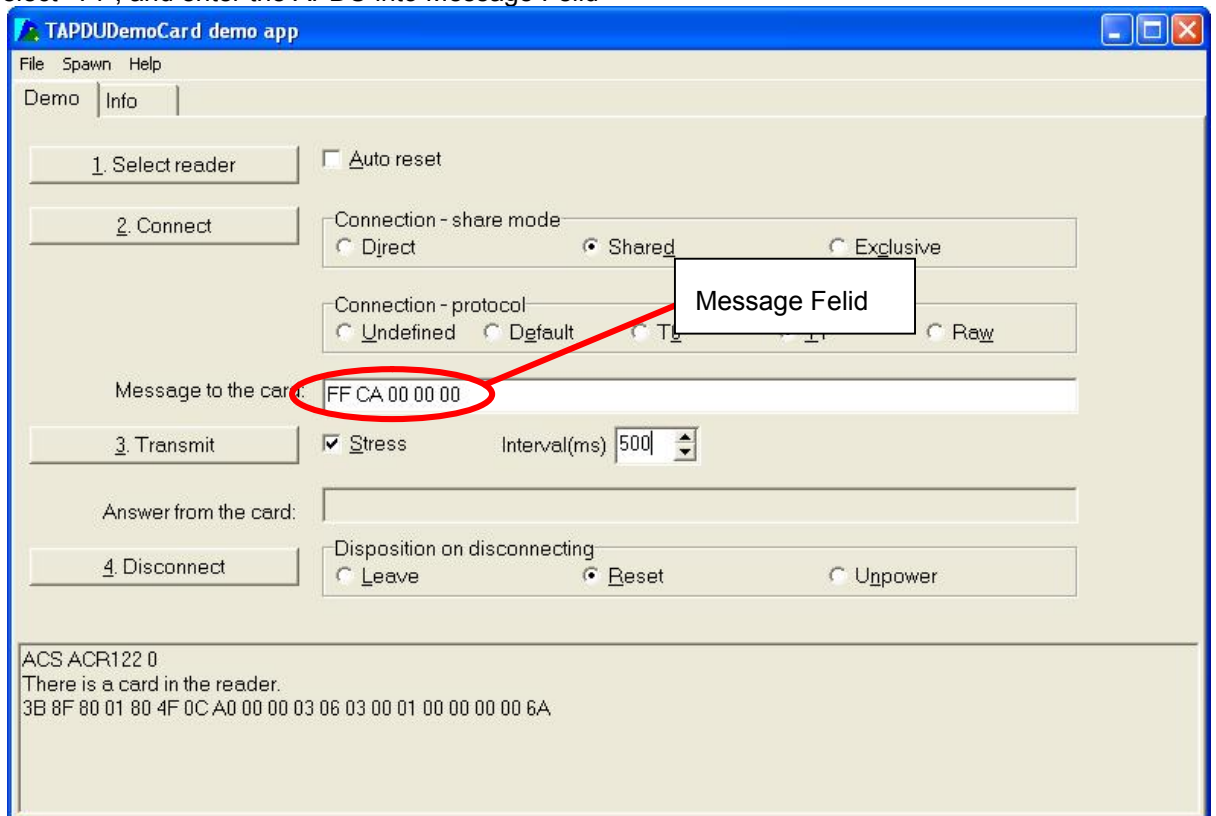

5. Press "Connect"
6. Press "Transmit" to start the testing
7. Complete the operation



## Appendix A. Parameter sheet

### Device

ACR1251U-C Smart Card Reader/Writer

### Power supply

Supply voltage..... Regulated 5V DC

Supply current..... <200mA

### Universal Serial Bus Interface

Type ..... USB, four lines: +5V, GND, D+ and D-

Connector ..... supplied together with the reader

Speed..... Full Speed Device, 12 Mbps

### Contact Smart Card Interface

Standard ..... ISO 7816 1/2/3/4, T=0 and T=1

Supply current..... max. 50mA

Smart card voltage ..... 5V / 3V / 1.8V

Smart card read / write speed ..... 9600 – 344kbps

Short circuit protection ..... +5V / GND on all pins

CLK frequency ..... 4.8 MHz

Card connector..... Landing

Card insertion cycles..... min. 100,000

### SAM Smart Card Interface

Standard ..... ISO 7816 1/2/3, T=0 and T=1

Supply current..... max. 50mA

Smart card voltage ..... 5V

Smart card read / write speed ..... 9600 – 344kbps

Short circuit protection ..... +5V / GND on all pins

CLK frequency ..... 4.0MHz

### Contactless Smart Card Interface

Standard..... ISO 14443 A & B Parts 1-4, ISO 18092

Protocol ..... ISO14443 T=CL for ISO14443-4 compliant cards and T=CL Emulation for MIFARE 1K/4K

Smart card read / write speed..... 106 kbps, 212 kbps, 424 kbps

### Operating Frequency for Contactless Cards Access

Operating Frequency..... 13.56 MHz

### Antenna

Antenna Size ..... 64mm x 55mm

Operating distance ..... up to 50 mm (Depend on Card Type)

### Built-in peripherals

Monotone buzzer

2x Single Color LED



**Case**

Dimensions ..... 120.48 mm (L) x 71.97 mm (W) x 20.4 mm (H)  
Color ..... Black

**Operating Conditions**

Temperature..... 0 - 50° C  
Humidity ..... 10% - 80%

**Cable Connector**

Length ..... 1.5m (USB)

**Standard/Certifications**

CE, FCC, VCCI, RoHS

**OS**

Windows 98, ME, 2K, XP, 7

**OEM**

OEM-Logo possible, customer-specific colors, casing, and card connector

**FCC Caution:**

Any Changes or modifications not expressly approved by the party responsible for compliance could void the user's authority to operate the equipment.

This device complies with part 15 of the FCC Rules. Operation is subject to the following two conditions: (1) This device may not cause harmful interference, and (2) this device must accept any interference received, including interference that may cause undesired operation.