

FCC PART 15.225
EMI MEASUREMENT AND TEST REPORT

For

Advanced Card Systems Ltd.

Units 2010-2013, 20th Floor, Chevalier Commercial Centre, 8 Wang Hoi Road,
Kowloon Bay, Hong Kong

FCC ID: V5MACR1222S

Report Type: Original Report	Product Type: Contactless Smart Card Reader and Writer
Test Engineer: Wayne Cheng	<i>Wayne Cheng</i>
Report Number: RSZ11022103	
Report Date: 2011-03-24	
Reviewed By: EMC Manager	<i>Merry Zhao</i>
Prepared By: Bay Area Compliance Laboratories Corp. (Shenzhen) 6/F, the 3rd Phase of WanLi Industrial Building, ShiHua Road, FuTian Free Trade Zone Shenzhen, Guangdong, China Tel: +86-755-33320018 Fax: +86-755-33320008	

Note: This test report is prepared for the customer shown above and for the device described herein. It may not be duplicated or used in part without prior written consent from Bay Area Compliance Laboratories Corp. This report **must not** be used by the customer to claim product certification, approval, or endorsement by NVLAP*, NIST, or any agency of the Federal Government.

* This report contains data that are not covered by the NVLAP accreditation and are marked with an asterisk "★" (Rev.2)

TABLE OF CONTENTS

GENERAL INFORMATION.....	4
PRODUCT DESCRIPTION FOR EQUIPMENT UNDER TEST (EUT)	4
OBJECTIVE	4
RELATED SUBMITTAL(S)/GRANT(S).....	4
TEST METHODOLOGY	4
TEST FACILITY	4
SYSTEM TEST CONFIGURATION.....	6
JUSTIFICATION	6
EUT EXERCISE SOFTWARE	6
EQUIPMENT MODIFICATIONS	6
HOST SYSTEM CONFIGURATION LIST AND DETAILS	6
LOCAL SUPPORT EQUIPMENT LIST AND DETAILS	6
EXTERNAL I/O CABLE.....	6
CONFIGURATION OF TEST SETUP	7
BLOCK DIAGRAM OF TEST SETUP	7
SUMMARY OF TEST RESULTS	8
FCC §15.203 - ANTENNA REQUIREMENT.....	9
APPLICABLE STANDARD	9
ANTENNA CONNECTED CONSTRUCTION	9
FCC §15.207 – AC LINE CONDUCTED EMISSION	10
MEASUREMENT UNCERTAINTY	10
EUT SETUP	10
EMI TEST RECEIVER SETUP.....	11
TEST PROCEDURE	11
TEST EQUIPMENT LIST AND DETAILS.....	11
TEST RESULTS SUMMARY.....	11
TEST DATA	11
FCC §15.225(D), §15.205 & §15.209- RADIATED EMISSIONS TEST.....	14
MEASUREMENT UNCERTAINTY	14
EUT SETUP.....	14
EMI TEST RECEIVER SETUP.....	15
CORRECTED AMPLITUDE & MARGIN CALCULATION	15
TEST EQUIPMENT LIST AND DETAILS.....	15
TEST RESULTS SUMMARY	15
TEST DATA	16
FCC §15.225(A) (B) (C) – FIELD STRENGTH OF RADIATED EMISSIONS.....	18
APPLICABLE STANDARD	18
EUT SETUP.....	18
TEST EQUIPMENT LIST AND DETAILS.....	18
TEST DATA	18
FCC §15.225(E) - FREQUENCY STABILITY.....	22
APPLICABLE STANDARD	22
TEST EQUIPMENT LIST AND DETAILS.....	22
TEST PROCEDURE	22

TEST DATA	22
FCC §15.215(C) – 20 DB EMISSION BANDWIDTH.....	24
APPLICABLE STANDARD	24
TEST PROCEDURE	24
TEST EQUIPMENT LIST AND DETAILS.....	24
TEST DATA	24

GENERAL INFORMATION

Product Description for Equipment Under Test (EUT)

The *Advanced Card Systems Ltd.*'s product, model number: *ACR1222S (FCC ID: V5MACR1222S)* or the "EUT" as referred to in this report is a *Contactless Smart Card Reader and Writer*. The EUT is measured approximately 12.3 cm (L) x 7.5 cm (W) x 2.0 cm (H). Rated input voltage: USB port 5V.

** All measurement and test data in this report was gathered from production sample serial number: RR149-XXXXXX (Assigned by applicant). The EUT was received on 2011-02-21.*

Objective

This Type approval report is prepared on behalf of *Advanced Card Systems Ltd.* in accordance with Part 2, Subpart J, and Part 15, Subparts A, B and C of the Federal Communication Commissions rules.

The objective is to determine compliance with FCC rules, sec 15.203, 15.205, 15.207, 15.209 and 15.225.

Related Submittal(s)/Grant(s)

No Related Submittals.

Test Methodology

All measurements contained in this report were conducted with ANSI C63.4-2009, American National Standard for Methods of Measurement of Radio-Noise Emissions from Low-Voltage Electrical and Electronic Equipment in the range of 9 kHz to 40 GHz.

All radiated and conducted emissions measurement was performed at Bay Area Compliance Lab Corp. (Shenzhen). The radiated testing was performed at an antenna-to-EUT distance of 3 meters.

Test Facility

The Test site used by Bay Area Compliance Laboratories Corp.(Shenzhen) to collect test data is located in the 6/F, the 3rd Phase of WanLi Industrial Building, ShiHua Road, FuTian Free Trade Zone Shenzhen, Guangdong, China.

Test site at Bay Area Compliance Laboratories Corp. (Shenzhen) has been fully described in reports submitted to the Federal Communication Commission (FCC). The details of these reports have been found to be in compliance with the requirements of Section 2.948 of the FCC Rules on December 06, 2010. The facility also complies with the radiated and AC line conducted test site criteria set forth in ANSI C63.4-2009.

The Federal Communications Commission has the reports on file and is listed under FCC Registration No.: 382179. The test site has been approved by the FCC for public use and is listed in the FCC Public Access Link (PAL) database.

Additionally, Bay Area Compliance Laboratories Corp. (Shenzhen) is a National Institute of Standards and Technology (NIST) accredited laboratory, under the National Voluntary Laboratory Accredited Program (Lab Code 200707-0).



The current scope of accreditations can be found at <http://ts.nist.gov/Standards/scopes/2007070.htm>

SYSTEM TEST CONFIGURATION

Justification

The system was configured for testing in a typical fashion (as normally used by a typical user).

EUT Exercise Software

The software was provided by the manufacture.

Equipment Modifications

Bay Area Compliance Lab Corp. (Shenzhen) has not done any modification on the EUT.

Host System Configuration List and Details

Manufacturer	Description	Model	Serial Number	FCC ID
DELL	Motherboard	OWC297	CN-OWC297-70821-564-00NI	DoC
DELL	Power	NPS-250KB D	CN-0H2678-17972-56E-80BM	DoC
Seagate	Hard Disk	ST340014A	5JXK3GXE	DoC
DELL	3.5' Floppy	N/A	CN-0N8893-69802-54Q-02P0	DoC
Lite-ON	CD-Rom	LTN-489S	N/A	DoC
ProMOS	Memory	V826632K24SATG-C0	0525-K1933700	N/A
Intel	CPU	Celeron D-2533	N/A	N/A
Intel	Ethernet	PRO 10/100 VE	N/A	DoC

Local Support Equipment List and Details

Manufacturer	Description	Model	Serial Number	FCC ID
DELL	PC	DELL 170L	CN-0TC670-70821-560-F4WQ	DoC
DELL	Keyboard	L100	CNORH656658907BL04TY	DoC
DELL	Mouse	MOC5UO	G1B0096D	DoC
DELL	LCD Monitor	E178WFPC	CNOWY564-64180-7C4-2SQH	DoC
N/A	Card	N/A	N/A	N/A

External I/O Cable

Cable Description	Length (M)	From/Port	To
Unshielded Undetachable Power Cable	1.8	PC	LISN
Unshielded Undetachable USB Cable with a Core	2.0	EUT	PC

Configuration of Test Setup

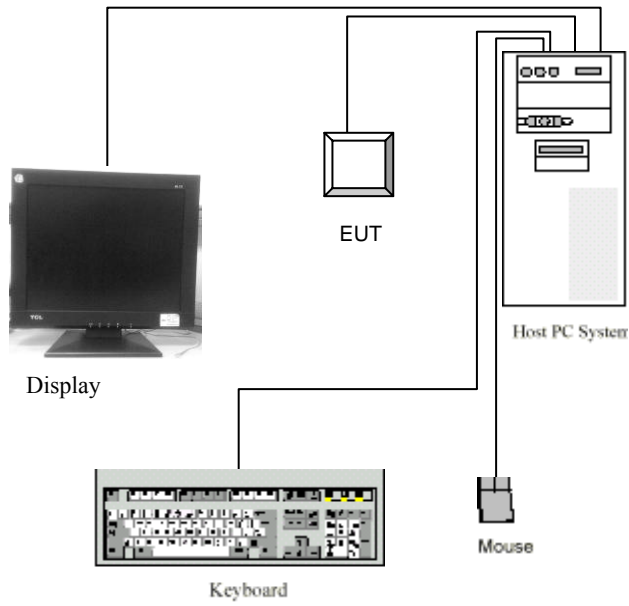

Block Diagram of Test Setup

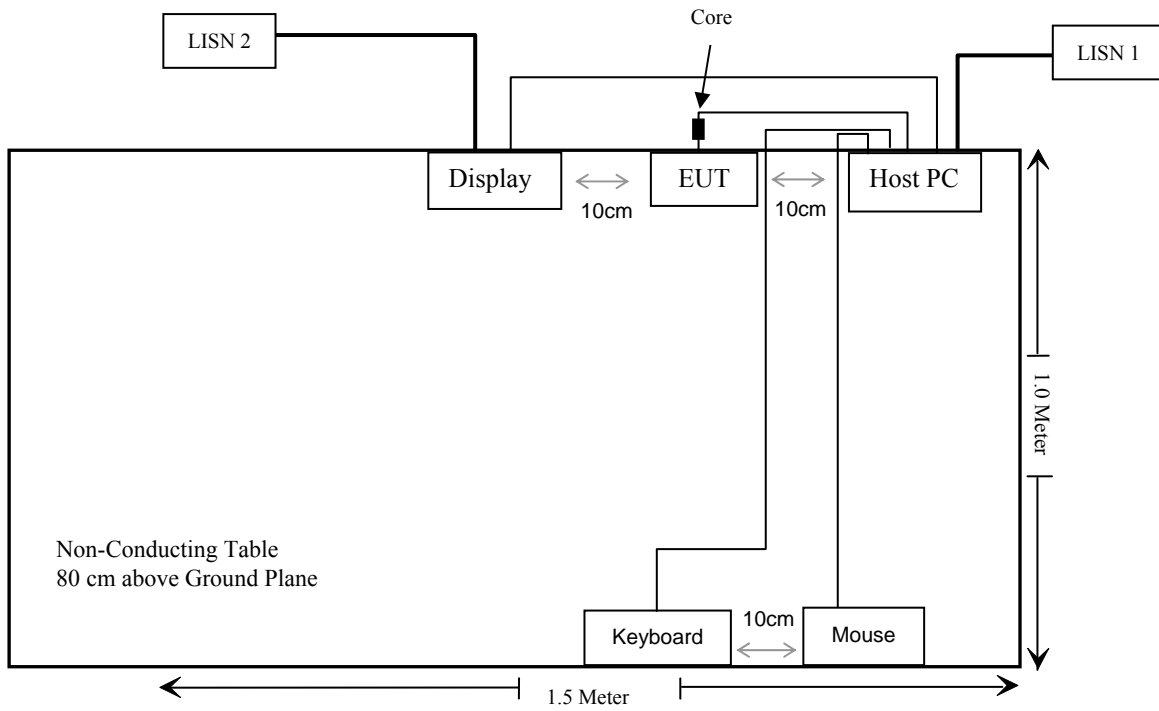

SUMMARY OF TEST RESULTS

FCC Rules	Description of Test	Result
§15.203	Antenna Requirement	Compliance
§15.207	AC Line Conducted Emission	Compliance
§15.225(d) §15.209§15.205	Radiated Emission Test	Compliance
§15.225(a) (b) (c)	Field Strength of Radiated Emissions	Compliance
§15.225(e)	Frequency Stability	Compliance
§15.215(c)	20 dB Emission Bandwidth	Compliance

FCC §15.203 - ANTENNA REQUIREMENT

Applicable Standard

An intentional radiator shall be designed to ensure that no antenna other than that furnished by the responsible party shall be used with the device. The use of a permanently attached antenna or of an antenna that uses a unique coupling to the intentional radiator shall be considered sufficient to comply with the provisions of this section.

Antenna Connected Construction

The EUT has a printed antenna on PCB, which complies with the Part 15.203. Please see EUT photo for details.

FCC §15.207 – AC LINE CONDUCTED EMISSION

Measurement Uncertainty

All measurements involve certain levels of uncertainties, especially in field of EMC. The factors contributing to uncertainties are spectrum analyzer, cable loss, and LISN.

Based on NIS 81, The Treatment of Uncertainty in EMC Measurements, the best estimate of the uncertainty of any conducted emissions measurement at Bay Area Compliance Lab Corp. (Shenzhen) is ± 2.4 dB(k=2, 95% level of confidence).

EUT Setup

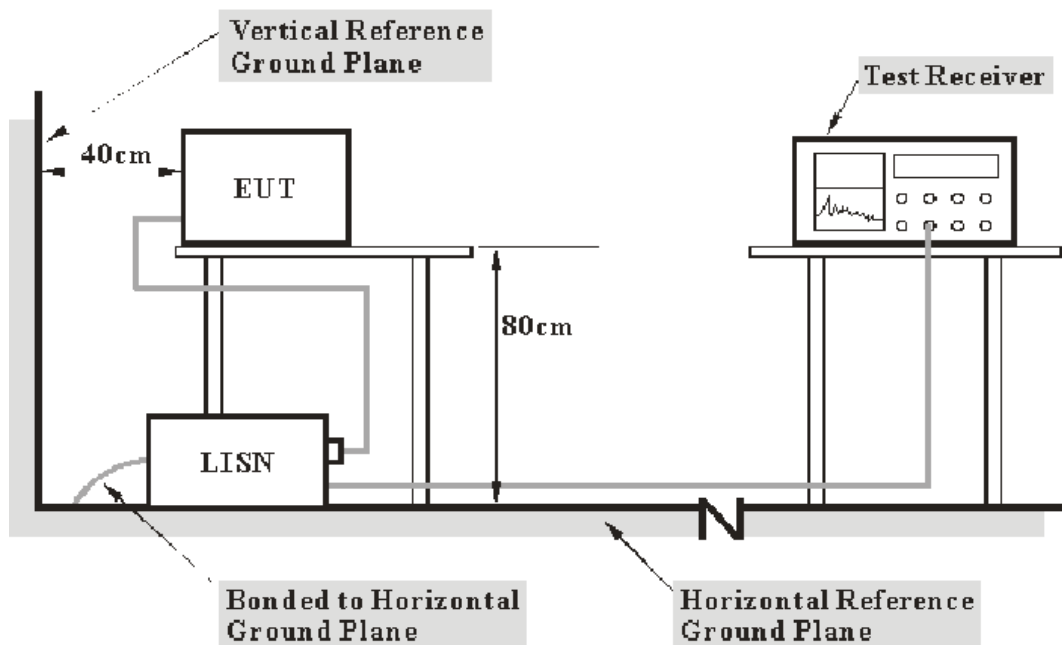

- Note:**
1. Support units were connected to second LISN.
 2. Both of LISNs (AMN) 80 cm from EUT and at the least 80 cm from other units and other metal planes support units.

The setup of EUT is according with per ANSI C63.4-2009 measurement procedure. The specification used was with the FCC Part 15.207.

The external I/O cables were draped along the test table and formed a bundle 30 to 40 cm long in the middle.

The spacing between the peripherals was 10 cm.

The host PC was connected to a 120 VAC/60 Hz power source.

EMI Test Receiver Setup

The EMI test receiver was set to investigate the spectrum from 150 kHz to 30 MHz.

During the conducted emission test, the EMI test receiver was set with the following configurations:

<i>Frequency Range</i>	<i>IF B/W</i>
150 kHz – 30 MHz	9 kHz

Test Procedure

During the conducted emission test, the host PC was connected to the outlet of the first LISN, and the display was connected to the outlet of the second LISN.

Maximizing procedure was performed on the six (6) highest emissions of the EUT.

All data was recorded in the Quasi-peak and average detection mode.

Test Equipment List and Details

Manufacturer	Description	Model	Serial Number	Calibration Date	Calibration Due Date
Rohde & Schwarz	EMI Test Receiver	ESCS30	100035	2010-11-11	2011-11-10
Rohde & Schwarz	L.I.S.N.	ESH2-Z5	892107/021	2011-03-09	2012-03-08

* **Statement of Traceability:** Bay Area Compliance Lab Corp. (Shenzhen) attests that all calibrations have been performed in accordance to NVLAP requirements, traceable to the NIST.

Test Results Summary

According to the recorded data in following table, the EUT complied with the FCC Part 15.207, with the worst margin reading of:

11.52 dB at 0.600 MHz in the **Neutral** conductor mode

Test Data

Environmental Conditions

Temperature:	25 °C
Relative Humidity:	48 %
ATM Pressure:	100.0 kPa

The testing was performed by Wayne Cheng on 2011-03-17.

Test Mode: Transmitting

120 V, 60 Hz, Line:

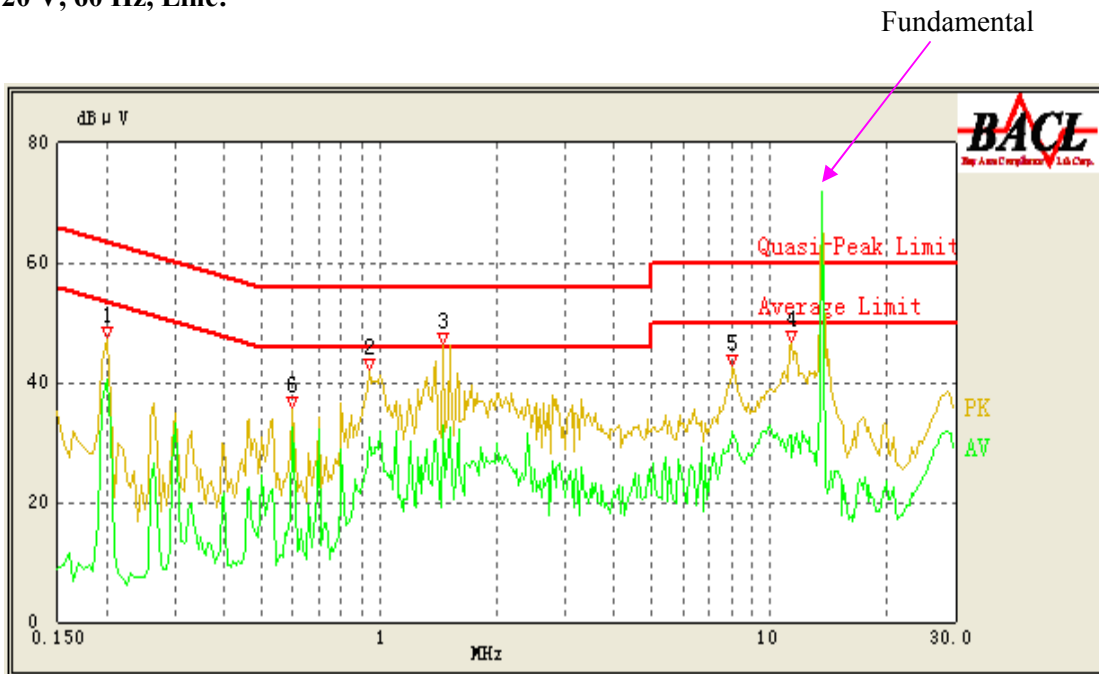

Frequency (MHz)	Cord. Result (dBμV)	Correction Factor (dB)	Limit (dBμV)	Margin (dB)	Remark (PK/QP/Ave.)
1.455	43.00	10.15	56.00	13.00	QP
1.455	32.89	10.15	46.00	13.11	Ave.
0.600	32.50	10.18	46.00	13.50	Ave.
0.200	40.35	10.07	54.57	14.22	Ave.
0.940	30.78	10.11	46.00	15.22	Ave.
8.055	31.73	10.10	50.00	18.27	Ave.
11.330	31.30	10.11	50.00	18.70	Ave.
11.330	41.25	10.11	60.00	18.75	QP
0.940	35.77	10.11	56.00	20.23	QP
0.200	43.87	10.07	64.57	20.70	QP
8.055	38.26	10.10	60.00	21.74	QP
0.600	33.51	10.18	56.00	22.49	QP

120 V, 60 Hz, Neutral:

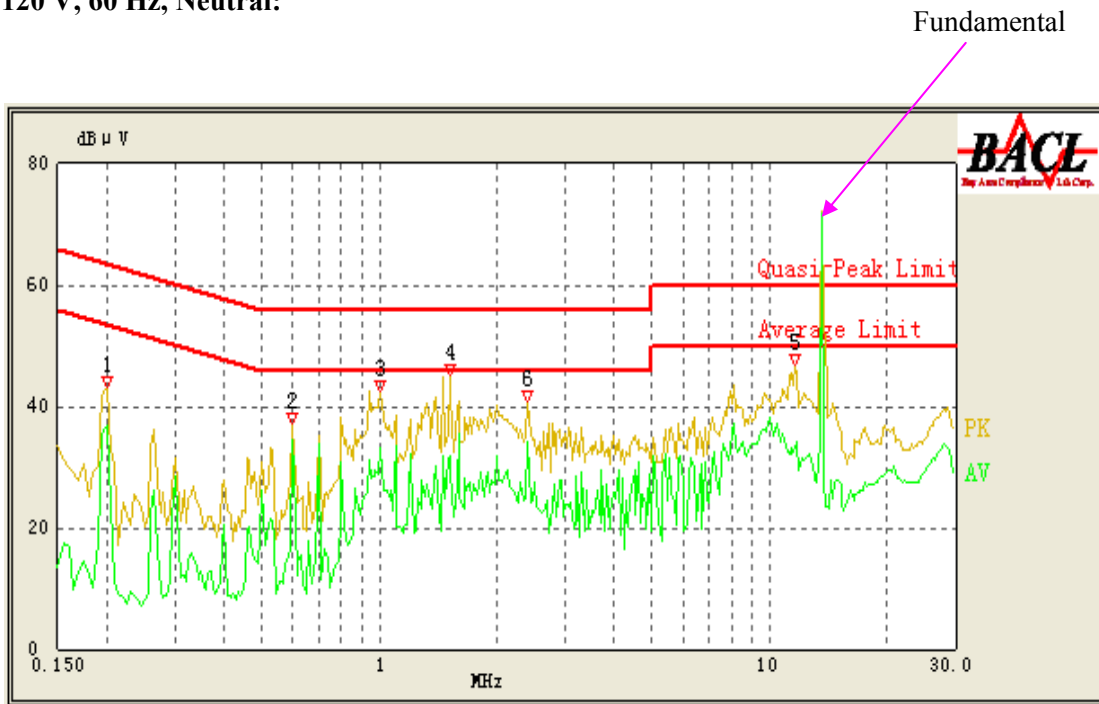

Frequency (MHz)	Cord. Result (dBμV)	Correction Factor (dB)	Limit (dBμV)	Margin (dB)	Remark (PK/QP/Ave.)
0.600	34.48	10.18	46.00	11.52	Ave.
2.405	34.25	10.18	46.00	11.75	Ave.
1.000	33.31	10.10	46.00	12.69	Ave.
1.520	41.94	10.15	56.00	14.06	QP
1.520	31.85	10.15	46.00	14.15	Ave.
11.620	33.15	10.12	50.00	16.85	Ave.
1.000	39.10	10.10	56.00	16.90	QP
0.200	36.71	10.07	54.57	17.86	Ave.
2.405	37.43	10.18	56.00	18.57	QP
11.625	40.70	10.12	60.00	19.30	QP
0.600	35.30	10.18	56.00	20.70	QP
0.200	40.93	10.07	64.57	23.64	QP

FCC §15.225(d), §15.205 & §15.209- RADIATED EMISSIONS TEST

Measurement Uncertainty

All measurements involve certain levels of uncertainties, especially in field of EMC. The factors contributing to uncertainties are spectrum analyzer, cable loss, antenna factor calibration, antenna directivity, antenna factor variation with height, antenna phase center variation, antenna factor frequency interpolation, measurement distance variation, site imperfections, mismatch (average), and system repeatability.

Based on NIS 81, The Treatment of Uncertainty in EMC Measurements, the best estimate of the uncertainty of a radiation emissions measurement at Bay Area Compliance Lab Corp. (Shenzhen) is ± 4.0 dB ($k=2$, 95% level of confidence).

The fundamental data was recorded in average detection mode: set the VBW AVE on, then record the data.

EUT Setup

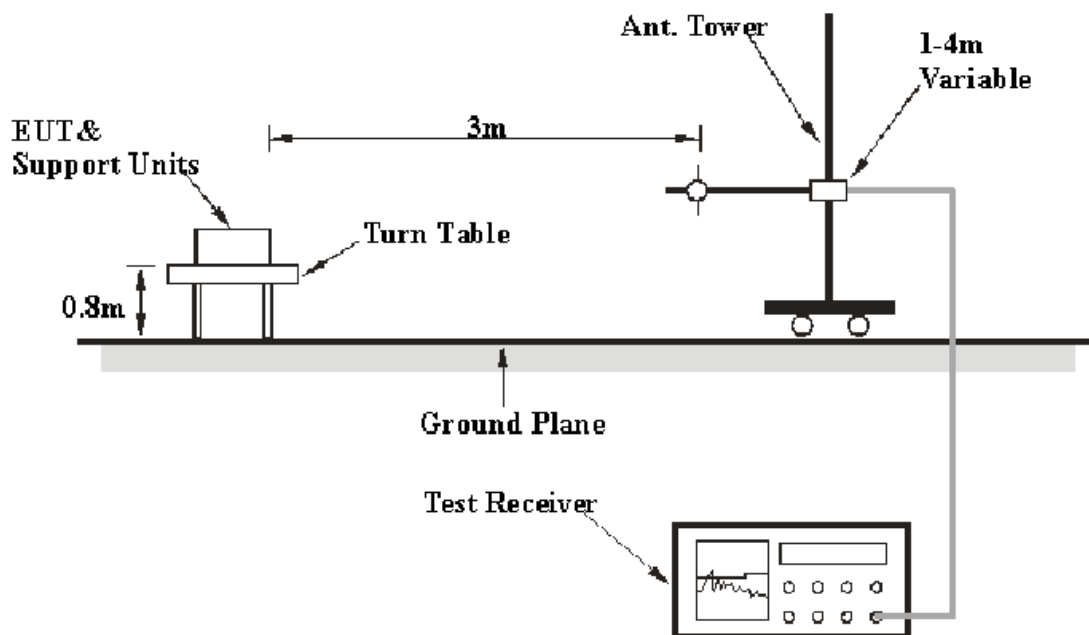

The radiated emission tests were performed in the 3-meter chamber a test site, using the setup accordance with the ANSI C63.4-2009. The specification used was the FCC Part Subpart C limits.

The spacing between the peripherals was 10 cm.

The host PC was connected to a 120 VAC/60 Hz power source.

EMI Test Receiver Setup

According to FCC Rules, 47 CFR 15.33, the EUT emissions were investigated up to 1000 MHz.

During the radiated emission test, the EMI test Receiver was set with the following configurations:

<i>Frequency Range</i>	<i>RBW</i>	<i>Video B/W</i>
9kHz – 150kHz	300Hz	1kHz
150kHz – 30MHz	10kHz	30kHz
30 – 1000 MHz	100 kHz	300 kHz

Corrected Amplitude & Margin Calculation

The Corrected Amplitude is calculated by adding the Antenna Loss and Cable Loss, and subtracting the Amplifier Gain from the Amplitude reading. The basic equation is as follows:

$$\text{Corr. Amp.} = \text{Meter Reading} + \text{Antenna Loss} + \text{Cable Loss} - \text{Amplifier Gain}$$

The “**Margin**” column of the following data tables indicates the degree of compliance with the applicable limit. For example, a margin of 7dB means the emission is 7dB below the maximum limit. The equation for margin calculation is as follows:

$$\text{Margin} = \text{Limit} - \text{Corr. Amp.}$$

Test Equipment List and Details

Manufacturer	Description	Model	Serial Number	Calibration Date	Calibration Due Date
Rohde & Schwarz	EMI Test Receiver	ESCI	100035	2010-11-11	2011-11-10
HP	Amplifier	8447E	1937A01046	2010-08-02	2011-08-01
Sunol Sciences	Broadband Antenna	JB1	A040904-1	2010-07-05	2011-07-04
ETS	Passive Loop Antenna	6512	00029604	2010-04-27	2011-04-26

* **Statement of Traceability:** Bay Area Compliance Lab Corp. (Shenzhen) attests that all calibrations have been performed per the NVLAP requirements, traceable to NIST.

Test Results Summary

According to the data in the following table, the EUT complied with the FCC Part 15.209 with the worst margin reading of:

0.4 dB at 40.685000 MHz in the Vertical polarization

Test Data**Environmental Conditions**

Temperature:	25 °C
Relative Humidity:	56 %
ATM Pressure:	100.9 kPa

The testing was performed by Wayne Cheng on 2011-03-15 to 2011-03-17.

Test mode: Transmitting

1) Below 30 MHz:

Indicated		Table Angle Degree	Antenna Height (m)	Detector PK/QP/AV	Correction Factor			Cord. Amp. (dB μ V/m) @3m	FCC Part 15.225	
Frequency (MHz)	Maximum Reading (dB μ V) @3m				Ant. Factor (dB)	Cable Loss (dB)	Pre-Amp. Gain (dB)		Limit (dB μ V/m) @3m	Result
14.12980	16.10	183	1.30	PK	31.7	0.20	0.0	48.00	69.5	Pass
21.10000	12.72	175	1.34	PK	31.2	0.27	0.0	44.19	69.5	Pass

2) 30 MHz – 1 GHz:

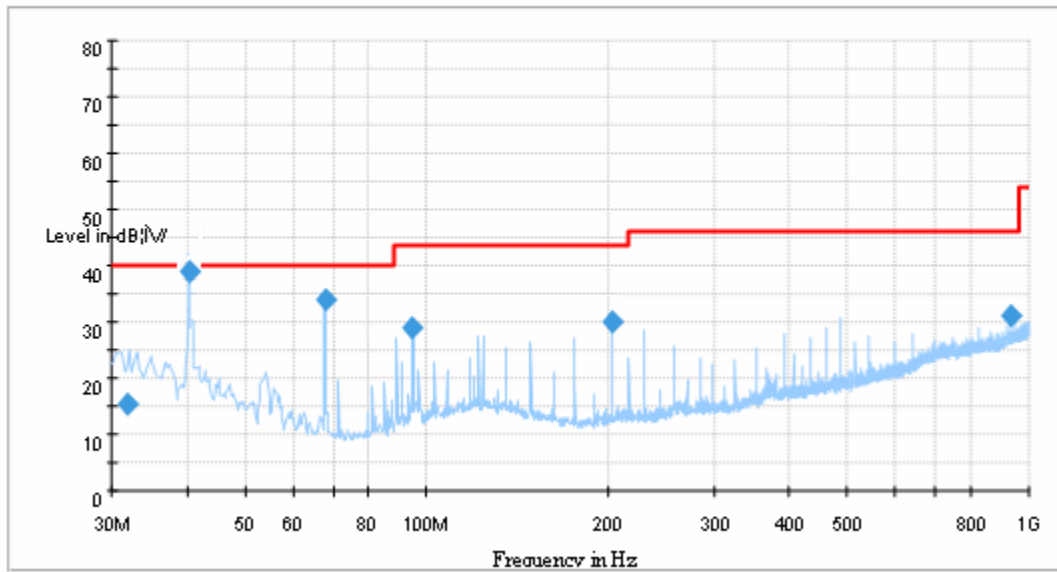

Frequency (MHz)	Corrected Amplitude (dBµV/m)	Antenna Height (cm)	Antenna Polarity (H/V)	Turntable Position (deg)	Correction Factor (dB)	Limit (dBµV/m)	Margin (dB)
40.685000	39.6	102.0	V	199.0	-12.5	40.0	0.4*
67.811250	33.8	261.0	H	252.0	-18.4	40.0	6.2
203.417750	30.1	140.0	H	84.0	-14.3	43.5	13.4
94.940500	29.1	195.0	H	130.0	-16.1	43.5	14.4
935.737750	31.1	303.0	H	62.0	0.3	46.0	14.9
31.804500	15.4	357.0	V	9.0	-6.7	40.0	24.6

*Within measurement uncertainty!

FCC §15.225(a) (b) (c) – FIELD STRENGTH OF RADIATED EMISSIONS

Applicable Standard

As per FCC Part 15.225

(a) The field strength of any emissions within the band 13.553-13.567 MHz shall not exceed 15,848 microvolts/meter at 30 meters.

(b) Within the bands 13.410-13.553 MHz and 13.567-13.710 MHz, the field strength of any emissions shall not exceed 334 microvolts/meter at 30 meters.

(c) Within the bands 13.110-13.410 MHz and 13.710-14.010 MHz the field strength of any emissions shall not exceed 106 microvolts/meter at 30 meters.

EUT Setup

The field strength of radiated emissions tests were performed in the 3-meter chamber test site, using the setup accordance with the ANSI C63.4-2009. The specification used was the FCC Part Subpart C limits.

Test Equipment List and Details

Manufacturer	Description	Model	Serial Number	Calibration Date	Calibration Due Date
HP	Amplifier	8447E	1937A01046	2010-08-02	2011-08-01
Rohde & Schwarz	EMI Test Receiver	ESCI	100035	2010-11-11	2011-11-10
ETS	Passive Loop Antenna	6512	00029604	2010-04-27	2011-04-26

* **Statement of Traceability:** Bay Area Compliance Lab Corp. (Shenzhen) attests that all calibrations have been performed per the NVLAP requirements, traceable to NIST.

Test Data

Environmental Conditions

Temperature:	25 °C
Relative Humidity:	56 %
ATM Pressure:	100.0 kPa

The testing was performed by Wayne Cheng on 2011-03-15.

Test Mode: Transmitting

Test Result: Pass

Indicated			Table Angle Degree	Antenna Height (m)	Detector PK/QP/Ave	Correction Factor			Cord. Amp. (dBµV/m) @3m	FCC Part 15.225	
Frequency Range (MHz)	Mark point (MHz)	Maximum Reading (dBµV/m) @3m				Ant. Factor (dB)	Cable Loss (dB)	Pre-Amp. Gain (dB)		Limit (dBµV/m) @3m	Result
13.110-13.410	13.380	1.9	169	1.30	QP	32.1	0.2	0	34.2	80.5	Pass
13.410-13.553	13.536	3.6	181	1.32	QP	32.1	0.2	0	35.9	90.5	Pass
13.553-13.567	13.560	26.9	183	1.35	QP	32.1	0.2	0	59.2	124	Pass
13.567-13.710	13.566	22.6	173	1.28	QP	32.1	0.2	0	54.9	90.5	Pass
13.710-14.010	13.810	-1.0	186	1.38	QP	32.1	0.2	0	31.3	80.5	Pass

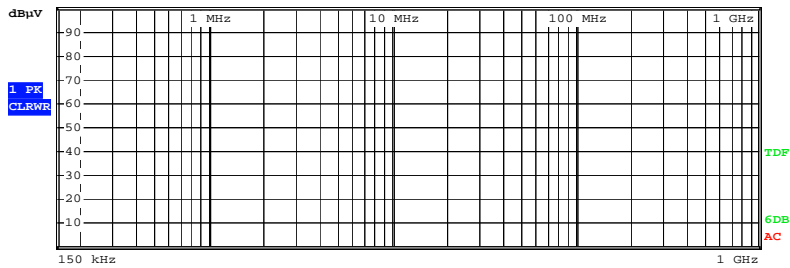
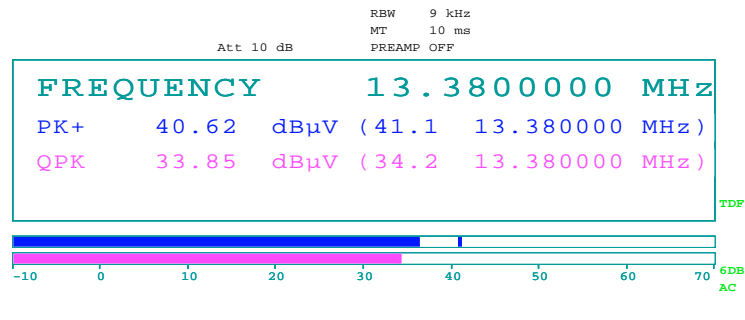

Date: 15.MAR.2011 21:56:40

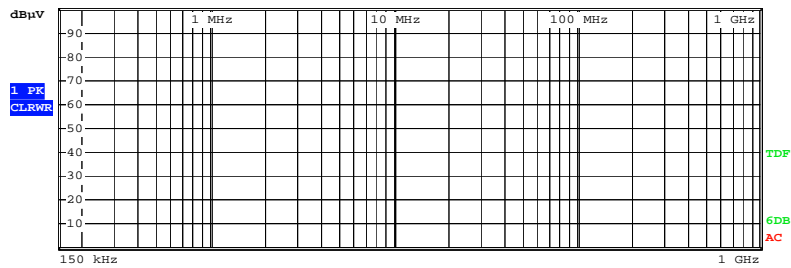
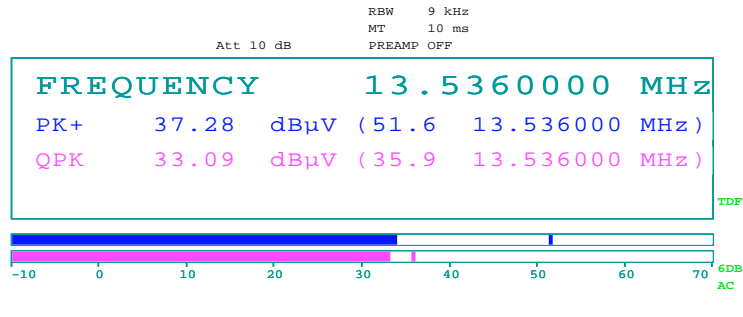

Date: 15.MAR.2011 21:53:34

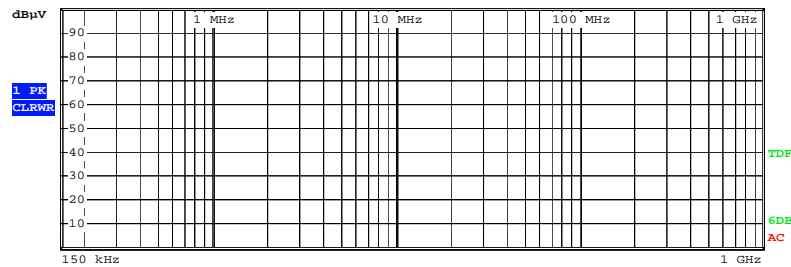
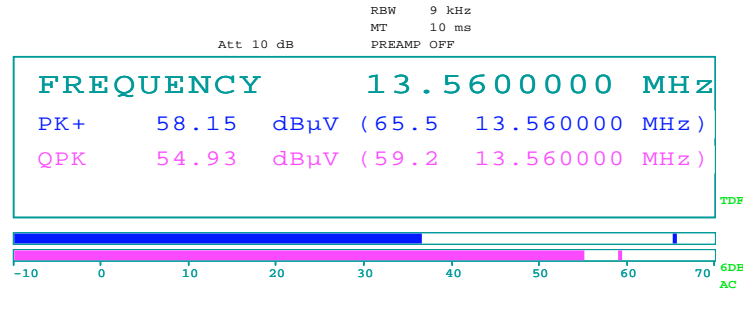

Date: 15.MAR.2011 21:54:21

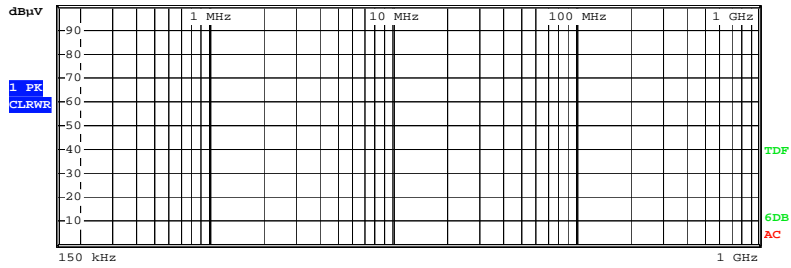
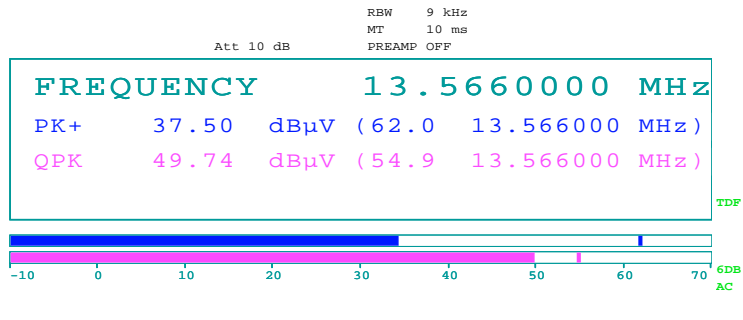

Date: 15.MAR.2011 21:55:10

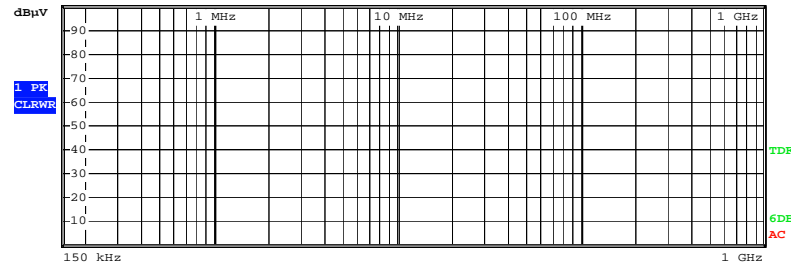
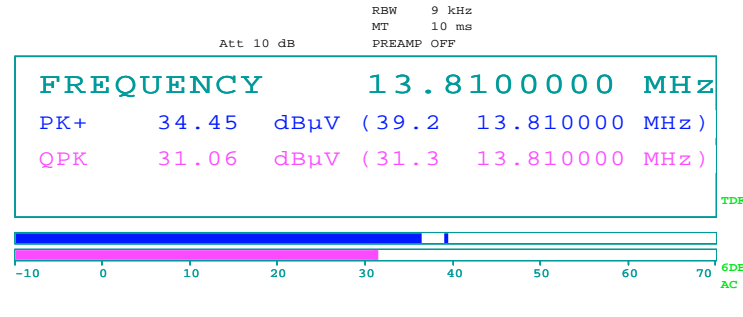

Date: 15.MAR.2011 21:56:04

FCC §15.225(e) - FREQUENCY STABILITY

Applicable Standard

The frequency tolerance of the carrier signal shall be maintained within $\pm 0.01\%$ of the operating frequency over a temperature variation of -20 degrees to $+50$ degrees C at normal supply voltage, and for a variation in the primary supply voltage from 85% to 115% of the rated supply voltage at a temperature of 20 degrees C. For battery operated equipment, the equipment tests shall be performed using a new battery.

Test Equipment List and Details

Manufacturer	Description	Model	Serial Number	Calibration Date	Calibration Due Date
Rohde & Schwarz	EMI Test Receiver	ESCI	100035	2010-11-11	2011-11-10
WUHUAN	Temperature & Humidity Chamber	HTP205	20021115	2010-06-04	2011-06-03

* **Statement of Traceability:** Bay Area Compliance Lab Corp. (Shenzhen) attests that all calibrations have been performed in accordance to NVLAP requirements, traceable to the NIST.

Test Procedure

Frequency Stability vs. Temperature: The equipment under test was connected to PC, than to an external AC power supply and loop antenna was connected to a f Spectrum Analyzer. The EUT was placed inside the temperature chamber.

After the temperature stabilized for approximately 20 minutes, the frequency output was recorded from the Spectrum Analyzer.

Frequency Stability vs. Voltage: An external variable AC power supply Source. The voltage was set to 115% of the nominal value and was then decreased until the transmitter light no longer illuminated; i.e., the end point. The output frequency was recorded for each voltage.

Test Data

Environmental Conditions

Temperature:	25 °C
Relative Humidity:	50 %
ATM Pressure:	100.0 kPa

The testing was performed by Wayne Cheng on 2011-03-17.

Test Result: Pass

Test Mode: Transmitting

Power Supply	Temperature (°C)	Measured Frequency (MHz)	Frequency Error	Part 15.225 Limit
AC 120 V	0	13.56050	0.0037%	± 0.01%
	10	13.56044	0.0032%	± 0.01%
	20	13.56041	0.0030%	± 0.01%
	25	13.56036	0.0027%	± 0.01%
	30	13.56025	0.0018%	± 0.01%
	40	13.56043	0.0032%	± 0.01%
	50	13.56037	0.0027%	± 0.01%
Max. = AC 138 V	20	13.56047	0.0035%	± 0.01%
Min. = AC 102 V	20	13.56065	0.0048%	± 0.01%

FCC §15.215(c) – 20 dB EMISSION BANDWIDTH

Applicable Standard

Per FCC §15.215 (c) Intentional radiators operating under the alternative provisions to the general emission limits, as contained in §15.217 through § 15.257 and in Subpart E of this part, must be designed to ensure that the 20 dB bandwidth of the emission, or whatever bandwidth may otherwise be specified in the specific rule section under which the equipment operates, is contained within the frequency band designated in the rule section under which the equipment is operated. The requirement to contain the designated bandwidth of the emission within the specified frequency band includes the effects from frequency sweeping, frequency hopping and other modulation techniques that may be employed as well as the frequency stability of the transmitter over expected variations in temperature and supply voltage. If a frequency stability is not specified in the regulations, it is recommended that the fundamental emission be kept within at least the central 80% of the permitted band in order to minimize the possibility of out-of-band operation.

Test Procedure

1. Check the calibration of the measuring instrument using either an internal calibrator or a known signal from an external generator.
2. Position the EUT without connection to measurement instrument. Turn on the EUT and connect it to measurement instrument. Then set it to any one convenient frequency within its operating range. Set a reference level on the measuring instrument equal to the highest peak value.
3. Measure the frequency difference of two frequencies that were attenuated 20 dB from the reference level. Record the frequency difference as the emission bandwidth.

Test Equipment List and Details

Manufacturer	Description	Model	Serial Number	Calibration Date	Calibration Due Date
Rohde & Schwarz	EMI Test Receiver	ESCI	100035	2010-11-11	2011-11-10
HP	Amplifier	8447E	1937A01046	2010-08-02	2011-08-01
ETS	Passive Loop Antenna	6512	00029604	2010-04-27	2011-04-26

* **Statement of Traceability:** Bay Area Compliance Laboratories Corp. (Shenzhen) attests that all calibrations have been performed per the NVLAP requirements, traceable to NIST.

Test Data

Environmental Conditions

Temperature:	25 °C
Relative Humidity:	56 %
ATM Pressure:	100.9 kPa

The testing was performed by Wayne Cheng on 2011-03-15.

Test Mode: Transmitting

20 dB Emission Bandwidth

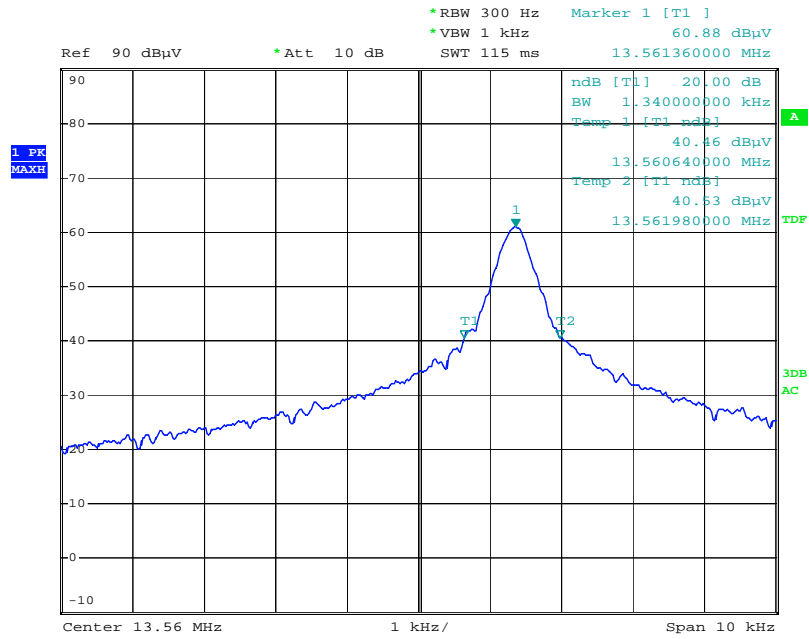

Date: 15.MAR.2011 21:47:07

***** END OF REPORT *****