



FCC 47 CFR PART 15 SUBPART C

Product Type : ADSL2+ Wireless Router
Applicant : Shenzhen Gongjin Electronics Co.,Ltd
Address : B116、B118 ; B201-B213 ; A311-313 ; B411-413 ; BF08-09 ; B115 ;
B401-403 Nanshan Medical Instrument Industry Park,1019#
Nanhai Road,NanshanDistrict,Shenzhen,Guangdong,518067,
P.R.China

Trade Name : NUCOM
Model Number : R5500UN, GAN5.PT156A-B

Test Specification : FCC 47 CFR PART 15 SUBPART C: Oct., 2013
ANSI C63.4:2009
Receive Date : December 09, 2014
Test Period : December 10, 2014~April 08, 2015
Issue Date : April 10, 2015

Issue by

A Test Lab Techno Corp.
No. 140-1, Changan Street, Bade City,
Taoyuan County 334, Taiwan R.O.C.
Tel : +886-3-2710188 / Fax : +886-3-2710190



Taiwan Accreditation Foundation accreditation number: 1330

Note: This report shall not be reproduced except in full, without the written approval of A Test Lab Techno Corp. This document may be altered or revised by A Test Lab Techno Corp. personnel only, and shall be noted in the revision section of the document. The client should not use it to claim product endorsement by TAF, or any government agencies. The test results in the report only apply to the tested sample.



Revision History

Rev.	Issue Date	Revisions	Revised By
00	April. 10, 2015	Initial Issue	



Verification of Compliance

Issued Date: 04/10/2014

Product Type : ADSL2+ Wireless Router

Applicant : Shenzhen Gongjin Electronics Co.,Ltd

Address : B116、 B118; B201-B213; A311-313; B411-413; BF08-09; B115; B401-403 Nanshan Medical Instrument Industry Park,1019# Nanhai Road, NanshanDistrict,Shenzhen, Guangdong, 518067,P.R.China

Trade Name : NUCOM

Model Number : R5500UN, GAN5.PT156A-B

FCC ID : V4VR5500UN

EUT Rated Voltage : DC 12V, 1A

Test Voltage : AC 120V/60Hz

Applicable Standard : FCC 47 CFR PART 15 SUBPART C: Oct., 2013
ANSI C63.10:2013

Test Result : Complied

Performing Lab. : A Test Lab Techno Corp.
No. 140-1, Changan Street, Bade City,
Taoyuan County 334, Taiwan R.O.C.
Tel : +886-3-2710188 / Fax : +886-3-2710190
Taiwan Accreditation Foundation accreditation number: 1330
<http://www.atl-lab.com.tw/e-index.htm>



The above equipment was tested by A Test Lab Techno Corp. The test data, data evaluation, test procedures, and equipment configurations shown in this report were made in accordance with the procedures given in ANSI C63.4: 2009 and the energy emitted by the sample tested as described in this report is in compliance with the requirements of FCC Rules Part 15.207, 15.209, 15.247 .

The test results of this report relate only to the tested sample identified in this report.

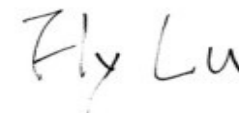
Approved By :  Reviewed By : 

(Manager) (Murphy Wang) (Testing Engineer) (Fly Lu)



TABLE OF CONTENTS

1	General Information	6
2	EUT Description.....	7
3	Test Methodology.....	8
3.1.	Mode of Operation	8
3.2.	EUT Exercise Software.....	9
3.3.	Configuration of Test System Details	9
3.4.	Test Site Environment.....	10
4	Conducted Emission Measurement.....	11
4.1.	Limit.....	11
4.2.	Test Instruments	11
4.3.	Test Setup.....	11
4.4.	Test Procedure.....	12
4.5.	Test Result.....	13
5	Radiated Emission Measurement	15
5.1.	Limit.....	15
5.2.	Test Instruments	15
5.3.	Test Setup.....	16
5.4.	Test Procedure.....	17
5.5.	Test Result.....	18
6	Maximum Conducted Output Power Measurement.....	23
6.1.	Limit.....	23
6.2.	Test Setup.....	23
6.3.	Test Instruments	23
6.4.	Test Procedure.....	23
6.5.	Test Result.....	24
7	6dB RF Bandwidth and 99 % Occupied Bandwidth Measurement.....	25
7.1.	Limit.....	25
7.2.	Test Setup.....	25
7.3.	Test Instruments	25
7.4.	Test Procedure.....	25
7.5.	Test Result.....	26
7.6.	Test Graphs	27
8	Maximum Power Density Measurement	31
8.1.	Limit.....	31
8.2.	Test Setup.....	31
8.3.	Test Instruments	31
8.4.	Test Procedure.....	31
8.5.	Test Result.....	32
8.6.	Test Graphs	34
9	Out of Band Conducted Emissions Measurement	38



9.1. Limit.....	38
9.2. Test Setup.....	38
9.3. Test Instruments	38
9.4. Test Procedure.....	38
9.5. Test Graphs	39
10 Band Edges Measurement.....	71
10.1. Limit.....	71
10.2. Test Setup.....	71
10.3. Test Instruments	71
10.4. TEST CONFIGURATION.....	72
10.5. Test Result.....	73
11 Antenna Measurement	85
11.1. Limit.....	85
11.2. Antenna Connector Construction.....	85
11.3. Measurement Parameters	85
11.4. TEST RESULTS	85
12 Letter for Product Equality Declaration.....	87



1 General Information

1.1 Summary of Test Result

Standard	Item	Result	Remark
15.247			
15.207	AC Power Conducted Emission	PASS	-----
15.209	Receiver Radiated Emissions	PASS	-----
15.247(d)	Transmitter Radiated Emissions	PASS	-----
15.247(b)(3)	Max. Output Power	PASS	-----
15.247(a)(2)	6dB RF Bandwidth	PASS	-----
15.247(e)	Power Spectral Density	PASS	-----
15.247(d)	Out of Band Conducted Spurious Emission	PASS	-----
15.247(d)	Band Edge Measurement	PASS	-----
15.203	Antenna Requirement	PASS	-----

The test results of this report relate only to the tested sample(s) identified in this report. Manufacturer or whom it may concern should recognize the pass or fail of the test result.

1.2 Measurement Uncertainty

Test Item	Frequency Range	Uncertainty (dB)	
Conducted Emission	9kHz ~ 30MHz	± 2.02	
Radiated Emission	30MHz ~ 1000MHz	Horizontal	± 3.98
		Vertical	± 3.62
	1000MHz ~ 18000MHz	Horizontal	± 3.11
		Vertical	± 3.07
	18000MHz ~ 40000MHz	Horizontal	± 3.66
		Vertical	± 3.54



2 EUT Description

Product Type	ADSL2+ Wireless Router
Trade Name	NUCOM
Model No.	R5500UN, GAN5.PT156A-B
Model different	The only difference between these two models is the model name.
Test Model Number	GAN5.PT156A-B
Applicant	Shenzhen Gongjin Electronics Co.,Ltd B116、B118; B201-B213; A311-313; B411-413; BF08-09; B115; B401-403 Nanshan Medical Instrument Industry Park,1019# Nanhai Road,Nanshan District,Shenzhen,Guangdong,518067,P.R.China
Manufacturer	Shenzhen Gongjin Electronics Co.,Ltd B116;B118;B201-B213;A311-313;B411-413;BF08-09;B115;B401-403 Nanshan Medical Instrument Industry Park,1019# Nanhai Road,Nanshan District,Shenzhen,Guangdong,518067,P.R.China
FCC ID	V4VR5500UN
Frequency Range	IEEE 802.11b / 802.11g / 802.11n 2.4GHz 20MHz: 2412 ~ 2462 MHz IEEE 802.11n 2.4GHz 40MHz: 2422 ~ 2452 MHz
Modulation Type	IEEE 802.11b:DSSS IEEE 802.11g:DSSS + OFDM IEEE 802.11n 2.4GHz 20MHz: OFDM IEEE 802.11n 2.4GHz 40MHz: OFDM
Antenna Type	External Antenna 5dBi & 3dBi; Internal Antenna 3dBi
Antenna Gain	5dBi & 3dBi
Antenna operating principle Describe	IEEE 802.11b: antenna 0 transmitting IEEE 802.11g: antenna 0 or antenna 1 transmitting IEEE 802.11n 2.4GHz 20MHz: antenna 0 and antenna 1 simultaneous transmission IEEE 802.11n 2.4GHz 40MHz: antenna 0 and antenna 1 simultaneous transmission
Antenna Delivery	TX + RX
RF Output Power	IEEE 802.11b: 0.097W / 19.94dBm IEEE 802.11g: 0.294W / 24.69dBm IEEE 802.11n 2.4GHz 20MHz: 0.210W / 23.23 dBm IEEE 802.11n 2.4GHz 40MHz: 0.240 W / 23.80 dBm
99 % Occupied Bandwidth	IEEE 802.11b: 10.149 MHz IEEE 802.11g: 16.308 MHz IEEE 802.11n 2.4GHz 20MHz: 17.470MHz IEEE 802.11n 2.4GHz 40MHz: 36.178 MHz
Adapter information	Model: S12B22-120A100-04 Input:100-240V~50/60Hz Max 0.5A Output:12V—1A Manufacturer: Shenzhen Gongjin Electronics Co.,Ltd



3 Test Methodology

3.1. Mode of Operation

Decision of Test ATL has verified the construction and function in typical operation. All the test modes were carried out with the EUT in normal operation, which was shown in this test report and defined as:

Test Mode
Mode 1: Normal Operation Mode
Mode 2: IEEE 802.11b Link Mode
Mode 3: IEEE 802.11g Link Mode
Mode 4: IEEE 802.11n 2.4GHz 20MHz Link Mode
Mode 5: IEEE 802.11n 2.4GHz 40MHz Link Mode
Mode 6: Receiver Mode

Mark:

- The product with three different antennas as for difference models (please see model different at end of test report), the RF modular is same; only antenna again and type different, please see more information as follows:

Test Item	Test Antenna Port	Test Antenna	Report Recorded
AC Power Conducted Emission	<input checked="" type="checkbox"/> port 0 <input type="checkbox"/> port 1	<input checked="" type="checkbox"/> External 5dBi <input checked="" type="checkbox"/> External 3dBi <input checked="" type="checkbox"/> Internal 3dBi	<input checked="" type="checkbox"/> External 5dBi
Radiated Emissions	802.11 b <input checked="" type="checkbox"/> port 0 <input type="checkbox"/> port 1 802.11 g <input checked="" type="checkbox"/> port 0 <input checked="" type="checkbox"/> port 1 802.11 nHT20 <input checked="" type="checkbox"/> port 0 <input checked="" type="checkbox"/> port 1 802.11 nHT40 <input checked="" type="checkbox"/> port 0 <input checked="" type="checkbox"/> port 1	<input checked="" type="checkbox"/> External 5dBi <input checked="" type="checkbox"/> External 3dBi <input checked="" type="checkbox"/> Internal 3dBi	<input checked="" type="checkbox"/> External 5dBi
Max. Output Power	802.11 b <input checked="" type="checkbox"/> port 0 <input type="checkbox"/> port 1 802.11 g <input checked="" type="checkbox"/> port 0 <input checked="" type="checkbox"/> port 1 802.11 nHT20 <input checked="" type="checkbox"/> port 0 <input checked="" type="checkbox"/> port 1 802.11 nHT40 <input checked="" type="checkbox"/> port 0 <input checked="" type="checkbox"/> port 1	<input type="checkbox"/> External 5dBi <input type="checkbox"/> External 3dBi <input type="checkbox"/> Internal 3dBi	<input type="checkbox"/> External 5dBi
6dB RF Bandwidth	802.11 b <input checked="" type="checkbox"/> port 0 <input type="checkbox"/> port 1 802.11 g <input checked="" type="checkbox"/> port 0 <input checked="" type="checkbox"/> port 1 802.11 nHT20 <input checked="" type="checkbox"/> port 0 <input checked="" type="checkbox"/> port 1 802.11 nHT40 <input checked="" type="checkbox"/> port 0 <input checked="" type="checkbox"/> port 1	<input type="checkbox"/> External 5dBi <input type="checkbox"/> External 3dBi <input type="checkbox"/> Internal 3dBi	<input type="checkbox"/> External 5dBi
Power Spectral Density	802.11 b <input checked="" type="checkbox"/> port 0 <input type="checkbox"/> port 1 802.11 g <input checked="" type="checkbox"/> port 0 <input checked="" type="checkbox"/> port 1 802.11 nHT20 <input checked="" type="checkbox"/> port 0 <input checked="" type="checkbox"/> port 1 802.11 nHT40 <input checked="" type="checkbox"/> port 0 <input checked="" type="checkbox"/> port 1	<input type="checkbox"/> External 5dBi <input type="checkbox"/> External 3dBi <input type="checkbox"/> Internal 3dBi	<input type="checkbox"/> External 5dBi
Out of Band Conducted Spurious Emission	802.11 b <input checked="" type="checkbox"/> port 0 <input type="checkbox"/> port 1 802.11 g <input checked="" type="checkbox"/> port 0 <input checked="" type="checkbox"/> port 1 802.11 nHT20 <input checked="" type="checkbox"/> port 0 <input checked="" type="checkbox"/> port 1	<input type="checkbox"/> External 5dBi <input type="checkbox"/> External 3dBi <input type="checkbox"/> Internal 3dBi	<input type="checkbox"/> External 5dBi



	802.11 nHT40 <input checked="" type="checkbox"/> port 0 <input checked="" type="checkbox"/> port 1		
Band Edge Measurement	802.11 b <input checked="" type="checkbox"/> port 0 <input type="checkbox"/> port 1	<input checked="" type="checkbox"/> External 5dBi	<input checked="" type="checkbox"/> External 5dBi
	802.11 g <input checked="" type="checkbox"/> port 0 <input checked="" type="checkbox"/> port 1	<input checked="" type="checkbox"/> External 3dBi	
	802.11 nHT20 <input checked="" type="checkbox"/> port 0 <input checked="" type="checkbox"/> port 1	<input checked="" type="checkbox"/> Internal 3dBi	
	802.11 nHT40 <input checked="" type="checkbox"/> port 0 <input checked="" type="checkbox"/> port 1		
Antenna Requirement	802.11 b <input checked="" type="checkbox"/> port 0 <input type="checkbox"/> port 1	<input checked="" type="checkbox"/> External 5dBi	<input checked="" type="checkbox"/> External 5dBi
	802.11 g <input checked="" type="checkbox"/> port 0 <input checked="" type="checkbox"/> port 1	<input checked="" type="checkbox"/> External 3dBi	
	802.11 nHT20 <input checked="" type="checkbox"/> port 0 <input checked="" type="checkbox"/> port 1	<input checked="" type="checkbox"/> Internal 3dBi	
	802.11 nHT40 <input checked="" type="checkbox"/> port 0 <input checked="" type="checkbox"/> port 1		

2. Software used to control the EUT for staying in continuous transmitting mode was programmed.

After verification, all tests were carried out with the worst case test modes as shown below except radiated spurious emission below 1GHz and power line conducted emissions below 30MHz, which worst case was in normal link mode only.

IEEE 802.11b mode:

Channel Low (2412MHz), Channel Mid (2437MHz) and Channel High (2462MHz) with 1Mbps data rate and cyclic delay diversity were chosen for full testing.

IEEE 802.11g mode:

Channel Low (2412MHz), Channel Mid (2437MHz) and Channel High (2462MHz) with 6Mbps data rate and cyclic delay diversity were chosen for full testing.

IEEE 802.11n 2.4GHz 20MHz mode:

Channel Low (2412MHz), Channel Mid (2437MHz) and Channel High (2462MHz) with MCS0 data rate were chosen for full testing.

IEEE 802.11n 2.4GHz 40MHz mode:

Channel Low (2422MHz), Channel Mid (2437MHz) and Channel High (2452MHz) with 13.5Mbps data rate were chosen for full testing.

By preliminary testing and verifying three axis (X, Y and Z) position of EUT transmitted status, it was found that "X axis" position was the worst, then the final test was executed the worst condition and test data were recorded in this report.

3.2. EUT Exercise Software

1. Setup the EUT shown on 3.3.
2. Turn on the power of all equipment.
3. Turn on Wi-Fi function link to AP.
4. EUT run test program.

3.3. Configuration of Test System Details

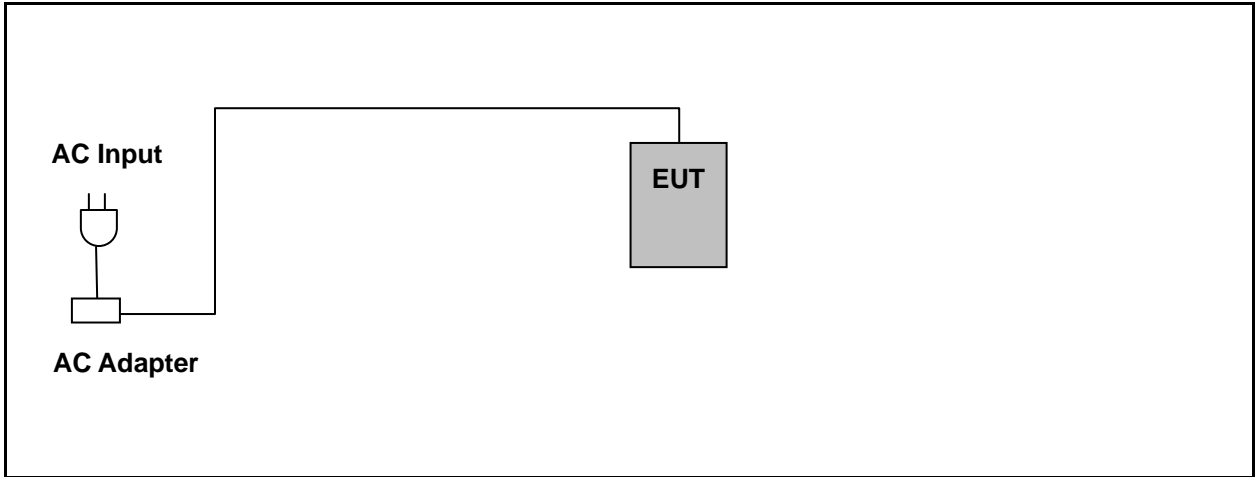

3.4. Test Site Environment

Items	Required (IEC 60068-1)	Actual
Temperature (°C)	15-35	26
Humidity (%RH)	25-75	60
Barometric pressure (mbar)	860-1060	950

4 Conducted Emission Measurement

4.1. Limit

Frequency (MHz)	Quasi-peak	Average
0.15 - 0.5	66 to 56	56 to 46
0.50 - 5.0	56	46
5.0 - 30.0	60	50

4.2. Test Instruments

AC Conducted Emission measurement				
Description	Type No.	Serial No.	Calibrated date	Calibrated until
Test Receiver	ESCS	SB3319	2014.05.16	2015.05.15
LISN	ESH2-Z5	SB3321	2014.05.16	2015.05.15
LISN	ESH2-Z5	SB2604	2014.05.16	2015.05.15
Test Software	ESK1	N/A	N/A	N/A
RF cable(1.0m)	/	S02-1404-09-055	2014.05.11	2015.05.10

Remark: (1) Calibration period 1 year. (2) Calibration period 2 years. (3) Calibration period 3 years.

Note: N.C.R. = No Calibration Request.

4.3. Test Setup

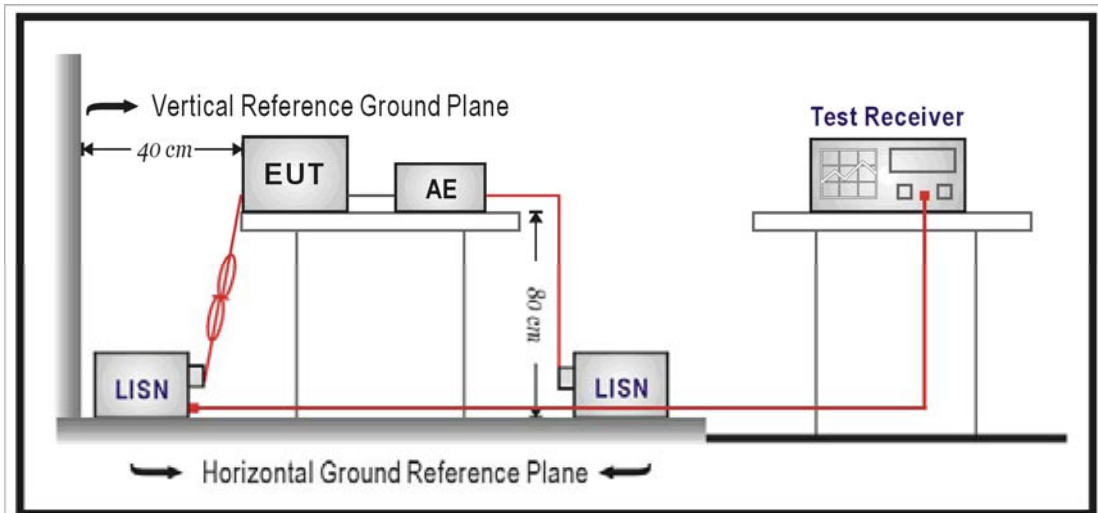



4.4. Test Procedure

The power line conducted emission measurements were performed in a shielded enclosure. The EUT was assembled on a wooden table which is 80 centimeters high, was placed 40 centimeters from the back wall and at least 1 meter from the sidewall.

Power was fed to the EUT from the public utility power grid through a line filter and EMCO Model 3162/2 SH Line Impedance Stabilization Networks (LISN). The LISN housing, measuring instrumentation case, ground plane, etc., were electrically bonded together at the same RF potential. The Spectrum analyzer was connected to the AC line through an isolation transformer. The 50-ohm output of the LISN was connected to the spectrum analyzer directly. Conducted emission levels were in the CISPR quasi-peak detection mode. The analyzer's 6 dB bandwidth was set to 9 KHz. No post-detector video filter was used.

The spectrum was scanned from 150 KHz to 30 MHz. The physical arrangement of the test system and associated cabling was varied (within the scope of arrangements likely to be encountered in actual use) to determine the effect on the unit's emanations in amplitude and frequency. All spurious emission frequencies were observed. The highest emission amplitudes relative to the appropriate limit were measured and have been recorded in paragraph 4.1.



4.5. Test Result

Standard:	FCC Part 15C	Line:	L1
Test item:	Conducted Emission	Power:	AC 120V/60Hz
Model Number:	GAN5.PT156A-B	Temp.(°C)/Hum.(%RH):	25(°C)/59%RH
Mode:	1	Date:	2014-12-13
		Test By:	Fly
Description:			

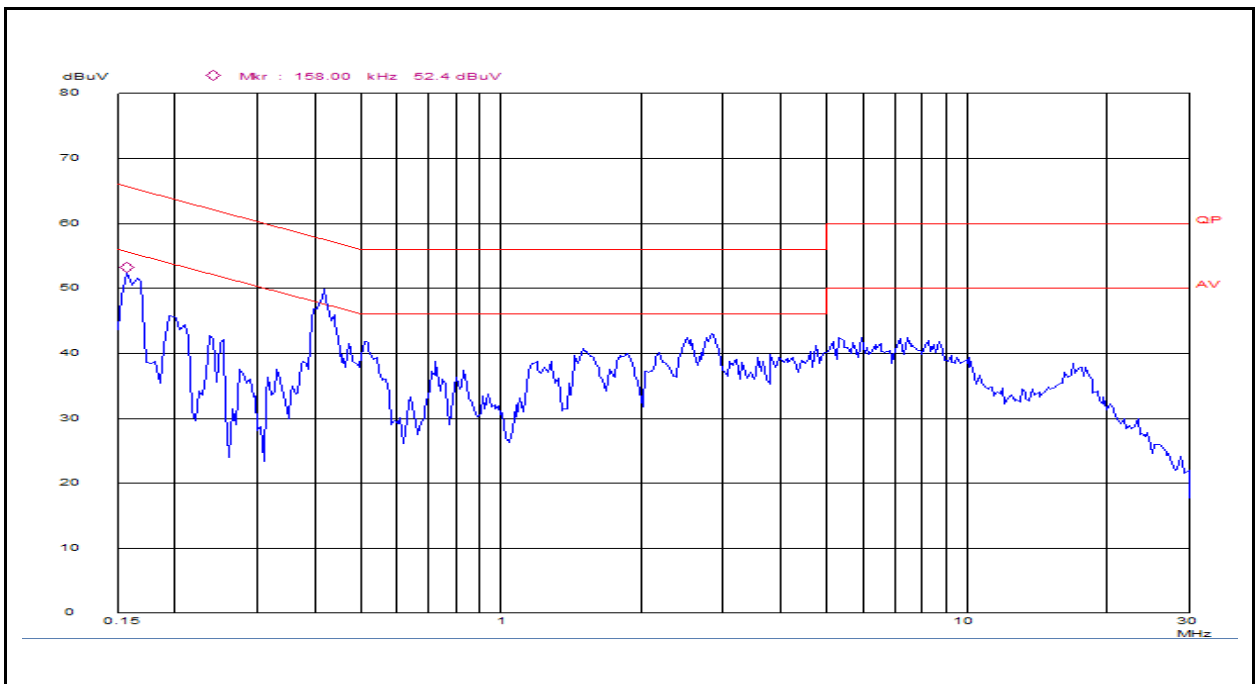

	Frequency (MHz)	Quasi-Peak		Average	
		Emission Level	Limits(dB μ V)	Emission Level	Limits(dB μ V)
Line	0.158	48.0	65.6	36.5	45.6
	0.422	45.8	57.4	38.0	47.4
	2.380	37.8	56.0	30.4	46.0
	/	/	/	/	/
	/	/	/	/	/
	/	/	/	/	/



Standard:	FCC Part 15C	Line:	N
Test item:	Conducted Emission	Power:	AC 120V/60Hz
Model Number:	GAN5.PT156A-B	Temp.(°C)/Hum.(%RH):	25(°C)/59%RH
Mode:	1	Date:	2014-12-13
		Test By:	Fly
Description:			

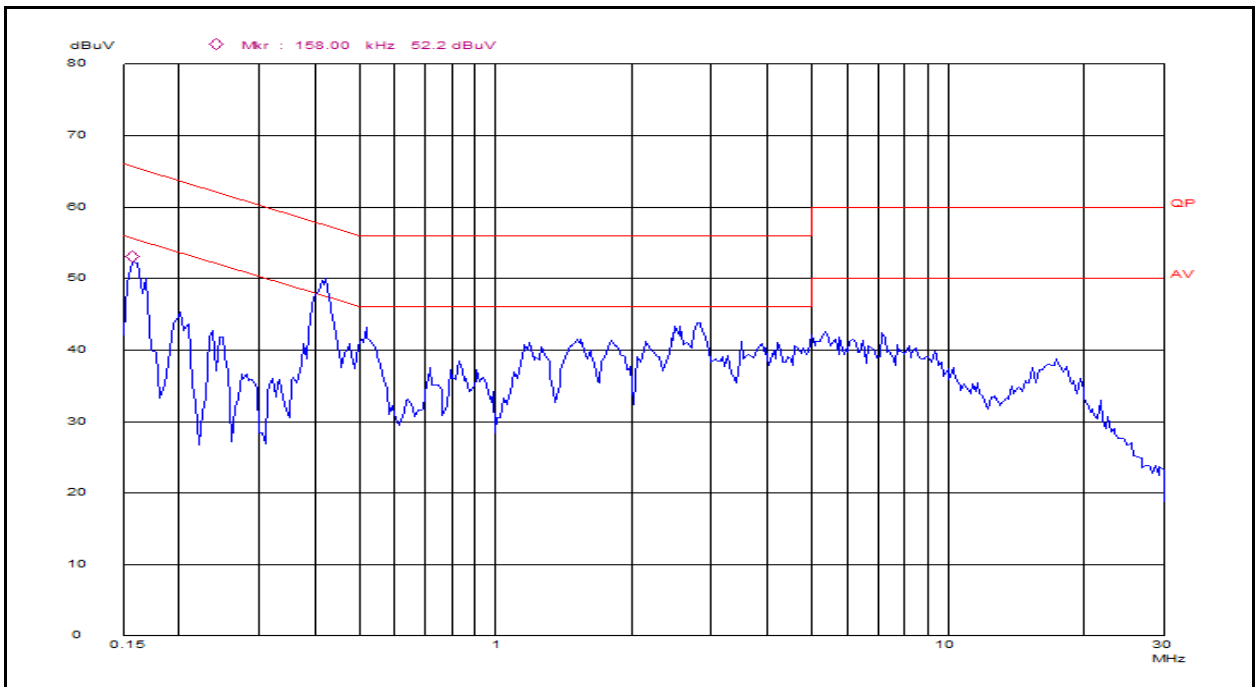

	Frequency (MHz)	Quasi-Peak		Average	
		Emission Level	Limits(dB μ V)	Emission Level	Limits(dB μ V)
Neutral	0.158	47.7	65.6	37.2	45.6
	0.422	45.9	57.4	38.3	47.4
	2.826	38.4	56.0	31.5	46.0
	/	/	/	/	/
	/	/	/	/	/
	/	/	/	/	/



5 Radiated Emission Measurement

5.1. Limit

According to §15.209(a), except as provided elsewhere in this subpart, the emissions from an intentional radiator shall not exceed the field strength levels specified in the following table:

Frequency (MHz)	Field Strength ($\mu\text{V}/\text{m}$ at meter)	Measurement Distance (meters)
0.009 – 0.490	2400 / F (kHz)	300
0.490 – 1.705	24000 / F (kHz)	30
1.705 – 30.0	30	30
30 - 88	100**	3
88-216	150**	3
216-960	200**	3
Above 960	500	3

** Except as provided in paragraph (g), fundamental emissions from intentional radiators operating under this Section shall not be located in the frequency bands 54-72 MHz, 76-88 MHz, 174-216 MHz or 470-806 MHz. However, operation within these frequency bands is permitted under other sections of this Part, e.g., Sections 15.231 and 15.241.

5.2. Test Instruments

Radiated Emission				
Description	Type No.	Serial No.	Calibrated date	Calibrated until
EMI Test Receiver	ESU40	SB8501/09	2014.05.16	2015.05.15
Bilog Antenna	Schwarzbeck	SB8501/04	2014.01.20	2015.01.19
Horn Antenna	HF906	SB3435	2014.01.20	2015.01.19
Amplifier(1-18GHz)	--	SB3435/01	2014.01.20	2015.01.19
Amplifier(18-40GHz)	--	SB3435/02	2014.01.20	2015.01.19
Horn Antenna	AT4560	SB5392/02	2014.05.16	2015.05.15
3m Semi-anechoic chamber	9X6X6	SB3450/01	2014.10.12	2015.10.11
Loop Antenna	6512	29604	2014.09.25	2015.09.24
RF cable(3.5m)	/	S02-1404-09-047	2014.05.11	2015.05.10
RF cable(1.2m)	/	S02-1404-09-052	2014.05.11	2015.05.10
Test Software	EMC32	N/A	N/A	N/A

Remark: (1) Calibration period 1 year. (2) Calibration period 2 years. (3) Calibration period 3 years.

Note: N.C.R. = No Calibration Request.

5.3. Test Setup

9 kHz-30MHz

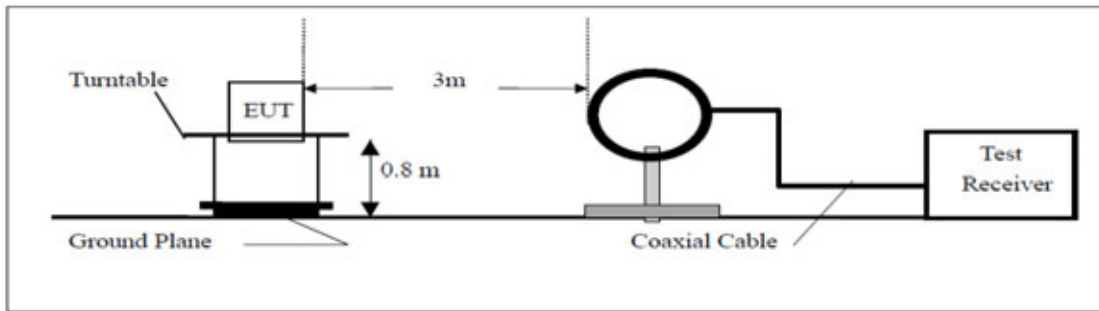

Below 1GHz

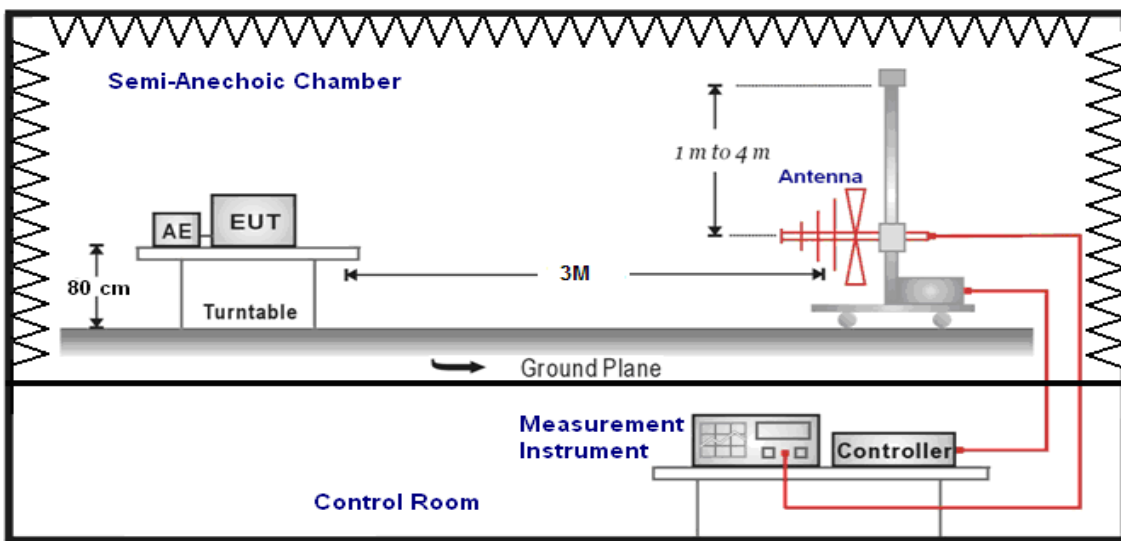

Above 1GHz

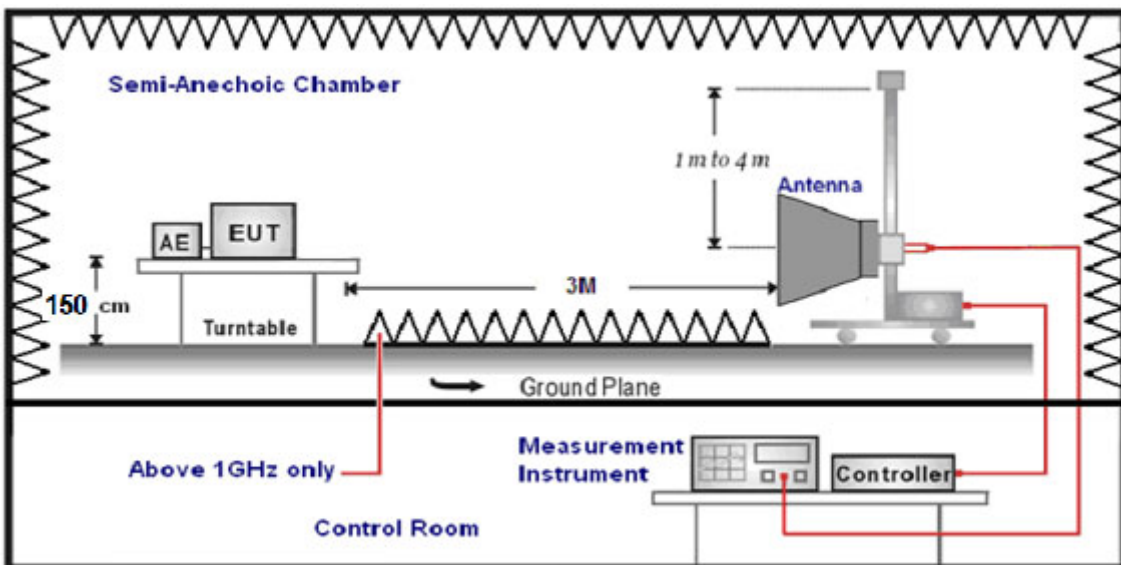



5.4. Test Procedure

The EUT was placed on a turn table which is 0.8m above ground plane for below 1GHz and EUT was placed on a turn table which is 1.5m above ground plane with absorber refer to ANSI C63.10:2013

For measurements below 1 GHz the resolution bandwidth is set to 100 kHz for peak detection measurements or 120 kHz for quasi-peak detection measurements. Peak detection is used unless otherwise noted as quasi-peak.

For measurements above 1 GHz the resolution bandwidth is set to 1 MHz, and then the video bandwidth is set to 1 MHz for peak measurements and 10 Hz for average measurements.

A nonconductive material surrounded the EUT to supporting the EUT for standing on three orthogonal planes. At each condition, the EUT was rotated 360 degrees, and the antenna was raised and lowered from one to four meters to find the maximum emission levels. Measurements were taken using both horizontal and vertical antenna polarization.

Antenna VULB9163 at 3 Meter and Antenna HF906 was used in frequencies 1 – 18 GHz at a distance of 3 meter. Antenna AT4560 was used in frequencies 18 – 40 GHz at a distance of 1 meter. All test results were extrapolated to equivalent signal at 3 meters utilizing an inverse linear distance extrapolation Factor (20dB/decade).

For testing above 1GHz, the emission level of the EUT in peak mode was 20dB lower than average limit (that means the emission level in peak mode also complies with the limit in average mode), then testing will be stopped and peak values of EUT will be reported, otherwise, the emissions will be measured in average mode again and reported.

Appropriate preamplifiers were used for improving sensitivity and precautions were taken to avoid overloading or desensitizing the spectrum analyzer. No post – detector video filters were used in the test.

Set the spectrum analyzer/receiver in the following setting as:

9 KHz to 30MHz (Test Receiver):

RBW=200 Hz/VBW=1 KHz/Sweep=Auto/Dector: QP for 9 KHz to 150 KHz and RBW=9 KHz/VBW=120

KHz/Sweep=Auto/Dector: QP for 150 KHz to 30MHz

30MHz to 1 GHz (Test Receiver):

RBW=120 KHz/VBW=1MHz/Sweep=Auto/Dector: QP

Above 1 GHz (Spectrum analyzer)

- a) Peak values: RBW=1MHz/VBW=3MHz/Sweep=Auto/Dector: Peak
- b) Average values: RBW=1MHz/VBW=10Hz/Sweep=1s/Dector: Peak

The following procedures were used to convert the emission levels measured in decibels referenced to 1 microvolt (dBuV) into field intensity in micro volts pre meter (uV/m).

The actual field intensity in decibels referenced to 1 microvolt in to field intensity in micro colts per meter (dBuV/m).

The actual field is intensity in referenced to 1 microvolt per meter (dBuV/m) is determined by algebraically adding the measured reading in dBuV, the antenna factor (dB), and cable loss (dB) and Subtracting the gain of preamplifier (dB) is auto calculate in spectrum analyzer.

$$(1) \text{ Amplitude (dBuV/m) = FI (dBuV) +AF (dBuV) +CL (dBuV)-Gain (dB)}$$

FI= Reading of the field intensity.

AF= Antenna factor.

CL= Cable loss.

P.S Amplitude is auto calculate in spectrum analyzer.

$$(2) \text{ Actual Amplitude (dBuV/m) = Amplitude (dBuV)-Dis(dB)}$$

The FCC specified emission limits were calculated according the EUT operating frequency and by following linear interpolation equations:

- (a) For fundamental frequency : Transmitter Output < +30dBm



(b) For spurious frequency : Spurious emission limits = fundamental emission limit /10

Data of measurement within this frequency range without mark in the table above means the reading of emissions are attenuated more than 20dB below the permissible limits or the field strength is too small to be measured.

5.5. Test Result

Below 1GHz

Standard:	FCC Part 15C	Test Distance:	3m
Test item:	Radiated Emission	Power:	AC 120V/60Hz
Model Number:	GAN5.PT156A-B	Temp.(°C)/Hum.(%RH):	26(°C)/60%RH
Mode:	1	Date:	2014-12-14
		Test By:	

Description:

Frequency (MHz)	Reading (dBuV)	Correct Factor (dB/m)	Result (dBuV/m)	Limit (dBuV/m)	Margin (dB)	Remark	Ant.Polar. H / V
166.61	65.92	-34.4	31.52	43.5	11.98	QP	H
249.94	69.28	-33.4	35.88	46.0	10.12	QP	H
333.33	70.40	-27.3	43.10	46.0	2.90	QP	H
500.15	69.40	-25.4	44.00	46.0	2.00	QP	H
836.62	60.71	-22.5	38.21	46.0	7.79	QP	H
885.35	61.96	-21.6	40.36	46.0	5.64	QP	H
182.12	66.16	-33.9	32.26	43.5	11.24	QP	V
198.69	71.81	-32.4	39.41	43.5	4.09	QP	V
257.44	54.14	-28.5	25.64	46.0	20.36	QP	V
334.59	67.50	-26.2	41.30	46.0	4.70	QP	V
500.27	69.48	-26.4	43.08	46.0	2.92	QP	V
637.28	64.23	-25.5	38.7	46.0	7.30	QP	V

Note: No emission found between lowest internal used/generated frequencies to 30MHz (9 kHz~30MHz).



Above 1GHz

Standard:	FCC Part 15C			Test Distance:	3m		
Test item:	Radiated Emission			Power:	AC 120V/60Hz		
Model Number:	GAN5.PT156A-B			Temp.(°C)/Hum.(%RH):	26(°C)/60%RH		
Mode:	2			Date:	2014-12-15		
Frequency:	2412MHz			Test By:	Fly		
Frequency (MHz)	Reading (dBuV)	Correct Factor (dB/m)	Result (dBuV/m)	Limit (dBuV/m)	Margin (dB)	Remark	Ant.Polar. H / V
7500.000	40.053	-5.91	45.963	74.00	28.037	peak	H
7500.000	33.311	-5.91	39.221	54.00	14.779	Average	H
7500.000	38.454	-5.91	44.364	74.00	29.636	peak	V
7500.000	31.351	-5.91	37.261	54.00	16.739	Average	V

Standard:	FCC Part 15C			Test Distance:	3m		
Test item:	Radiated Emission			Power:	AC 120V/60Hz		
Model Number:	GAN5.PT156A-B			Temp.(°C)/Hum.(%RH):	26(°C)/60%RH		
Mode:	2			Date:	2014-12-15		
Frequency:	2437MHz			Test By:	Fly		
Frequency (MHz)	Reading (dBuV)	Correct Factor (dB/m)	Result (dBuV/m)	Limit (dBuV/m)	Margin (dB)	Remark	Ant.Polar. H / V
7500.000	41.182	-5.91	47.092	74.00	26.908	peak	H
7500.000	34.001	-5.91	39.911	54.00	14.089	Average	H
7500.000	39.584	-5.91	45.494	74.00	28.506	peak	V
7500.000	31.339	-5.91	37.249	54.00	16.751	Average	V

Standard:	FCC Part 15C			Test Distance:	3m		
Test item:	Radiated Emission			Power:	AC 120V/60Hz		
Model Number:	GAN5.PT156A-B			Temp.(°C)/Hum.(%RH):	26(°C)/60%RH		
Mode:	2			Date:	2014-12-15		
Frequency:	2462MHz			Test By:	Fly		
Frequency (MHz)	Reading (dBuV)	Correct Factor (dB/m)	Result (dBuV/m)	Limit (dBuV/m)	Margin (dB)	Remark	Ant.Polar. H / V
7500.000	40.125	-5.91	46.035	74.00	27.965	peak	H
7500.000	30.705	-5.91	36.615	54.00	17.385	Average	H
7500.000	44.992	-5.91	50.902	74.00	23.098	peak	V
7500.000	34.277	-5.91	40.187	54.00	13.813	Average	V



Standard:	FCC Part 15C			Test Distance:	3m		
Test item:	Radiated Emission			Power:	AC 120V/60Hz		
Model Number:	GAN5.PT156A-B			Temp.(°C)/Hum.(%RH):	26(°C)/60%RH		
Mode:	3			Date:	2014-12-15		
Frequency:	2412MHz			Test By:	Fly		
Frequency (MHz)	Reading (dBuV)	Correct Factor (dB/m)	Result (dBuV/m)	Limit (dBuV/m)	Margin (dB)	Remark	Ant.Polar. H / V
7500.000	39.334	-5.91	45.244	74.00	28.756	peak	H
7500.000	28.126	-5.91	34.036	54.00	19.964	Average	H
7500.000	43.623	-5.91	49.533	74.00	24.467	peak	V
7500.000	31.873	-5.91	37.783	54.00	16.217	Average	V

Standard:	FCC Part 15C			Test Distance:	3m		
Test item:	Radiated Emission			Power:	AC 120V/60Hz		
Model Number:	GAN5.PT156A-B			Temp.(°C)/Hum.(%RH):	26(°C)/60%RH		
Mode:	3			Date:	2014-12-15		
Frequency:	2437MHz			Test By:	Fly		
Frequency (MHz)	Reading (dBuV)	Correct Factor (dB/m)	Result (dBuV/m)	Limit (dBuV/m)	Margin (dB)	Remark	Ant.Polar. H / V
7500.000	40.188	-5.91	46.098	74.00	27.902	peak	H
7500.000	29.612	-5.91	35.522	54.00	18.478	Average	H
7500.000	43.023	-5.91	48.933	74.00	25.067	peak	V
7500.000	31.234	-5.91	37.144	54.00	16.856	Average	V

Standard:	FCC Part 15C			Test Distance:	3m		
Test item:	Radiated Emission			Power:	AC 120V/60Hz		
Model Number:	GAN5.PT156A-B			Temp.(°C)/Hum.(%RH):	26(°C)/60%RH		
Mode:	3			Date:	2014-12-15		
Frequency:	2462MHz			Test By:	Fly		
Frequency (MHz)	Reading (dBuV)	Correct Factor (dB/m)	Result (dBuV/m)	Limit (dBuV/m)	Margin (dB)	Remark	Ant.Polar. H / V
7500.000	38.914	-5.91	44.824	74.00	29.176	peak	H
7500.000	29.116	-5.91	35.026	54.00	18.974	Average	H
7500.000	38.931	-5.91	44.841	74.00	29.159	peak	V
7500.000	29.011	-5.91	34.921	54.00	19.079	Average	V



Standard:	FCC Part 15C			Test Distance:	3m		
Test item:	Radiated Emission			Power:	AC 120V/60Hz		
Model Number:	GAN5.PT156A-B			Temp.(°C)/Hum.(%RH):	26(°C)/60%RH		
Mode:	4			Date:	2014-12-15		
Frequency:	2412MHz			Test By:	Fly		
Frequency (MHz)	Reading (dBuV)	Correct Factor (dB/m)	Result (dBuV/m)	Limit (dBuV/m)	Margin (dB)	Remark	Ant.Polar. H / V
7500.000	39.377	-5.91	45.287	74.00	28.713	peak	H
7500.000	30.869	-5.91	36.779	54.00	17.221	Average	H
7500.000	40.408	-5.91	46.318	74.00	27.682	peak	V
7500.000	31.082	-5.91	36.992	54.00	17.008	Average	V

Standard:	FCC Part 15C			Test Distance:	3m		
Test item:	Radiated Emission			Power:	AC 120V/60Hz		
Model Number:	GAN5.PT156A-B			Temp.(°C)/Hum.(%RH):	26(°C)/60%RH		
Mode:	4			Date:	2014-12-15		
Frequency:	2437MHz			Test By:	Fly		
Frequency (MHz)	Reading (dBuV)	Correct Factor (dB/m)	Result (dBuV/m)	Limit (dBuV/m)	Margin (dB)	Remark	Ant.Polar. H / V
7500.000	40.162	-5.91	46.072	74.00	27.928	peak	H
7500.000	32.119	-5.91	38.029	54.00	15.971	Average	H
7500.000	40.49	-5.91	46.400	74.00	27.6	peak	V
7500.000	31.869	-5.91	37.779	54.00	16.221	Average	V

Standard:	FCC Part 15C			Test Distance:	3m		
Test item:	Radiated Emission			Power:	AC 120V/60Hz		
Model Number:	GAN5.PT156A-B			Temp.(°C)/Hum.(%RH):	26(°C)/60%RH		
Mode:	4			Date:	2014-12-15		
Frequency:	2462MHz			Test By:	Fly		
Frequency (MHz)	Reading (dBuV)	Correct Factor (dB/m)	Result (dBuV/m)	Limit (dBuV/m)	Margin (dB)	Remark	Ant.Polar. H / V
7500.000	38.736	-5.91	44.646	74.00	29.354	peak	H
7500.000	32.324	-5.91	38.234	54.00	15.766	Average	H
7500.000	40.924	-5.91	46.834	74.00	27.166	peak	V
7500.000	33.315	-5.91	39.225	54.00	14.775	Average	V



Standard:	FCC Part 15C			Test Distance:	3m		
Test item:	Radiated Emission			Power:	AC 120V/60Hz		
Model Number:	GAN5.PT156A-B			Temp.(°C)/Hum.(%RH):	26(°C)/60%RH		
Mode:	5			Date:	2014-12-15		
Frequency:	2422MHz			Test By:	Fly		
Frequency (MHz)	Reading (dBuV)	Correct Factor (dB/m)	Result (dBuV/m)	Limit (dBuV/m)	Margin (dB)	Remark	Ant.Polar. H / V
7500.000	37.709	-5.91	43.619	74.00	30.381	peak	H
7500.000	28.677	-5.91	34.587	54.00	19.413	Average	H
7500.000	38.05	-5.91	43.960	74.00	30.04	peak	V
7500.000	30.345	-5.91	36.255	54.00	17.745	Average	V

Standard:	FCC Part 15C			Test Distance:	3m		
Test item:	Radiated Emission			Power:	AC 120V/60Hz		
Model Number:	GAN5.PT156A-B			Temp.(°C)/Hum.(%RH):	26(°C)/60%RH		
Mode:	5			Date:	2014-12-15		
Frequency:	2437MHz			Test By:	Fly		
Frequency (MHz)	Reading (dBuV)	Correct Factor (dB/m)	Result (dBuV/m)	Limit (dBuV/m)	Margin (dB)	Remark	Ant.Polar. H / V
7500.000	38.012	-5.91	43.922	74.00	30.078	peak	H
7500.000	30.337	-5.91	36.247	54.00	17.753	Average	H
7500.000	37.821	-5.91	43.731	74.00	30.269	peak	V
7500.000	29.427	-5.91	35.337	54.00	18.663	Average	V

Standard:	FCC Part 15C			Test Distance:	3m		
Test item:	Radiated Emission			Power:	AC 120V/60Hz		
Model Number:	GAN5.PT156A-B			Temp.(°C)/Hum.(%RH):	26(°C)/60%RH		
Mode:	5			Date:	2014-12-15		
Frequency:	2452MHz			Test By:	Fly		
Frequency (MHz)	Reading (dBuV)	Correct Factor (dB/m)	Result (dBuV/m)	Limit (dBuV/m)	Margin (dB)	Remark	Ant.Polar. H / V
7500.000	38.962	-5.91	44.872	74.00	29.128	peak	H
7500.000	30.217	-5.91	36.127	54.00	17.873	Average	H
7500.000	39.215	-5.91	45.125	74.00	28.875	peak	V
7500.000	31.081	-5.91	36.991	54.00	17.009	Average	V

6 Maximum Conducted Output Power Measurement

6.1. Limit

For systems using digital modulation in the 2400-2483.5MHz, the limit for peak output power is 30dBm.

6.2. Test Setup

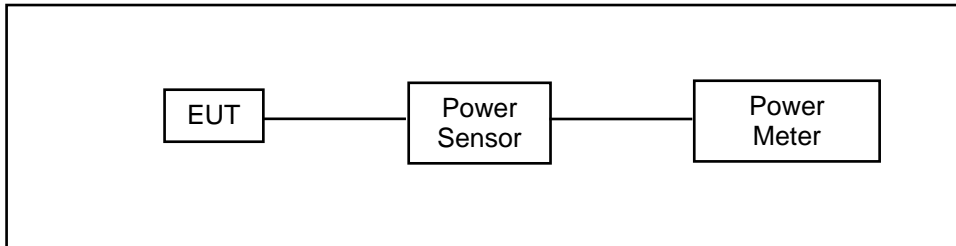

6.3. Test Instruments

Equipment	Manufacturer	Model Number	Serial Number	Cal. Date	Remark
Power Sensor	Anritsu	MA2411B	1126022	08/21/2014	(1)
Power Meter	Anritsu	ML2495A	1135009	08/21/2014	(1)
Test Site	ATL	TE05	TE05	N.C.R.	-----

Remark: (1) Calibration period 1 year. (2) Calibration period 2 years. (3) Calibration period 3 years.

Note: N.C.R. = No Calibration Request.

6.4. Test Procedure

The tests below are run with the EUT's transmitter set at high power in TX mode. The EUT is needed to force selection of output power level and channel number. While testing, EUT was set to transmit continuously. Remove the Subjective device's antenna and connect the RF output port to power sensor. The maximum peak output power shall not exceed 1 watt.

Use a direct connection between the antenna port of transmitter and the power sensor, for prevent the power sensor input attenuation 40-50 dB. Set the RBW Bandwidth of the emission or use a channel power meter mode.

For antennas with gains of 6 dBi or less, maximum allowed transmitter output is 1 watt (+30 dBm). For antennas with gains greater than 6 dBi, transmitter output level must be decreased by an amount equal to (GAIN - 6)/3 dBm.

The antenna port of the EUT was connected to the input of a power sensor. Power was read directly and cable loss correction was added to the reading to obtain power at the EUT antenna terminals.



6.5. Test Result

Model Number	GAN5.PT156A-B		
Test Item	Maximum Conducted Output Power		
Test Mode	Mode 2: IEEE 802.11b Link Mode		
Date of Test	2014-12-15	Test Site	TE05
Frequency (MHz)	Peak Power (dBm)		Limit (dBm)
	Antenna 0	Antenna 1	
2412	19.49	N/A	< 30
2437	19.94	N/A	< 30
2462	19.13	N/A	< 30

Model Number	GAN5.PT156A-B		
Test Item	Maximum Conducted Output Power		
Test Mode	Mode 3: IEEE 802.11g Link Mode		
Date of Test	2014-12-15	Test Site	TE05
Frequency (MHz)	Peak Power (dBm)		Limit (dBm)
	Antenna 0	Antenna 1	
2412	23.14	24.38	< 30
2437	24.21	24.69	< 30
2462	22.51	23.22	< 30

Model Number	GAN5.PT156A-B			
Test Item	Maximum Conducted Output Power			
Test Mode	Mode 4: IEEE 802.11n 2.4GHz 20MHz Link Mode			
Date of Test	2014-12-15	Test Site	TE05	
Frequency (MHz)	Peak Power (dBm)			Limit (dBm)
	Antenna 0	Antenna 1	Antenna 0+Antenna 1	
2412	17.36	16.45	19.94	< 30
2437	20.29	20.15	23.23	< 30
2462	16.29	17.23	19.80	< 30

Model Number	GAN5.PT156A-B			
Test Item	Maximum Conducted Output Power			
Test Mode	Mode 5: IEEE 802.11n 2.4GHz 40MHz Link Mode			
Date of Test	2014-12-15	Test Site	TE05	
Frequency (MHz)	Peak Power (dBm)			Limit (dBm)
	Antenna 0	Antenna 1	Antenna 0+Antenna 1	
2422	20.58	21.26	23.94	< 30
2437	20.72	21.11	23.93	< 30
2452	20.69	21.76	24.27	< 30

7 6dB RF Bandwidth and 99 % Occupied Bandwidth Measurement

7.1. Limit

6dB RF Bandwidth: Systems using digital modulation techniques may operate in the 2400–2483.5 MHz bands. The minimum 6 dB band-width shall be at least 500 kHz.

99 % Occupied Bandwidth: N/A

7.2. Test Setup

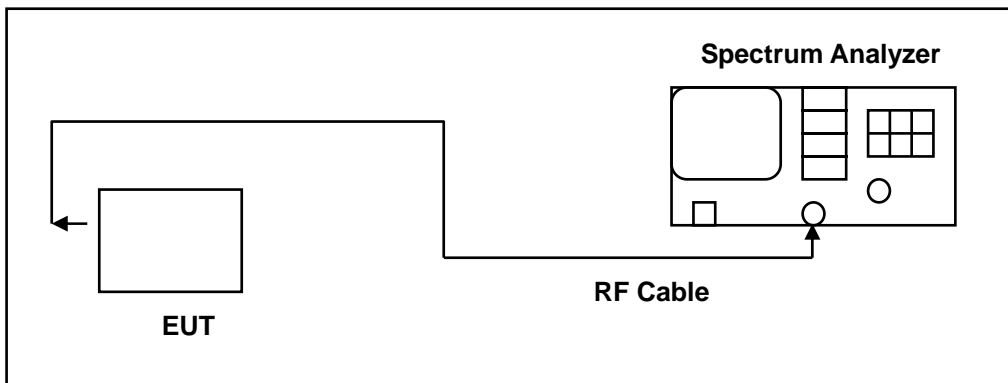

7.3. Test Instruments

Equipment	Manufacturer	Model Number	Serial Number	Cal. Date	Remark
Spectrum Analyzer	Agilent	N9020A	MY53420615	05/13/2014	(2)
Test Site	ATL	TE05	TE05	N.C.R.	-----

dRemark: (1) Calibration period 1 year. (2) Calibration period 2 years. (3) Calibration period 3 years.

Note: N.C.R. = No Calibration Request.

7.4. Test Procedure

The EUT was setup to ANSI C63.4, 2009; tested to DTS test procedure of KDB558074D01 for compliance to FCC 47CFR 15.247 requirements.

6dB RF Bandwidth: The antenna port of the EUT was connected to the input of a spectrum analyzer. Analyzer RES BW was set to 100 kHz. For each RF output channel investigated, the spectrum analyzer center frequency was set to the channel carrier. A peak output reading was taken, a DISPLAY line was drawn 6 dB lower than peak level. The 6 dB bandwidth was determined from where the channel output spectrum intersected the display line.

The test was performed at 3 channels (Channel low, middle, high)

99 % Occupied Bandwidth: The transmitter shall be operated at its maximum carrier power measured under normal test conditions.

The video bandwidth shall be set to 3 times the resolution bandwidth. Video averaging is not permitted. Where practical, a sampling detector shall be used since a peak or, peak hold, may produce a wider bandwidth than actual.

The trace data points are recovered and are directly summed in linear terms. The recovered amplitude data points, beginning at the lowest frequency, are placed in a running sum until 0.5% of the total is reached and that frequency recorded. The process is repeated for the highest frequency data points. This frequency is recorded.



7.5. Test Result

Model Number	GAN5.PT156A-B		
Test Item	6dB RF Bandwidth and 99 % Occupied Bandwidth		
Test Mode	Mode 2: IEEE 802.11b Link Mode		
Date of Test	2014-12-23	Test Site	TE05
Frequency (MHz)	6dB RF Bandwidth (MHz)	99 % Occupied Bandwidth (MHz)	6dB RF Bandwidth Limit (MHz)
2412	7.966	10.127	> 0.500
2437	7.952	10.115	> 0.500
2462	8.035	10.149	> 0.500

Model Number	GAN5.PT156A-B		
Test Item	6dB RF Bandwidth and 99 % Occupied Bandwidth		
Test Mode	Mode 3: IEEE 802.11g Link Mode		
Date of Test	2014-12-23	Test Site	TE05
Frequency (MHz)	6dB RF Bandwidth (MHz)	99 % Occupied Bandwidth (MHz)	6dB RF Bandwidth Limit (MHz)
2412	16.34	16.287	> 0.500
2437	16.37	16.306	> 0.500
2462	15.41	16.308	> 0.500

Model Number	GAN5.PT156A-B		
Test Item	6dB RF Bandwidth and 99 % Occupied Bandwidth		
Test Mode	Mode 4: IEEE 802.11n 2.4GHz 20MHz Link Mode		
Date of Test	2014-12-23	Test Site	TE05
Frequency (MHz)	6dB RF Bandwidth (MHz)	99 % Occupied Bandwidth (MHz)	6dB RF Bandwidth Limit (MHz)
2412	17.54	17.460	> 0.500
2437	17.32	17.470	> 0.500
2462	15.71	17.427	> 0.500

Model Number	GAN5.PT156A-B		
Test Item	6dB RF Bandwidth and 99 % Occupied Bandwidth		
Test Mode	Mode 5: IEEE 802.11n 2.4GHz 40MHz Link Mode		
Date of Test	2014-12-23	Test Site	TE05
Frequency (MHz)	6dB RF Bandwidth (MHz)	99 % Occupied Bandwidth (MHz)	6dB RF Bandwidth Limit (MHz)
2422	36.43	36.177	> 0.500
2437	36.45	36.163	> 0.500
2452	36.38	36.178	> 0.500



7.6. Test Graphs

6dB RF Bandwidth & 99 % Occupied Bandwidth

Mode 2: IEEE 802.11b Link Mode

2412	<p>Agilent Spectrum Analyzer - Occupied BW</p> <p>Center Freq 2.41200000 GHz</p> <p>Ref Offset 7 dB Ref 20.00 dBm</p> <p>Center 2.412 GHz #Res BW 100 kHz</p> <p>Occupied Bandwidth 10.127 MHz</p> <p>Total Power 17.2 dBm</p> <p>Transmit Freq Error 10.412 kHz</p> <p>x dB Bandwidth 7.966 MHz</p> <p>OBW Power 99.00 %</p> <p>-6.00 dB</p>
2437	<p>Agilent Spectrum Analyzer - Occupied BW</p> <p>Center Freq 2.43700000 GHz</p> <p>Ref Offset 7 dB Ref 20.00 dBm</p> <p>Center 2.437 GHz #Res BW 100 kHz</p> <p>Occupied Bandwidth 10.115 MHz</p> <p>Total Power 17.5 dBm</p> <p>Transmit Freq Error 39.295 kHz</p> <p>x dB Bandwidth 7.952 MHz</p> <p>OBW Power 99.00 %</p> <p>-6.00 dB</p>
2462	<p>Agilent Spectrum Analyzer - Occupied BW</p> <p>Center Freq 2.46200000 GHz</p> <p>Ref Offset 7 dB Ref 20.00 dBm</p> <p>Center 2.462 GHz #Res BW 100 kHz</p> <p>Occupied Bandwidth 10.149 MHz</p> <p>Total Power 15.4 dBm</p> <p>Transmit Freq Error 57.966 kHz</p> <p>x dB Bandwidth 8.035 MHz</p> <p>OBW Power 99.00 %</p> <p>-6.00 dB</p>



Mode 3: IEEE 802.11g Link Mode

2412



2437



2462

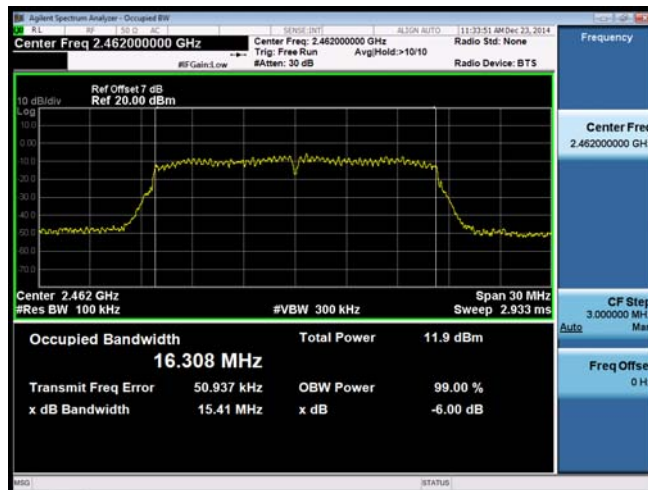



Mode 4: IEEE 802.11n 2.4GHz 20MHz Link Mode

2412



2437



2462





Mode 5: IEEE 802.11n 2.4GHz 40MHz Link Mode

2422



2437

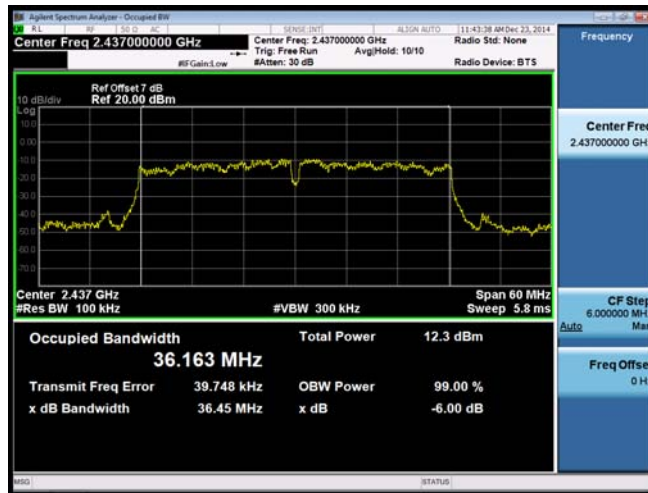

2452

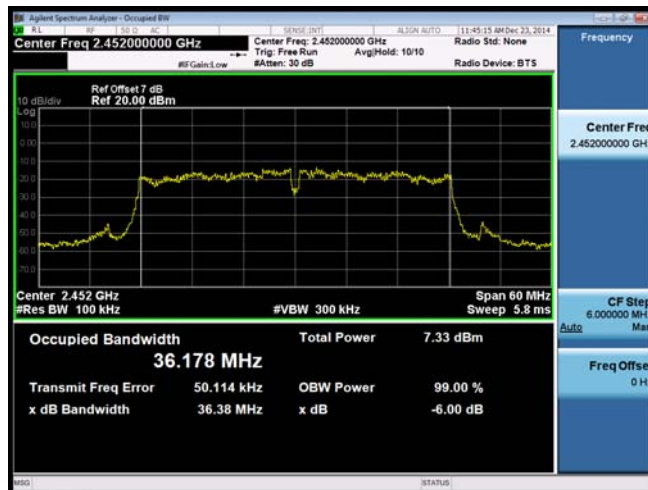

8 Maximum Power Density Measurement

8.1. Limit

For digitally modulated systems, the power spectral density conducted from the intentional radiator to the antenna shall not be greater than 8 dBm in any 3 kHz band during any time interval of continuous transmission.

8.2. Test Setup

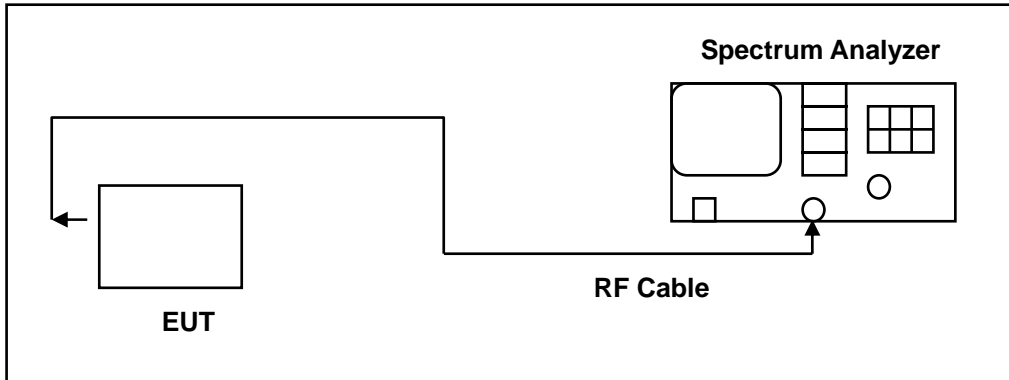

8.3. Test Instruments

Equipment	Manufacturer	Model Number	Serial Number	Cal. Date	Remark
Spectrum Analyzer	Agilent	N9020A	MY53420615	05/13/2014	(2)
Test Site	ATL	TE05	TE05	N.C.R.	-----

Remark: (1) Calibration period 1 year. (2) Calibration period 2 years. (3) Calibration period 3 years.

Note: N.C.R. = No Calibration Request.

8.4. Test Procedure

The EUT was setup to ANSI C63.4, 2009; tested to DTS test procedure of KDB558074D01 for compliance to FCC 47CFR 15.247 requirements.

1. Set analyzer center frequency to DTS channel center frequency.
2. Set the span to 1.5 times the DTS bandwidth.
3. Set the RBW to: $3 \text{ kHz} \leq \text{RBW} \leq 100 \text{ kHz}$.
4. Set the VBW $\geq 3 \times \text{RBW}$.
5. Detector = peak.
6. Sweep time = auto couple.
7. Trace mode = max hold.
8. Allow trace to fully stabilize.
9. Use the peak marker function to determine the maximum amplitude level within the RBW.
10. If measured value exceeds limit, reduce RBW (no less than 3 kHz) and repeat.



8.5. Test Result

Model Number	GAN5.PT156A-B		
Test Item	Maximum Power Density		
Test Mode	Mode 2: IEEE 802.11b Link Mode		
Date of Test	2014-12-23	Test Site	TE05
Frequency (MHz)	Reading (dBm/100KHz)		Limit (dBm/3kHz)
	Antenna 0	Antenna 1	
2412	7.504	N/A	< 8
2437	7.672	N/A	< 8
2462	5.454	N/A	< 8

Model Number	GAN5.PT156A-B		
Test Item	Maximum Power Density		
Test Mode	Mode 3: IEEE 802.11g Link Mode		
Date of Test	2014-12-23	Test Site	TE05
Frequency (MHz)	Reading (dBm/100KHz)		Limit (dBm/3kHz)
	Antenna 0	Antenna 1	
2412	1.235	1.301	< 8
2437	3.272	2.966	< 8
2462	0.140	0.138	< 8

Model Number	GAN5.PT156A-B			
Test Item	Maximum Power Density			
Test Mode	Mode 4: IEEE 802.11n 2.4GHz 20MHz Link Mode			
Date of Test	2014-12-23	Test Site	TE05	
Frequency (MHz)	Reading (dBm/100KHz)			Limit (dBm/3kHz)
	Antenna 0	Antenna 1	Antenna 0+ Antenna 1	
2412	-4.303	-4.226	-1.25	< 8
2437	4.240	4.315	7.29	< 8
2462	-2.905	-2.087	0.53	< 8





Model Number	GAN5.PT156A-B			
Test Item	Maximum Power Density			
Test Mode	Mode 5: IEEE 802.11n 2.4GHz 40MHz Link Mode			
Date of Test	2014-12-23	Test Site		TE05
Frequency (MHz)	Reading (dBm/100kHz)			Limit (dBm/3kHz)
	Antenna 0	Antenna 1	Antenna 0+ Antenna 1	
2422	-6.974	-6.882	-3.92	< 8
2437	-1.596	-1.589	1.42	< 8
2452	-6.603	-5.997	-3.28	< 8

Note: 1.The EUT incorporates a MIMO function when operation in 802.11n mode. Physically, the EUT provides two completed transmitters. All transmit signal are completely uncorrelated. And the relevant measured result has the offset with cable loss already.

2.According to KDB558074 D01 DTS Meas Guidance v03r02, section 10.2, c & j, A 3kHz to 100kHz RBW can be used for the PSD measurement, and we choose the 100kHz RBW for it is the worst case.



8.6. Test Graphs

Mode 2: IEEE 802.11b Link Mode	
2412	
2437	
2462	



Mode 3: IEEE 802.11g Link Mode

2412



2437



2462

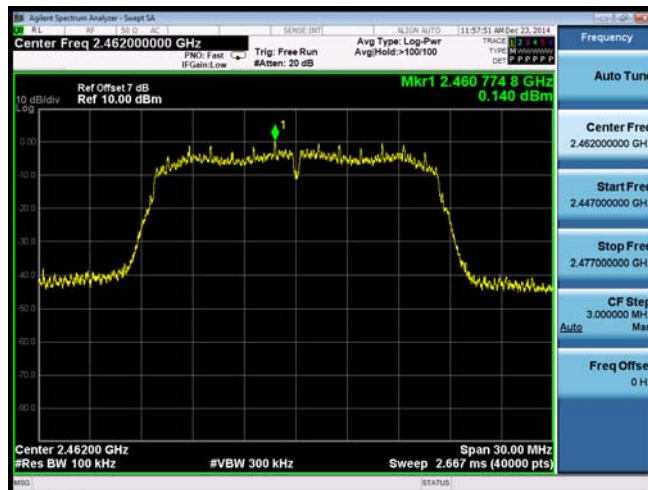



Mode 4: IEEE 802.11n 2.4GHz 20MHz Link Mode

2412



2437



2462

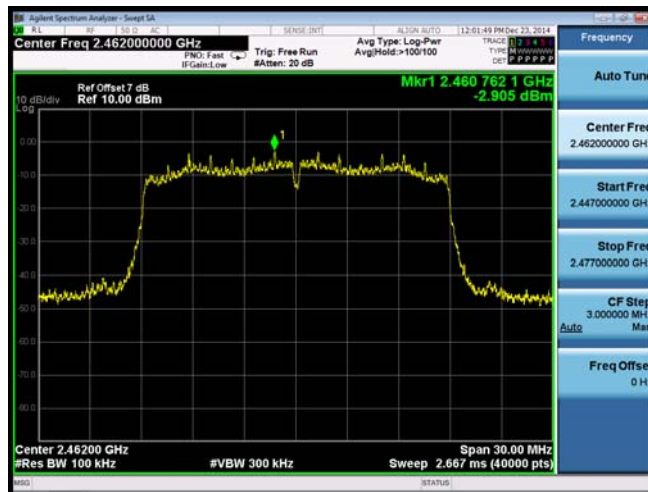



Mode 5: IEEE 802.11n 2.4GHz 40MHz Link Mode

2422



2437

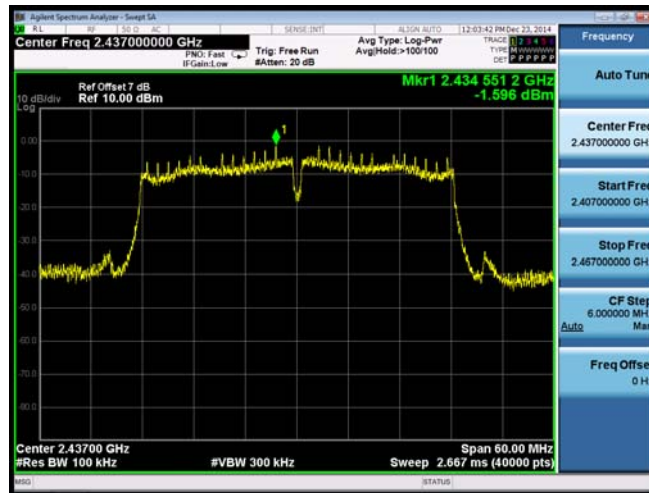

2452



9 Out of Band Conducted Emissions Measurement

9.1. Limit

In any 100 kHz bandwidth outside the frequency band in which the spread spectrum or digitally modulated intentional radiator is operating, the radio frequency power that is produced by the intentional radiator shall be at least 20 dB below that in the 100 kHz bandwidth within the band that contains the highest level of the desired power

9.2. Test Setup

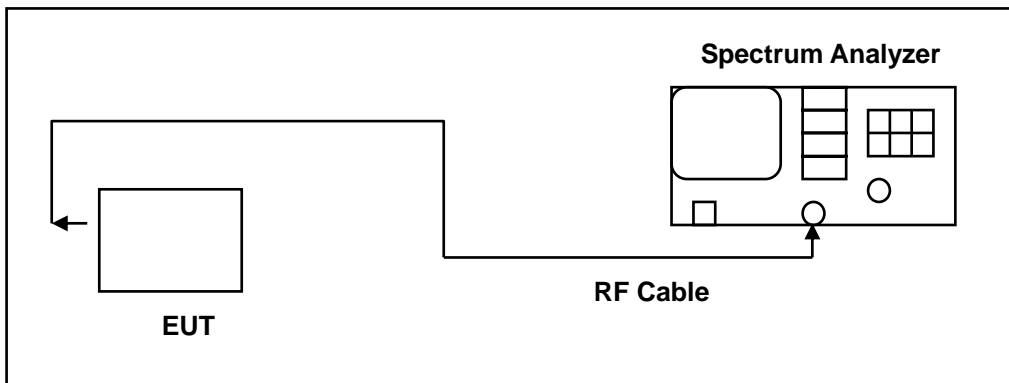

9.3. Test Instruments

Equipment	Manufacturer	Model Number	Serial Number	Cal. Date	Remark
Spectrum Analyzer	Agilent	N9020A	MY53420615	05/13/2014	(2)
Spectrum Analyzer	Agilent	E4408B	MY45107753	07/24/2014	(1)
Test Site	ATL	TE05	TE05	N.C.R.	-----

Remark: (1) Calibration period 1 year. (2) Calibration period 2 years. (3) Calibration period 3 years.

Note: N.C.R. = No Calibration Request.

9.4. Test Procedure

In any 100 kHz bandwidth outside the EUT pass band, the RF power produced by the modulation products of the spreading sequence, the information sequence, and the carrier frequency shall be at least 20 dB below that of the maximum in-band 100 kHz emission, antenna output of the EUT was coupled directly to spectrum analyzer; if an external attenuator and/or cable was used, these losses are compensated for with the analyzer OFFSET function.

All other types of emissions from the EUT shall meet the general limits for radiated frequencies outside the pass band.

The test was performed at 3 channels.



9.5. Test Graphs

Reference level

Mode 2: IEEE 802.11b Link Mode

2412



2437



2462





Mode 3: IEEE 802.11g Link Mode

2412



2437



2462





Mode 4: IEEE 802.11n 2.4GHz 20MHz Link Mode

2412

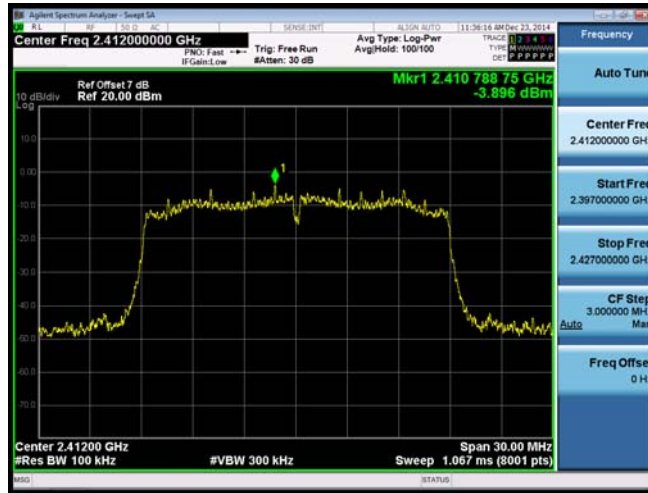

2437



2462





Mode 5: IEEE 802.11n 2.4GHz 40MHz Link Mode

2422

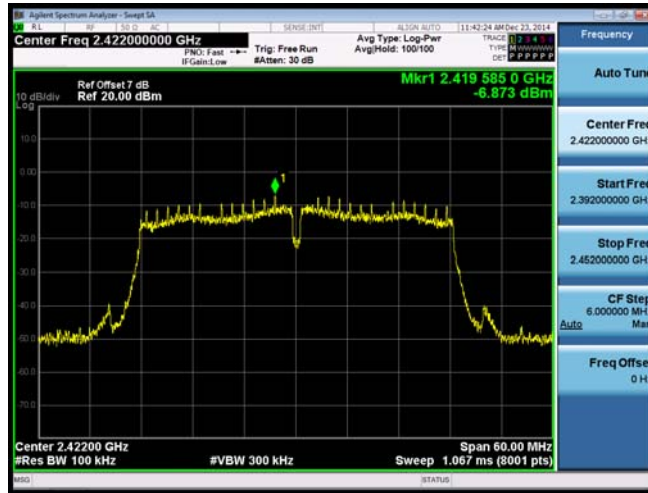

2437



2452





Out of Band Conducted Emissions

Mode 2: IEEE 802.11b Link Mode-2412

9kHz-30MHz

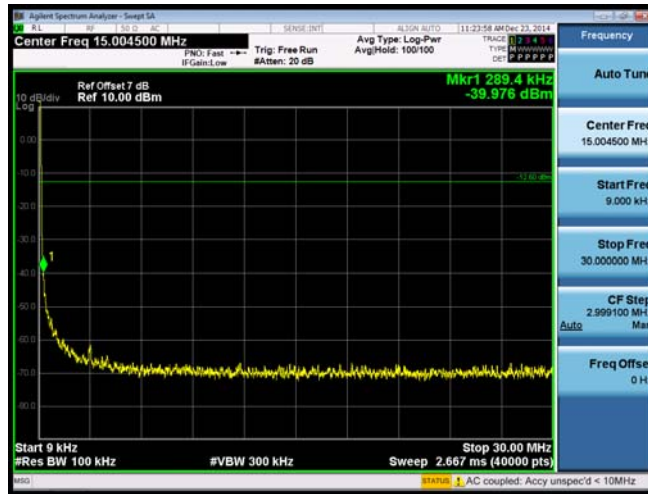

30MHz-1GHz

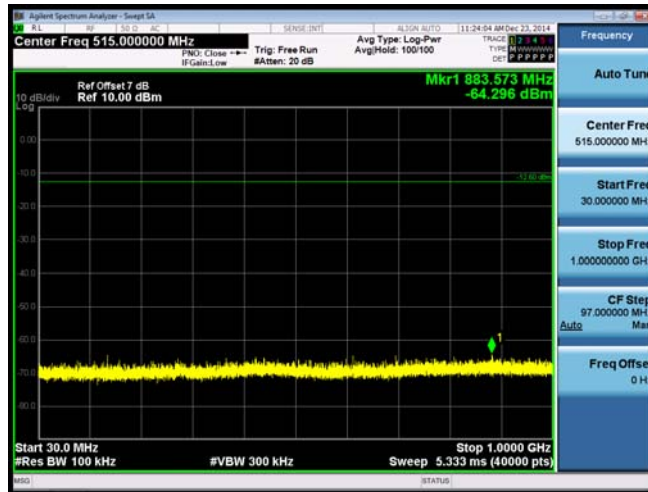

1GHz-2.4GHz

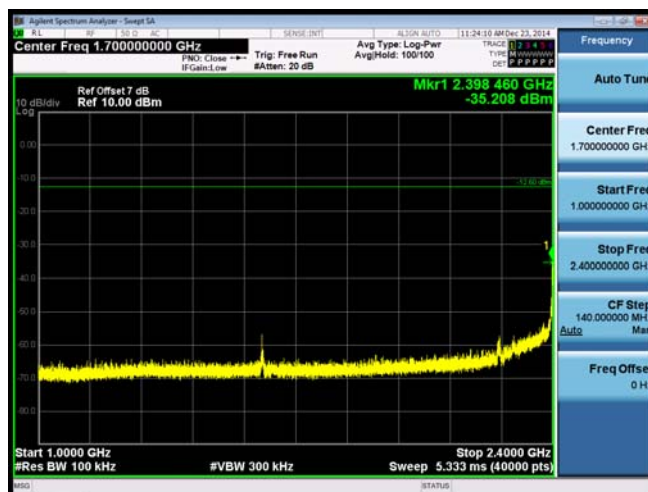

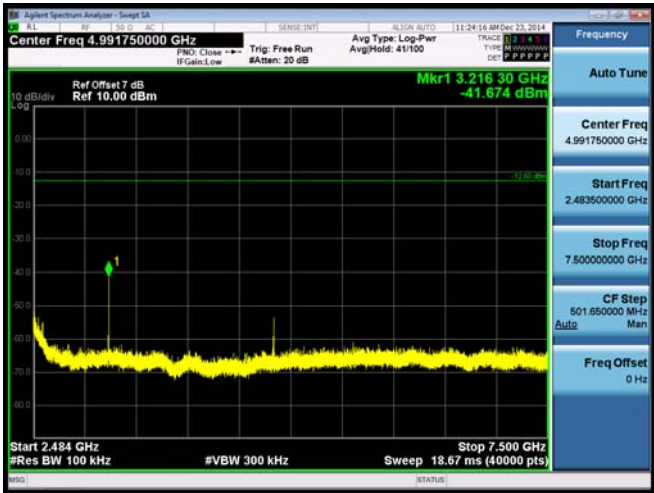
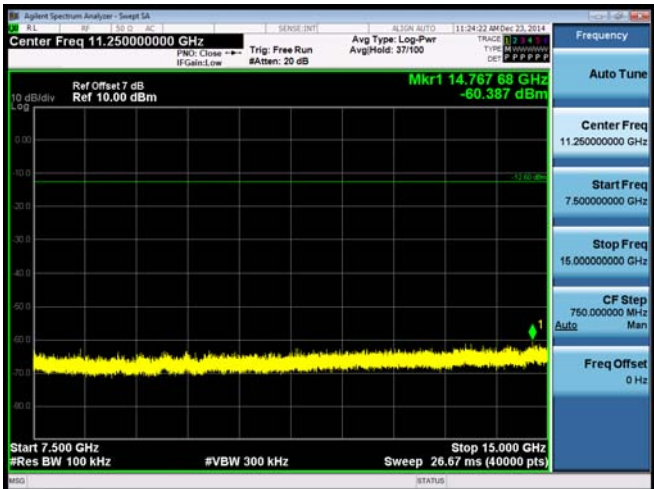
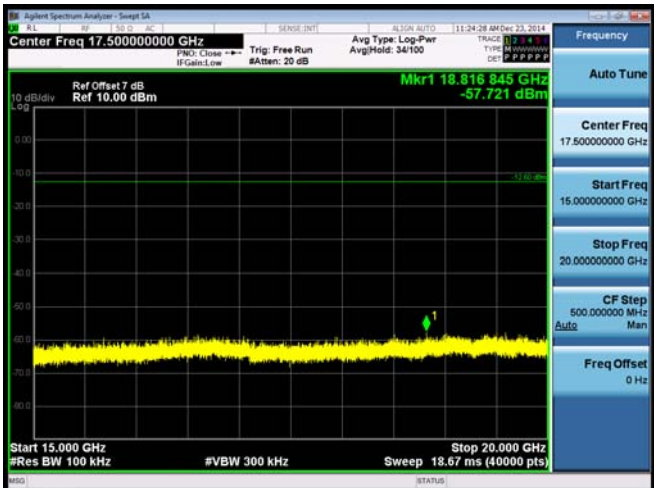

2.4835GHz-7.5GHz	
Mode 2: IEEE 802.11b Link Mode-2412	
7.5GHz-15GHz	
15GHz-20GHz	

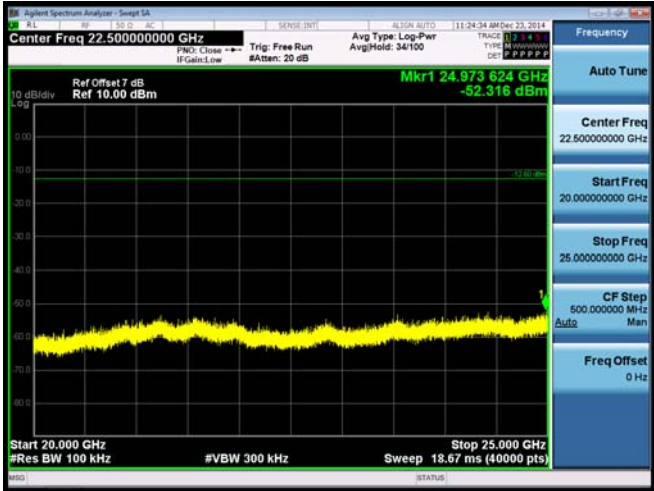
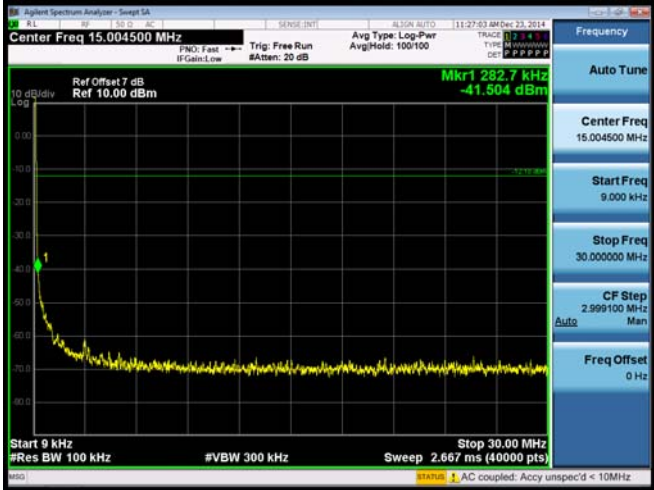
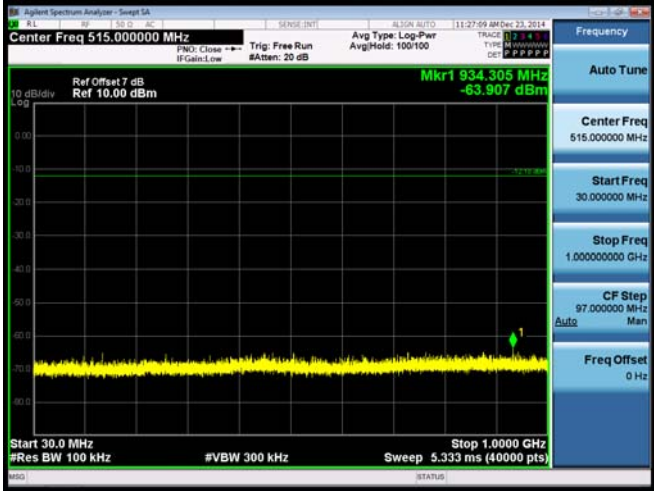

20GHz-25GHz	
Mode 2: IEEE 802.11b Link Mode-2437	
9kHz-30MHz	
30MHz-1GHz	

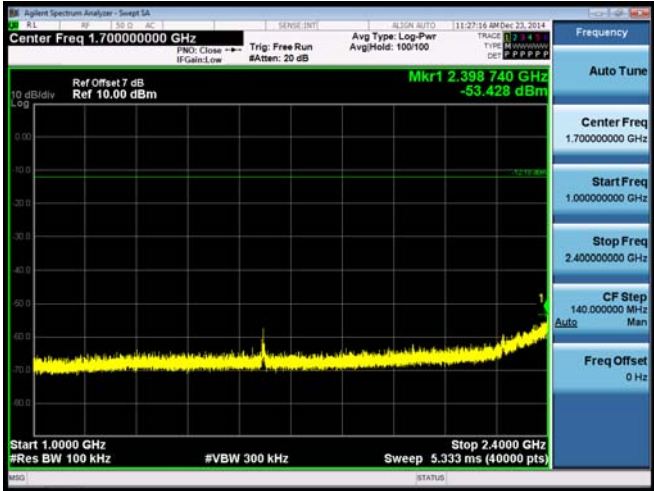
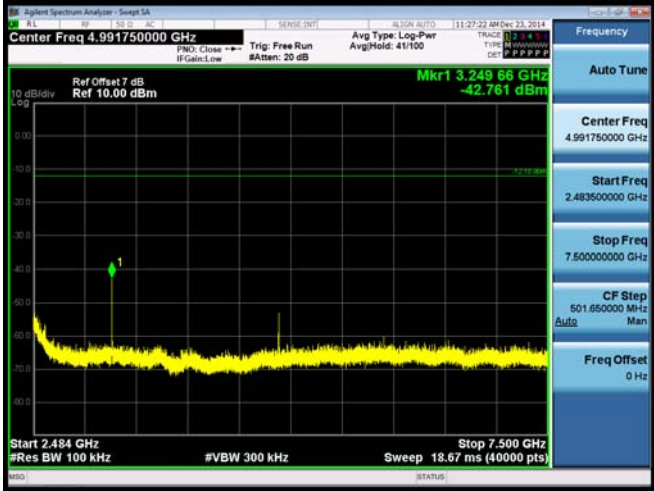
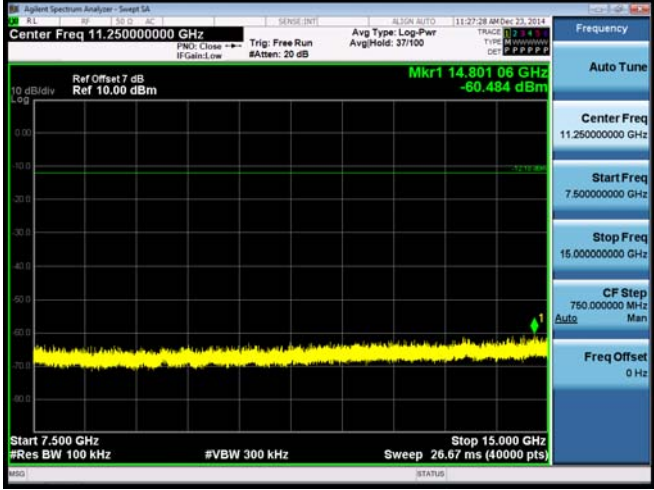

1GHz-2.4GHz	
2.4835GHz-7.5GHz	
Mode 2: IEEE 802.11b Link Mode-2437	
7.5GHz-15GHz	



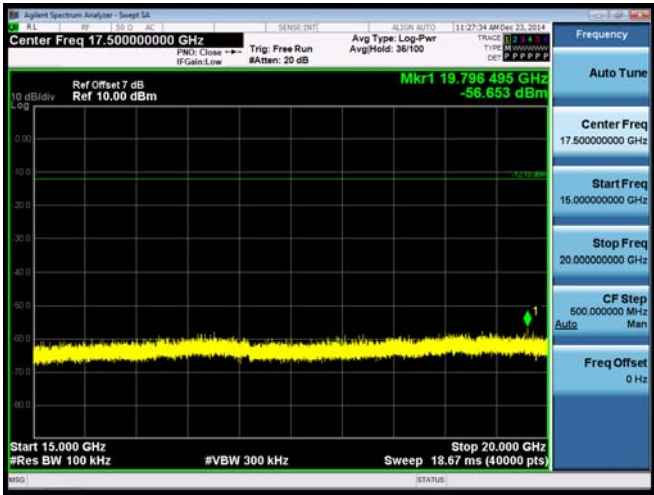
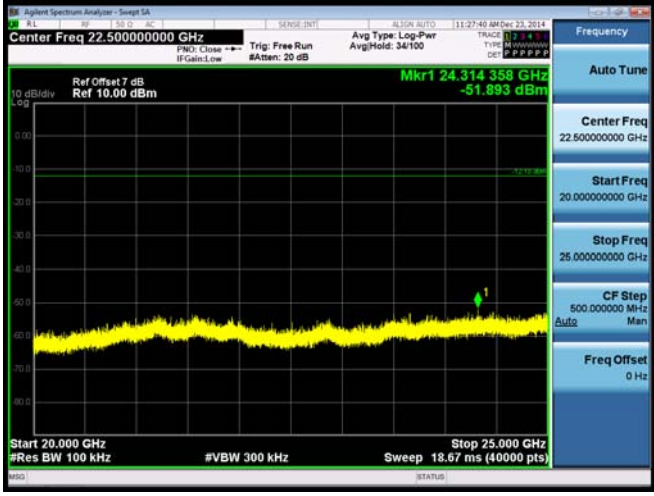
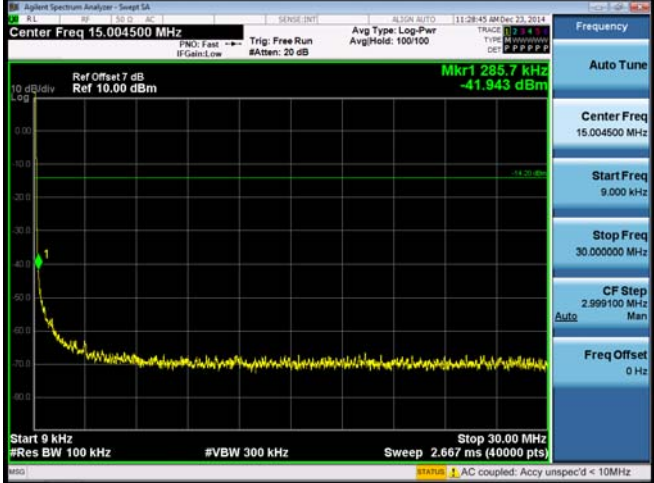

15GHz-20GHz	
20GHz-25GHz	
Mode 2: IEEE 802.11b Link Mode-2462	
9KHz-30MHz	

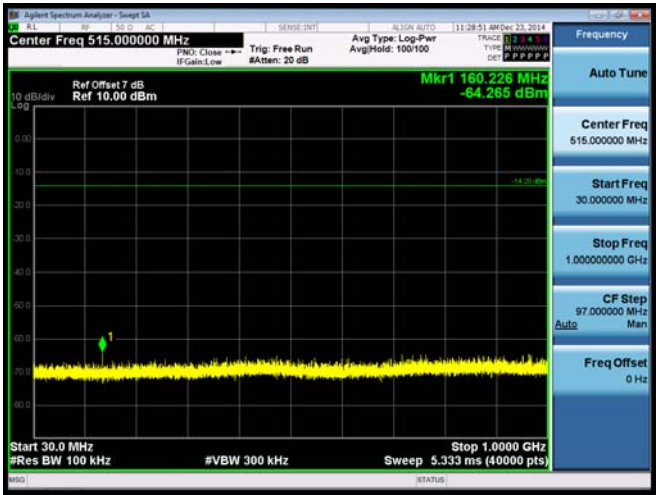
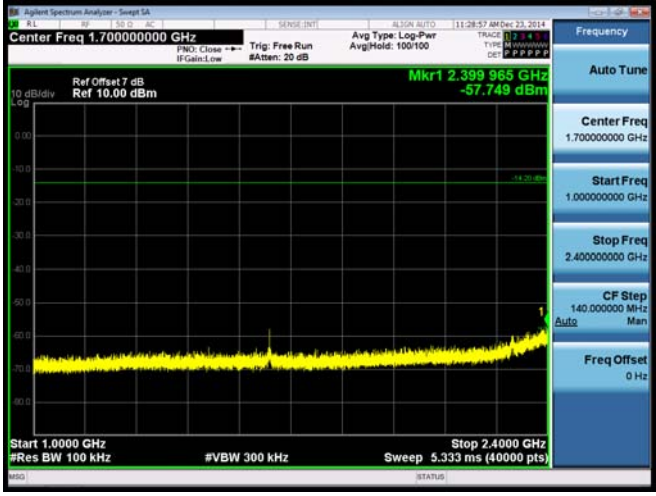
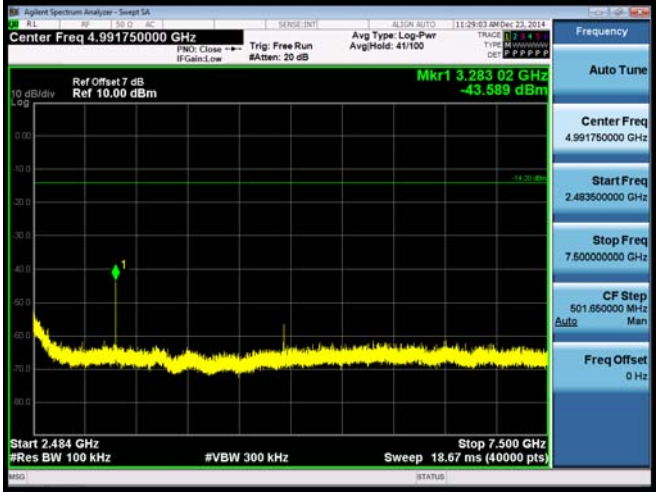

30MHz-1GHz	
1GHz-2.4GHz	
2.4835GHz-7.5GHz	

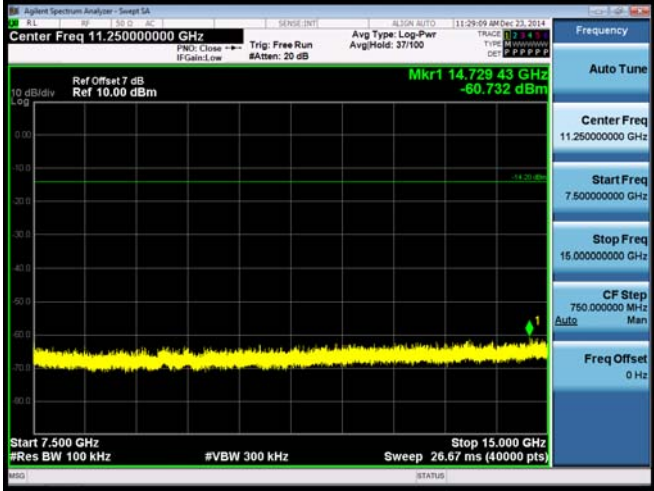
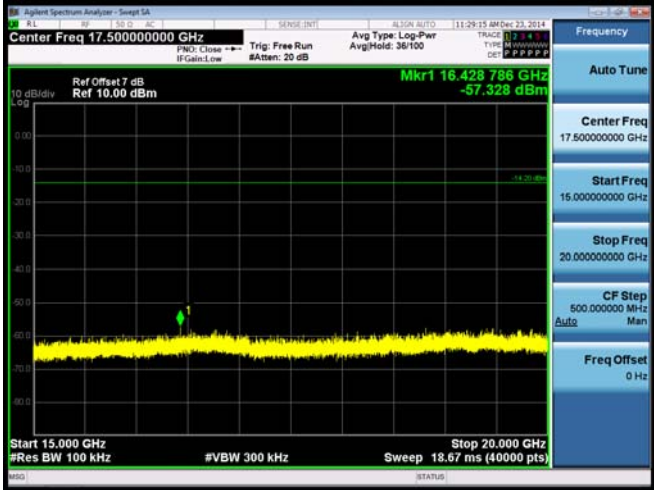

Mode 2: IEEE 802.11b Link Mode-2462

7.5GHz-15GHz	
15GHz-20GHz	
20GHz-25GHz	



Mode 3: IEEE 802.11g Link Mode-2412

9KHz-30MHz

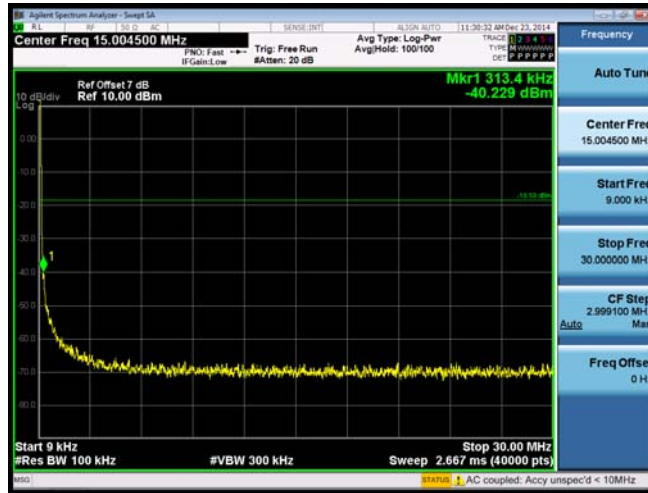

30MHz-1GHz

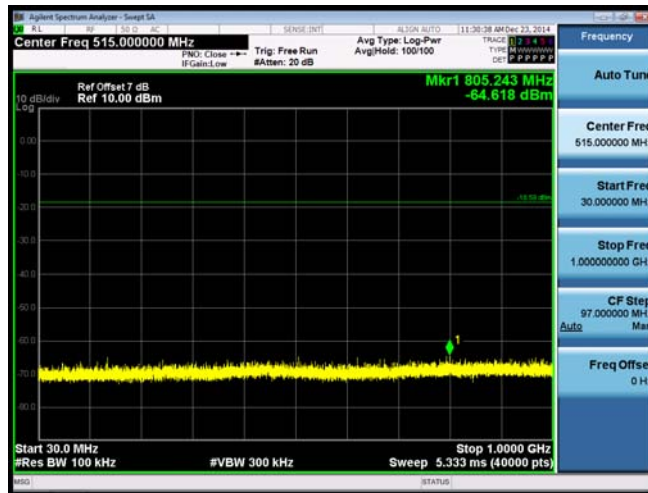

1GHz-2.4GHz

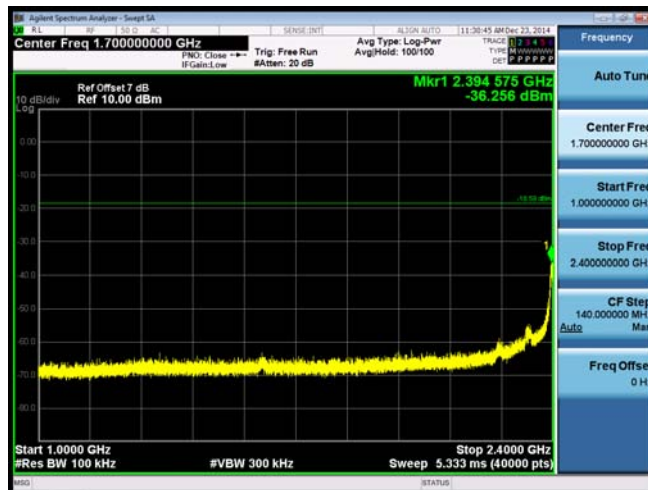

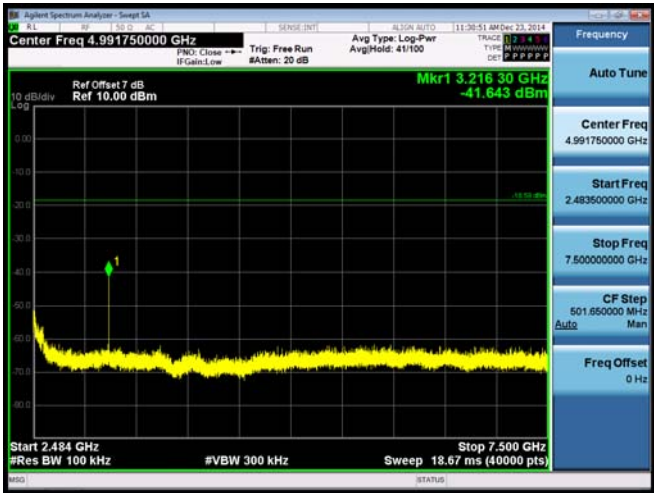
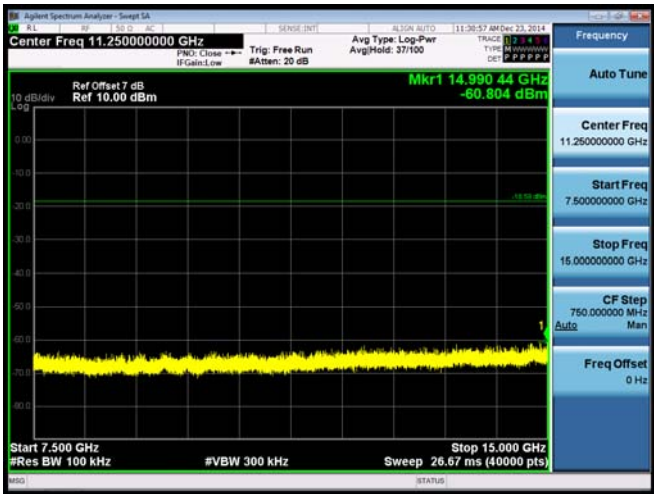
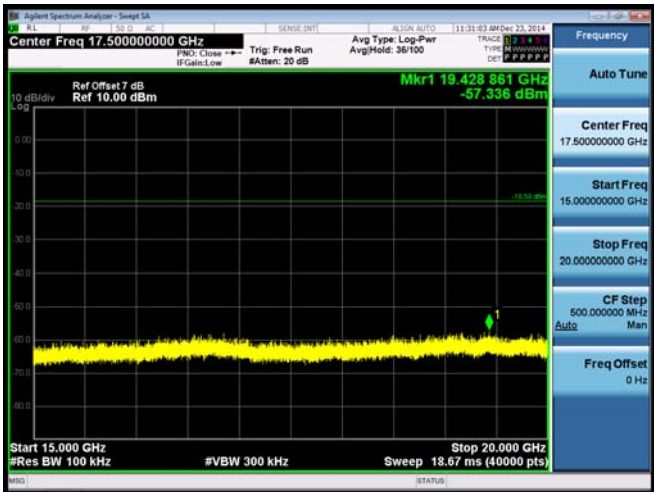

2.4835GHz-7.5GHz	
Mode 3: IEEE 802.11g Link Mode-2412	
7.5GHz-15GHz	
15GHz-20GHz	

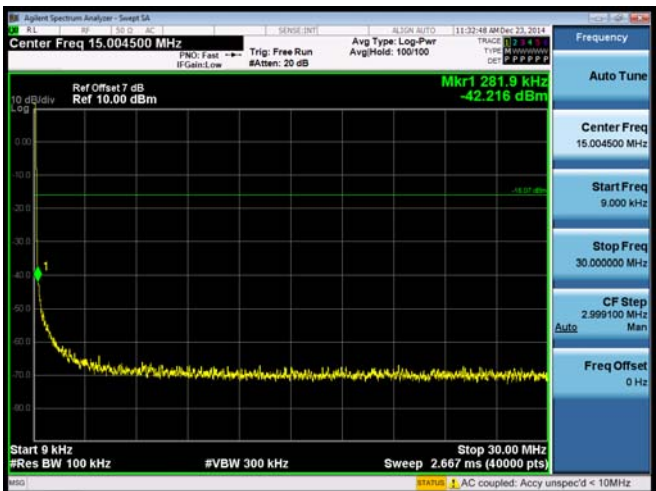
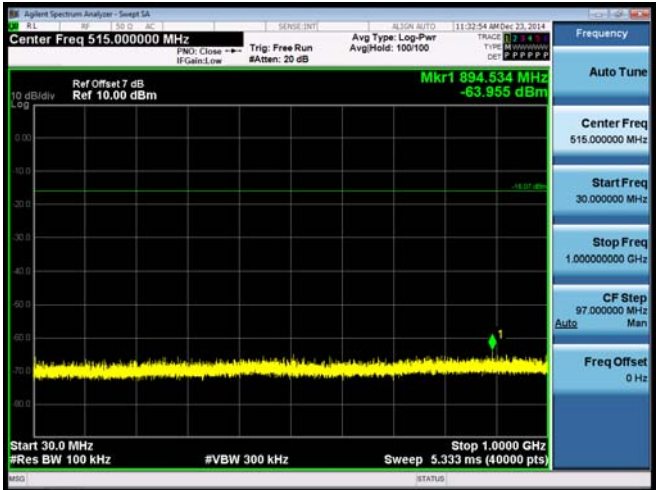

20GHz-25GHz	
Mode 3: IEEE 802.11g Link Mode-2437	
9kHz-30MHz	
30MHz-1GHz	



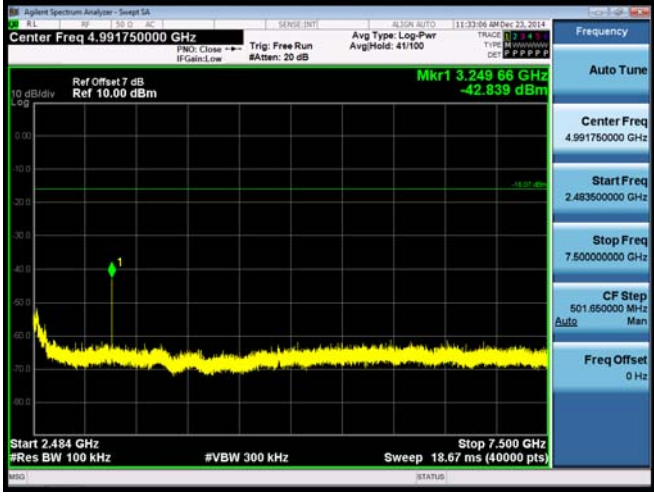
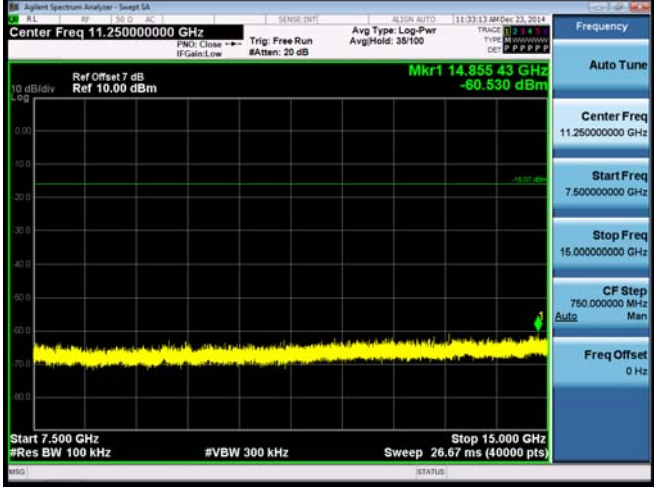

1GHz-2.4GHz	
2.4835GHz-7.5GHz	
Mode 3: IEEE 802.11g Link Mode-2437	
7.5GHz-15GHz	

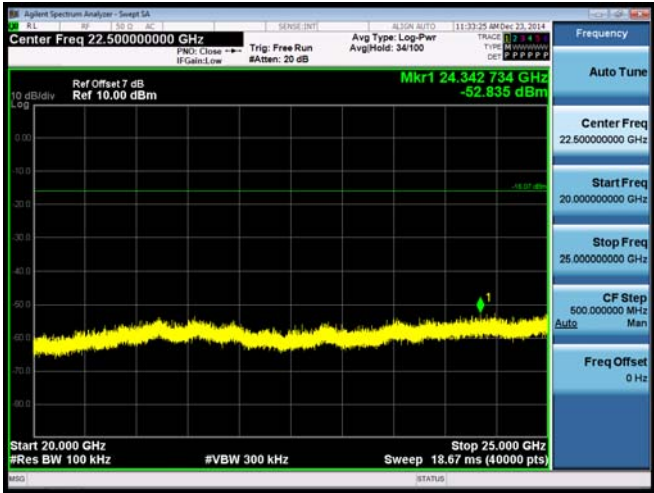
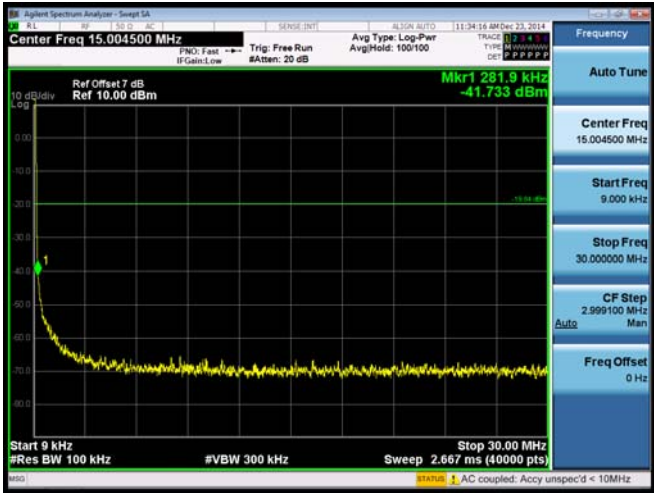

15GHz-20GHz	
20GHz-25GHz	
Mode 3: IEEE 802.11g Link Mode-2462	
9kHz-30MHz	

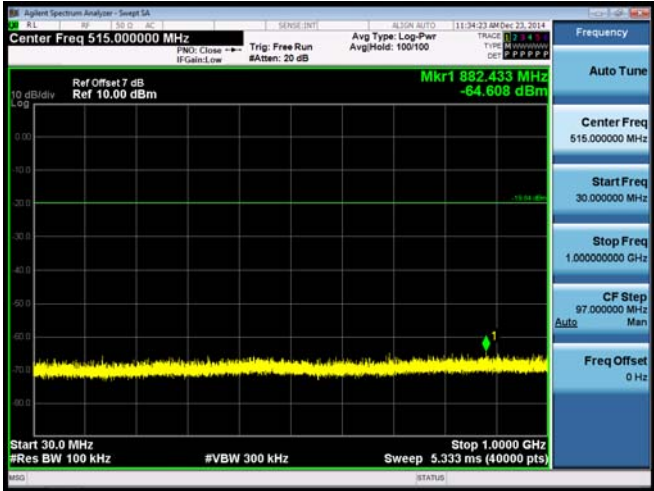
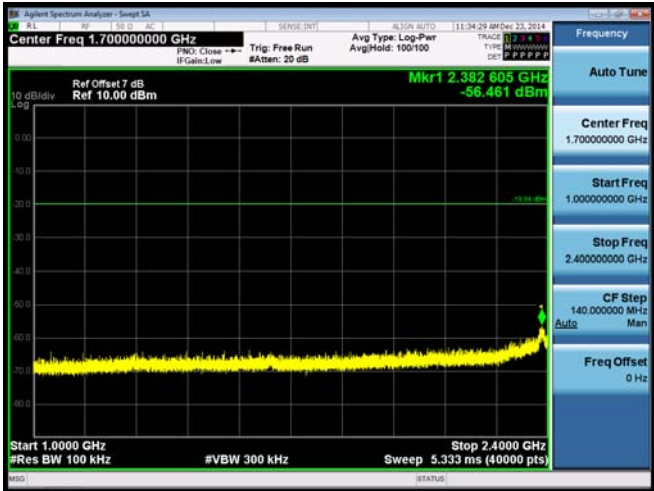

30MHz-1GHz	
1GHz-2.4GHz	
2.4835GHz-7.5GHz	

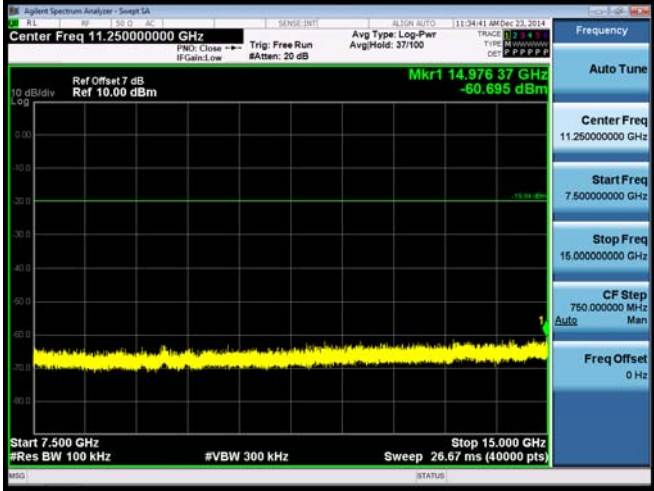
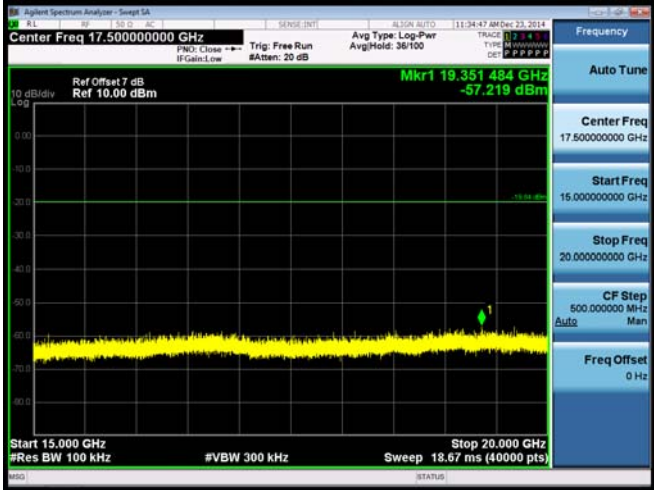
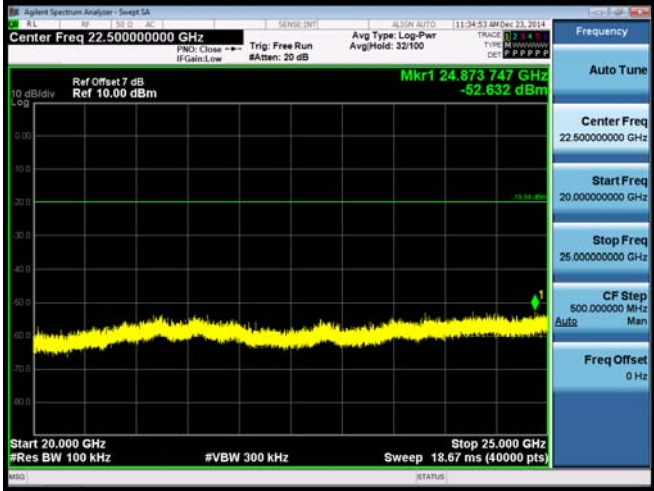

Mode 3: IEEE 802.11g Link Mode-2462

7.5GHz-15GHz	
15GHz-20GHz	
20GHz-25GHz	



Mode 4: IEEE 802.11n 2.4G 20MHz Link Mode-2412

9KHz-30MHz

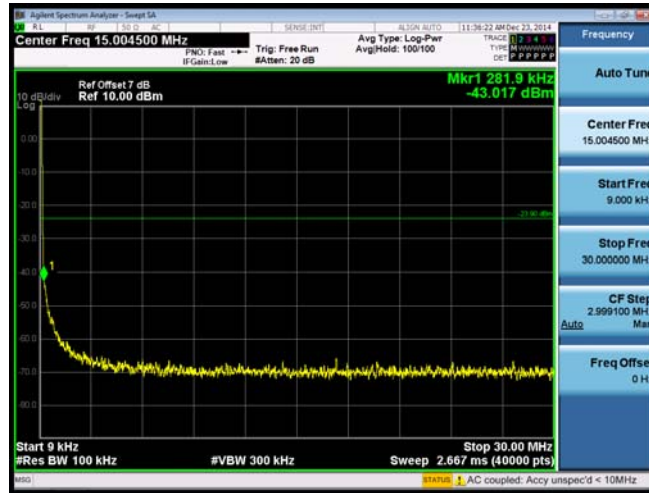

30MHz-1GHz

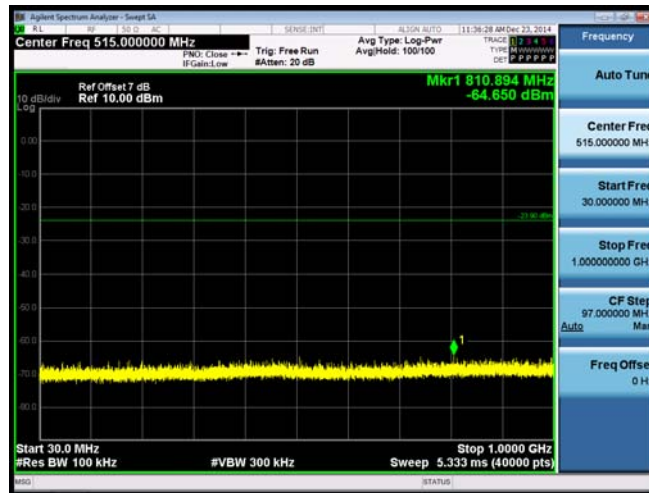

1GHz-2.4GHz

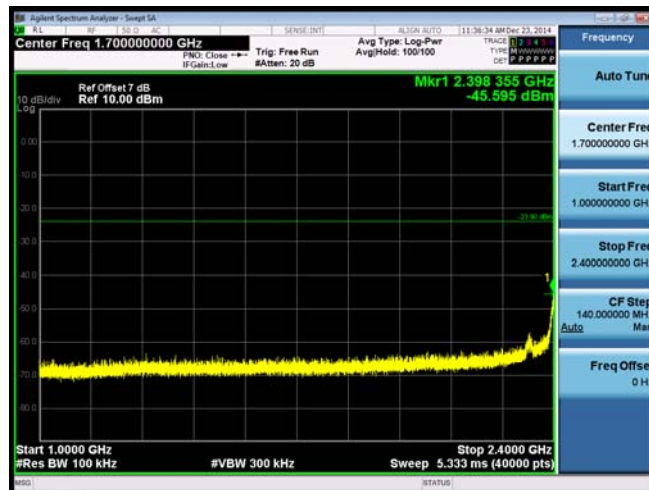

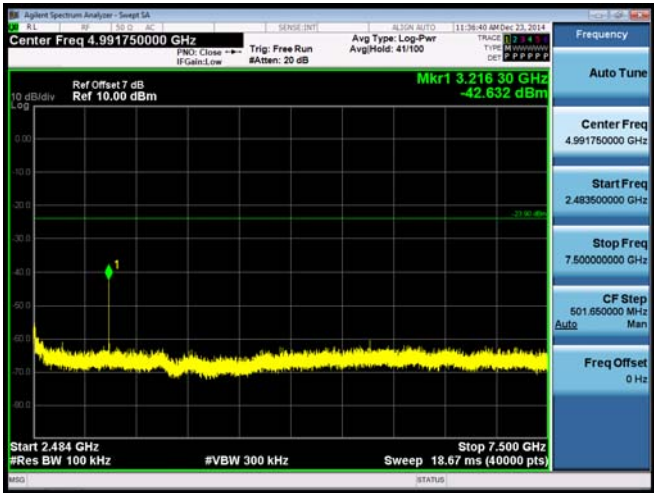
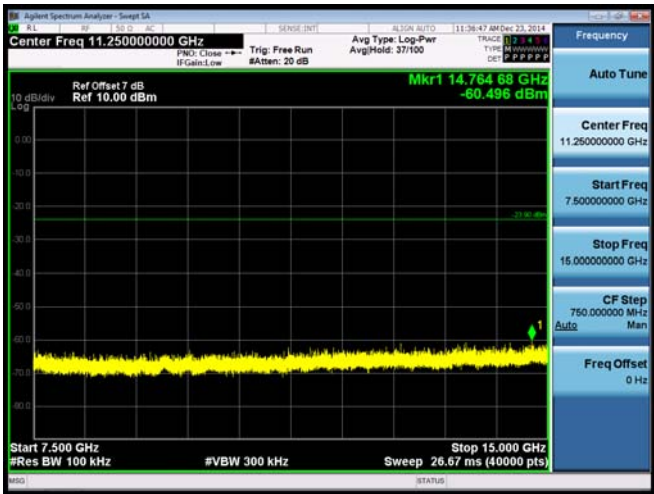
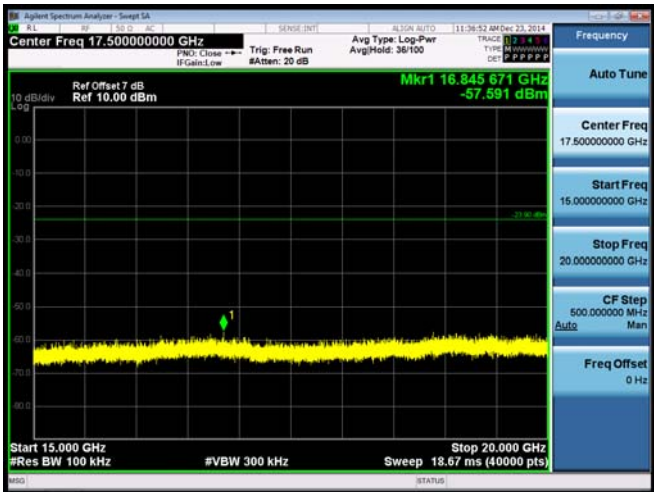

<p>2.4835GHz-7.5GHz</p>	
<p>Mode 4: IEEE 802.11n 2.4G 20MHz Link Mode-2412</p>	
<p>7.5GHz-15GHz</p>	
<p>15GHz-20GHz</p>	



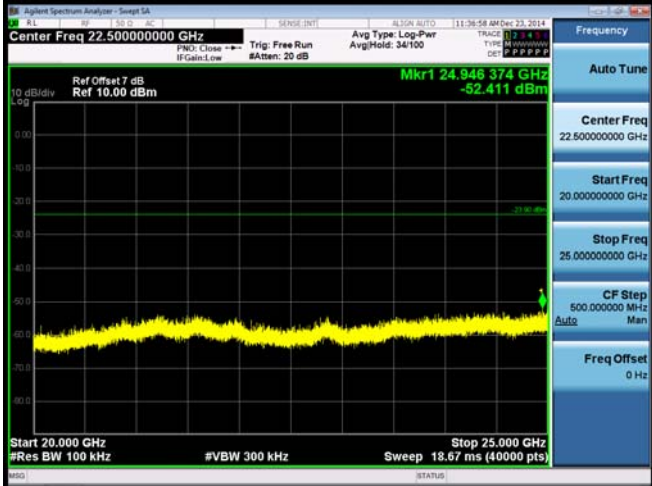
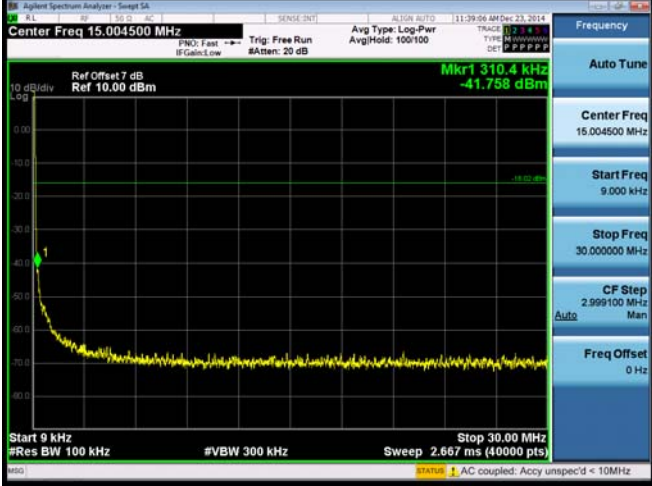
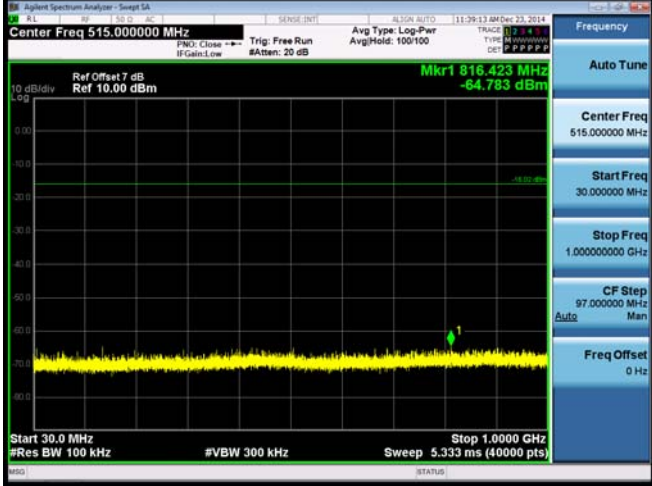

20GHz-25GHz	
Mode 4: IEEE 802.11n 2.4G 20MHz Link Mode-2437	
9kHz-30MHz	
30MHz-1GHz	

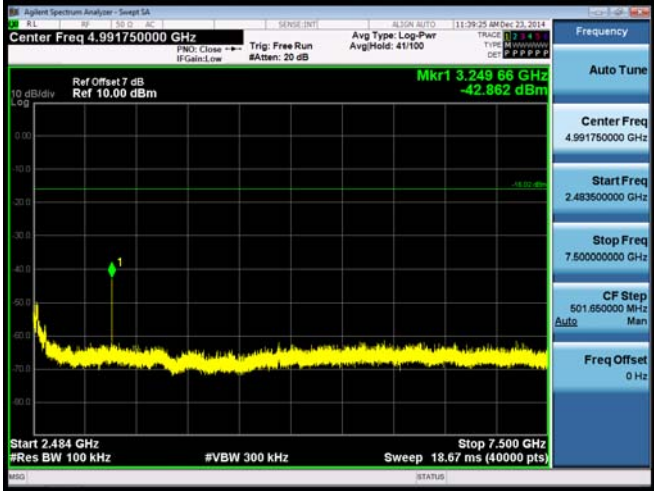
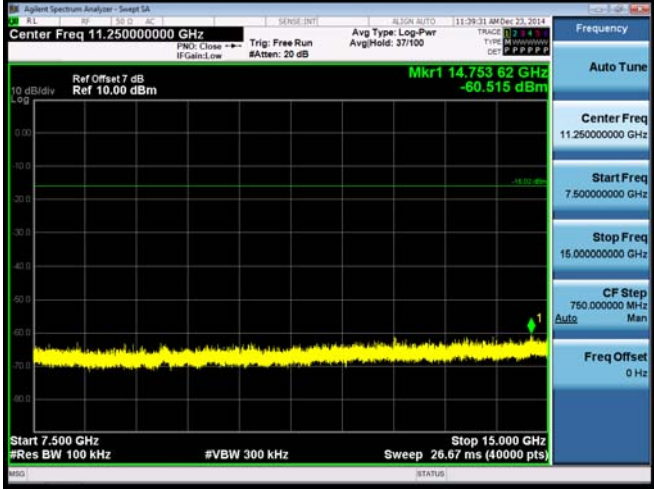

1GHz-2.4GHz	
2.4835GHz-7.5GHz	
Mode 4: IEEE 802.11n 2.4G 20MHz Link Mode-2437	
7.5GHz-15GHz	

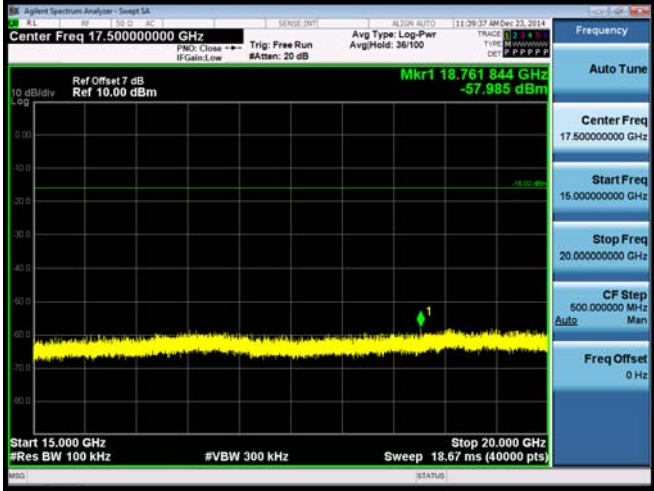

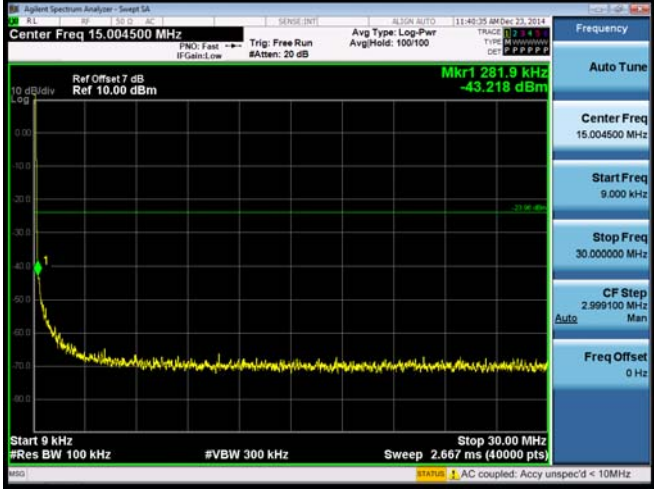
15GHz-20GHz	
20GHz-25GHz	
Mode 4: IEEE 802.11n 2.4G 20MHz Link Mode-2462	
9KHz-30MHz	

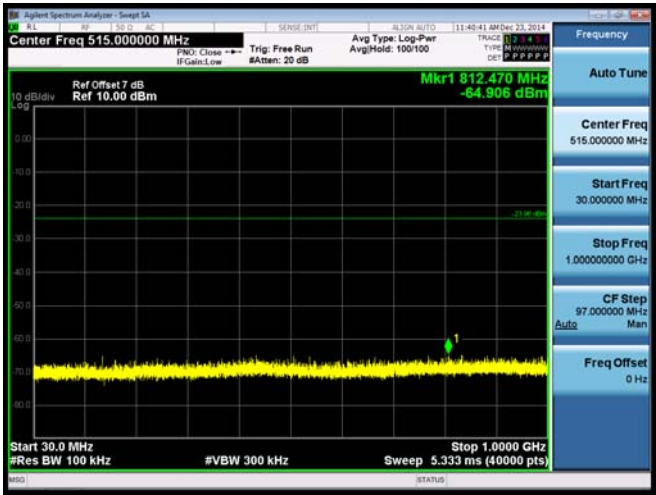
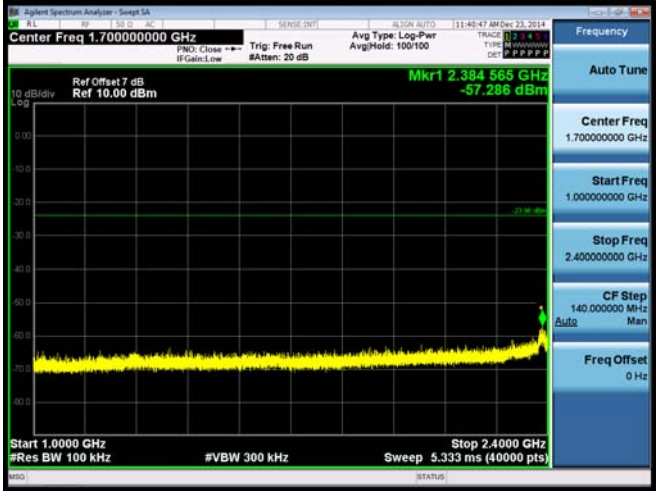
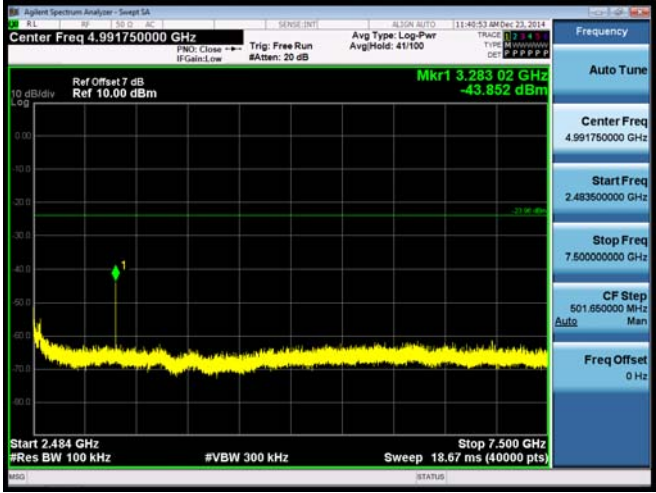

30MHz-1GHz	
1GHz-2.4GHz	
2.4835GHz-7.5GHz	

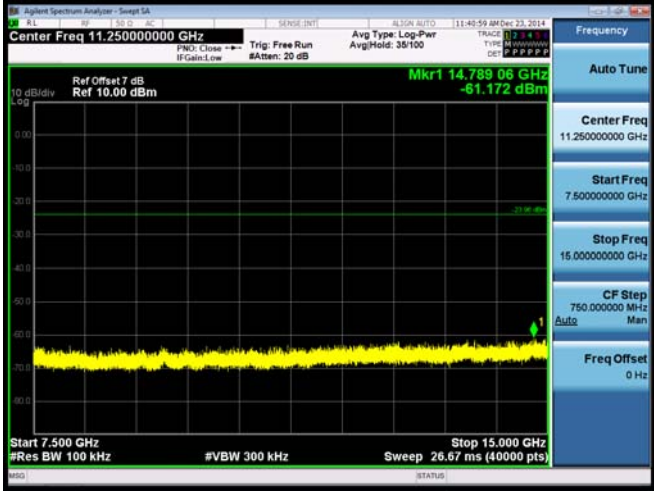
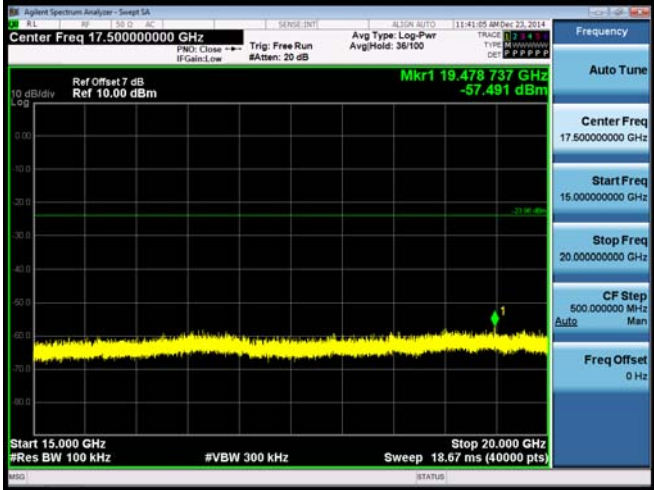
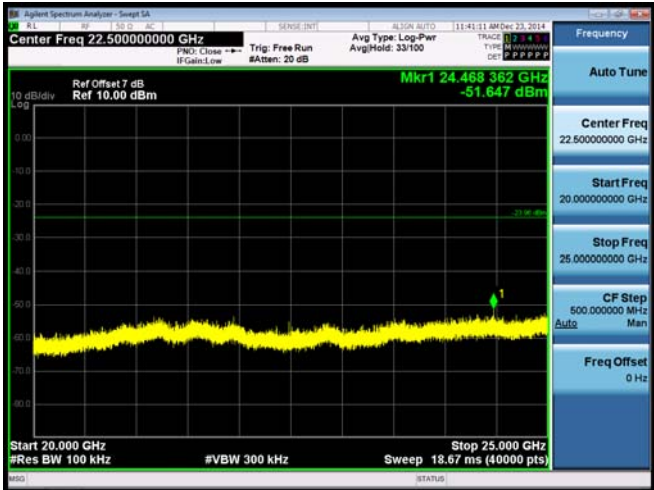

Mode 4: IEEE 802.11n 2.4G 20MHz Link Mode-2462

7.5GHz-15GHz	
15GHz-20GHz	
20GHz-25GHz	



Mode 5: IEEE 802.11n 2.4G 40MHz Link Mode-2422

9KHz-30MHz

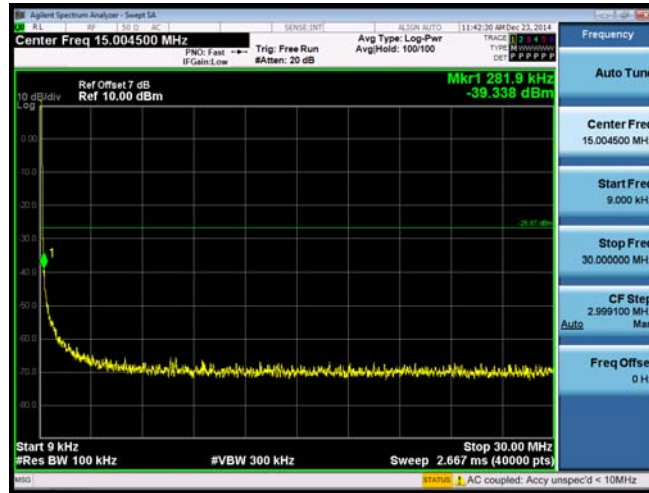

30MHz-1GHz

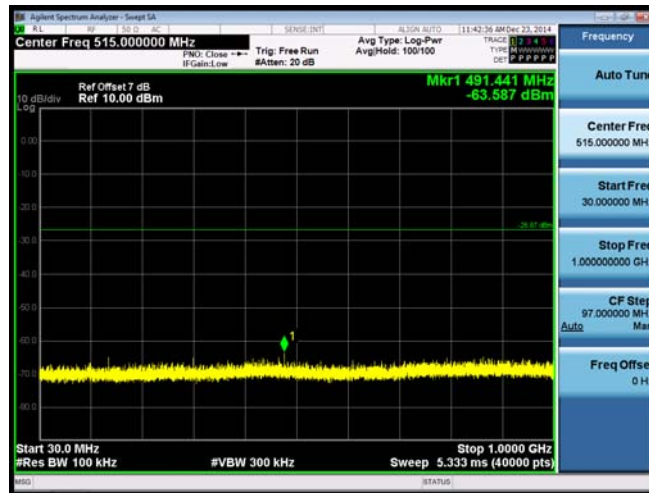

1GHz-2.4GHz

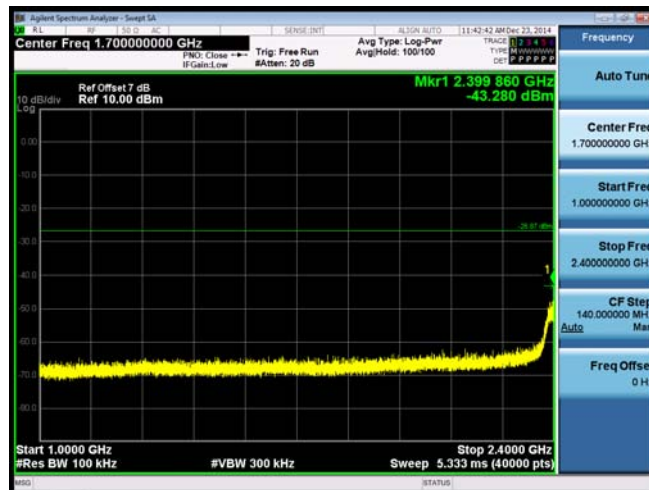



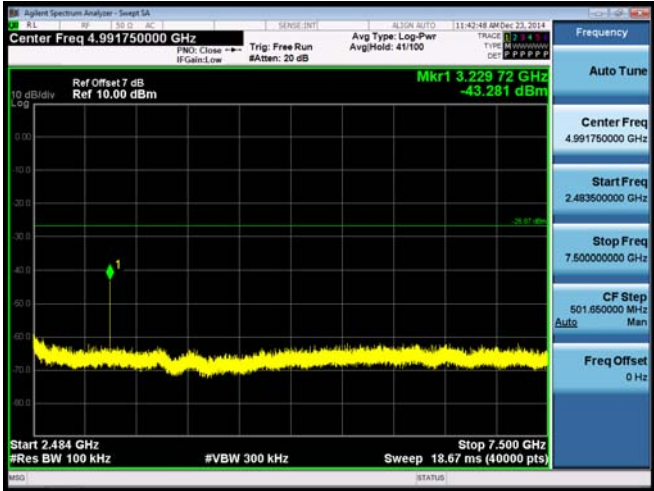
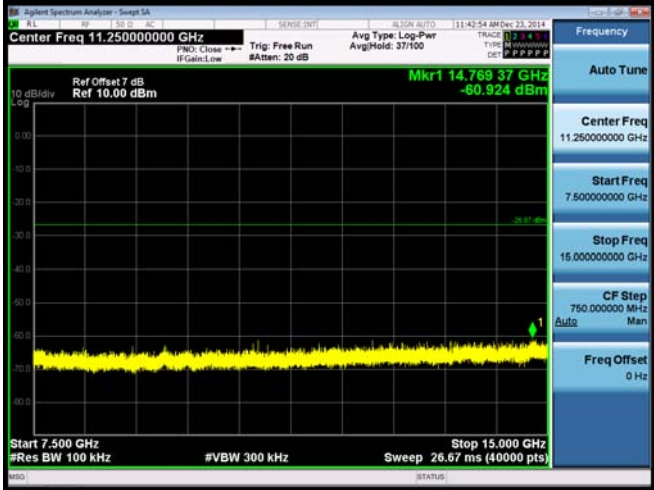
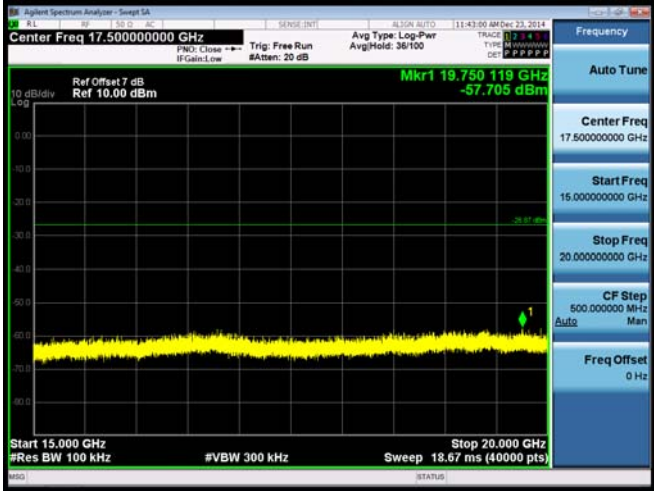

2.4835GHz-7.5GHz	
Mode 5: IEEE 802.11n 2.4G 40MHz Link Mode-2412	
7.5GHz-15GHz	
15GHz-20GHz	

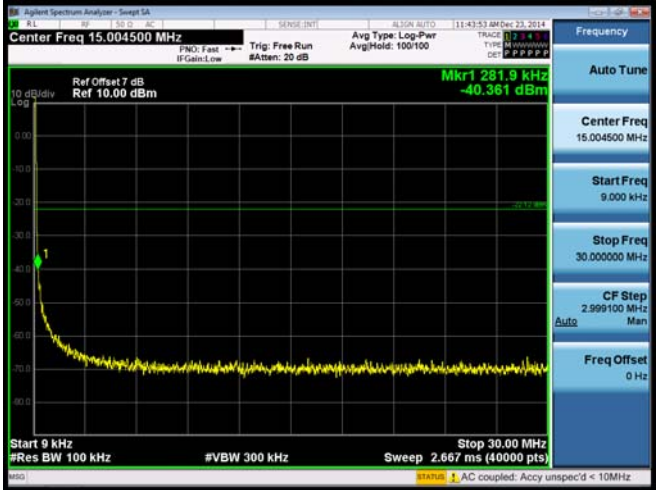
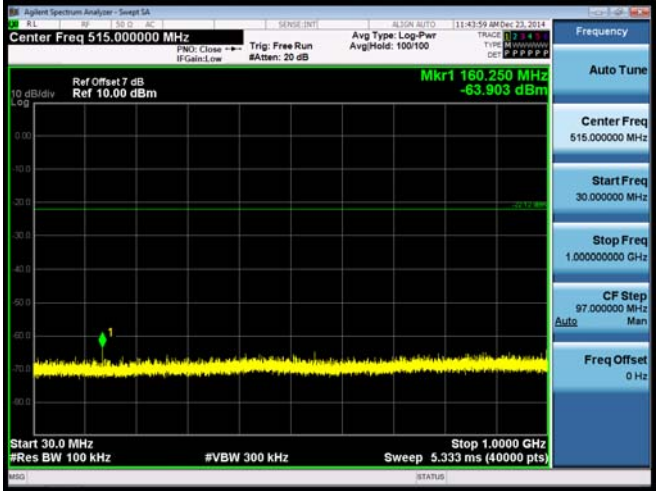



<p>20GHz-25GHz</p>	
<p>Mode 5: IEEE 802.11n 2.4G 40MHz Link Mode-2437</p>	
<p>9KHz-30MHz</p>	
<p>30MHz-1GHz</p>	

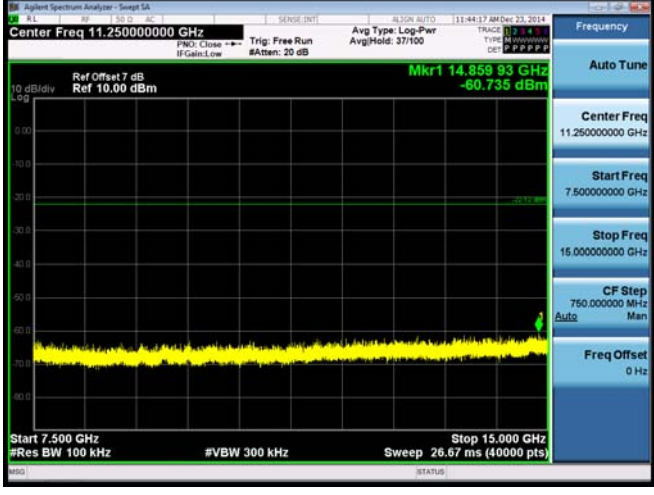

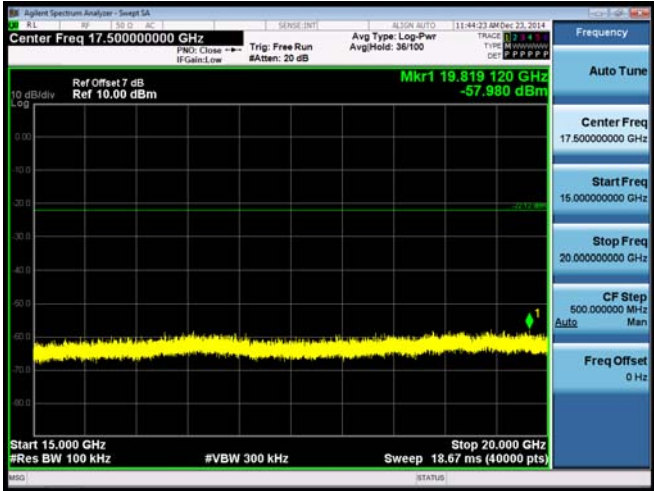

1GHz-2.4GHz	
2.4835GHz-7.5GHz	
Mode 5: IEEE 802.11n 2.4G 40MHz Link Mode-2437	
7.5GHz-15GHz	

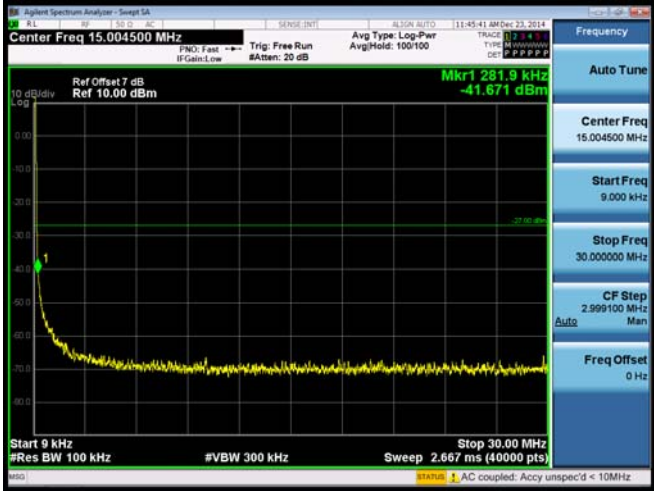

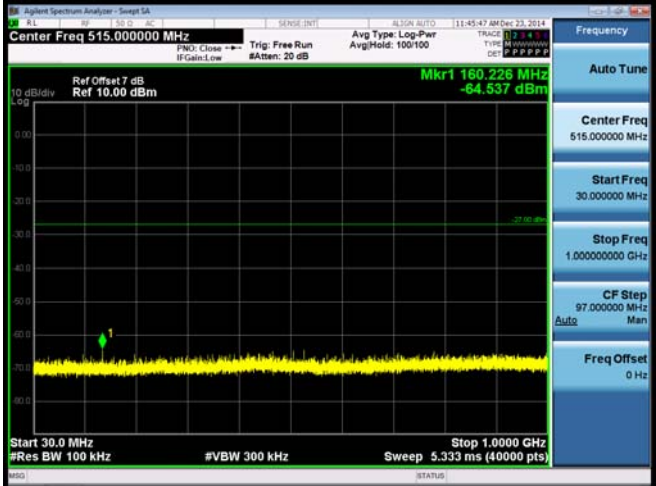

15GHz-20GHz	
20GHz-25GHz	
Mode 5: IEEE 802.11n 2.4G 40MHz Link Mode-2452	
9KHz-30MHz	

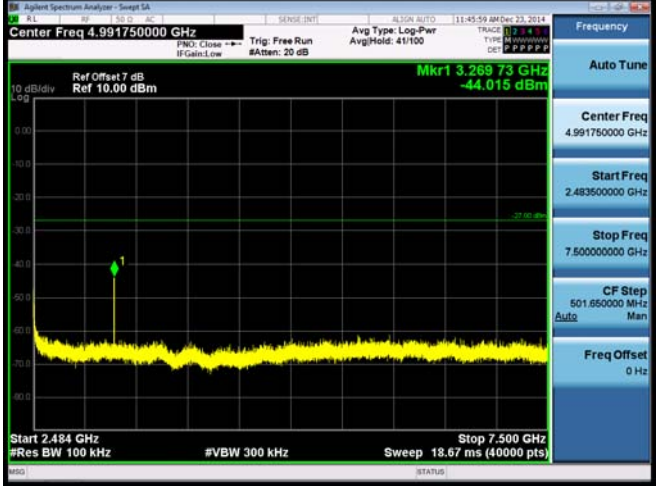

30MHz-1GHz	
1GHz-2.4GHz	
2.4835GHz-7.5GHz	

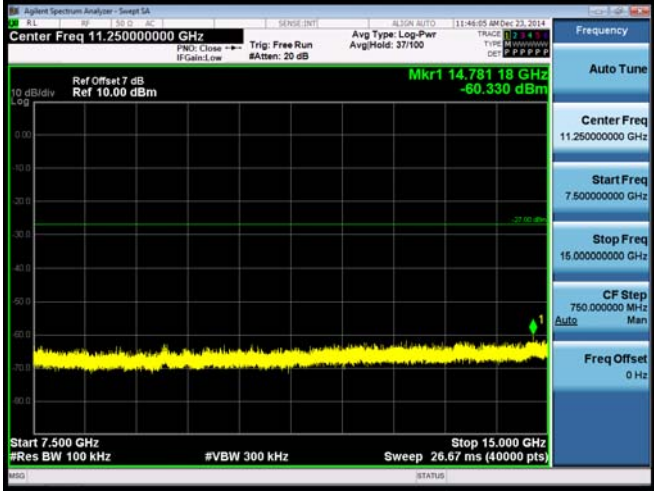
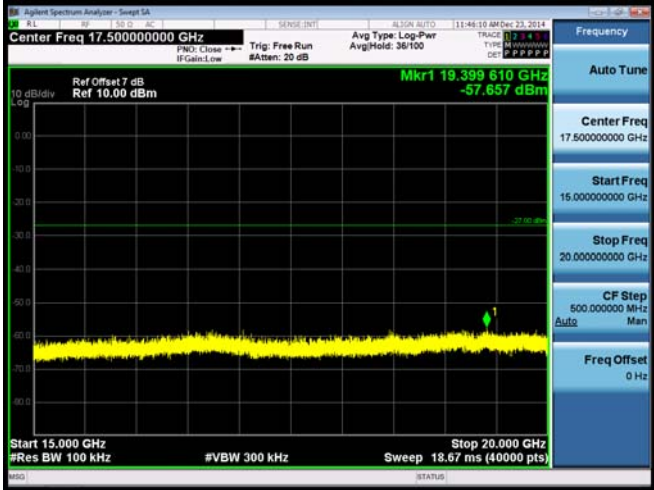

Mode 5: IEEE 802.11n 2.4G 40MHz Link Mode-2462

7.5GHz-15GHz	
15GHz-20GHz	
20GHz-25GHz	

10 Band Edges Measurement

10.1.Limit

In any 100 kHz bandwidth outside the intentional radiation frequency band, the radio frequency power shall be at least 20 dB below the highest level of the radiated power. In addition, radiated emissions which fall in the restricted bands must also comply with the radiated emission limits.

10.2.Test Setup

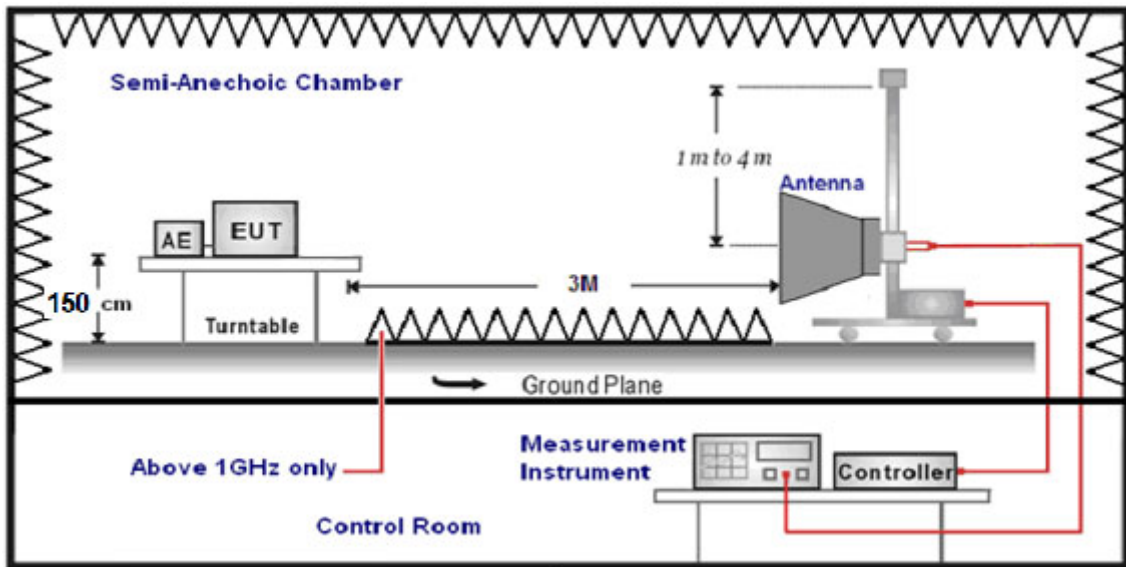

10.3.Test Instruments

Radiated Bandedge Emission				
Description	Type No.	Serial No.	Calibrated date	Calibrated until
EMI Test Receiver	ESU40	SB8501/09	2014.05.16	2015.05.15
Horn Antenna	HF906	SB3435	2014.01.20	2017.01.19
Amplifier(1-18GHz)	--	SB3435/01	2014.01.20	2015.01.19
3m Semi-anechoic chamber	9X6X6	SB3450/01	2014.10.12	2015.10.11
RF cable(3.5m)	/	S02-1404-09-047	2014.05.11	2015.05.10
RF cable(1.2m)	/	S02-1404-09-052	2014.05.11	2015.05.10
Test Software	EMC32	N/A	N/A	N/A



10.4. TEST CONFIGURATION

1. The EUT was placed on a turn table which is 1.5m above ground plane with absorber refer to ANSI C63.10:2013
2. Maximum procedure was performed by raising the receiving antenna from 1m to 4m and rotating the turn table from 0° to 360° to acquire the highest emissions from EUT
3. And also, each emission was to be maximized by changing the polarization of receiving antenna both horizontal and vertical.
4. Repeat above procedures until all frequency measurements have been completed.
5. Test antenna was located 3 distances from the EUT on an adjustable mast.
6. Set the spectrum analyzer/receiver in the following setting as:
Above 1 GHz (Spectrum analyzer)
 - a) Peak values: RBW=1MHz/VBW=3MHz/Sweep=Auto/Dector: Peak
 - b) Average values: RBW=1MHz/VBW=10Hz/Sweep=1s/Dector: Peak



10.5. Test Result

Conducted Band Edge

Mode 2: IEEE 802.11b Link Mode

2412



2462

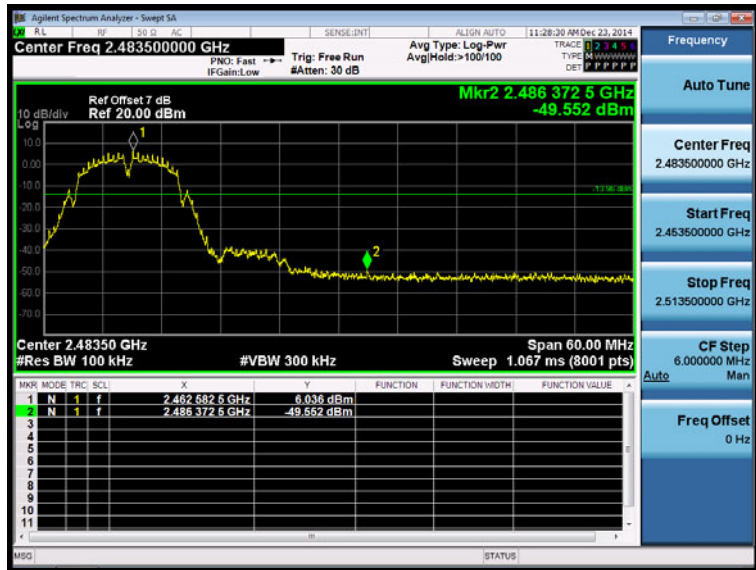



Mode 3: IEEE 802.11g Link Mode

2412

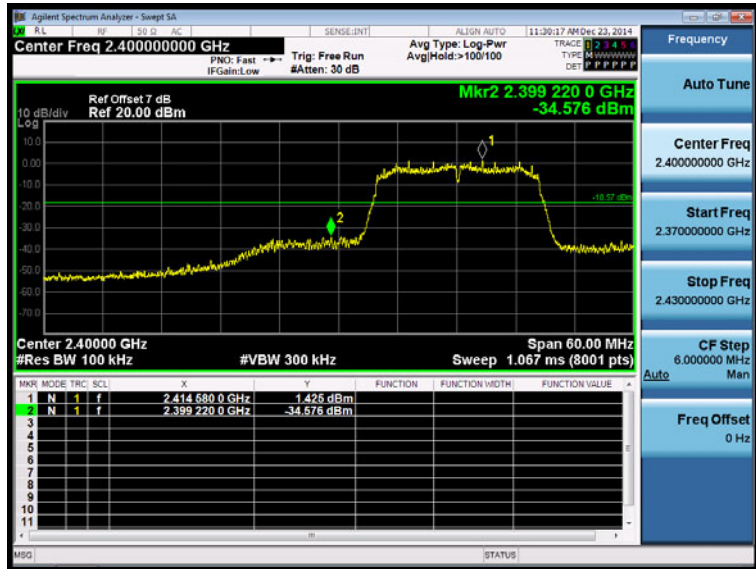

2462

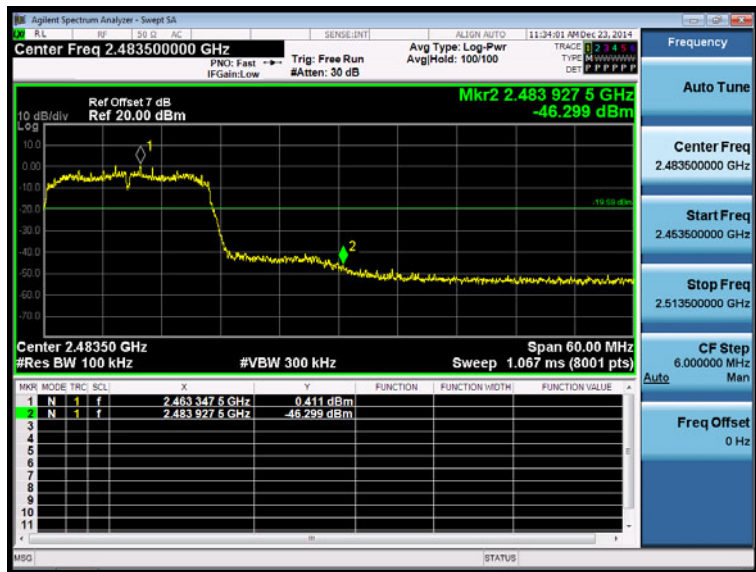



Mode 4: IEEE 802.11n 2.4GHz 20MHz Link Mode

2412

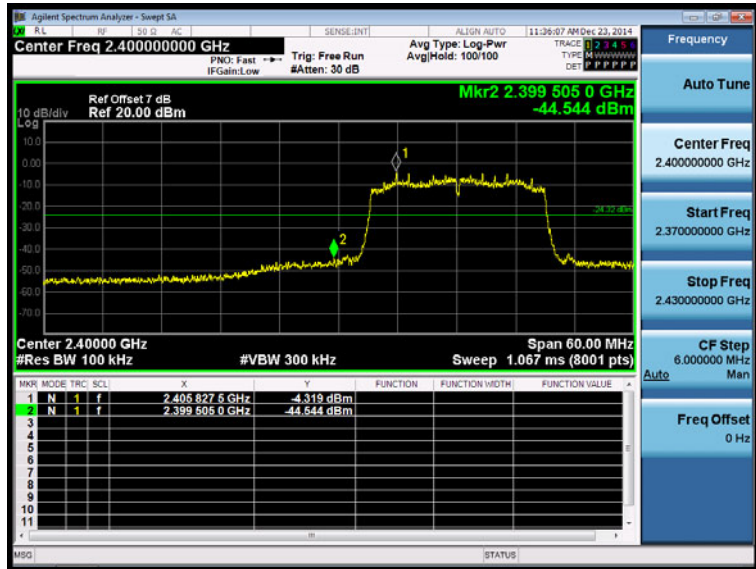

2462

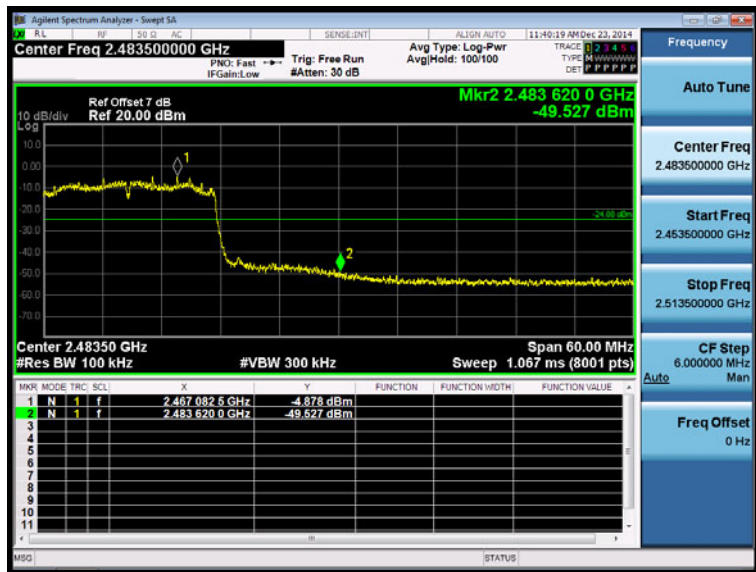



Mode 5: IEEE 802.11n 2.4GHz 40MHz Link Mode

2422

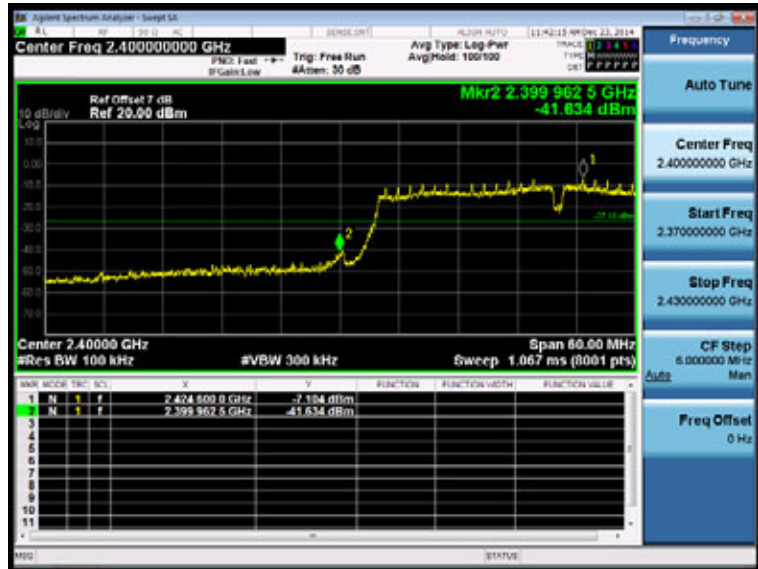

2452

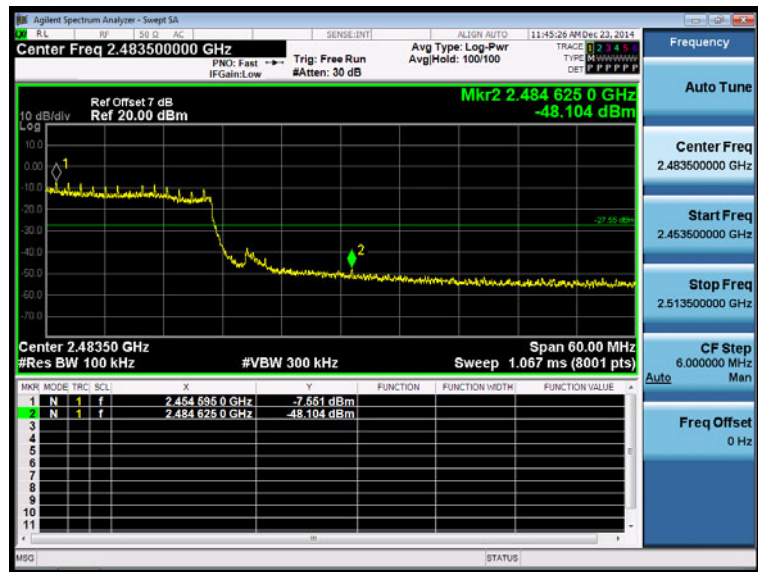



Radiated Band Edge spurious emission

Mode 2: IEEE 802.11b Link Mode

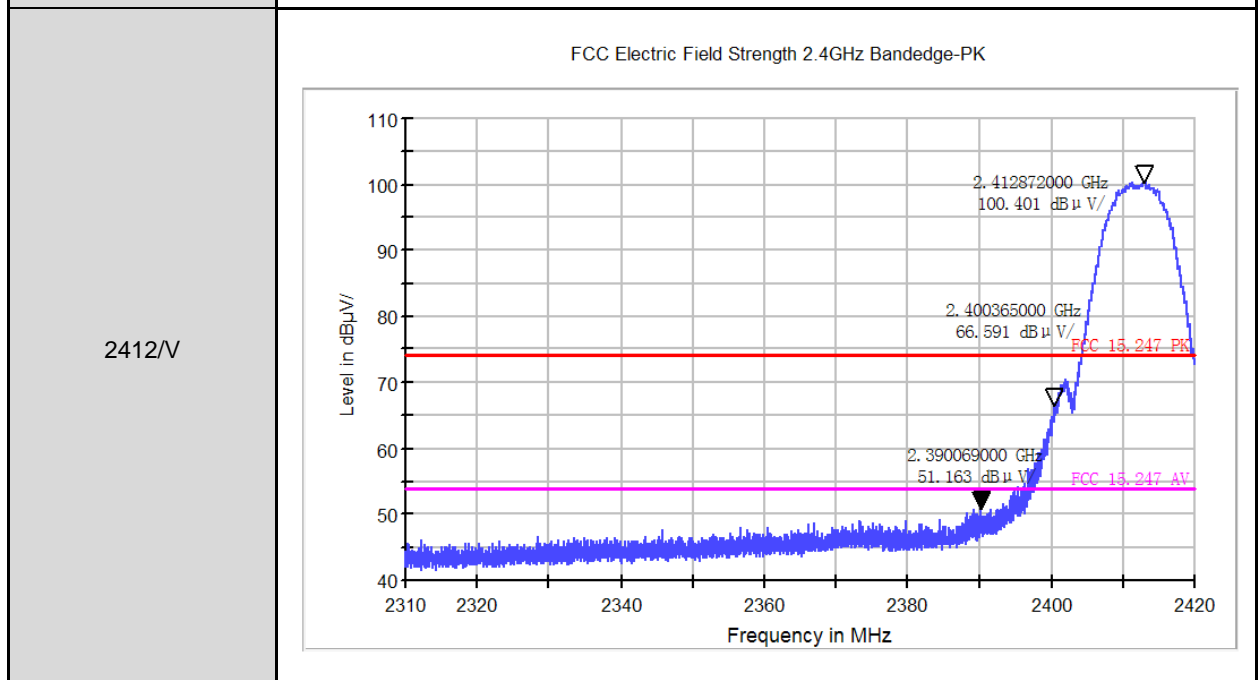
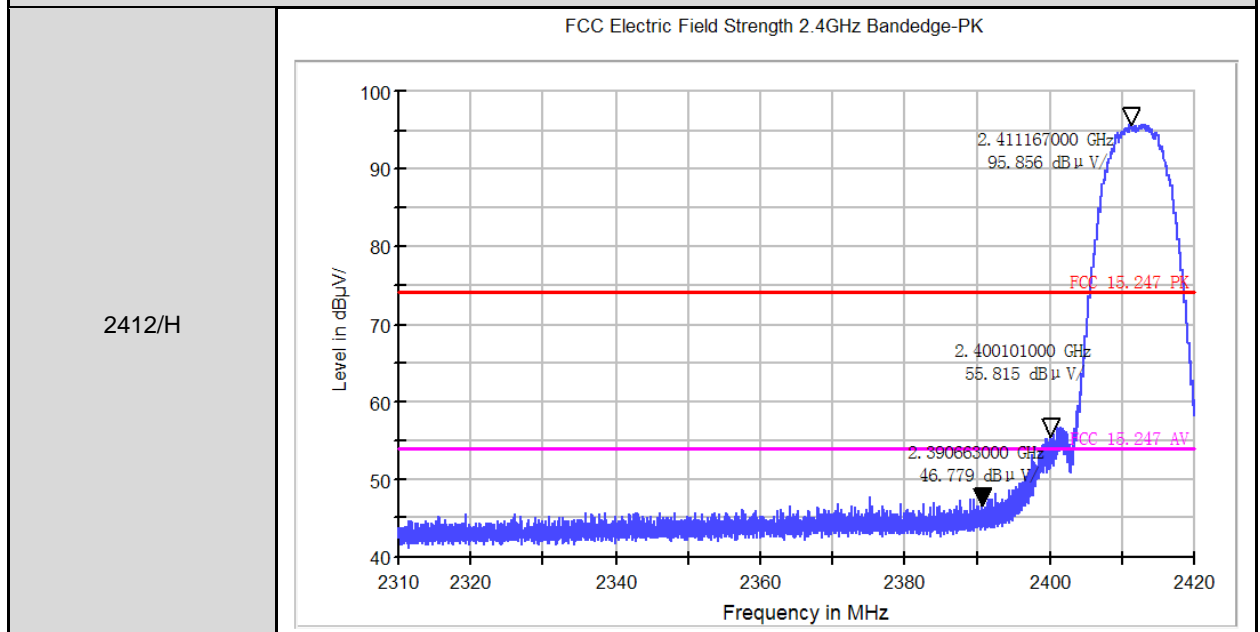

Frequency (MHz)	Result (dBuV/m)	Limit (dBuV/m)	Margin (dB)	Antenna	Remark
2390.7	46.78	74	27.22	H	Peak
2390.7	36.61	54	17.39	H	Average
2390.1	51.16	74	22.84	V	Peak
2390.1	43.24	54	10.76	V	Average



Mode 2: IEEE 802.11b Link Mode

2462/H

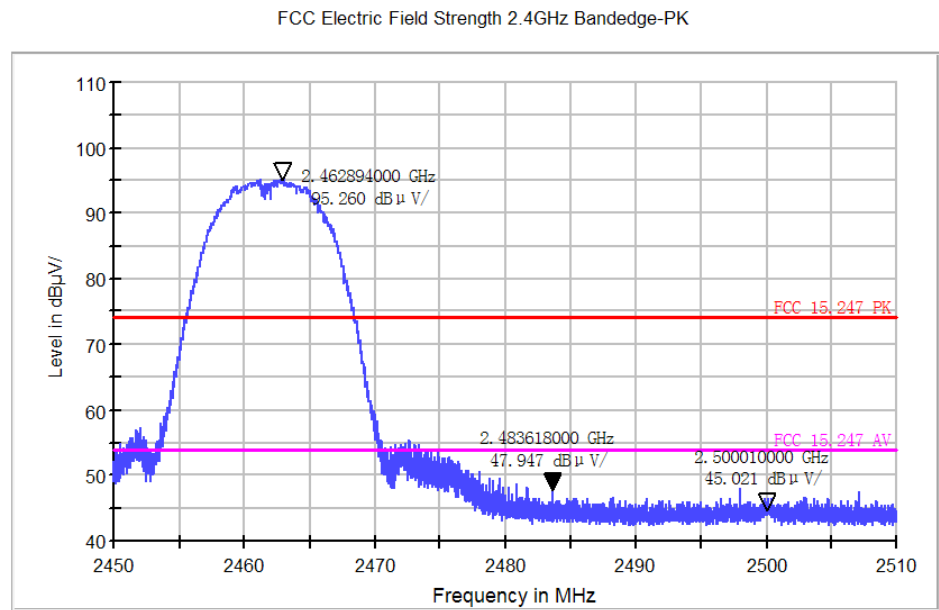

2462/V

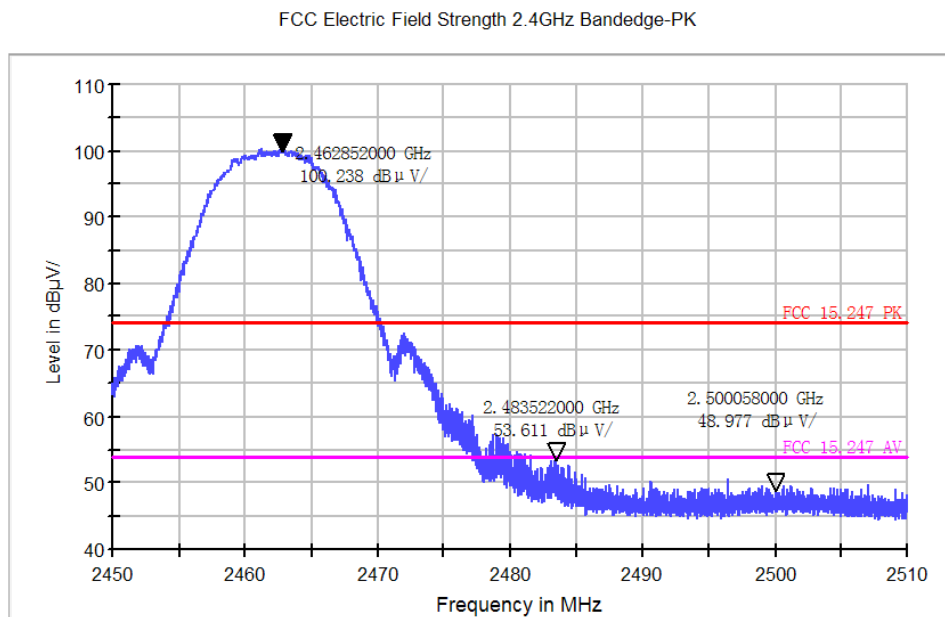

Frequency (MHz)	Result (dBuV/m)	Limit (dBuV/m)	Margin (dB)	Antenna	Remark
2483.6	47.95	74	26.05	H	Peak
2483.6	40.26	54	13.74	H	Average
2483.5	53.61	74	20.39	V	Peak
2483.5	46.62	54	7.38	V	Average



Mode 3: IEEE 802.11g Link Mode

2412/H

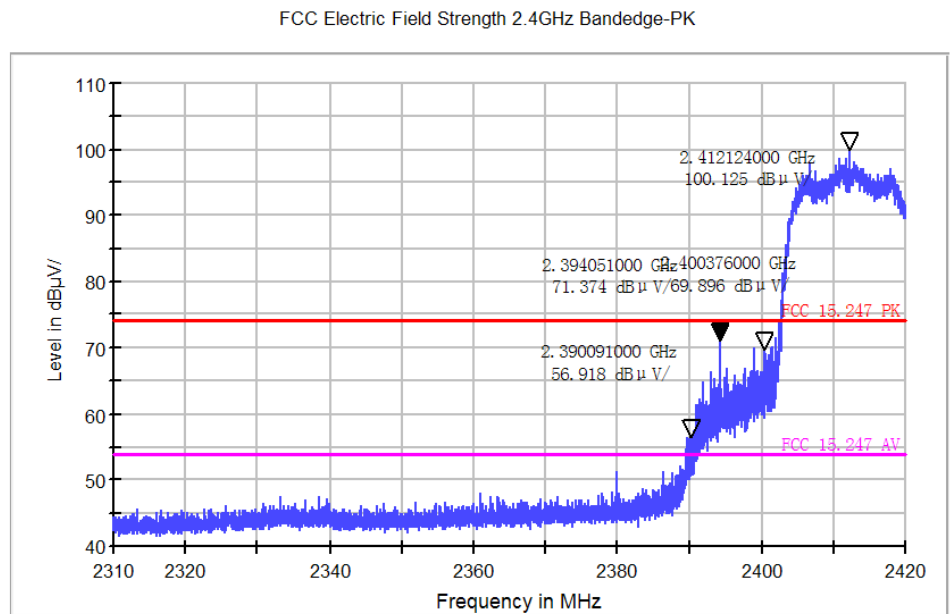

2412/V

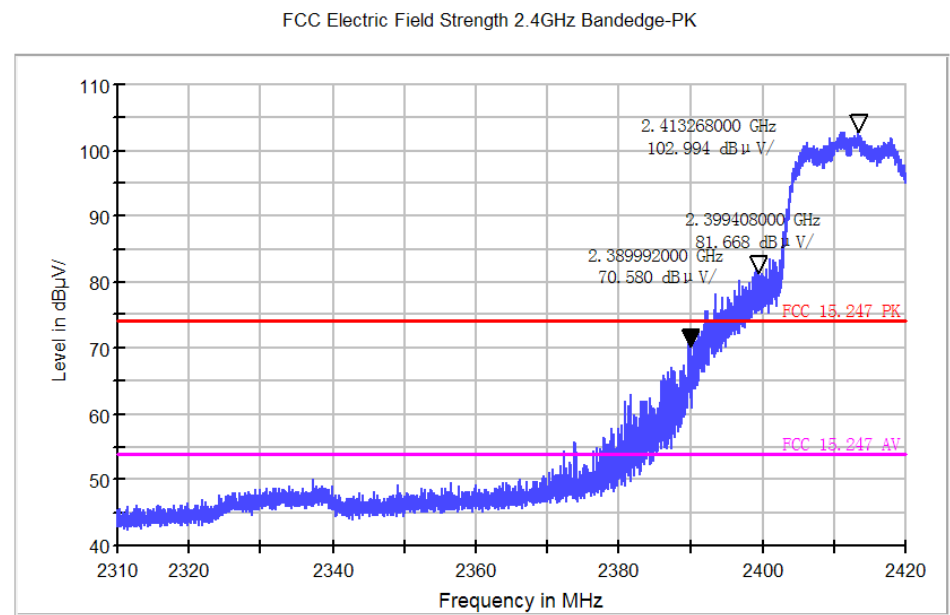

Frequency (MHz)	Result (dBuV/m)	Limit (dBuV/m)	Margin (dB)	Antenna	Remark
2390.1	71.37	74	2.63	H	Peak
2390.1	51.32	54	2.68	H	Average
2389.9	70.58	74	3.42	V	Peak
2390.7	49.26	54	4.74	V	Average



Mode 3: IEEE 802.11g Link Mode

2462/H

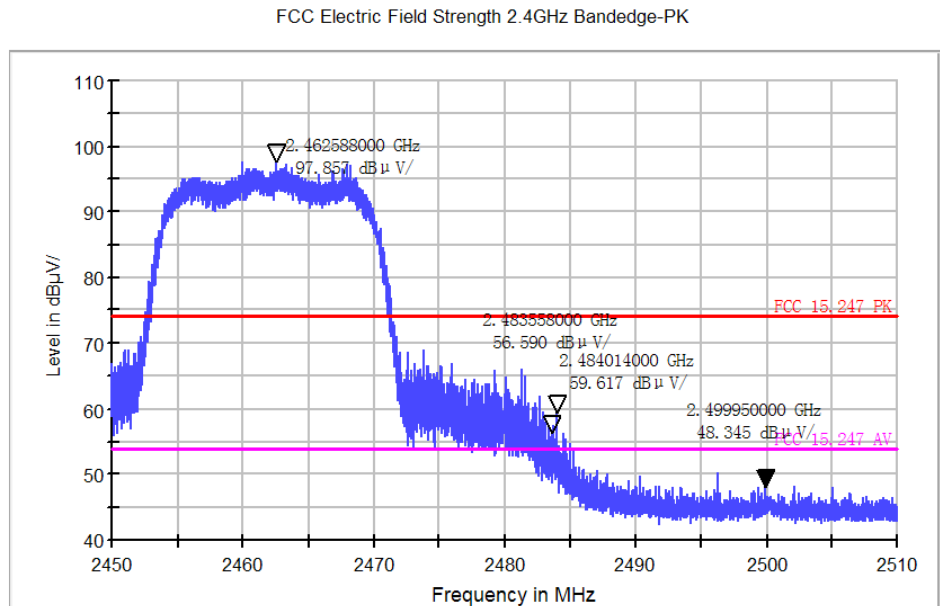

2462/V

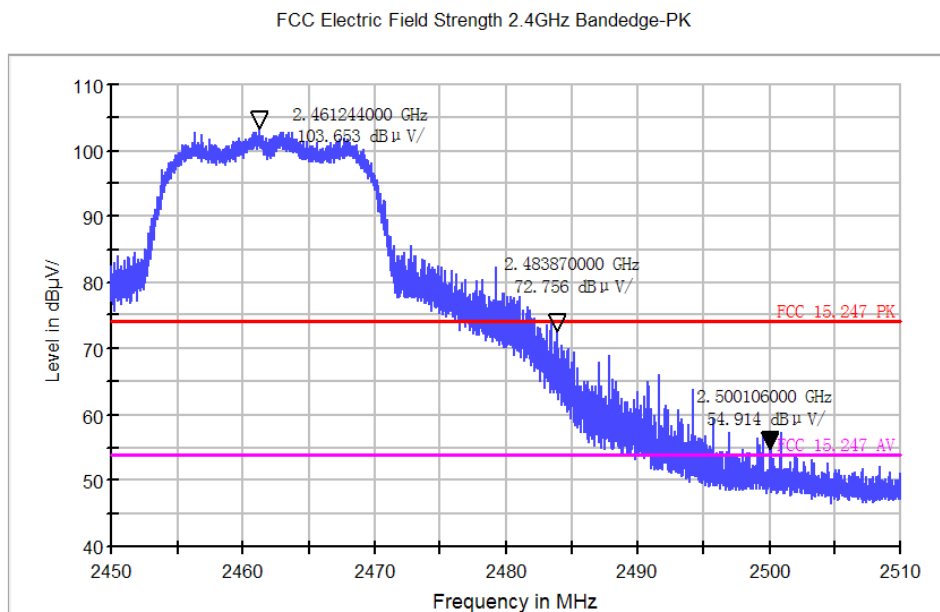

Frequency (MHz)	Result (dBuV/m)	Limit (dBuV/m)	Margin (dB)	Antenna	Remark
2484.0	59.62	74	14.38	H	Peak
2484.0	46.17	54	7.83	H	Average
2483.9	72.58	74	1.42	V	Peak
2483.5	51.03	54	2.97	V	Average



Mode 4: IEEE 802.11n 20MHz Link Mode

2412/H

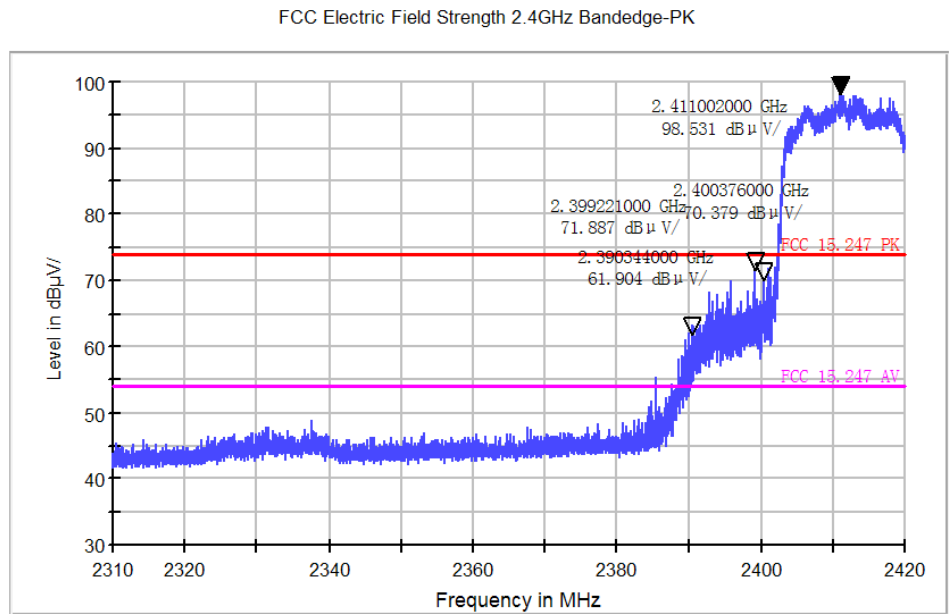

2412/V

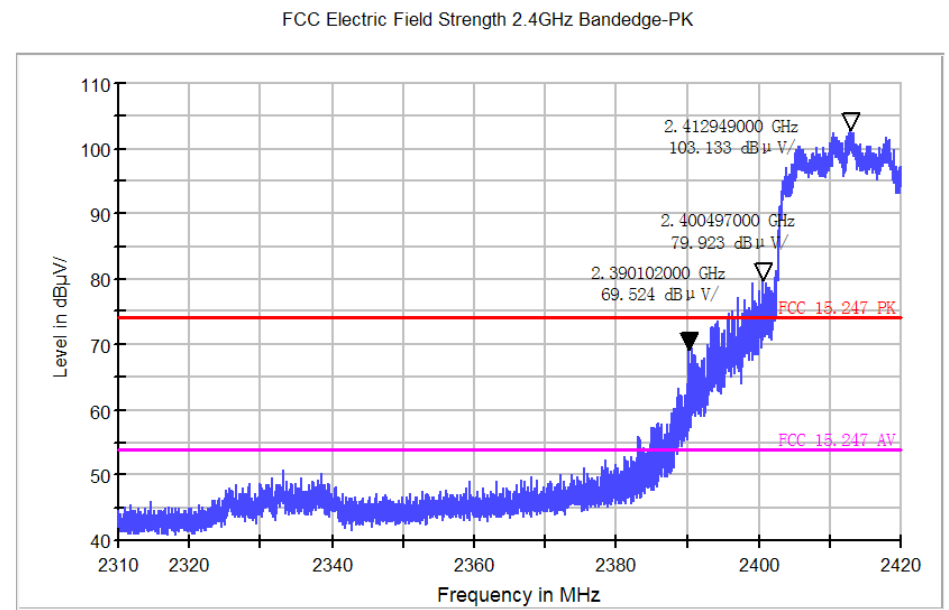

Frequency (MHz)	Result (dBuV/m)	Limit (dBuV/m)	Margin (dB)	Antenna	Remark
2390.3	61.90	74	12.1	H	Peak
2390.9	43.19	54	10.81	H	Average
2390.1	69.52	74	4.48	V	Peak
2390.1	48.16	54	5.84	V	Average



Mode 4: IEEE 802.11n 20MHz Link Mode

2462/H

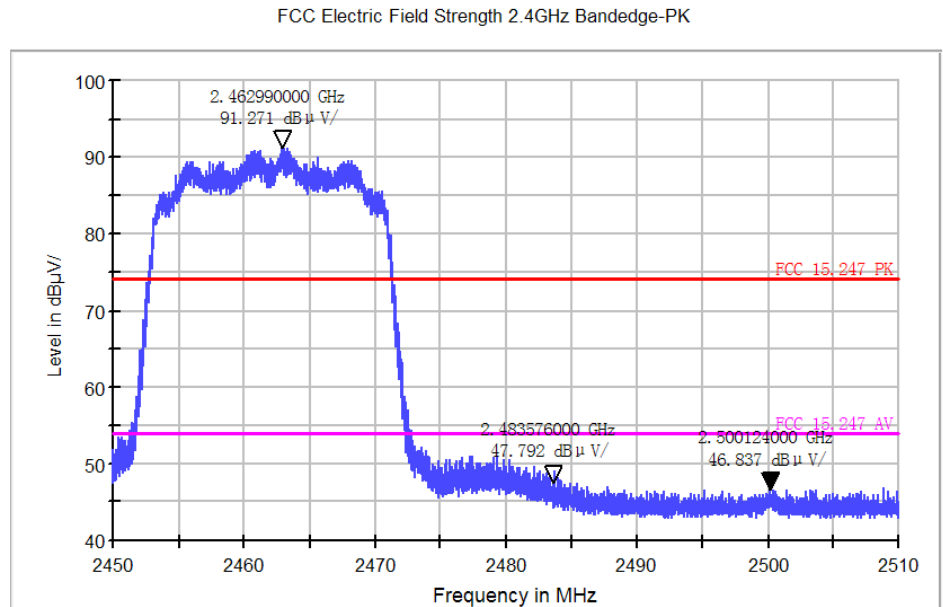

2462/V

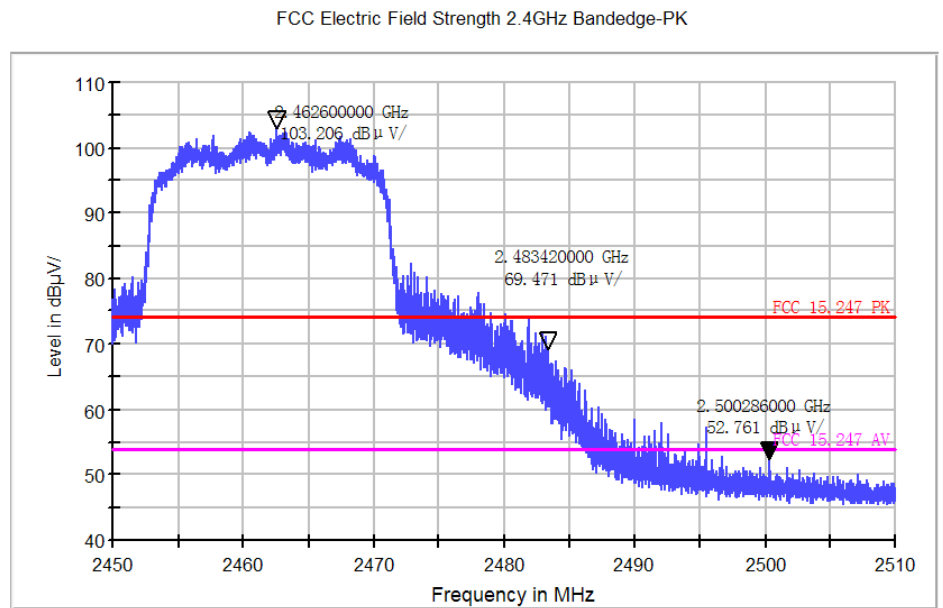

Frequency (MHz)	Result (dBuV/m)	Limit (dBuV/m)	Margin (dB)	Antenna	Remark
2483.5	47.79	74	26.21	H	Peak
2483.5	40.28	54	13.72	H	Average
2483.4	69.47	74	4.53	V	Peak
2483.4	50.04	54	3.96	V	Average



Mode 5: IEEE 802.11n 40MHz Link Mode

2422/H

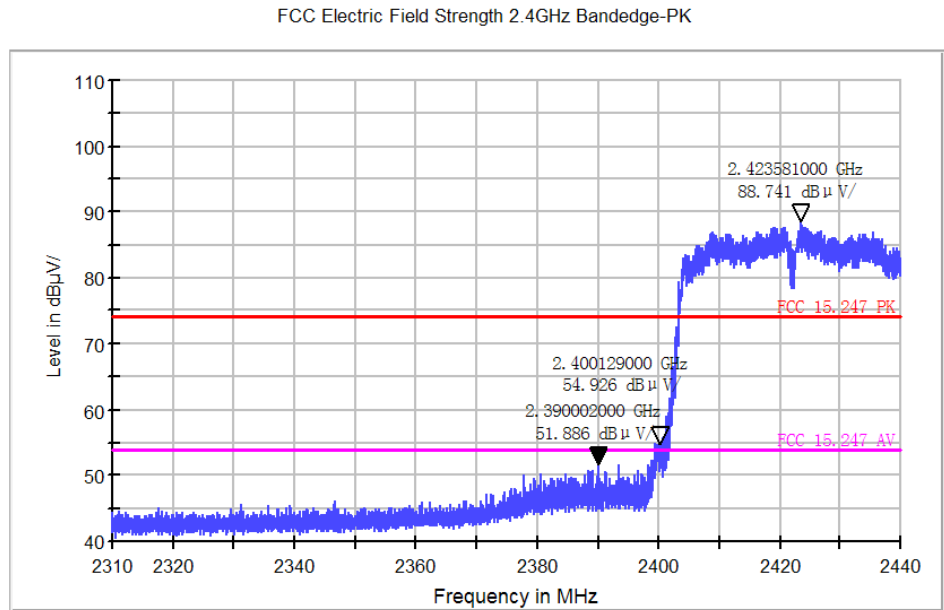

2422/V

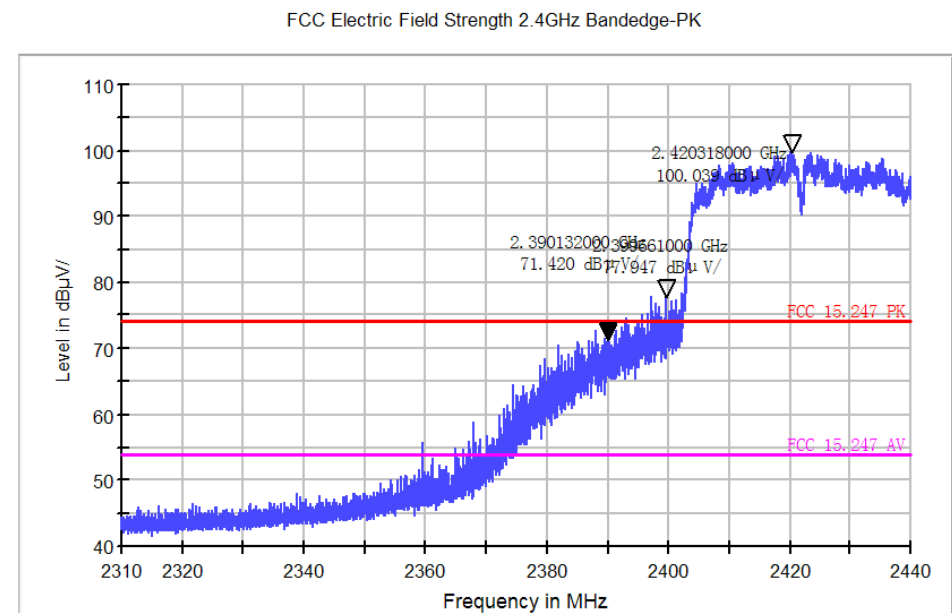

Frequency (MHz)	Result (dBuV/m)	Limit (dBuV/m)	Margin (dB)	Antenna	Remark
2400.1	54.93	74	19.07	H	Peak
2400.1	46.18	54	7.82	H	Average
2390.1	71.42	74	2.58	V	Peak
2390.1	52.03	54	1.97	V	Average



Mode 5: IEEE 802.11n 40MHz Link Mode

2452/H

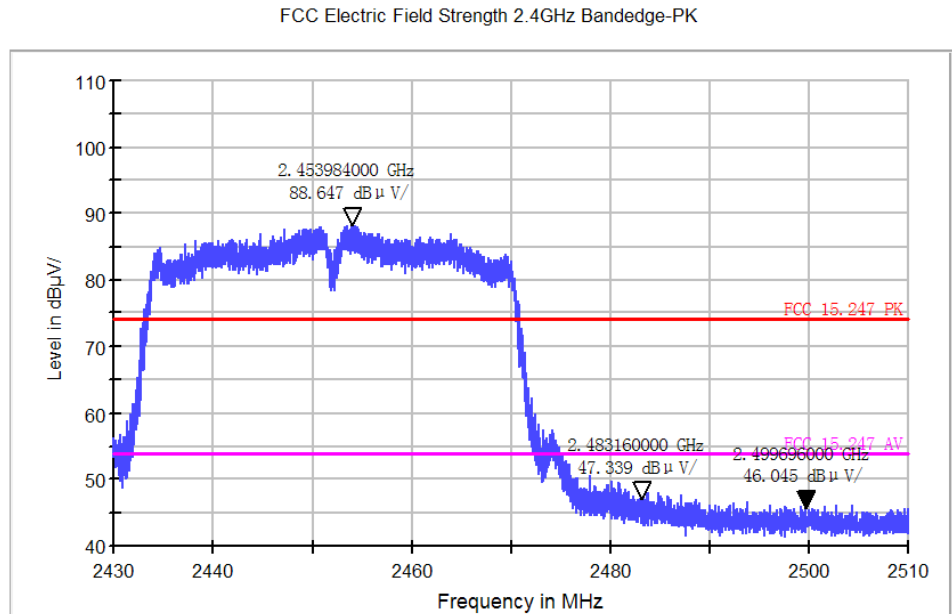

2452/V

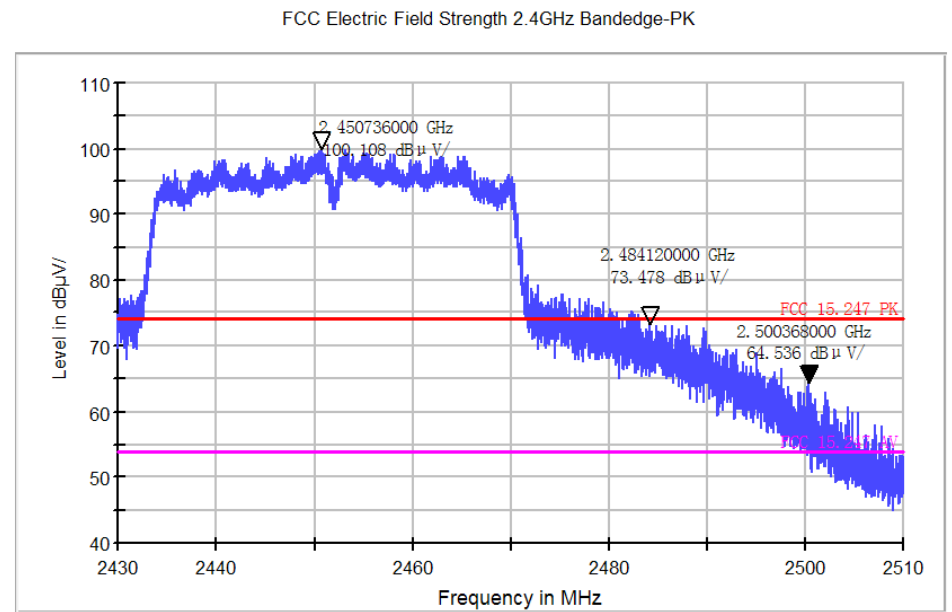

Frequency (MHz)	Result (dBuV/m)	Limit (dBuV/m)	Margin (dB)	Antenna	Remark
2483.1	47.34	74	26.66	H	Peak
2483.1	40.37	54	13.63	H	Average
2484.1	73.48	74	0.52	V	Peak
2484.1	52.05	54	1.95	V	Average



11 Antenna Measurement

11.1.Limit

For intentional device, according to 15.203, an intentional radiator shall be designed to ensure that no antenna other than that furnished by the responsible party shall be used with the device.

And According to 15.247 (b), if transmitting antennas of directional gain greater than 6 dBi are used, the power shall be reduced by the amount in dB that the directional gain of the antenna exceeds 6dBi.

11.2.Antenna Connector Construction

The antenna used of this product can be an external antenna, with 5dBi or 3dBi antenna gain, or an internal antenna with 3dBi antenna gain. So the maximum gain of these antennas is only 5.0 dBi.

11.3.Measurement Parameters

The antenna gain of the complete system is calculated by the difference of radiated power in EIRP and the conducted power of the module. For normal WLAN devices, the OFDM mode is used and used 802.11g mode.

Measurement Parameter	
Detector	Peak
Sweep time	Auto
RBW	3 MHz
VBW	10 MHz
Trace	Max hold

11.4.TEST RESULTS

ANT 0

T _{nom} /V _{nom}	Low Channel	Middle Channel	High Channel
Conducted power [dBm] Measured with OFDM modulation (802.11g)	13.62	14.23	12.97
Radiated power [dBm] Measured with OFDM modulation (802.11g)	17.84	19.10	17.42
Gain [dBi] Calculated	4.22	4.87	4.45
Measurement uncertainty	±1.5dB(Cond.)/3dB(Rad.)		



ANT 1

T_{nom}/V_{nom}	Low Channel	Middle Channel	High Channel
Conducted power [dBm] Measured with OFDM modulation (802.11g)	14.29	14.55	13.68
Radiated power [dBm] Measured with OFDM modulation (802.11g)	18.63	19.46	18.21
Gain [dBi] Calculated	4.34	4.91	4.53
Measurement uncertainty	±1.5dB(Cond.)/3dB(Rad.)		



12 Letter for Product Equality Declaration

T&W

Shenzhen Gongjin Electronics Co., Ltd
2F Nanshan Medical Instrument Industry Park 1019# Nanhai RD Shenzhen Guangdong Province
China
Tel: +86 755 26021470 Fax: +86 755 26021300

Date: 2015-3-31

Product Equality Declaration

To Whom It May Concern:

We, Shenzhen Gongjin Electronics Co., Ltd, hereby declare that our product ADSL2+ Wireless Router ,the model R5500UN (customer model name) and GAN5.PT156A-B (Gongjin model name) are electrically identical, they have the same PCB Layout and schematic, the only difference is the model name. However, there are three kinds of product form design, one is external 5dBi antenna, the second is external 3dBi antenna and the last one is internal 3dBi antenna. Compared with the external antenna sample, the internal 3dBi antenna sample adds two pieces of 800ohm TH_FBs in FB3, FB5.

If you have any question regarding this authorization, please do not hesitate to contact us.

Sincerely yours,

Signature:

Name (in print): Jimmy Li
Title: Product Manager
E-Mail: lilin2@twsz.com