

POWER SUPPLY CIRCUIT

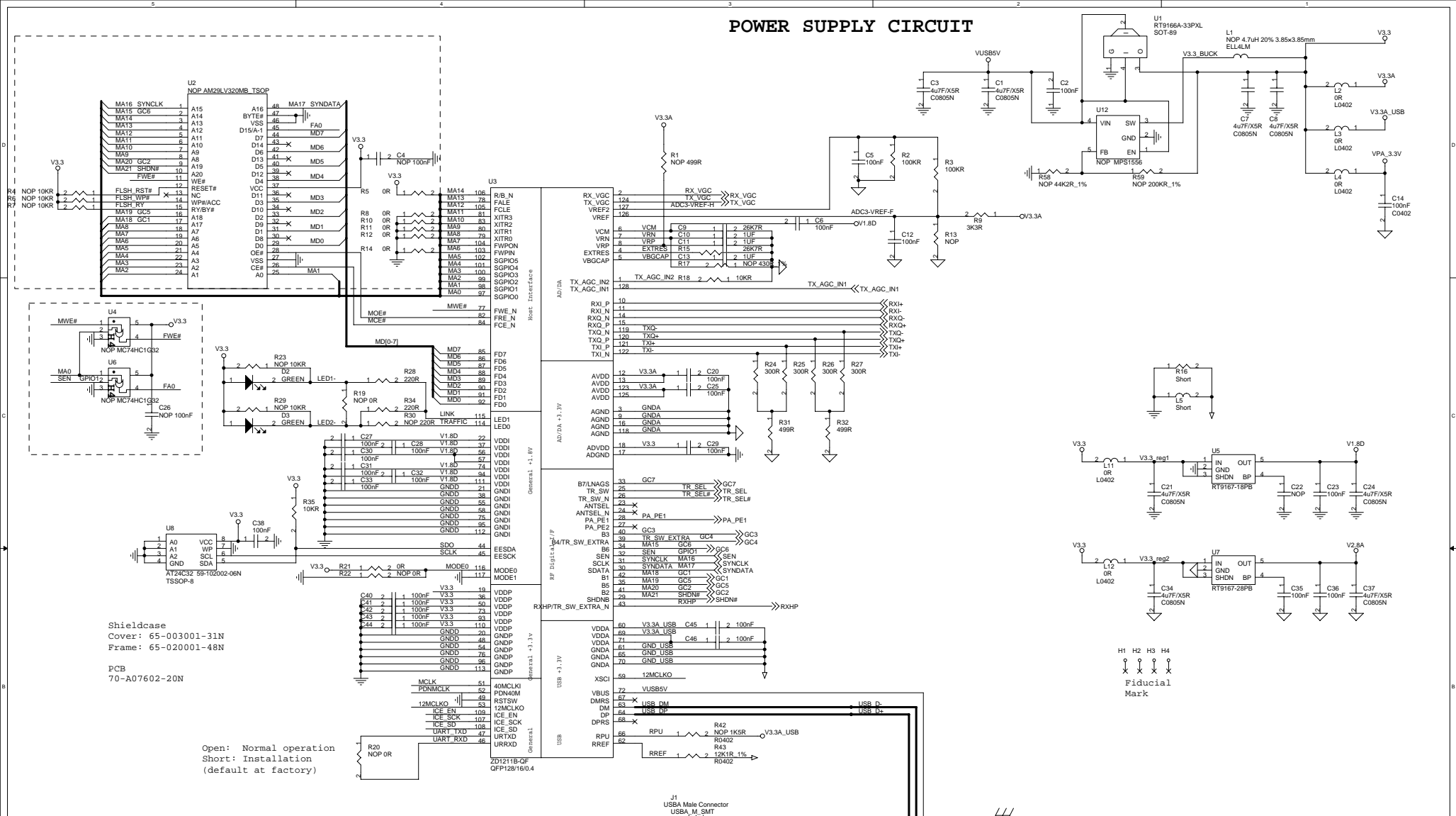

OSCILLATOR CIRCUIT FOR MAC/ RF

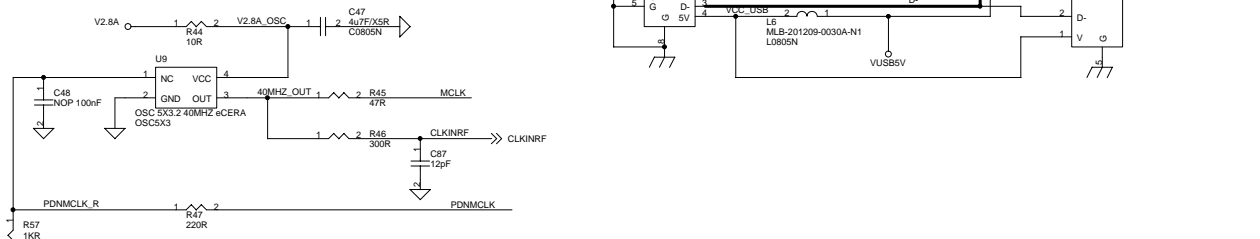

File	802.11G Zydas ZD1211B MAC/BP Circuitry	
Size	Document Number	Rev
C	ZCOM XG-760N IEEE802.11G USB Dongle	2.0
Date	Tuesday, April 18, 2006	Sheet 1 of 1

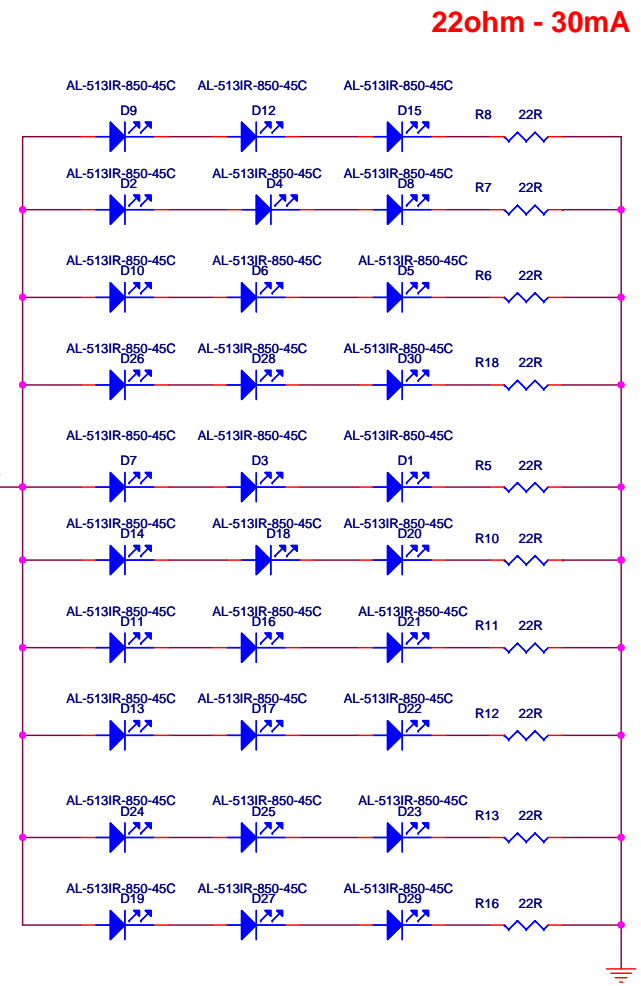
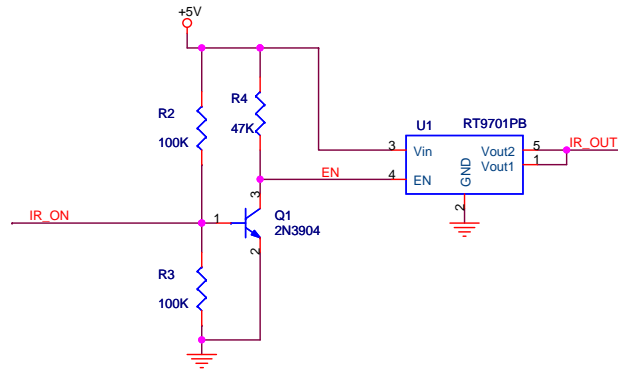
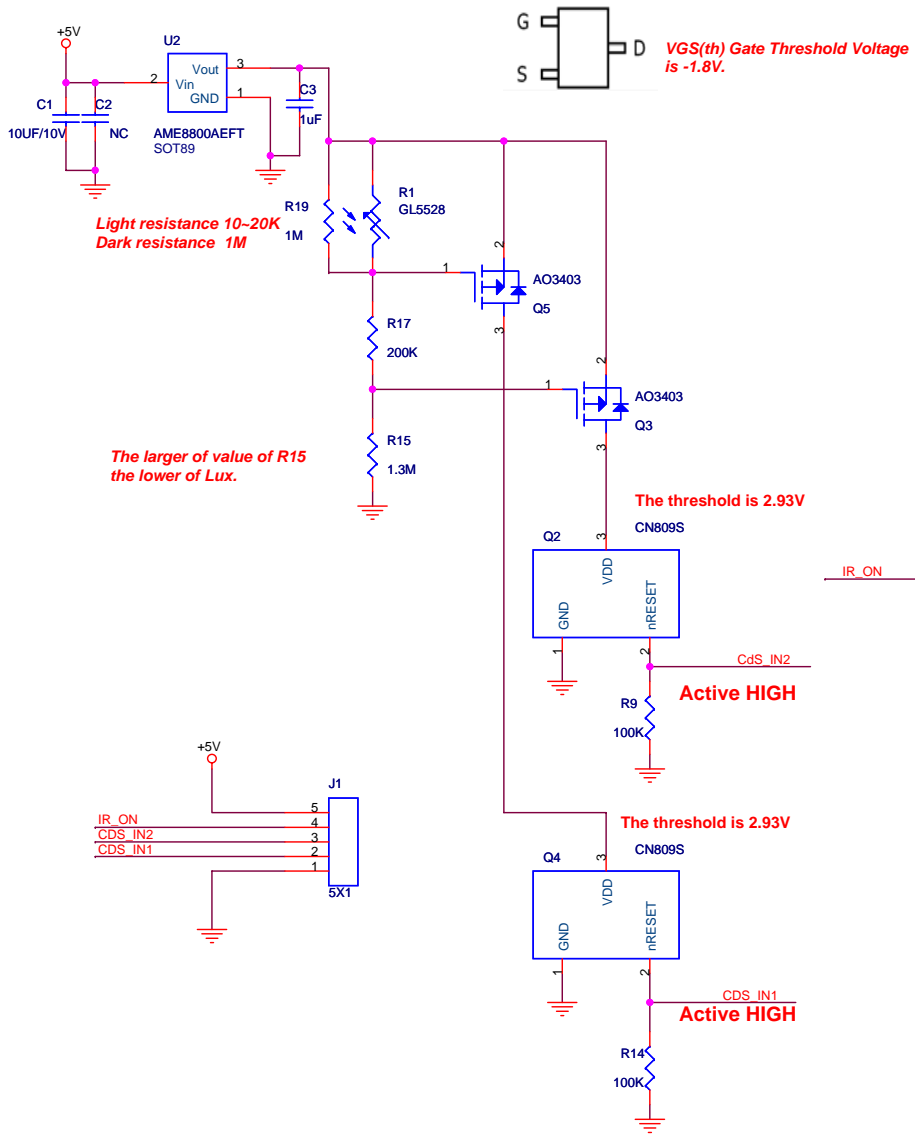

ORANTEK Co.,Ltd		
Title	IRLED	
Size	Document Number	Rev
	OT207IRLED1VB	
Date:	Thursday, January 10, 2008	Sheet 2 of 2

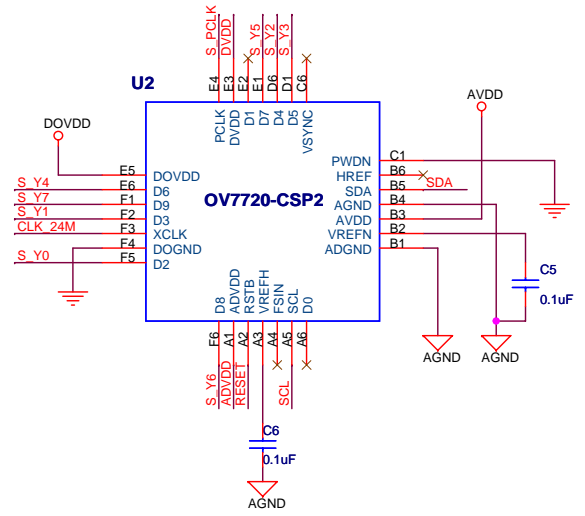
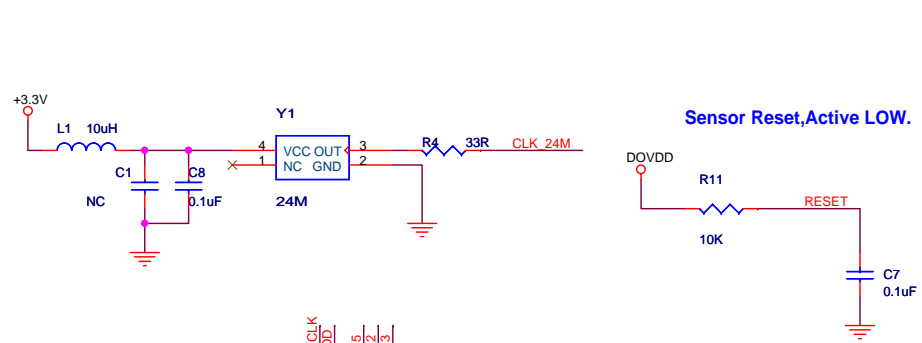

As most optical assemblies invert and mirror the image, the chip is typically mounted down on the PCB.

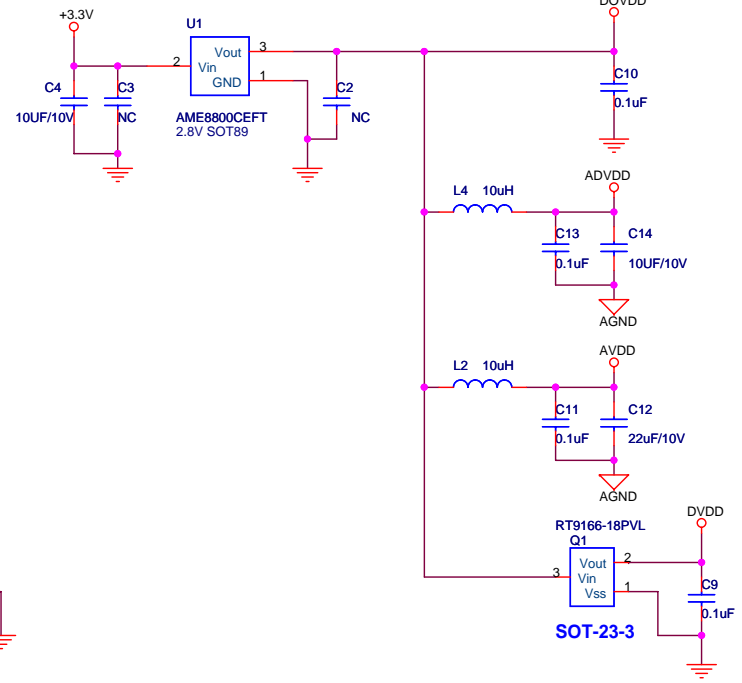
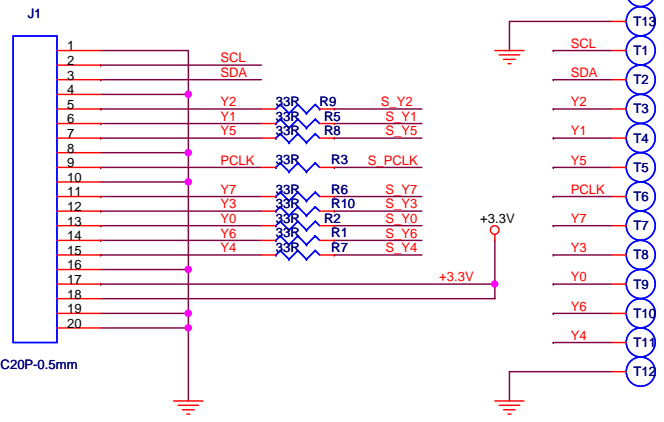
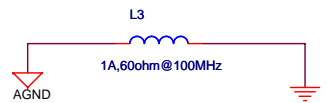

ORANTEK Co.,Ltd		
Title: OV7720		
Size:	Document Number: OT207OV77201VB	Rev: 1.0A
Date:	Monday, October 15, 2007	Sheet 2 of 2