

5

4

3

2

1

Data code/ Version	Modification
1.0	-First release

Change log:

UnRegistered

D

C

B

A

D

C

B

A

Title			
Note			
Size	Document Number		Rev
	OTIP228GM81611VA		
Date:	Thursday, June 30, 2011	Sheet	1 of 10

5

4

3

2

1

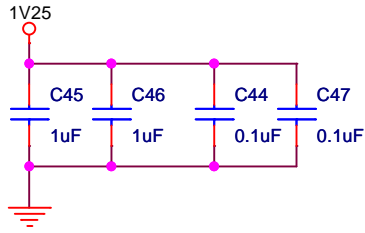

By pass cap. nearby BGA R1,T7 pin

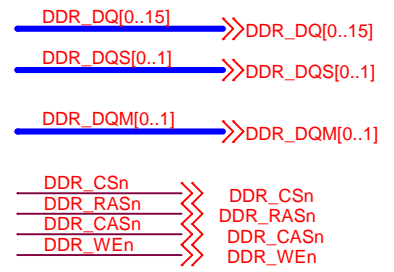
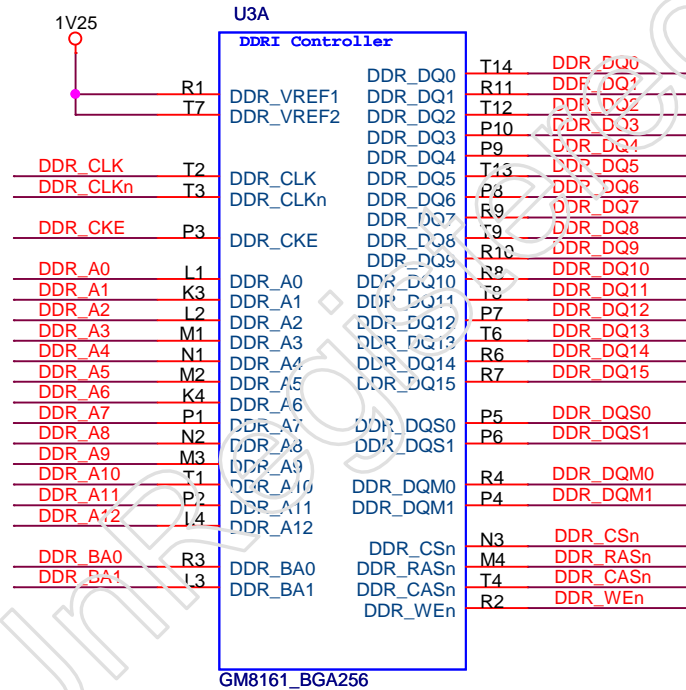
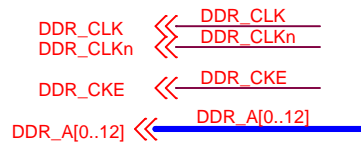

Title		
GM8161A_DDR		
Size	Document Number	Rev
	OTIP228GM81611VA	
Date:	Thursday, June 30, 2011	Sheet 1 of 9

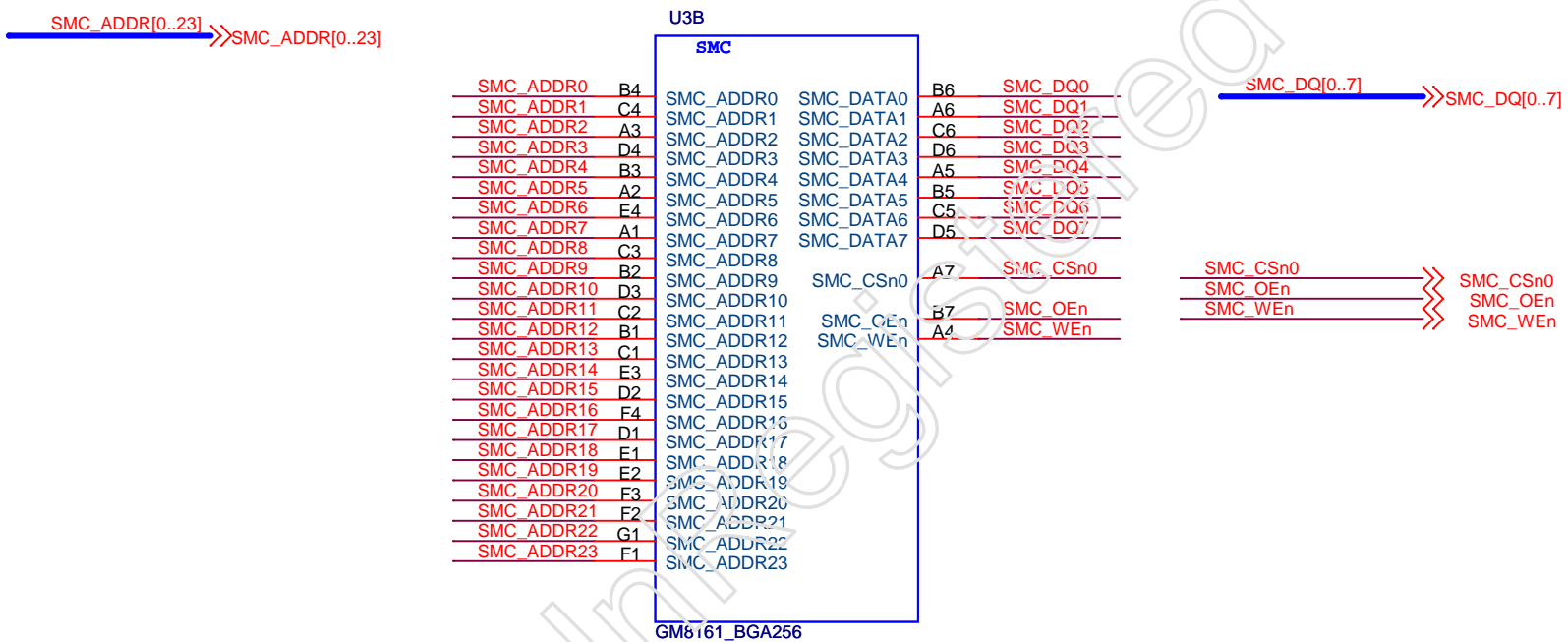

Title		
GM8161B_SMC		
Size	Document Number	Rev
	OTIP228GM81611VA	
Date:	Thursday, June 30, 2011	Sheet 2 of 9

R14 X_UART2_RTSn X_GPIO[24]

G15 X_SPI_RXD X_GPIOB[0]

E15 X_SPI_TXD X_GPIOB[1]

E14 X_SPI_SCLK X_GPIOB[2]

D15 X_SPI_FS X_GPIOB[3]

H3 X_TCK X_GPIO[12]

G2 X_TMS X_GPIO[13]

G3 X_TDO X_GPIO[14]

G4 X_TDI X_GPIO[15]

H2 X_DBGACK X_GPIO[17]

H4 X_EDBGRO X_GPIO[18]

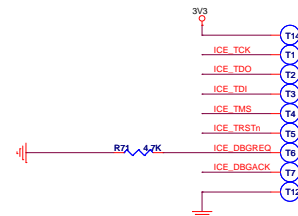
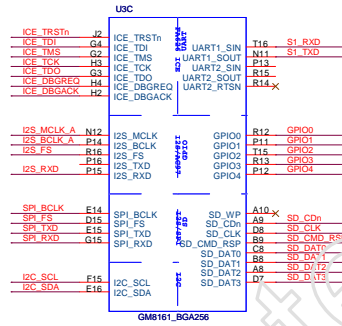
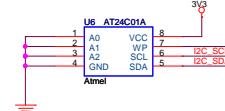
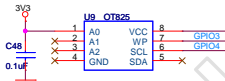
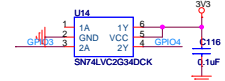

JTAG调试口，这里采用测试点的方式引出，不用考虑其摆放顺序，可以分散布局，也可以排成一排，关键是看怎样方便走线。

OSZ	Function
0	Disable
1	Enable

Default Value: 0

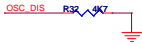

TEST_EN	Function
0	Normal
1	Test

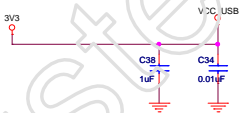
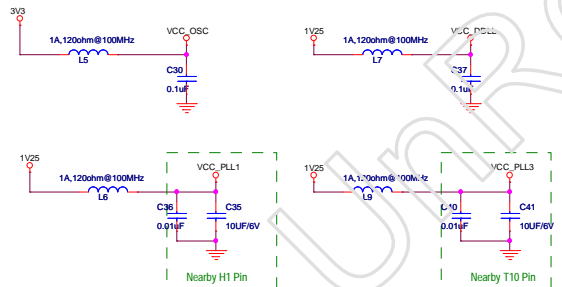
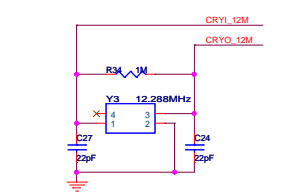
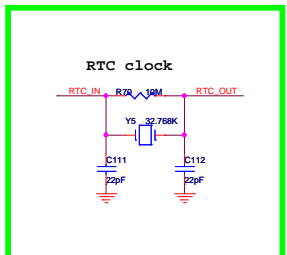
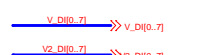
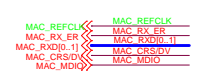
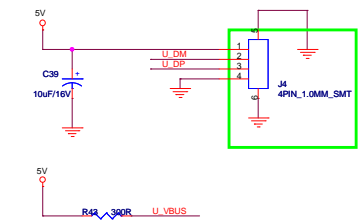
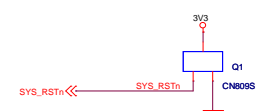
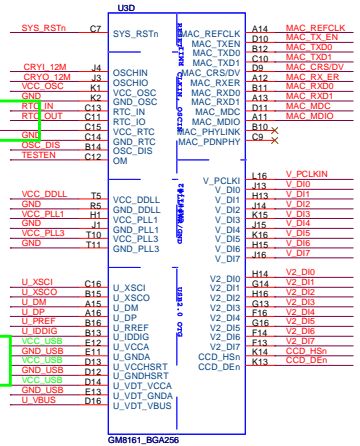
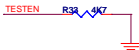

USB PHY clock

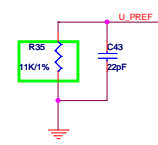
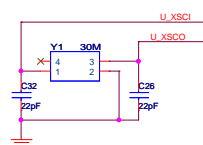

WLAN Mounting Holes

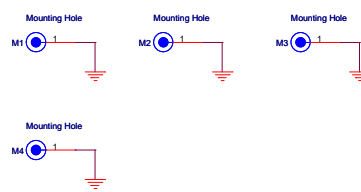

Title	GM8161D_RMIL_CLK_USB_CAP	
Size	Document Number	OTIP228GM81611VA
Date	Thursday, July 07, 2011	Sheet 2 of 8

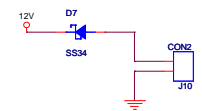
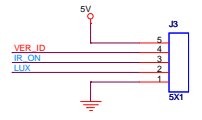
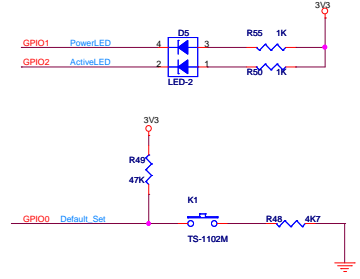
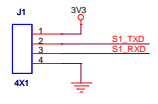
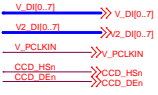
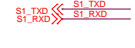

POE output interface

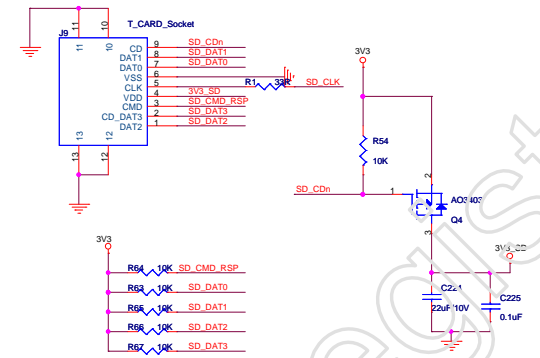

SD card socket

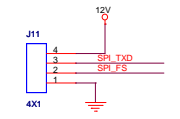

IR cut interface

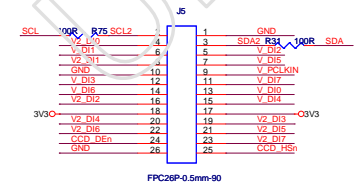

Sensor interface

Title	Connector		
Size	Document Number	OTIP228GM81611VA	
Date	Wednesday, July 06, 2011	Sheet	3 of 10

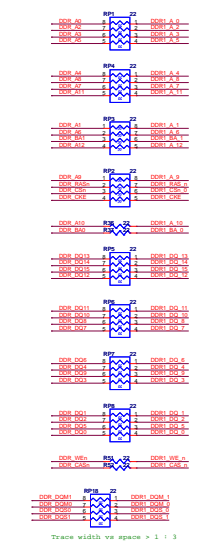
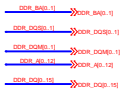

Trace width vs space > 1 : 3

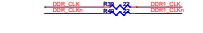

Differential Trace Impedance 100 ohms
 Trace Width 6mil
 Trace Space 15mil

512Mb(32Mx16) gDDR SDRAM

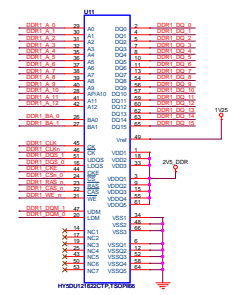

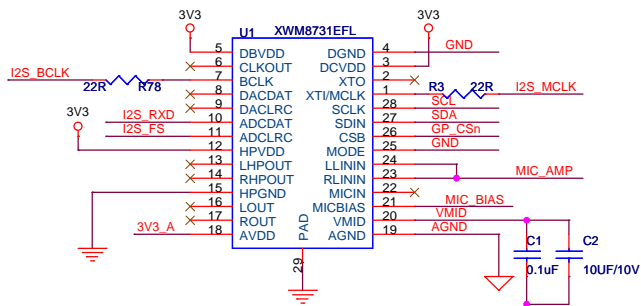

2-Wire mode address setting
 GP_CSn : 'H': 0xC4, 'L': 0xC6

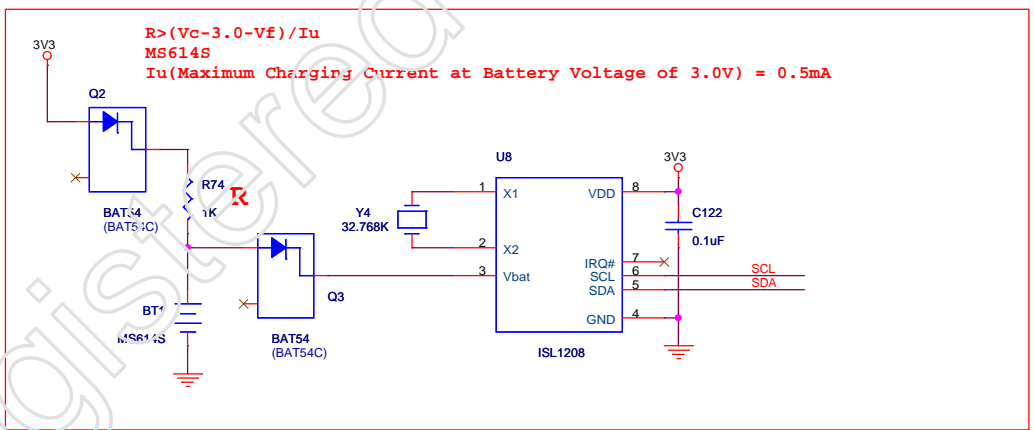
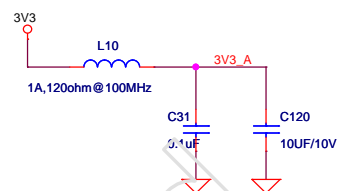
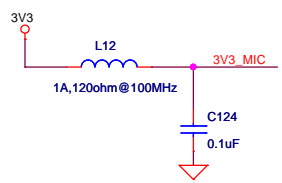
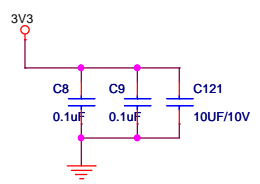
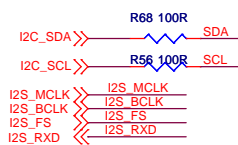

Normal Mode (VDD) to Battery Backup Mode
 To transition from the VDD to VBAT mode, both of the following conditions must be met:

- Condition 1:
 $VDD < VBAT - VBATHYS$
 where $VBATHYS \approx 50mV$
- Condition 2:
 $VDD < VTRIP$
 where $VTRIP \approx 2.2V$

Battery Backup Mode (VBAT) to Normal Mode (VDD)
 The ISL1208 device will switch from the VBAT to VDD mode when one of the following conditions occurs:

- Condition 1:
 $VDD > VBAT + VBATHYS$
 where $VBATHYS \approx 50mV$
- Condition 2:
 $VDD > VTRIP + VTRIPHYS$
 where $VTRIPHYS \approx 30mV$

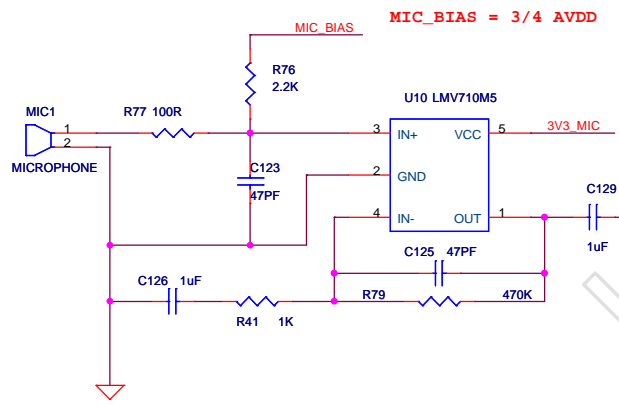

MIC_BIAS = 3/4 AVDD

ORANTEK Co.,Ltd		
Title	Audio, RTC	
Size	Document Number	Rev
	OTIP228GM81611VA	
Date:	Wednesday, July 06, 2011	Sheet 7 of 9

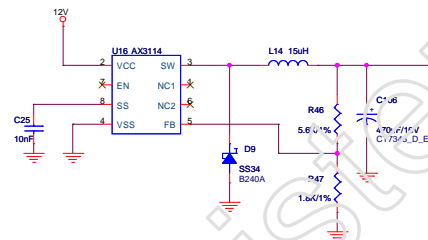
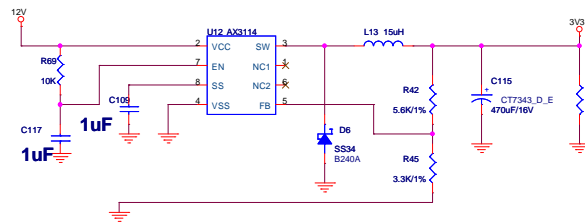
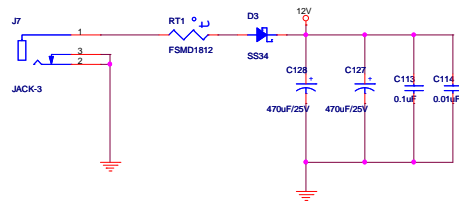

$$V_{out} = 0.6 * [1 + (R1/R2)]$$

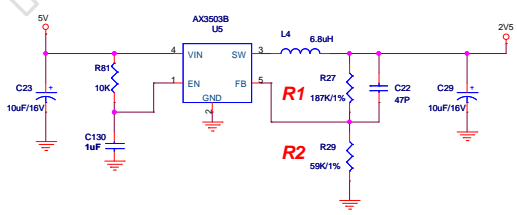
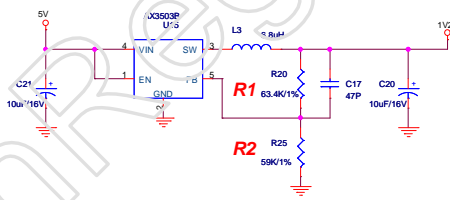

Title	Power
Size	Document Number
Date	OTIP228GM81611VA
	Wednesday, July 06, 2011
	Sheet 9 of 9