

## TEST REPORT

Test report no.: 1-3148-01-05/11



### Testing laboratory

**CETECOM ICT Services GmbH**  
Untertuerkheimer Strasse 6 – 10  
66117 Saarbruecken / Germany  
Phone: + 49 681 5 98 - 0  
Fax: + 49 681 5 98 - 9075  
Internet: <http://www.cetecom.com>  
e-mail: [ict@cetecom.com](mailto:ict@cetecom.com)

#### Accredited test laboratory:

The test laboratory (area of testing) is accredited according to DIN EN ISO/IEC 17025  
DAkkS registration number: D-PL-12076-01-01

Area of Testing: Radio/Satellite Communications

### Applicant

**AKG Acoustics GmbH**  
Lemböckgasse 21-25  
1230 Wien / AUSTRIA  
Phone: +43-1-86654-0  
Fax: +43 1 86654 1292  
Contact: Erich Gärtner  
e-mail: [erich.gaertner@harman.com](mailto:erich.gaertner@harman.com)  
Phone: +43 1 86654 1357

### Manufacturer

**VTech Communications Ltd.**  
23/F, Tai Ping Industrial Centre, Block 1  
57 Ting Kok Road, Tai Po, N.T. / Hong Kong

### Test standard/s

|                 |  |
|-----------------|--|
| 47 CFR Part 74  | Title 47 of the Code of Federal Regulations; Chapter I<br>Experimental radio, auxiliary, special broadcast and other program distribution services |
| RSS-123 Issue 2 | Spectrum Management and Telecommunications<br>Radio Standards Specification Licensed Low-Power Radio Apparatus                                     |

For further applied test standards please refer to section 3 of this test report.

### Test item

|                    |   |
|--------------------|---|
| Kind of test item: | Wireless microphone   |
| Model name:        | CSCPTX (bodypack transmitter)   |
| FCC ID:            | V3TCSCPTX   |
| IC:                | -/-   |
| Frequency:         | 500.1MHz-530.5MHz (Band VII)<br>570.1MHz-600.5MHz (Band VIII)<br>600.0MHz-605.9MHz (Band IX)<br>614.0MHz-630.5MHz (Band IX)<br>650.1MHz-680.0MHz (Band I) |
| Power supply:      | 1.5 V DC by battery   |
| Temperature range: | -20 °C to +55 °C  |



This test report is electronically signed and valid without handwriting signature. For verification of the electronic signatures, the public keys can be requested at the testing laboratory.

### Test performed:

p.o.  
Andreas Keller

### Test report authorised:

Michael Berg

**1 Table of contents**

1 Table of contents ..... 2

2 General information ..... 3

    2.1 Notes ..... 3

    2.2 Application details ..... 3

3 Test standard/s ..... 3

4 Test environment ..... 3

5 Test item ..... 4

6 Test laboratories sub-contracted ..... 4

7 Summary of measurement results ..... 5

    7.1 RSP100 test report cover sheet / performance test data ..... 6

8 RF measurements ..... 7

    8.1 Description of test setup ..... 7

        8.1.1 Radiated measurements ..... 7

        8.1.2 Conducted measurements ..... 8

    8.2 Additional comments ..... 8

9 Measurement results ..... 9

    9.1 Output power (radiated) ..... 9

    9.2 Frequency stability ..... 11

        9.2.1 Frequency error vs. temperature ..... 11

        9.2.2 Frequency error vs. voltage ..... 14

    9.3 Modulation characteristics ..... 17

    9.4 Occupied bandwidth ..... 18

    9.5 Unwanted radiation (spectrum mask) ..... 27

    9.6 Field strength of spurious radiation ..... 35

    9.7 Receiver spurious emissions (radiated) ..... 74

10 Test equipment and ancillaries used for tests ..... 75

Annex A Photographs of the test setup ..... 77

Annex B External photographs of the EUT ..... 79

Annex C Internal photographs of the EUT ..... 83

Annex D Document history ..... 89

Annex E Further information ..... 89

## 2 General information

### 2.1 Notes

The test results of this test report relate exclusively to the test item specified in this test report. CETECOM ICT Services GmbH does not assume responsibility for any conclusions and generalisations drawn from the test results with regard to other specimens or samples of the type of the equipment represented by the test item. The test report may only be reproduced or published in full. Reproduction or publication of extracts from the report requires the prior written approval of CETECOM ICT Services GmbH.

This test report is electronically signed and valid without handwriting signature. For verification of the electronic signatures, the public keys can be requested at the testing laboratory.

### 2.2 Application details

|                                    |            |
|------------------------------------|------------|
| Date of receipt of order:          | 2011-03-23 |
| Date of receipt of test item:      | 2011-03-23 |
| Start of test:                     | 2011-03-23 |
| End of test:                       | 2011-05-21 |
| Person(s) present during the test: | -/-        |

## 3 Test standard/s

| Test standard    | Version | Test standard description   |
|------------------|---------|---|
| 47 CFR Part 74   | 2009-10 | Title 47 of the Code of Federal Regulations; Chapter I<br>Experimental radio, auxiliary, special broadcast and other<br>program distribution services |
| RSS-123, Issue 2 | 2011-02 | Spectrum Management and Telecommunications<br>Radio Standards Specification Licensed Low-Power Radio<br>Apparatus                                     |

## 4 Test environment

|                            |           |                                       |
|----------------------------|-----------|---------------------------------------|
| Temperature:               | $T_{nom}$ | +22 °C during room temperature tests  |
|                            | $T_{max}$ | +55 °C during high temperature test   |
|                            | $T_{min}$ | -20 °C during low temperature test    |
| Relative humidity content: |           | 55 %                                  |
| Air pressure:              |           | not relevant for this kind of testing |
| Power supply:              | $V_{nom}$ | 1.5 V DC by battery                   |
|                            | $V_{max}$ | 1.8 V                                 |
|                            | $V_{min}$ | 1.1 V                                 |

## 5 Test item

|                      |   |  |
|----------------------|---|--|
| Kind of test item    | : | <b>Wireless microphone</b>   |
| Type identification  | : | <b>CSCPTX (bodypack transmitter)</b>   |
| S/N serial number    | : | <b>3302 H 00170 (Bd VII), 3302 H 00180 (Bd VIII), 3302 H 00210 (Bd IX),<br/>3302 H 00010 (Bd I)</b>  |
| HW hardware status   | : | <b>No information provided</b>   |
| SW software status   | : | <b>No information provided</b>   |
| Frequency band [MHz] | : | <b>500.1MHz-530.5MHz (Band VII)<br/>570.1MHz-600.5MHz (Band VIII)<br/>600.0MHz-605.9MHz (Band IX)<br/>614.1MHz-630.5MHz (Band IX)<br/>650.1MHz-680.0MHz (Band I)</b> |
| Type of modulation   | : | <b>FM</b>  |
| Number of channels   | : | <b>No information provided</b>   |
| Antenna              | : | <b>Integral rod antenna</b>  |
| Power supply         | : | <b>1.5 V DC by battery</b>   |
| Temperature range    | : | <b>-20°C to +55 °C</b>   |

## 6 Test laboratories sub-contracted

None

## 7 Summary of measurement results

- No deviations from the technical specifications were ascertained**
- There were deviations from the technical specifications ascertained

| TC Identifier | Description                            | Verdict | Date       | Remark |
|---------------|--|---------|------------|--------|
| RF-Testing    | FCC 47 CFR § 74.861<br>RSS-123 Issue 2 | PASSED  | 2011-06-17 | -/-    |

| Test Specification Clause                              | Test Case  | Temperature Conditions | Power Source Voltages | Pass                                | Fail                     | NA                                  | NP                       | Results (max.) |
|--|--|------------------------|-----------------------|-------------------------------------|--------------------------|-------------------------------------|--------------------------|----------------|
| FCC 47 CFR § 74.861 (e)(1)(ii)<br>RSS-123 §6.2 Issue 2 | Output power (radiated)  | Nominal                | Nominal               | <input checked="" type="checkbox"/> | <input type="checkbox"/> | <input type="checkbox"/>            | <input type="checkbox"/> | complies       |
| FCC 47 CFR § 74.861<br>RSS-123 §7 Issue 2              | Frequency stability  | Nominal                | Extreme               | <input checked="" type="checkbox"/> | <input type="checkbox"/> | <input type="checkbox"/>            | <input type="checkbox"/> | complies       |
|  |  | Extreme                | Nominal               | <input checked="" type="checkbox"/> | <input type="checkbox"/> | <input type="checkbox"/>            | <input type="checkbox"/> |                |
| FCC 47 CFR § 2.1049 § 74.861                           | Modulation characteristics   | Nominal                | Nominal               | <input checked="" type="checkbox"/> | <input type="checkbox"/> | <input type="checkbox"/>            | <input type="checkbox"/> | complies       |
| FCC 47 CFR § 2.1049 § 74.861<br>RSS-123 §6 Issue 2     | Occupied bandwidth   | Nominal                | Nominal               | <input checked="" type="checkbox"/> | <input type="checkbox"/> | <input type="checkbox"/>            | <input type="checkbox"/> | complies       |
| FCC 47 CFR § 74.861                                    | Unwanted radiation (spectrum mask)                                     | Nominal                | Nominal               | <input checked="" type="checkbox"/> | <input type="checkbox"/> | <input type="checkbox"/>            | <input type="checkbox"/> | complies       |
| FCC 47 CFR § 74<br>RSS-123 Issue 2                     | Field strength of spurious radiation<br>Transmitter unwanted emissions | Nominal                | Nominal               | <input checked="" type="checkbox"/> | <input type="checkbox"/> | <input type="checkbox"/>            | <input type="checkbox"/> | complies       |
| FCC 47 CFR § 15.209<br>RSS-123 Issue 2                 | Receiver spurious emissions (radiated)                                 | Nominal                | Nominal               | <input type="checkbox"/>            | <input type="checkbox"/> | <input checked="" type="checkbox"/> | <input type="checkbox"/> | complies       |

**Note:** NA = Not Applicable; NP = Not Performed

## 7.1 RSP100 test report cover sheet / performance test data

|  |   |   |
|--|---|---|
| Test Report Number                             | : | 1-3148-01-05/11   |
| Equipment Model Number                         | : | CSCPTX (bodypack transmitter)   |
| Certification Number                           | : | -/-   |
| Manufacturer (complete Address)                | : | VTech Communications Ltd.<br>23/F, Tai Ping Industrial Centre, Block 1<br>57 Ting Kok Road, Tai Po, N.T. / Hong Kong  |
| Tested to radio standards specification no.    | : | RSS-123 Issue 2   |
| Open Area Test Site IC No.                     | : | IC 3462C-1  |
| Frequency Range or fixed frequency             | : | 500.1MHz-530.5MHz (Band VII)<br>570.1MHz-600.5MHz (Band VIII)<br>600.0MHz-605.9MHz (Band IX)<br>614.1MHz-630.5MHz (Band IX)<br>650.1MHz-680.0MHz (Band I)   |
| Max, radiated output power [dBm]               | : | 500.1MHz-530.5MHz (Band VII) = 13.9<br>570.1MHz-600.5MHz (Band VIII) = 15.0<br>600.0MHz-605.9MHz (Band IX) = 12.8<br>614.1MHz-630.5MHz (Band IX) = 13.9<br>650.1MHz-680.0MHz (Band I) = 14.7                |
| Occupied bandwidth (99%-BW) [kHz]              | : | 500.1MHz-530.5MHz (Band VII) = 126<br>570.1MHz-600.5MHz (Band VIII) = 126<br>600.0MHz-605.9MHz (Band IX) = 126<br>614.1MHz-630.5MHz (Band IX) = 130<br>650.1MHz-680.0MHz (Band I) = 128                     |
| Type of modulation                             | : | FM  |
| Emission Designator (TRC-43)                   | : | 500.1MHz-530.5MHz (Band VII) = 126kF3E<br>570.1MHz-600.5MHz (Band VIII) = 126kF3E<br>600.0MHz-605.9MHz (Band IX) = 126kF3E<br>614.1MHz-630.5MHz (Band IX) = 130kF3E<br>650.1MHz-680.0MHz (Band I) = 128kF3E |
| Antenna Information                            | : | Integral rod antenna  |
| Transmitter Spurious (worst case) [ $\mu$ W] : |   | 2.14 $\mu$ W @ 4413.5 MHz   |
| Receiver Spurious (worst case) [ $\mu$ W] :    |   | No receiver / idle mode   |

### ATTESTATION:

### DECLARATION OF COMPLIANCE:

I attest that the testing was performed or supervised by me; that the test measurements were made in accordance with the above-mentioned Industry Canada standard(s); and that the equipment identified in this application has been subjected to all the applicable test conditions specified in the Industry Canada standards and all of the requirements of the standard have been met.

### Laboratory Manager:

2011-06-17

Andreas Keller

p.o.

Date

Name

Signature

## 8 RF measurements

### 8.1 Description of test setup

#### 8.1.1 Radiated measurements

The radiated measurements are performed in vertical and horizontal plane in the frequency range from 9 kHz to 25 GHz in semi-anechoic chambers. The EUT is positioned on a non-conductive support with a height of 0.80 m above a conductive ground plane that covers the whole chamber. The receiving antennas are confirmed with specifications ANSI C63.2-1996 clause 15 and ANSI C63.4-2009 clause 4.1.5. These antennas can be moved over the height range between 1.0 m and 4.0 m in order to search for maximum field strength emitted from EUT. The measurement distances between EUT and receiving antennas are indicated in the test setups for the various frequency ranges. For each measurement, the EUT is rotated in all three axes until the maximum field strength is received. The wanted and unwanted emissions are received by spectrum analysers where the detector modes and resolution bandwidths over various frequency ranges are set according to requirement ANSI C63-4-2009 clause 4.2.

Antennas are confirmed with ANSI C63.2-1996 item 15.

Semi anechoic chamber

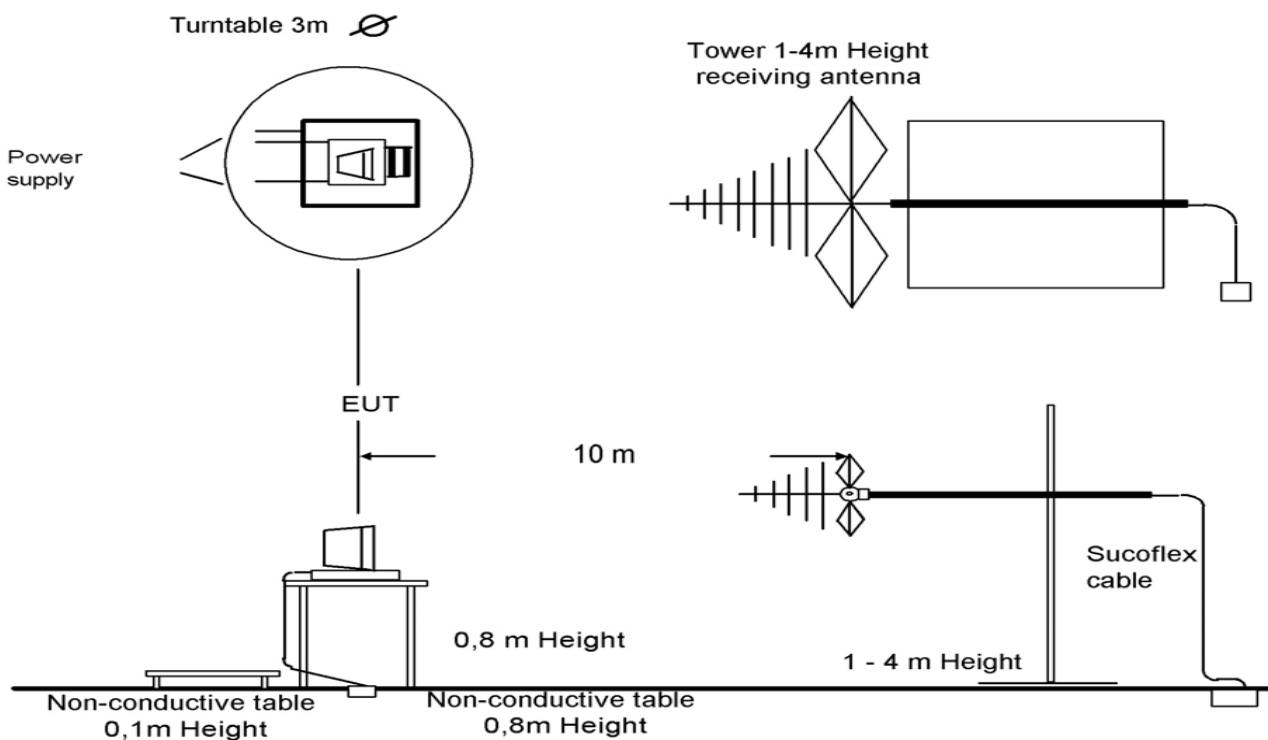

Picture 1: Diagram radiated measurements

|                 |                     |
|-----------------|---------------------|
| 9 kHz - 30 MHz: | active loop antenna |
| 30 MHz – 1 GHz: | tri-log antenna     |
| > 1 GHz:        | horn antenna        |

The EUT is powered by an external power supply with nominal voltage. The signalling is performed from outside the chamber with a signalling unit (CMU200 or other) by air link using signalling antenna.

## 8.1.2 Conducted measurements

The EUT's RF signal is coupled out by the antenna connector which is supplied by the manufacturer. The signal is first 10dB attenuated before it is power divided (~6dB loss per branch). One of the signal paths is connected to the communication base Station (CMU200 or other), the other one is connected to the spectrum analyzer. The specific losses for both signal paths are first checked within a calibration. The measurement readings on the signalling unit/spectrum analyzer are corrected by the specific test set-up loss. The attenuator, power divider, signalling unit and the spectrum analyzer are impedance matched on 50 Ohm.

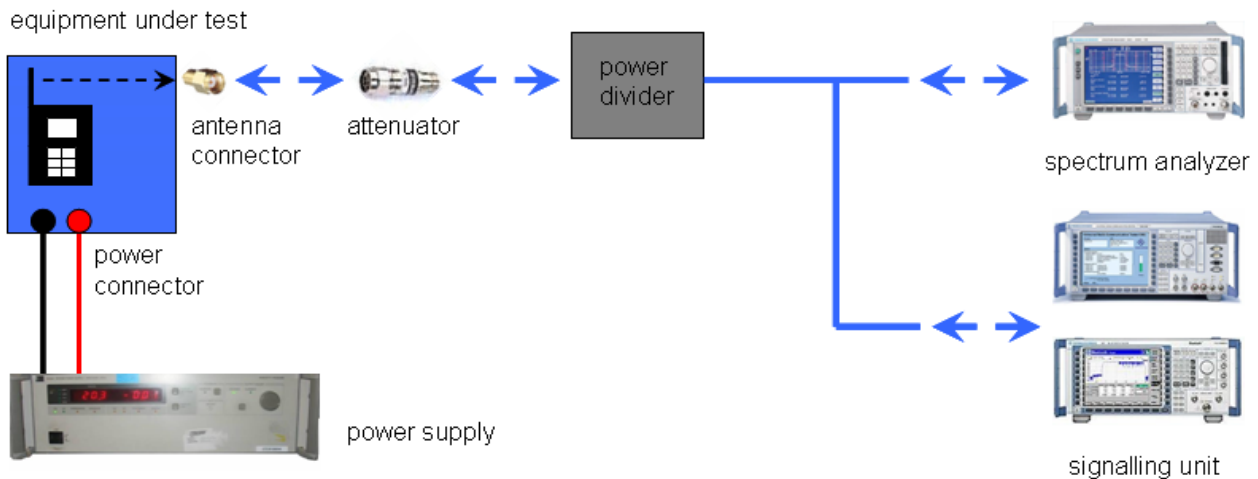

Picture 2: Diagram conducted measurements

## 8.2 Additional comments

Reference documents: WMS470, User instructions (V1.00), 12/10/9100 U 11350

Special test descriptions: CSCPTX (PT470 bodypack transmitter)

Configuration descriptions: None

The manufacturers declared nominal/maximal deviation: 40 kHz / 55 kHz.

The transmitter don't have any standby or idle mode.

For frequency error measurements especially connectorized samples were provided.

Output power and spurious emissions

Tested frequencies Band VII (500.1MHz-530.5MHz): 500.1MHz/515.3MHz/530.5MHz

Tested frequencies Band VIII (570.1MHz-600.5MHz): 570.1MHz/585.3MHz/600.5MHz

Tested frequencies Band IX (600.0MHz-605.9MHz): 600.0MHz/605.9MHz

Tested frequencies Band IX (614.1MHz-630.5MHz): 614.1MHz/622.25MHz/630.5MHz

Tested frequencies Band I (650.1MHz-680.0MHz): 650.1MHz/665.05MHz/680.0MHz



## 9 Measurement results

### 9.1 Output power (radiated)

#### Measurement:

| Measurement parameter |           |
|-----------------------|-----------|
| Detector:             | Peak      |
| Sweep time:           | Auto      |
| Resolution bandwidth: | 1MHz      |
| Video bandwidth:      | 1MHz      |
| Span:                 | ZERO      |
| Trace-Mode:           | Max. hold |

#### Limits:

| FCC   | IC                   |
|---|----------------------|
| 47 CFR § 74.861 (e)(1)(ii)                      | RSS-123 §6.2 Issue 2 |
| Maximum transmitter power                       |                      |
| 470-608 and 614-698MHz bands - 250mW (23.98dBm) |                      |

**Result:**

Band VII (500.1MHz-530.5MHz):

| Frequency (channel) | Radiated output power |
|---------------------|-----------------------|
| 500.1 MHz           | +13.9 dBm             |
| 515.3 MHz           | +13.7 dBm             |
| 530.5 MHz           | +13.9 dBm             |

Band VIII (570.1MHz-600.5MHz):

| Frequency | Radiated output power |
|-----------|-----------------------|
| 570.1 MHz | +15.0 dBm             |
| 585.3 MHz | +13.8 dBm             |
| 600.5 MHz | +11.5 dBm             |

Band IX (600.0MHz-605.9MHz):

| Frequency | Radiated output power |
|-----------|-----------------------|
| 600.0 MHz | +12.6 dBm             |
| 605.9 MHz | +12.8 dBm             |

Band IX (614.1MHz-630.5MHz):

| Frequency  | Radiated output power |
|------------|-----------------------|
| 614.1 MHz  | +12.0 dBm             |
| 622.25 MHz | +12.0 dBm             |
| 630.5 MHz  | +13.9 dBm             |

Band I (650.1MHz-680.0MHz):

| Frequency  | Radiated output power |
|------------|-----------------------|
| 650.1 MHz  | +14.1 dBm             |
| 665.05 MHz | +14.7 dBm             |
| 680.0 MHz  | +14.6 dBm             |

**Result:** The result of the measurement is passed.

**9.2 Frequency stability**

**9.2.1 Frequency error vs. temperature**

**Measurement:**

| Measurement parameter |            |
|-----------------------|------------|
| Frequency counter     | R&S CMTA84 |

**Limits:**

| FCC   | IC                 |
|---|--------------------|
| 47 CFR § 74.861   | RSS-123 §7 Issue 2 |
| The frequency tolerance of the transmitter shall be 0.005 percent (50ppm) |                    |

**Results:**

Band VII (500.1MHz-530.5MHz):

| Temperature | Frequency (MHz) | Deviation (kHz / ppm) |
|-------------|-----------------|-----------------------|
| -30 °C      | 515.3           | -11.6 / -23           |
| -20 °C      | 515.3           | -7.2 / -14            |
| -10 °C      | 515.3           | -6.7 / -13            |
| 0 °C        | 515.3           | -5.8 / -11            |
| 10 °C       | 515.3           | -5.8 / -11            |
| 20 °C       | 515.3           | -6.4 / -12            |
| 30 °C       | 515.3           | -6.9 / -13            |
| 40 °C       | 515.3           | -7.4 / -14            |
| 50 °C       | 515.3           | -7.7 / -15            |

Band VIII (570.1MHz-600.5MHz):

| Temperature | Frequency (MHz) | Deviation (kHz / ppm) |
|-------------|-----------------|-----------------------|
| -30 °C      | 585.3           | -2.6 / -4             |
| -20 °C      | 585.3           | 0.0 / 0               |
| -10 °C      | 585.3           | +0.7 / 1              |
| 0 °C        | 585.3           | +0.5 / 1              |
| 10 °C       | 585.3           | -0.2 / 0              |
| 20 °C       | 585.3           | -3.2 / -5             |
| 30 °C       | 585.3           | -3.6 / -6             |
| 40 °C       | 585.3           | -5.3 / -9             |
| 50 °C       | 585.3           | -6.5 / -11            |

Band IX (600.0MHz-630.5MHz):

| Temperature | Frequency (MHz) | Deviation (kHz / ppm) |
|-------------|-----------------|-----------------------|
| -30 °C      | 620.65          | -3.0 / -5             |
| -20 °C      | 620.65          | +0.3 / 0              |
| -10 °C      | 620.65          | +1.4 / 2              |
| 0 °C        | 620.65          | +1.2 / 2              |
| 10 °C       | 620.65          | +0.2 / 0              |
| 20 °C       | 620.65          | -2.9 / -5             |
| 30 °C       | 620.65          | -3.5 / -6             |
| 40 °C       | 620.65          | -5.3 / -9             |
| 50 °C       | 620.65          | -6.8 / -11            |

Band I (650.1MHz-680.0MHz):

| Temperature | Frequency (MHz) | Deviation (kHz / ppm) |
|-------------|-----------------|-----------------------|
| -30 °C      | 665.05          | -1.5 / -2             |
| -20 °C      | 665.05          | +1.6 / 2              |
| -10 °C      | 665.05          | +3.0 / 5              |
| 0 °C        | 665.05          | +3.4 / 5              |
| 10 °C       | 665.05          | +2.6 / 4              |
| 20 °C       | 665.05          | -0.3 / 0              |
| 30 °C       | 665.05          | -0.6 / -1             |
| 40 °C       | 665.05          | -2.8 / -4             |
| 50 °C       | 665.05          | -4.5 / -7             |

**Result:** The result of the measurement is passed.

**9.2.2 Frequency error vs. voltage**

**Measurement:**

| Measurement parameter |            |
|-----------------------|------------|
| Frequency counter     | R&S CMTA84 |
| Temperature           | 22°C       |

**Limits:**

| FCC   | IC                 |
|---|--------------------|
| 47 CFR § 74.861   | RSS-123 §7 Issue 2 |
| The frequency tolerance of the transmitter shall be 0.005 percent (50ppm) |                    |

**Results:**

Band VII (500.1MHz-530.5MHz):

| Voltage | Frequency (MHz) | Deviation (kHz / ppm) |
|---------|-----------------|-----------------------|
| 1.1 V   | 515.3           | -6.4 / -12            |
| 1.2 V   | 515.3           | -6.4 / -12            |
| 1.3 V   | 515.3           | -6.4 / -12            |
| 1.4 V   | 515.3           | -6.5 / -13            |
| 1.5 V   | 515.3           | -6.4 / -12            |
| 1.6 V   | 515.3           | -6.4 / -12            |
| 1.7 V   | 515.3           | -6.4 / -12            |
| 1.8 V   | 515.3           | -6.4 / -12            |

Band VIII (570.1MHz-600.5MHz):

| Voltage | Frequency (MHz) | Deviation (kHz / ppm) |
|---------|-----------------|-----------------------|
| 1.1 V   | 585.3           | -3.1 / -5             |
| 1.2 V   | 585.3           | -3.2 / -6             |
| 1.3 V   | 585.3           | -3.2 / -6             |
| 1.4 V   | 585.3           | -3.2 / -6             |
| 1.5 V   | 585.3           | -3.2 / -6             |
| 1.6 V   | 585.3           | -3.1 / -5             |
| 1.7 V   | 585.3           | -3.1 / -5             |
| 1.8 V   | 585.3           | -3.2 / -6             |

Band IX (600.0MHz-630.5MHz):

| Voltage | Frequency (MHz) | Deviation (kHz / ppm) |
|---------|-----------------|-----------------------|
| 1.1 V   | 620.65          | -2.9 / -5             |
| 1.2 V   | 620.65          | -2.9 / -5             |
| 1.3 V   | 620.65          | -2.9 / -5             |
| 1.4 V   | 620.65          | -2.9 / -5             |
| 1.5 V   | 620.65          | -2.9 / -5             |
| 1.6 V   | 620.65          | -2.9 / -5             |
| 1.7 V   | 620.65          | -2.9 / -5             |
| 1.8 V   | 620.65          | -2.9 / -5             |

Band I (650.1MHz-680.0MHz):

| Voltage | Frequency (MHz) | Deviation (kHz / ppm) |
|---------|-----------------|-----------------------|
| 1.1 V   | 665.05          | -0.3 / -1             |
| 1.2 V   | 665.05          | -0.4 / -1             |
| 1.3 V   | 665.05          | -0.4 / -1             |
| 1.4 V   | 665.05          | -0.3 / -1             |
| 1.5 V   | 665.05          | -0.3 / -1             |
| 1.6 V   | 665.05          | -0.3 / -1             |
| 1.7 V   | 665.05          | -0.3 / -1             |
| 1.8 V   | 665.05          | -0.3 / -1             |

**Result:** The result of the measurement is passed.



### 9.3 Modulation characteristics

**Measurement:**

| FCC                                | IC  |
|------------------------------------|-----|
| 47 CFR § 2.1047<br>47 CFR § 74.861 | -/- |

**Method of measurement:**

The audio frequency responds was measured in accordance with EIA/TIA 603. The plots shows 10 curves with different modulation levels, the frequency is varied from 15 Hz to 20 kHz.

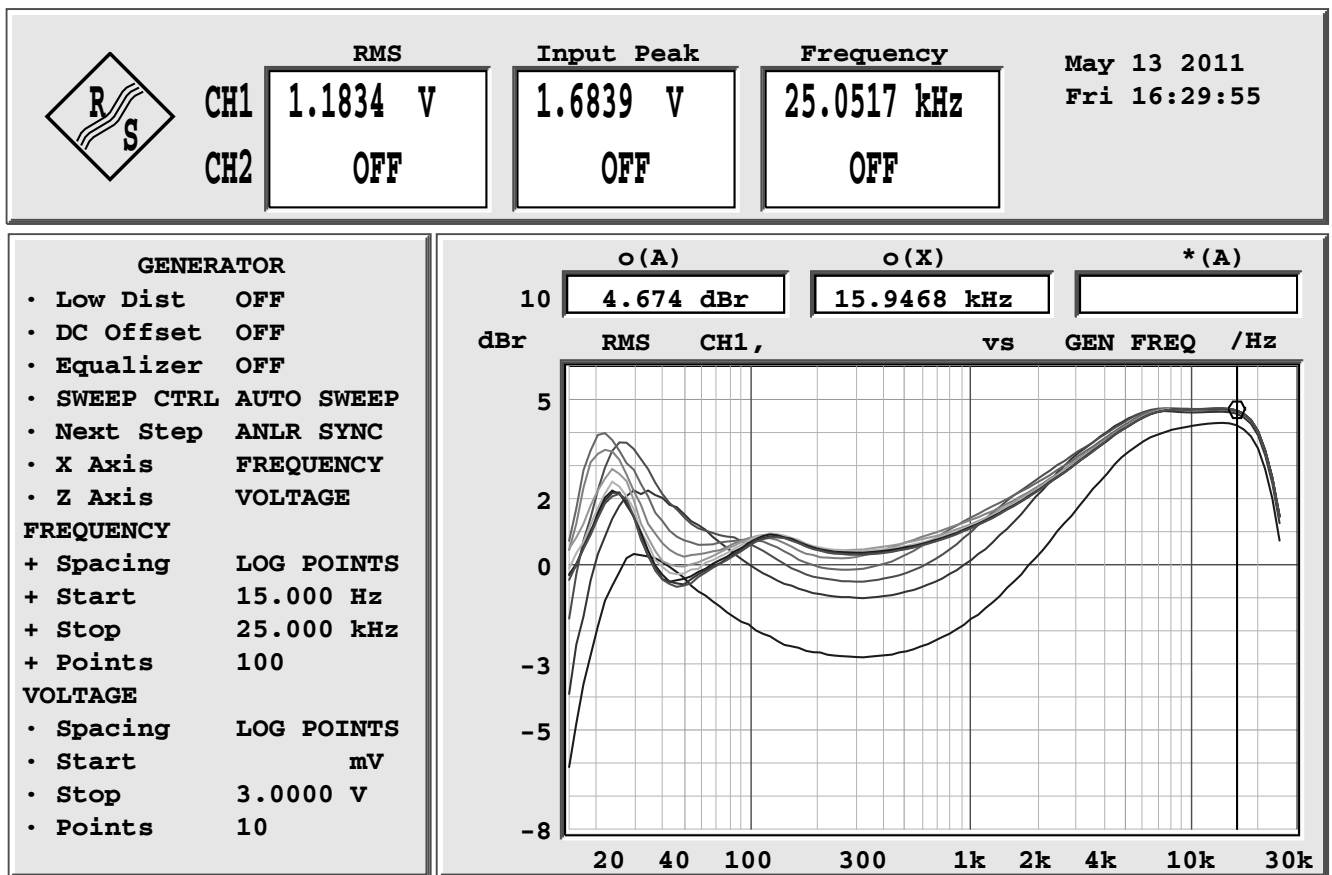

## 9.4 Occupied bandwidth

**Measurement:**

| Measurement parameter |           |
|-----------------------|-----------|
| Detector:             | Peak      |
| Sweep time:           | Auto      |
| Resolution bandwidth: | 3 kHz     |
| Video bandwidth:      | 3 kHz     |
| Span:                 | 1 MHz     |
| Trace-Mode:           | Max. hold |

**Limits:**

| FCC  | IC                 |
|--|--------------------|
| 47 CFR § 74.861 (e) (3)                          | RSS-123 §5 Issue 2 |
| Occupied bandwidth 99%.                          |                    |
| The operating bandwidth shall not exceed 200 kHz |                    |

**Result:**

Band VII (500.1MHz-530.5MHz):

| Frequency | 20dB Bandwidth |
|-----------|----------------|
| 500.1 MHz | 108 kHz        |
| 515.3 MHz | 120 kHz        |
| 530.5 MHz | 126 kHz        |

Band VIII (570.1MHz-600.5MHz):

| Frequency | 20dB Bandwidth |
|-----------|----------------|
| 570.1 MHz | 126 kHz        |
| 585.3 MHz | 126 kHz        |
| 600.5 MHz | 126 kHz        |

Band IX (600.0MHz-605.9MHz):

| Frequency | 20dB Bandwidth |
|-----------|----------------|
| 600.0 MHz | 126 kHz        |
| 605.9 MHz | 126 kHz        |

Band IX (614.1MHz-630.5MHz):

| Frequency  | 20dB Bandwidth |
|------------|----------------|
| 614.1 MHz  | 130 kHz        |
| 622.25 MHz | 124 kHz        |
| 630.5 MHz  | 118 kHz        |

Band I (650.1MHz-680.0MHz):

| Frequency  | 20dB Bandwidth |
|------------|----------------|
| 650.1 MHz  | 128 kHz        |
| 665.05 MHz | 126 kHz        |
| 680.0 MHz  | 128 kHz        |

**Result:** The result of the measurement is passed.

Plots of the measurements

Plot 1: Band VII (500.1MHz-530.5MHz) low channel

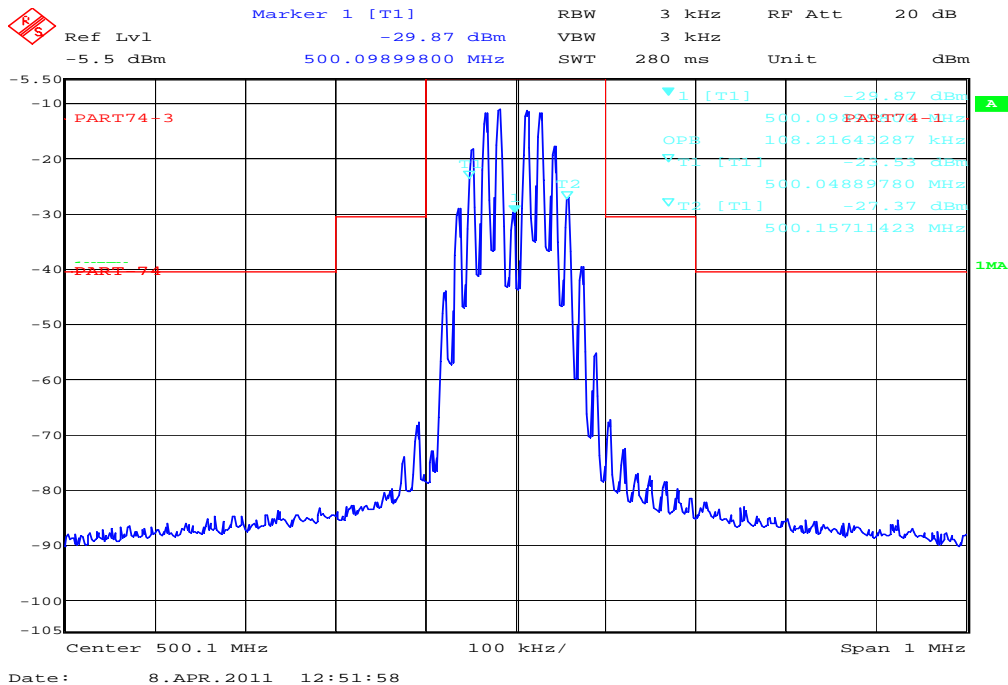

Plot 2: Band VII (500.1MHz-530.5MHz) middle channel

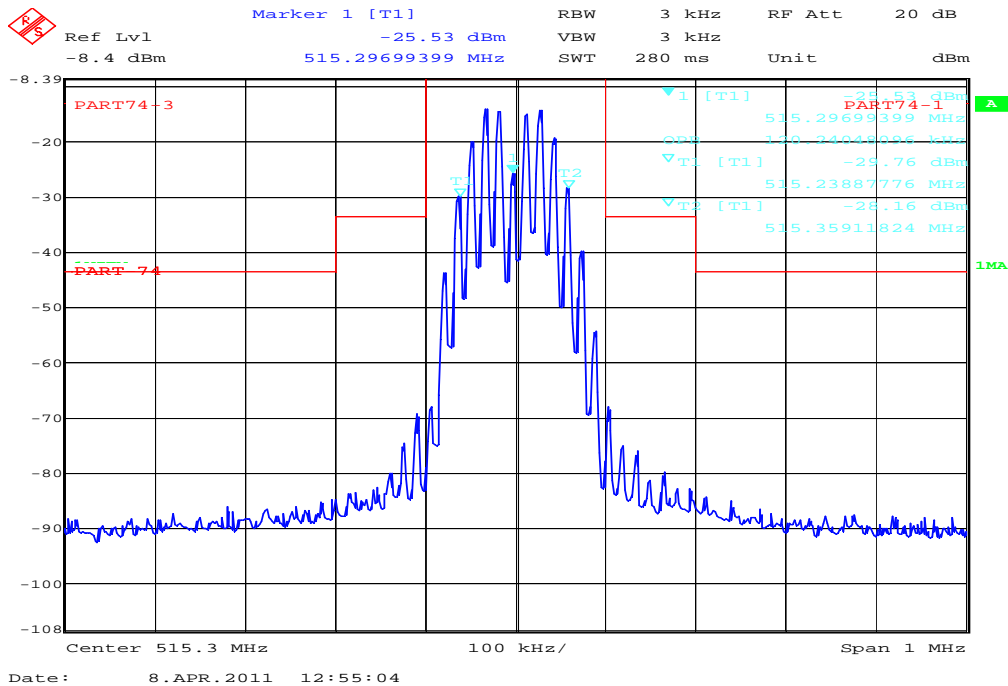

Plot 3: Band VII (500.1MHz-530.5MHz) high channel

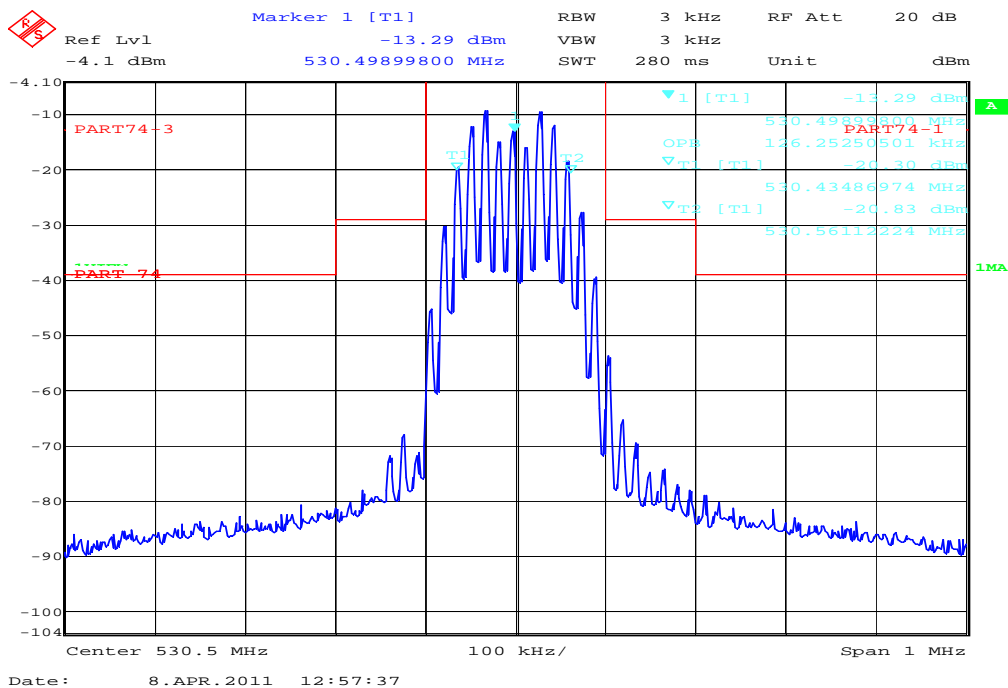

Plot 4: Band VIII (570.1MHz-600.5MHz) low channel

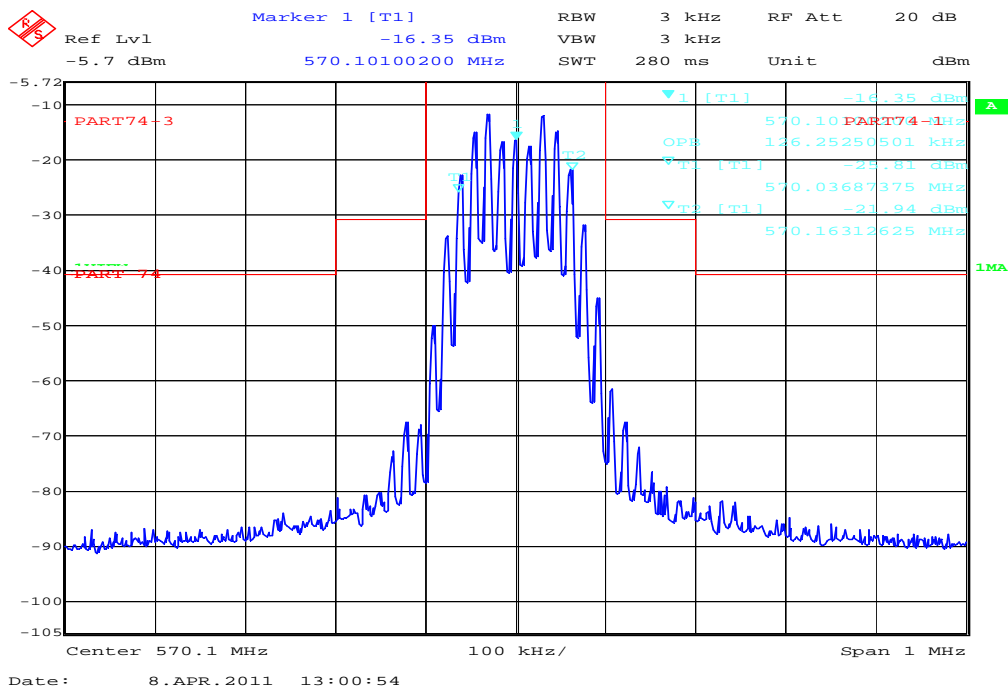

Plot 5: Band VIII (570.1MHz-600.5MHz) middle channel

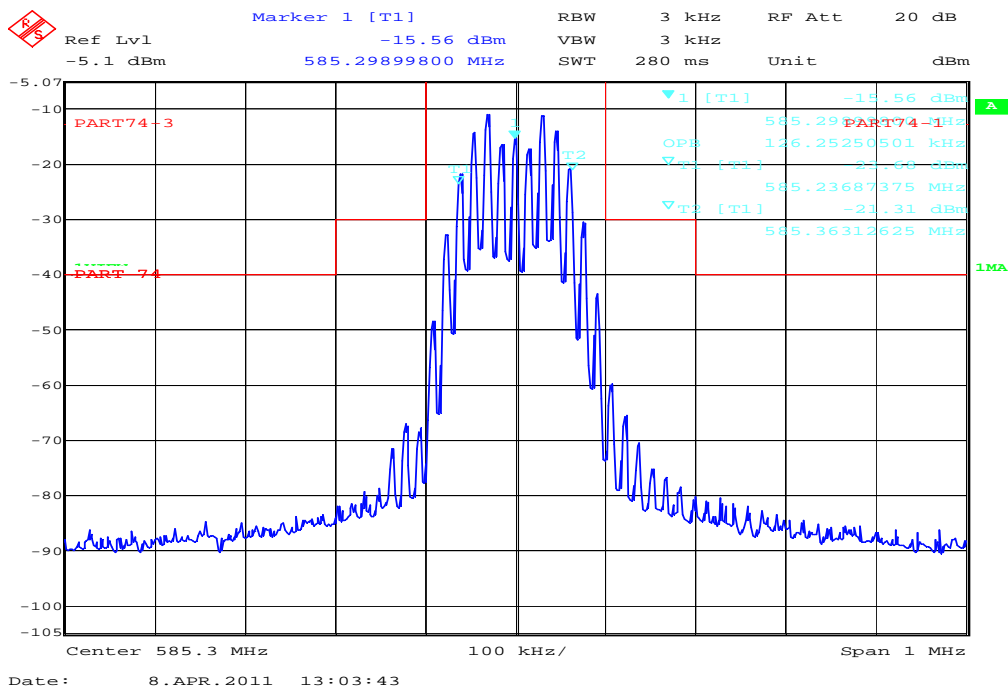

Plot 6: Band VIII (570.1MHz-600.5MHz) high channel

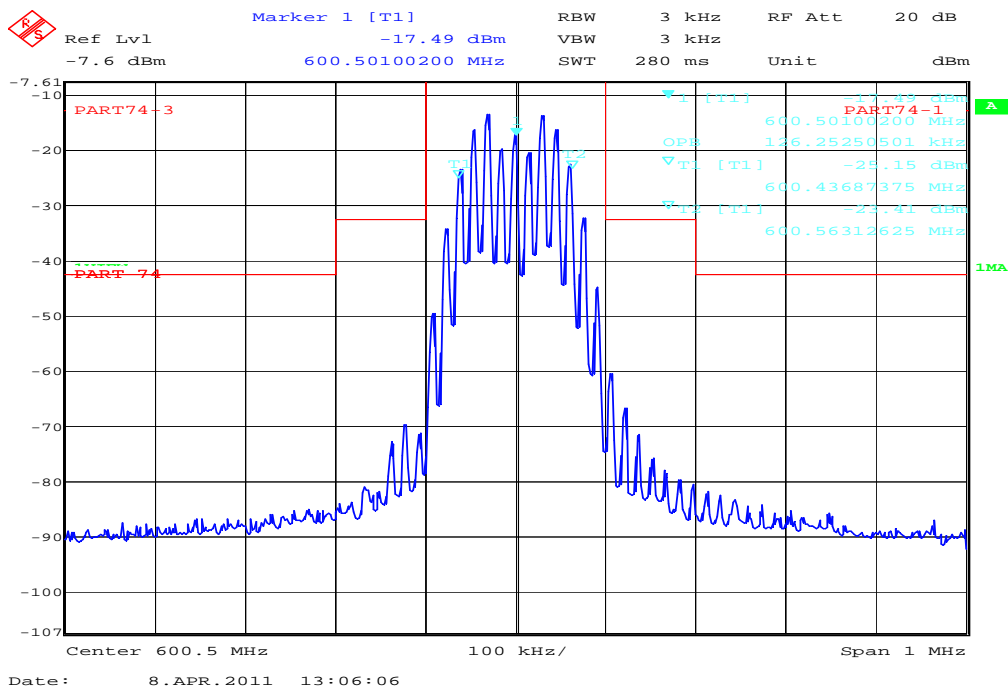

Plot 7: Band IX (600.0MHz-605.9MHz) low channel

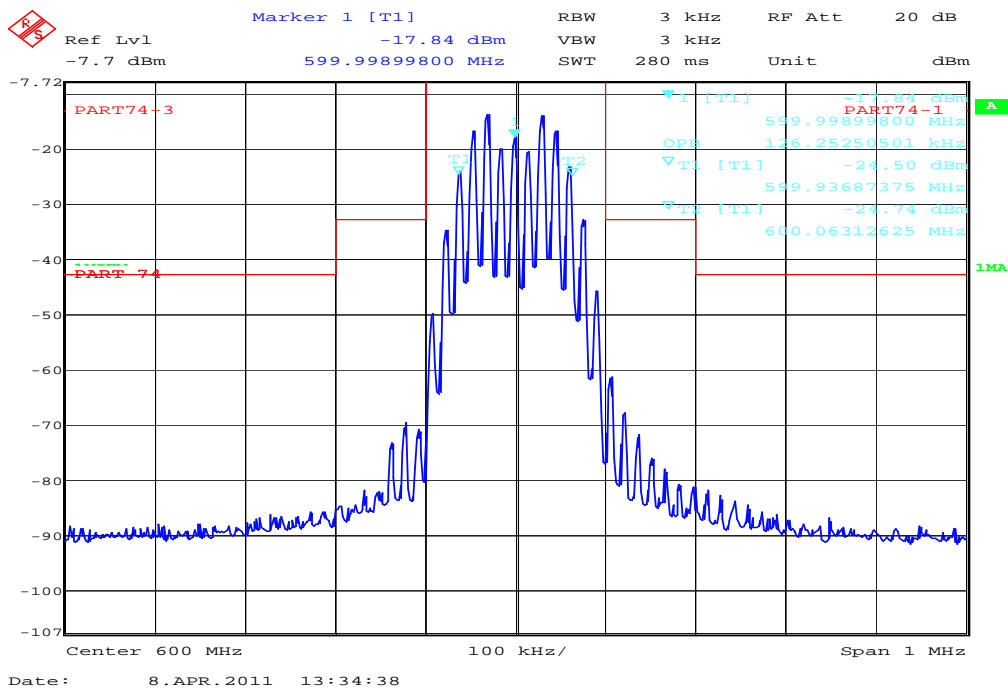

Plot 8: Band IX (600.0MHz-605.9MHz) high channel

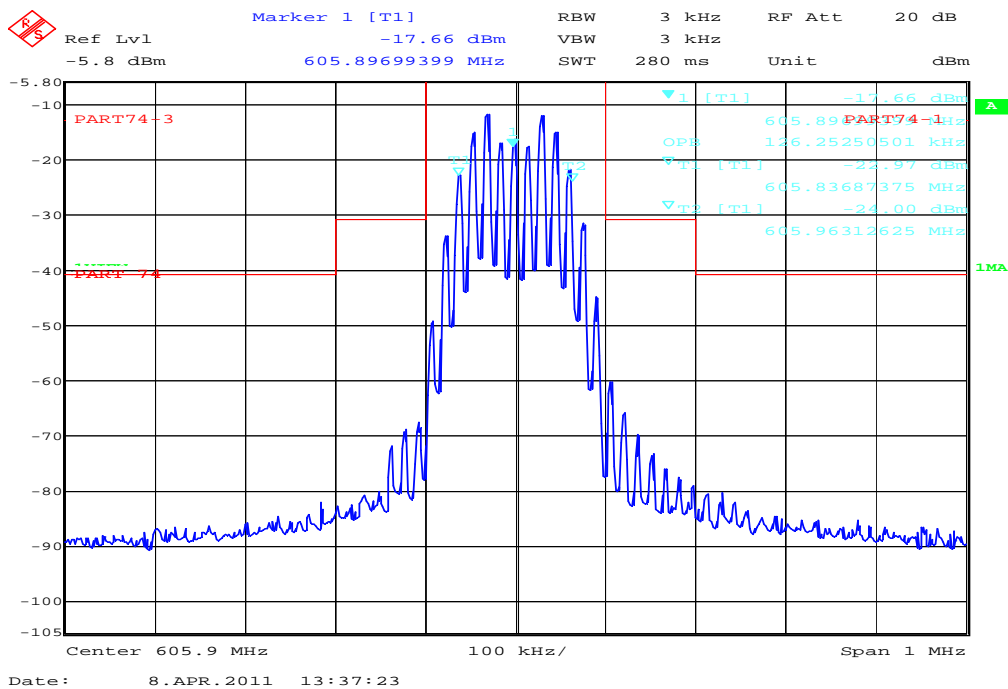

Plot 9: Band IX (614.1MHz-630.5MHz) low channel

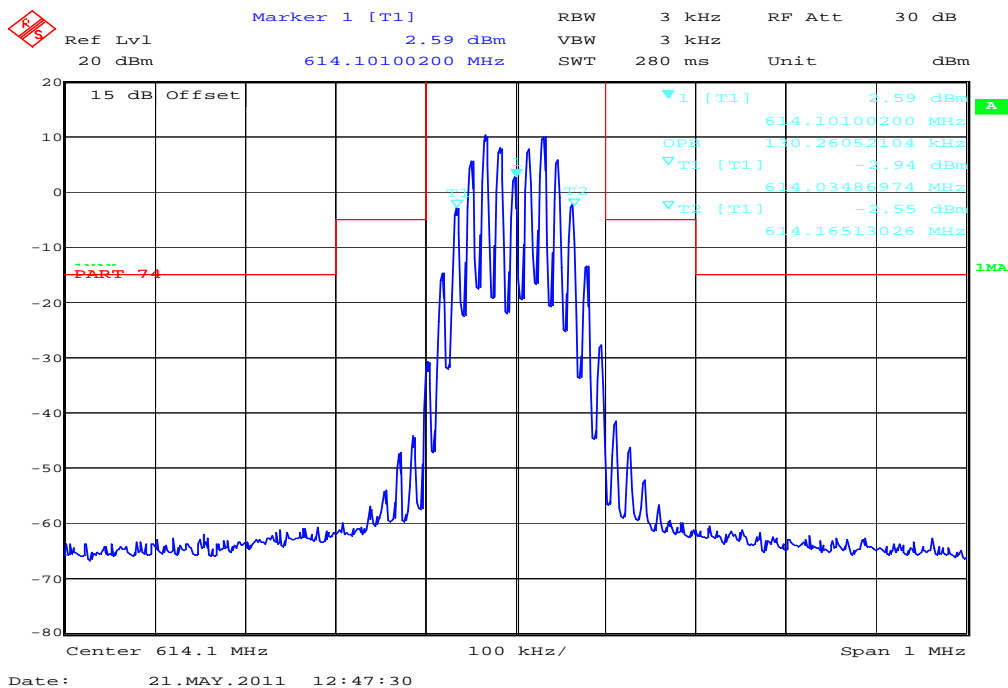

Plot 10: Band IX (614.0MHz-630.5MHz) middle channel

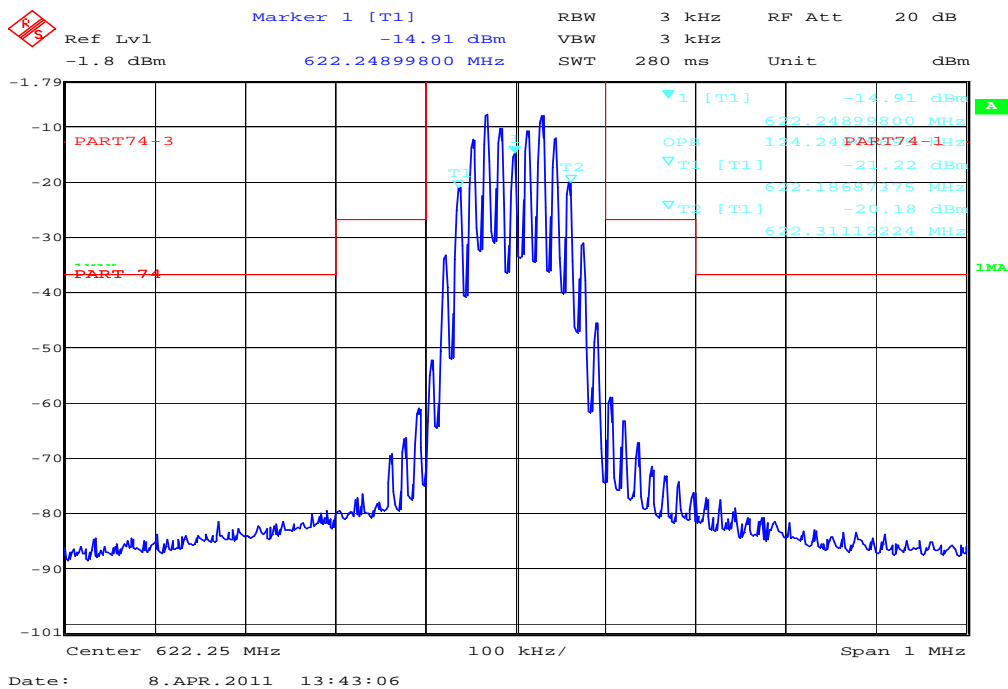



Plot 11: Band IX (614.0MHz-630.5MHz) high channel

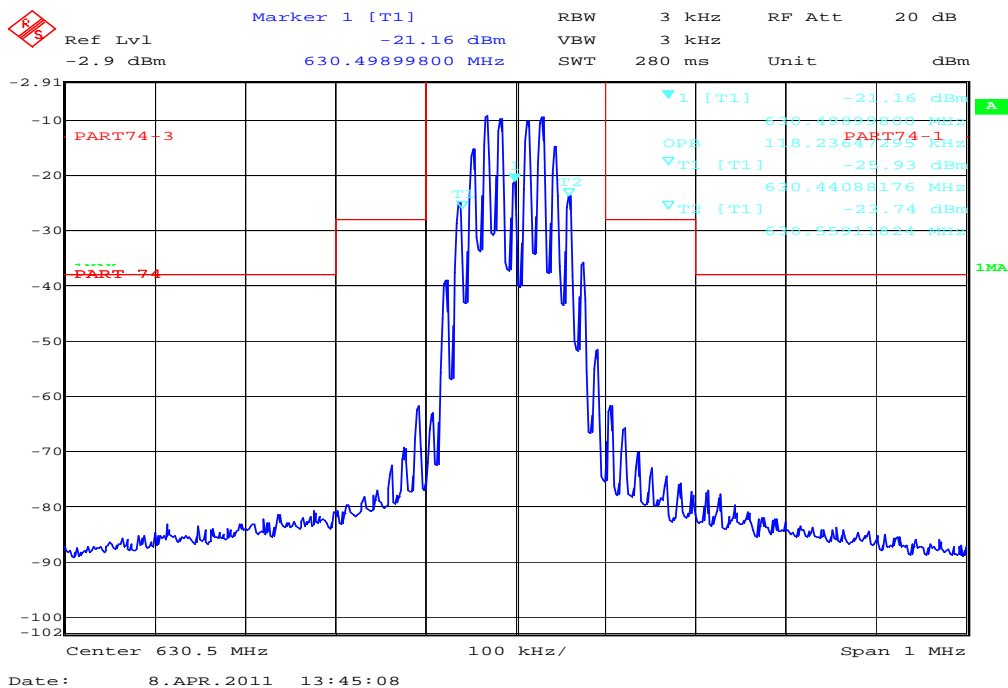

Plot 12: Band I (650.1MHz-680.0MHz) low channel

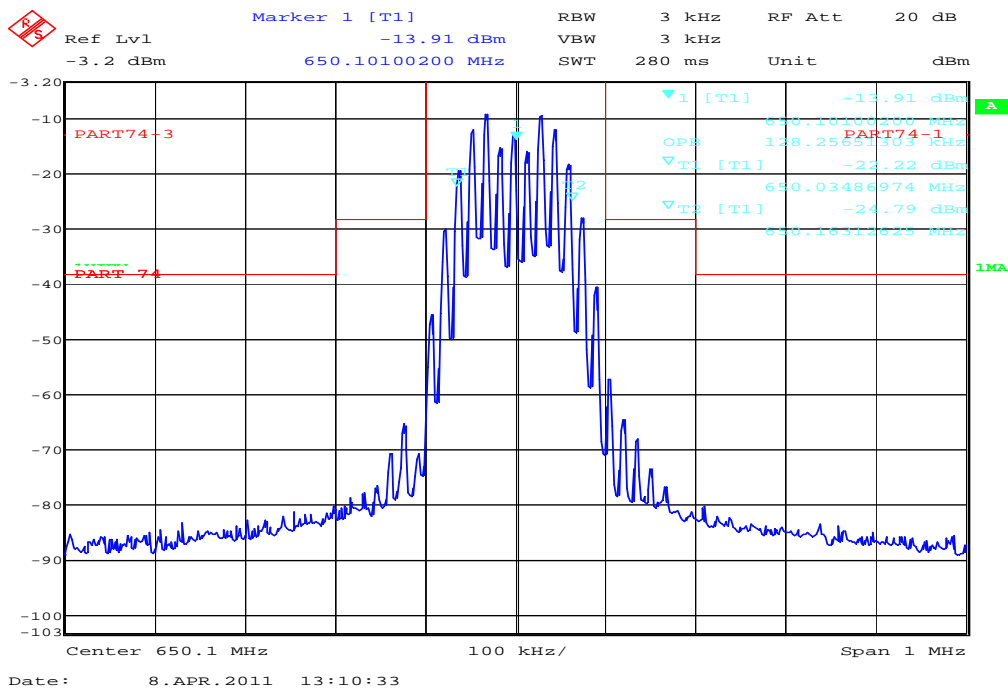

Plot 13: Band I (650.1MHz-680.0MHz) middle channel

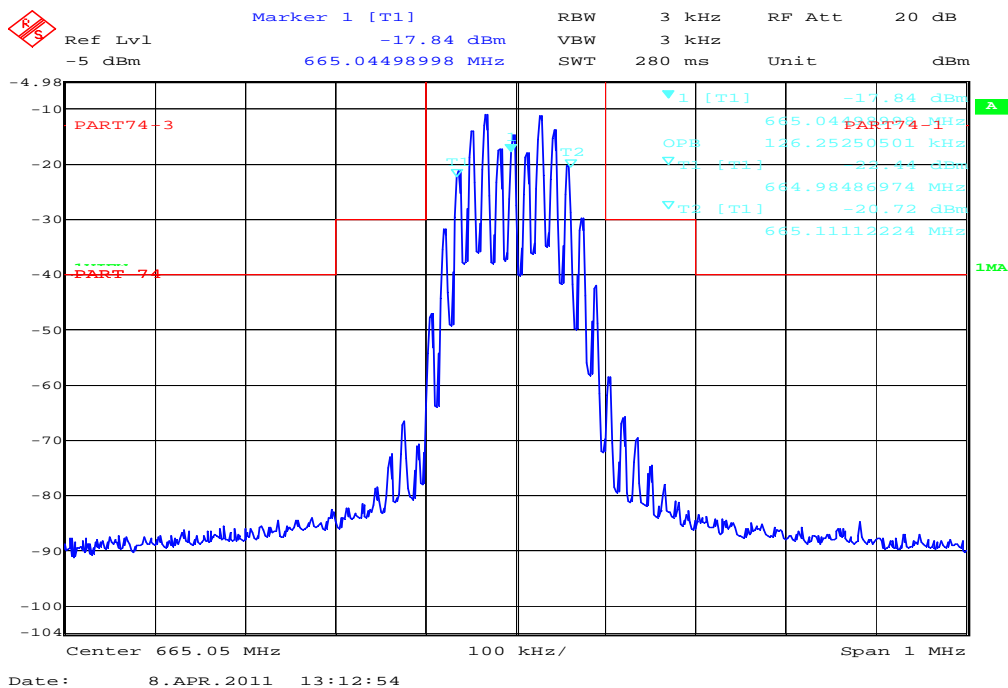

Plot 14: Band I (650.1MHz-680.0MHz) high channel

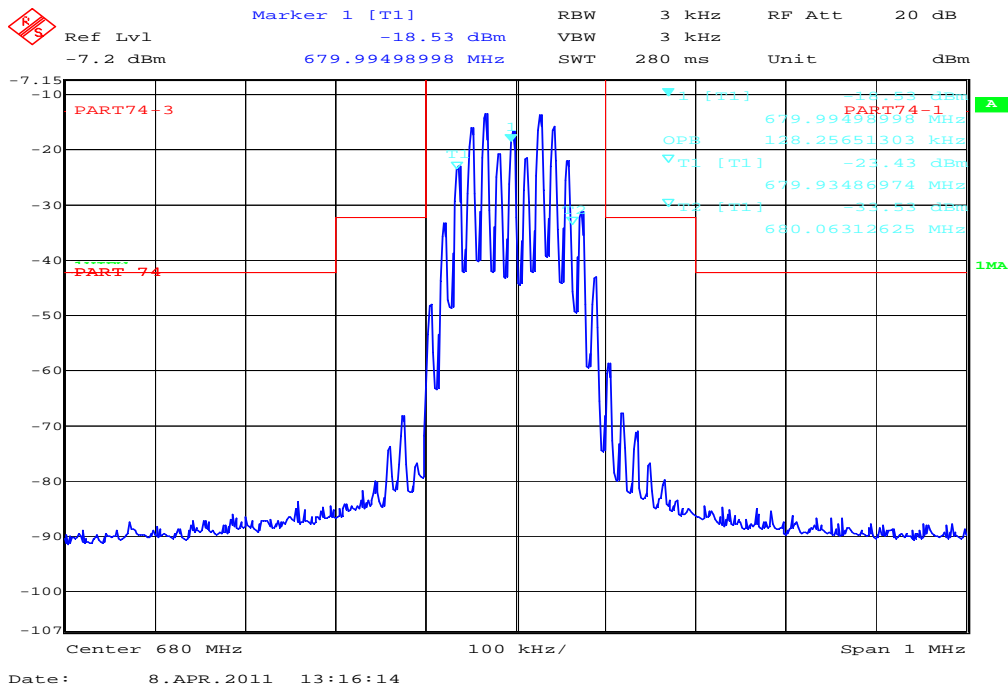

## 9.5 Unwanted radiation (spectrum mask)

### Measurement:

| Measurement parameter |           |
|-----------------------|-----------|
| Detector:             | Peak      |
| Sweep time:           | Auto      |
| Resolution bandwidth: | 3kHz      |
| Video bandwidth:      | 3kHz      |
| Span:                 | 1MHz      |
| Trace-Mode:           | Max. hold |

### Limits:

| FCC  | IC                   |
|--|----------------------|
| 47 CFR § 74.861  | RSS-123 §5.5 Issue 2 |
| <p>The mean power of emissions shall be attenuated below the mean output power of the transmitter in accordance with the following schedule:</p> <ul style="list-style-type: none"> <li>(i) On any frequency removed from the operating frequency by more than 50 percent up to and including 100 percent of the authorized bandwidth: at least 25 dB;</li> <li>(ii) On any frequency removed from the operating frequency by more than 100 percent up to and including 250 percent of the authorized bandwidth: at least 35 dB;</li> <li>(iii) On any frequency removed from the operating frequency by more than 250 percent of the authorized bandwidth: at least <math>43+10\log_{10}</math> (mean output power in watts) dB.</li> </ul> |                      |

**Result: The result of the measurement is passed.**

Plots of the measurements

Plot 1: Band VII (500.1MHz-530.5MHz) low channel

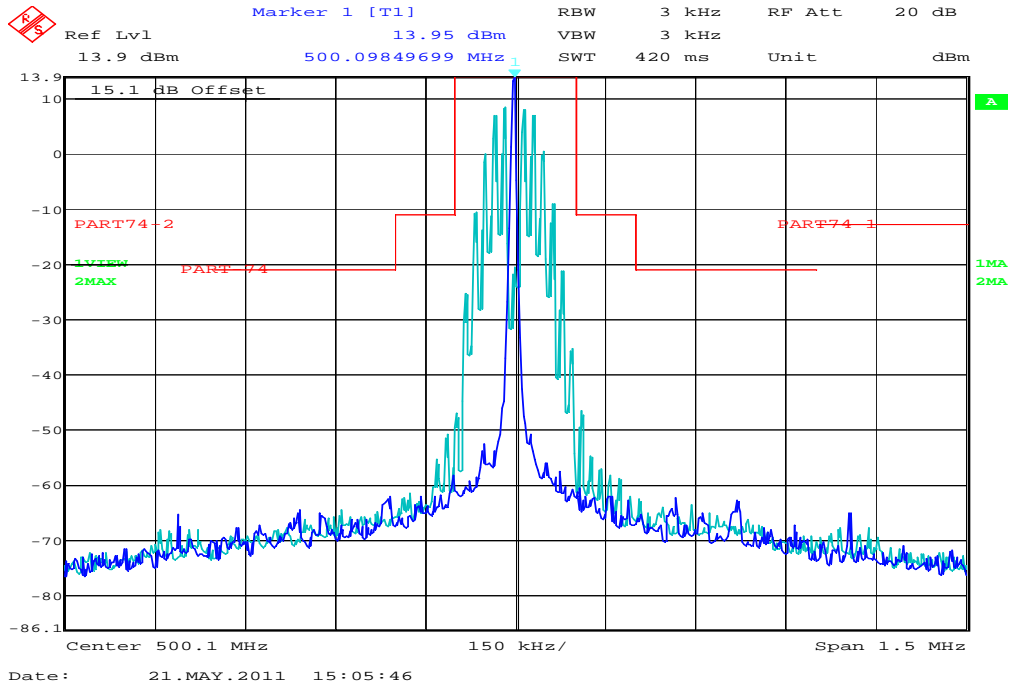

Plot 2: Band VII (500.1MHz-530.5MHz) middle channel

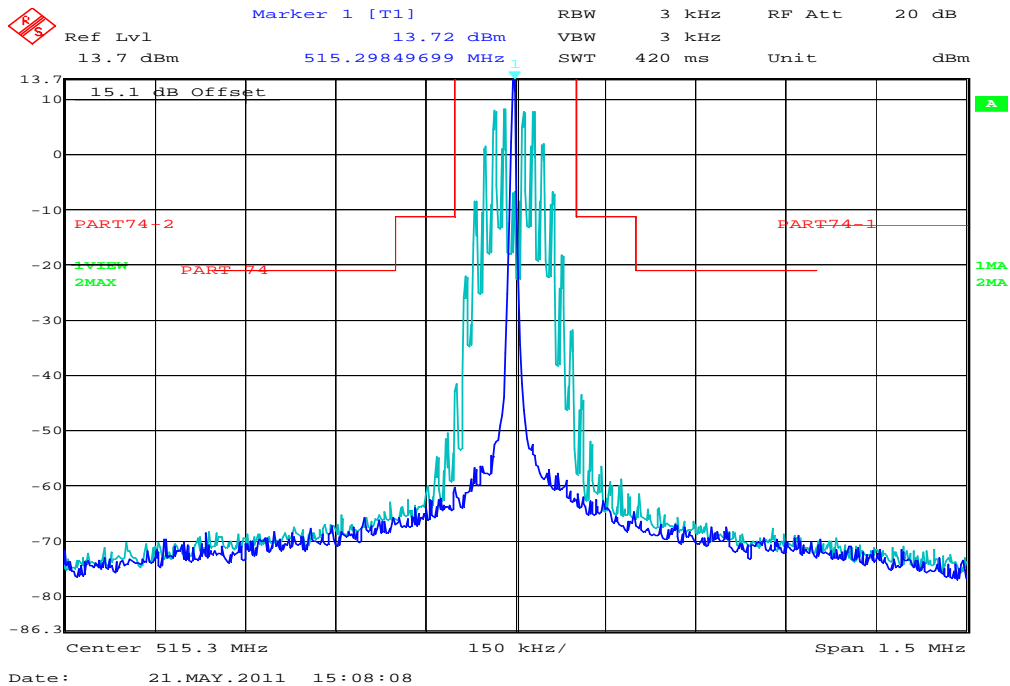

Plot 3: Band VII (500.1MHz-530.5MHz) high channel

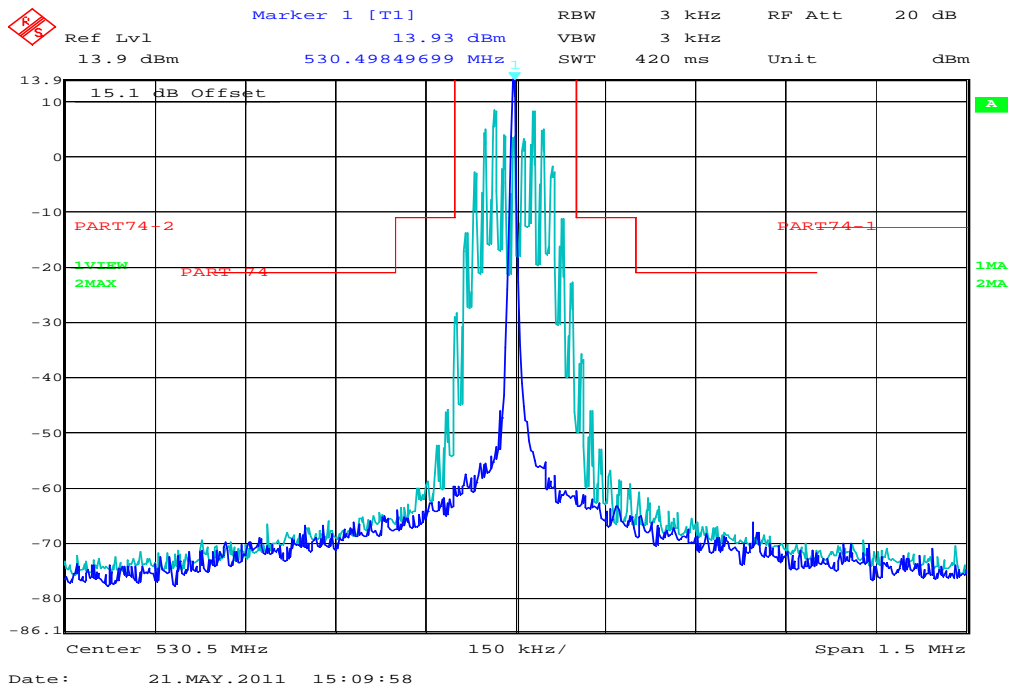

Plot 4: Band VIII (570.1MHz-600.5MHz) low channel

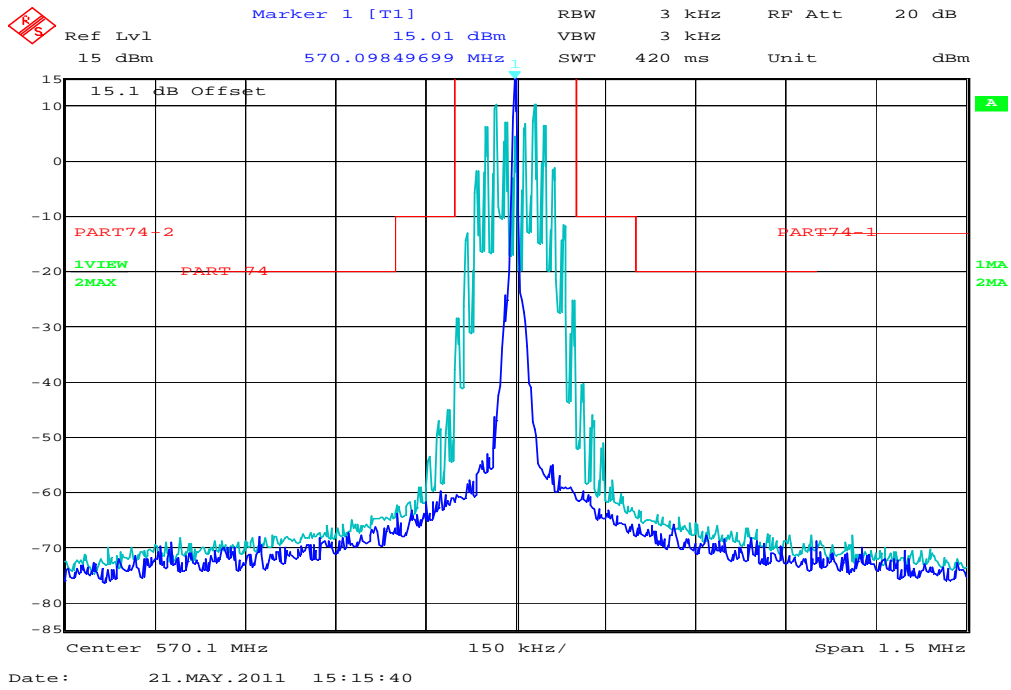

Plot 5: Band VIII (570.1MHz-600.5MHz) middle channel

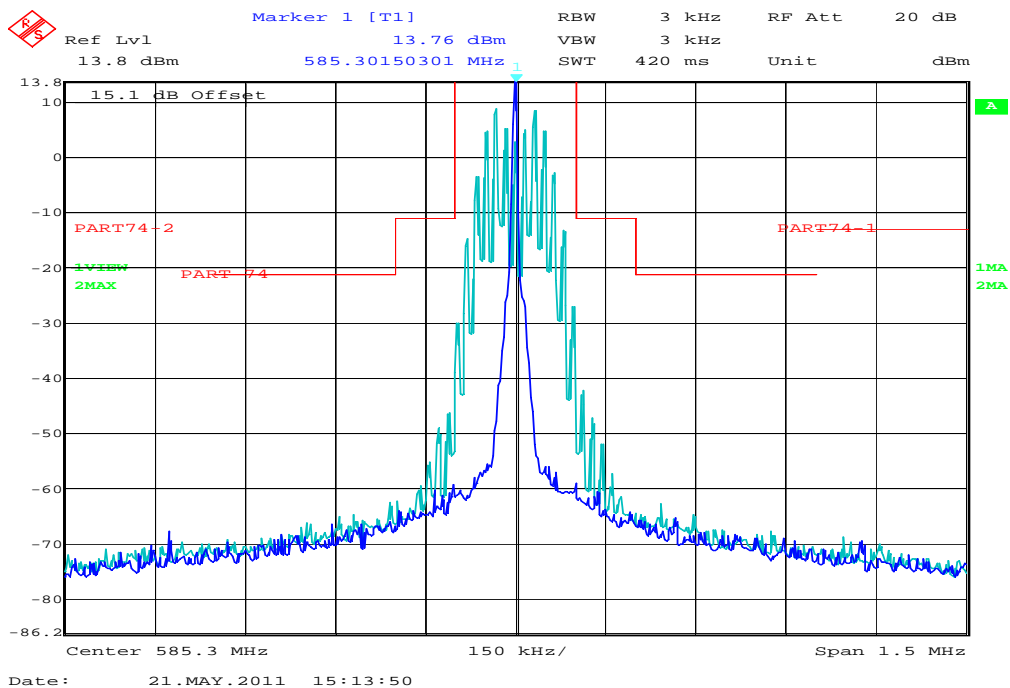

Plot 6: Band VIII (570.1MHz-600.5MHz) high channel

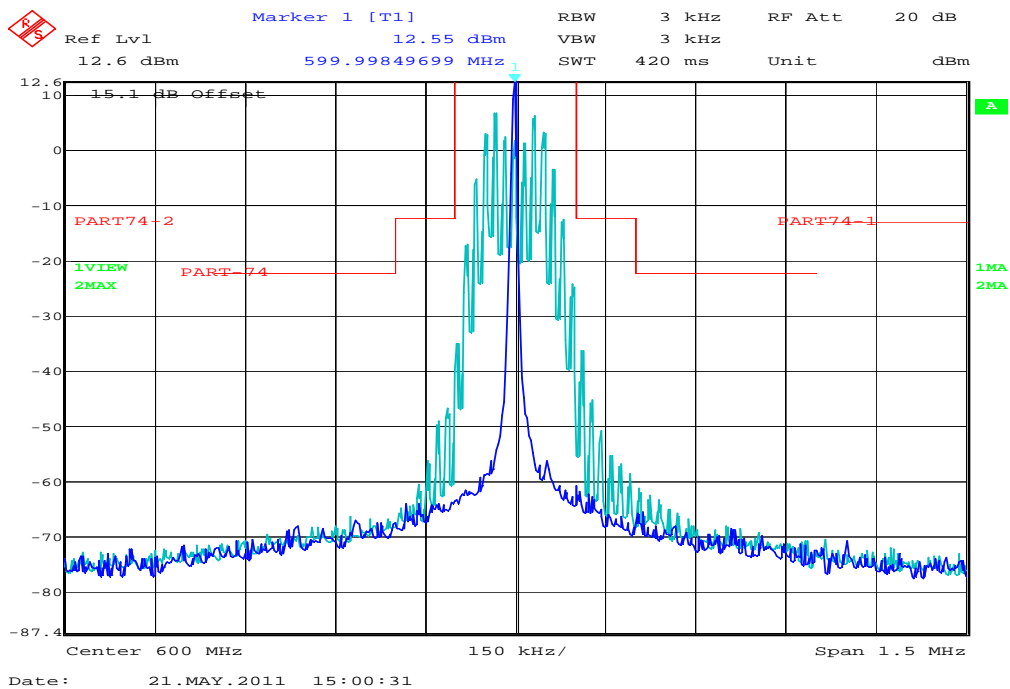

Plot 7: Band IX (600.0MHz-605.9MHz) low channel

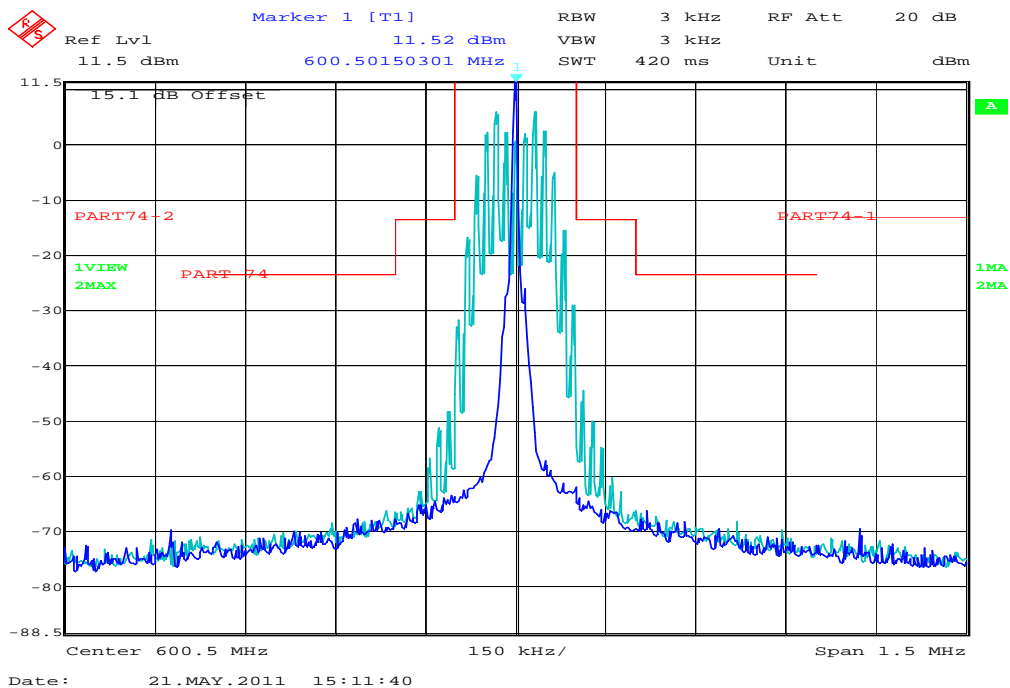

Plot 8: Band IX (600.0MHz-605.9MHz) high channel

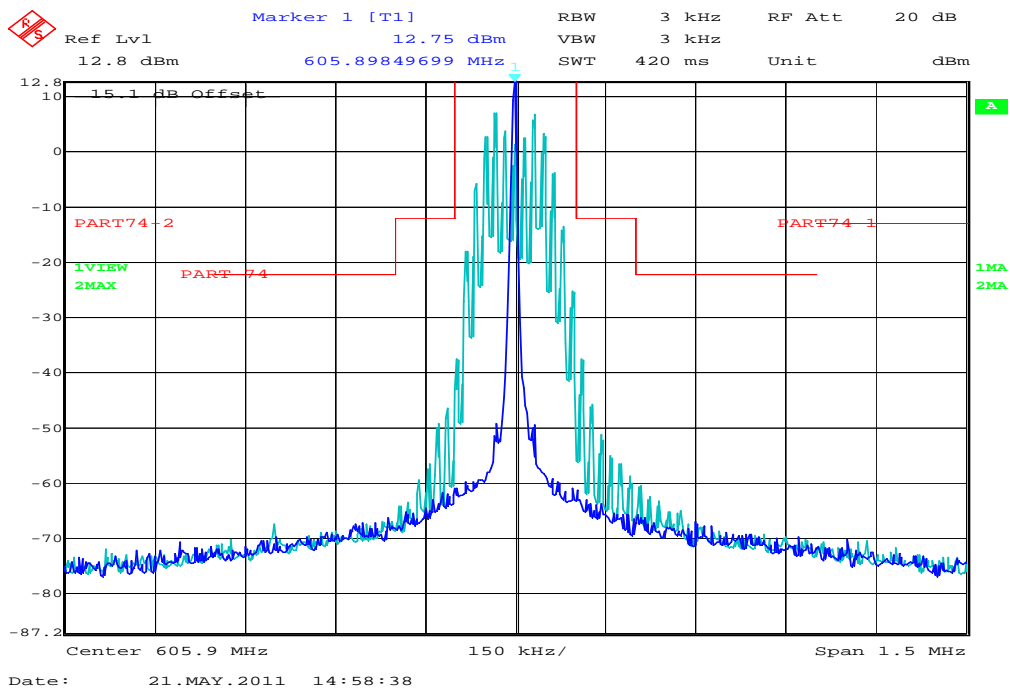

Plot 9: Band IX (614.1MHz-630.5MHz) low channel

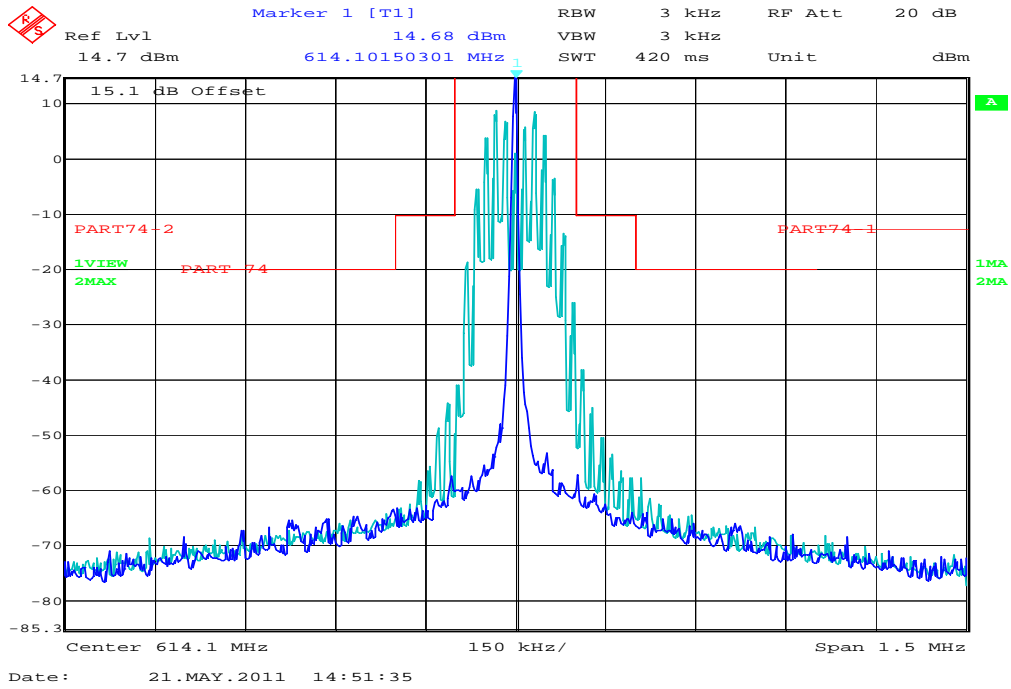

Plot 10: Band IX (614.1MHz-630.5MHz) middle channel

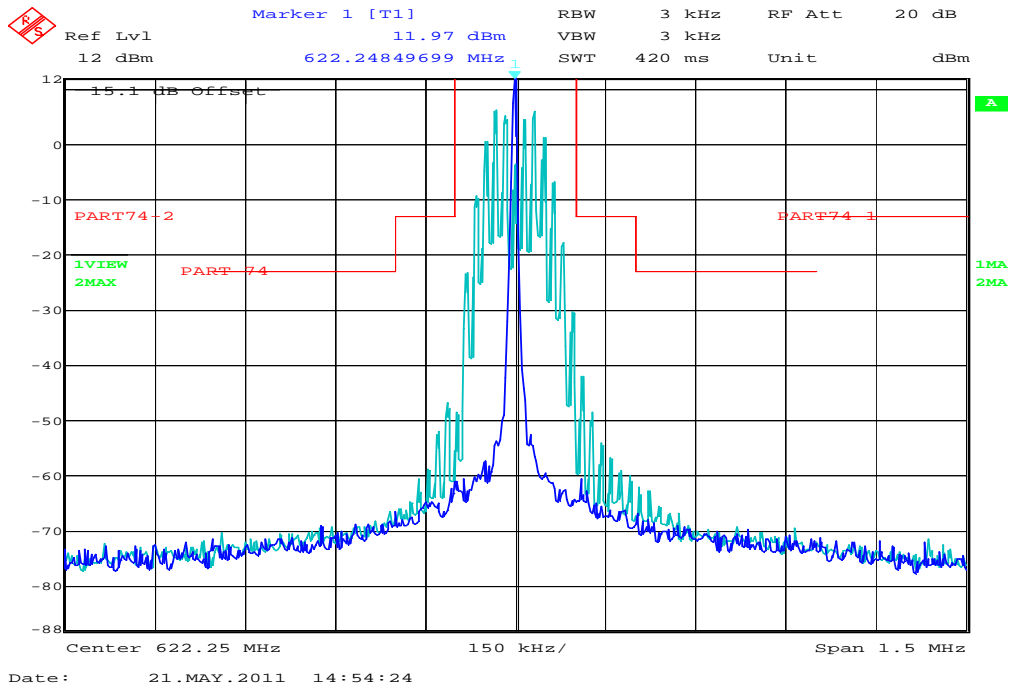



Plot 11: Band IX (614.1MHz-630.5MHz) high channel

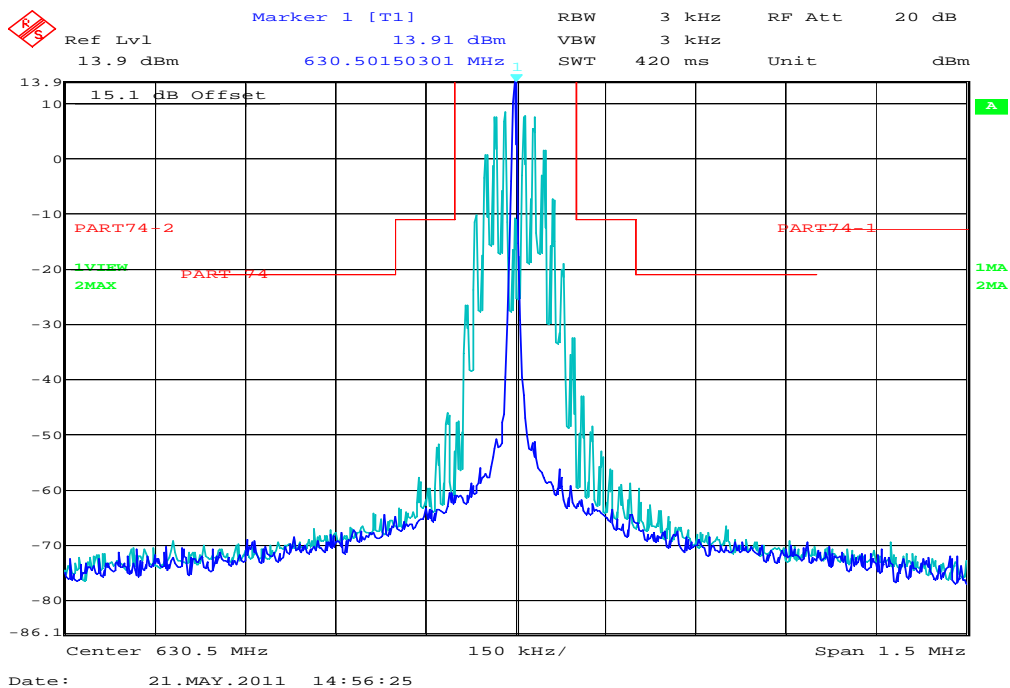

Plot 12: Band I (650.1MHz-680.0MHz) low channel

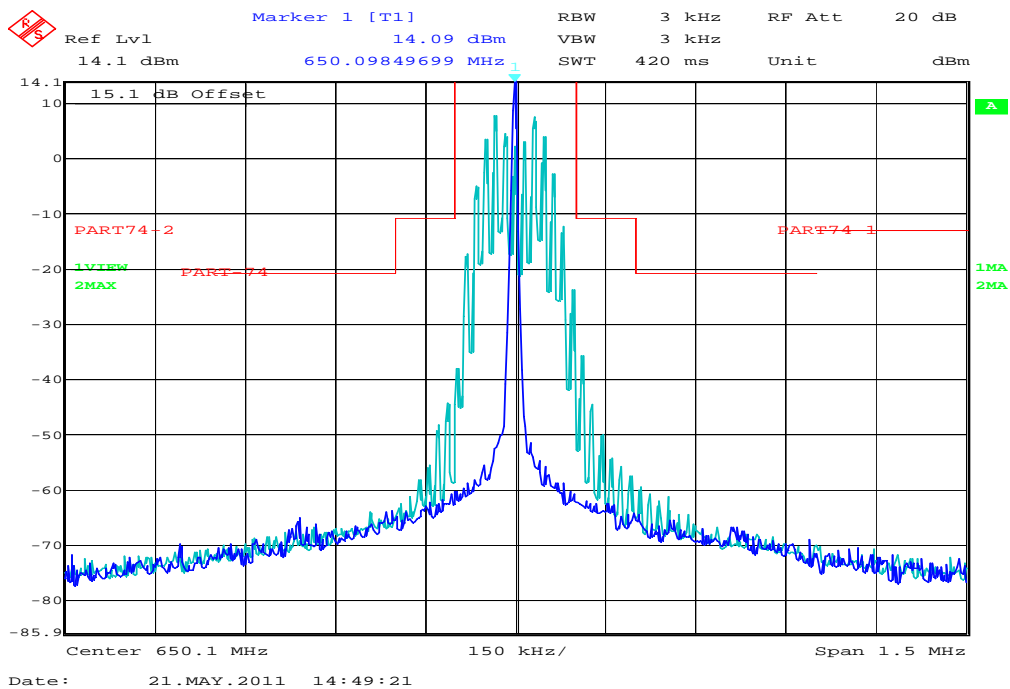

Plot 13: Band I (650.1MHz-680.0MHz) middle channel

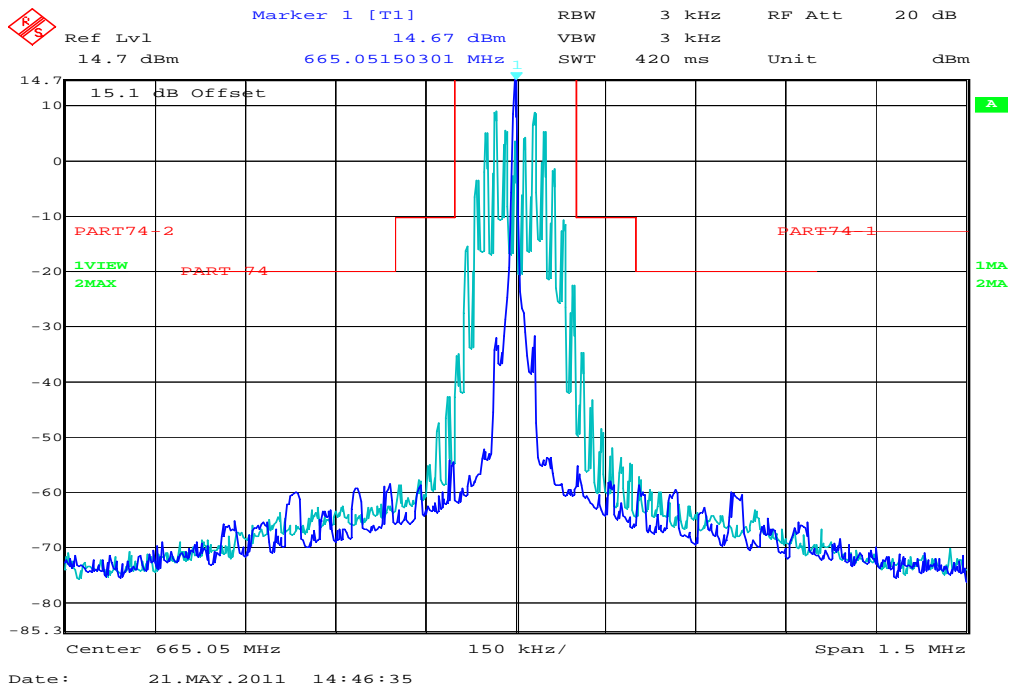

Plot 14: Band I (650.1MHz-680.0MHz) high channel

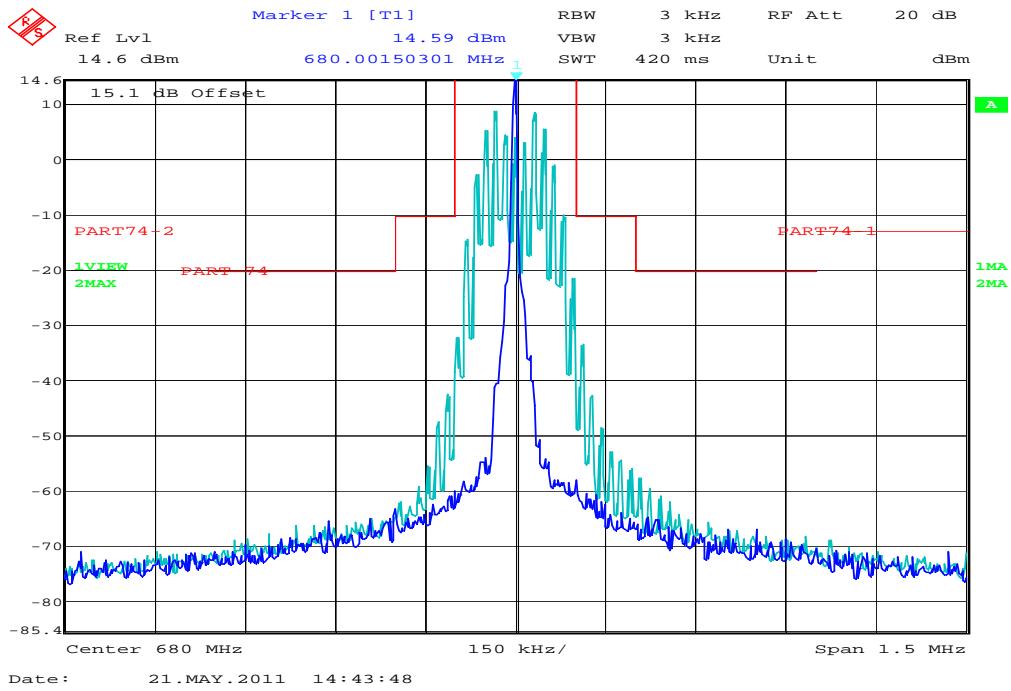

**9.6 Field strength of spurious radiation.**

**Measurement:**

| Measurement parameter |   |
|-----------------------|---|
| Detector:             | Peak                                    |
| Sweep time:           | Auto                                    |
| Resolution bandwidth: | f < 1 GHz : 100 kHz<br>f ≥ 1GHz : 1 MHz |
| Video bandwidth:      | f < 1 GHz : 100 kHz<br>f ≥ 1GHz : 1 MHz |
| Span:                 | -/-                                     |
| Trace-Mode:           | Max. hold                               |

**Limits:**

| FCC  | IC |
|--|----|
| <p>Emissions for LPRS transmitters operating on standard band channels (25 kHz) shall be attenuated below the unmodulated carrier in accordance with the following:<br/>                     Emissions 12.5 kHz to 22.5 kHz away from the channel center frequency: at least 30 dB; and emissions more than 22.5 kHz away from the channel center frequency:<br/> <b>FCC:</b> at least 43 + 10log(carrier power in watts) dB<br/> <b>IC:</b> at least 55 + 10log(carrier power in watts) dB.</p> |    |

**Result:**

Band VII (500.1MHz-530.5MHz):

| SPURIOUS EMISSIONS LEVEL (dBm)                                   |          |       |  |          |       |                 |          |       |
|--|----------|-------|--|----------|-------|-----------------|----------|-------|
| Lowest channel   |          |       | Middle channel   |          |       | Highest channel |          |       |
| Frequency  | Detector | Level | Frequency  | Detector | Level | Frequency       | Detector | Level |
| All detected peaks are more than 20dB below the spurious limit * |          |       | All detected peaks are more than 20dB below the spurious limit * |          |       |                 |          |       |
| 3500.7   | PK       | -36.5 | 3607.1   | PK       | -35.7 | 3713.5          | PK       | -33.9 |
| 4000.8   | PK       | -34.4 | 6183.5   | PK       | -37.2 | 4774.5          | PK       | -38.4 |
| 5501.1   | PK       | -35.2 | 6698.9   | PK       | -37.5 | 5304.9          | PK       | -39.4 |
|  |          |       |  |          |       | 6366.0          | PK       | -32.2 |
|  |          |       |  |          |       | 6896.5          | PK       | -37.1 |
| Measurement uncertainty<br>± 3 dB                                |          |       |  |          |       |                 |          |       |

\* highest peaks stated

Band VIII (570.1MHz-600.5MHz):

| SPURIOUS EMISSIONS LEVEL (dBm)    |          |       |                |          |       |  |          |       |
|-----------------------------------|----------|-------|----------------|----------|-------|--|----------|-------|
| Lowest channel                    |          |       | Middle channel |          |       | Highest channel  |          |       |
| Frequency                         | Detector | Level | Frequency      | Detector | Level | Frequency  | Detector | Level |
|                                   |          |       |                |          |       | All detected peaks are more than 20dB below the spurious limit * |          |       |
| 3990.8                            | PK       | -31.3 | 1170.5         | PK       | -38.5 | 4203.5   | PK       | -33.6 |
| 4560.7                            | PK       | -40.4 | 4097.1         | PK       | -32.4 | 4803.9   | PK       | -33.6 |
| 5701.0                            | PK       | -32.9 | 6438.3         | PK       | -37.8 | 6005.7   | PK       | -37.8 |
| 6841.2                            | PK       | -39.0 |                |          |       |  |          |       |
| 7411.3                            | PK       | -38.8 |                |          |       |  |          |       |
| Measurement uncertainty<br>± 3 dB |          |       |                |          |       |  |          |       |

\* highest peaks stated

Band IX (600.0MHz-605.9MHz):

| SPURIOUS EMISSIONS LEVEL (dBm)    |          |       |           |          |       |                 |          |       |
|-----------------------------------|----------|-------|-----------|----------|-------|-----------------|----------|-------|
| Lowest channel                    |          |       | -/-       |          |       | Highest channel |          |       |
| Frequency                         | Detector | Level | Frequency | Detector | Level | Frequency       | Detector | Level |
| 3600.0                            | PK       | -38.4 |           |          |       | 3635.3          | PK       | -38.1 |
| 4200.0                            | PK       | -31.7 |           |          |       | 4241.3          | PK       | -32.8 |
| 4800.0                            | PK       | -37.9 |           |          |       | 5453.0          | PK       | -35.3 |
| 5400.0                            | PK       | -35.5 |           |          |       | 6664.9          | PK       | -36.2 |
| 7200.0                            | PK       | -34.4 |           |          |       | 7270.0          | PK       | -35.6 |
| Measurement uncertainty<br>± 3 dB |          |       |           |          |       |                 |          |       |

Band IX (614.1MHz-630.5MHz):

| SPURIOUS EMISSIONS LEVEL (dBm)    |          |        |                |          |       |                 |          |       |
|-----------------------------------|----------|--------|----------------|----------|-------|-----------------|----------|-------|
| Lowest channel                    |          |        | Middle channel |          |       | Highest channel |          |       |
| Frequency                         | Detector | Level  | Frequency      | Detector | Level | Frequency       | Detector | Level |
| 4298.7                            | PK       | -32.00 | 3733.5         | PK       | -39.2 | 3783.0          | PK       | -27.4 |
| 4912.8                            | PK       | -38.00 | 4355.8         | PK       | -30.9 | 4413.5          | PK       | -26.7 |
| 6141.0                            | PK       | -35.60 | 5600.2         | PK       | -34.2 | 5044.1          | PK       | -35.8 |
| 6755.1                            | PK       | -37.70 | 6222.5         | PK       | -38.2 | 5674.6          | PK       | -29.5 |
| Measurement uncertainty<br>± 3 dB |          |        |                |          |       |                 |          |       |

Band I (650.1MHz-680.0MHz):

| SPURIOUS EMISSIONS LEVEL (dBm)    |          |       |                |          |       |                 |          |       |
|-----------------------------------|----------|-------|----------------|----------|-------|-----------------|----------|-------|
| Lowest channel                    |          |       | Middle channel |          |       | Highest channel |          |       |
| Frequency                         | Detector | Level | Frequency      | Detector | Level | Frequency       | Detector | Level |
| 1300.2                            | PK       | -43.4 | 1330.0         | PK       | -44.1 | 2040.0          | PK       | -34.4 |
| 1950.3                            | PK       | -34.4 | 1995.0         | PK       | -32.0 | 4079.9          | PK       | -36.4 |
| 3900.6                            | PK       | -30.8 | 3990.2         | PK       | -30.7 | 4760.8          | PK       | -32.8 |
| 5201.0                            | PK       | -40.3 | 4655.1         | PK       | -35.4 | 5440.0          | PK       | -42.0 |
| 5850.9                            | PK       | -35.8 | 5985.1         | PK       | -37.6 | 6120.0          | PK       | -36.3 |
| Measurement uncertainty<br>± 3 dB |          |       |                |          |       |                 |          |       |

**Result:** The result of the measurement is passed.

**Plots of the measurements:**

Plot 1: Band VII (500.1MHz-530.5MHz) low channel, <30MHz

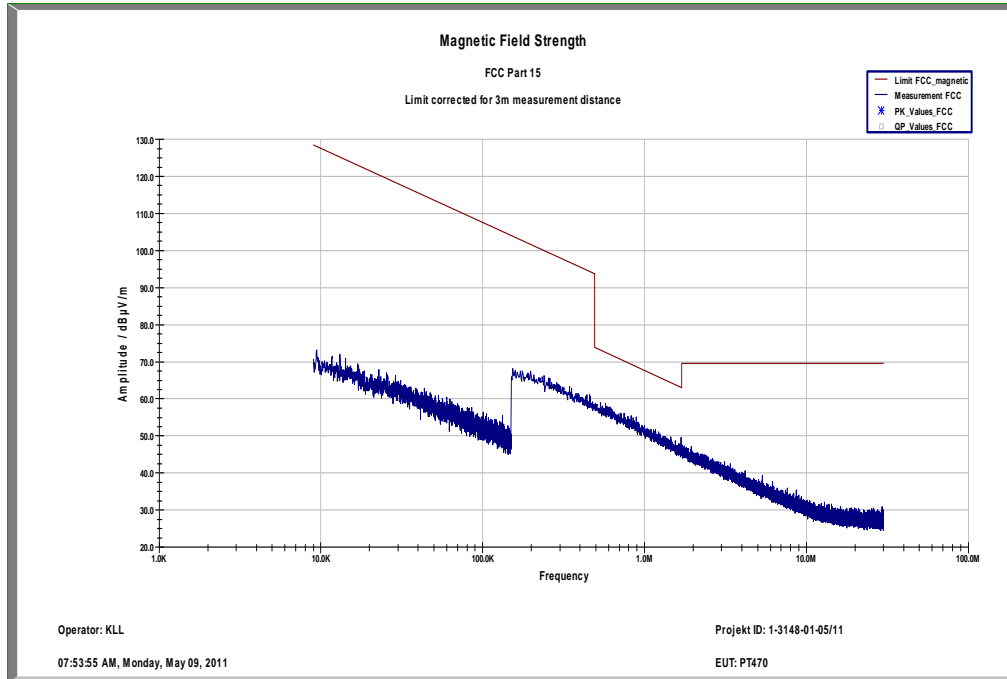

Plot 2: Band VII (500.1MHz-530.5MHz) low channel, 30 MHz – 1 GHz, antenna vertical

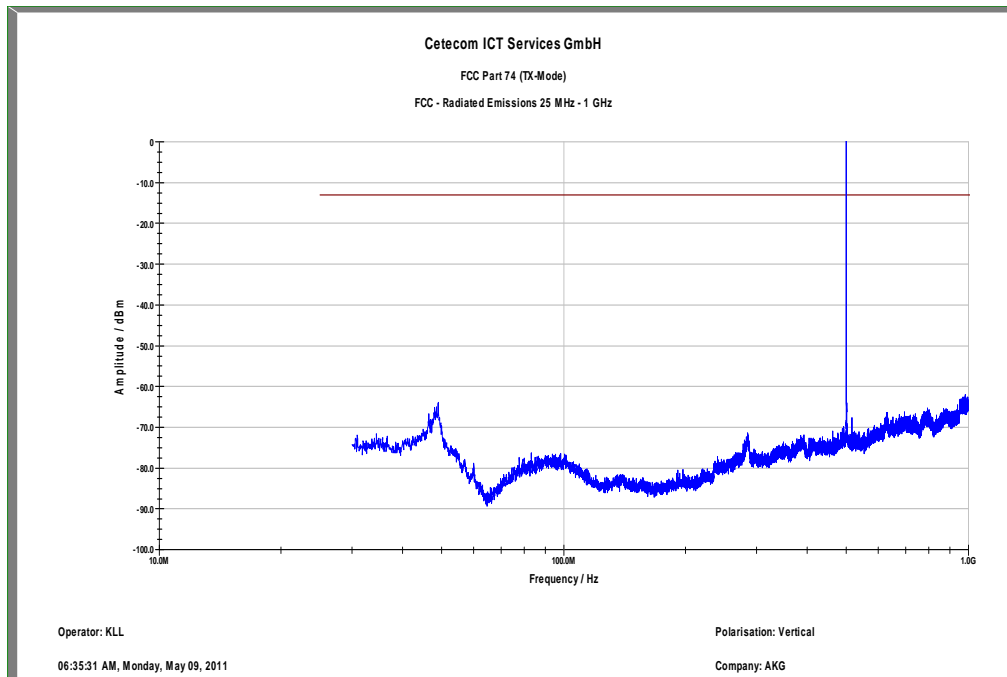

Plot 3: Band VII (500.1MHz-530.5MHz) low channel, 1 GHz – 12.75 GHz, antenna vertical

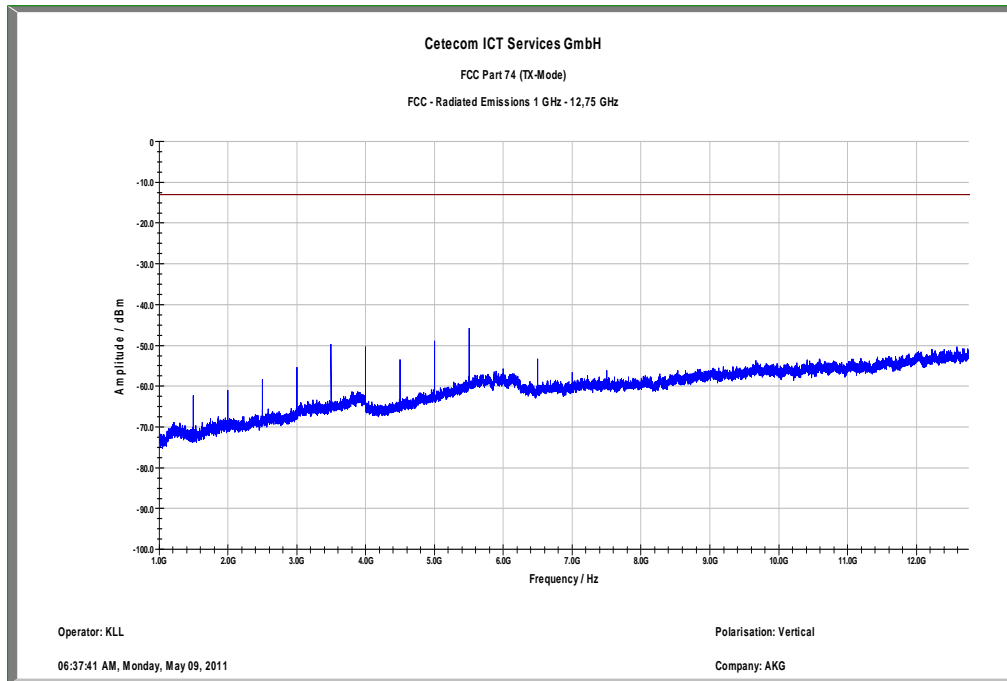

Plot 4: Band VII (500.1MHz-530.5MHz) low channel, 30 MHz – 1 GHz, antenna horizontal

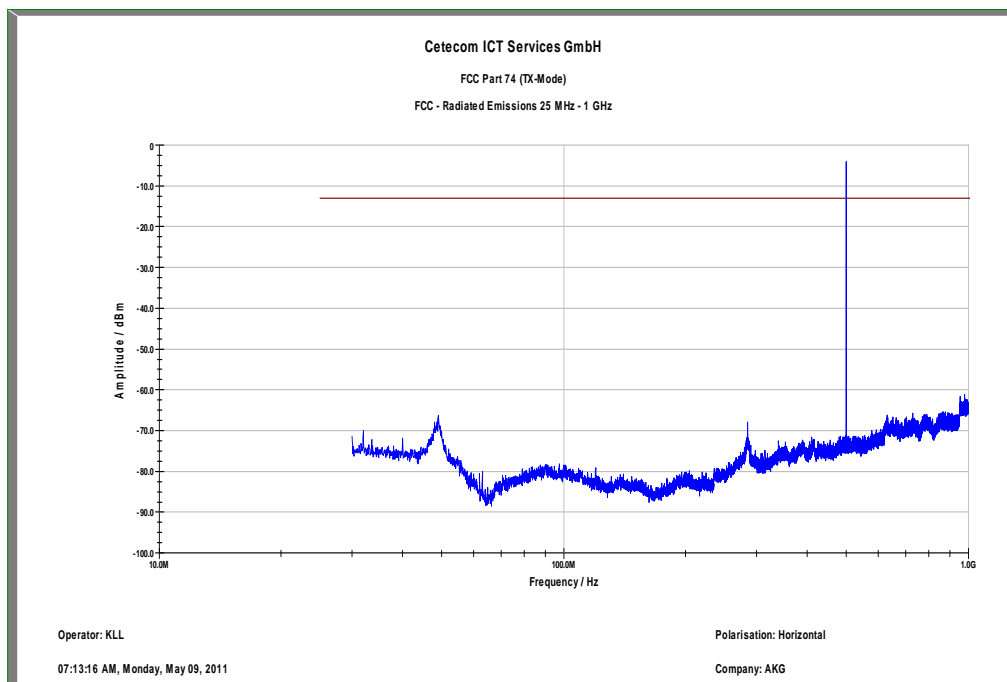

Plot 5: Band VII (500.1MHz-530.5MHz) low channel, 1 GHz – 12.75 GHz, antenna horizontal

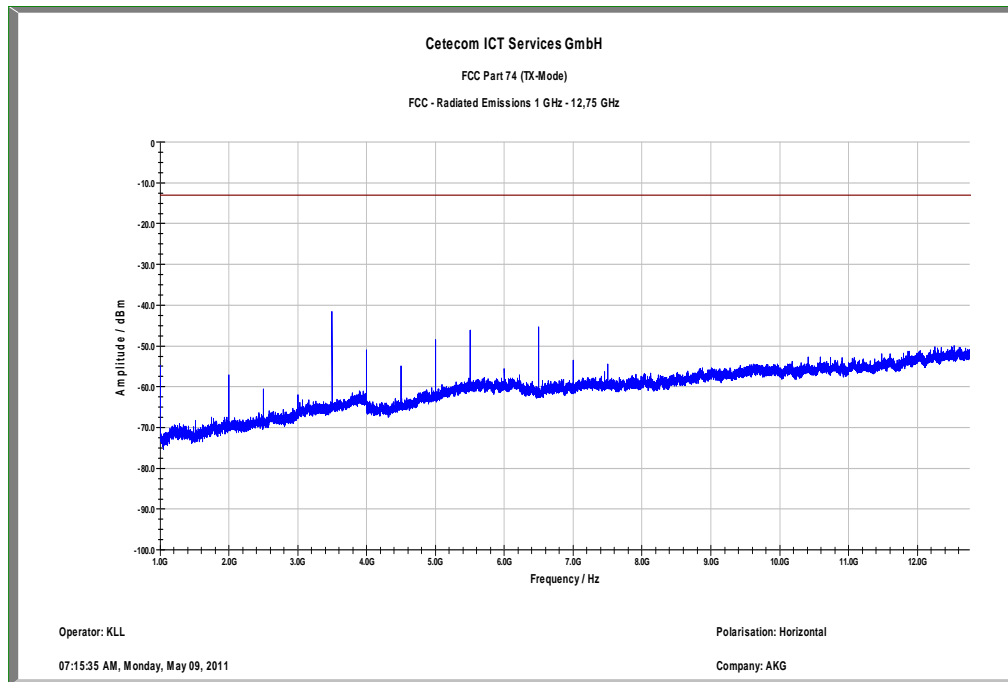

Plot 6: Band VII (500.1MHz-530.5MHz) middle channel, <30MHz

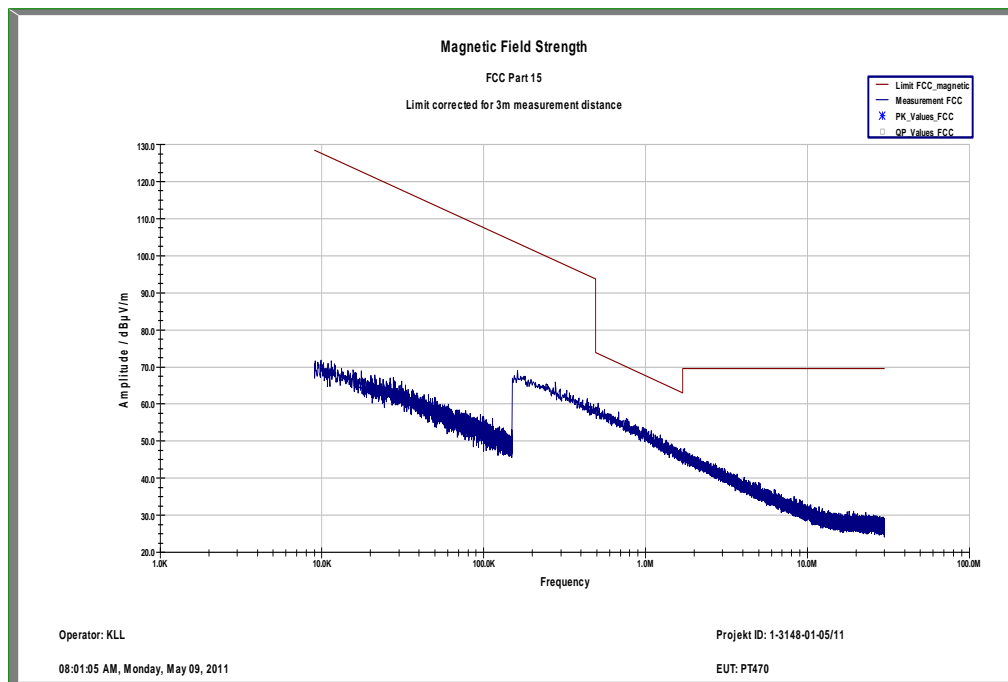



Plot 7: Band VII (500.1MHz-530.5MHz) middle channel, 30 MHz – 1 GHz, antenna vertical

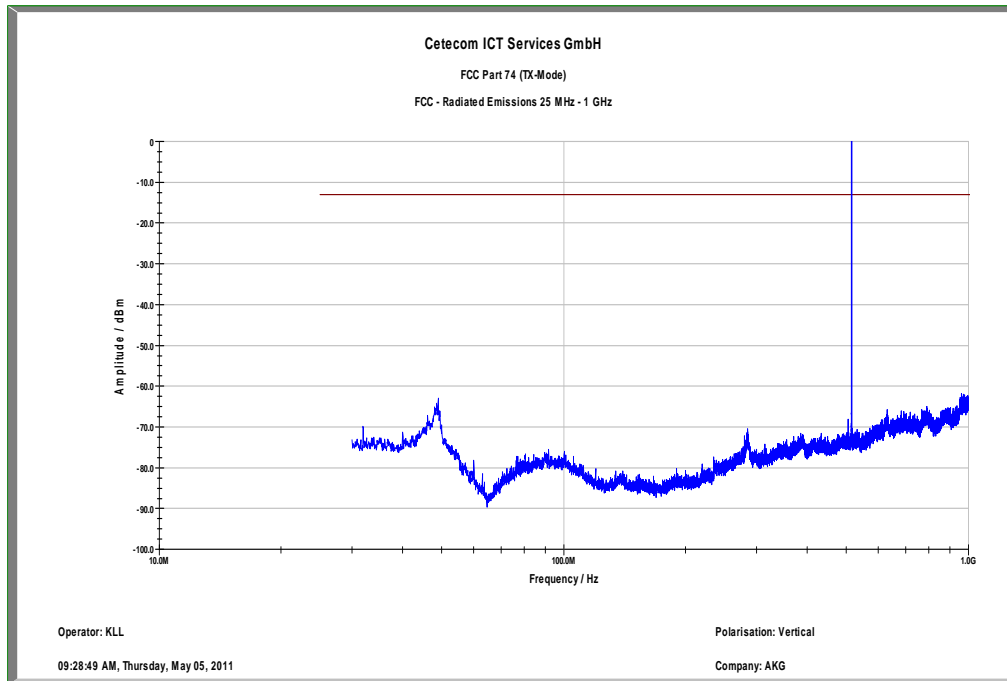

Plot 8: Band VII (500.1MHz-530.5MHz) middle channel, 1 GHz – 12.75 GHz, antenna vertical

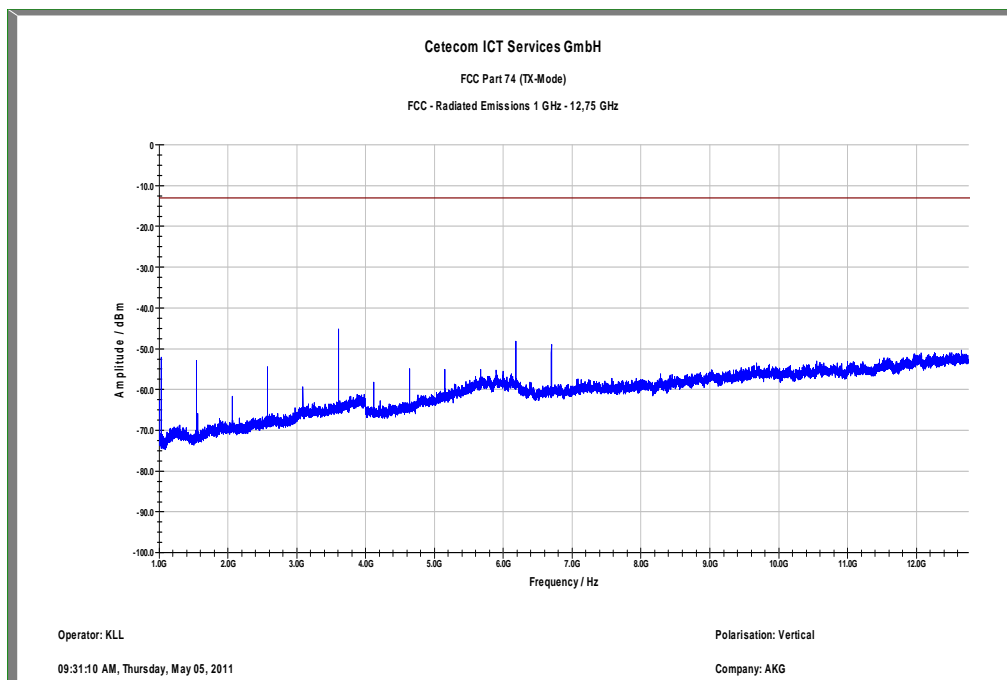

Plot 9: Band VII (500.1MHz-530.5MHz) middle channel, 30 MHz – 1 GHz, antenna horizontal

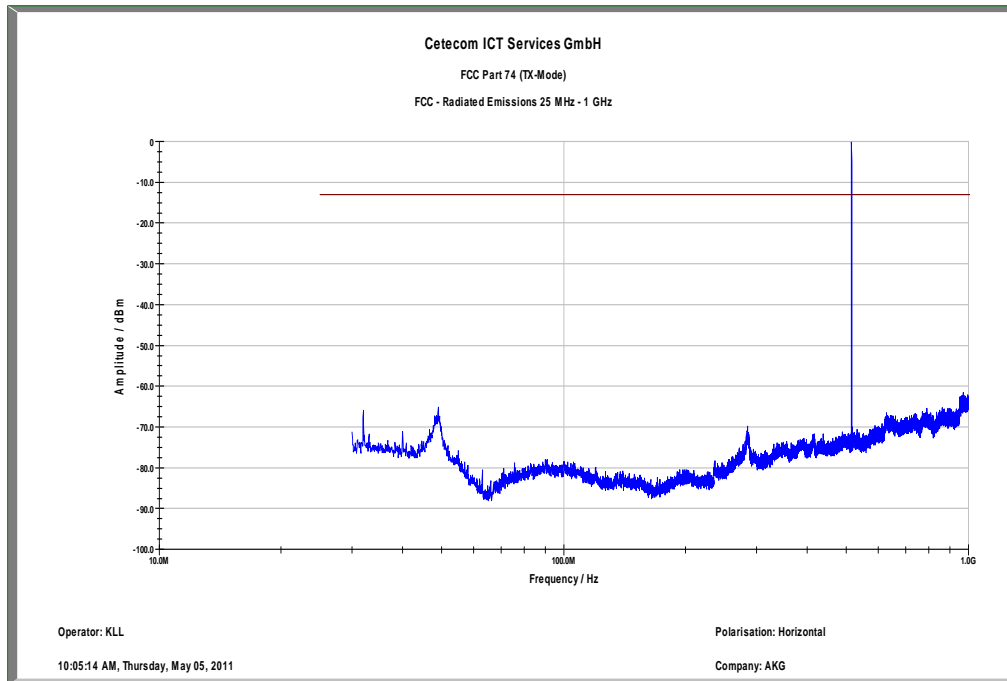

Plot 10: Band VII (500.1MHz-530.5MHz) middle channel, 1 GHz – 12.75 GHz, antenna horizontal

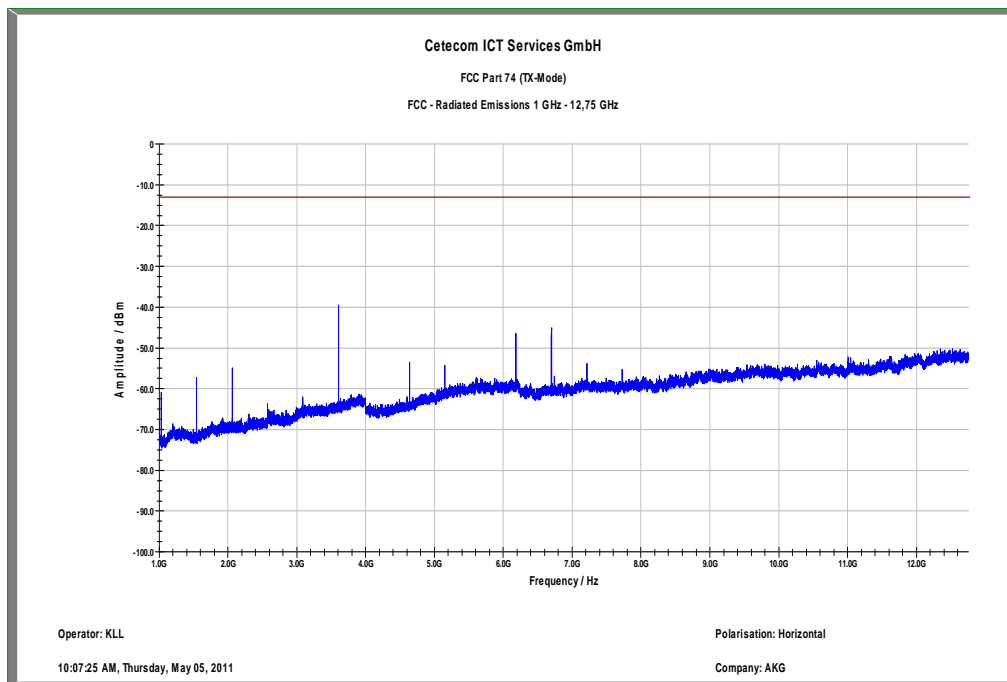

Plot 11: Band VII (500.1MHz-530.5MHz) high channel, <30MHz

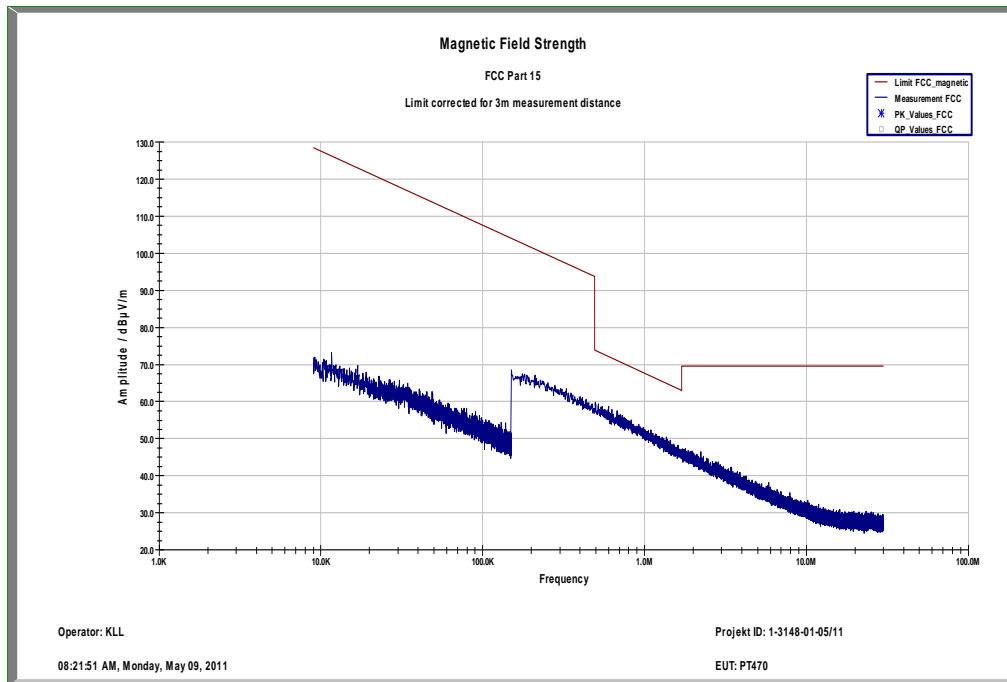

Plot 12: Band VII (500.1MHz-530.5MHz) high channel, 30 MHz – 1 GHz, antenna vertical

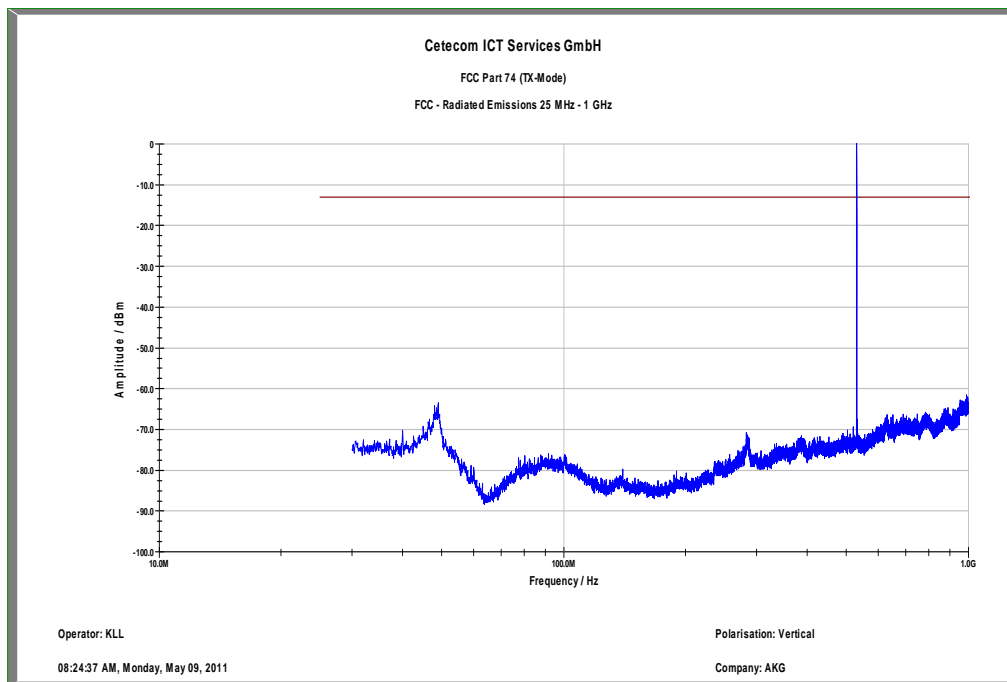

Plot 13: Band VII (500.1MHz-530.5MHz) high channel, 1 GHz – 12.75 GHz, antenna vertical

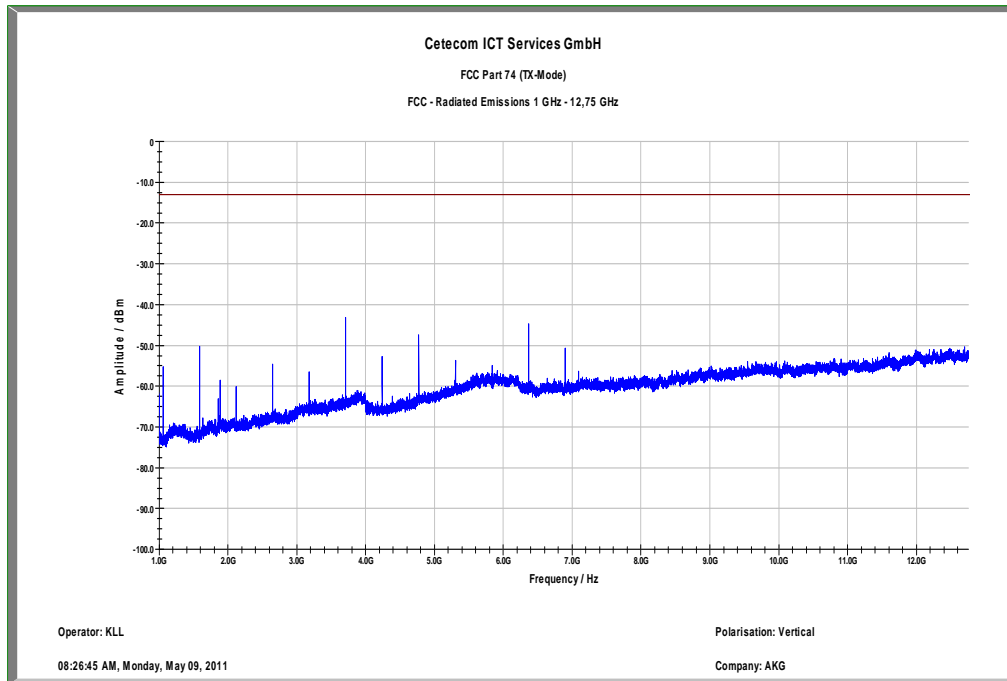

Plot 14: Band VII (500.1MHz-530.5MHz) high channel, 30 MHz – 1 GHz, antenna horizontal

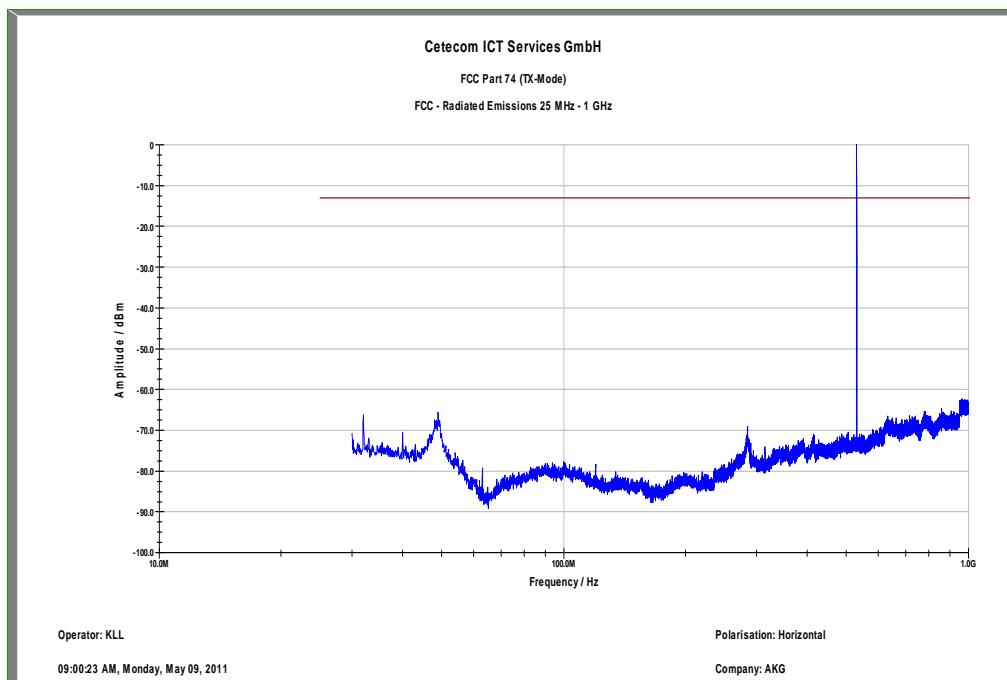

Plot 15: Band VII (500.1MHz-530.5MHz) high channel, 1 GHz – 12.75 GHz, antenna horizontal

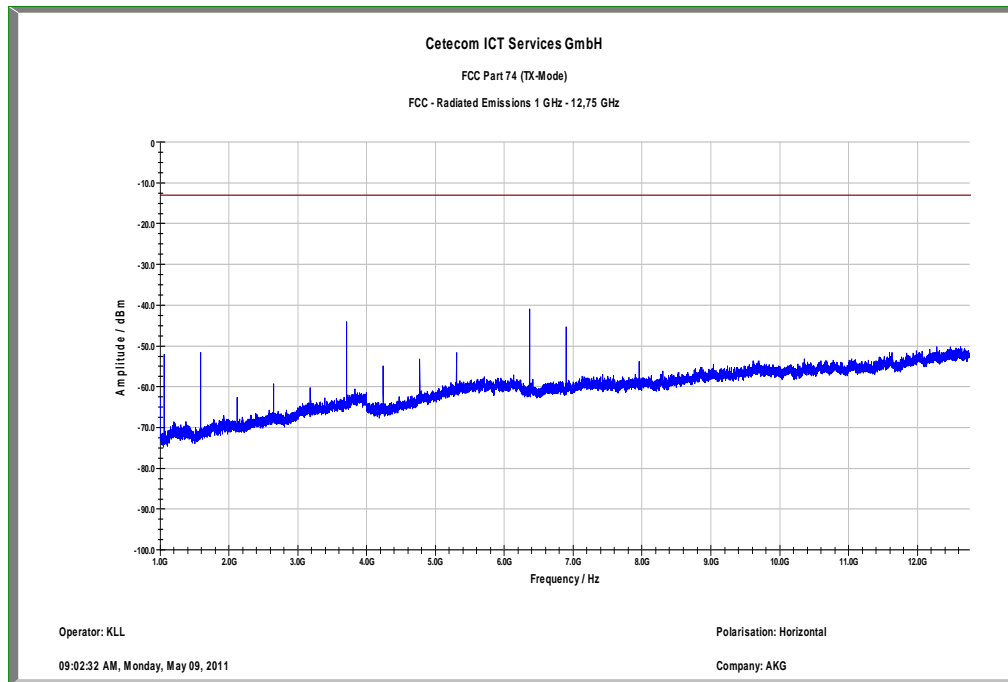

Plot 16: Band VIII (570.1MHz-600.5MHz) low channel, <30MHz

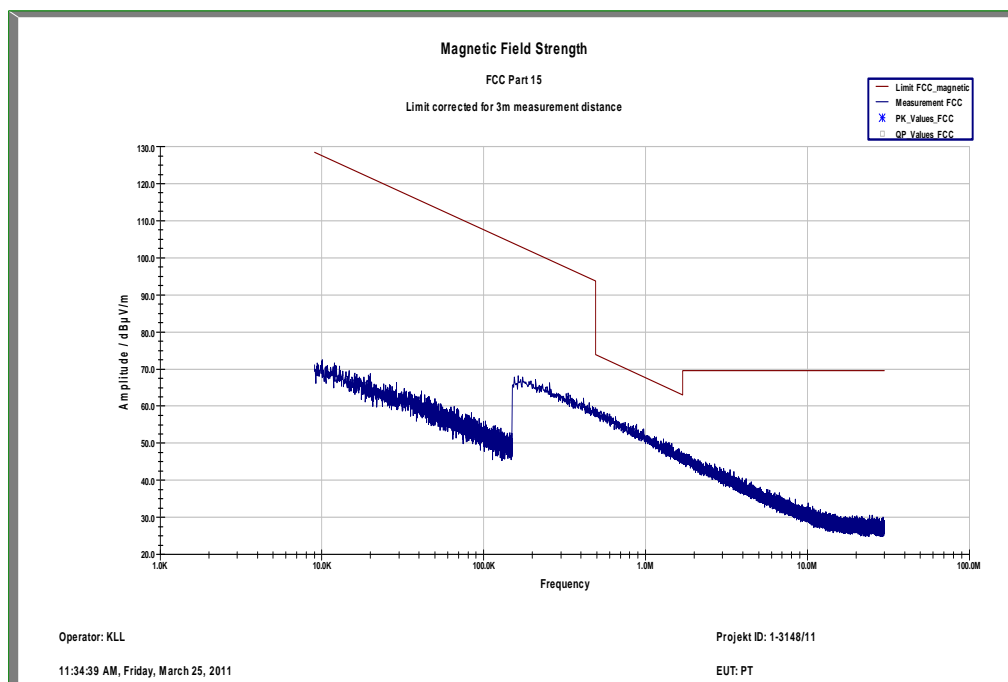

Plot 17: Band VIII (570.1MHz-600.5MHz) low channel, 30 MHz – 1 GHz, antenna vertical

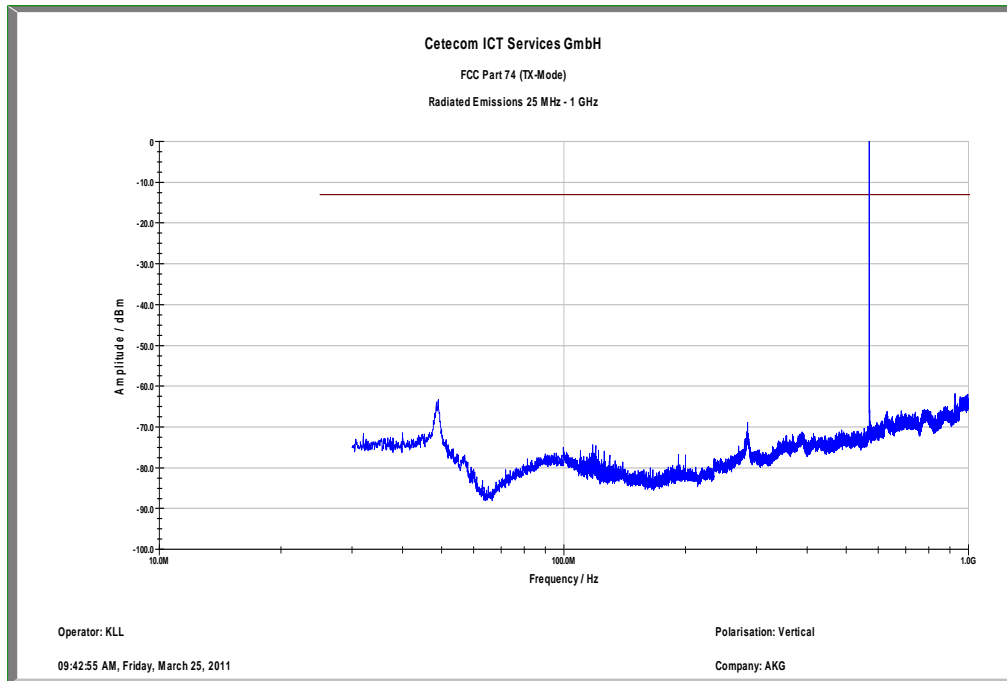

Plot 18: Band VIII (570.1MHz-600.5MHz) low channel, 1 GHz – 12.75 GHz, antenna vertical

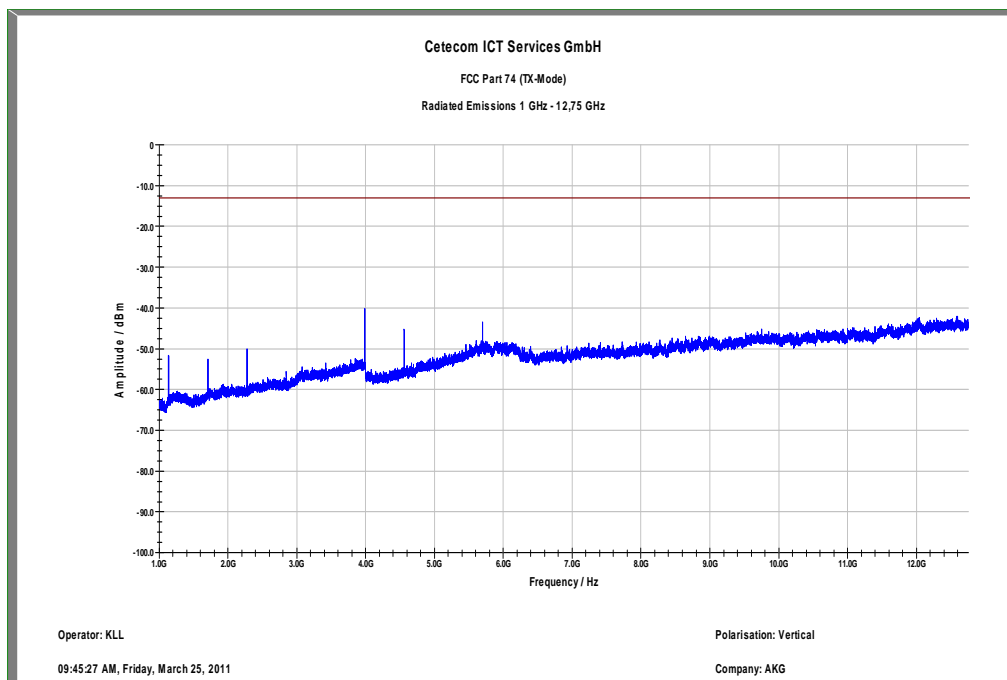

Plot 19: Band VIII (570.1MHz-600.5MHz) low channel, 30 MHz – 1 GHz, antenna horizontal

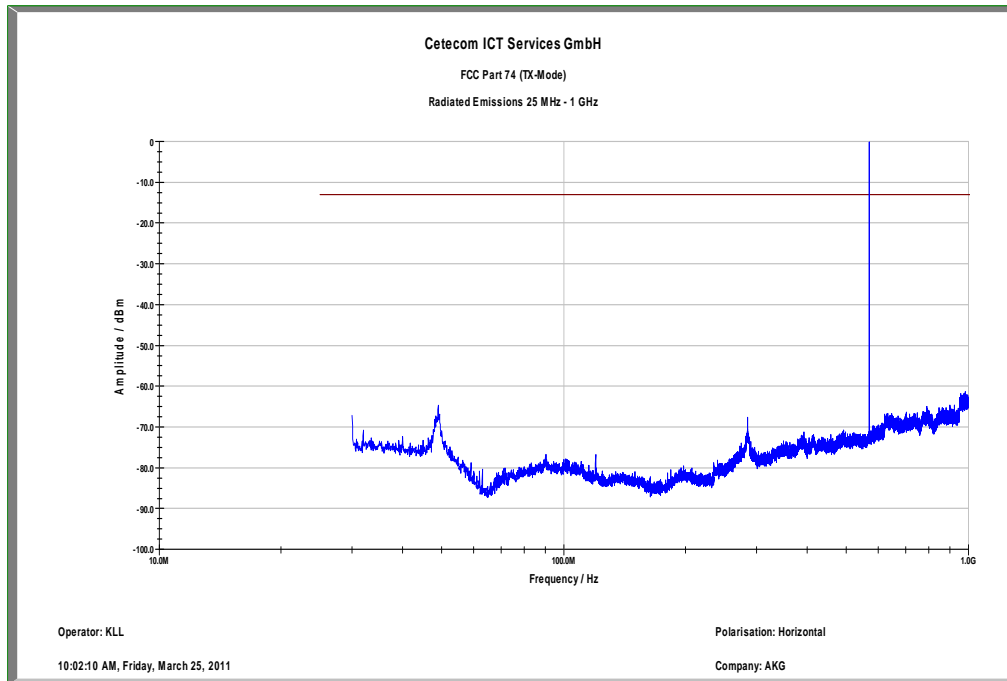

Plot 20: Band VIII (570.1MHz-600.5MHz) low channel, 1 GHz – 12.75 GHz, antenna horizontal

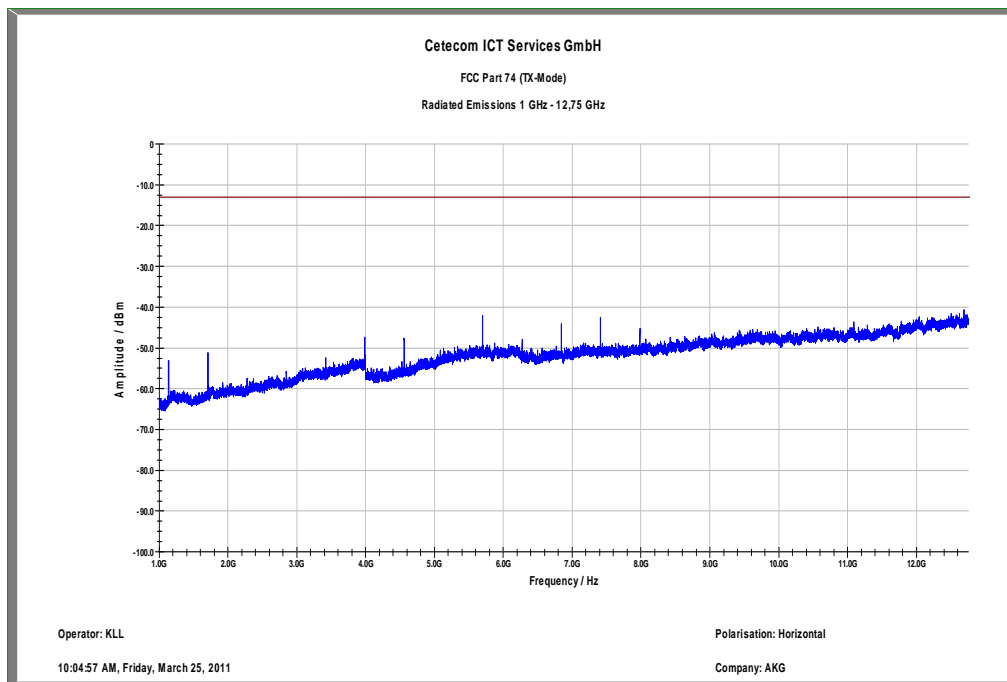

Plot 21: Band VIII (570.1MHz-600.5MHz) middle channel, <30MHz

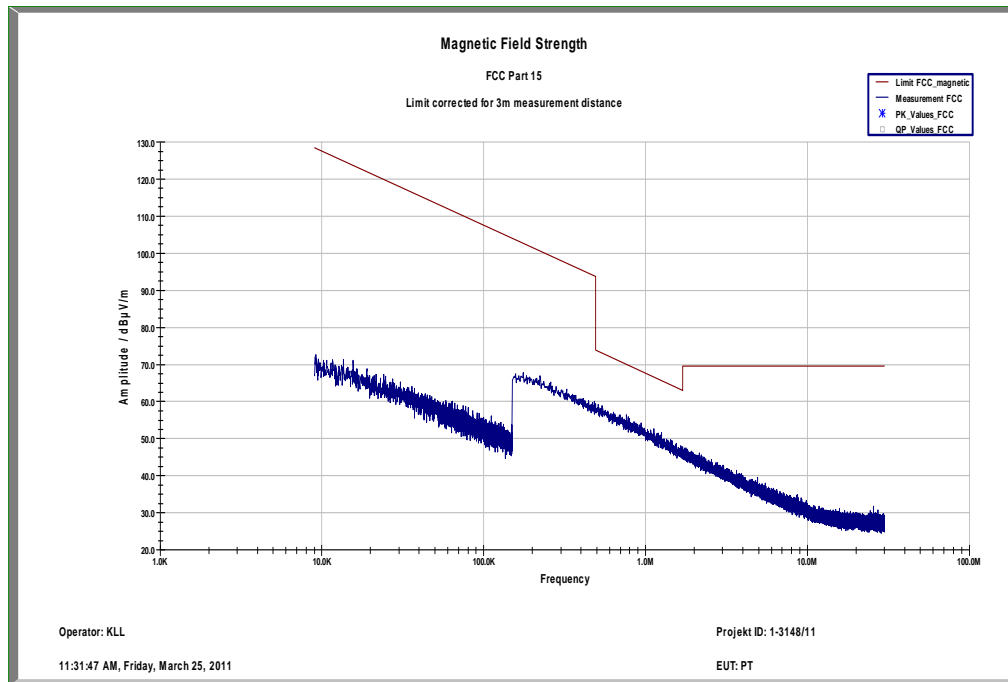

Plot 22: Band VIII (570.1MHz-600.5MHz) middle channel, 30 MHz – 1 GHz, antenna vertical

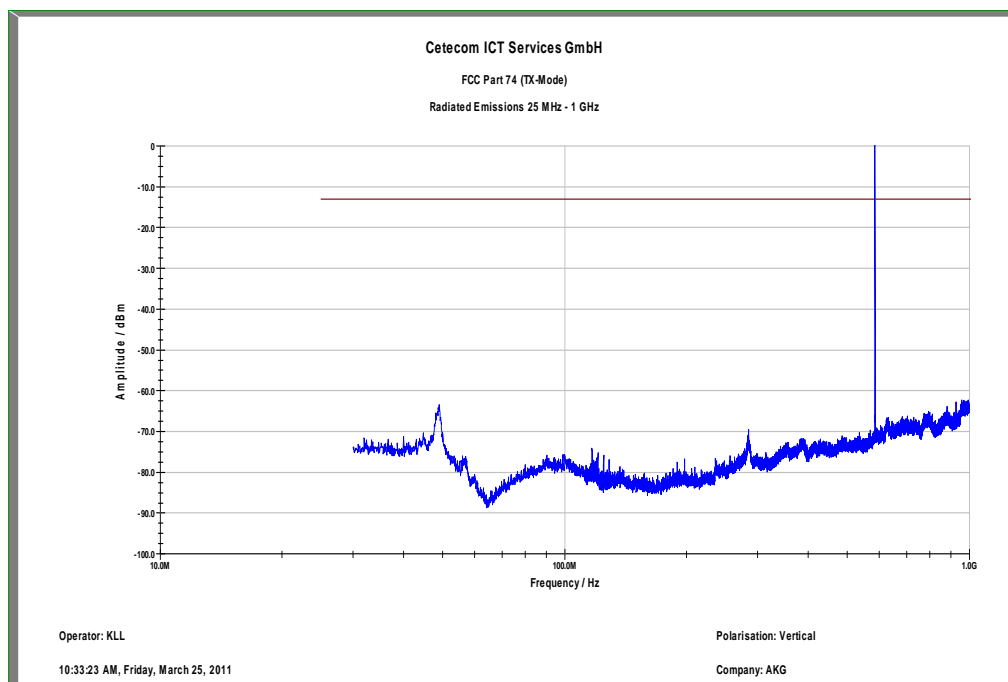



Plot 23: Band VIII (570.1MHz-600.5MHz) middle channel, 1 GHz – 12.75 GHz, antenna vertical

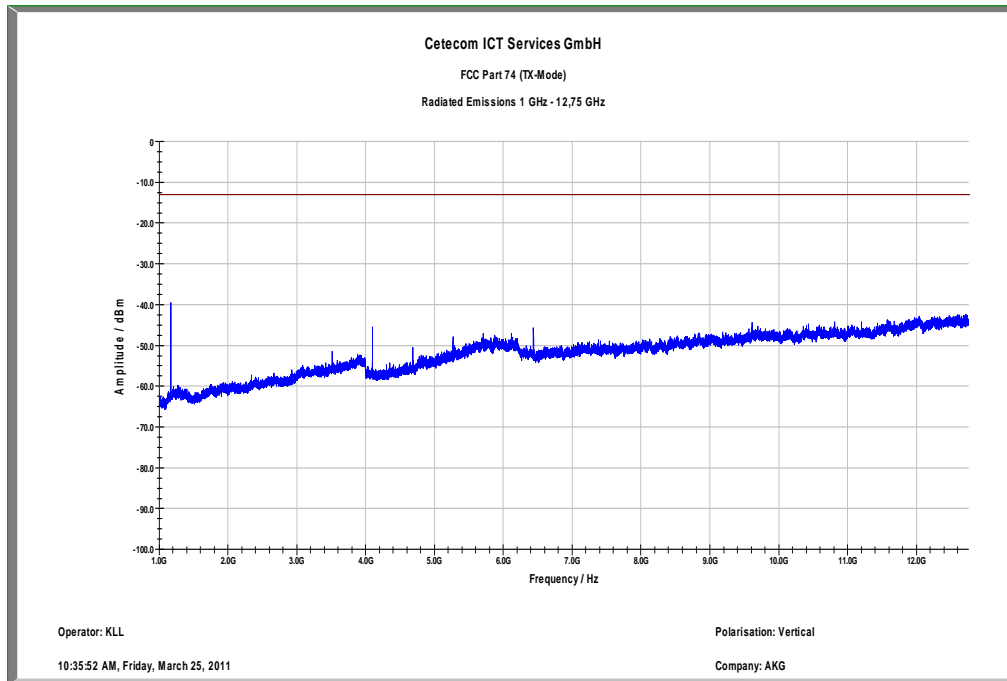

Plot 24: Band VIII (570.1MHz-600.5MHz) middle channel, 30 MHz – 1 GHz, antenna horizontal

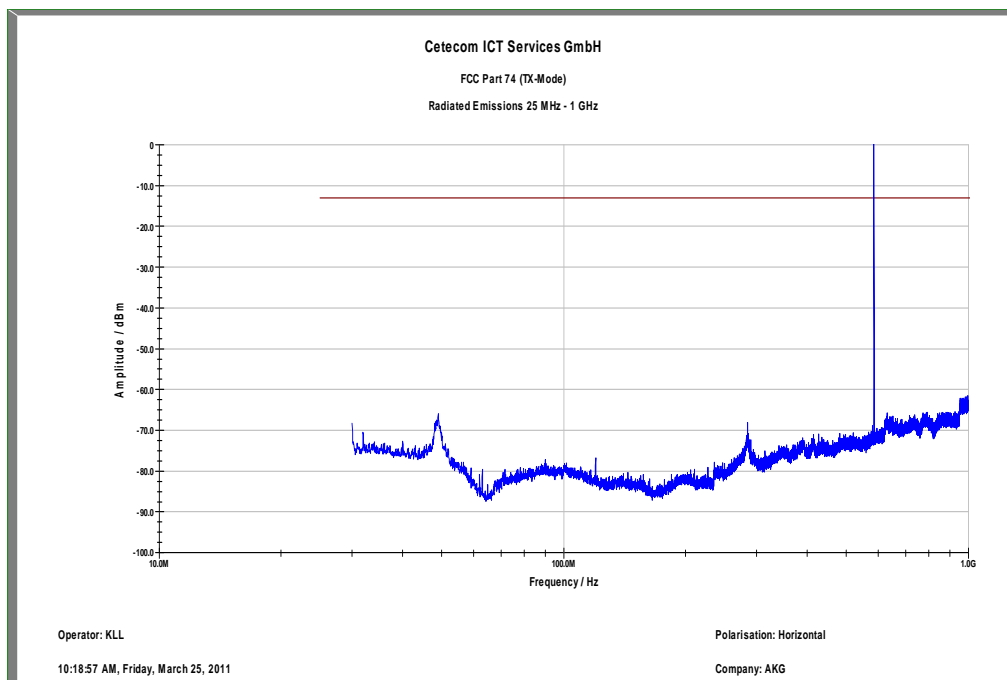

Plot 25: Band VIII (570.1MHz-600.5MHz) middle channel, 1 GHz – 12.75 GHz, antenna horizontal

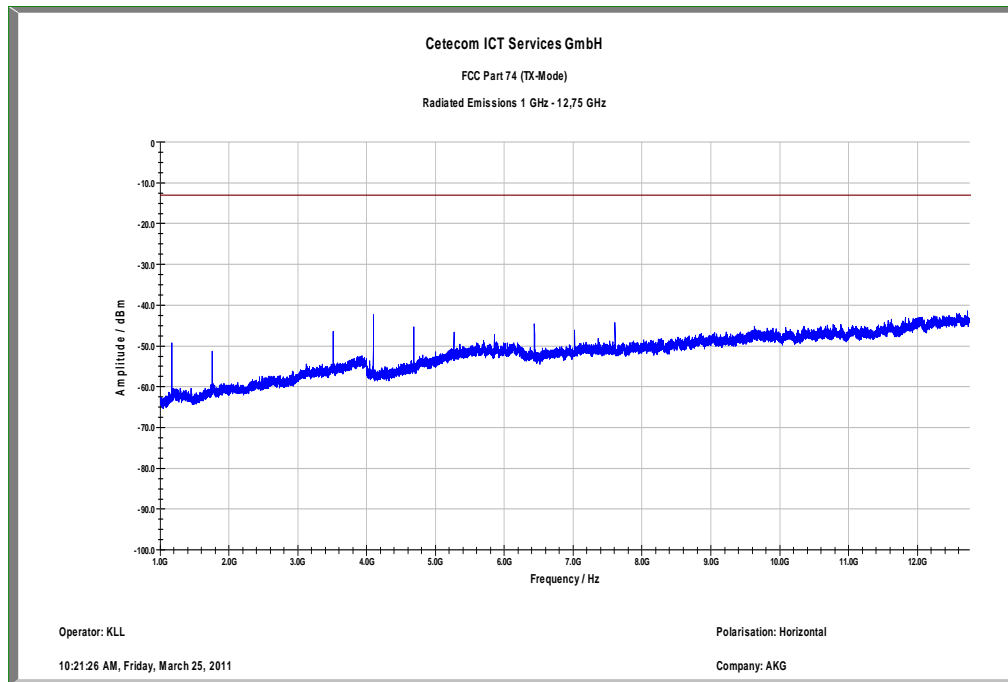

Plot 26: Band VIII (570.1MHz-600.5MHz) high channel, <30MHz

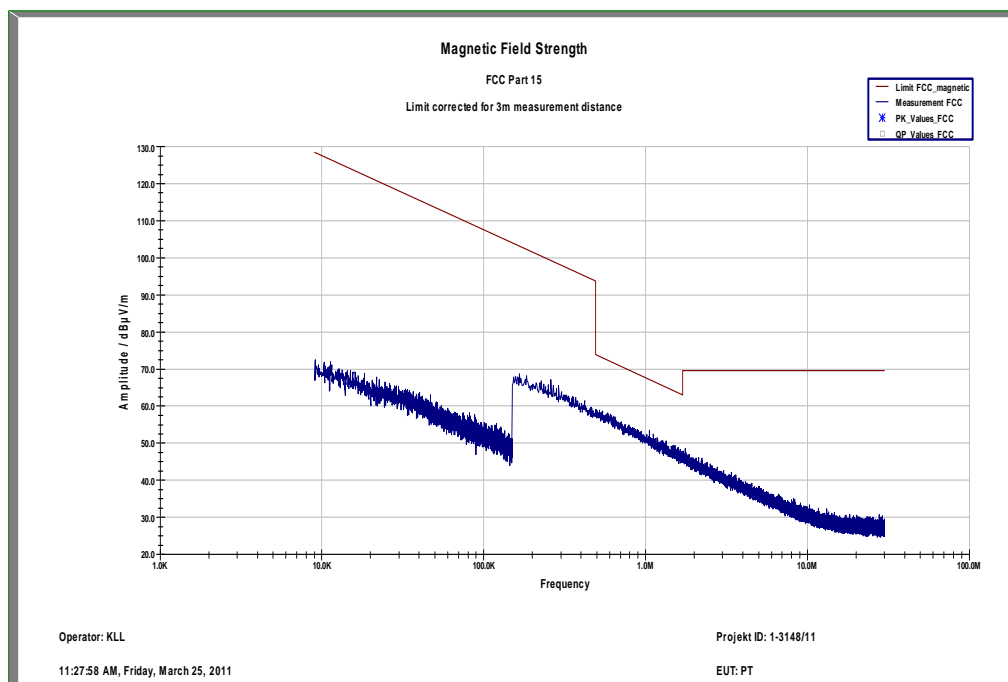

Plot 27: Band VIII (570.1MHz-600.5MHz) high channel, 30 MHz – 1 GHz, antenna vertical

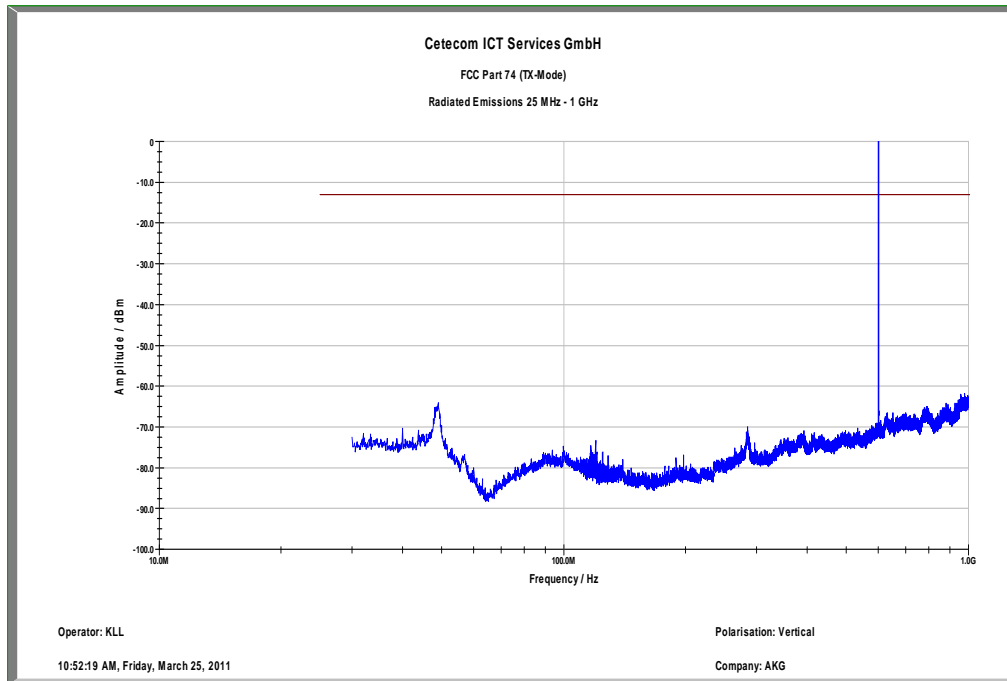

Plot 28: Band VIII (570.1MHz-600.5MHz) high channel, 1 GHz – 12.75 GHz, antenna vertical

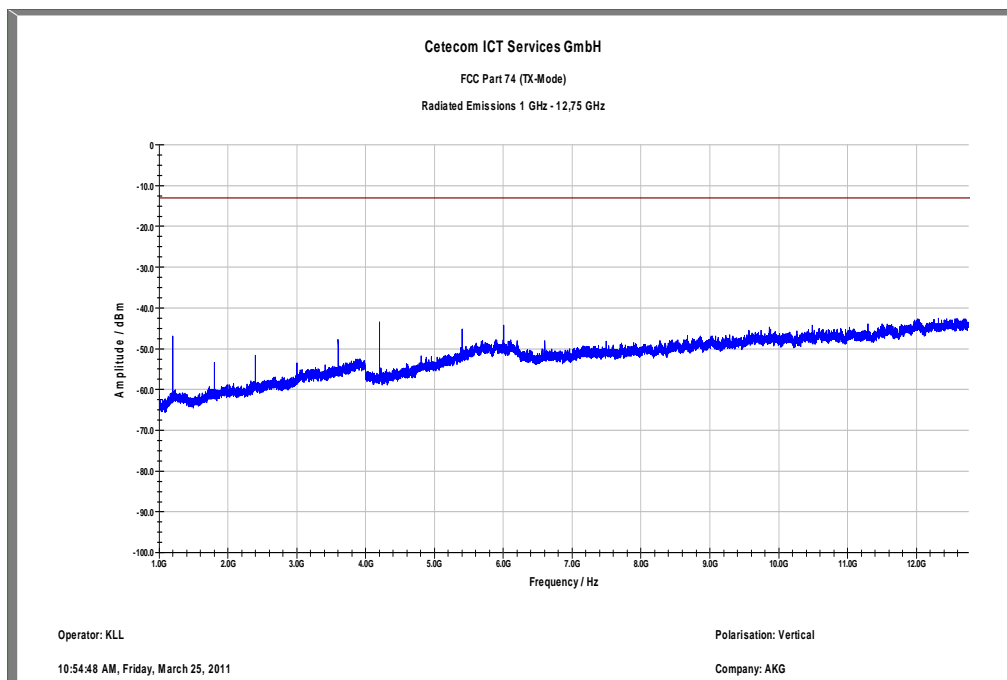

Plot 29: Band VIII (570.1MHz-600.5MHz) high channel, 30 MHz – 1 GHz, antenna horizontal

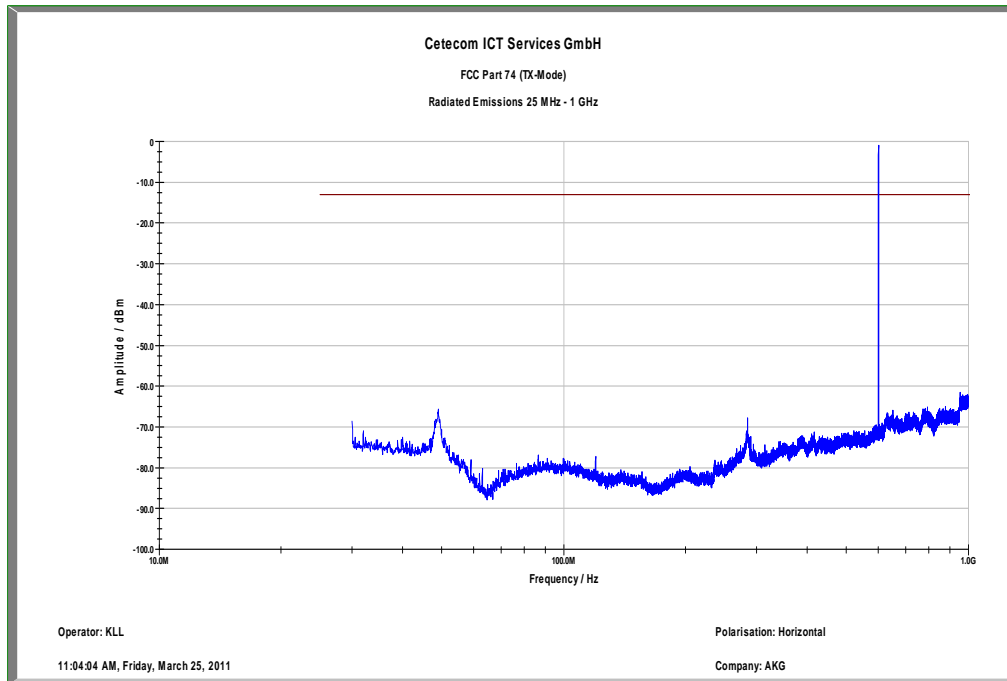

Plot 30: Band VIII (570.1MHz-600.5MHz) high channel, 1 GHz – 12.75 GHz, antenna horizontal

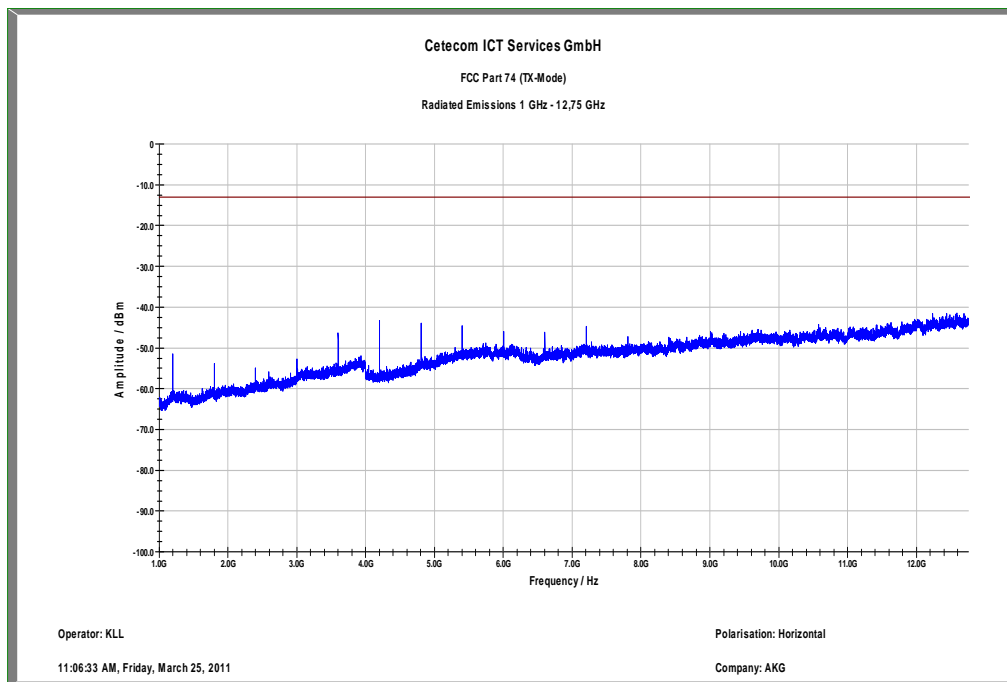

Plot 31: Band IX (600.0MHz-605.9MHz) low channel, <30MHz

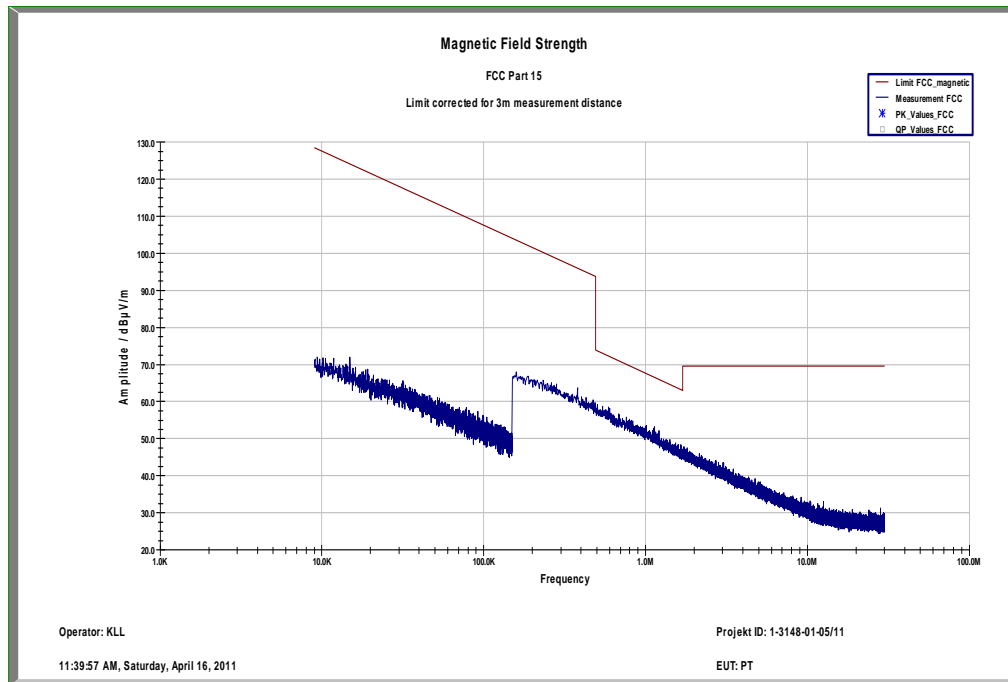

Plot 32: Band IX (600.0MHz-605.9MHz) low channel, 30 MHz – 1 GHz, antenna vertical

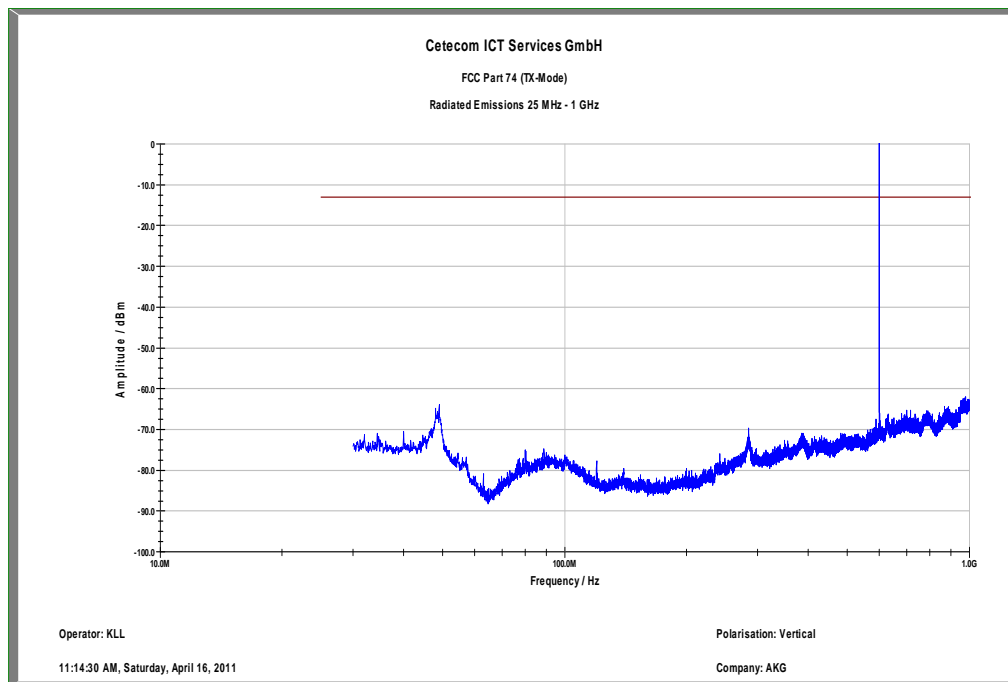

Plot 33: Band IX (600.0MHz-605.9MHz) low channel, 1 GHz – 12.75 GHz, antenna vertical

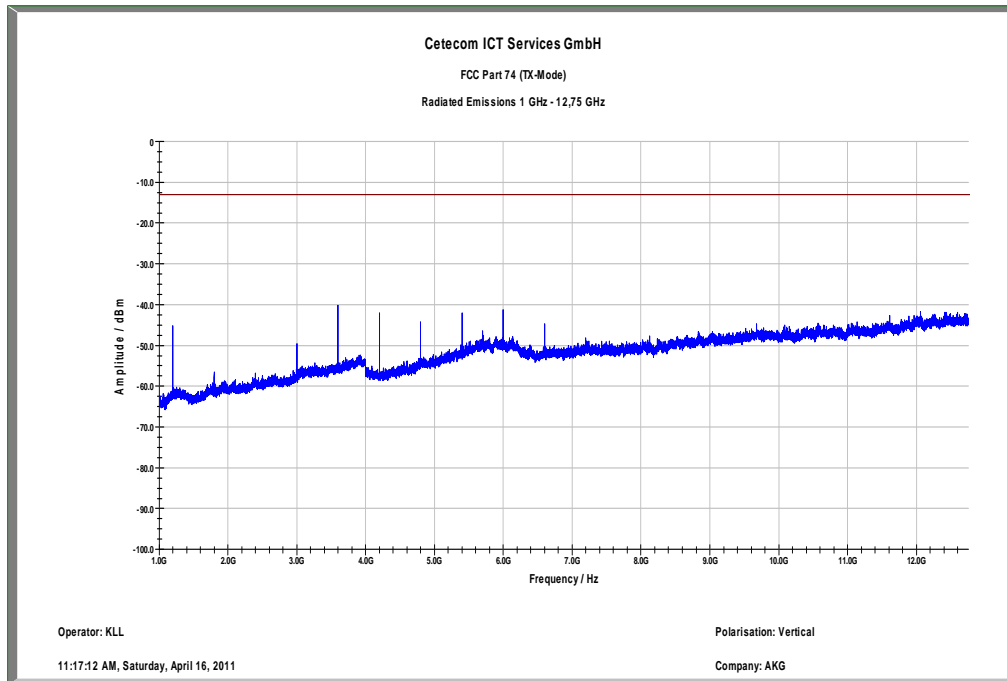

Plot 34: Band IX (600.0MHz-605.9MHz) low channel, 30 MHz – 1 GHz, antenna horizontal

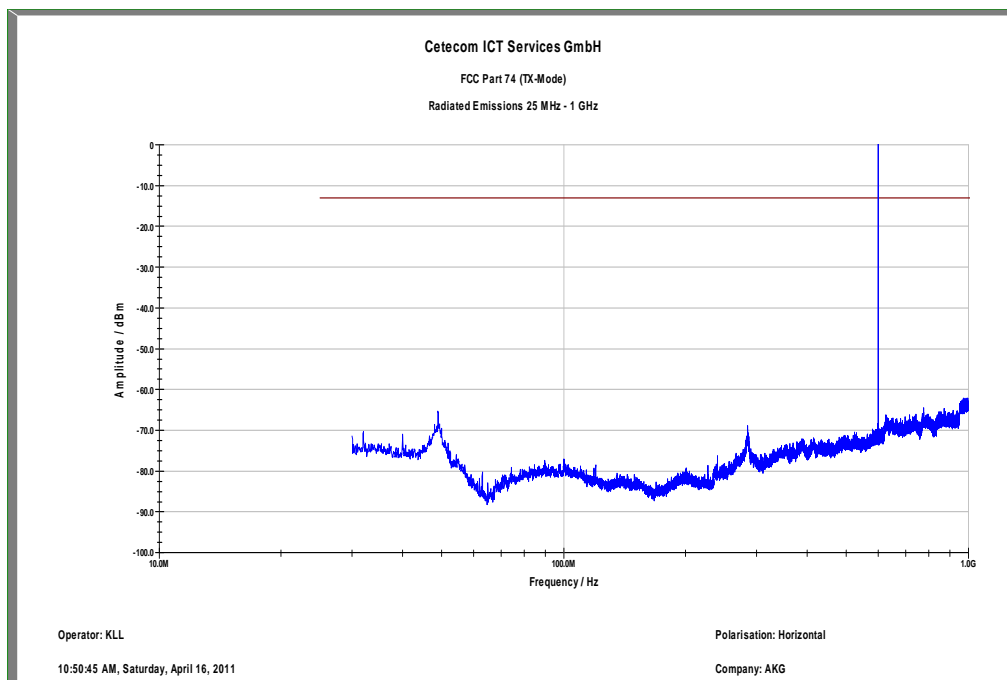

Plot 35: Band IX (600.0MHz-605.9MHz) low channel, 1 GHz – 12.75 GHz, antenna horizontal

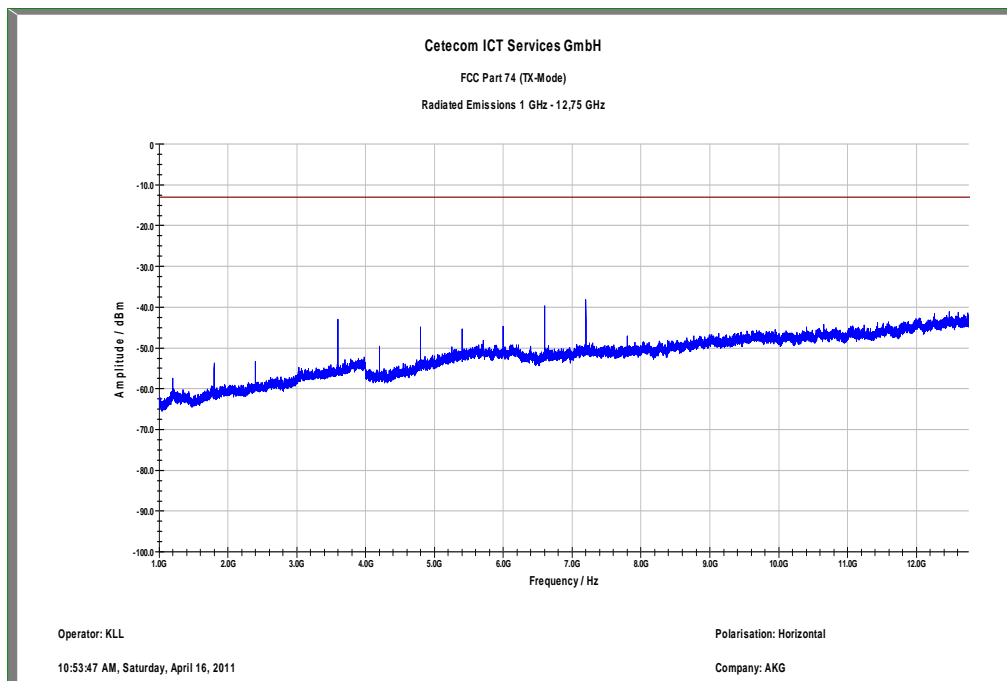

Plot 36: Band IX (600.0MHz-605.9MHz) high channel, <30MHz

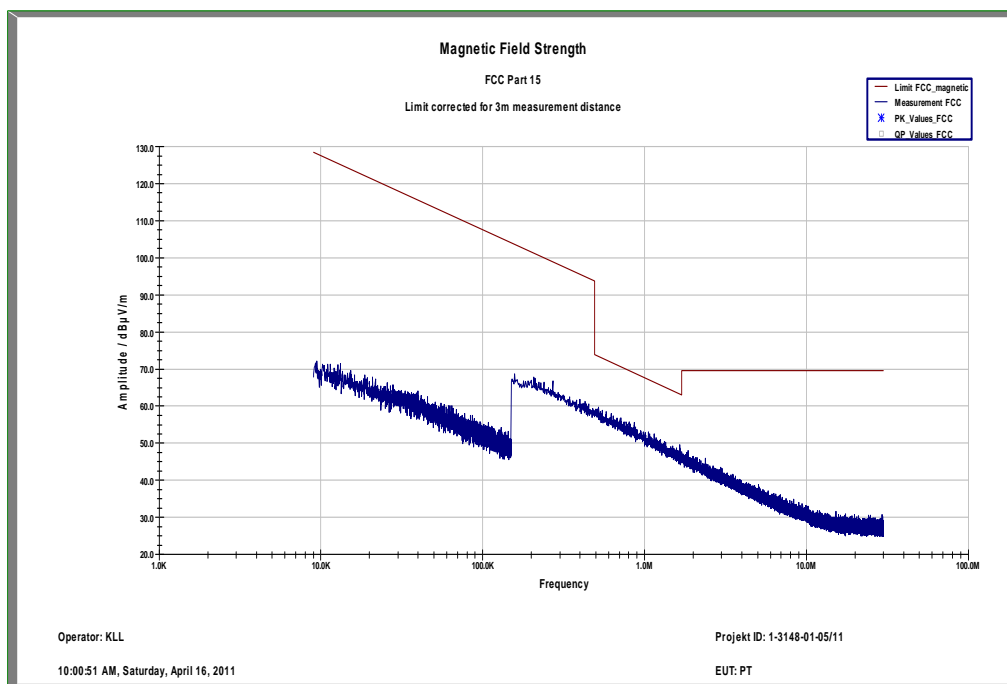

Plot 37: Band IX (600.0MHz-605.9MHz) high channel, 30 MHz – 1 GHz, antenna vertical

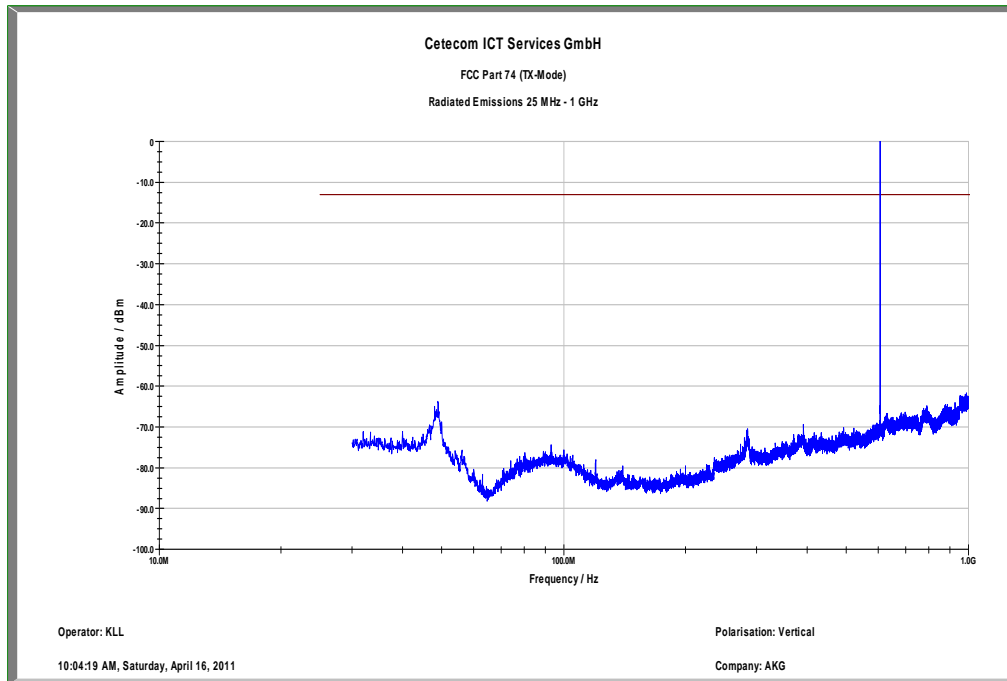

Plot 38: Band IX (600.0MHz-605.9MHz) high channel, 1 GHz – 12.75 GHz, antenna vertical

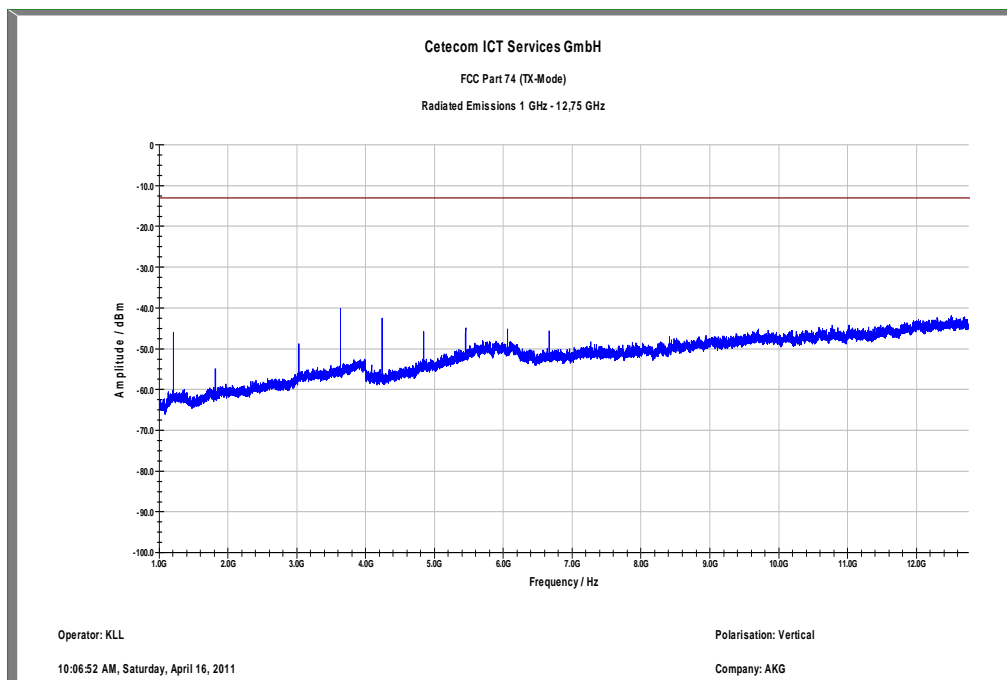



Plot 39: Band IX (600.0MHz-605.9MHz) high channel, 30 MHz – 1 GHz, antenna horizontal

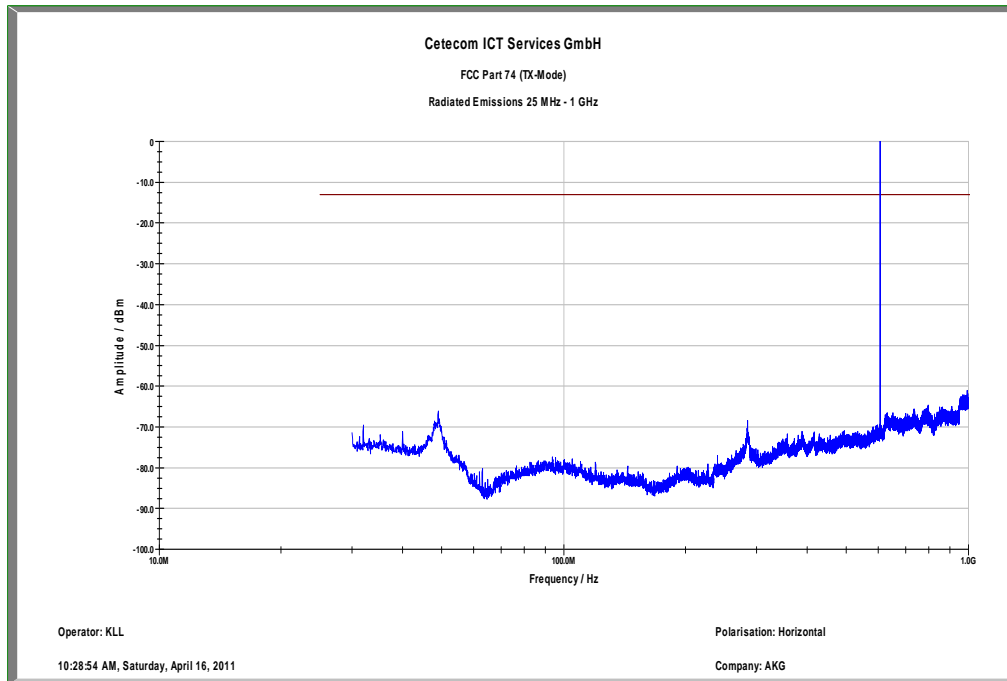

Plot 40: Band IX (600.0MHz-605.9MHz) high channel, 1 GHz – 12.75 GHz, antenna horizontal

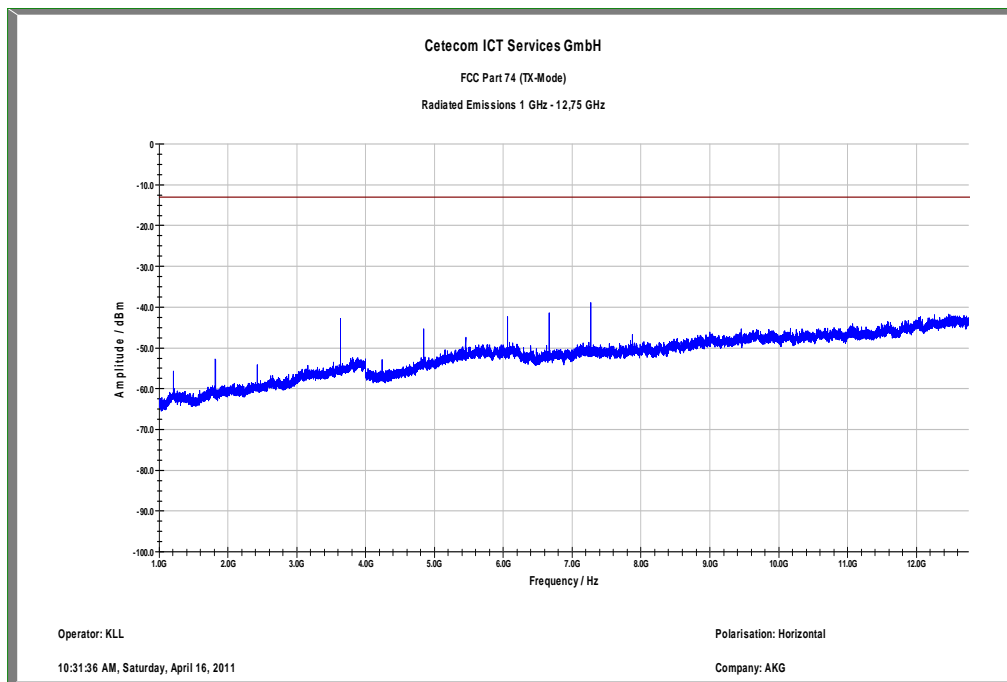

Plot 41: Band IX (614.1MHz-630.5MHz) low channel, <30MHz

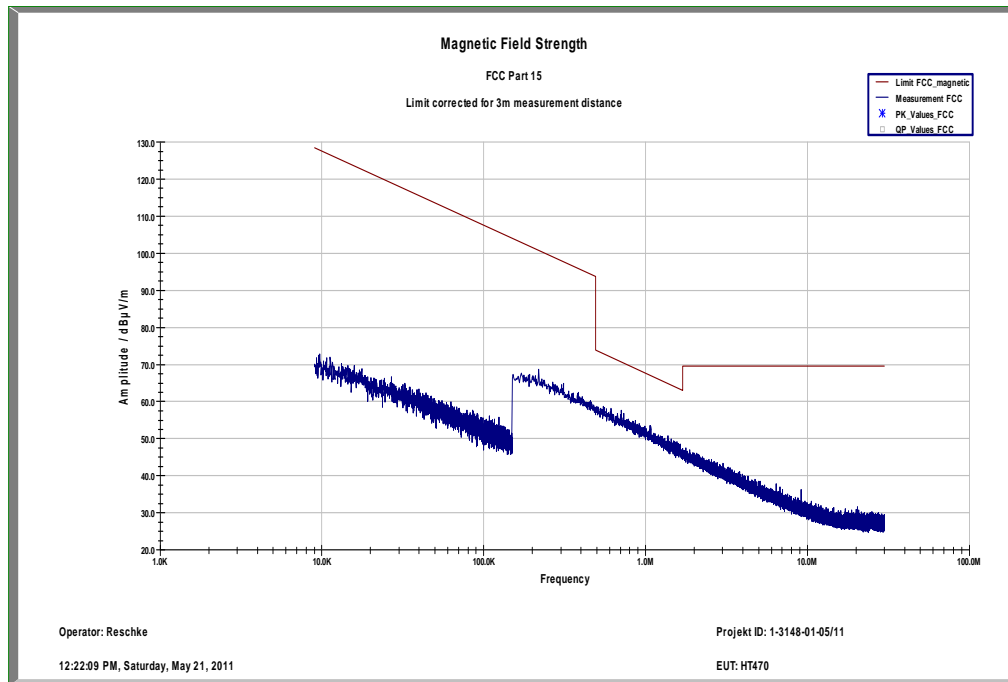

Plot 42: Band IX (614.1MHz-630.5MHz) low channel, 30 MHz – 1 GHz, antenna vertical

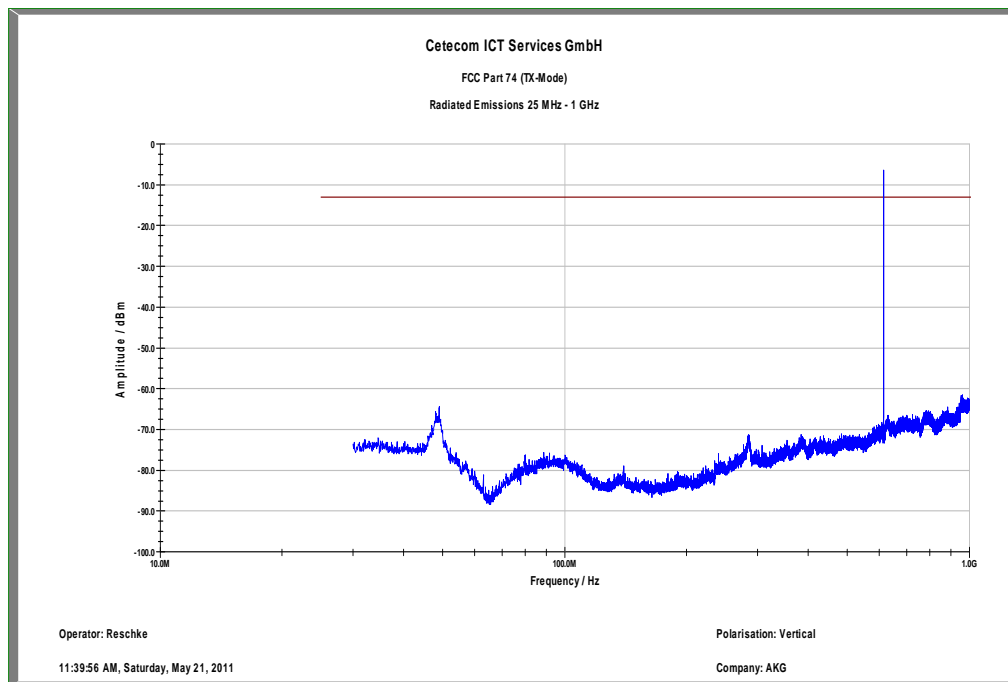

Plot 43: Band IX (614.1MHz-630.5MHz) low channel, 1 GHz – 12.75 GHz, antenna vertical

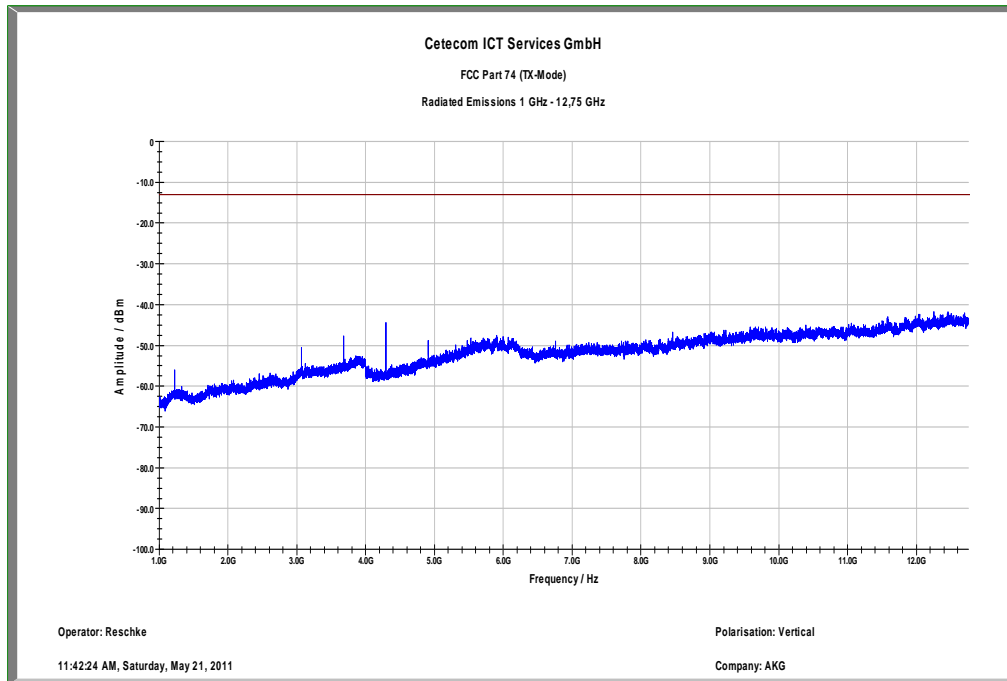

Plot 44: Band IX (614.1MHz-630.5MHz) low channel, 30 MHz – 1 GHz, antenna horizontal

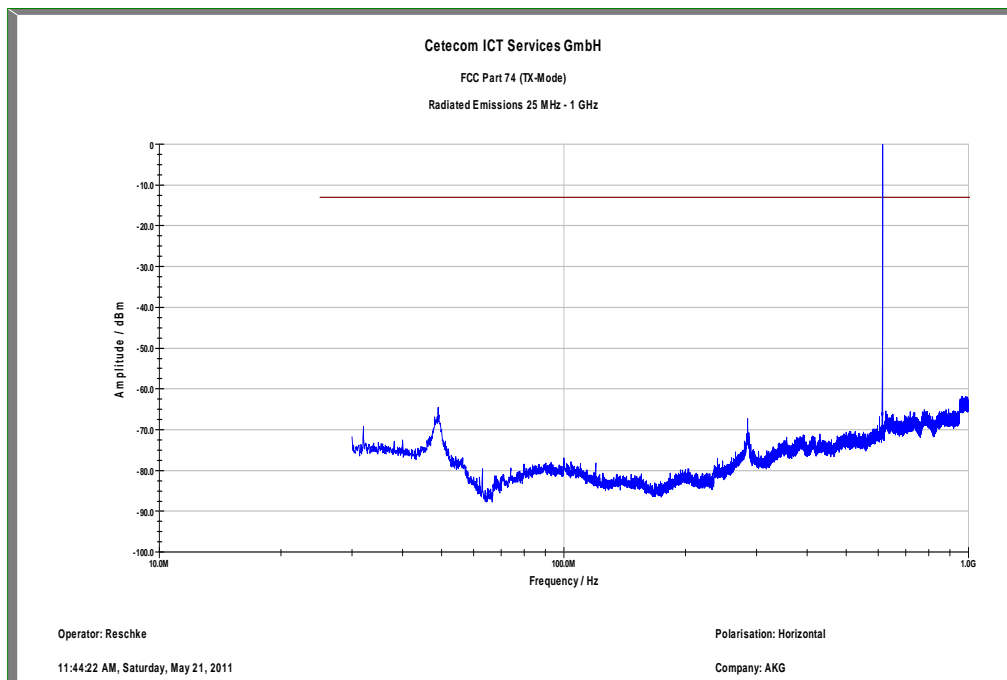

Plot 45: Band IX (614.1MHz-630.5MHz) low channel, 1 GHz – 12.75 GHz, antenna horizontal

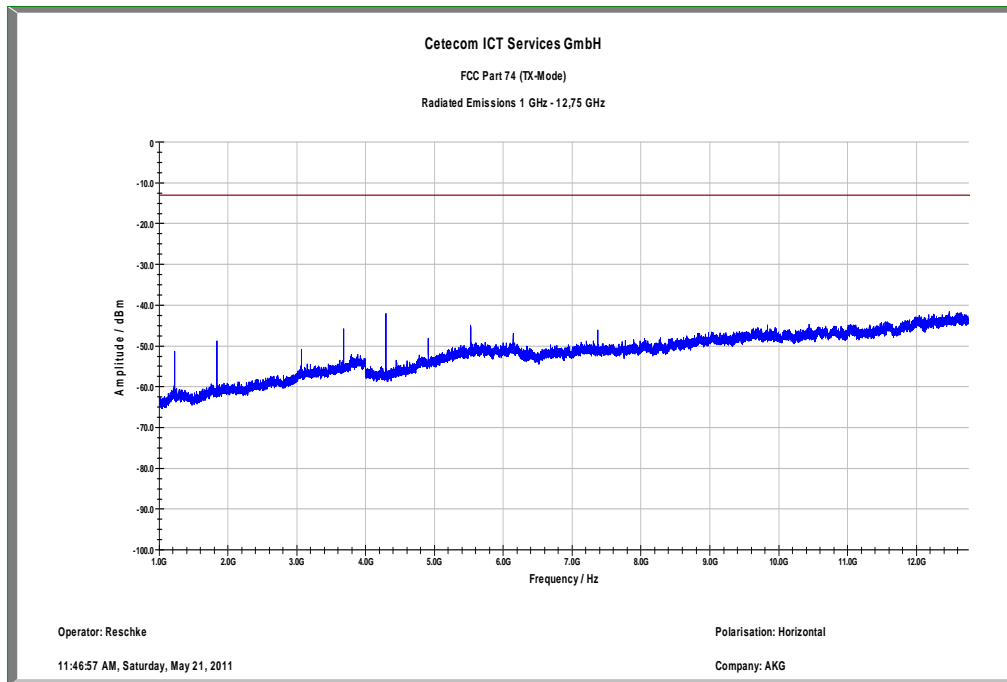

Plot 46: Band IX (614.1MHz-630.5MHz) middle channel, <30MHz

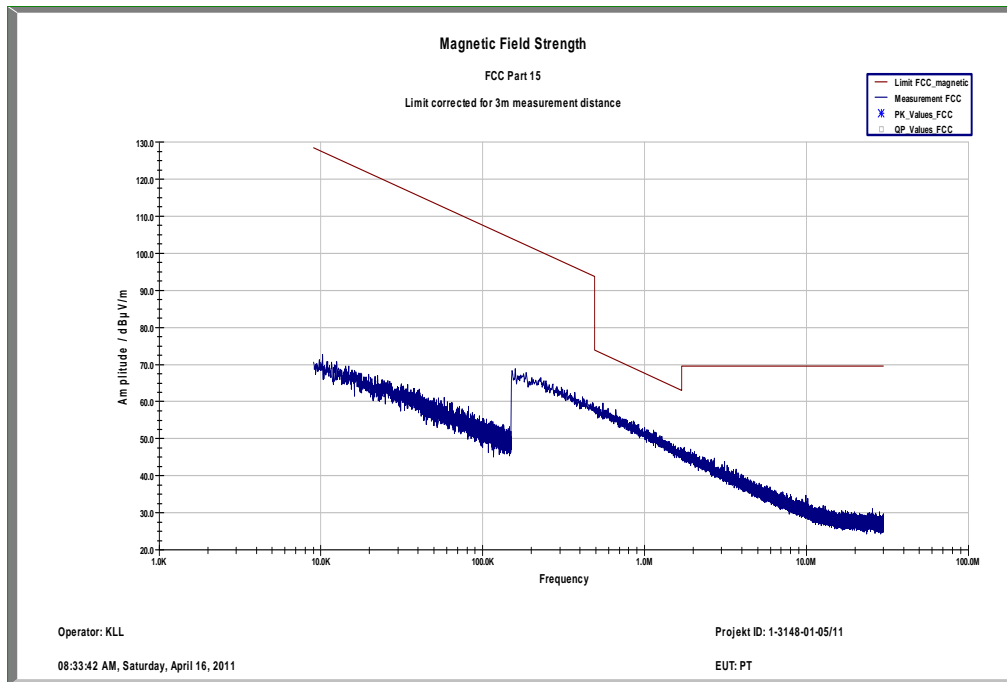

Plot 47: Band IX (614.1MHz-630.5MHz) middle channel, 30 MHz – 1 GHz, antenna vertical

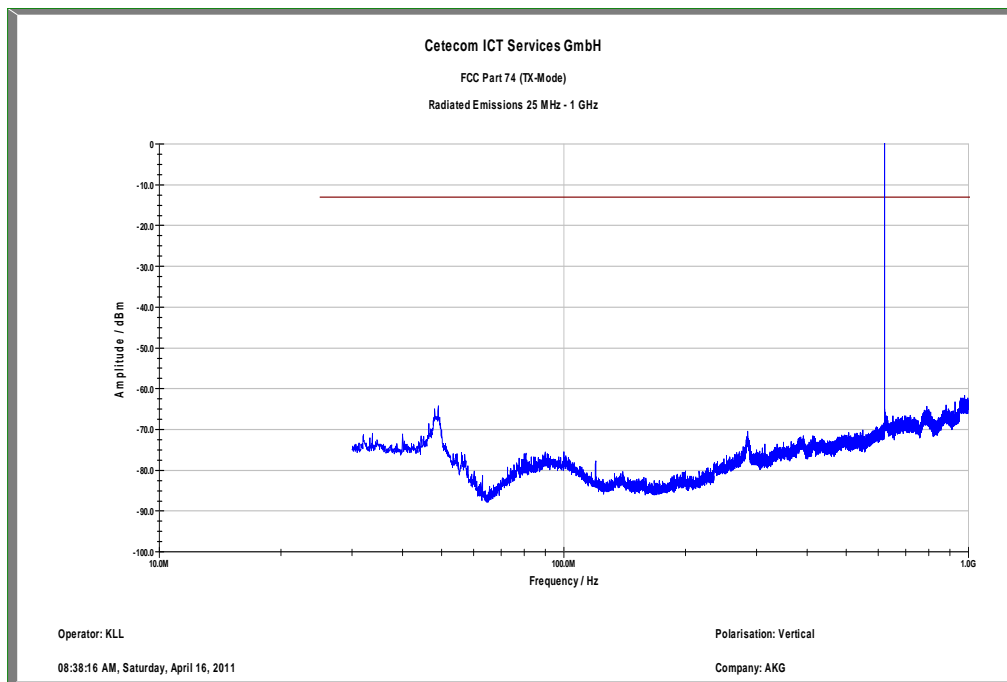

Plot 48: Band IX (614.1MHz-630.5MHz) middle channel, 1 GHz – 12.75 GHz, antenna vertical

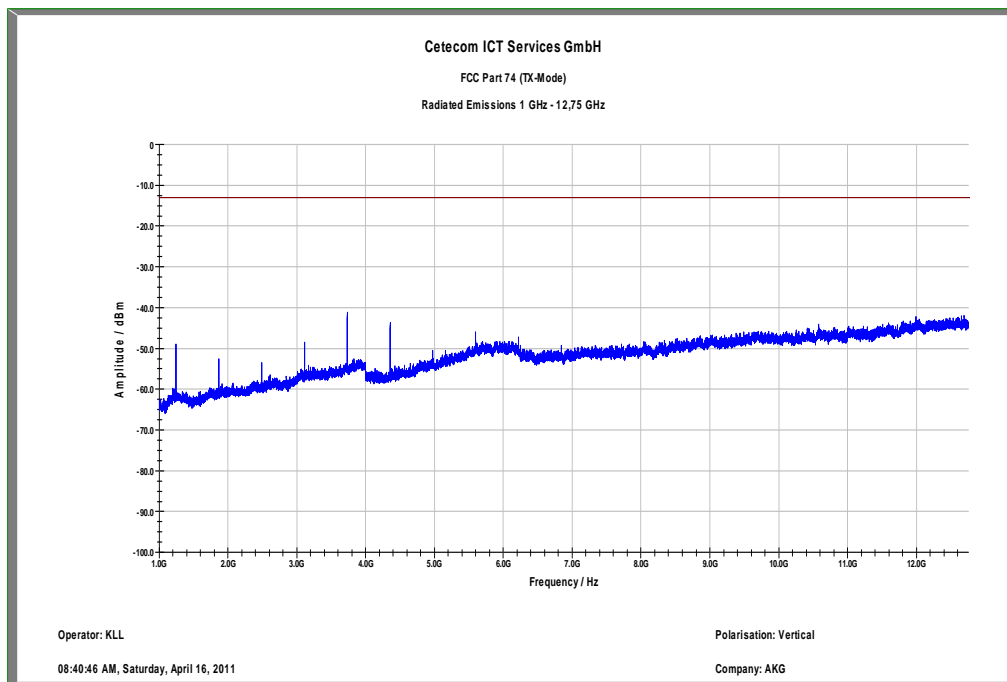

Plot 49: Band IX (614.1MHz-630.5MHz) middle channel, 30 MHz – 1 GHz, antenna horizontal

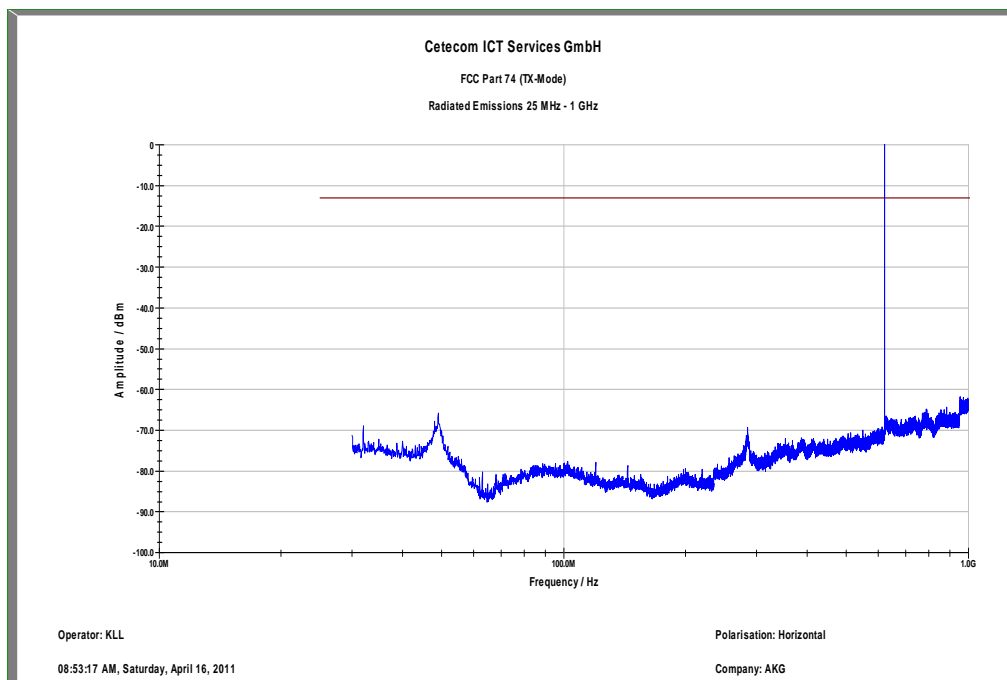

Plot 50: Band IX (614.1MHz-630.5MHz) middle channel, 1 GHz – 12.75 GHz, antenna horizontal

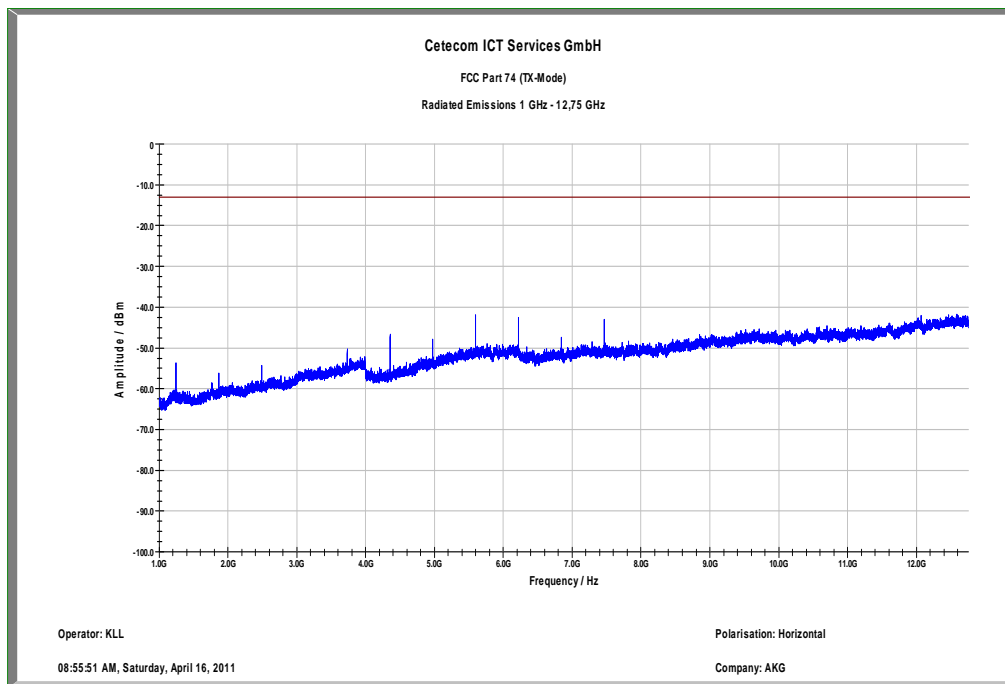

Plot 51: Band IX (614.1MHz-630.5MHz) high channel, <30MHz

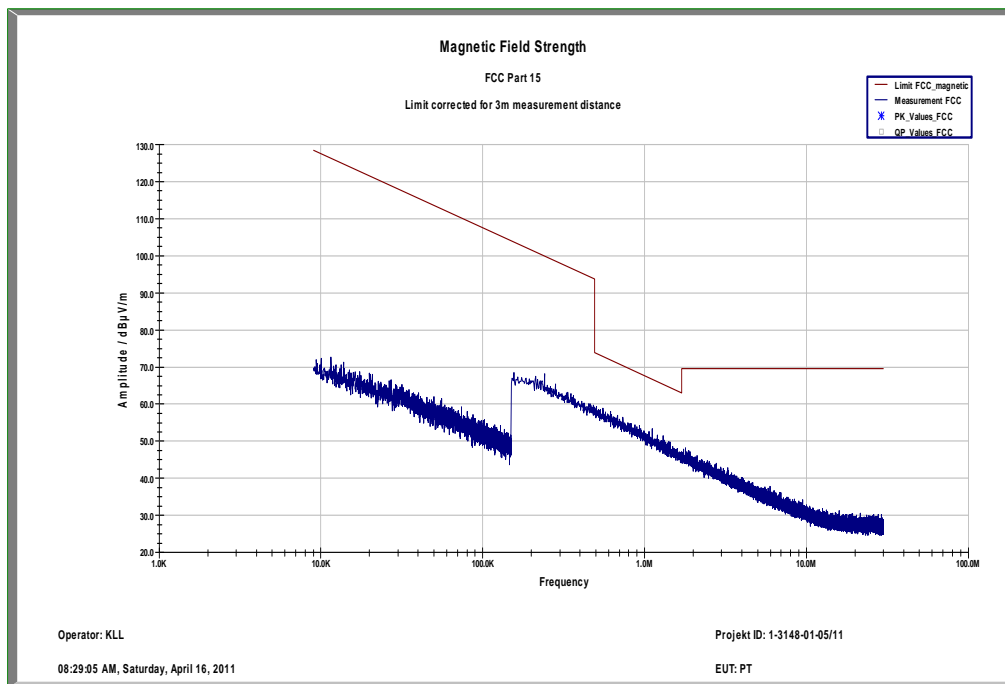

Plot 52: Band IX (614.1MHz-630.5MHz) high channel, 30 MHz – 1 GHz, antenna vertical

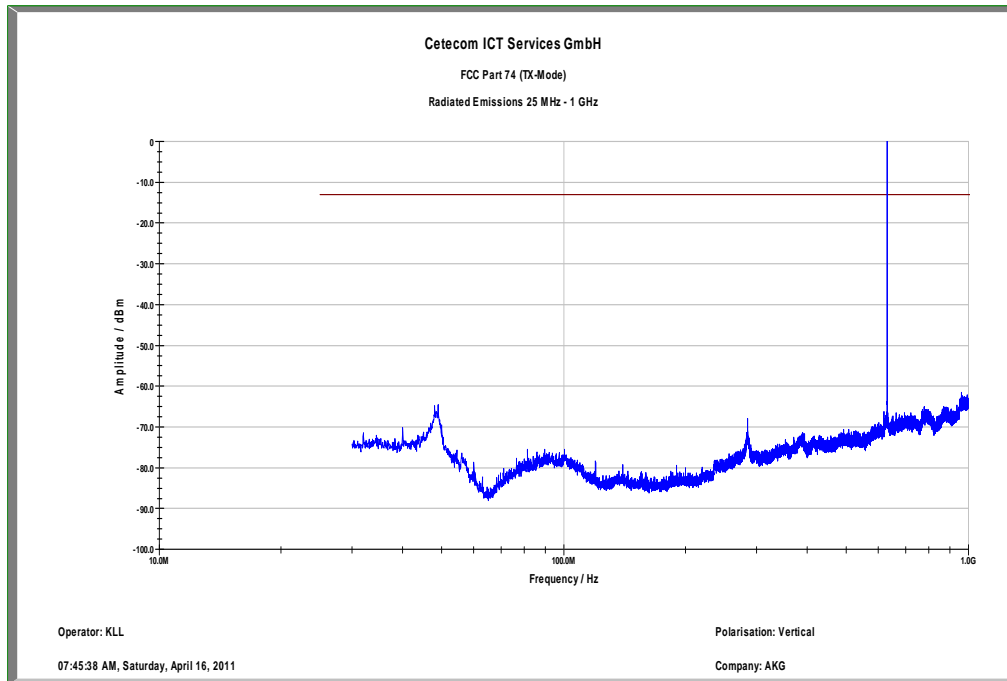

Plot 53: Band IX (614.1MHz-630.5MHz) high channel, 1 GHz – 12.75 GHz, antenna vertical

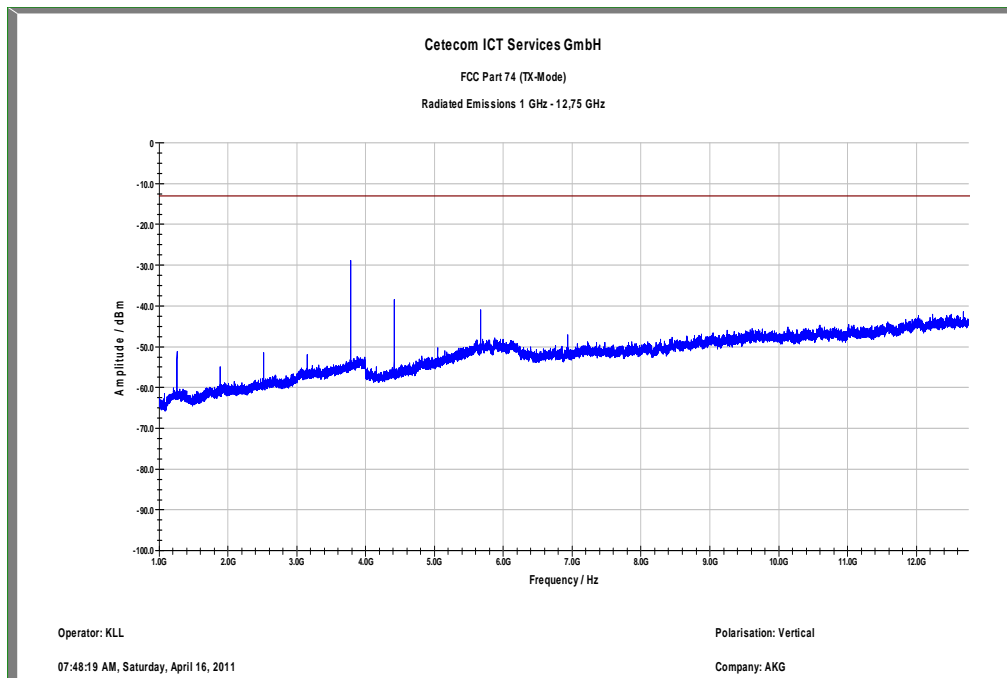



Plot 54: Band IX (614.1MHz-630.5MHz) high channel, 30 MHz – 1 GHz, antenna horizontal

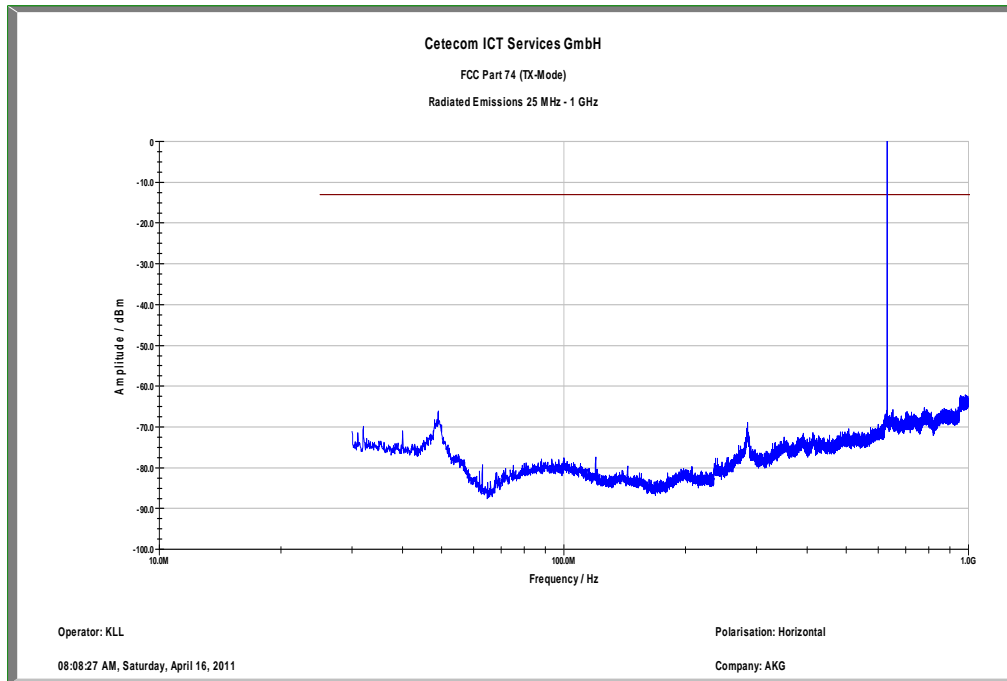

Plot 55: Band IX (614.1MHz-630.5MHz) high channel, 1 GHz – 12.75 GHz, antenna horizontal

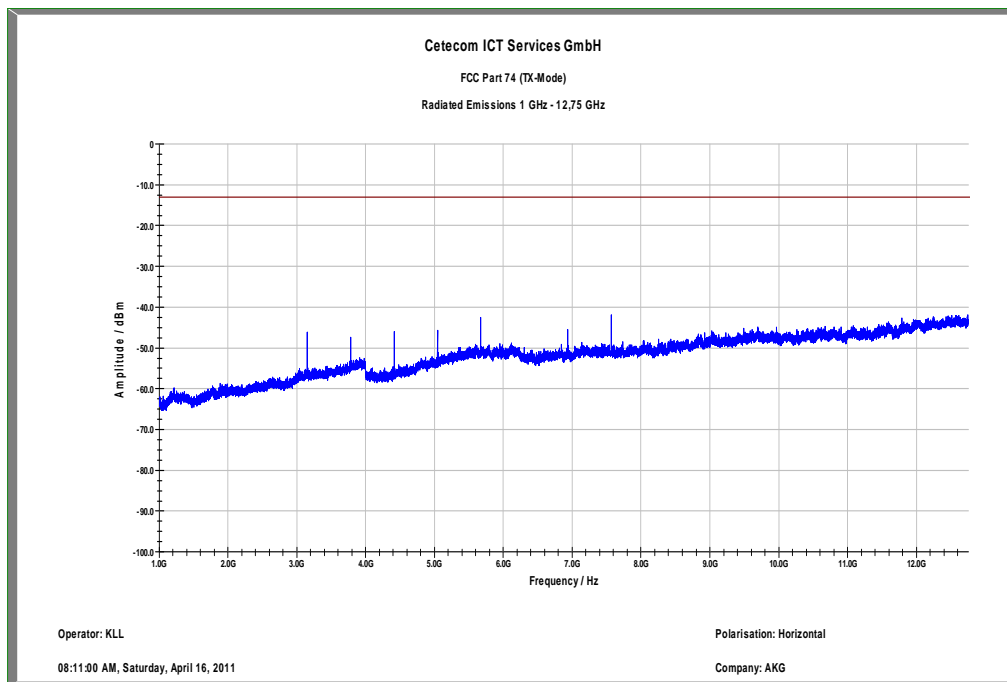

Plot 56: Band I (650.1MHz-680.0MHz) low channel, <30MHz

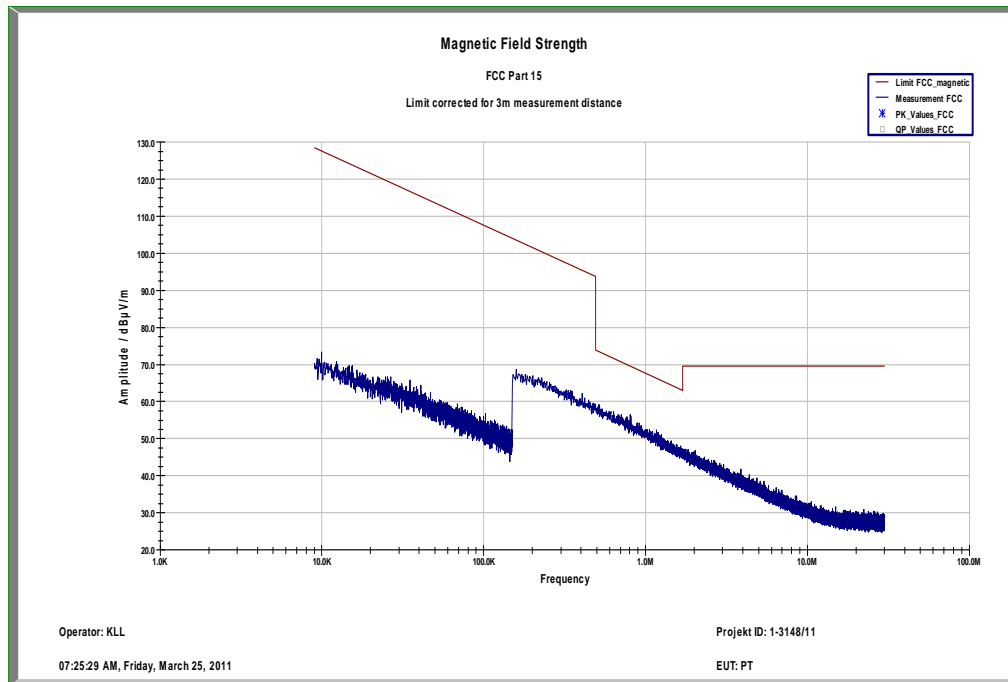

Plot 57: Band I (650.1MHz-680.0MHz) low channel, 30 MHz – 1 GHz, antenna vertical

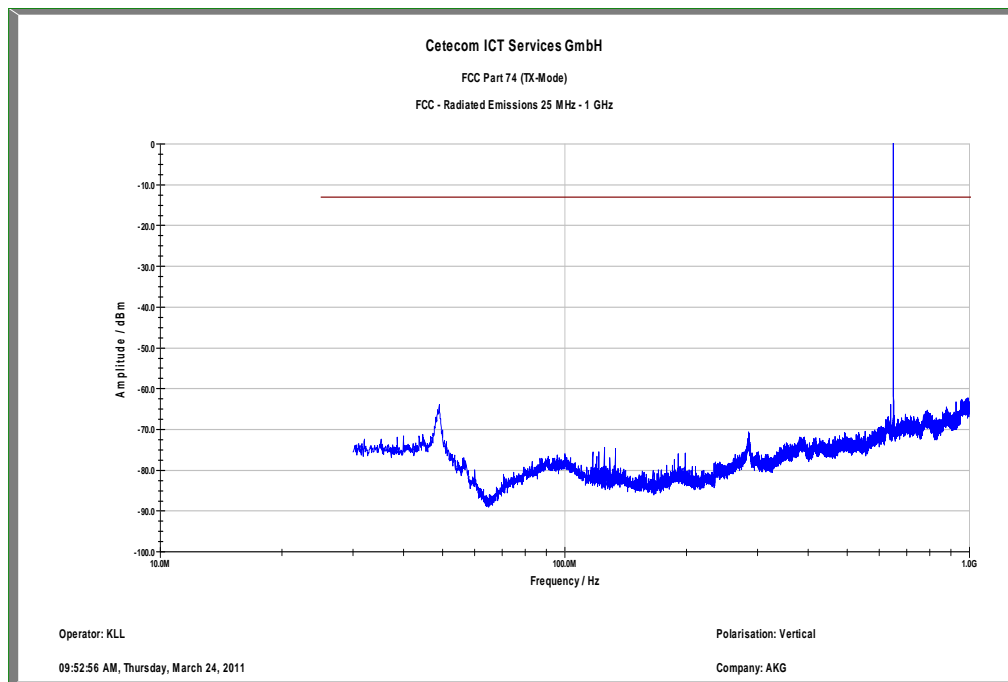

Plot 58: Band I (650.1MHz-680.0MHz) low channel, 1 GHz – 12.75 GHz, antenna vertical

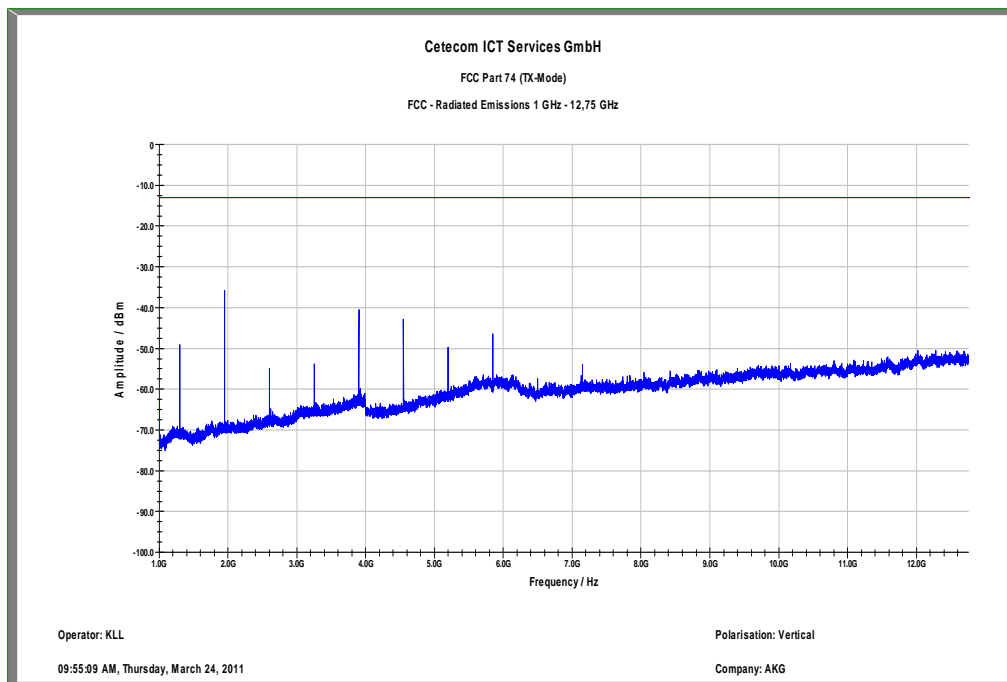

Plot 59: Band I (650.1MHz-680.0MHz) low channel, 30 MHz – 1 GHz, antenna horizontal

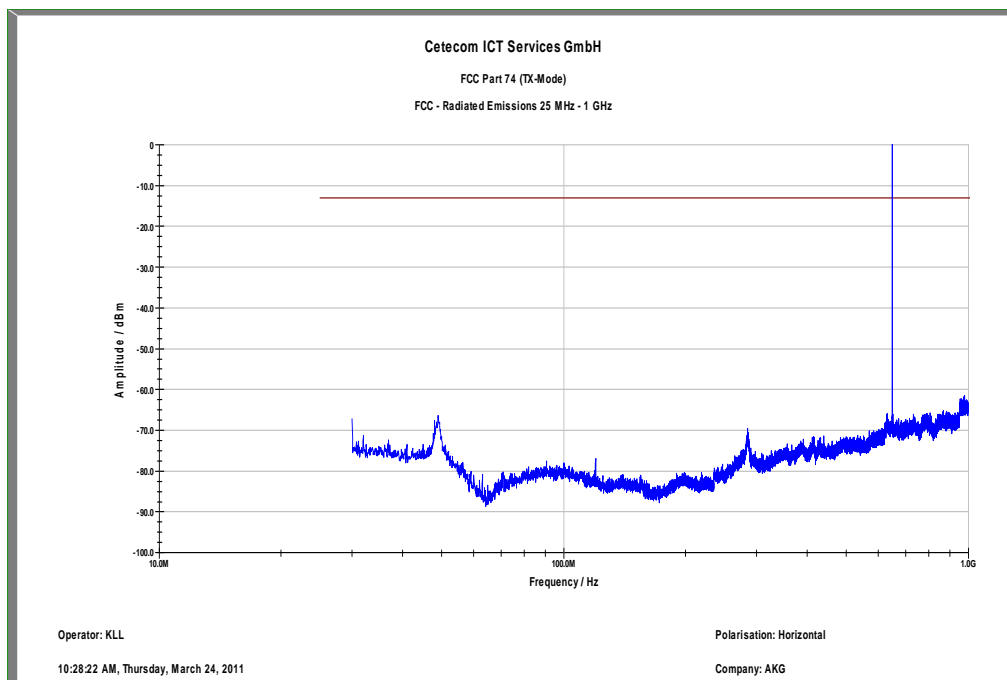

Plot 60: Band I (650.1MHz-680.0MHz) low channel, 1 GHz – 12.75 GHz, antenna horizontal

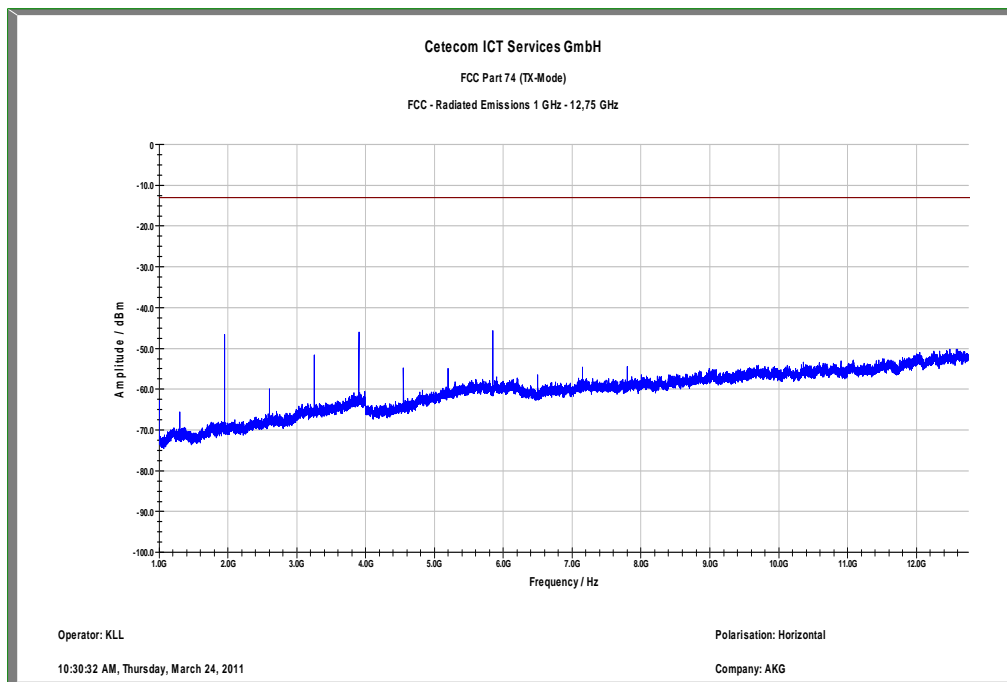

Plot 61: Band I (650.1MHz-680.0MHz) middle channel, <30MHz

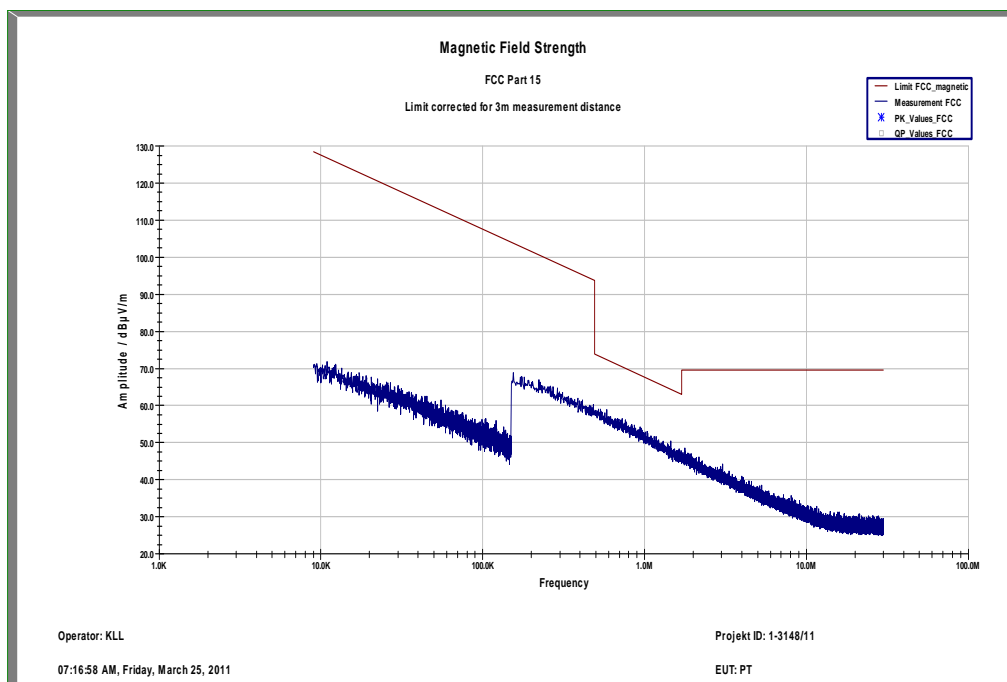

Plot 62: Band I (650.1MHz-680.0MHz) middle channel, 30 MHz – 1 GHz, antenna vertical

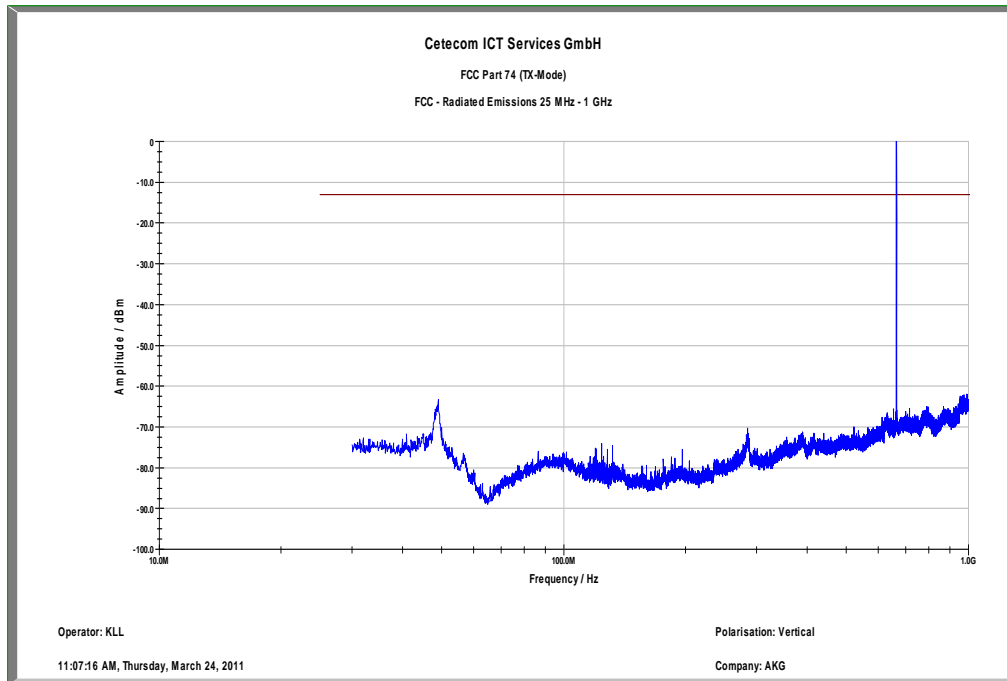

Plot 63: Band I (650.1MHz-680.0MHz) middle channel, 1 GHz – 12.75 GHz, antenna vertical

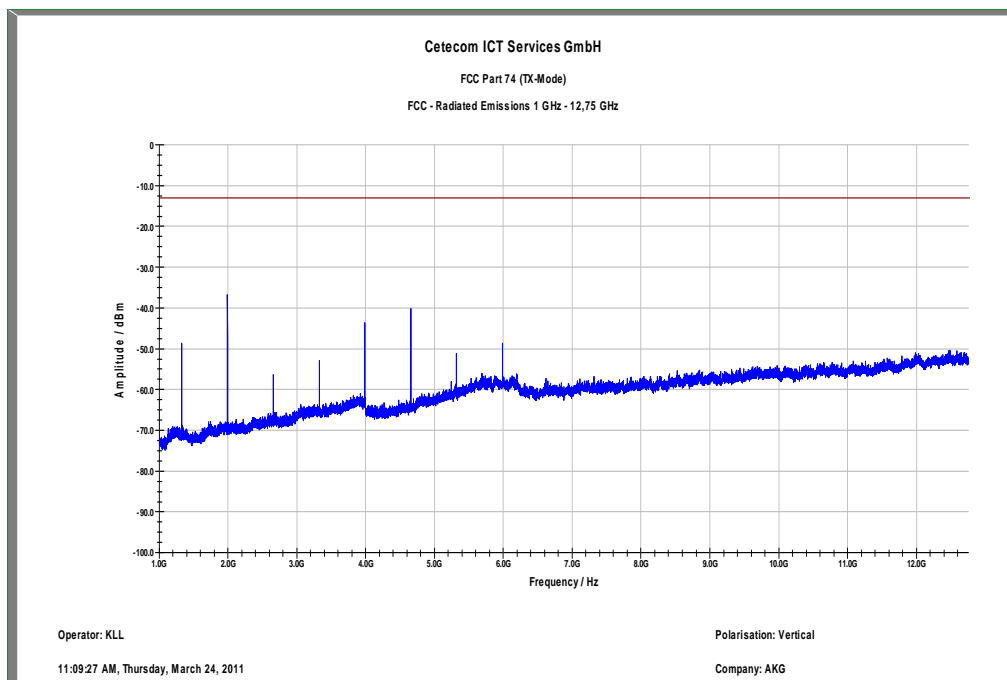

Plot 64: Band I (650.1MHz-680.0MHz) middle channel, 30 MHz – 1 GHz, antenna horizontal

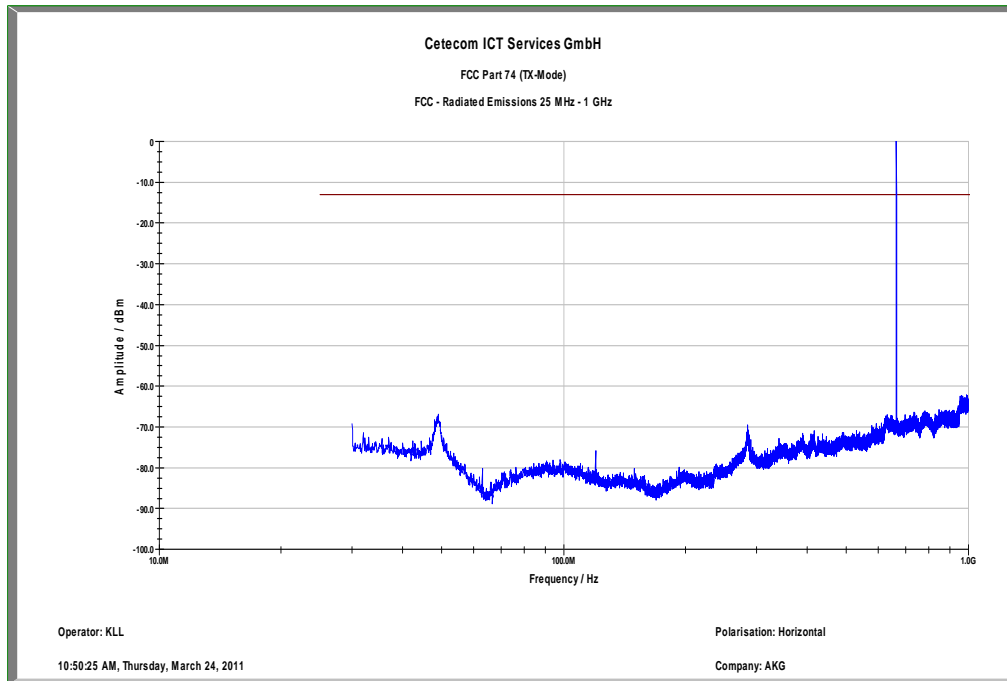

Plot 65: Band I (650.1MHz-680.0MHz) middle channel, 1 GHz – 12.75 GHz, antenna horizontal

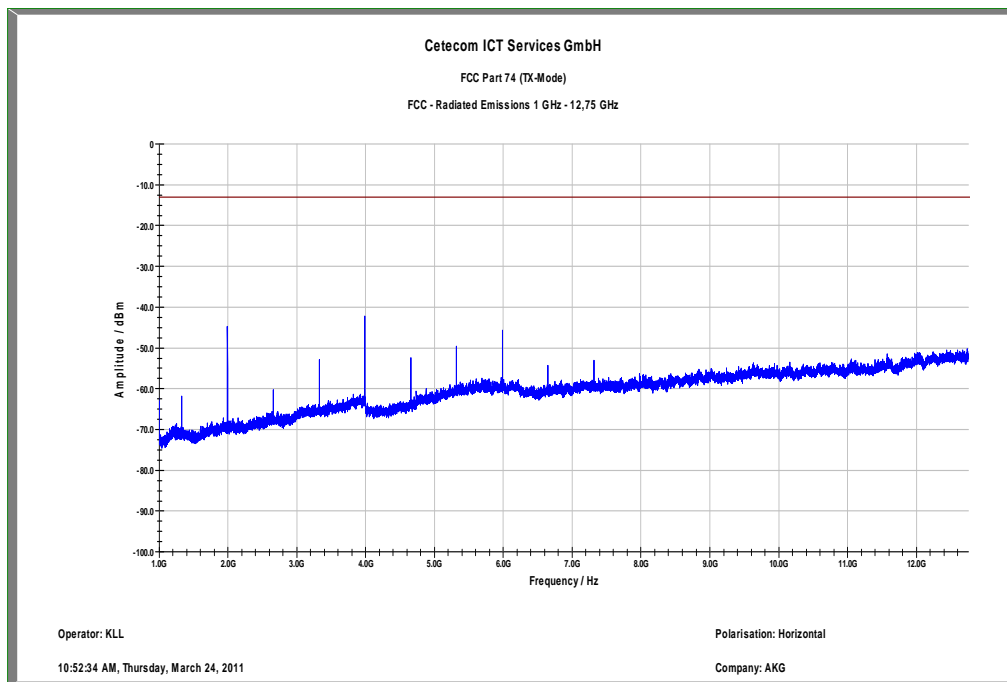

Plot 66: Band I (650.1MHz-680.0MHz) high channel, <30MHz

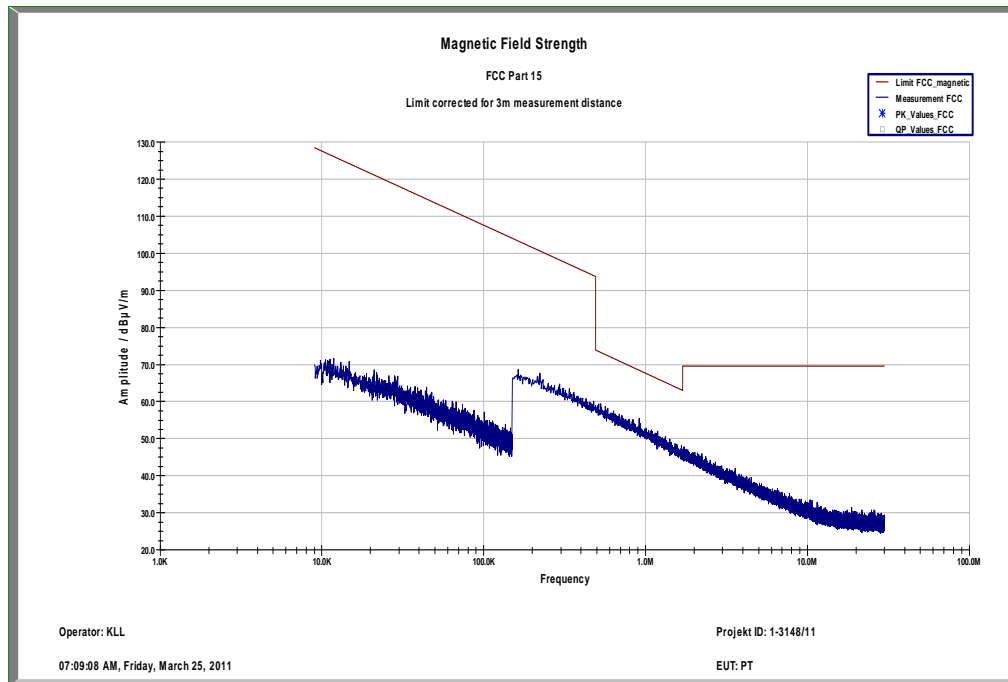

Plot 67: Band I (650.1MHz-680.0MHz) high channel, 30 MHz – 1 GHz, antenna vertical

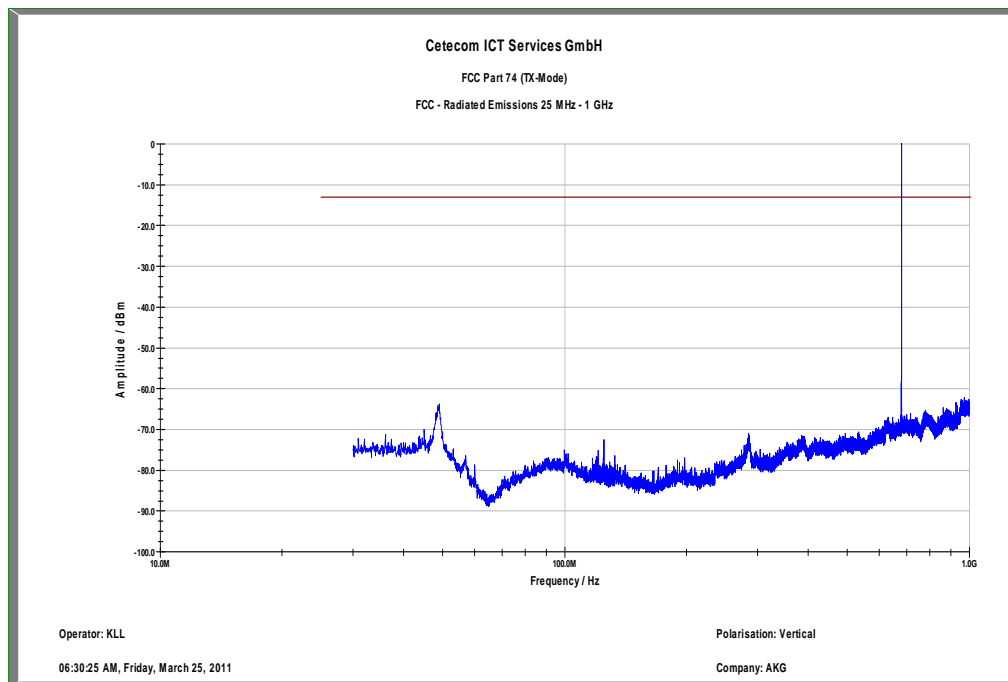

Plot 68: Band I (650.1MHz-680.0MHz) high channel, 1 GHz – 12.75 GHz, antenna vertical

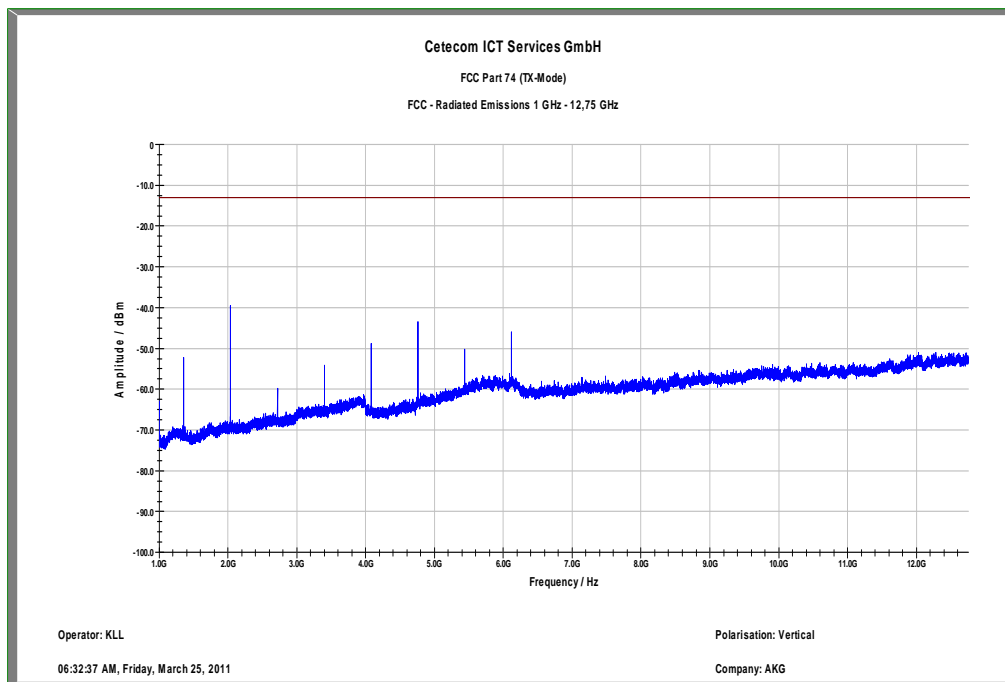

Plot 69: Band I (650.1MHz-680.0MHz) high channel, 30 MHz – 1 GHz, antenna horizontal

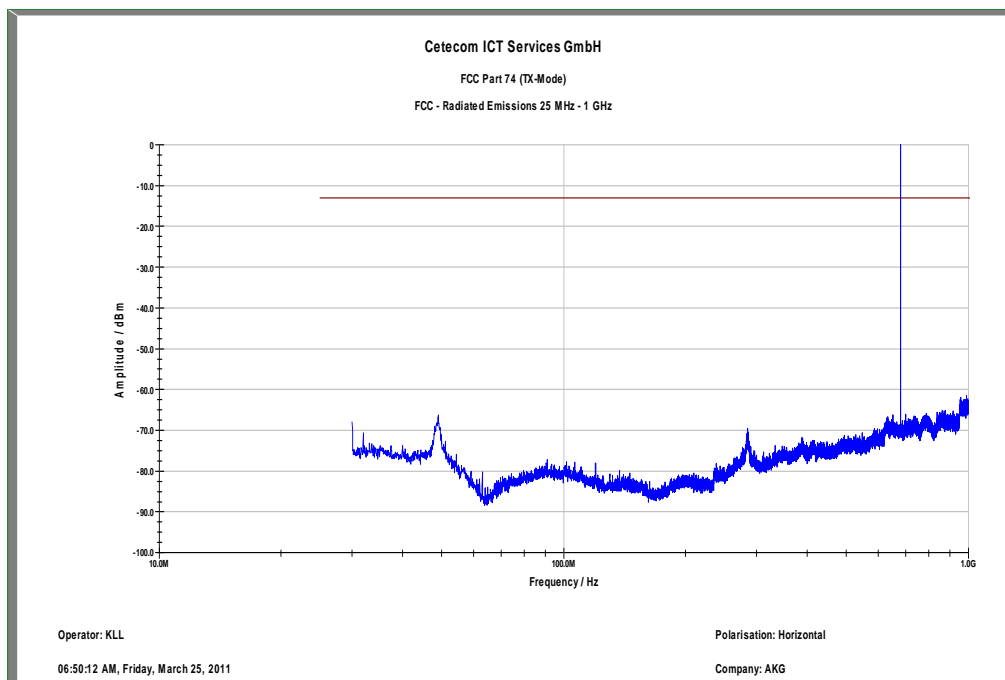



Plot 70: Band I (650.1MHz-680.0MHz) high channel, 1 GHz – 12.75 GHz, antenna horizontal

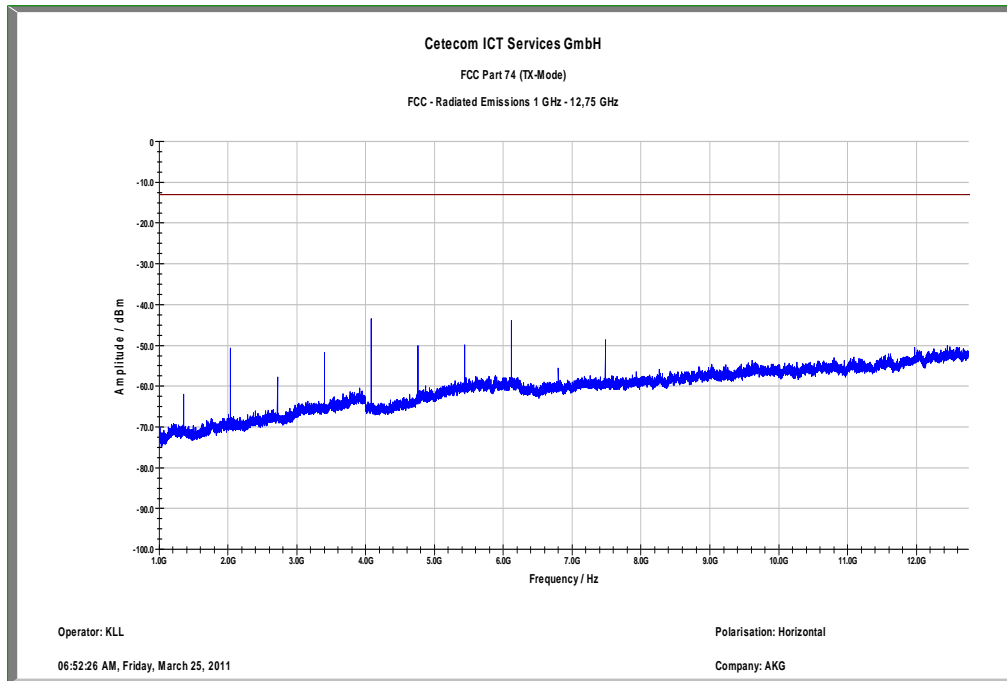

**9.7 Receiver spurious emissions (radiated)**

**Not applicable**

## 10 Test equipment and ancillaries used for tests

Typically, the calibrations of the test apparatus are commissioned to and performed by an accredited calibration laboratory. The calibration intervals are determined in accordance with the DIN EN ISO/IEC 17025. In addition to the external calibrations, the laboratory executes comparison measurements with other calibrated test systems or effective verifications. Weekly chamber inspections and range calibrations are performed. Where possible, rf-generating and signalling equipment as well as measuring receivers and analyzers are connected to an external high-precision 10 MHz reference (GPS-based or rubidium frequency standard).

In order to simplify the identification of the equipment used at some special tests, some items of test equipment and ancillaries can be provided with an identifier or number in the equipment list below (Labor/Item).

| No. | Lab / Item   | Equipment                                      | Type                                 | Manufact.            | Serial No. | INV. No Cetecom | Kind of Calibration | Last Calibration | Next Calibration |
|-----|--------------|--|--------------------------------------|----------------------|------------|-----------------|---------------------|------------------|------------------|
| 1   | n. a.        | Isolating Transformer                          | RT5A                                 | Grundig              | 8041       | 300001626       | g                   |                  |                  |
| 2   | n. a.        | DC power supply, 60Vdc, 50A, 1200 W            | 6032A                                | HP Meßtechnik        | 2818A03450 | 300001040       | Ve                  | 08.01.2009       | 08.01.2012       |
| 3   | n. a.        | Coaxial Attenuator 30dB/500W                   | 8325                                 | Bird                 | 1530       | 300001595       | ev                  |                  |                  |
| 4   | n. a.        | Double-Ridged Waveguide Horn Antenna 1-18.0GHz | 3115                                 | EMCO                 | 8812-3088  | 300001032       | vKI!                | 05.03.2009       | 05.09.2011       |
| 5   | n. a.        | Active Loop Antenna                            | 6502                                 | EMCO                 | 2210       | 300001015       | ne                  |                  |                  |
| 6   | n. a.        | Anechoic chamber                               | FAC 3/5m                             | MWB / TDK            | 87400/02   | 300000996       |                     | 23.03.2009       |                  |
| 7   | Spec.A. 2_2e | System rack for EMI measurement solution       | 85900                                | HP I.V.              | *          | 300000222       | ne                  |                  |                  |
| 8   | 9            | Artificial Mains 9 kHz to 30 MHz               | ESH3-Z5                              | R&S                  | 828576/020 | 300001210       | Ve                  | 06.01.2010       | 06.01.2012       |
| 9   | n. a.        | Relais Matrix                                  | 3488A                                | HP Meßtechnik        | 2719A15013 | 300001156       | ne                  |                  |                  |
| 10  | n. a.        | Relais Matrix                                  | PSU                                  | R&S                  | 890167/024 | 300001168       | ne                  |                  |                  |
| 11  | n. a.        | Isolating Transformer                          | RT5A                                 | Grundig              | 9242       | 300001263       | ne                  |                  |                  |
| 12  | n. a.        | Three-Way Power Splitter, 50 Ohm               | 11850C                               | HP Meßtechnik        |            | 300000997       | ne                  |                  |                  |
| 13  | n. a.        | Switch / Control Unit                          | 3488A                                | HP                   | 2605e08770 | 300001443       | ne                  |                  |                  |
| 14  | n. a.        | Amplifier                                      | js42-00502650-28-5a                  | Parzich GMBH         | 928979     | 300003143       | ne                  |                  |                  |
| 15  | n. a.        | Band Reject filter                             | WRCG1855/1910-1835/1925-40/8SS       | Wainwright           | 7          | 300003350       | ev                  |                  |                  |
| 16  | n. a.        | Band Reject filter                             | WRCG2400/2483-2375/2505-50/10SS      | Wainwright           | 11         | 300003351       | ev                  |                  |                  |
| 17  | n. a.        | TILE-Software Emission                         | Quantum Change, Modell TILE-ICS/FULL | EMCO                 | none       | 300003451       | ne                  |                  |                  |
| 18  | n. a.        | Highpass Filter                                | WHKX2.9/18G-12SS                     | Wainwright           | 1          | 300003492       | ev                  |                  |                  |
| 19  | n. a.        | Highpass Filter                                | WHK1.1/15G-10SS                      | Wainwright           | 3          | 300003255       | ev                  |                  |                  |
| 20  | n. a.        | Highpass Filter                                | WHKX7.0/18G-8SS                      | Wainwright           | 18         | 300003789       | ne                  |                  |                  |
| 21  | n. a.        | PSA Spectrum Analyzer 3 Hz - 26.5 GHz          | E4440A                               | Agilent Technologies | MY48250080 | 300003812       | k                   | 08.09.2010       | 08.09.2012       |
| 22  | n. a.        | MXG Microwave Analog Signal Generator          | N5183A                               | Agilent Technologies | MY47420220 | 300003813       | k                   | 13.09.2010       | 13.09.2012       |
| 23  | n. a.        | RF Filter Section 9kHz - 1GHz                  | N9039A                               | Agilent Technologies | MY48260003 | 300003825       | vKI!                | 08.09.2010       | 08.09.2012       |
| 24  | n. a.        | TRILOG   | VULB9163                             | Schwarzbeck          | 371        | 300003854       | vKI!                | 17.12.2008       | 17.12.2011       |

|    |       |   |         |          |             |           |      |            |            |
|----|-------|---|---------|----------|-------------|-----------|------|------------|------------|
|    |       | Broadband Test-Antenna 30 MHz - 3 GHz         |         |          |             |           |      |            |            |
| 25 | 2     | Radiocom. Analyzer                            | CMTA 84 | R&S      | 894199/012  | 300001176 | vKI! | 20.01.2010 | 20.01.2012 |
| 26 | n. a. | DC Power Supply 0 – 32V                       | 1108-32 | Heiden   | 001802      | 300001383 | Ve   | 23.06.2010 | 23.06.2013 |
| 27 | n. a. | Audio Analyzer 2Hz - 300 kHz                  | UPD     | R&S      | 841074/009  | 300001236 | k    | 08.01.2010 | 08.01.2012 |
| 28 | n. a. | Signal Analyzer 20Hz- 26,5GHz-150 to + 30 DBM | FSiQ26  | R&S      | 835111/0004 | 300002678 | Ve   | 04.11.2010 | 04.11.2012 |
| 29 | n. a. | Temperature Test Chamber                      | T-40/50 | CTS GmbH | 064023      | 300003540 | vKI! | 04.06.2009 | 04.06.2011 |

Agenda: Kind of Calibration

k calibration / calibrated  
 ne not required (k, ev, izw, zw not required)  
 ev periodic self verification  
 Ve long-term stability recognized  
 vki! Attention: extended calibration interval  
 NK! Attention: not calibrated

EK limited calibration  
 zw cyclical maintenance (external cyclical maintenance)  
 izw internal cyclical maintenance  
 g blocked for accredited testing  
 \*) next calibration ordered / currently in progress

**Annex A Photographs of the test setup**

Photo documentation:

Photo 1:

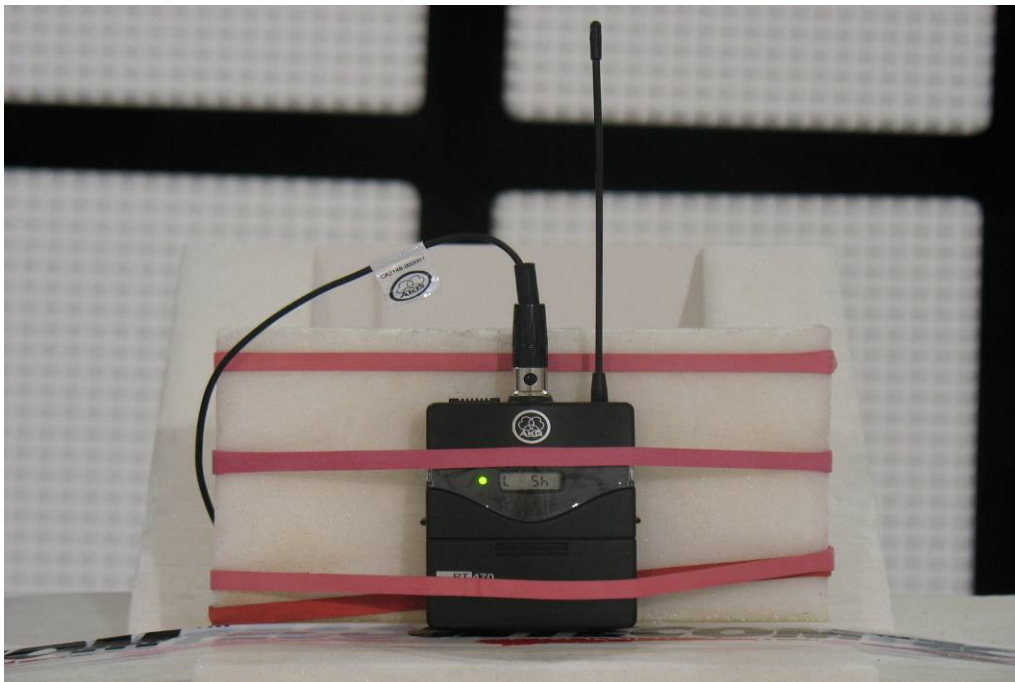

Photo 2:



Photo 3:



Photo 4:



**Annex B External photographs of the EUT**

Photo documentation:

Photo 1:



Photo 2:



Photo 3:



Photo 4:





Photo 5:

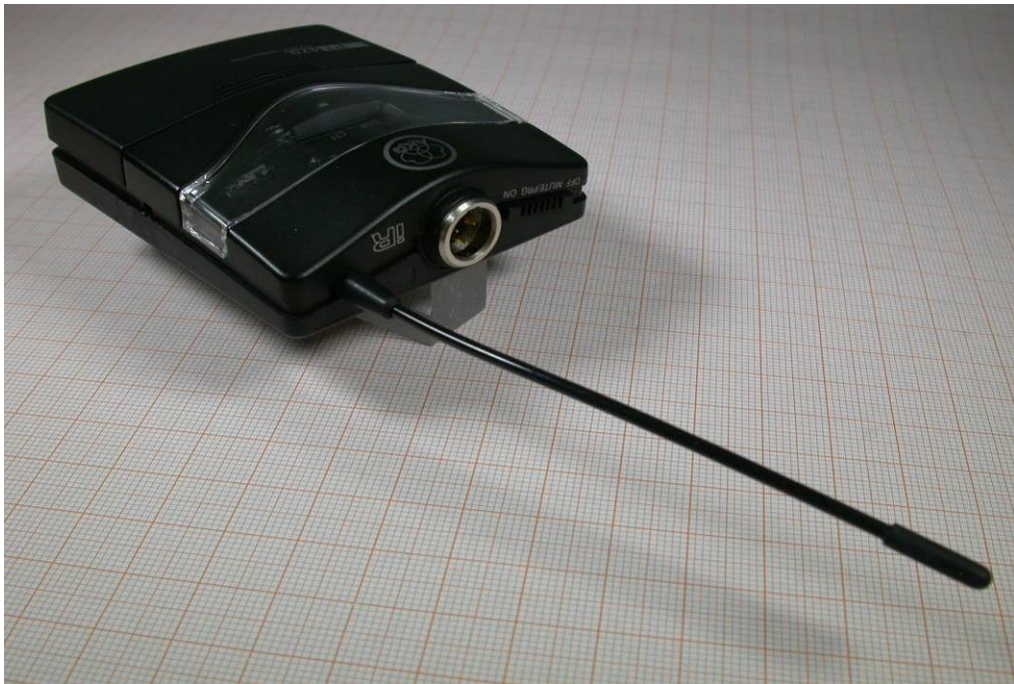

Photo 6:



Photo 7:



**Annex C Internal photographs of the EUT**

Photo documentation:

Photo 1:



Photo 2:

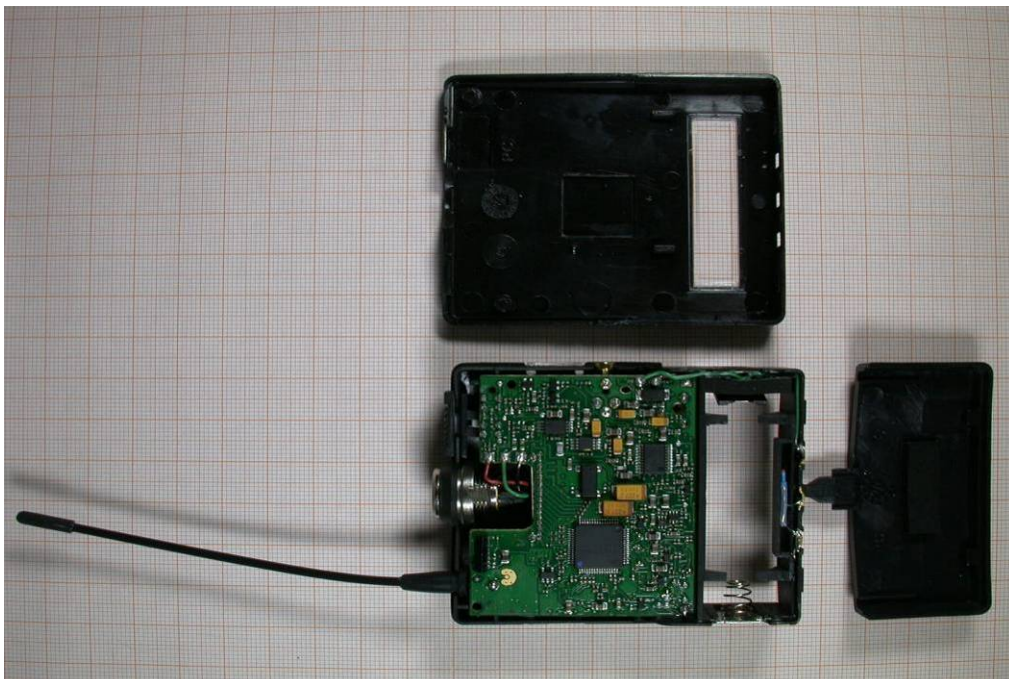

Photo 3:

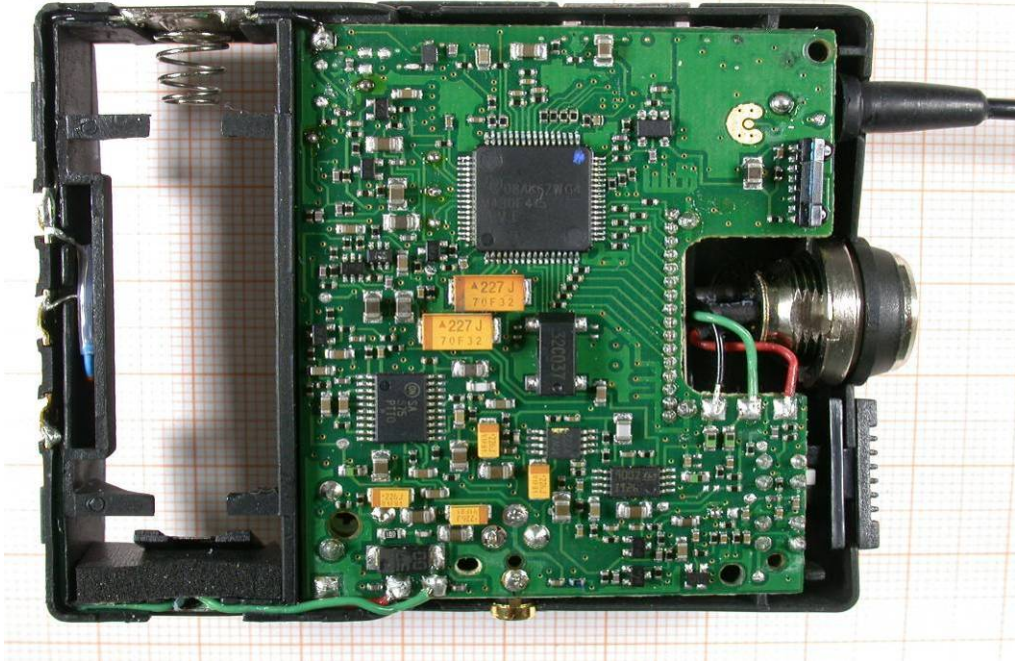

Photo 4:

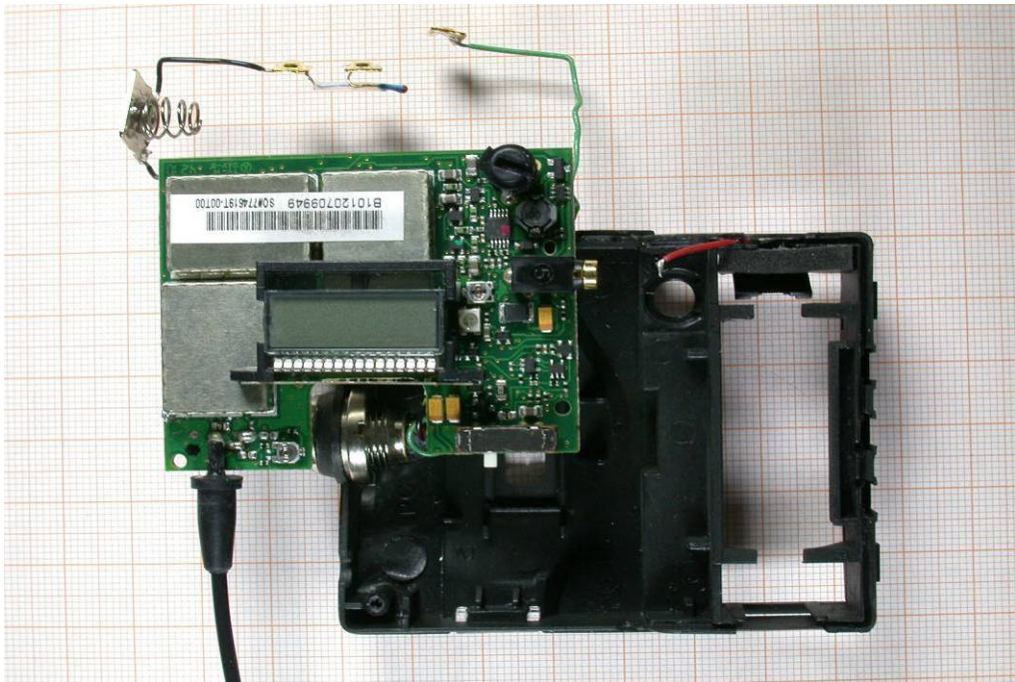

Photo 5:

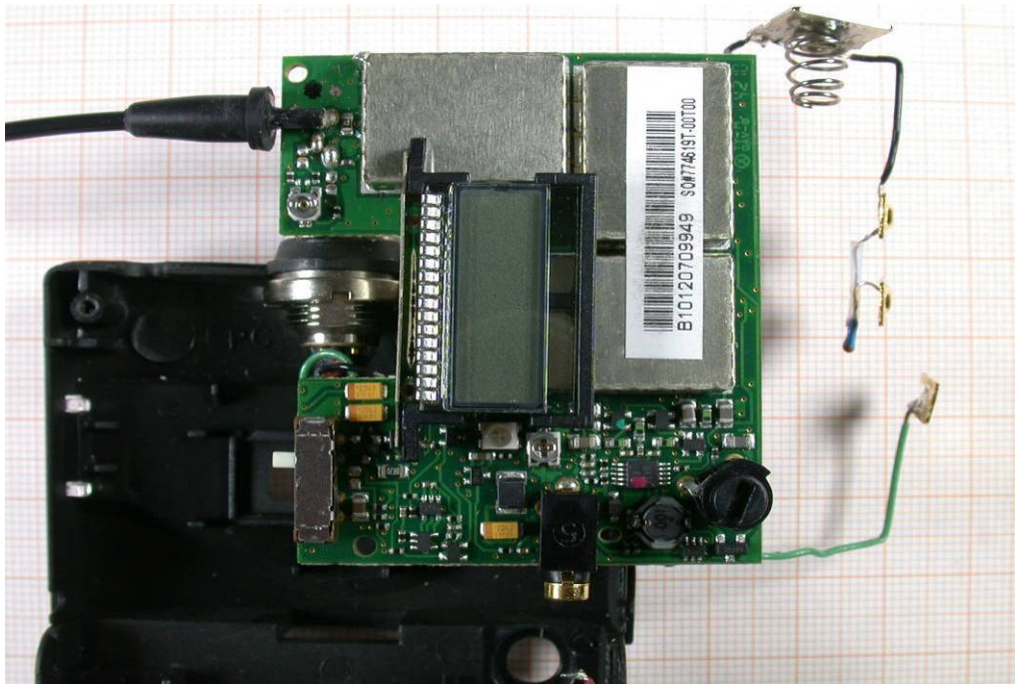

Photo 6:

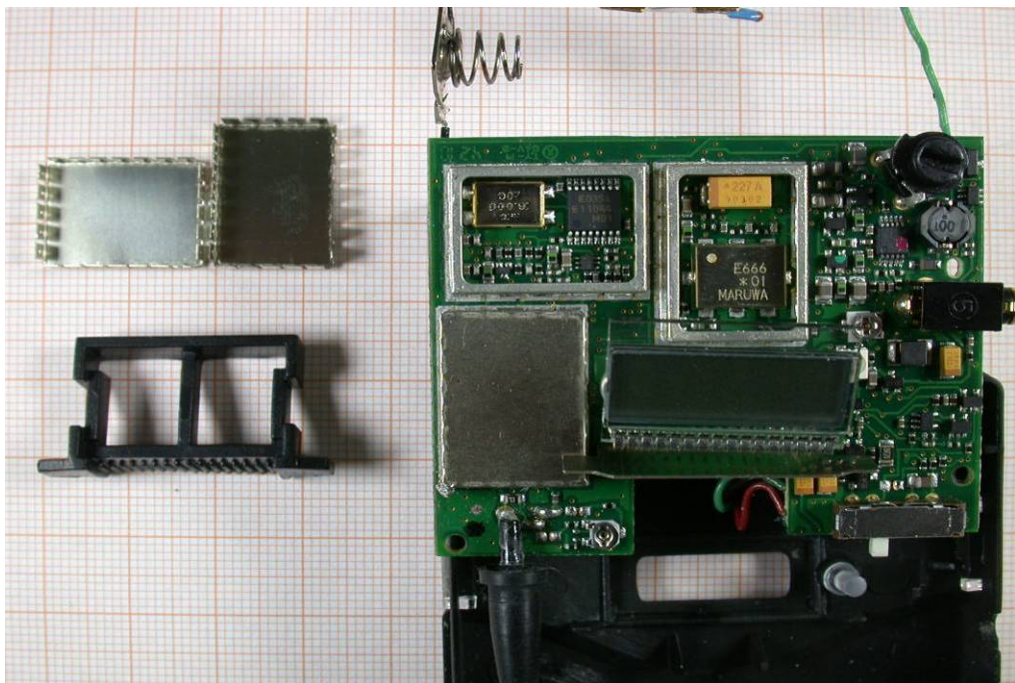

Photo 7:

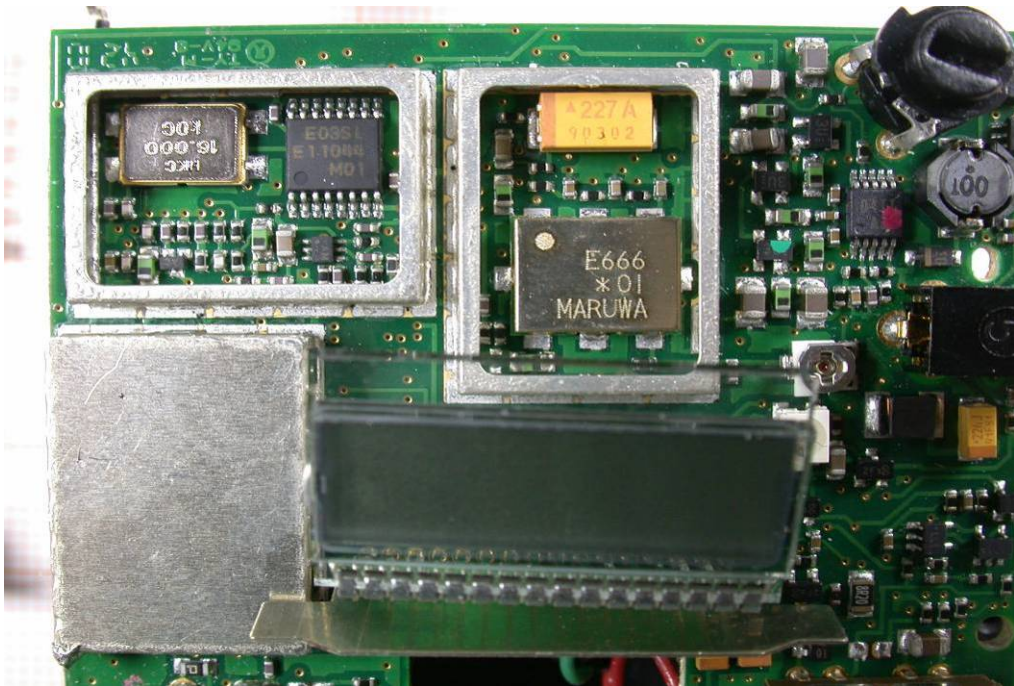

Photo 8:



Photo 9:

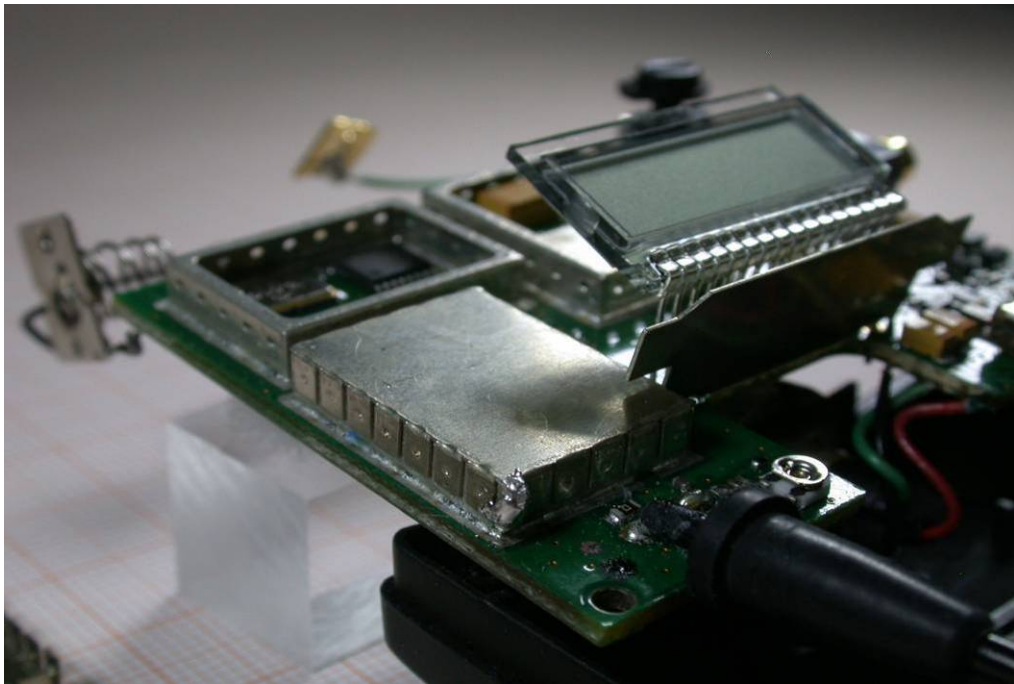

Photo 10:

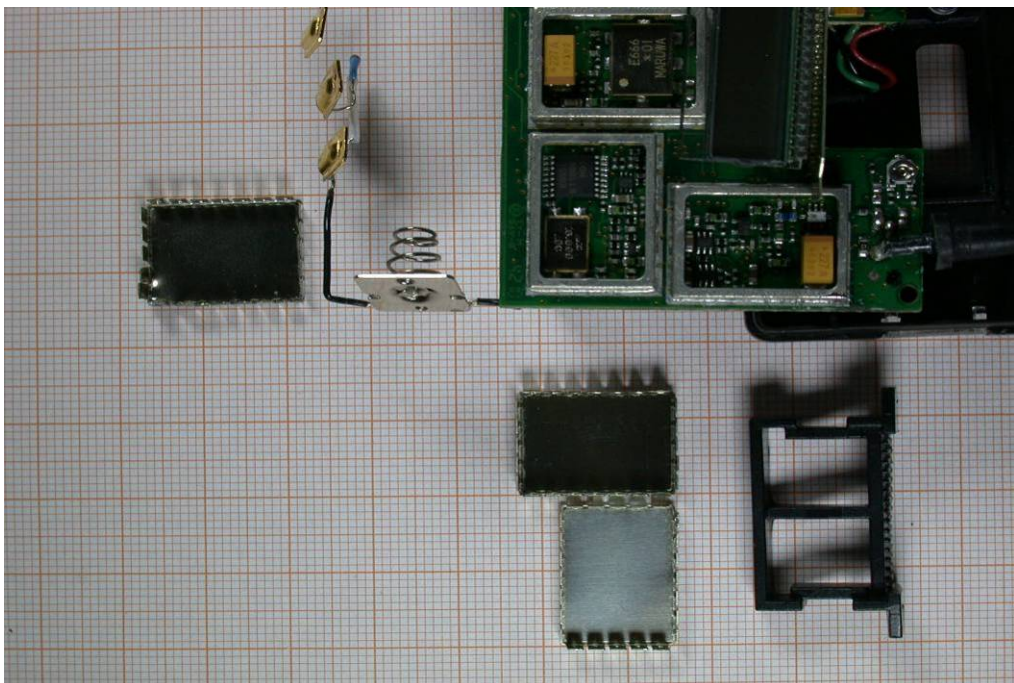
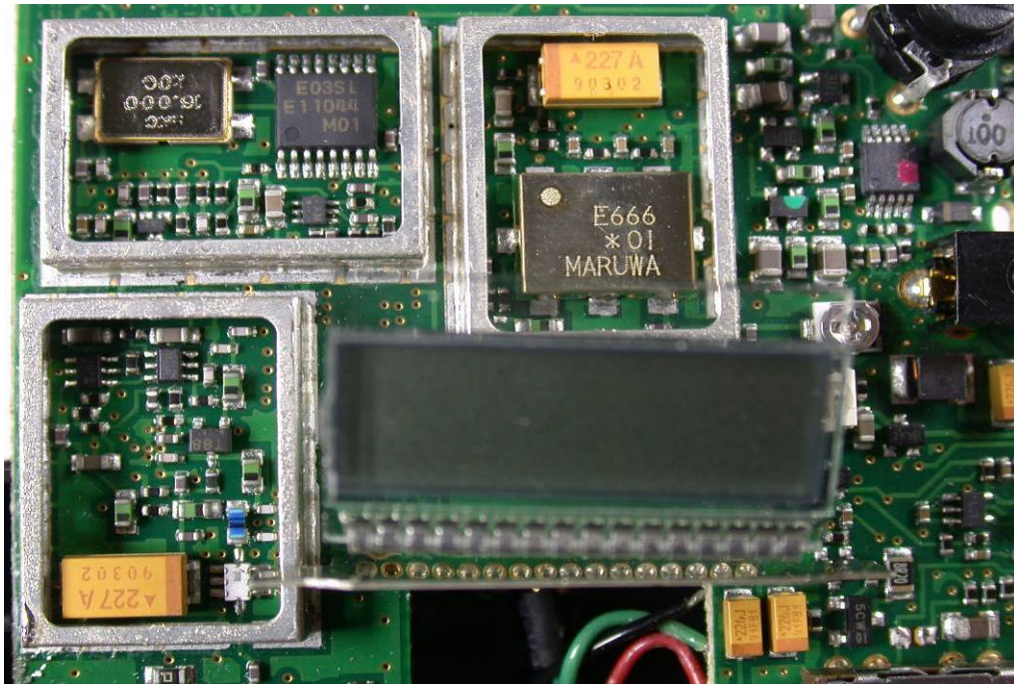

Photo 11:





**Annex D Document history**

| Version | Applied changes | Date of release |
|---------|-----------------|-----------------|
| 1.0     | Initial release | 2011-06-17      |

**Annex E Further information****Glossary**

|          |   |                                  |
|----------|---|----------------------------------|
| DUT      | - | Device under Test                |
| EMC      | - | Electromagnetic Compatibility    |
| EUT      | - | Equipment under Test             |
| FCC      | - | Federal Communication Commission |
| FCC ID   | - | Company Identifier at FCC        |
| HW       | - | Hardware                         |
| IC       | - | Industry Canada                  |
| Inv. No. | - | Inventory number                 |
| N/A      | - | not applicable                   |
| S/N      | - | Serial Number                    |
| SW       | - | Software                         |