

Measurement Data

Crest Factor : 8
Tissue Temp. : 20.20 °C
Ambient Temp. : 21.10 °C
Area Scan : 6x6x1 : Measurement x=12mm, y=12mm, z=4mm
Zoom Scan : 7x7x7 : Measurement x=5mm, y=5mm, z=5mm
Power Drift-Start : 0.482 W/kg
Power Drift-Finish: 0.508 W/kg
Power Drift (%) : 2.904

DUT Position : 15° Tilt
Channel : 512

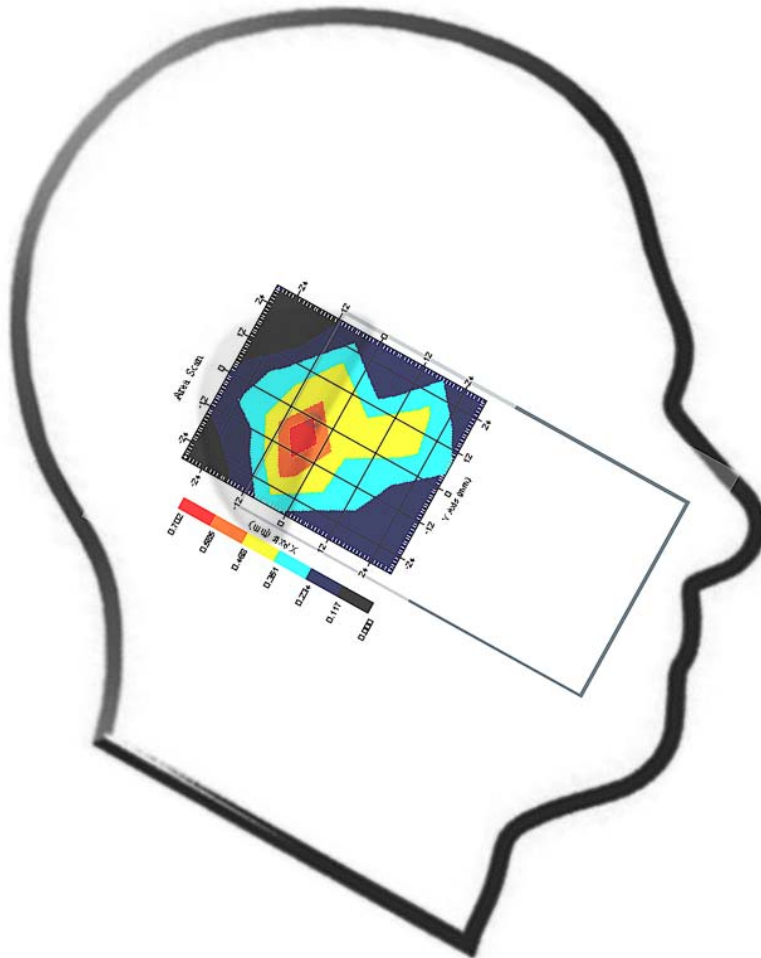

1 gram SAR value : 0.625 W/kg
10 gram SAR value : 0.534 W/kg
Area Scan Peak SAR : 0.687 W/kg
Zoom Scan Peak SAR : 1.352 W/kg

This is previous page plot (zoom in)

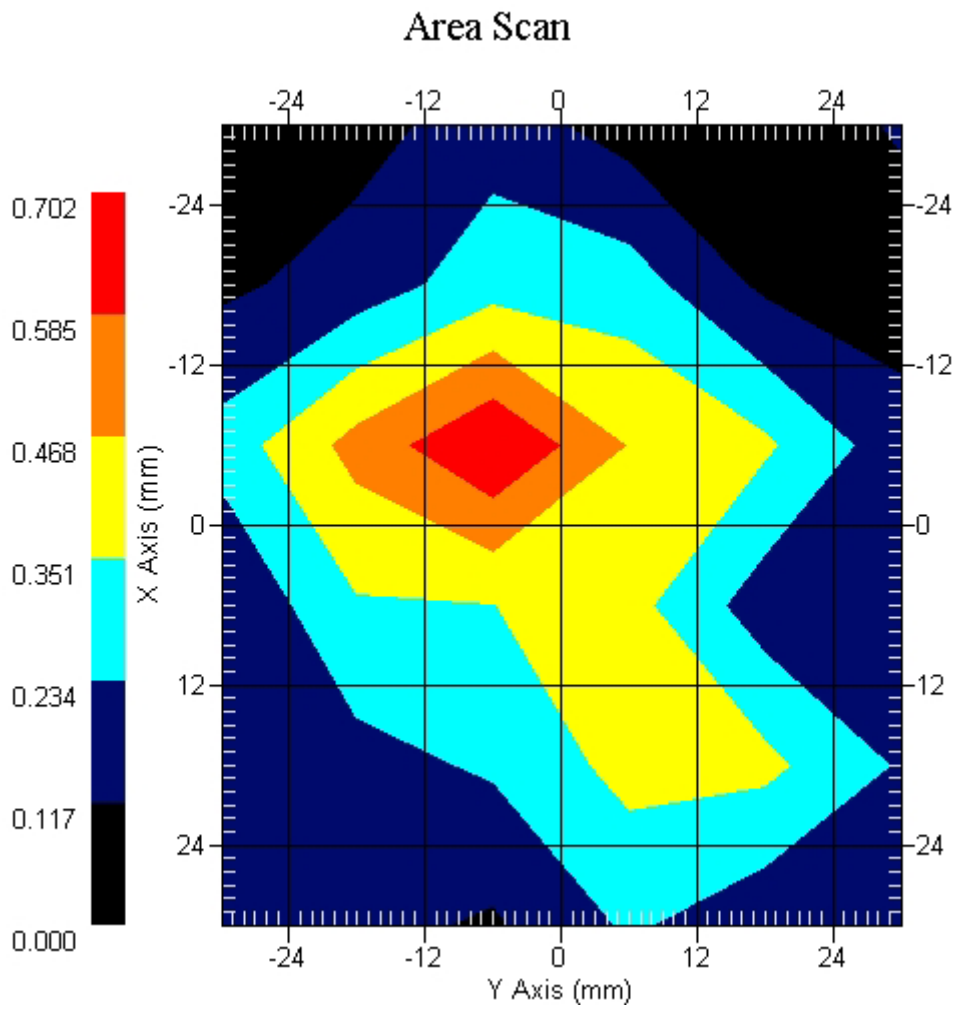

Measurement Data

Crest Factor : 8
Tissue Temp. : 20.20 °C
Ambient Temp. : 21.10 °C
Area Scan : 6x6x1 : Measurement x=12mm, y=12mm, z=4mm
Zoom Scan : 7x7x7 : Measurement x=5mm, y=5mm, z=5mm
Power Drift-Start : 0.345 W/kg
Power Drift-Finish: 0.349 W/kg
Power Drift (%) : 1.159

DUT Position : 15° Tilt
Channel : 661

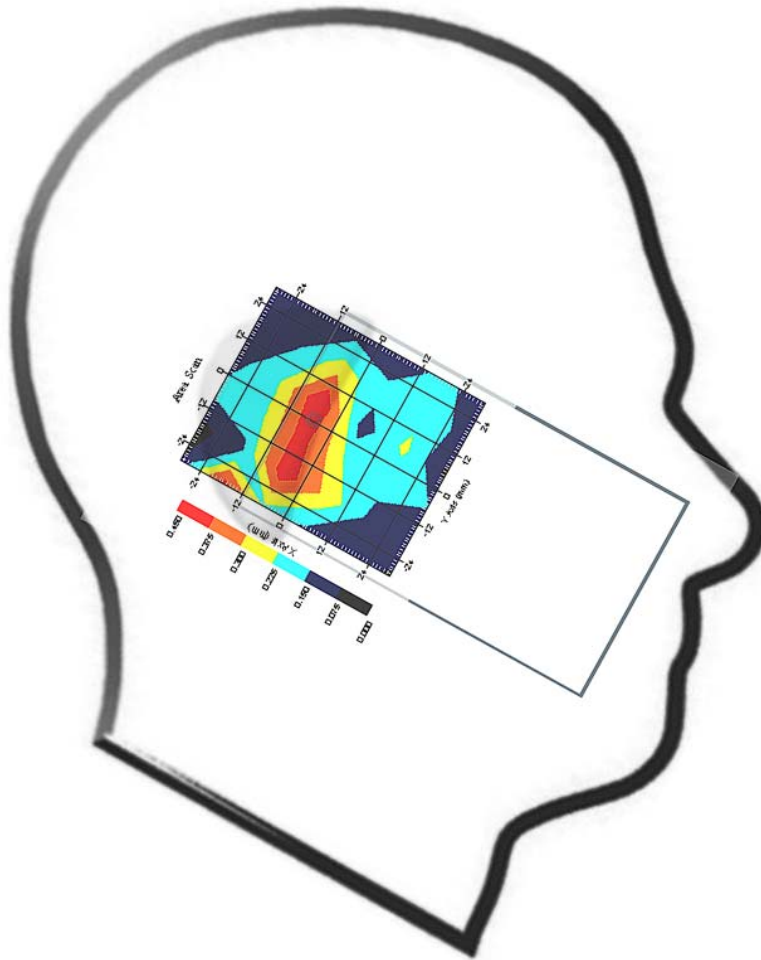

1 gram SAR value : 0.414 W/kg
10 gram SAR value : 0.362 W/kg
Area Scan Peak SAR : 0.450 W/kg
Zoom Scan Peak SAR : 0.891 W/kg

This is previous page plot (zoom in)

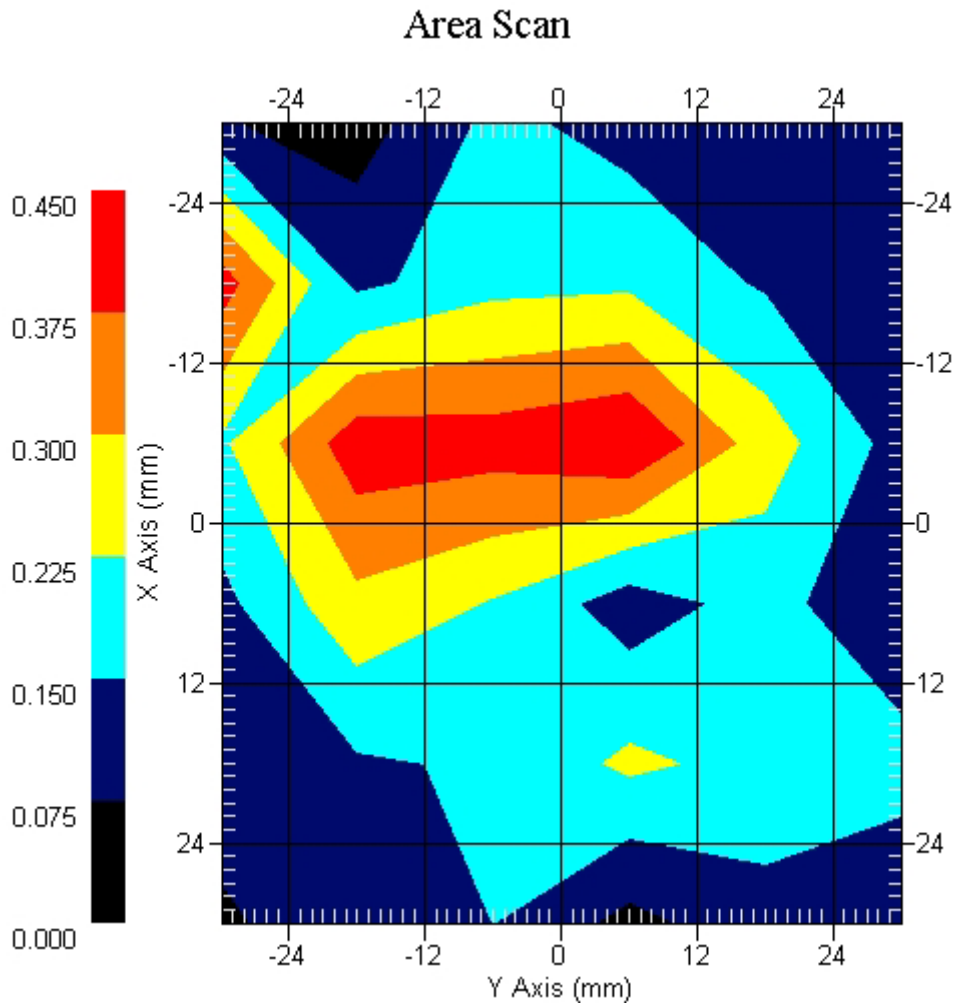

Measurement Data

Crest Factor : 8
Tissue Temp. : 20.20 °C
Ambient Temp. : 21.10 °C
Area Scan : 6x6x1 : Measurement x=12mm, y=12mm, z=4mm
Zoom Scan : 7x7x7 : Measurement x=5mm, y=5mm, z=5mm
Power Drift-Start : 0.261 W/kg
Power Drift-Finish: 0.266 W/kg
Power Drift (%) : 1.532

DUT Position : 15° Tilt
Channel : 810

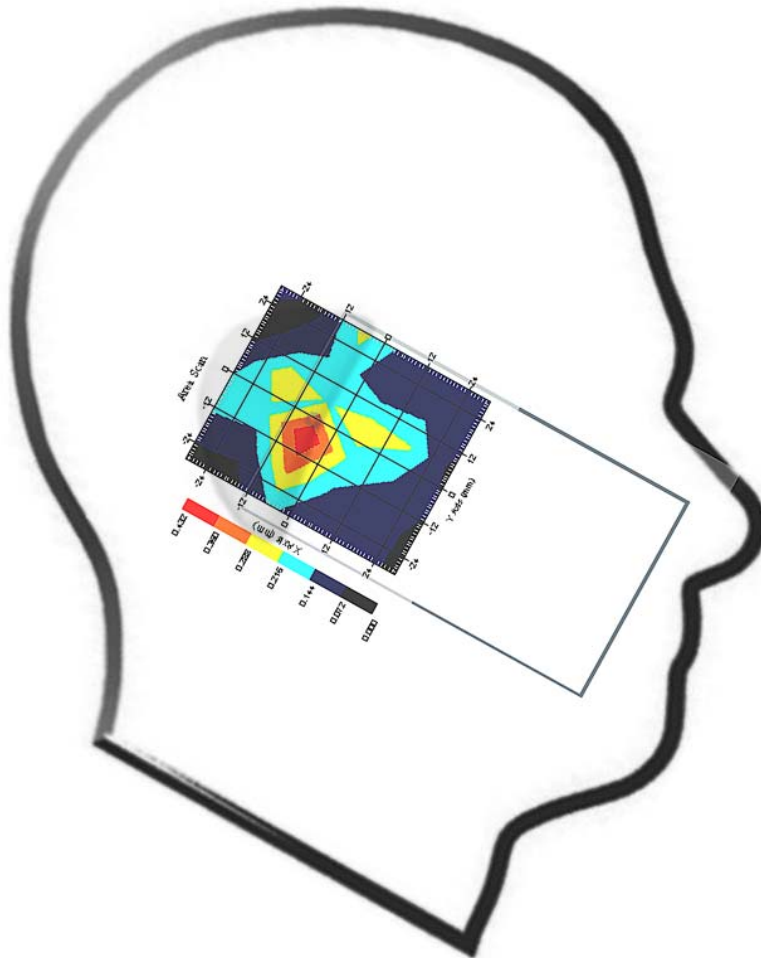

1 gram SAR value : 0.402 W/kg
10 gram SAR value : 0.356 W/kg
Area Scan Peak SAR : 0.430 W/kg
Zoom Scan Peak SAR : 0.885 W/kg

This is previous page plot (zoom in)

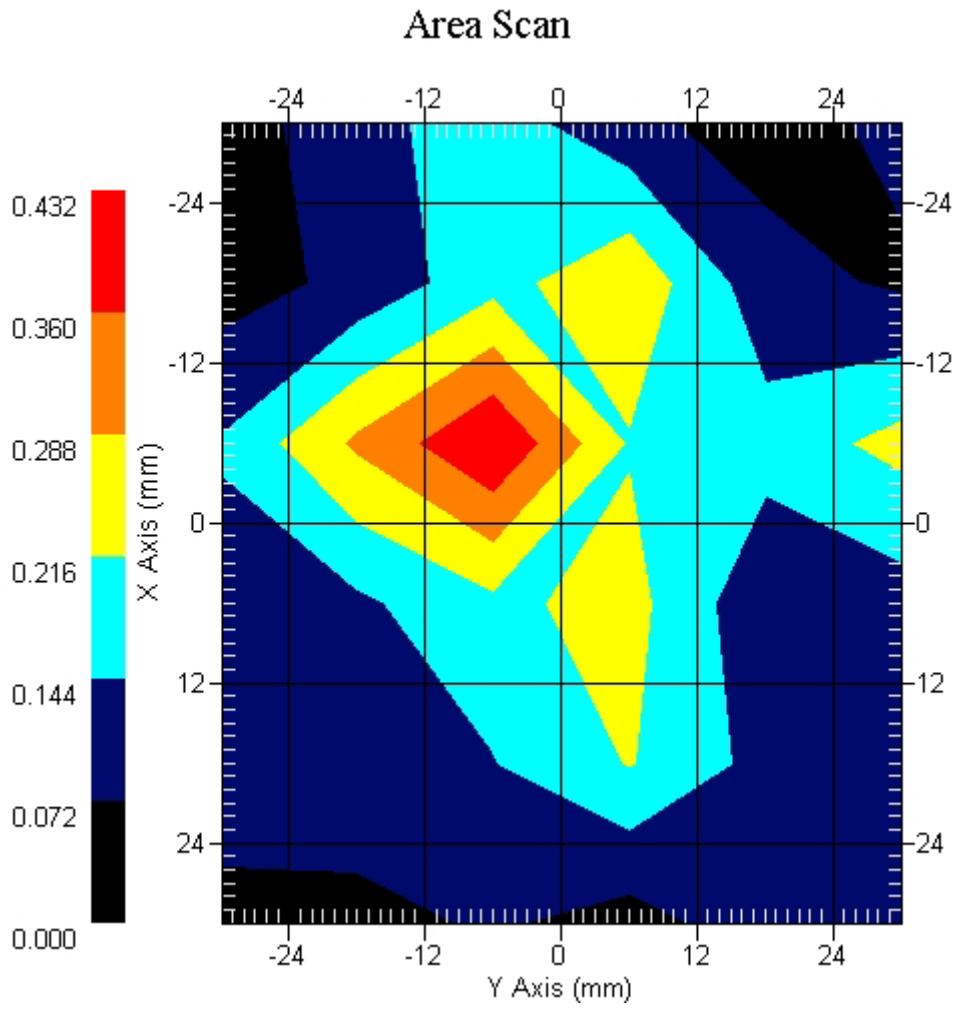

ALSAS-10U VER 2.3.2 APREL Laboratories SAR Test Report

Report Date : 19-Feb-2008
Measurement Date : 19-Feb-2008

Product Data

Device Name : Mobile Phone
Type : Std Form Cell Phone
Model : B8
Frequency : 1900.00 MHz
Max. Transmit Pwr : 1 W
Drift Time : 0 min(s)
Length : 117.8 mm
Width : 67.9 mm
Depth : 15.8 mm
Antenna Type : Internal

Phantom Data

Type : Uni-Phantom
Size (mm) : 280 x 280 x 200
Location : Center

Tissue Data

Type : BODY
Serial No. : 324-B
Frequency : 1900.00 MHz
Last Calib. Date : 19-Feb-2007
Temperature : 20.20 °C
Ambient Temp. : 21.10 °C
Humidity : 50.00 RH%
Epsilon : 54.14 F/m
Sigma : 1.53 S/m
Density : 1000.00 kg/cu. m

Probe Data

Name : Probe 264
Model : E020
Type : E-Field Triangle
Serial No. : 264
Last Calib. Date : 21-Aug-2007
Frequency : 1900.00 MHz
Duty Cycle Factor: 8
Conversion Factor: 5.5
Probe Sensitivity: 1.20 1.20 1.20 $\mu\text{V}/(\text{V}/\text{m})^2$
Compression Point: 95.00 mV
Offset : 1.56 mm

Measurement Data

Crest Factor : 8
 Tissue Temp. : 20.20 °C
 Ambient Temp. : 21.10 °C
 Area Scan : 6x6x1 : Measurement x=12mm, y=12mm, z=4mm
 Zoom Scan : 7x7x7 : Measurement x=5mm, y=5mm, z=5mm
 Power Drift-Start : 0.400 W/kg
 Power Drift-Finish: 0.400 W/kg
 Power Drift (%) : -0.044

DUT Position : Touch
 Channel : 512

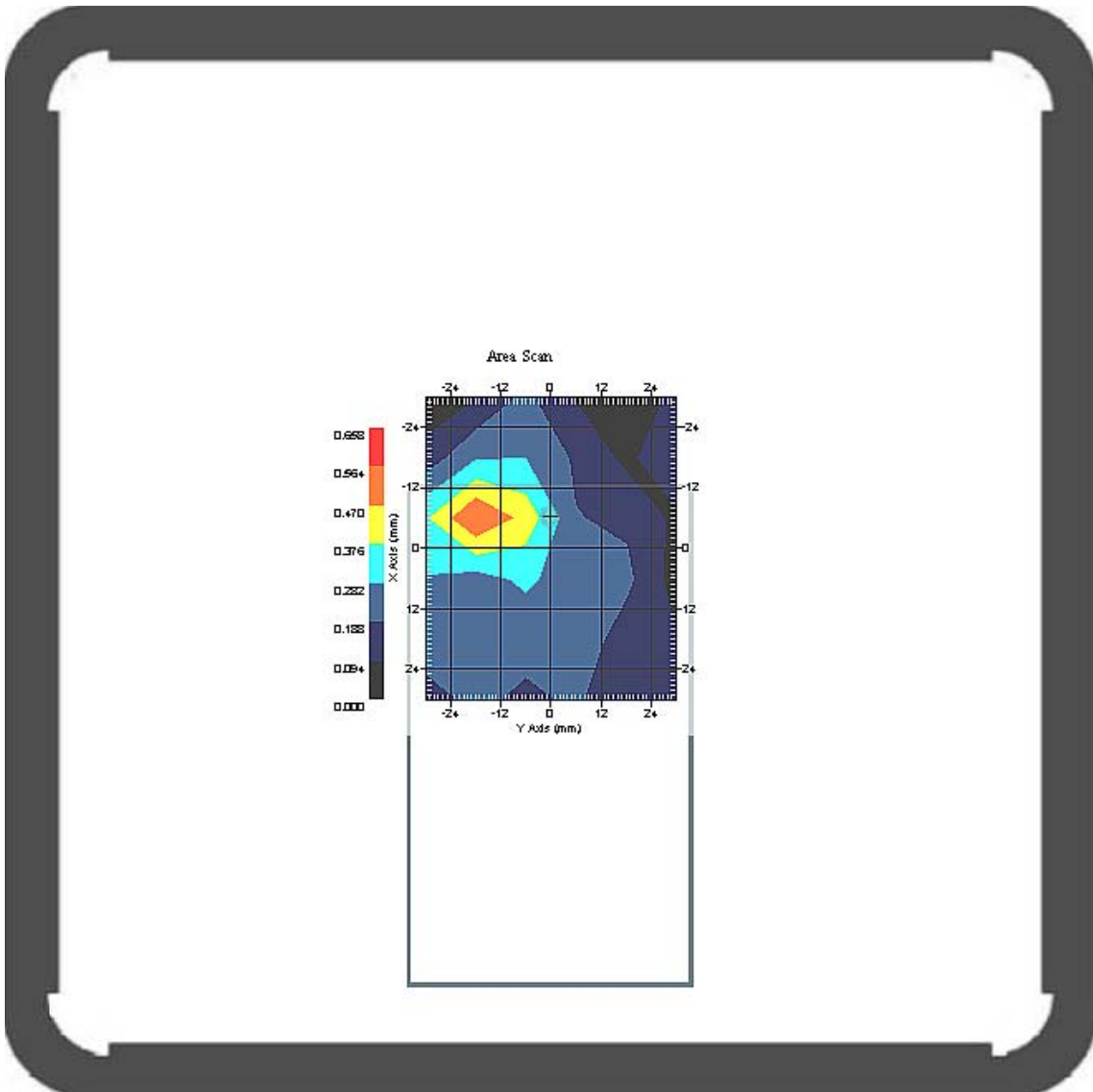

1 gram SAR value : 0.462 W/kg
 10 gram SAR value : 0.267 W/kg
 Area Scan Peak SAR : 0.565 W/kg
 Zoom Scan Peak SAR : 1.080 W/kg

This is previous page plot (zoom in)

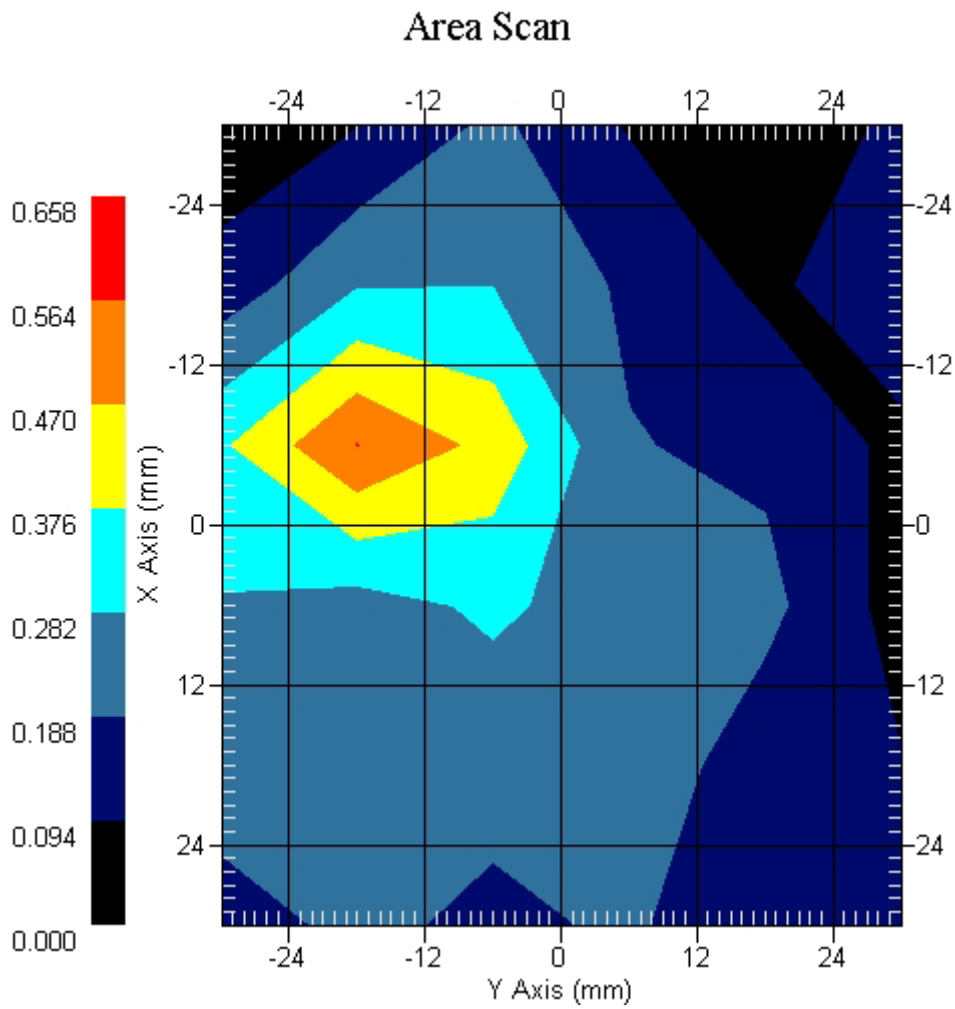

Measurement Data

Crest Factor : 8
 Tissue Temp. : 20.20 °C
 Ambient Temp. : 21.10 °C
 Area Scan : 6x6x1 : Measurement x=12mm, y=12mm, z=4mm
 Zoom Scan : 7x7x7 : Measurement x=5mm, y=5mm, z=5mm
 Power Drift-Start : 0.191 W/kg
 Power Drift-Finish: 0.196 W/kg
 Power Drift (%) : 2.617

DUT Position : Touch
 Channel : 661

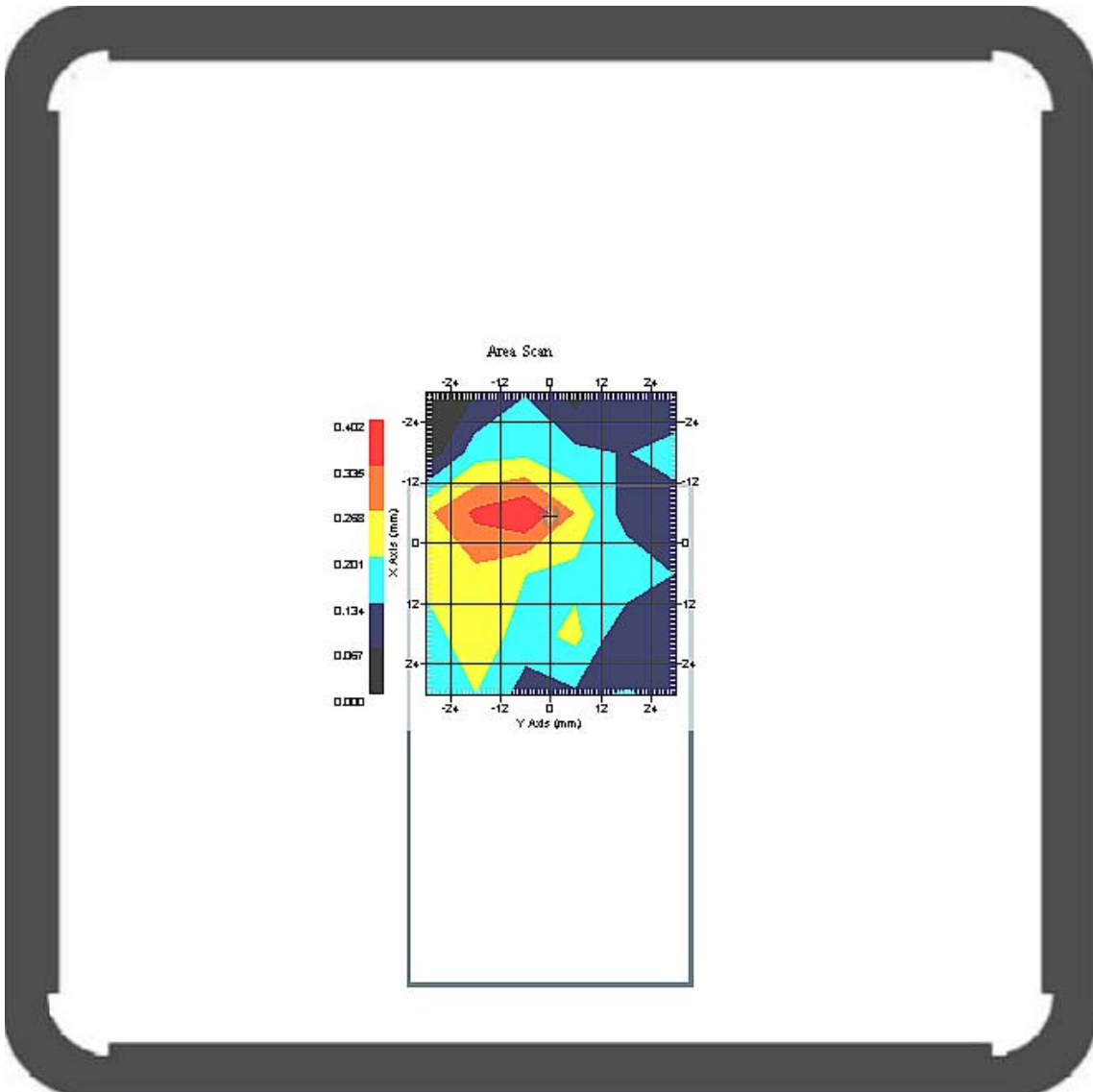

1 gram SAR value : 0.365 W/kg
 10 gram SAR value : 0.287 W/kg
 Area Scan Peak SAR : 0.400 W/kg
 Zoom Scan Peak SAR : 0.690 W/kg

This is previous page plot (zoom in)

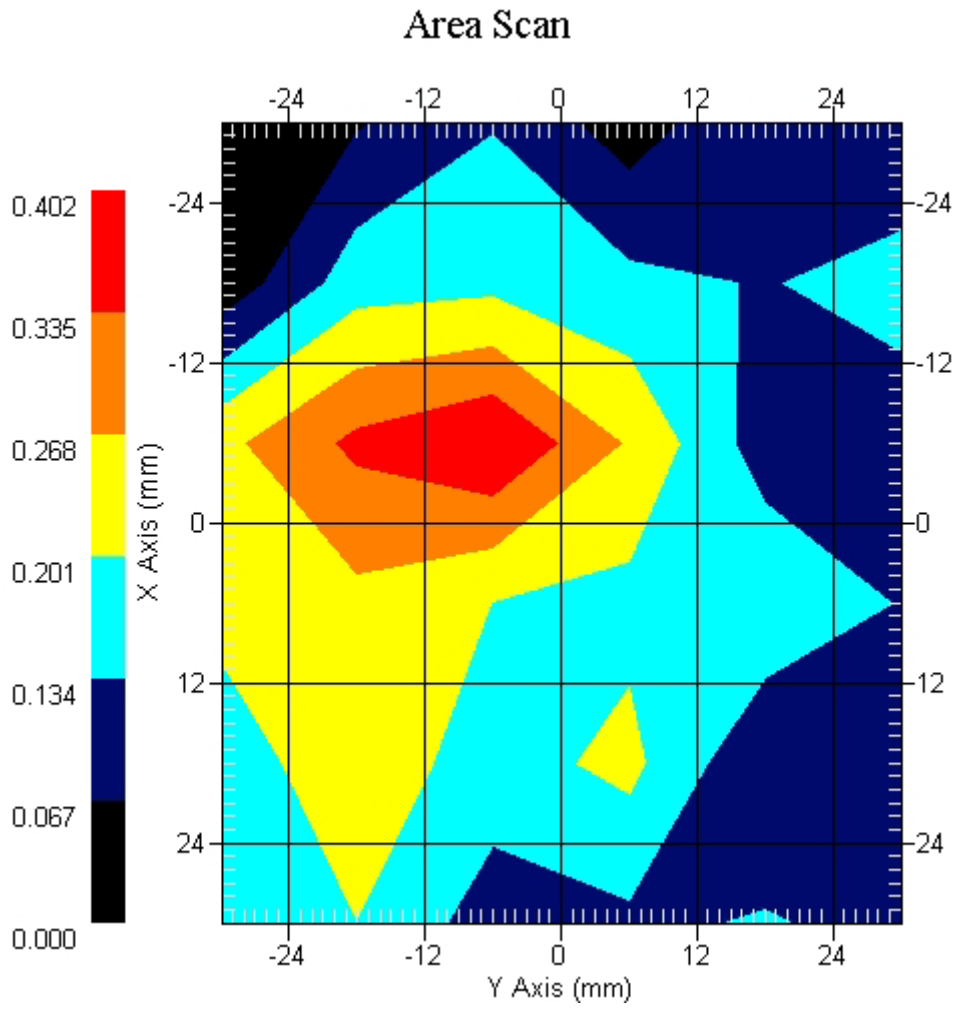

Measurement Data

Crest Factor : 8
 Tissue Temp. : 20.20 °C
 Ambient Temp. : 21.10 °C
 Area Scan : 6x6x1 : Measurement x=12mm, y=12mm, z=4mm
 Zoom Scan : 7x7x7 : Measurement x=5mm, y=5mm, z=5mm
 Power Drift-Start : 0.178 W/kg
 Power Drift-Finish: 0.181 W/kg
 Power Drift (%) : 1.685

DUT Position : Touch
 Channel : 810

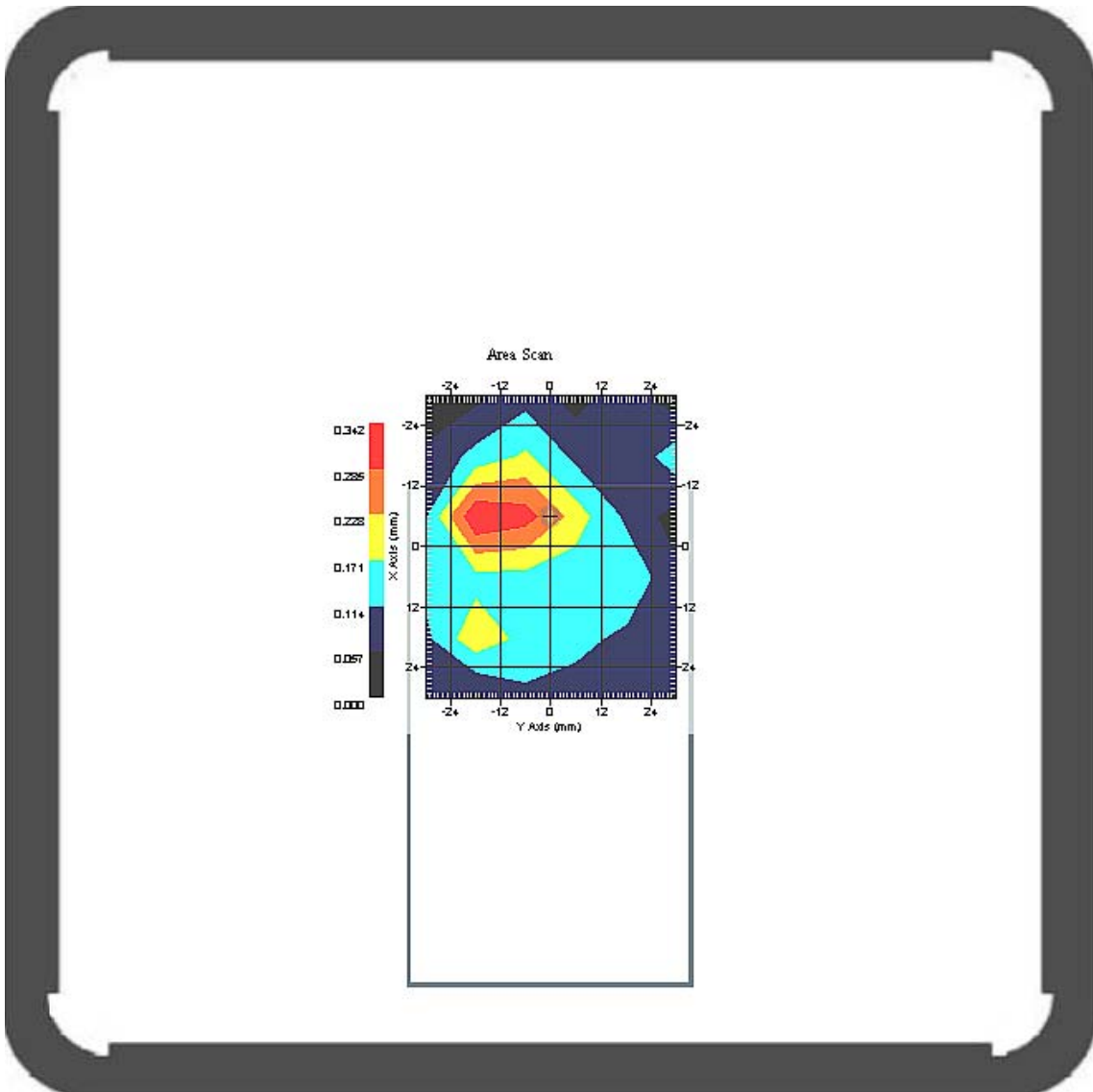

1 gram SAR value : 0.322 W/kg
 10 gram SAR value : 0.297 W/kg
 Area Scan Peak SAR : 0.340 W/kg
 Zoom Scan Peak SAR : 0.719 W/kg

This is previous page plot (zoom in)

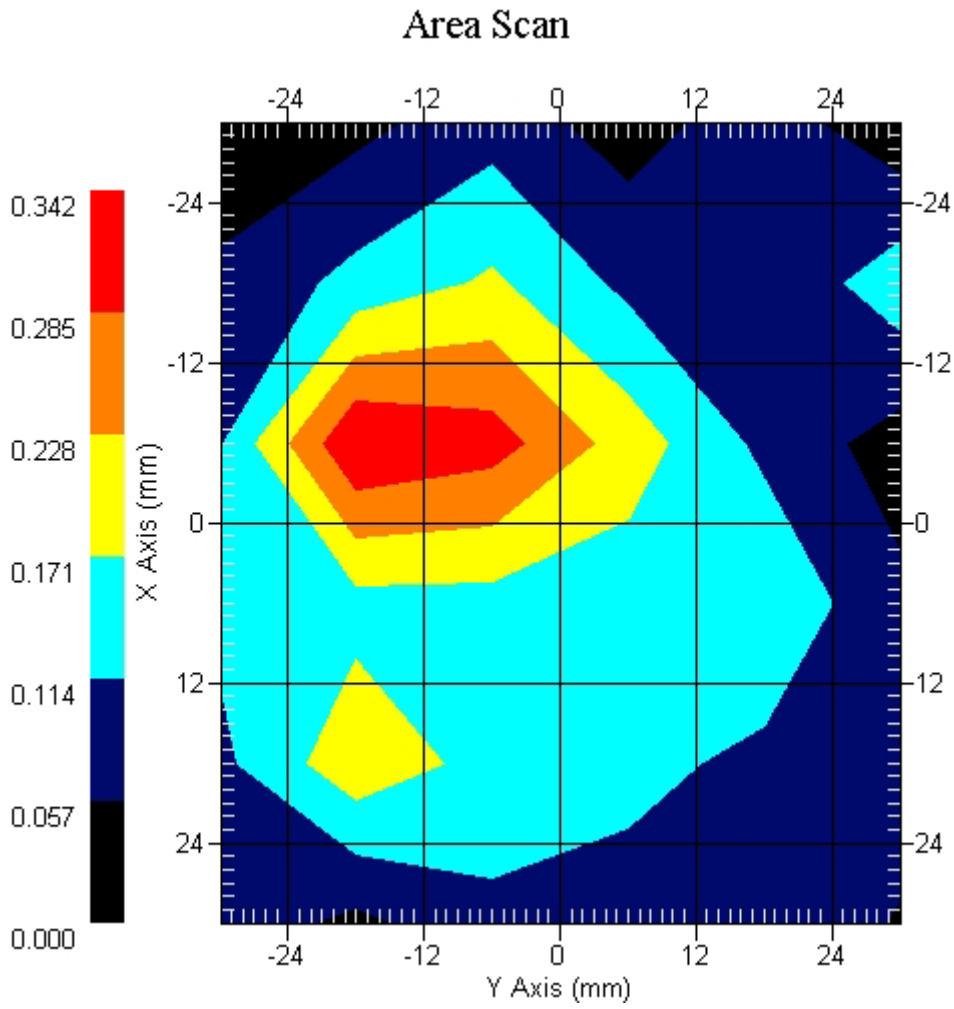

ALSAS-10U VER 2.3.2 APREL Laboratories
SAR Test ReportReport Date : 19-Feb-2008
Measurement Date : 19-Feb-2008

Product Data

Device Name : Mobile Phone
Type : Std Form Cell Phone
Model : B8
Frequency : 1900.00 MHz
Max. Transmit Pwr : 1 W
Drift Time : 0 min(s)
Length : 117.8 mm
Width : 67.9 mm
Depth : 15.8 mm
Antenna Type : Internal

Phantom Data

Type : Uni-Phantom
Size (mm) : 280 x 280 x 200
Location : Center

Tissue Data

Type : BODY
Serial No. : 324-B
Frequency : 1900.00 MHz
Last Calib. Date : 19-Feb-2007
Temperature : 20.20 °C
Ambient Temp. : 21.10 °C
Humidity : 50.00 RH%
Epsilon : 54.14 F/m
Sigma : 1.53 S/m
Density : 1000.00 kg/cu. m

Probe Data

Name : Probe 264
Model : E020
Type : E-Field Triangle
Serial No. : 264
Last Calib. Date : 21-Aug-2007
Frequency : 1900.00 MHz
Duty Cycle Factor: 4
Conversion Factor: 5.75
Probe Sensitivity: 1.20 1.20 1.20 $\mu\text{V}/(\text{V}/\text{m})^2$
Compression Point: 95.00 mV
Offset : 1.56 mm

Measurement Data

Crest Factor : 4
Tissue Temp. : 20.20 °C
Ambient Temp. : 21.10 °C
Area Scan : 6x6x1 : Measurement x=10mm, y=10mm, z=4mm
Zoom Scan : 7x7x7 : Measurement x=5mm, y=5mm, z=5mm
Power Drift-Start : 0.275 W/kg
Power Drift-Finish: 0.285 W/kg
Power Drift (%) : 3.520

DUT Position : Touch
Channel : 512

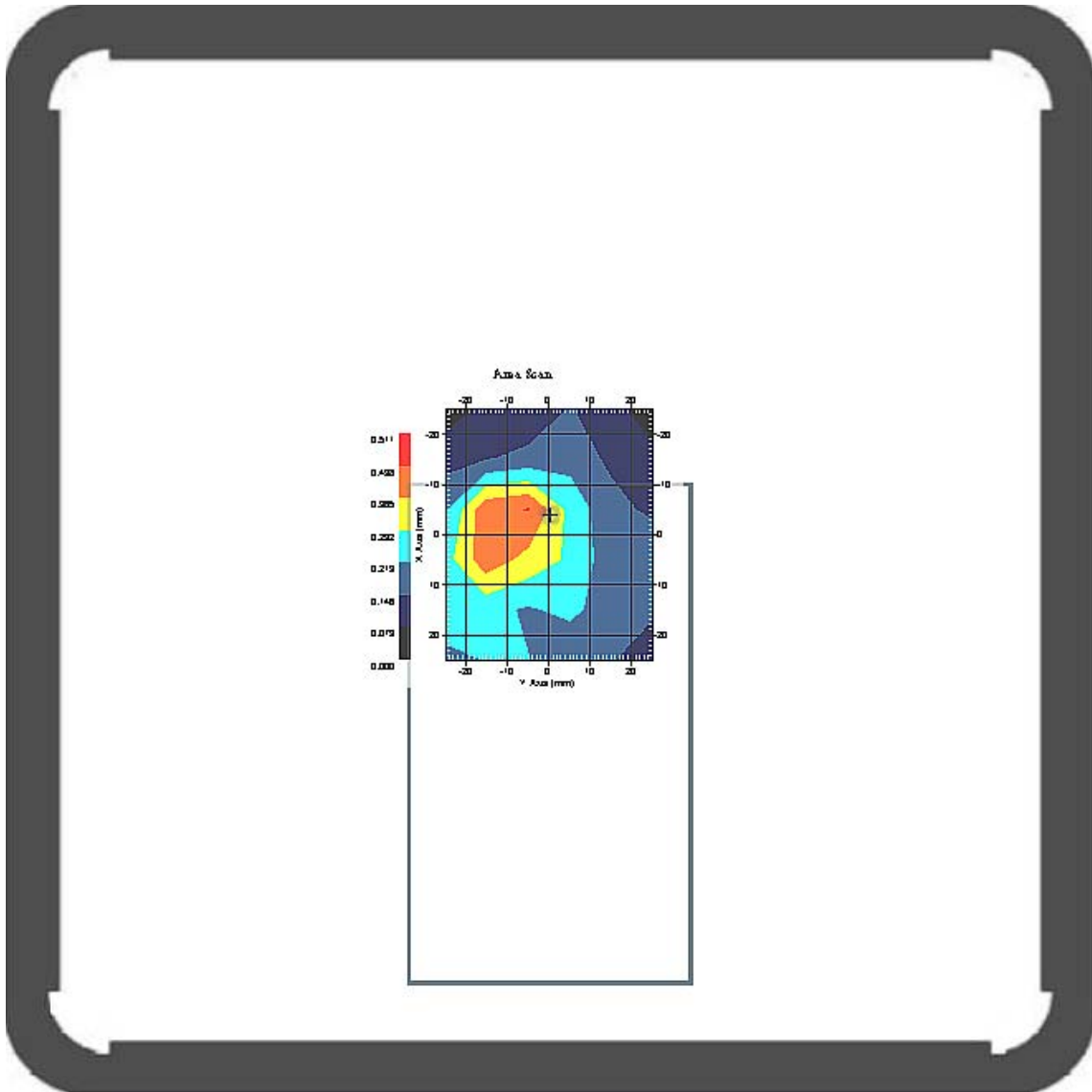

1 gram SAR value : 0.251 W/kg
10 gram SAR value : 0.147 W/kg
Area Scan Peak SAR : 0.440 W/kg
Zoom Scan Peak SAR : 0.489 W/kg

This is previous page plot (zoom in)

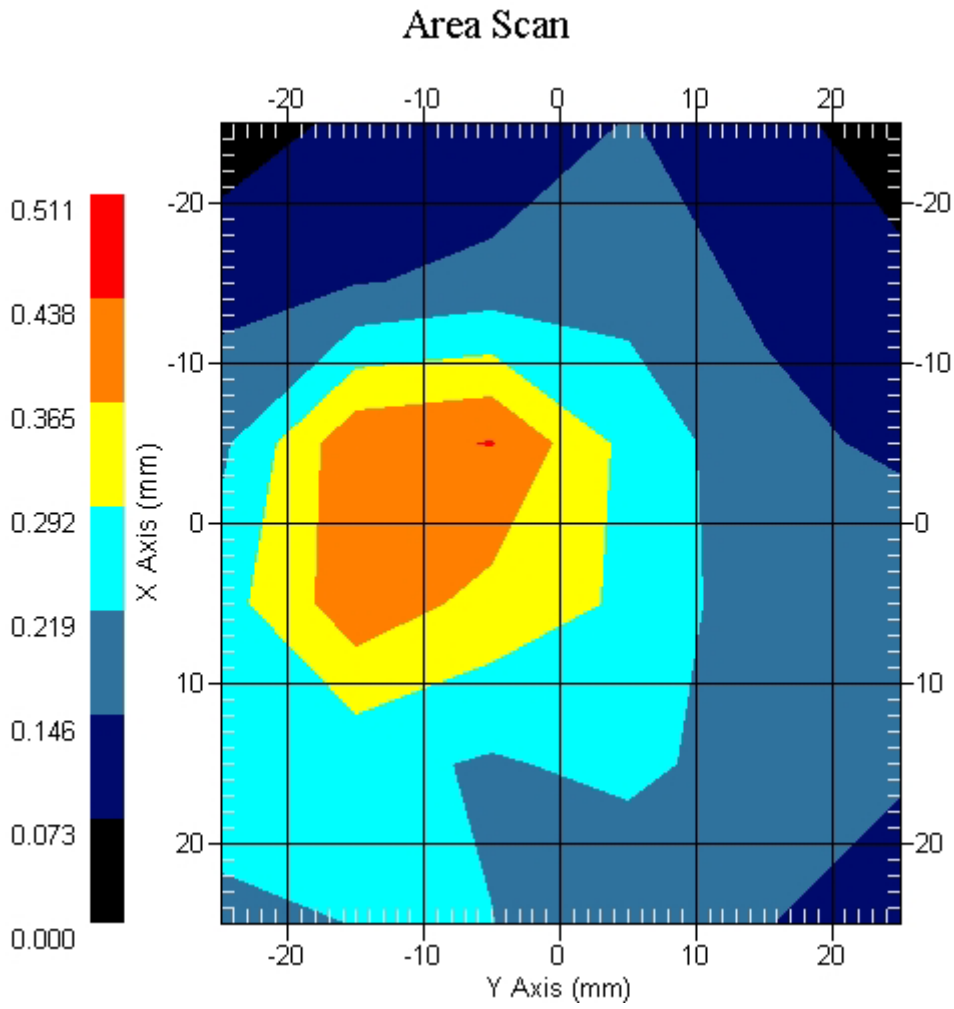

Measurement Data

Crest Factor : 4
Tissue Temp. : 20.20 °C
Ambient Temp. : 21.10 °C
Area Scan : 6x6x1 : Measurement x=10mm, y=10mm, z=4mm
Zoom Scan : 5x5x8 : Measurement x=8mm, y=8mm, z=4mm
Power Drift-Start : 0.281 W/kg
Power Drift-Finish: 0.290 W/kg
Power Drift (%) : 3.202

DUT Position : Touch
Channel : 661

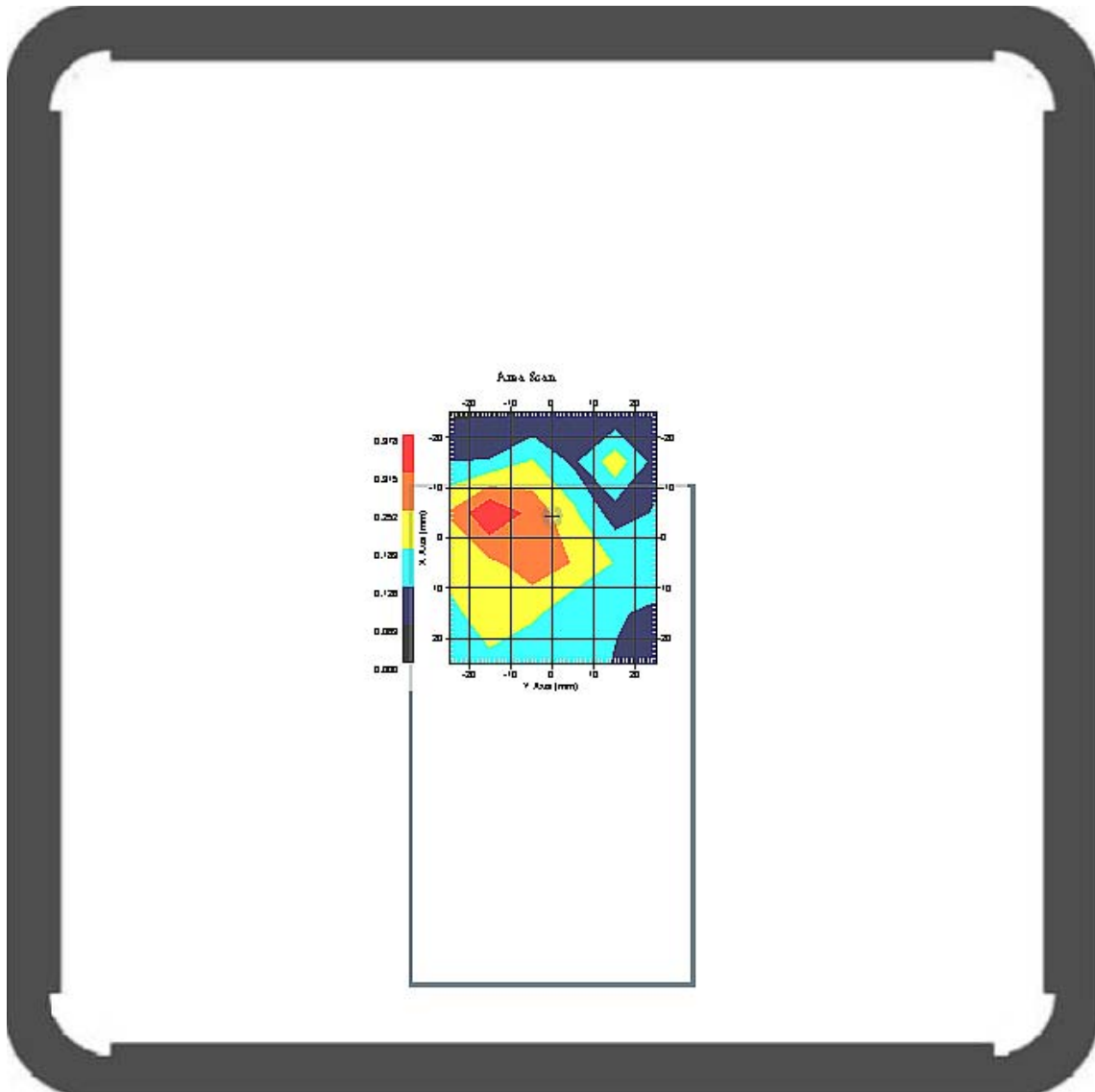

1 gram SAR value : 0.292 W/kg
10 gram SAR value : 0.181 W/kg
Area Scan Peak SAR : 0.378 W/kg
Zoom Scan Peak SAR : 0.370 W/kg

This is previous page plot (zoom in)

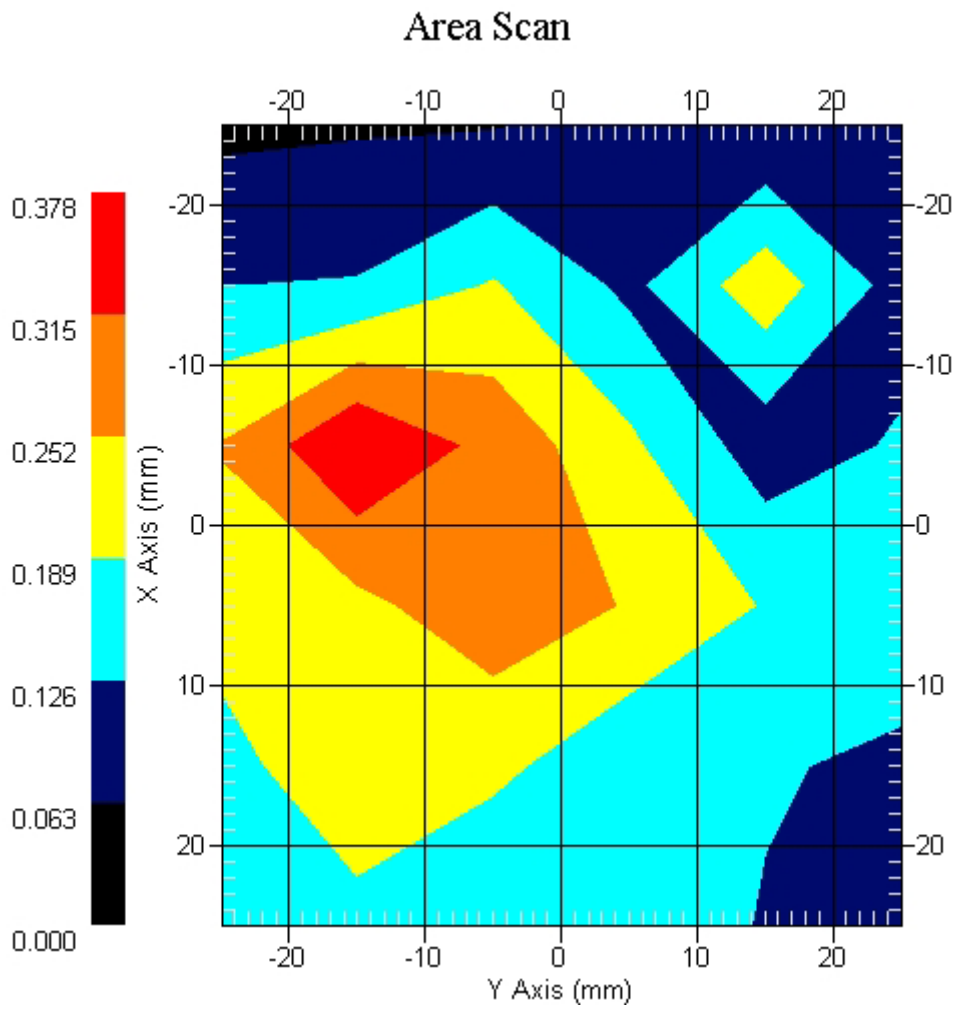

Measurement Data

Crest Factor : 4
Tissue Temp. : 20.20 °C
Ambient Temp. : 21.10 °C
Area Scan : 6x6x1 : Measurement x=10mm, y=10mm, z=4mm
Zoom Scan : 7x7x7 : Measurement x=5mm, y=5mm, z=5mm
Power Drift-Start : 0.336 W/kg
Power Drift-Finish: 0.344 W/kg
Power Drift (%) : 2.380

DUT Position : Touch
Channel : 810

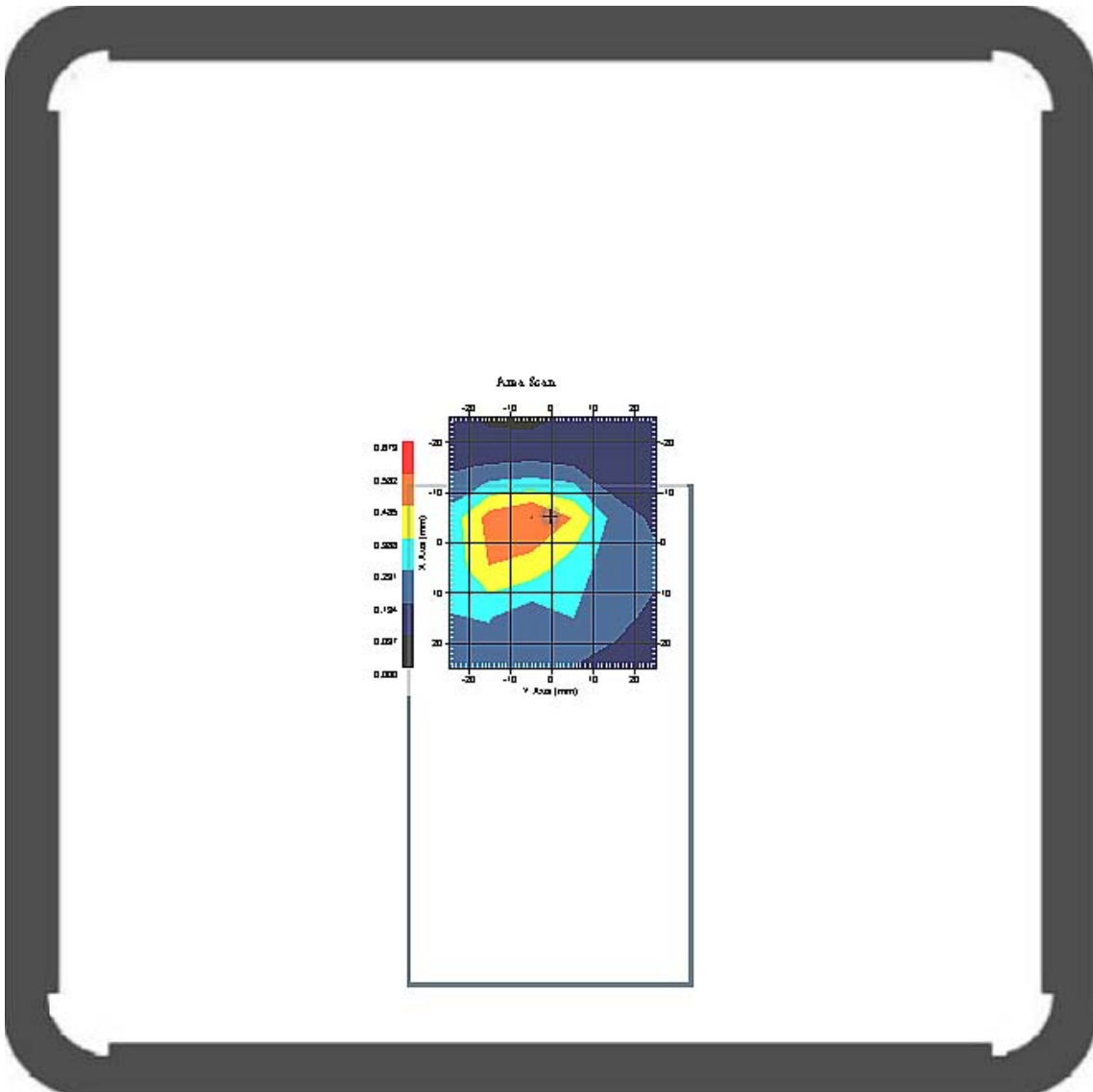

1 gram SAR value : 0.203 W/kg
10 gram SAR value : 0.139 W/kg
Area Scan Peak SAR : 0.583 W/kg
Zoom Scan Peak SAR : 0.412 W/kg

This is previous page plot (zoom in)

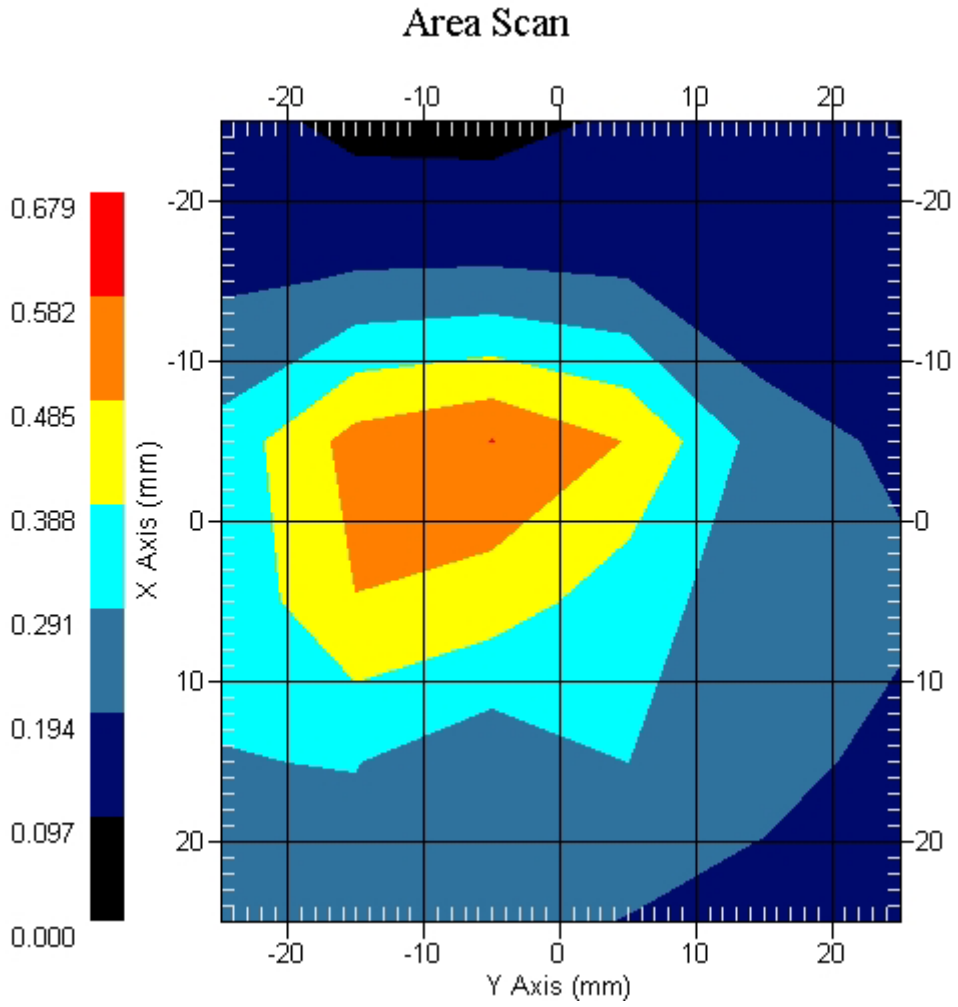

PCS 1900 EUT Left-Tilted Z-Axis plot
Channel: 512

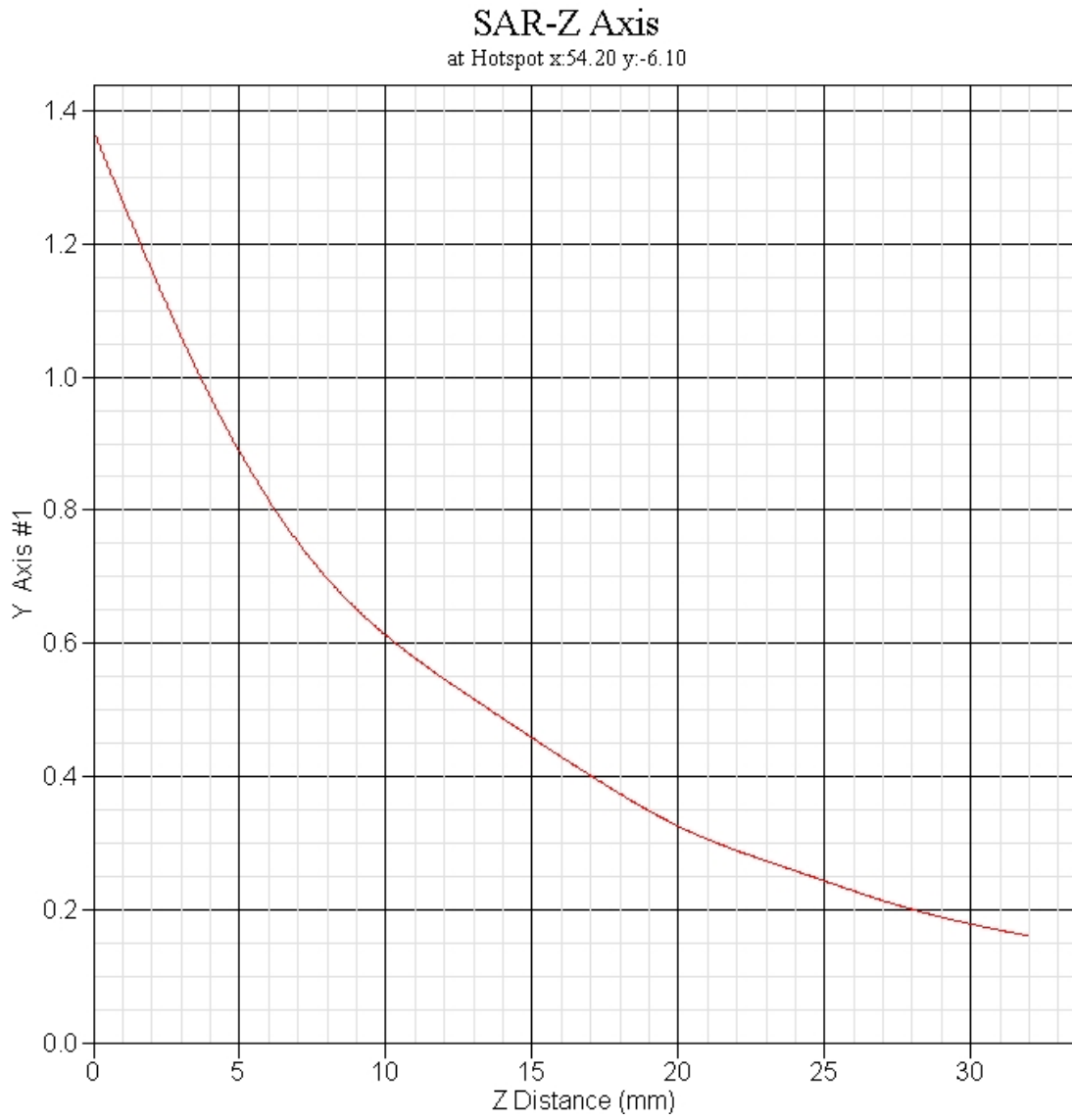

Appendix C. Test Setup Photographs & EUT Photographs
Test Setup Photographs

Right Head (EUT Cheek)

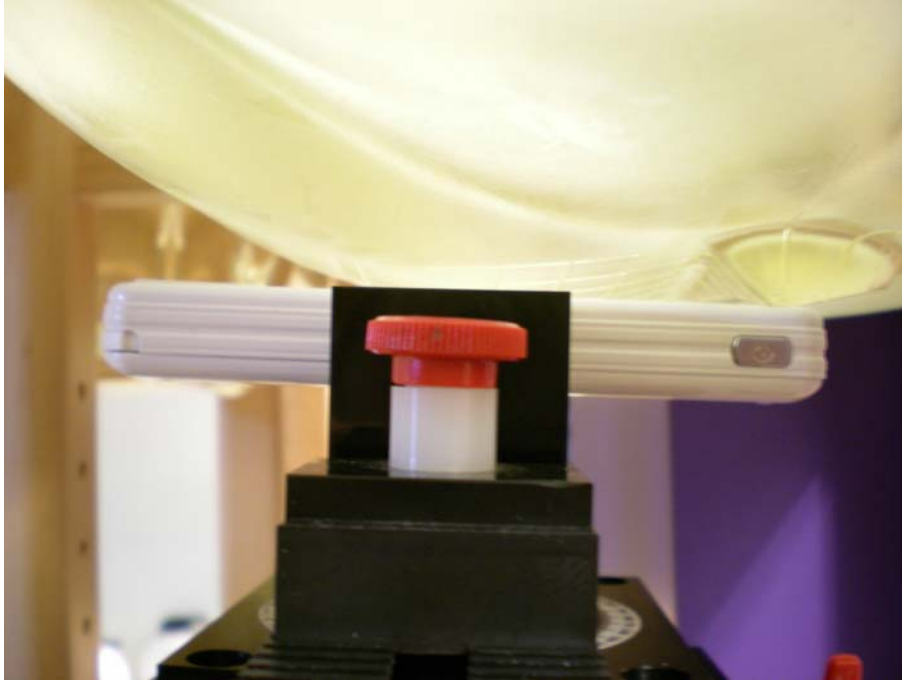

Left Head (EUT Cheek)



Right Head (EUT Tilted)

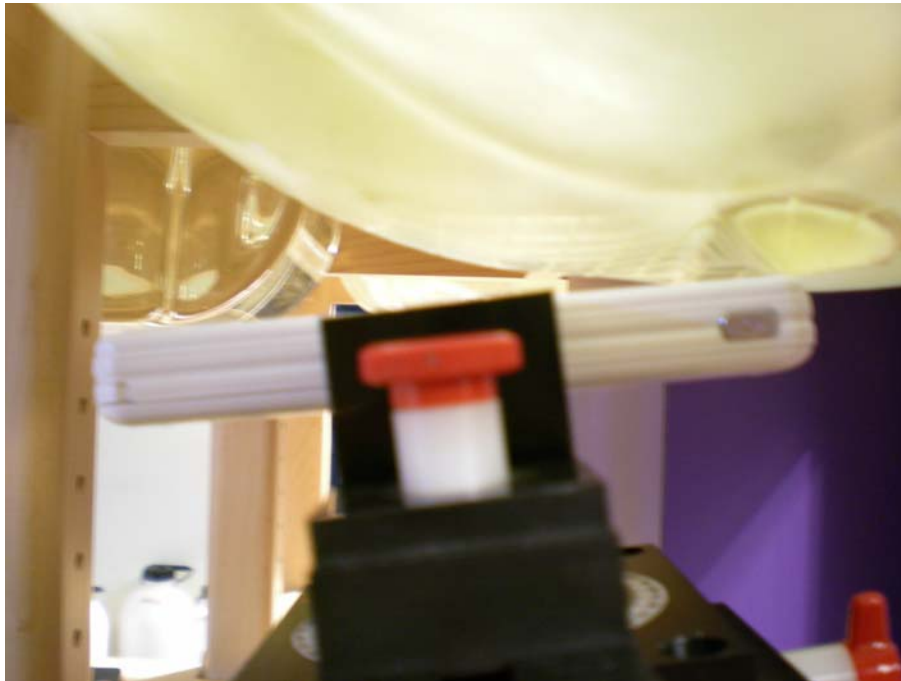

Left Head (EUT Tilted)

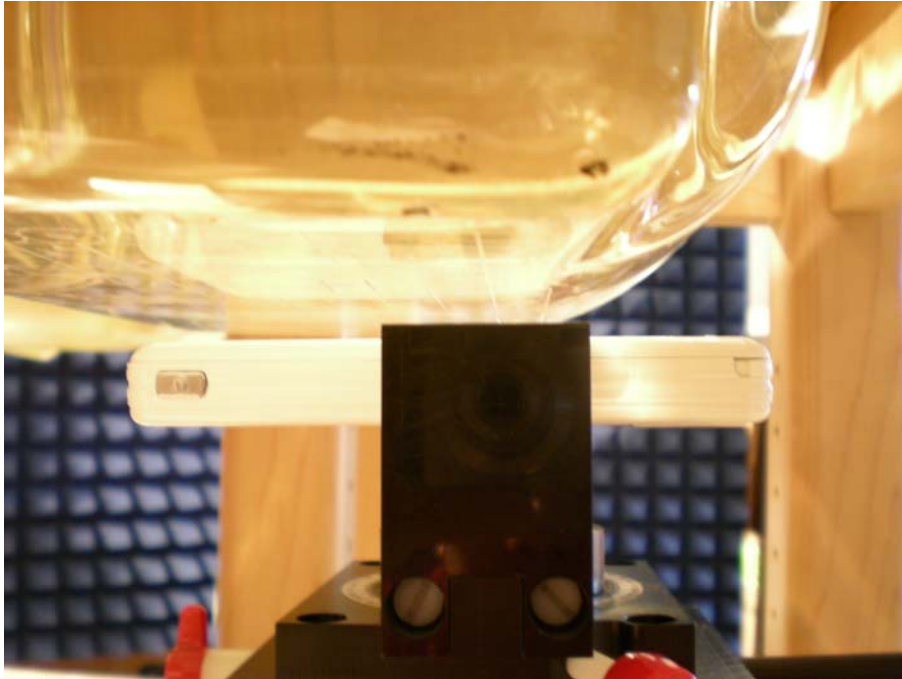

Body

Note: The positions used in the measurements were according to IEEE 1528-2003.

Test EUT Photographs





Appendix - Probe Calibration

Miniature Isotropic RF Probe

M/N: ALS-E-020

S/N: 264

835MHz Head Calibration

835MHz Body Calibration

NCL CALIBRATION LABORATORIES

Calibration File No.: CP-821

Client: QUIETEK

CERTIFICATE OF CALIBRATION

It is certified that the equipment identified below has been calibrated in the **NCL CALIBRATION LABORATORIES** by qualified personnel following recognized procedures and using transfer standards traceable to NRC/NIST.

Equipment: Miniature Isotropic RF Probe 835 MHz

Manufacturer: APREL Laboratories

Model No.: ALS-E-020

Serial No.: 264

HEAD Calibration

Calibration Procedure: SSI/DRB-TP-D01-032-E020-V2

Project No: QTKB-E-Probe-5305

Calibrated: 20th August 2007

Released on: 4th September 2007

This Calibration Certificate is Incomplete Unless Accompanied with the Calibration Results Summary

Released By: _____

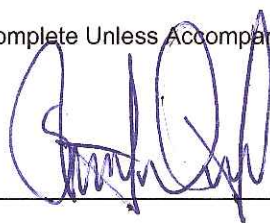

NCL CALIBRATION LABORATORIES

51 SPECTRUM WAY
NEPEAN, ONTARIO
CANADA K2R 1E6

Division of APREL Lab.
TEL: (613) 820-4988
FAX: (613) 820-4161

Introduction

This Calibration Report reproduces the results of the calibration performed in line with the SSI/DRB-TP-D01-032-E020-V2 E-Field Probe Calibration Procedure. The results contained within this report are for APREL E-Field Probe E-020 264.

References

SSI/DRB-TP-D01-032-E020-V2 E-Field Probe Calibration Procedure
IEEE 1528 "Recommended Practice for Determining the Peak Spatial-Average Specific Absorption Rate (SAR) in the Human Body Due to Wireless Communications Devices: Experimental Techniques"
SSI-TP-011 Tissue Calibration Procedure

Conditions

Probe 264 was a new probe taken from stock prior to calibration.

Ambient Temperature of the Laboratory: 22 °C +/- 0.5°C

Temperature of the Tissue: 21 °C +/- 0.5°C

We the undersigned attest that to the best of our knowledge the calibration of this probe has been accurately conducted and that all information contained within this report has been reviewed for accuracy.

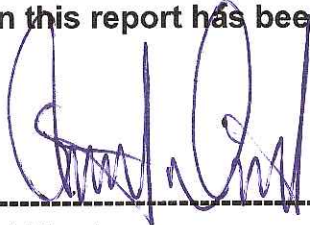

Stuart Nicol

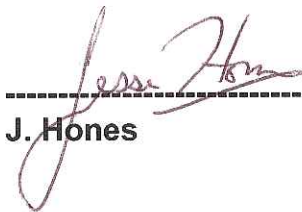

J. Hones

Calibration Results Summary

Probe Type:	E-Field Probe E-020
Serial Number:	264
Frequency:	835 MHz
Sensor Offset:	1.56 mm
Sensor Length:	2.5 mm
Tip Enclosure:	Ertalyte*
Tip Diameter:	<5 mm
Tip Length:	60 mm
Total Length:	290 mm

*Resistive to recommended tissue recipes per IEEE-1528

Sensitivity in Air

Channel X:	1.2 $\mu\text{V}/(\text{V}/\text{m})^2$
Channel Y:	1.2 $\mu\text{V}/(\text{V}/\text{m})^2$
Channel Z:	1.2 $\mu\text{V}/(\text{V}/\text{m})^2$
Diode Compression Point:	95 mV

Sensitivity in Head Tissue

Frequency: 835 MHz

Epsilon: 41.5 (+/-5%) **Sigma:** 0.90 S/m (+/-5%)

ConvF

Channel X: 6.3

Channel Y: 6.3

Channel Z: 6.3

Tissue sensitivity values were calculated using the load impedance of the APREL Laboratories Daq-Paq.

Boundary Effect:

Uncertainty resulting from the boundary effect is less than 2% for the distance between the tip of the probe and the tissue boundary, when less than 2.44mm.

Spatial Resolution:

The measured probe tip diameter is 5 mm (+/- 0.01 mm) and therefore meets the requirements of SSI/DRB-TP-D01-032 for spatial resolution.

Receiving Pattern 835 MHz (Air)

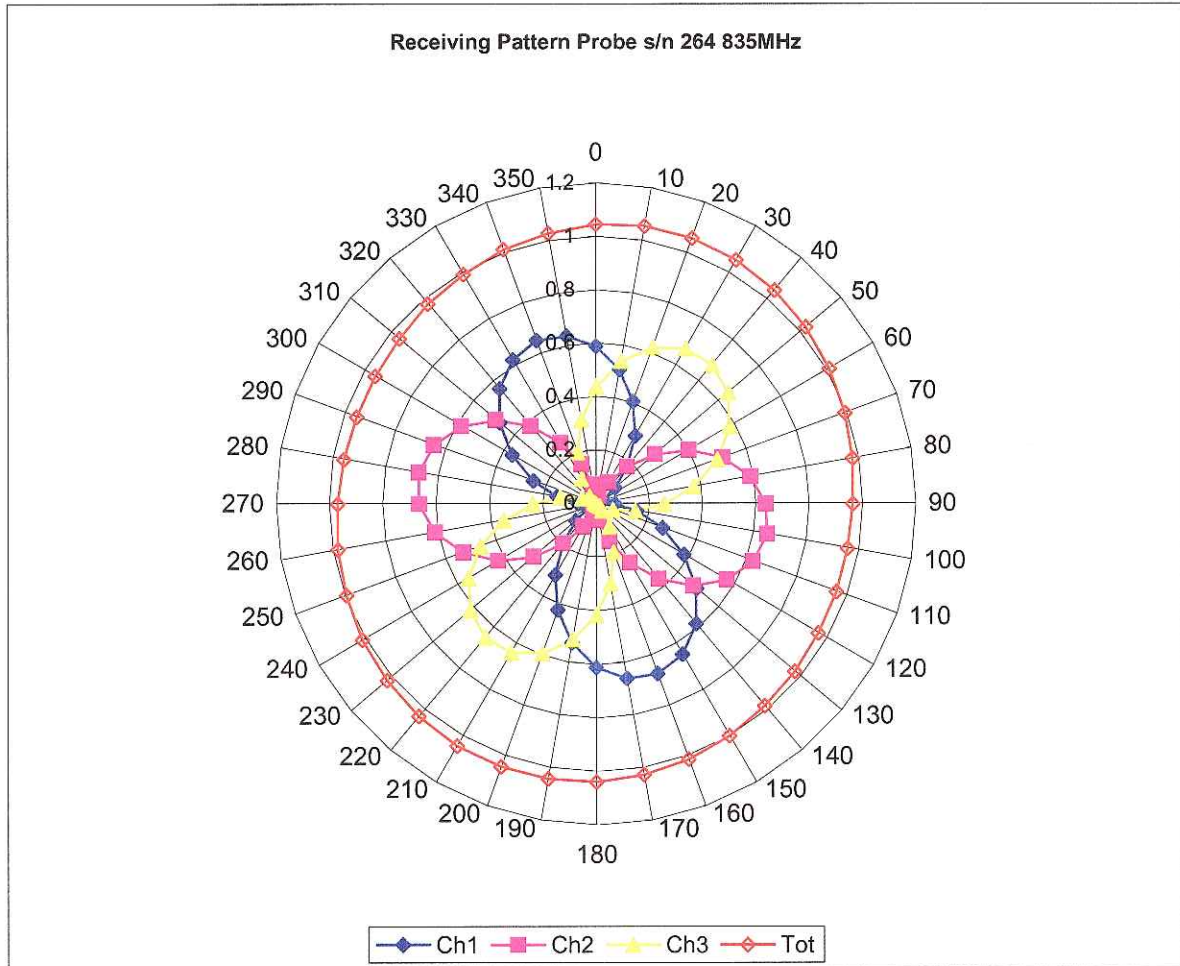

Isotropy Error 835 MHz (Air)

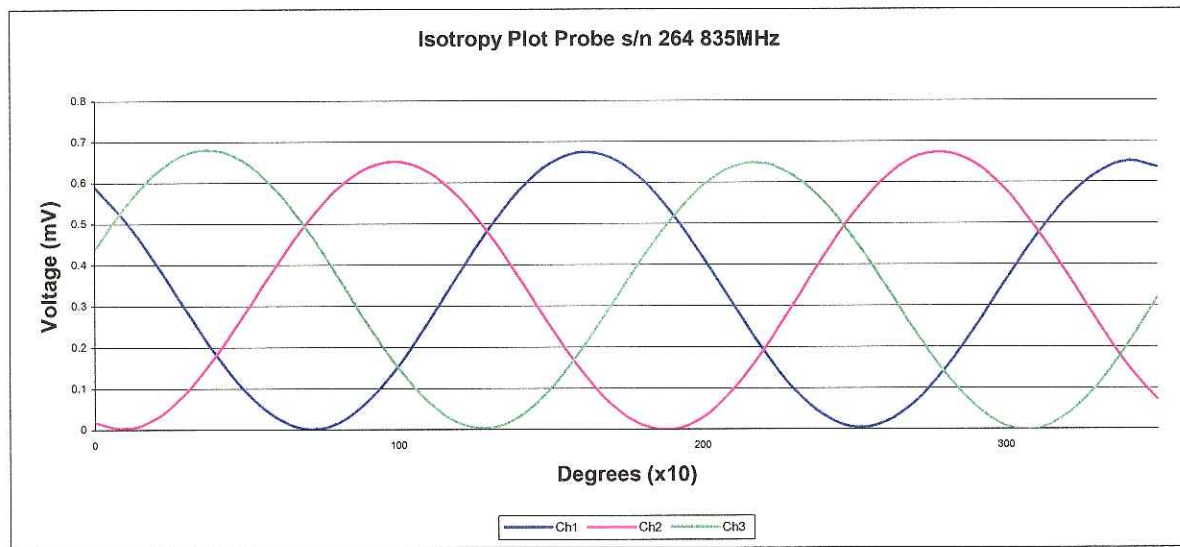
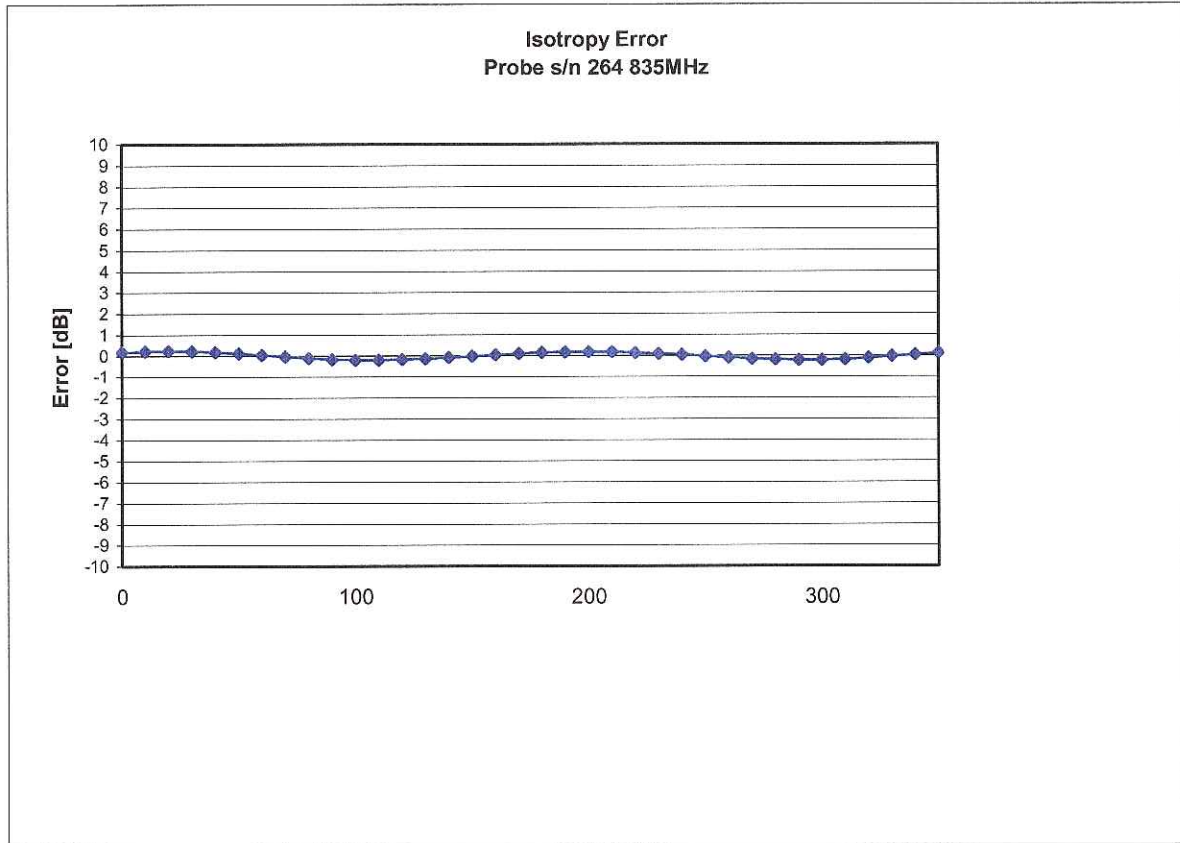

Isotropicity Tissue:

0.10 dB

Dynamic Range

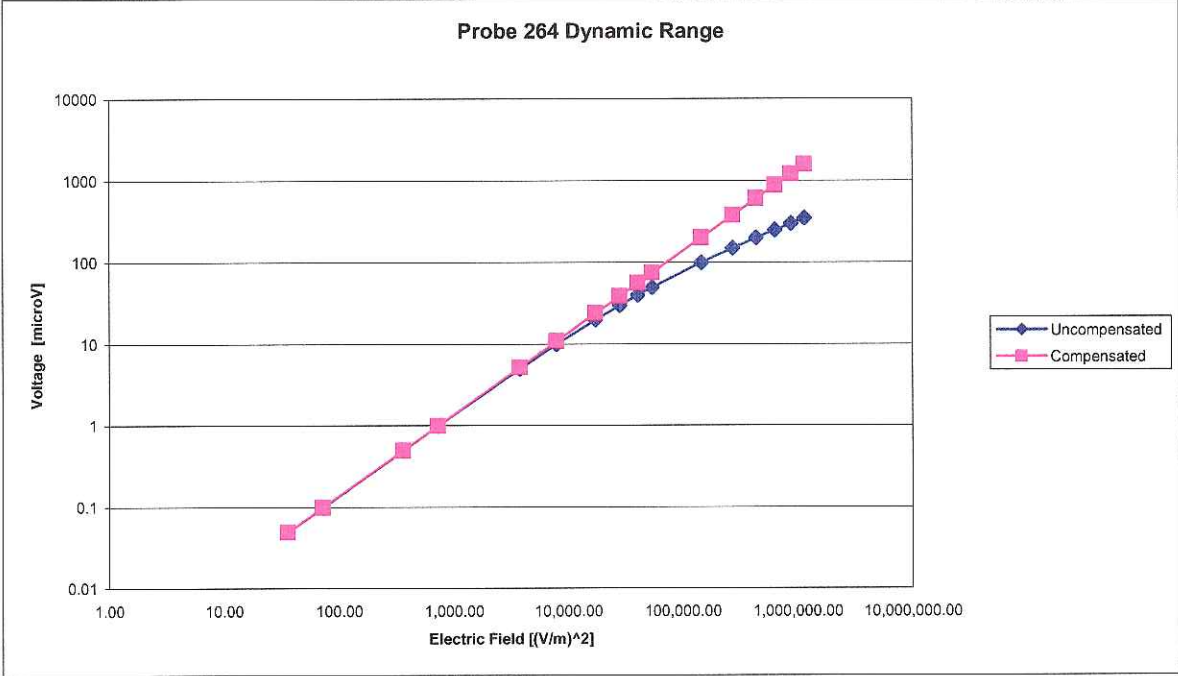

Video Bandwidth

Probe Frequency Characteristics

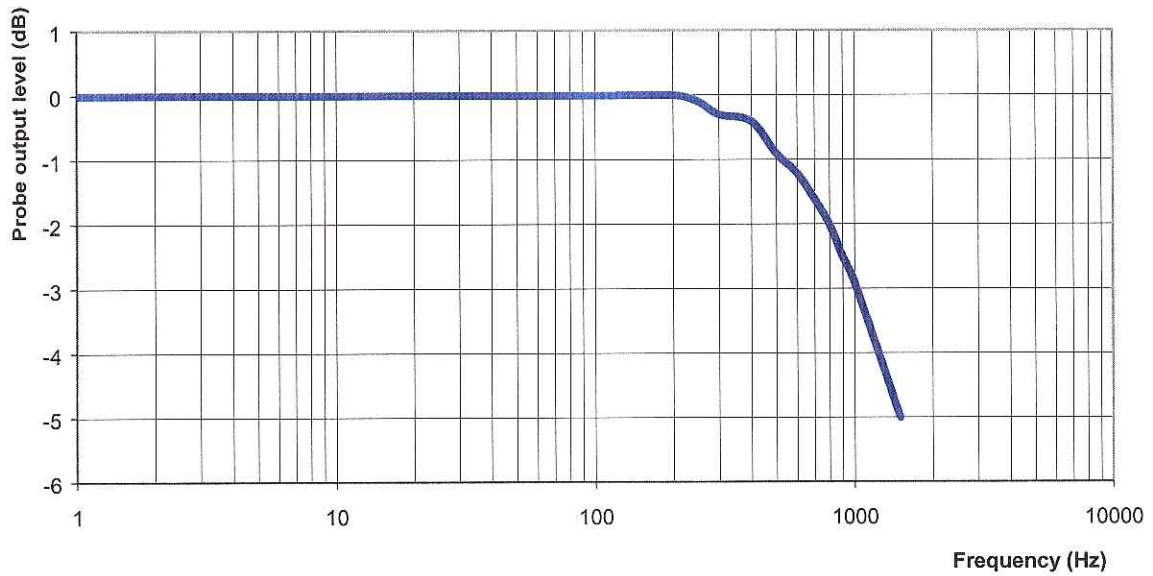

Video Bandwidth at 500 Hz 1 dB
Video Bandwidth at 1000 Hz 3 dB

Conversion Factor Uncertainty Assessment

Frequency: 835MHz
Epsilon: 41.5 (+/-5%) **Sigma:** 0.90 S/m (+/-5%)

ConvF

Channel X: 6.3 7%(K=2)
Channel Y: 6.3 7%(K=2)
Channel Z: 6.3 7%(K=2)

To minimize the uncertainty calculation all tissue sensitivity values were calculated using a load impedance of 5 MΩ.

Boundary Effect:

For a distance of 2.4mm the evaluated uncertainty (increase in the probe sensitivity) is less than 2%.