

**ELECTROMAGNETIC EMISSIONS COMPLIANCE REPORT
INTENTIONAL RADIATOR CERTIFICATION TO
FCC PART 15 SUBPART C REQUIREMENT**

OF

8DN Weather Sation

MODEL No.: DF08012-27-XXX(X=A-Z, a-z, 0-9); DPF8WS-WA; QUMO QS800.02

FCC ID: V37-WS8DNSP02

REPORT NO: ED10050058-2

ISSUE DATE: June 08, 2010

Prepared for

**WIN ACCORD LTD.
12F, NO. 225, SEC 5, 105 SONG SHAN DIST.,
NAN JING EAST ROAD, TAIPEI, TAIWAN**

Prepared by

DONGGUAN EMTEK Co., Ltd.

**No.281, Guantai Road, Nancheng District,
Dongguan, Guangdong, China
TEL: 86-769-22807078
FAX: 86-769-22807079**

VERIFICATION OF COMPLIANCE

Applicant:	WIN ACCORD LTD. 12F, NO. 225, SEC 5, 105 SONG SHAN DIST., NAN JING EAST ROAD, TAIPEI, TAIWAN
Manufacturer	WIN ACCORD LTD. 12F, NO. 225, SEC 5, 105 SONG SHAN DIST., NAN JING EAST ROAD, TAIPEI, TAIWAN
Product Description:	8DN Weather Sation
Model Number:	Basic Model: DF08012-27-XXX(X=A-Z, a-z, 0-9); Additional Model: DPF8WS-WA; QUMO QS800.02 (Note: Those models are the same except appearance and model names, all models use the same FCC ID Number.)
Serial Number:	N/A
File Number:	ED10050058-2
Date of Test:	May 18, 2010 to June 08 2010

We hereby certify that:

The above equipment was tested by DONGGUAN EMTEK Co., Ltd. The test data, data evaluation, test procedures, and equipment configurations shown in this report were made in accordance with the procedures given in ANSI C63.4 (2003) and the energy emitted by the sample EUT tested as described in this report is in compliance with conducted and radiated emission limits of FCC 15 Paragraph 15.205, Paragraph 15.209, Paragraph 15.231, Paragraph 15.31, Paragraph 15.33, Paragraph 15.35.

The test results of this report relate only to the tested sample identified in this report.

Approved By

Nicol Lee/ Q.A. Manager
DONGGUAN EMTEK Co., Ltd.

Table of Contents

- 1. GENERAL INFORMATION.....4**
 - 1.1 PRODUCT DESCRIPTION..... 4
 - 1.2 RELATED SUBMITTAL(S) / GRANT (S) 4
 - 1.3 TEST METHODOLOGY..... 4
 - 1.4 SPECIAL ACCESSORIES 4
 - 1.5 EQUIPMENT MODIFICATIONS 4
 - 1.6 TEST FACILITY 5
- 2. SYSTEM TEST CONFIGURATION 6**
 - 2.1 EUT CONFIGURATION..... 6
 - 2.2 EUT EXERCISE 6
 - 2.3 TEST PROCEDURE..... 6
 - 2.4 LIMITATION 7
 - 2.5 CONFIGURATION OF TESTED SYSTEM 8
- 3. SUMMARY OF TEST RESULTS 9**
- 4. DESCRIPTION OF TEST MODES 9**
- 5. CONDUCTED EMISSIONS TEST (NOT APPLICABLE IN THIS REPORT)..... 10**
 - 5.1 MEASUREMENT PROCEDURE:..... 10
 - 5.2 TEST SET-UP (BLOCK DIAGRAM OF CONFIGURATION) 10
 - 5.3 MEASUREMENT EQUIPMENT USED: 10
 - 5.4 MEASUREMENT RESULT:..... 10
 - 5.5 CONDUCTED MEASUREMENT PHOTOS: 10
- 6. RADIATED EMISSION TEST 11**
 - 6.1 MEASUREMENT PROCEDURE..... 11
 - 6.2 TEST SET-UP (BLOCK DIAGRAM OF CONFIGURATION) 12
 - 6.3 MEASUREMENT EQUIPMENT USED: 13
 - 6.4 MEASUREMENT RESULT..... 14
- 7. DEACTIVATION TESTING 16**
 - 7.1 REQUIREMENT..... 16
 - 7.2 TEST SET-UP 16
 - 7.3 MEASUREMENT EQUIPMENT USED: 16
 - 7.4 TEST PROCEDURE 16
 - 7.5 TEST DATA 16
- 8. OCCUPIED BANDWIDTH..... 18**
 - 8.1 MEASUREMENT PROCEDURE..... 18
 - 8.2 TEST SET-UP (BLOCK DIAGRAM OF CONFIGURATION) 18
 - 8.3 MEASUREMENT EQUIPMENT USED: 18
 - 8.4 MEASUREMENT RESULTS:..... 18

PHOTOGRAPHS OF SET UP 20

1. GENERAL INFORMATION

1.1 Product Description

The Elgin molded plastic, Inc Model: SMM-08 (referred to as the EUT in this report) The EUT is an short range, lower power, 8DN Weather Sation designed as an Input Device. A major technical descriptions of EUT is described as following:

- A). Operation Frequency: 868 MHz, one channel.
- B). Power Supply: DC3V AA Battery*2

1.2 Related Submittal(s) / Grant (s)

This submittal(s) (test report) is intended for FCC ID: V37-WS8DNSP02 filing to comply with Section 15.231 of the FCC Part 15, Subpart C Rules. The composite system (receiver) is compliance with Subpart B is authorized under a DoC procedure.

1.3 Test Methodology

Both conducted and radiated testing were performed according to the procedures in ANSI C63.4 (2003). Radiated testing was performed at an antenna to EUT distance 3 meters.

1.4 Special Accessories

Not available for this EUT intended for grant.

1.5 Equipment Modifications

Not available for this EUT intended for grant.

1.6 Test Facility

Site Description
EMC Lab. : Accredited by CNAS, 2005.11.02
The certificate is valid until 2010.11
The Laboratory has been assessed and proved to be in compliance
with CNAS/CL01:2006(identical to ISO/IEC17025:2005)
The Certificate Registration Number is L2291

Accredited by TUV Rheinland Shenzhen, 2009,9
The certificate is valid until 2011,3
The Laboratory has been assessed according to the requirements
ISO/IEC 17025

Accredited by FCC, Nov. 05, 2008
The Certificate Registration Number is 247565.

Accredited by Industry Canada, May 24, 2008
The Certificate Registration Number is 46405-4480

Name of Firm : DONGGUAN EMTEK CO., LTD
Site Location : No.281, Guantai Road, Nancheng District,
Dongguan, Guangdong, China

2. System Test Configuration

2.1 EUT Configuration

The EUT configuration for testing is installed on RF field strength measurement to meet the Commissions requirement and operating in a manner which intends to maximize its emission characteristics in a continuous normal application.

2.2 EUT Exercise

The Transmitter was operated in the normal operating mode. the Tx frequency was fixed which was for the purpose of the measurements.

2.3 Test Procedure

2.3.1 Conducted Emissions (Not apply in the report)

The EUT is a placed on as turn table which is 0.8 m above ground plane. According to the requirements in Section 13.1.4.1 of ANSI C63.4-2003. Conducted emissions from the EUT measured in the **frequency range between 0.15 MHz and 30MHz** using **CISPR Quasi-Peak and average detector mode**.

2.3.2 Radiated Emissions

The EUT is a placed on as turn table which is 0.8 m above ground plane. The turn table shall rotate 360 degrees to determine the position of maximum emission level. EUT is set 3m away from the receiving antenna which varied from 1m to 4m to find out the highest emission. And also, each emission was to be maximized by changing the polarization of receiving antenna both horizontal and vertical. In order to find out the max. emission, the relative positions of this hand-held transmitter(EUT) was rotated through three orthogonal axes according to the requirements in Section 13.1.4.1 of ANSI C63.4-2003.

2.4 Limitation

(1) Conducted Emission (Not applicable in this report)

According to section 15.207(a) Conducted Emission Limits is as following.

Frequency range MHz	Limits dB(uV)	
	Quasi-peak	Average
0.15 to 0.50	66 to 56	56 to 46
0.50 to 5	56	46
5 to 30	60	50

Note
 1. The lower limit shall apply at the transition frequencies
 2. The limit decreases linearly with the logarithm of the frequency in the range 0.15 MHz to 0.50 MHz.

(2) Radiated Emission

- a. The field strength of any emission within this band (section 15.231) shall not exceed 10000 micro volts/meter at 3 meters. (80dBµV at 3m) The emission limit in this paragraph is based on measurement instrumentation employing an average detector. The provisions in section 15.35 for limiting peak emissions apply.
- b. The field strength of any emissions which appear outside of this band shall not exceed the general radiated emission limits in section 15.209 and section 15.231(Intentional Radiators general limit). as below.

Frequency (MHz)	Field strength µV/m	Distance (m)	Field strength at 3m dBµV/m
30-88	100	3	40
88-216	150	3	43.5
216-960	200	3	46
Above 960	500	3	54

- Remark:
- 1. Emission level in dBuV/m=20 log (uV/m)
 - 2. Measurement was performed at an antenna to the closed point of EUT distance of meters.
 - 3. Only spurious frequency is permitted to locate within the Restricted Bands specified in provision of § 15.205
 - 4. Emission spurious frequency which appearing within the Restricted Bands specified in provision of §15.205, then the general radiated emission limits in § 15.209 apply.

Fundamental Frequency(MHZ)	Field Strength of Fundamental	
	uV/m	dBuV/m
868	12500	81.94
Harmonics	1250	61.94

Remark: (1) Emission level in dBuV/m=20 log (uV/m)
(2) Distance refers to the distance in meters between the measuring instrument antenna and the closed point of any part of the device or system.
(3)The emission limit in this paragraph is based on measurement instrumentation employing an average detector. Measurement using instrumentation with a peak detector function, corresponding to 20dB above the maximum permitted average limit

2.5 Configuration of Tested System

Fig. 2-1 Configuration of Tested System



3. Summary Of Test Results

FCC Rules	Description Of Test	Result
§ 15.207	Conducted Emission	N/A
§ 15.231 (b)	Radiated Emission	Compliant
§ 15.231 (c)	Bandwidth Test	Compliant
§ 15.231 (a)(2)	Deactivation Testing	Compliant

4. Description of test modes

The EUT (8DN Weather Sation) has been tested under normal operating condition.
The EUT stay in continuous transmitting mode. The Frequency 868MHz are chosen for testing.

5. Conducted Emissions Test (Not applicable in this report)

5.1 Measurement Procedure:

1. The EUT was placed on a table which is 0.8m above ground plane.
2. Maximum procedure was performed on the six highest emissions to ensure EUT compliance.
3. Repeat above procedures until all frequency measured were complete.

5.2 Test SET-UP (Block Diagram of Configuration)

5.3 Measurement Equipment Used:

Conducted Emission Test Site # 4					
EQUIPMENT TYPE	MFR	MODEL NUMBER	SERIAL NUMBER	LAST CAL.	CAL DUE.
Test Receiver	Rohde & Schwarz	ESCS30	828985/018	05/29/2010	05/29/2011
L.I.S.N	Rohde & Schwarz	ESH2-Z5	834549/005	05/29/2010	05/29/2011
L.I.S.N	Rohde & Schwarz	ESH2-Z5	834549/005	05/29/2010	05/29/2011
50ΩCoaxial Switch	Anritsu	MP59B	M20531	05/29/2010	05/29/2011

5.4 Measurement Result:

N/A

5.5 Conducted Measurement Photos:

N/A

6. Radiated Emission Test

6.1 Measurement Procedure

1. The EUT was placed on a turn table which is 0.8m above ground plane.
2. Maximum procedure was performed on the six highest emissions to ensure EUT compliance.
3. And also, each emission was to be maximized by changing the polarization of receiving antenna both horizontal and vertical.
4. Repeat above procedures until all frequency measured were complete.

6.2 Test SET-UP (Block Diagram of Configuration)

(A) Radiated Emission Test Set-Up, Frequency Below 30MHz

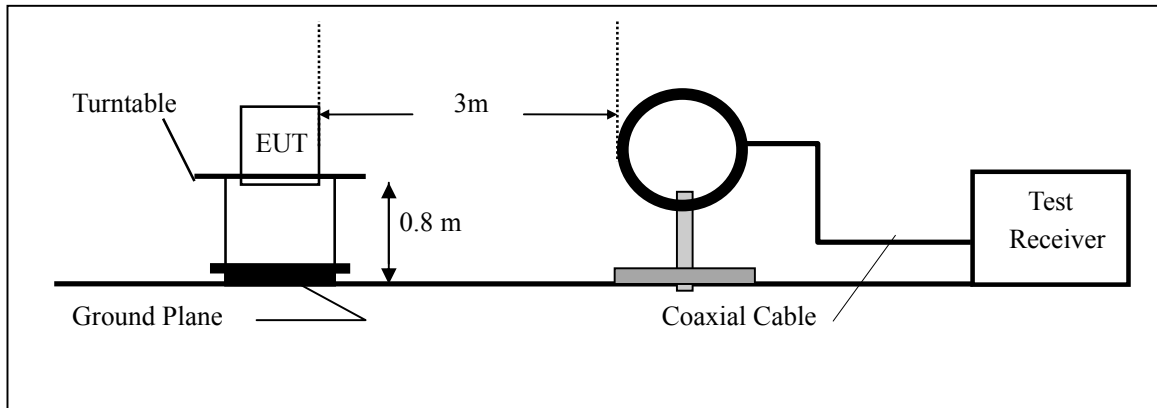

(B) Radiated Emission Test Set-Up, Frequency Below 1000MHz

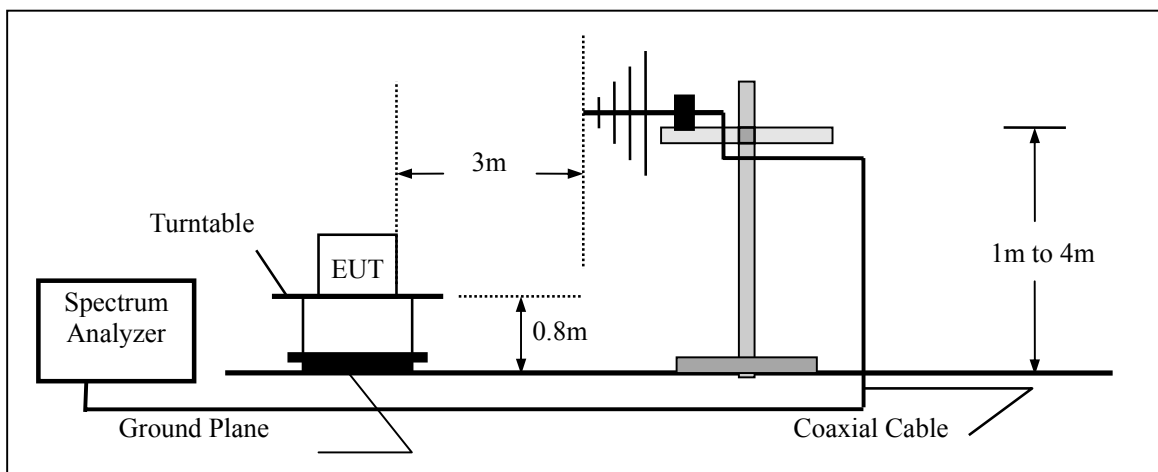

(C) Radiated Emission Test Set-Up, Frequency above 1000MHz

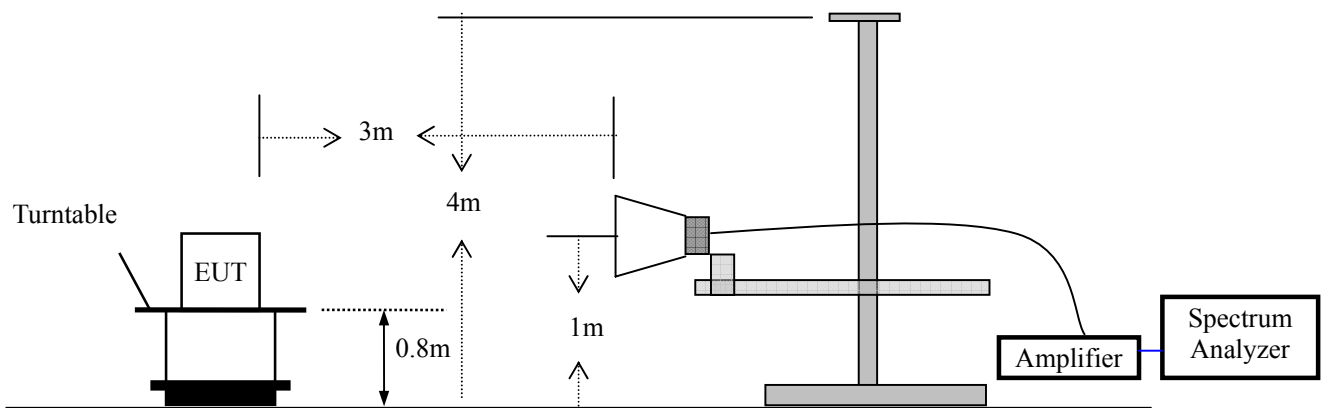

6.3 Measurement Equipment Used:

EQUIPMENT TYPE	MFR	MODEL NUMBER	SERIAL NUMBER	LAST CAL.	CAL DUE.
Spectrum Analyzer	Rohde & Schwarz	FSP7	839511/010	05/29/2010	05/29/2011
Spectrum Analyzer	HP	E4407B	839840481	05/29/2010	05/29/2011
EMI Test Receiver	Rohde & Schwarz	ESCS30	828985/018	05/29/2010	05/29/2011
Pre-Amplifier	HP	8447D	2944A07999	05/29/2010	05/29/2011
Bilog Antenna	Schwarzbeck	VULB9163	142	05/29/2010	05/29/2011
Loop Antenna	ARA	PLA-1030/B	1029	05/29/2010	05/29/2011
Horn Antenna	Electro-Metrics	EM-6961	103314	05/29/2010	05/29/2011
Horn Antenna	Schwarzbeck	BBHA 9120	D143	05/29/2010	05/29/2011

7. DEACTIVATION TESTING

7.1 Requirement

Per 15.231(a) (2), A transmitter activated automatically shall cease transmission within 5 seconds after activation.

7.2 Test SET-UP

Same as 6.2 Radiated Emission Measurements.

7.3 Measurement Equipment Used:

EQUIPMENT TYPE	MFR	MODEL NUMBER	SERIAL NUMBER	LAST CAL.	CAL DUE.
EMI Test Receiver	Rohde & Schwarz	ESCS30	828985/018	05/29/2010	05/29/2011
Pre-Amplifier	HP	8447D	2944A07999	05/29/2010	05/29/2011
Broadband Antenna	Sunol Sciences	JB1	A040904-2	05/29/2010	05/29/2011

7.4 Test Procedure

1. The deactivation test was performed in the 3 meters chamber B test site, using the setup accordance with the ANSI C63.4 - 2003. The specification used was the FCC 15.231(a) limits.
2. Maximizing procedure was performed on the highest emissions to ensure that the EUT complied with all installation combinations.

7.5 Test Data

Environmental Conditions

Temperature:	23 ° C
Relative Humidity:	56%
ATM Pressure:	1032mbar

Test Mode: Transmitting

Transmitting time	Limit (Second)	Result
362.5ms	5	PASS

Refer to the attached Duty Cycle plot

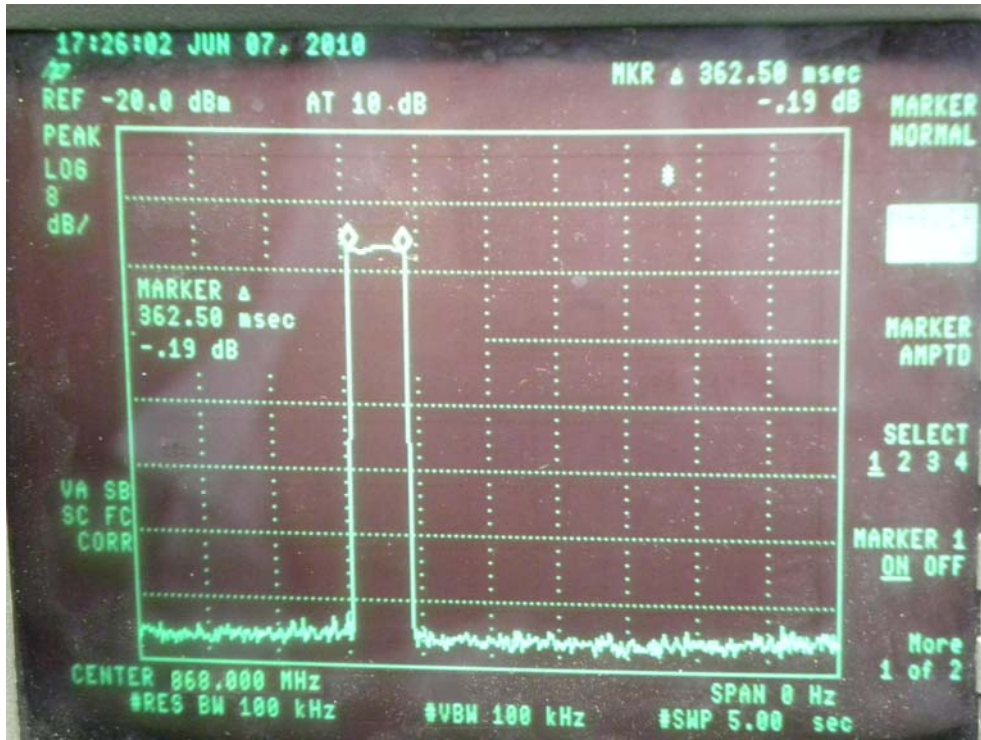

8. Occupied Bandwidth

8.1 Measurement Procedure

1. The EUT was placed on a turn table which is 0.8m above ground plane.
2. Set EUT as normal operation
3. Set SPA Center Frequency = fundamental frequency, RBW=10KHz, VBW= 30KHz
4. Set SPA Max hold. Mark peak.

8.2 Test SET-UP (Block Diagram of Configuration)

Same as 6.2 Radiated Emission Measurement.

8.3 Measurement Equipment Used:

Same as 6.2 Radiated Emission Measurement.

8.4 Measurement Results:

The field strength of any emissions which appear outside of this band shall not exceed the general radiated emission limits in section 15.209.

Refer to attached data chart.

20dB Bandwidth	Limit (Fundamental*0.25%)	Result
970KHz	$868\text{MHz} * 0.25\% = 2170\text{KHz}$	PASS

Band Width Test Data

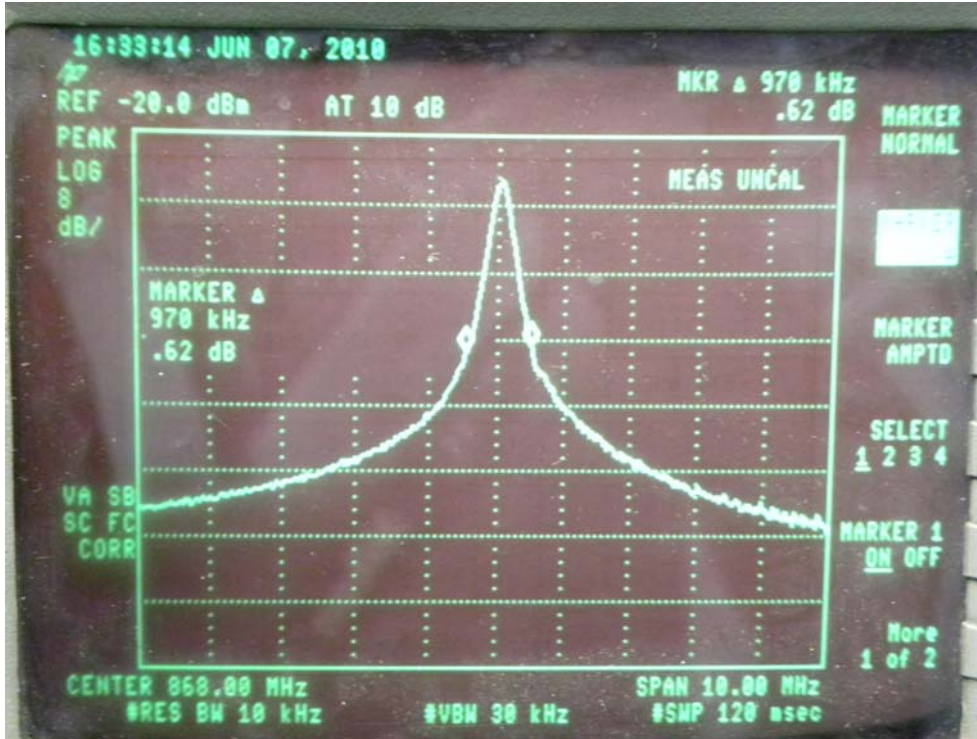

APPENDIX 1

PHOTOGRAPHS OF SET UP

Radiated Emission Setup Photos

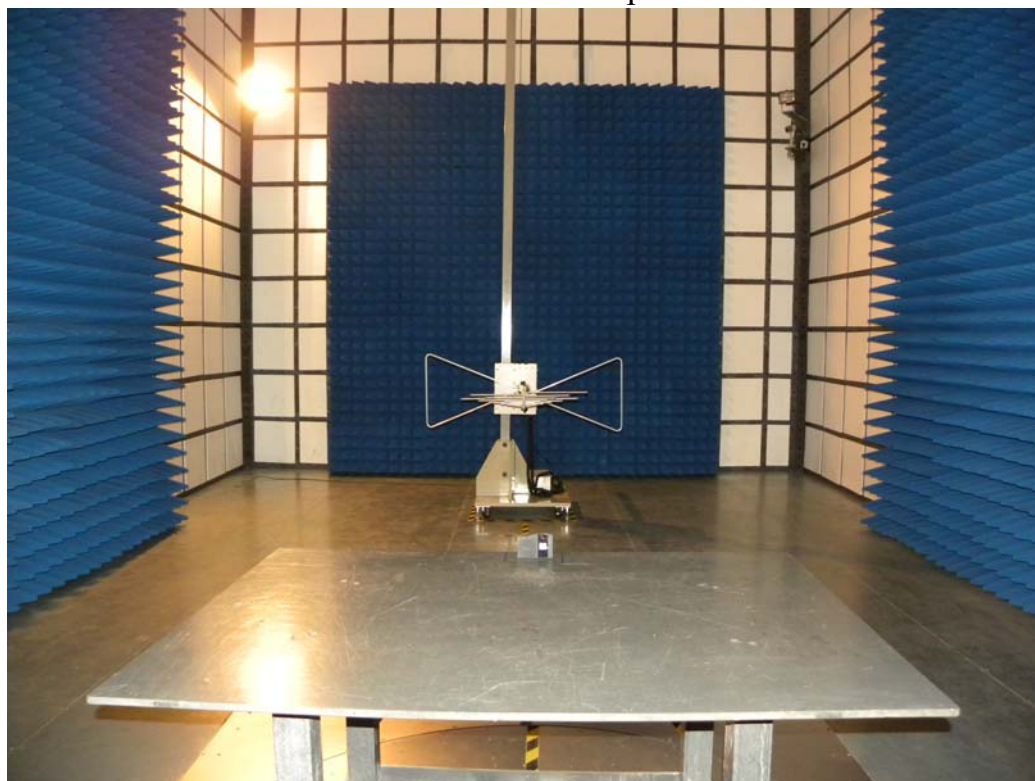

General Appearance of the EUT



