

3D G-Sensor

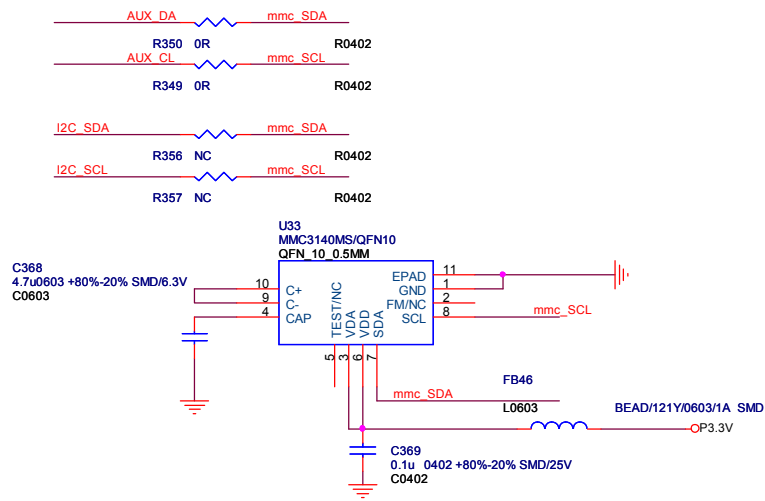

Far from Speaker, >50mm
Far from Power line, >10mm

Magnetic Sensor

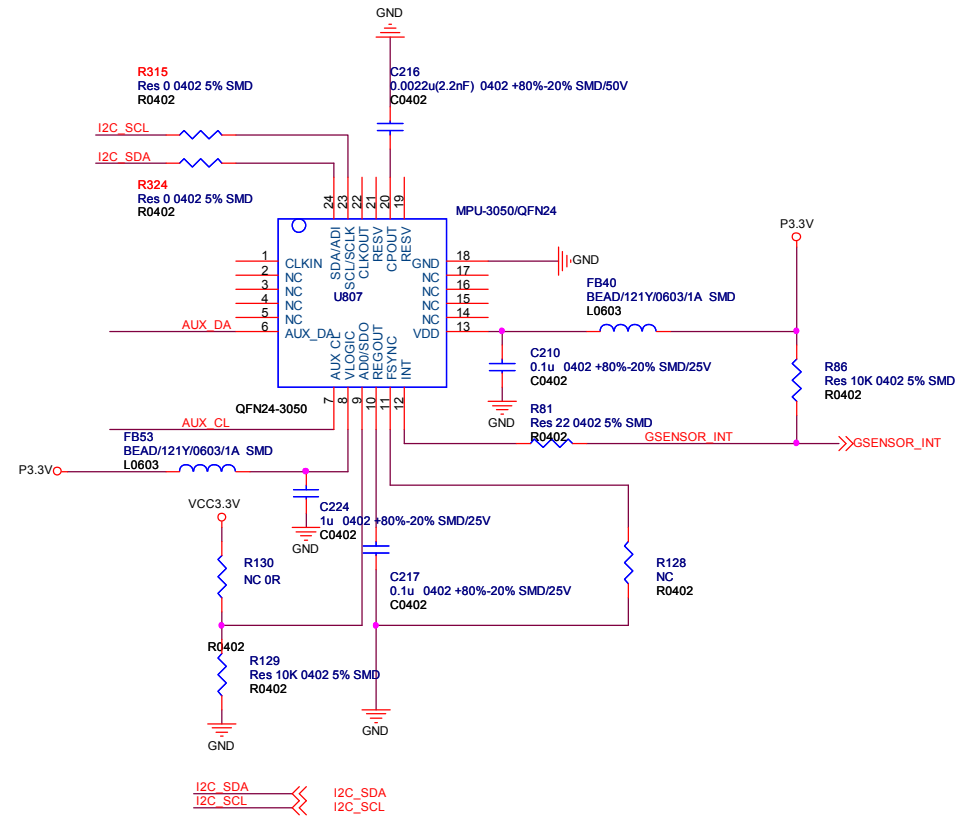

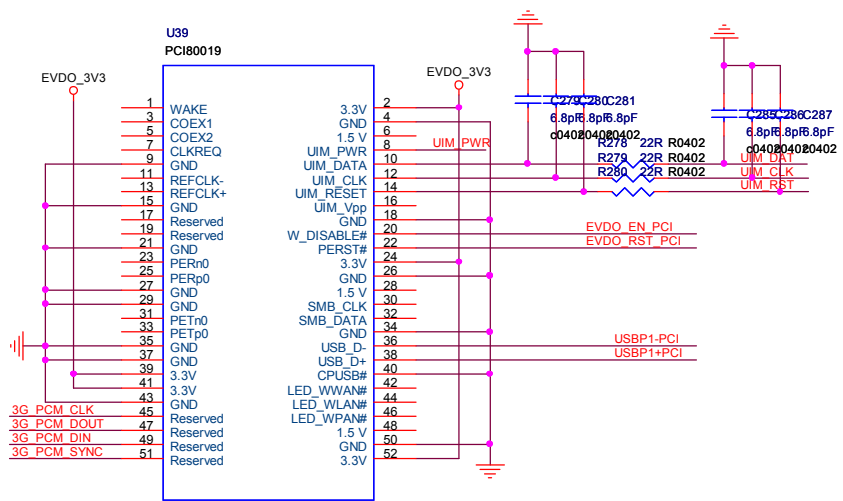

3G module EM660C work about power:
 Strong signal 300-400mA @ 3V3
 If the signal is 500-800mA @ 3V3

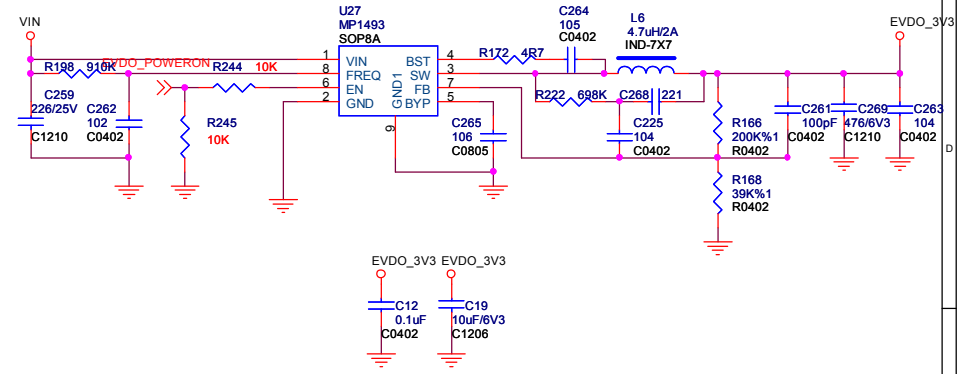
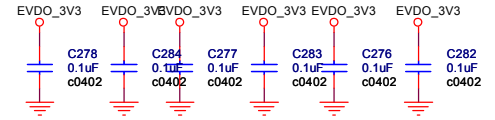

- R254 Res 1K 0402 5% SMD R0402
EVDO_EN_PCI <-> EVDO_EN
- R257 Res 1K 0402 5% SMD R0402
EVDO_RST_PCI <-> EVDO_RST
- R74 Res 0 0402 5% SMD R0402
USBP1-PCI <-> USB11_DM
- R80 Res 0 0402 5% SMD R0402
USBP1+PCI <-> USB11_DP
- EVDO_POWERON <-> EVDO_POWERON
- R138 Res 0 0402 5% SMD R0402
3G_PCM_CLK <-> I2S_SCLK
- R139 Res 0 0402 5% SMD R0402
3G_PCM_DOUT <-> I2S_DIN
- R140 Res 0 0402 5% SMD R0402
3G_PCM_DIN <-> I2S_DOUT
- R141 Res 0 0402 5% SMD R0402
3G_PCM_SYNC <-> I2S_LRCK
- SIM_IN <-> SIM_IN

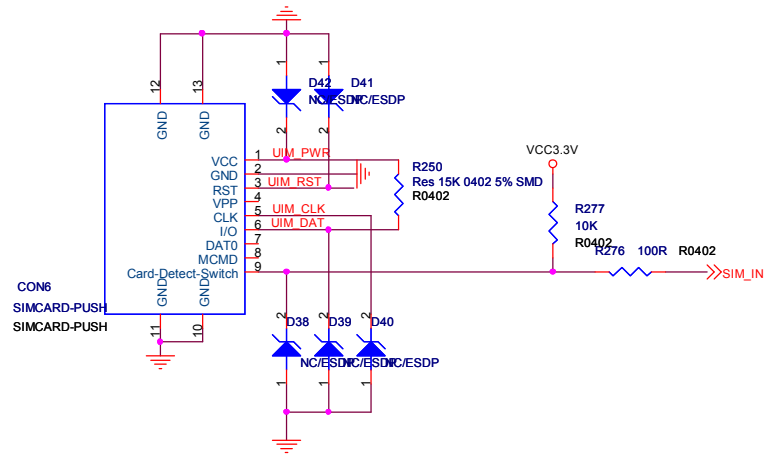

Title	<Title>	
Size	Document Number	Rev
B	<Doc>	<RevCode>
Date:	Thursday, June 09, 2011	Sheet 1 of 1

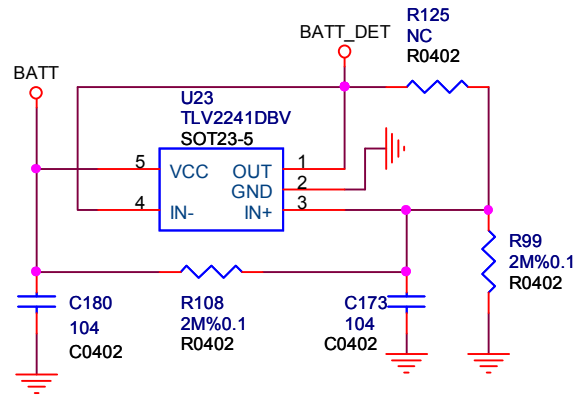
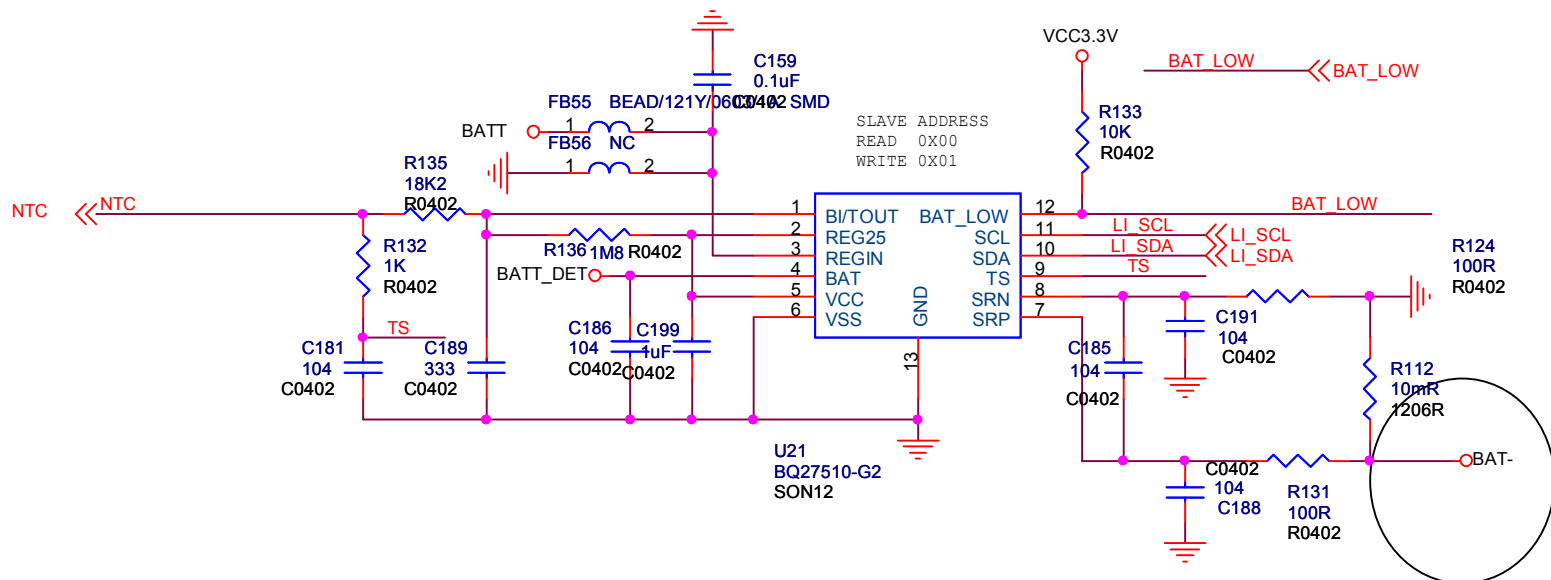

BATTER DET

Title		
<Title>		
Size	Document Number	Rev
A	<Doc>	<RevCode>
Date:	Wednesday, June 08, 2011	Sheet 1 of 1

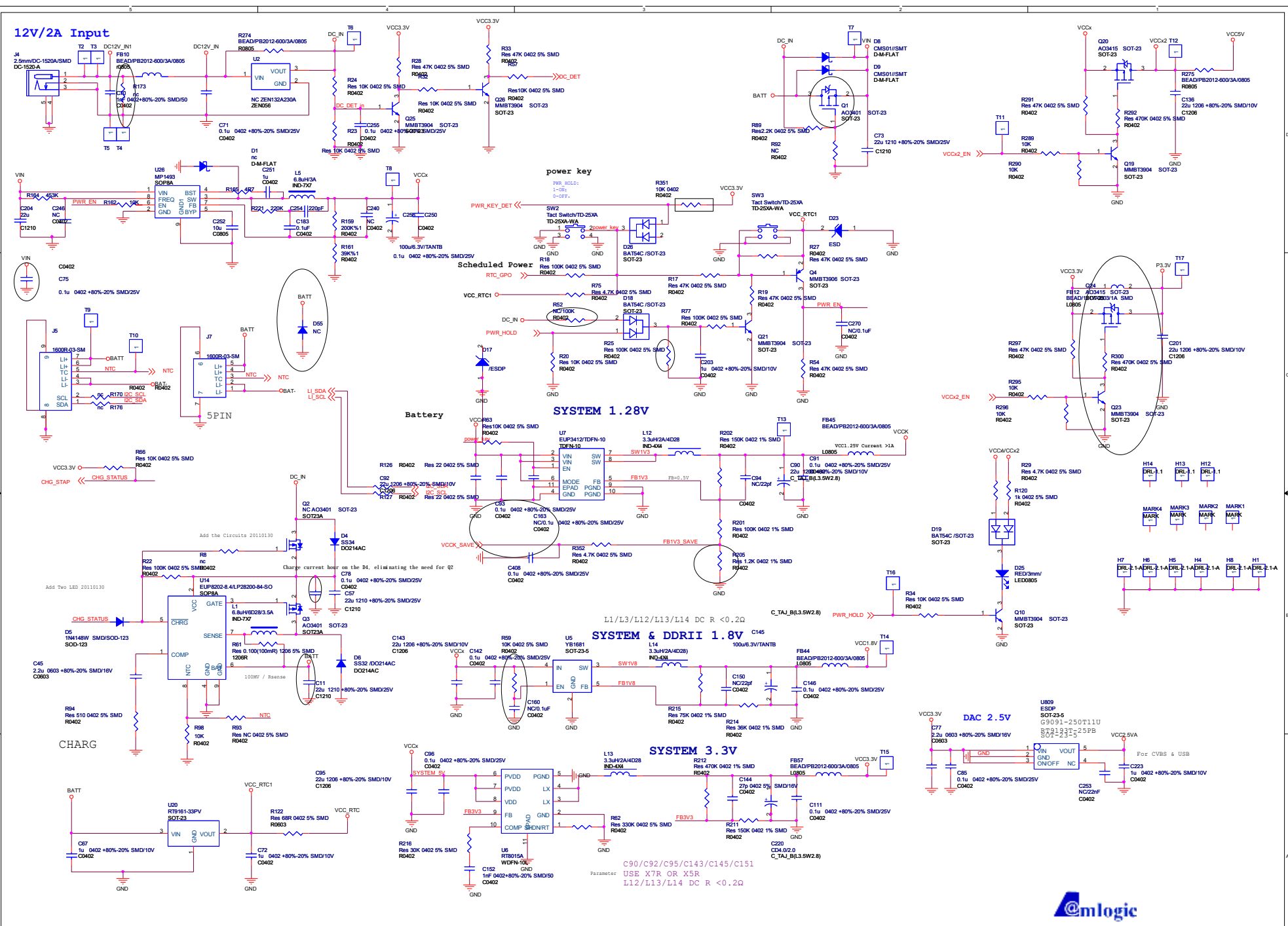

File	AML8726-M_MID	
Size	Document Number	Rev
C	Power	V0.5
Date	Tuesday, July 19, 2011	Sheet 2 of 10

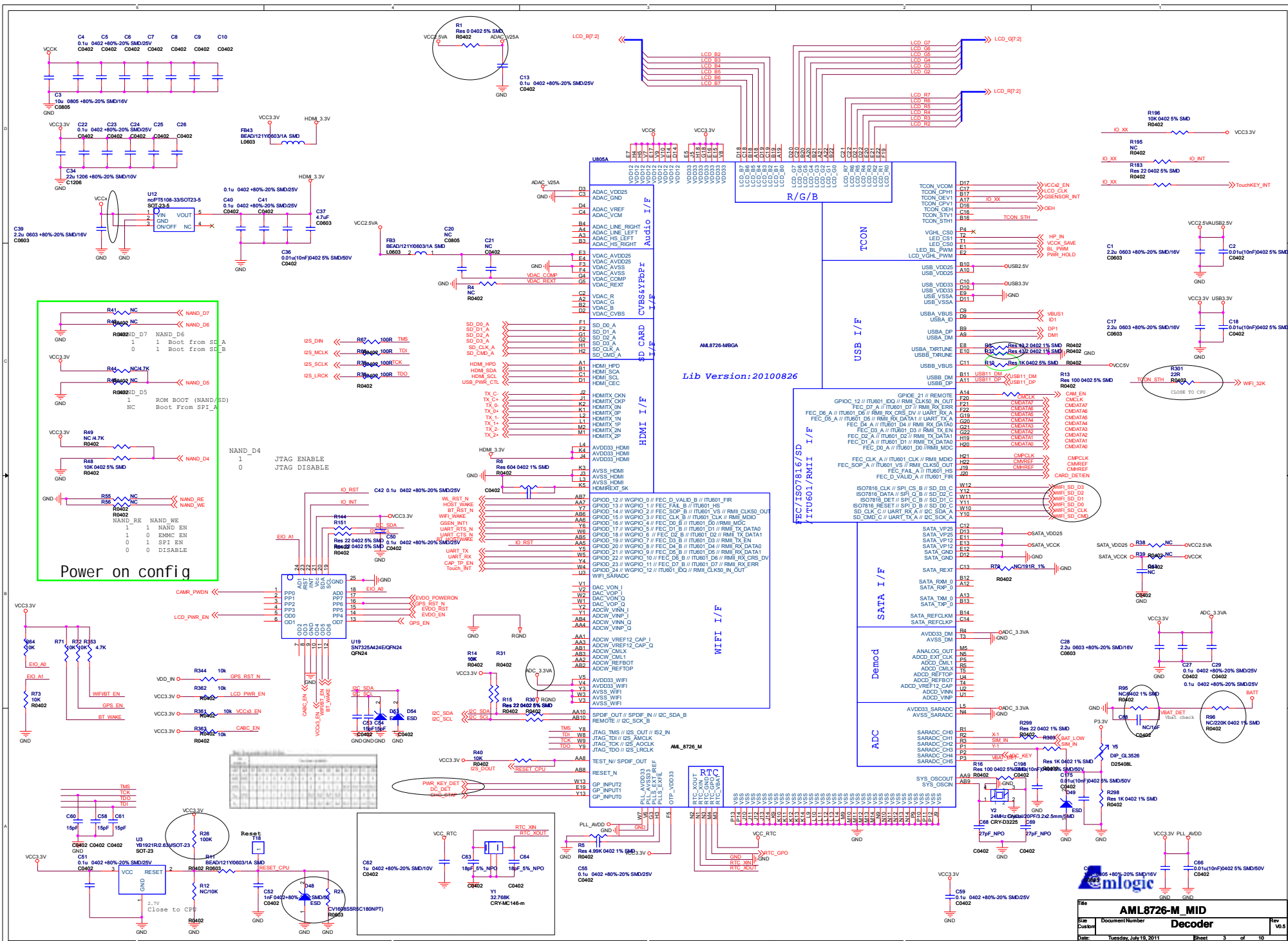

File	AML8726-M_MID
Doc	Document Number
Rev	1.0.5
Date	Tuesday, July 19, 2011
Sheet	3 of 10

Decoder

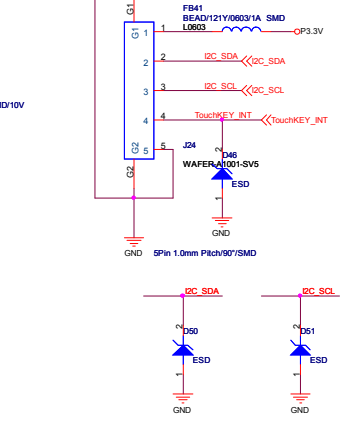
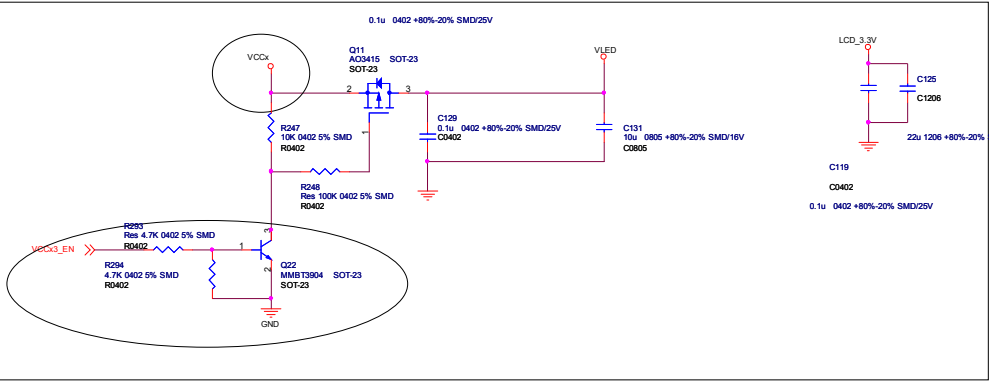
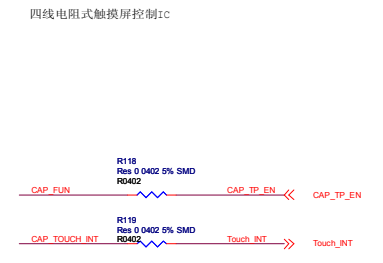
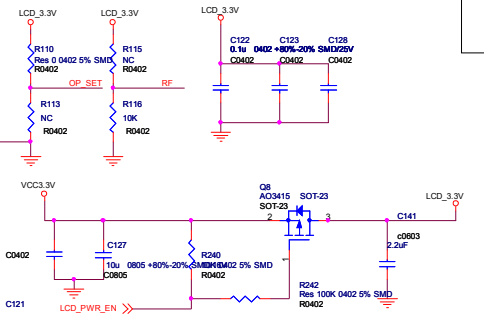
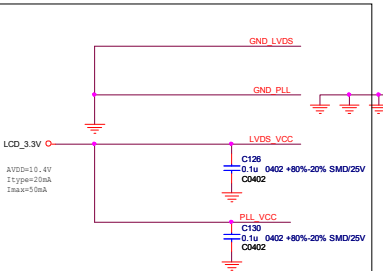
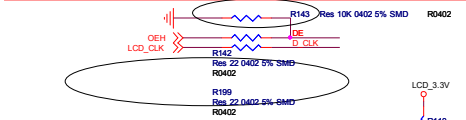
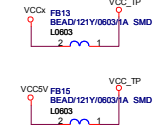
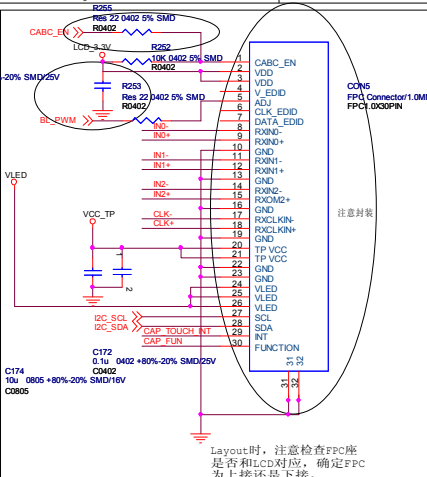
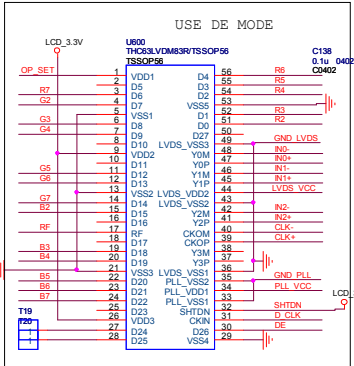
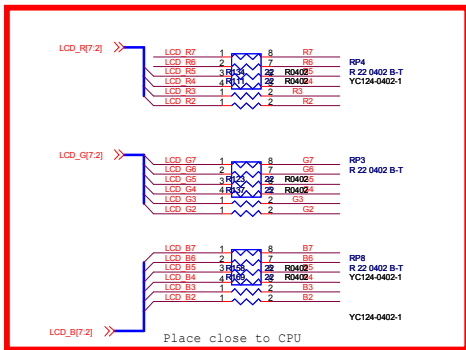

四线电阻式触摸屏控制ic

Layout时, 注意检查FPC座是否和LCD对应, 确定FPC为上接还是下接。



File	AML8726-M_MID		
Size	Document Number	New	
C	Panel	VO.5	
Date	Editer	June 17, 2011	Sheet 6 of 10

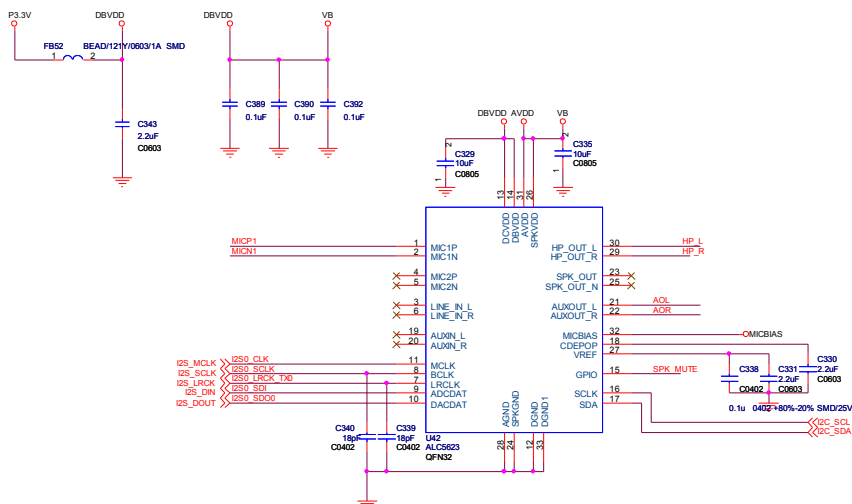

CODEC OPTION:REALTEK ALC5621

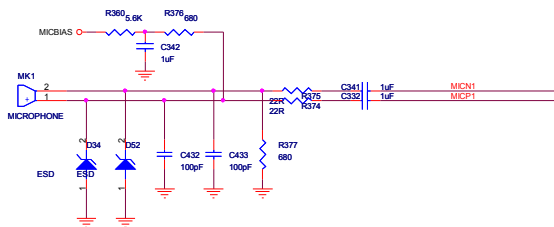

HEADPHONEC

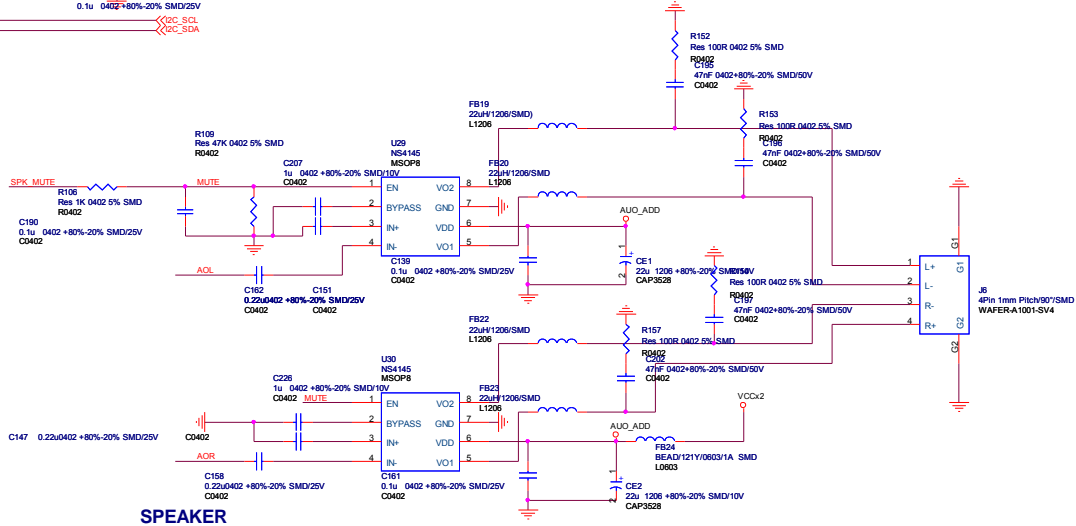
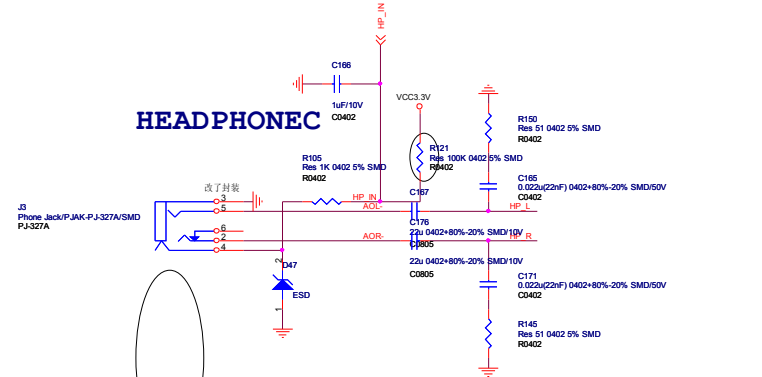

SPEAKER



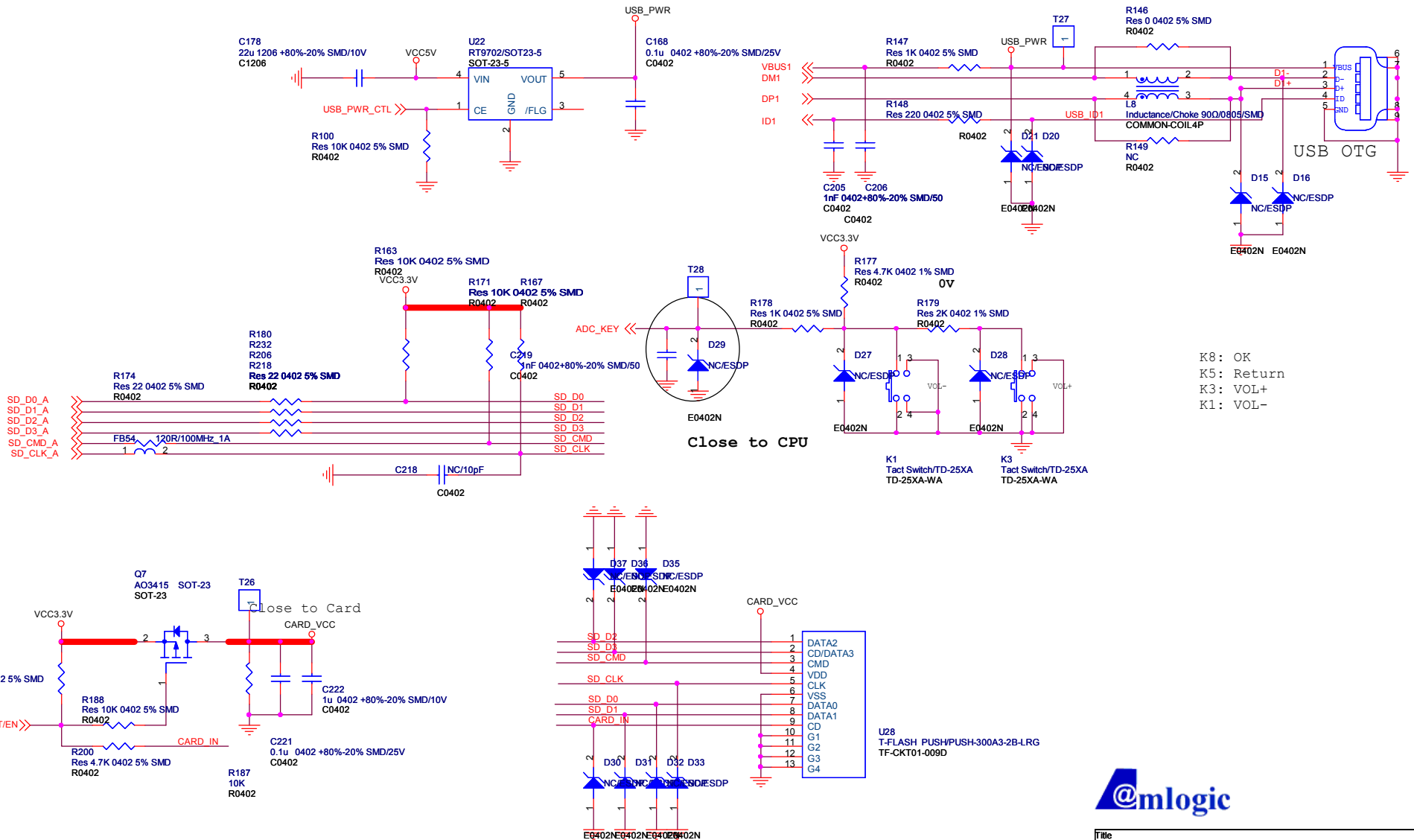

K8: OK
 K5: Return
 K3: VOL+
 K1: VOL-

Close to CPU

Close to Card



Title AML8726-M_MID		
Size B	Document Number Key & IR & USB & Card	Rev VO.5
Date: Friday, June 17, 2011	Sheet 7	of 10

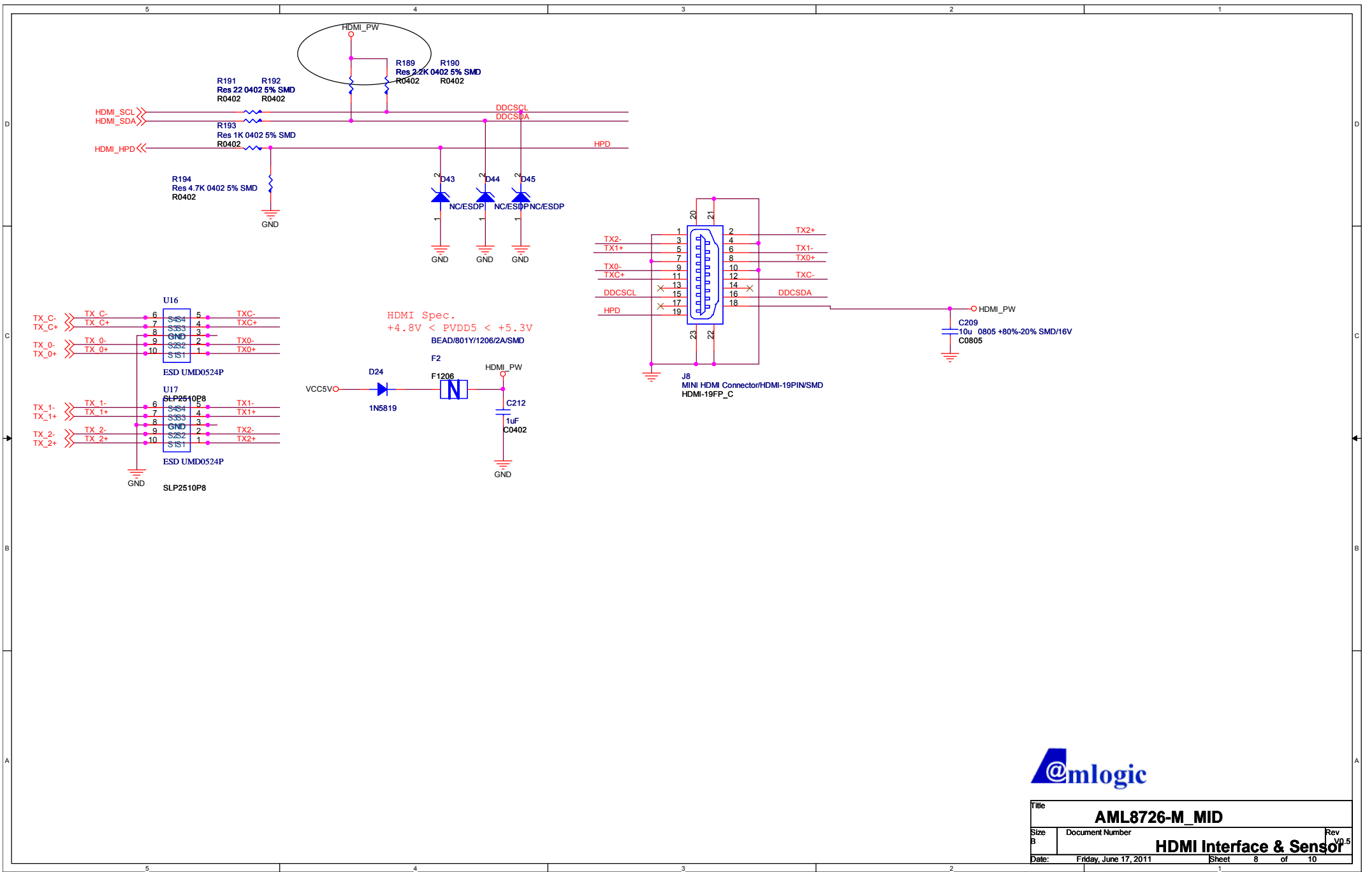

Title		AML8726-M_MID	
Size	Document Number	HDMI Interface & Sensor	
B			
Date:	Friday, June 17, 2011	Sheet	8 of 10
			1

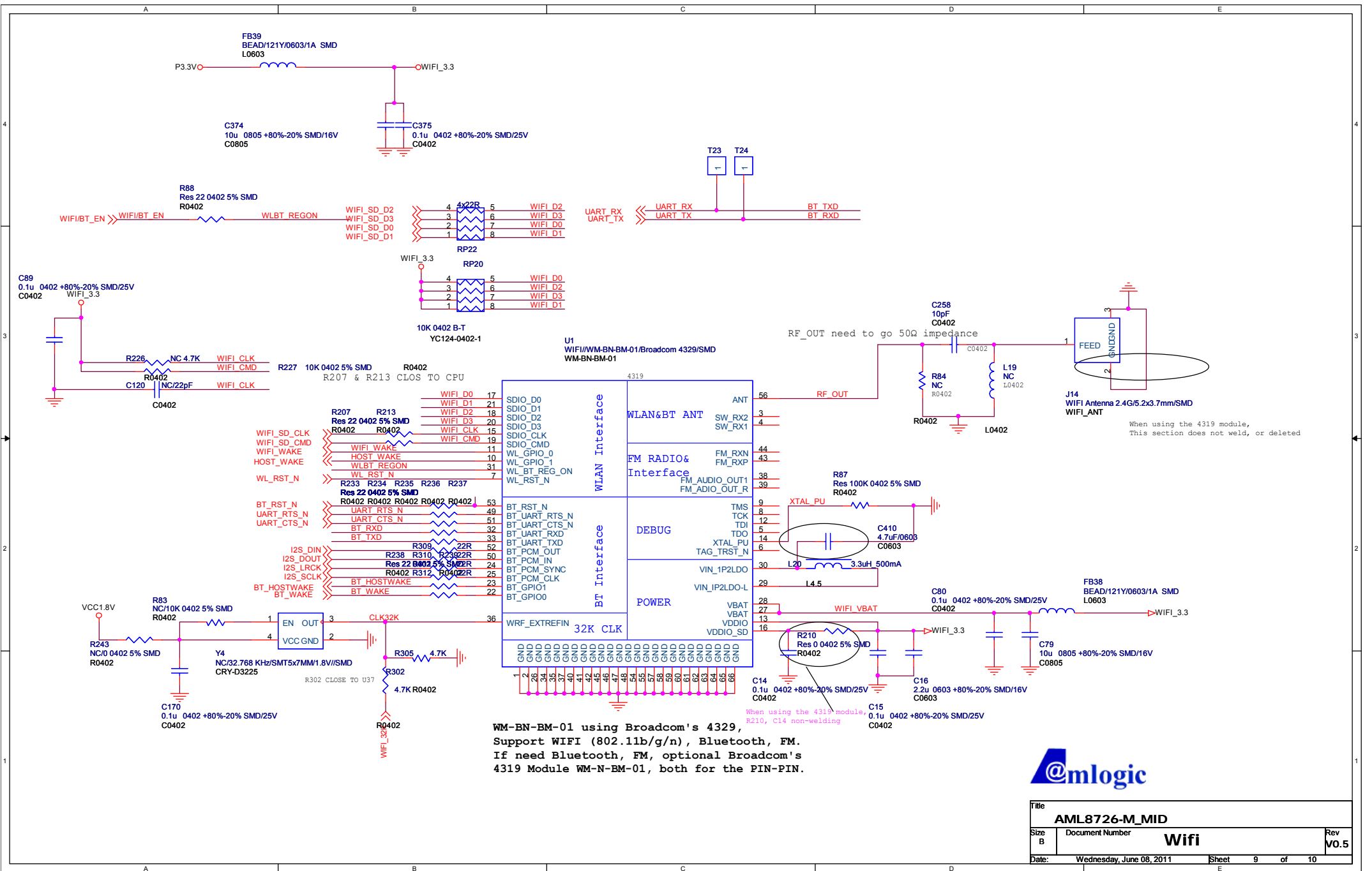

WM-BN-BM-01 using Broadcom's 4319,
 Support WIFI (802.11b/g/n), Bluetooth, FM.
 If need Bluetooth, FM, optional Broadcom's
 4319 Module WM-N-BM-01, both for the PIN-PIN.



Title		AML8726-M_MID	
Size	Document Number	Wifi	
B			Rev V0.5
Date:	Wednesday, June 08, 2011	Sheet	9 of 10

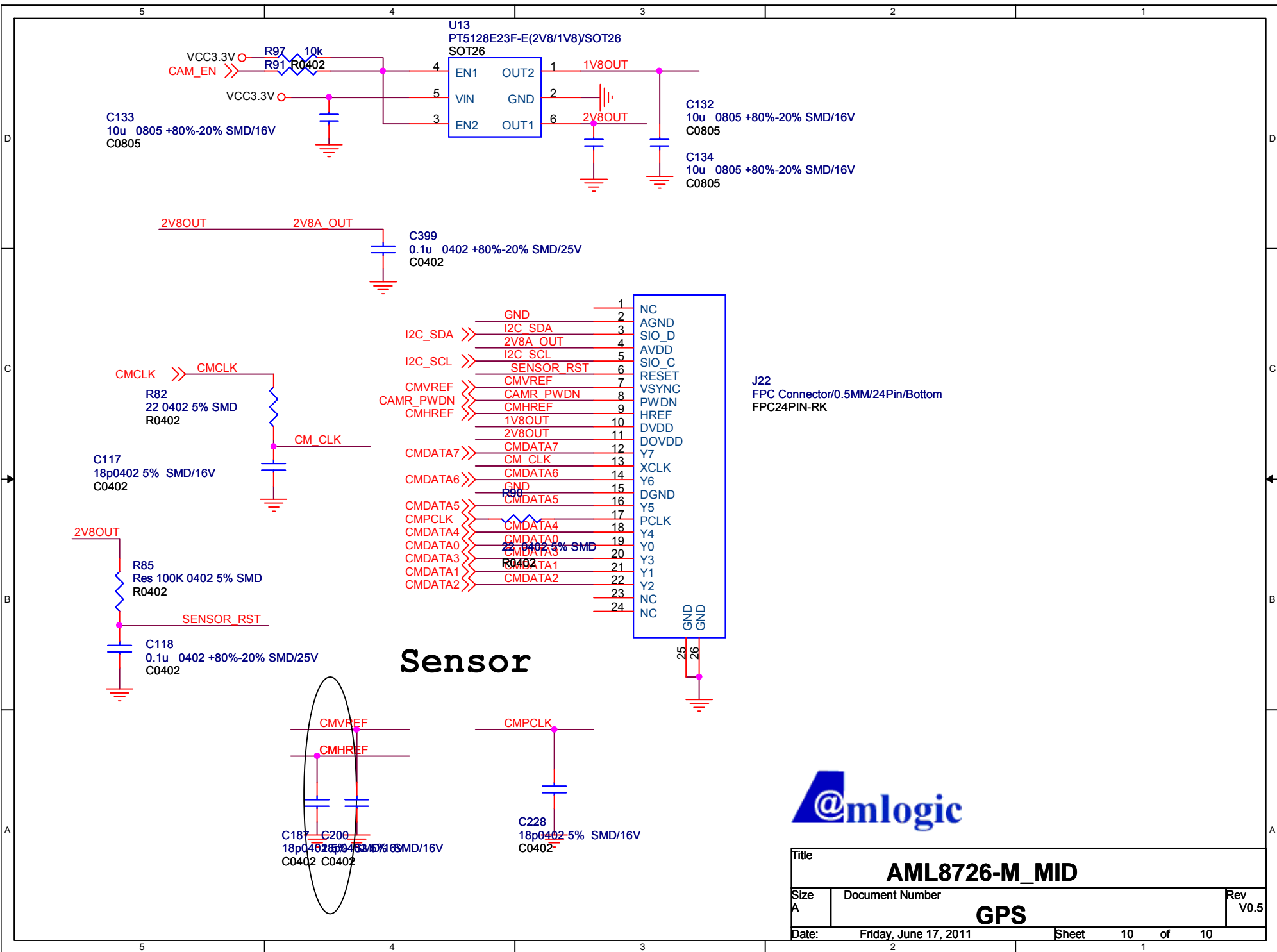

Title		
AML8726-M_MID		
Size	Document Number	Rev
A	GPS	V0.5
Date:	Friday, June 17, 2011	Sheet 10 of 10