



卓時檢測
TIMEWAY TESTING LABORATORY



ISO/IEC17025 Accredited Lab.

Report No: FCC 0904187
File reference No: 2009-04-29

Applicant: WIN ACCORD LTD.

Product: Digital Photo Frame

Brand Name: N/A

Model No: DF13301-05-XXX

Test Standards: FCC Part 15 Subpart B: 2008

Test result: It is herewith confirmed and found to comply with the requirements set up by ANSI C63.4&FCC Part 15 regulations for the evaluation of electromagnetic compatibility

Approved By
Jack Chung

Jack Chung

Manager

Dated: April 29, 2009

Results appearing herein relate only to the sample tested

The technical reports is issued errors and omissions exempt and is subject to withdrawal at

SHENZHEN TIMEWAY TECHNOLOGY CONSULTING CO LTD

East 5/Block 4, Anhua Industrial Zone, No.8, Tairan Rd. Chegongmiao, FuTian District, Shenzhen, CHINA.

Tel (755) 83448688 Fax (755) 83442996



Special Statement:

The testing quality ability of our laboratory meet with "Quality Law of People's Republic of China" Clause 19.

The testing quality system of our laboratory meet with ISO/IEC-17025 requirements, which is approved by CNAS. This approval result is accepted by MRA of APLAC.

Our test facility is recognized, certified, or accredited by the following organizations:

CNAS-LAB Code: L2292

The EMC Laboratory has been assessed and in compliance with CNAS-CL01 accreditation criteria for testing Laboratories (identical to ISO/IEC 17025:2005 General Requirements) for the Competence of testing Laboratories.

FCC-Registration No.: 899988

The EMC Laboratory has been registered and fully described in a report filed with the (FCC) Federal Communications commission. The acceptance letter from the FCC is maintained in our files. Registration No.: 899988.

IC- Registration No.: IC5205A-01

The EMC Laboratory has been registered and fully described in a report filed with the (IC) Industry Canada. The acceptance letter from the IC is maintained in our files. Registration IC No.: 5205A-01.

The report refers only to the sample tested and does not apply to the bulk.

This report is issued in confidence to the client and it will be strictly treated as such by the Shenzhen Timeway Technology Consulting Co., Ltd. It may not be reproduced rather in its entirety or in part and it may not be used for adverting. The client to whom the report is issued may, however, show or send it . or a certified copy there of prepared by the Shenzhen Timeway Technology Consulting co., Ltd to his customer. Supplier or others persons directly concerned. Shenzhen Timeway Technology Consulting co., Ltd will not, without the consent of the client enter into any discussion of correspondence with any third party concerning the contents of the report.

In the event of the improper use of the report. The Shenzhen Timeway Technology Consulting co., Ltd reserves the rights to withdraw it and to adopt any other remedies which may be appropriate.



Test Report Conclusion
Content

1.0	General Details	4
1.1	Test Lab Details.....	4
1.2	Applicant Details.....	4
1.3	Description of EUT	4
1.4	Test Uncertainty.....	4
1.5	Submitted Sample.....	4
1.6	Test Duration.....	4
2.0	List of Measurement Equipment	5
2.1	Conducted Emission Test.....	5
2.2	Radiated electromagnetic disturbance test.....	5
2.3	Auxiliary Equipment.....	5
3.0	Technical Details	6
3.1	Investigations Requested.....	6
3.2	Test Standards.....	6
4.0	Power line Conducted Emission Test	7
5.0	Radiated Disturbance Test	29
6.0	FCC ID Label	51
7.0	Photo of testing	52

The report refers only to the sample tested and does not apply to the bulk.

This report is issued in confidence to the client and it will be strictly treated as such by the Shenzhen Timeway Technology Consulting Co., Ltd. It may not be reproduced rather in its entirety or in part and it may not be used for advertising. The client to whom the report is issued may, however, show or send it or a certified copy thereof prepared by the Shenzhen Timeway Technology Consulting Co., Ltd to his customer. Supplier or other persons directly concerned. Shenzhen Timeway Technology Consulting Co., Ltd will not, without the consent of the client enter into any discussion of correspondence with any third party concerning the contents of the report.

In the event of the improper use of the report. The Shenzhen Timeway Technology Consulting Co., Ltd reserves the rights to withdraw it and to adopt any other remedies which may be appropriate.



1.0 General Details

1.1 Test Lab Details

Name : SHENZHEN TIMEWAY TECHNOLOGY CONSULTING CO LTD
Address: East 5/Block 4, Anhua Industrial Zone, No.8,Tairan Rd. CheGongMiao, FuTian District, Shenzhen, CHINA.
Telephone: (755) 83448688
Fax: (755) 83442996

1.2 Applicant Details

Applicant: WIN ACCORD LTD.
Address: 12F, NO.225, SEC 5, 105 SONG SHAN DIST., NAN JING EAST ROAD, TAIPEI, TAIWAN
Telephone: 02-2749 3837
Fax: 02-2749-3918

1.3 Description of EUT

Product: Digital Photo Frame
Manufacturer: WIN ACCORD LTD.
Address: 12F, NO.225, SEC 5, 105 SONG SHAN DIST., NAN JING EAST ROAD, TAIPEI, TAIWAN
Brand Name: N/A
Model Number: DF13301-05-XXX (X=A-Z, 0-9, a-z)
Additional Model Number: DW133xxx
The adapter Model No.: XKD-C1500IC12.0-18C-US (Made by MOSO)
Rating: Input: 100-240V, 0.7A Max, 50/60Hz Output: 12V, 1.5A
The adapter Model No.: ADS-18C-12N 12018GPCU (Made by HONOR)
Rating: Input: 100-240V, 0.6A Max, 50/60Hz Output: 12V, 1.5A
Remark: Just model names and appearance color are different.
Rating: Input: DC 12V, Current 1.5A

1.4 Submitted Sample(s): 1 Sample

1.5 Test Duration: 2009-04-23 to 2009-04-29

1.6 Test Uncertainty

Conducted Emissions Uncertainty =3.6dB
Radiated Emissions Uncertainty =4.7dB

The report refers only to the sample tested and does not apply to the bulk.

This report is issued in confidence to the client and it will be strictly treated as such by the Shenzhen Timeway Technology Consulting Co., Ltd. It may not be reproduced rather in its entirety or in part and it may not be used for advertising. The client to whom the report is issued may, however, show or send it or a certified copy thereof prepared by the Shenzhen Timeway Technology Consulting Co., Ltd to his customer. Supplier or other persons directly concerned. Shenzhen Timeway Technology Consulting Co., Ltd will not, without the consent of the client enter into any discussion of correspondence with any third party concerning the contents of the report.

In the event of the improper use of the report. The Shenzhen Timeway Technology Consulting Co., Ltd reserves the rights to withdraw it and to adopt any other remedies which may be appropriate.



1.7 Test Engineer

The sample tested by

Print Name: Terry Tang

2.0 List of Measurement Equipment

2.1 Conducted Emission Test

Name	Model No.	Serial No.	Manufacturer	Calibration Date	Calibration Cycle
EMI Test Receiver	ESCS30	830245/009	RS	2009.2.23	1Year
Coaxial Switch	MP59B	M70585	ANRITSU	N/A	N/A
LISN	NTFM8132	8132137	SCHWARZBECK	2009.2.24	1Year
LISN	NTFM8134	8134109	SCHWARZBECK	2009.2.24	1Year
LISN	NTFM8136	8136102	SCHWARZBECK	2009.2.24	1Year

2.2 Radiated electromagnetic disturbance test

Name	Model No.	Serial No.	Manufacturer	Calibration Date	Calibration Cycle
EMI Test Receiver	ESCS30	830245/009	RS	2009.2.23	1Year
Coaxial Switch	MP59B	M70585	ANRITSU	N/A	N/A
Spectrum Analyzer(with Tracking Generator)	MS2661C	MT72089	ANRITSU	2009.2.23	1Year
Amplifier	MH648A	M20494	ANRITSU	2009.2.24	1Year
Bilog Antenna	CBL6101C	2576	CHASE	2009.2.23	1Year

2.3 Auxiliary Equipment

Name	Model No.	Serial No.	Manufacturer	Cable	FCC ID/DOC
Keyboard	KB-0225	1211815	IBM	Data cable of 2m length unshielded	FCC DOC
Printer	LaserJet 1015	CNFG029476	HP	Data cable of 2m length unshielded and 1.8m length AC Mains cable	DOC

The report refers only to the sample tested and does not apply to the bulk.

This report is issued in confidence to the client and it will be strictly treated as such by the Shenzhen Timeway Technology Consulting Co., Ltd. It may not be reproduced rather in its entirety or in part and it may not be used for advertizing. The client to whom the report is issued may, however, show or send it . or a certified copy there of prepared by the Shenzhen Timeway Technology Consulting co., Ltd to his customer. Supplier or others persons directly concerned. Shenzhen Timeway Technology Consulting co., Ltd will not, without the consent of the client enter into any discussion of correspondence with any third party concerning the contents of the report.

In the event of the improper use of the report. The Shenzhen Timeway Technology Consulting co., Ltd reserves the rights to withdraw it and to adopt any other remedies which may be appropriate.



Printer	LaserJet 1022	CN BG591GM7	HP	Data cable of 2m length unshielded and 1.8m length AC Mains cable	DOC
Monitor	FP51G	ET47604175CLO	BENQ	Data cable of 1.5m length unshielded and 1.8m length AC Mains cable	FCC DOC
Monitor	6331-4CN	23-DNWX3	IBM	Data cable of 1.5m length unshielded and 1.8m length AC Mains cable	FCC DOC

PC	8434	--	IBM	1.8m length AC Mains cable	FCC DOC
Mouse	M-F105	--	S.SElectron	Data cable of 1.5m length	FCC DOC

3.0 Technical Details

3.1 Investigations Requested

Perform Electromagnetic Interference [EMI] tests for FCC Requirement.

3.2 Test Standards

FCC Part 15 Subpart B: 2008

The report refers only to the sample tested and does not apply to the bulk.

This report is issued in confidence to the client and it will be strictly treated as such by the Shenzhen Timeway Technology Consulting Co., Ltd. It may not be reproduced in its entirety or in part and it may not be used for advertising. The client to whom the report is issued may, however, show or send it or a certified copy thereof prepared by the Shenzhen Timeway Technology Consulting Co., Ltd to his customer. Supplier or other persons directly concerned. Shenzhen Timeway Technology Consulting Co., Ltd will not, without the consent of the client enter into any discussion of correspondence with any third party concerning the contents of the report.

In the event of the improper use of the report. The Shenzhen Timeway Technology Consulting Co., Ltd reserves the rights to withdraw it and to adopt any other remedies which may be appropriate.



4.0 Conducted Power line Test

4.1 Schematics of the test

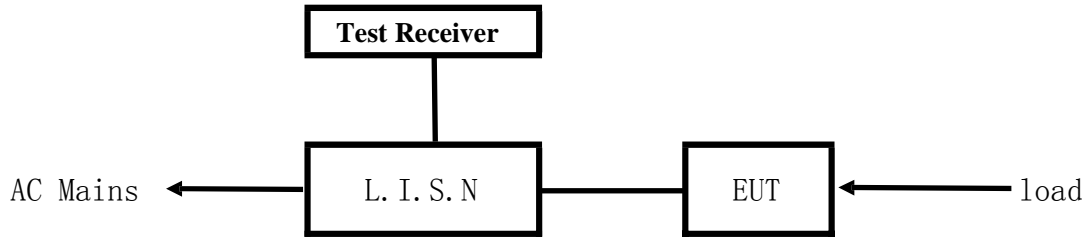

EUT: Equipment Under Test

4.2 Test Method and test Procedure

The EUT was tested according to ANSI C63.4-2003. The Frequency spectrum From 0.15MHz to 30MHz was investigated. The LISN used was 50ohm/50uH as specified by section 5.1 of ANSI C63.4-2003. Cables and peripherals were moved to find the maximum emission levels for each frequency.

Block diagram of Test setup

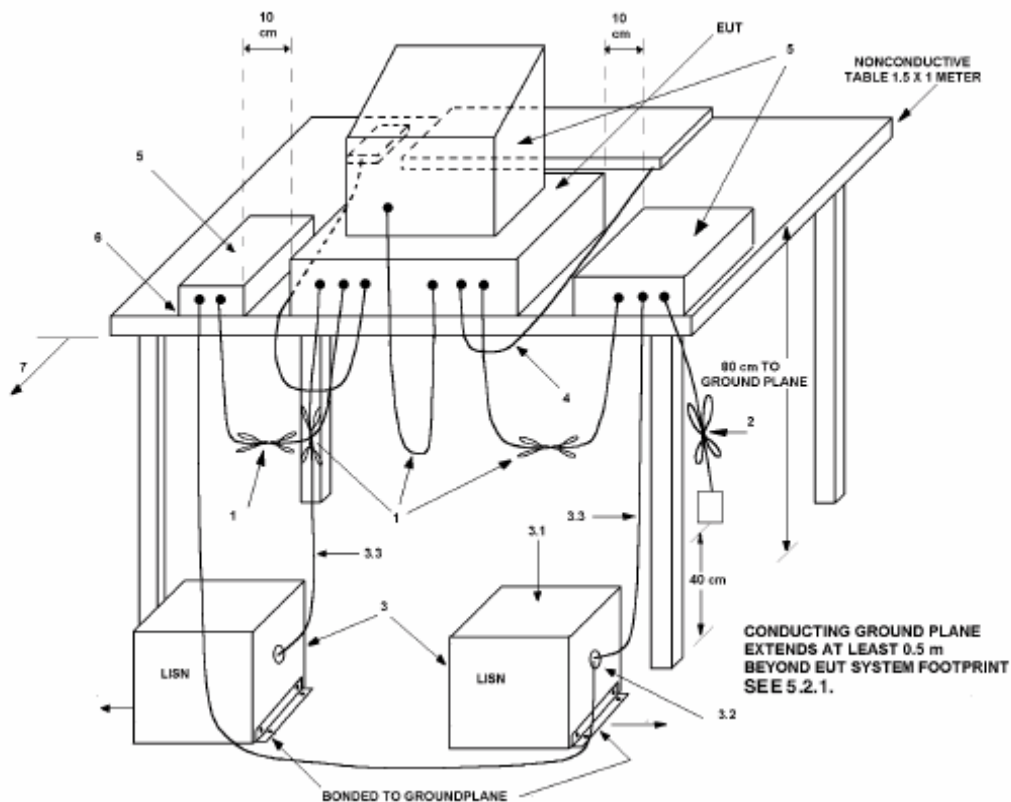

The report refers only to the sample tested and does not apply to the bulk.

This report is issued in confidence to the client and it will be strictly treated as such by the Shenzhen Timway Technology Consulting Co., Ltd. It may not be reproduced in its entirety or in part and it may not be used for advertising. The client to whom the report is issued may, however, show or send it, or a certified copy thereof prepared by the Shenzhen Timway Technology Consulting Co., Ltd to his customer. Supplier or other persons directly concerned. Shenzhen Timway Technology Consulting Co., Ltd will not, without the consent of the client enter into any discussion of correspondence with any third party concerning the contents of the report.

In the event of the improper use of the report. The Shenzhen Timway Technology Consulting Co., Ltd reserves the rights to withdraw it and to adopt any other remedies which may be appropriate.



4.3 Power line conducted Emission Limit

Frequency(MHz)	Class A Limits dB(μ V)		Class B Limits dB(μ V)	
	Quasi-peak Level	Average Level	Quasi-peak Level	Average Level
0.15 ~ 0.50	79.00	66.00	66.00~56.00*	56.00~46.00*
0.50 ~ 5.00	73.00	60.00	56.00	46.00
5.00 ~ 30.00	73.00	60.00	60.00	50.00

- Notes: 1. *decreasing linearly with logarithm of frequency.
2. The tighter limit shall apply at the transition frequencies

4.4 Test Results

The frequency spectrum from 0.15MHz to 30MHz was investigated. All reading are quasi-peak values with a resolution bandwidth of 9kHz.



A: Conducted Emission on Line Terminal of the power line (150kHz to 30MHz)

EUT set Condition: Memory
 Adaptor used for test Model No.: ADS-18C-12N 12018GPCU
 Working Voltage: 120V~ 60Hz

Results: Pass

Please refer to following diagram for individual

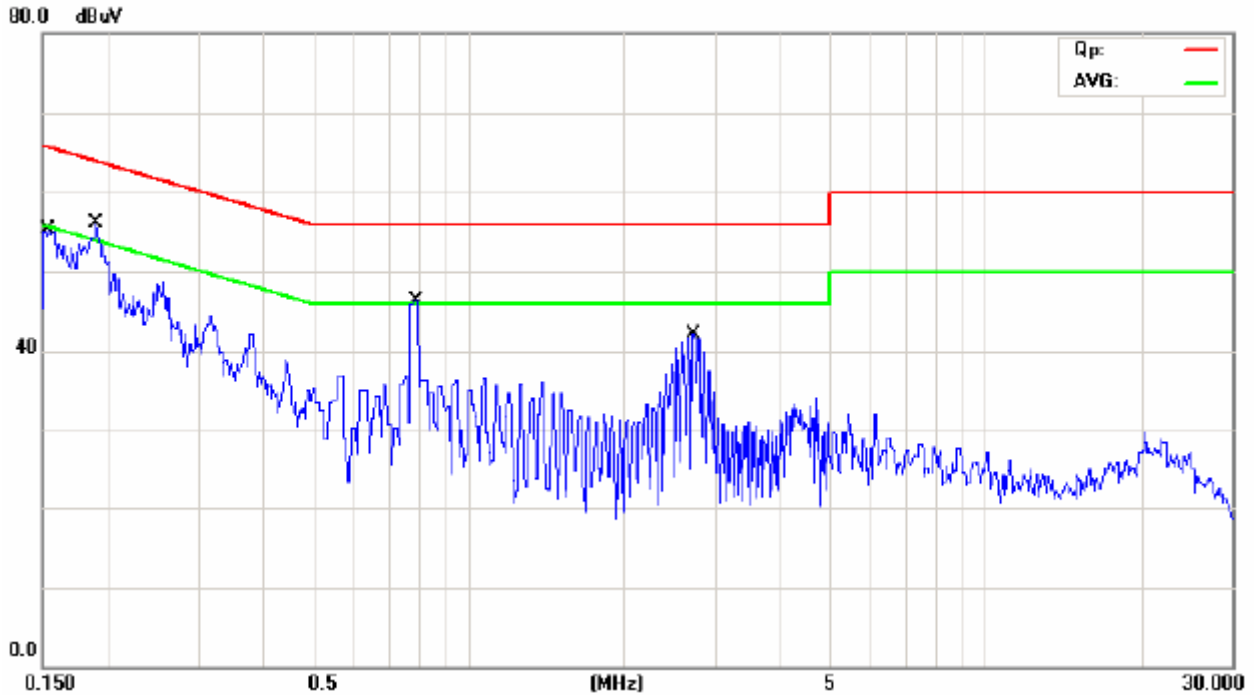

Frequency (MHz)	Reading(dB μ V)				Limit (dB μ V)	
	Live		Neutral		Quasi-peak Average	
	Quasi-peak	Average	Quasi-peak	Average		
0.153	42.30	4.30	--	--	65.83	55.83
0.188	49.74	33.34	--	--	64.12	54.12
0.790	41.38	36.88	--	--	56.00	46.00
2.714	34.49	32.39	--	--	60.00	50.00

The report refers only to the sample tested and does not apply to the bulk.
 This report is issued in confidence to the client and it will be strictly treated as such by the Shenzhen Timeway Technology Consulting Co., Ltd. It may not be reproduced in its entirety or in part and it may not be used for advertising. The client to whom the report is issued may, however, show or send it, or a certified copy thereof prepared by the Shenzhen Timeway Technology Consulting Co., Ltd to his customer. Supplier or other persons directly concerned. Shenzhen Timeway Technology Consulting Co., Ltd will not, without the consent of the client enter into any discussion of correspondence with any third party concerning the contents of the report.
 In the event of the improper use of the report. The Shenzhen Timeway Technology Consulting Co., Ltd reserves the rights to withdraw it and to adopt any other remedies which may be appropriate.



B: Conducted Emission on Neutral Terminal of the power line (150kHz to 30MHz)

EUT set Condition: Memory
 Adaptor used for test Model No.: ADS-18C-12N 12018GPCU
 Working Voltage: 120V~ 60Hz

Results: Pass

Please refer to following diagram for individual

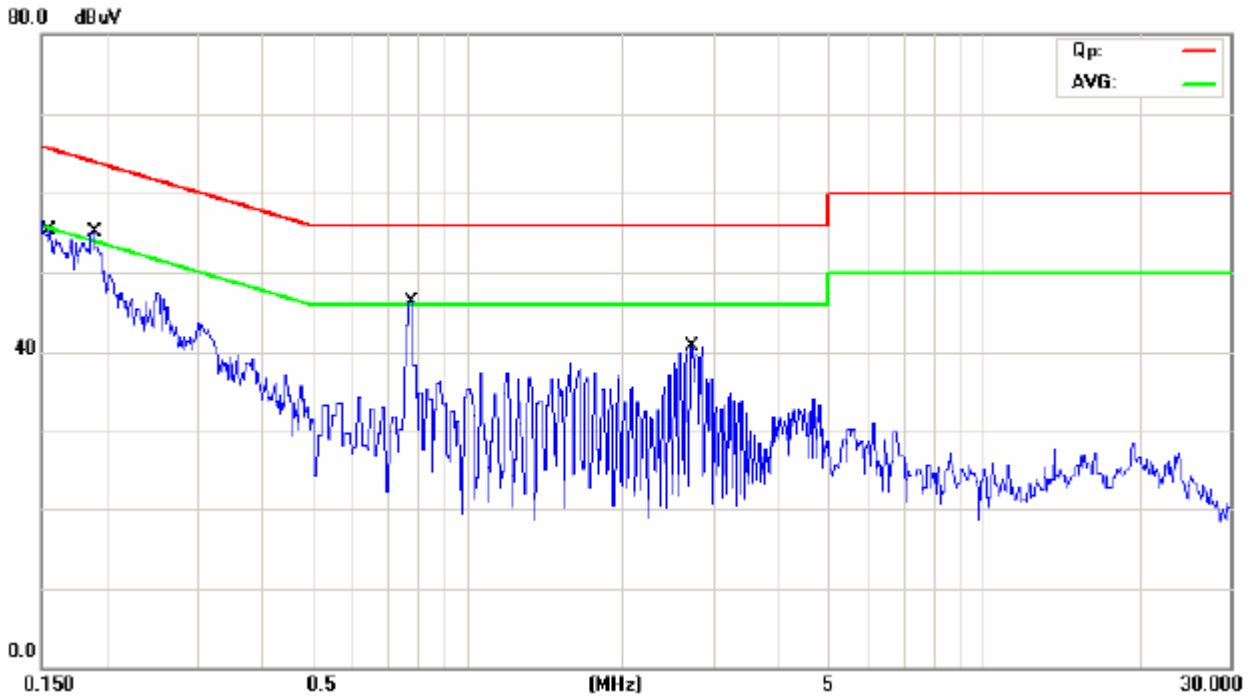

Frequency (MHz)	Reading(dB µ V)				Limit (dB µ V)	
	Live		Neutral		Quasi-peak	Average
	Quasi-peak	Average	Quasi-peak	Average		
0.153	--	--	42.50	3.30	65.84	55.84
0.188	--	--	49.24	33.64	64.10	54.10
0.777	--	--	41.96	36.16	56.00	46.00
2.716	--	--	35.09	30.99	50.00	60.00

The report refers only to the sample tested and does not apply to the bulk.
 This report is issued in confidence to the client and it will be strictly treated as such by the Shenzhen Timeway Technology Consulting Co., Ltd. It may not be reproduced rather in its entirety or in part and it may not be used for advertising. The client to whom the report is issued may, however, show or send it . or a certified copy there of prepared by the Shenzhen Timeway Technology Consulting co., Ltd to his customer. Supplier or others persons directly concerned. Shenzhen Timeway Technology Consulting co., Ltd will not, without the consent of the client enter into any discussion of correspondence with any third party concerning the contents of the report.
 In the event of the improper use of the report. The Shenzhen Timeway Technology Consulting co., Ltd reserves the rights to withdraw it and to adopt any other remedies which may be appropriate.



C: Conducted Emission on Line Terminal of the power line (150kHz to 30MHz)

EUT set Condition: Play SD
 Adaptor used for test Model No.: ADS-18C-12N 12018GPCU
 Working Voltage: 120V~ 60Hz

Results: Pass

Please refer to following diagram for individual

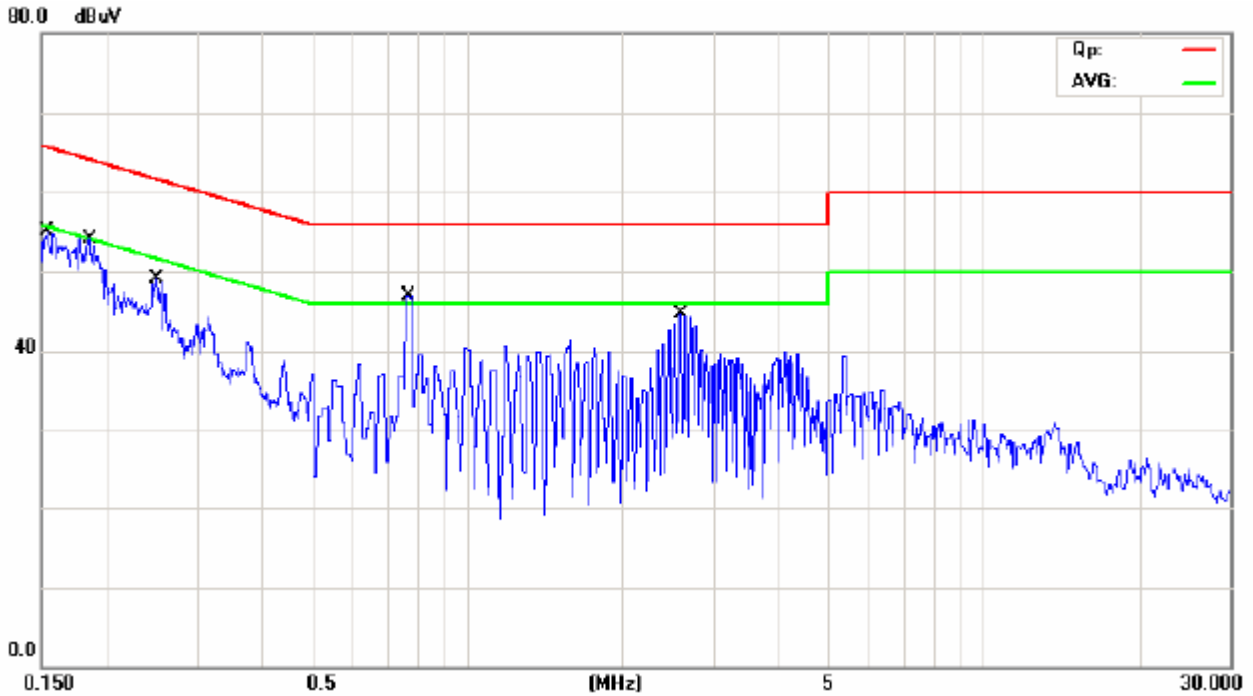

Frequency (MHz)	Reading(dB μ V)				Limit (dB μ V)	
	Live		Neutral		Quasi-peak	Average
	Quasi-peak	Average	Quasi-peak	Average		
0.153	42.50	3.00	--	--	65.79	55.79
0.185	43.94	36.34	--	--	64.24	54.24
0.249	42.10	36.30	--	--	61.79	51.79
0.777	42.46	37.06	--	--	56.00	46.00
2.581	41.03	35.23	--	--	56.00	46.00

The report refers only to the sample tested and does not apply to the bulk.
 This report is issued in confidence to the client and it will be strictly treated as such by the Shenzhen Timeway Technology Consulting Co., Ltd. It may not be reproduced rather in its entirety or in part and it may not be used for advertising. The client to whom the report is issued may, however, show or send it or a certified copy thereof prepared by the Shenzhen Timeway Technology Consulting Co., Ltd to his customer. Supplier or others persons directly concerned. Shenzhen Timeway Technology Consulting Co., Ltd will not, without the consent of the client enter into any discussion of correspondence with any third party concerning the contents of the report.
 In the event of the improper use of the report. The Shenzhen Timeway Technology Consulting Co., Ltd reserves the rights to withdraw it and to adopt any other remedies which may be appropriate.

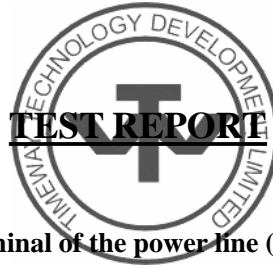

D: Conducted Emission on Neutral Terminal of the power line (150kHz to 30MHz)

EUT set Condition: Play SD
 Adaptor used for test Model No.: ADS-18C-12N 12018GPCU
 Working Voltage: 120V~ 60Hz

Results: Pass

Please refer to following diagram for individual

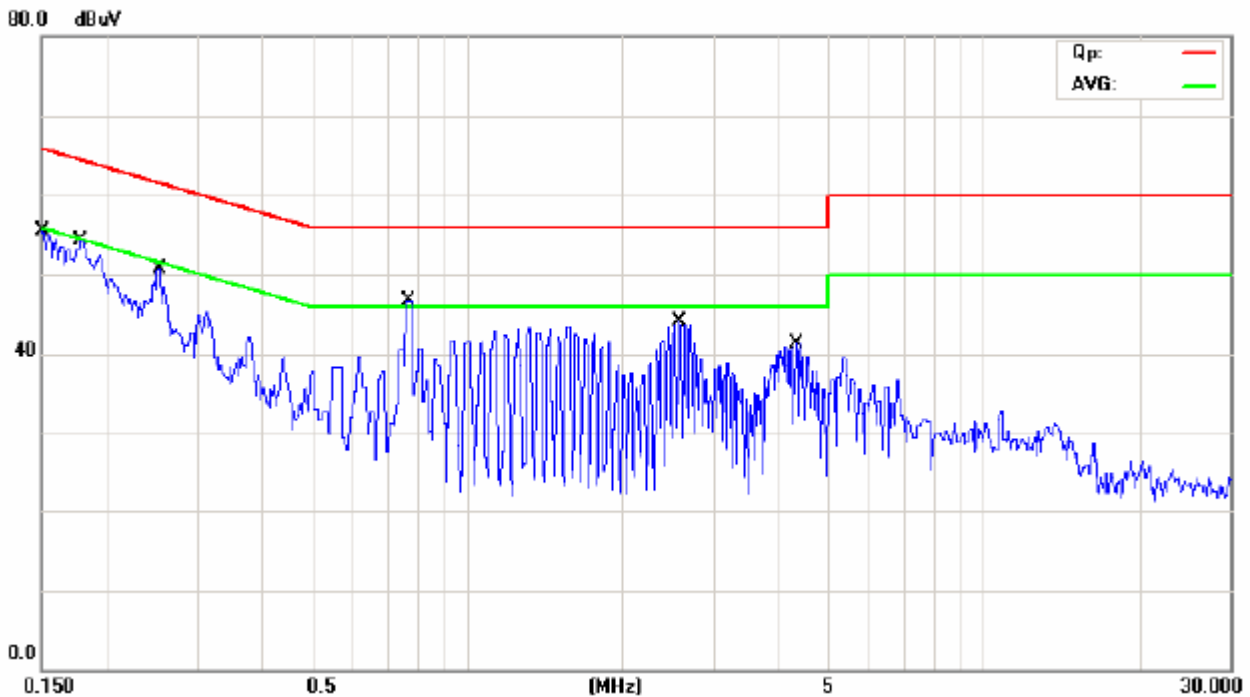

Frequency (MHz)	Reading(dB μ V)				Limit (dB μ V)	
	Live		Neutral		Quasi-peak	Average
	Quasi-peak	Average	Quasi-peak	Average		
0.150	--	--	42.70	4.30	65.96	55.96
0.177	--	--	42.33	36.43	64.63	54.63
0.253	--	--	42.21	36.31	61.65	51.65
0.769	--	--	40.76	35.26	56.00	46.00
2.569	--	--	30.93	19.03	56.00	46.00
4.340	--	--	34.94	26.14	56.00	46.00

The report refers only to the sample tested and does not apply to the bulk.
 This report is issued in confidence to the client and it will be strictly treated as such by the Shenzhen Timeway Technology Consulting Co., Ltd. It may not be reproduced rather in its entirety or in part and it may not be used for adverting. The client to whom the report is issued may, however, show or send it . or a certified copy there of prepared by the Shenzhen Timeway Technology Consulting co., Ltd to his customer. Supplier or others persons directly concerned. Shenzhen Timeway Technology Consulting co., Ltd will not, without the consent of the client enter into any discussion of correspondence with any third party concerning the contents of the report.
 In the event of the improper use of the report. The Shenzhen Timeway Technology Consulting co., Ltd reserves the rights to withdraw it and to adopt any other remedies which may be appropriate.



E: Conducted Emission on Live Terminal of the power line (150kHz to 30MHz)

EUT set Condition: Play USB
 Adaptor used for test Model No.: ADS-18C-12N 12018GPCU
 Working Voltage: 120V~ 60Hz

Results: Pass

Please refer to following diagram for individual

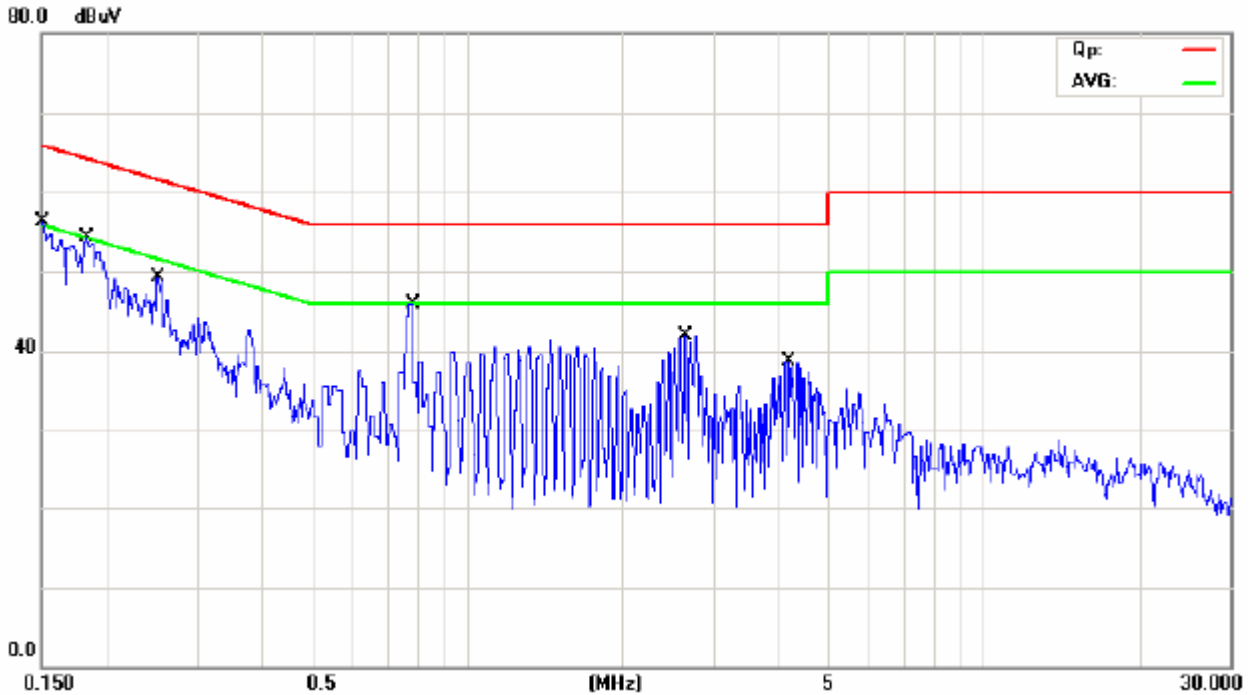

Frequency (MHz)	Reading(dB μ V)				Limit (dB μ V)	
	Live		Neutral		Quasi-peak Average	
	Quasi-peak	Average	Quasi-peak	Average		
0.151	42.70	3.70	--	--	65.93	55.93
0.183	42.23	36.43	--	--	64.35	54.35
0.251	41.91	36.11	--	--	61.71	51.71
0.782	42.77	37.07	--	--	56.00	46.00
2.643	36.46	33.86	--	--	56.00	46.00
4.160	33.26	22.06	--	--	56.00	46.00

The report refers only to the sample tested and does not apply to the bulk.
 This report is issued in confidence to the client and it will be strictly treated as such by the Shenzhen Timeway Technology Consulting Co., Ltd. It may not be reproduced rather in its entirety or in part and it may not be used for advertising. The client to whom the report is issued may, however, show or send it . or a certified copy there of prepared by the Shenzhen Timeway Technology Consulting co., Ltd to his customer. Supplier or others persons directly concerned. Shenzhen Timeway Technology Consulting co., Ltd will not, without the consent of the client enter into any discussion of correspondence with any third party concerning the contents of the report.
 In the event of the improper use of the report. The Shenzhen Timeway Technology Consulting co., Ltd reserves the rights to withdraw it and to adopt any other remedies which may be appropriate.



F: Conducted Emission on Neutral Terminal of the power line (150kHz to 30MHz)

EUT set Condition: Play USB
 Adaptor used for test Model No.: ADS-18C-12N 12018GPCU
 Working Voltage: 120V~ 60Hz

Results: Pass

Please refer to following diagram for individual

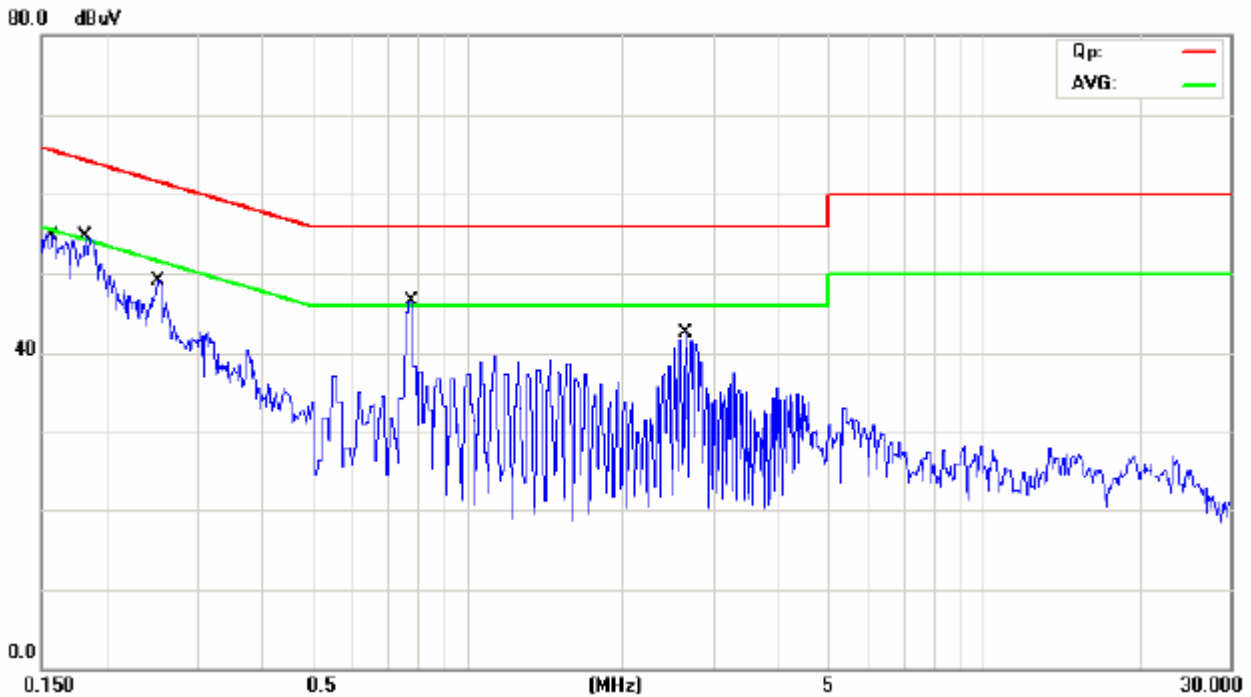

Frequency (MHz)	Reading(dB µ V)				Limit (dB µ V)	
	Live		Neutral		Quasi-peak	Average
	Quasi-peak	Average	Quasi-peak	Average		
0.187	--	--	47.74	36.34	64.14	54.14
0.312	--	--	42.97	37.57	59.91	49.91
0.756	--	--	38.70	33.30	56.00	46.00
2.756	--	--	38.70	33.30	56.00	46.00
9.387	--	--	45.06	37.56	56.00	46.00

The report refers only to the sample tested and does not apply to the bulk.
 This report is issued in confidence to the client and it will be strictly treated as such by the Shenzhen Timeway Technology Consulting Co., Ltd. It may not be reproduced rather in its entirety or in part and it may not be used for advertising. The client to whom the report is issued may, however, show or send it . or a certified copy there of prepared by the Shenzhen Timeway Technology Consulting co., Ltd to his customer. Supplier or others persons directly concerned. Shenzhen Timeway Technology Consulting co., Ltd will not, without the consent of the client enter into any discussion of correspondence with any third party concerning the contents of the report.
 In the event of the improper use of the report. The Shenzhen Timeway Technology Consulting co., Ltd reserves the rights to withdraw it and to adopt any other remedies which may be appropriate.



G: Conducted Emission on Live Terminal of the power line (150kHz to 30MHz)

EUT set Condition: Play CF
 Adaptor used for test Model No.: ADS-18C-12N 12018GPCU
 Working Voltage: 120V~ 60Hz

Results: Pass

Please refer to following diagram for individual

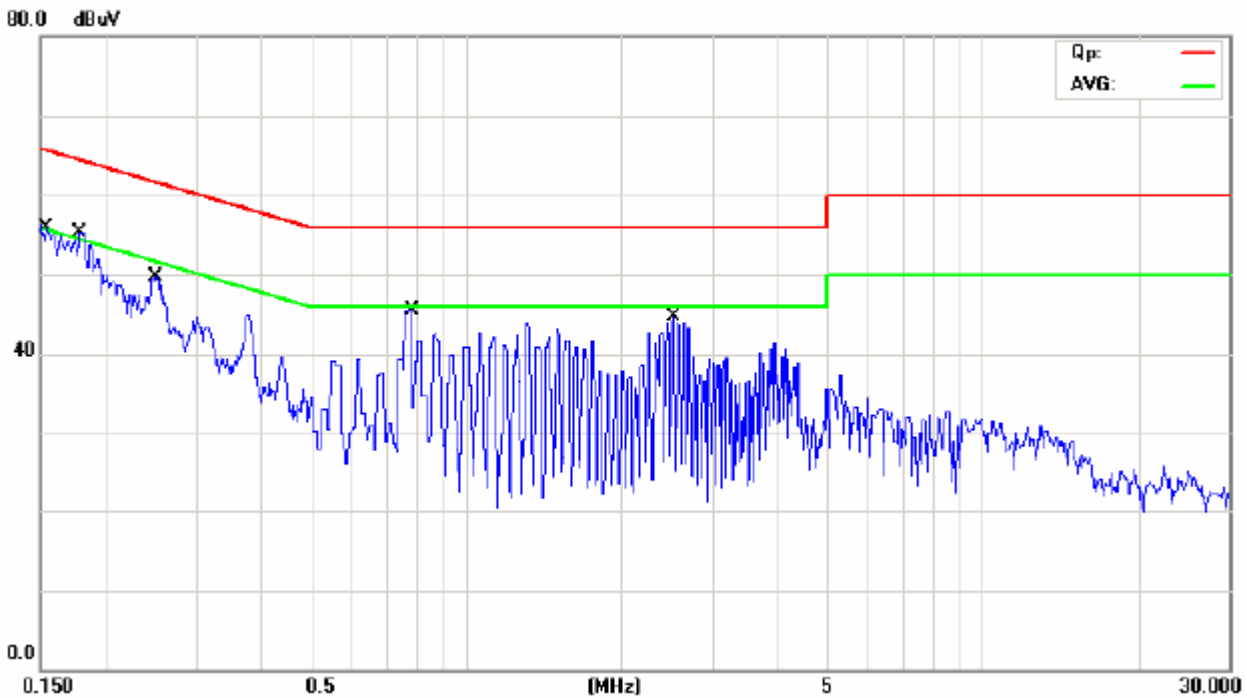

Frequency (MHz)	Reading(dB μ V)				Limit (dB μ V)	
	Live		Neutral		Quasi-peak Average	
	Quasi-peak	Average	Quasi-peak	Average		
0.153	42.90	3.00	--	--	65.82	55.82
0.178	43.13	36.53	--	--	64.56	54.56
0.250	42.01	36.31	--	--	61.74	51.74
0.779	42.97	37.07	--	--	56.00	46.00
2.516	40.61	34.01	--	--	56.00	46.00

The report refers only to the sample tested and does not apply to the bulk.
 This report is issued in confidence to the client and it will be strictly treated as such by the Shenzhen Timeway Technology Consulting Co., Ltd. It may not be reproduced rather in its entirety or in part and it may not be used for advertising. The client to whom the report is issued may, however, show or send it . or a certified copy there of prepared by the Shenzhen Timeway Technology Consulting co., Ltd to his customer. Supplier or others persons directly concerned. Shenzhen Timeway Technology Consulting co., Ltd will not, without the consent of the client enter into any discussion of correspondence with any third party concerning the contents of the report.
 In the event of the improper use of the report. The Shenzhen Timeway Technology Consulting co., Ltd reserves the rights to withdraw it and to adopt any other remedies which may be appropriate.



H: Conducted Emission on Neutral Terminal of the power line (150kHz to 30MHz)

EUT set Condition: Play CF
 Adaptor used for test Model No.: ADS-18C-12N 12018GPCU
 Working Voltage: 120V~ 60Hz

Results: Pass

Please refer to following diagram for individual

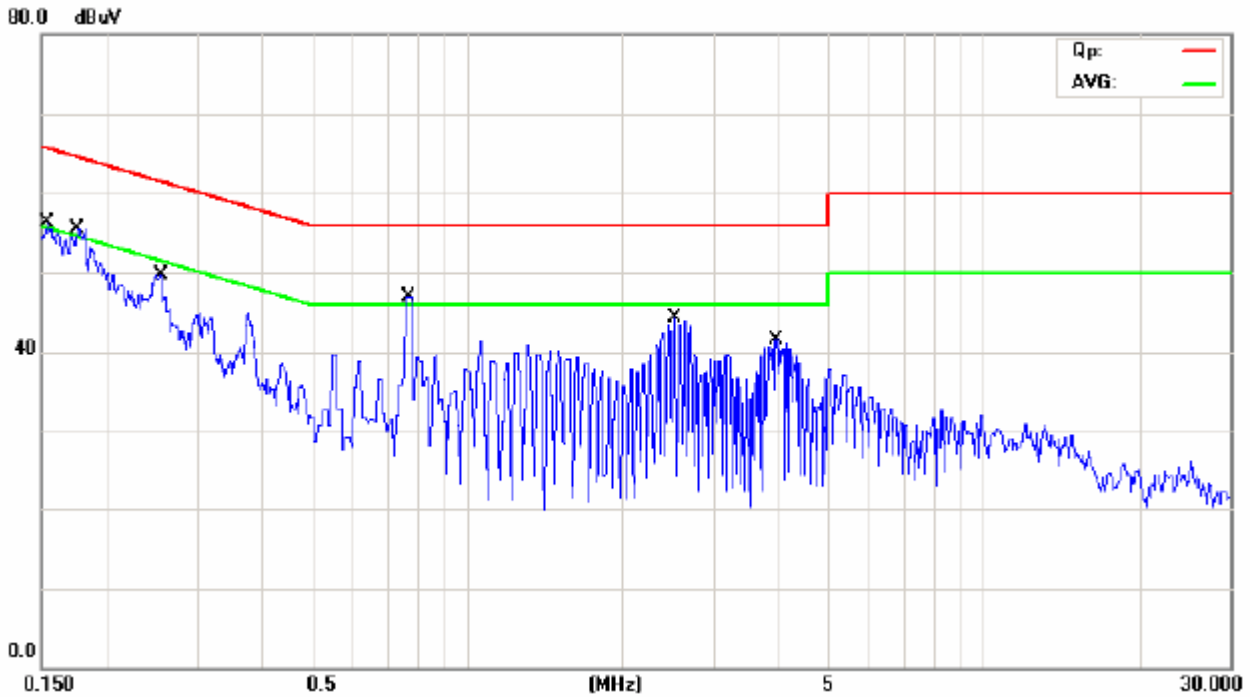

Frequency (MHz)	Reading(dB µ V)				Limit (dB µ V)	
	Live		Neutral		Quasi-peak	Average
	Quasi-peak	Average	Quasi-peak	Average		
0.151	--	--	43.10	3.20	65.91	55.91
0.175	--	--	42.13	36.43	64.68	54.68
0.254	--	--	41.21	36.31	61.63	51.63
0.778	--	--	43.27	37.07	56.00	46.00
2.513	--	--	41.51	36.11	56.00	46.00
3.942	--	--	16.18	9.58	56.00	46.00

The report refers only to the sample tested and does not apply to the bulk.
 This report is issued in confidence to the client and it will be strictly treated as such by the Shenzhen Timeway Technology Consulting Co., Ltd. It may not be reproduced rather in its entirety or in part and it may not be used for advertizing. The client to whom the report is issued may, however, show or send it . or a certified copy there of prepared by the Shenzhen Timeway Technology Consulting co., Ltd to his customer. Supplier or others persons directly concerned. Shenzhen Timeway Technology Consulting co., Ltd will not, without the consent of the client enter into any discussion of correspondence with any third party concerning the contents of the report.
 In the event of the improper use of the report. The Shenzhen Timeway Technology Consulting co., Ltd reserves the rights to withdraw it and to adopt any other remedies which may be appropriate.



I: Conducted Emission on Live Terminal of the power line (150kHz to 30MHz)

EUT set Condition: Connected to PC
 Adaptor used for test Model No.: ADS-18C-12N 12018GPCU
 Working Voltage: 120V~ 60Hz

Results: Pass

Please refer to following diagram for individual

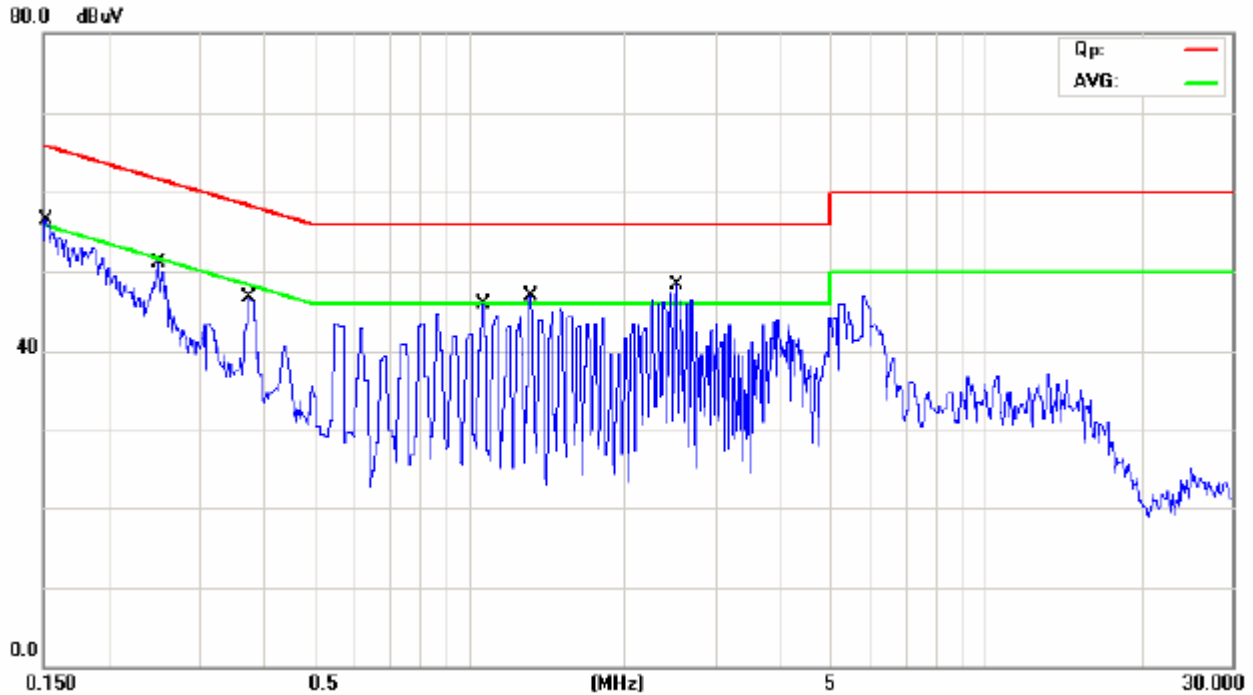

Frequency (MHz)	Reading(dB μ V)				Limit (dB μ V)	
	Live		Neutral		Quasi-peak Average	
	Quasi-peak	Average	Quasi-peak	Average		
0.150	42.90	7.00	--	--	65.97	55.97
0.249	43.21	36.41	--	--	61.77	51.77
0.374	41.14	36.34	--	--	58.39	48.39
1.055	13.82	5.82	--	--	56.00	46.00
1.302	13.82	5.32	--	--	56.00	46.00
2.511	43.70	37.70	--	--	56.00	46.00

The report refers only to the sample tested and does not apply to the bulk.
 This report is issued in confidence to the client and it will be strictly treated as such by the Shenzhen Timeway Technology Consulting Co., Ltd. It may not be reproduced in its entirety or in part and it may not be used for advertising. The client to whom the report is issued may, however, show or send it, or a certified copy thereof prepared by the Shenzhen Timeway Technology Consulting Co., Ltd to his customer. Supplier or other persons directly concerned. Shenzhen Timeway Technology Consulting Co., Ltd will not, without the consent of the client enter into any discussion of correspondence with any third party concerning the contents of the report.
 In the event of the improper use of the report. The Shenzhen Timeway Technology Consulting Co., Ltd reserves the rights to withdraw it and to adopt any other remedies which may be appropriate.



J: Conducted Emission on Neutral Terminal of the power line (150kHz to 30MHz)

EUT set Condition: Connected to PC
 Adaptor used for test Model No.: ADS-18C-12N 12018GPCU
 Working Voltage: 120V~ 60Hz

Results: Pass

Please refer to following diagram for individual

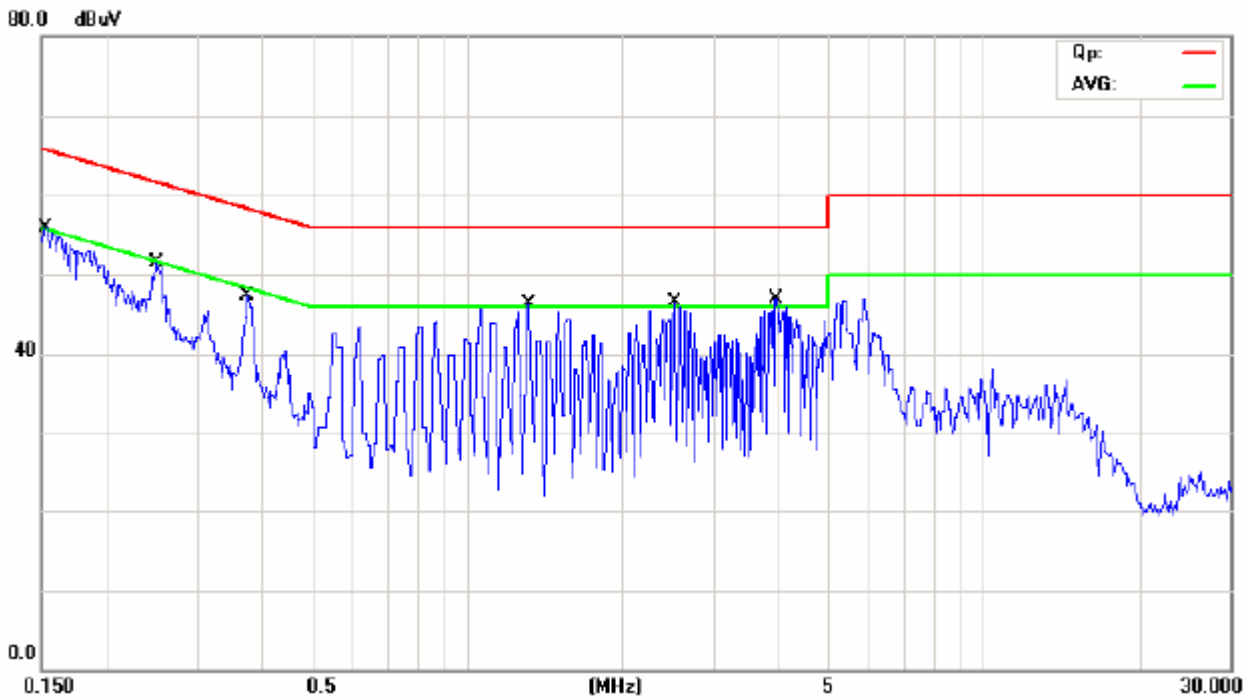

Frequency (MHz)	Reading(dB μ V)				Limit (dB μ V)	
	Live		Neutral		Quasi-peak	Average
	Quasi-peak	Average	Quasi-peak	Average		
0.152	--	--	43.10	3.40	65.89	55.89
0.249	--	--	43.00	36.40	61.79	51.79
0.374	--	--	41.24	36.34	58.40	48.40
1.307	--	--	18.22	7.92	56.00	46.00
2.511	--	--	43.70	37.70	56.00	46.00
3.946	--	--	26.18	16.18	56.00	46.00

The report refers only to the sample tested and does not apply to the bulk.
 This report is issued in confidence to the client and it will be strictly treated as such by the Shenzhen Timeway Technology Consulting Co., Ltd. It may not be reproduced rather in its entirety or in part and it may not be used for adverting. The client to whom the report is issued may, however, show or send it . or a certified copy there of prepared by the Shenzhen Timeway Technology Consulting co., Ltd to his customer. Supplier or others persons directly concerned. Shenzhen Timeway Technology Consulting co., Ltd will not, without the consent of the client enter into any discussion of correspondence with any third party concerning the contents of the report.
 In the event of the improper use of the report. The Shenzhen Timeway Technology Consulting co., Ltd reserves the rights to withdraw it and to adopt any other remedies which may be appropriate.



K: Conducted Emission on Line Terminal of the power line (150kHz to 30MHz)

EUT set Condition: Memory
 Adaptor used for test Model No.: XKD-C1500IC12.0-18C-US
 Working Voltage: 120V~ 60Hz

Results: Pass

Please refer to following diagram for individual

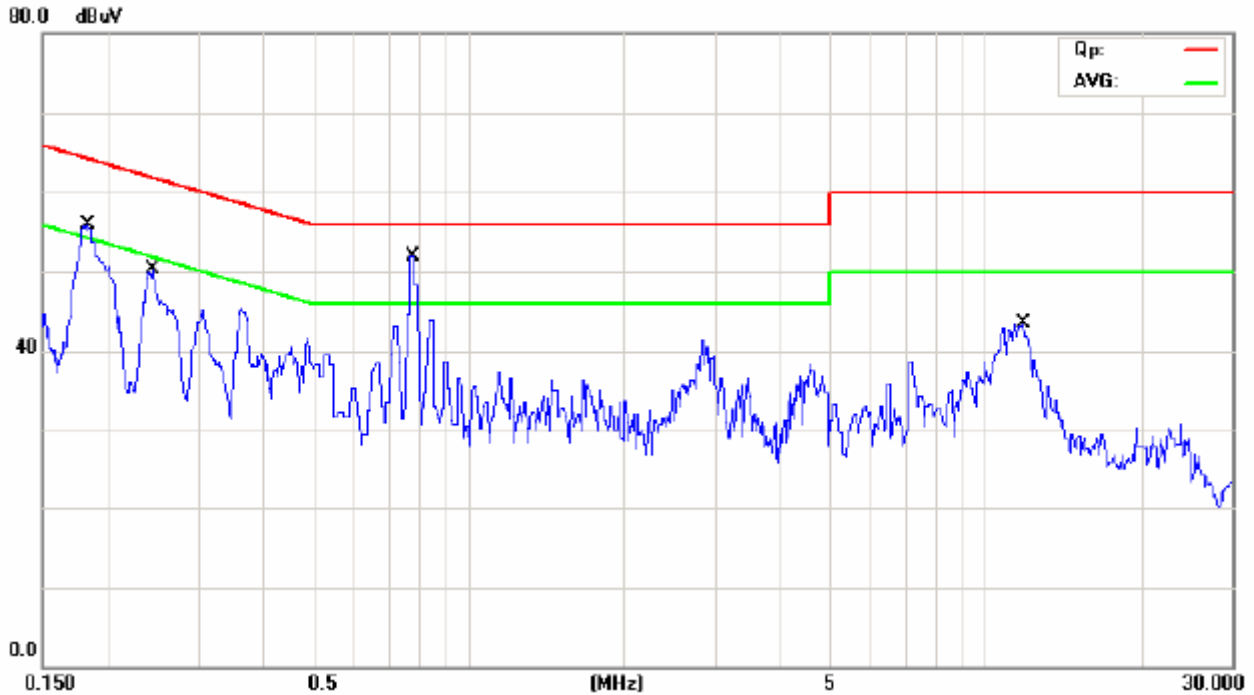

Frequency (MHz)	Reading(dB μ V)				Limit (dB μ V)	
	Live		Neutral		Quasi-peak Average	
	Quasi-peak	Average	Quasi-peak	Average		
0.183	50.43	36.53	--	--	64.35	54.35
0.244	42.30	31.40	--	--	61.96	51.96
0.776	44.06	39.46	--	--	56.00	46.00
11.826	33.66	23.86	--	--	60.00	50.00

The report refers only to the sample tested and does not apply to the bulk.
 This report is issued in confidence to the client and it will be strictly treated as such by the Shenzhen Timeway Technology Consulting Co., Ltd. It may not be reproduced rather in its entirety or in part and it may not be used for advertising. The client to whom the report is issued may, however, show or send it or a certified copy thereof prepared by the Shenzhen Timeway Technology Consulting Co., Ltd to his customer. Supplier or others persons directly concerned. Shenzhen Timeway Technology Consulting Co., Ltd will not, without the consent of the client enter into any discussion of correspondence with any third party concerning the contents of the report.
 In the event of the improper use of the report. The Shenzhen Timeway Technology Consulting Co., Ltd reserves the rights to withdraw it and to adopt any other remedies which may be appropriate.



L: Conducted Emission on Neutral Terminal of the power line (150kHz to 30MHz)

EUT set Condition: Memory
 Adaptor used for test Model No.: XKD-C1500IC12.0-18C-US
 Working Voltage: 120V~ 60Hz

Results: Pass

Please refer to following diagram for individual

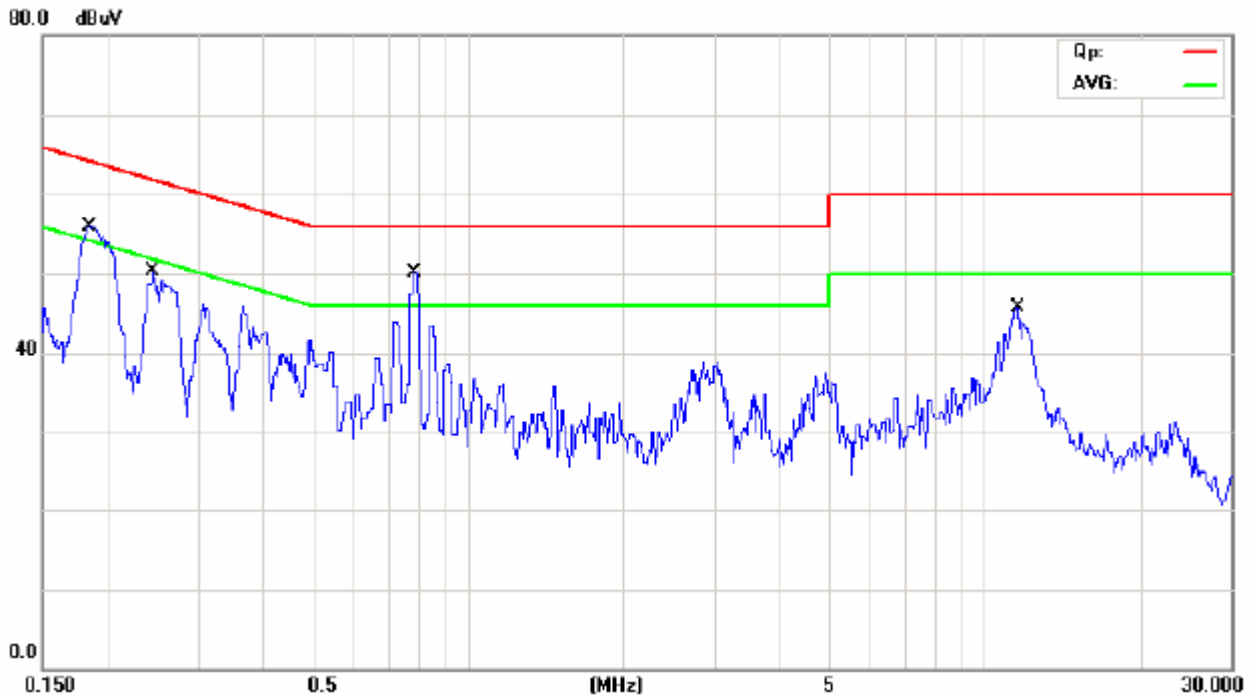

Frequency (MHz)	Reading(dB μ V)				Limit (dB μ V)	
	Live		Neutral		Quasi-peak	Average
	Quasi-peak	Average	Quasi-peak	Average		
0.184	--	--	50.54	36.54	64.30	54.30
0.245	--	--	42.10	31.20	61.90	51.90
0.786	--	--	42.67	37.47	56.00	46.00
11.505	--	--	33.77	24.47	60.00	50.00

The report refers only to the sample tested and does not apply to the bulk.
 This report is issued in confidence to the client and it will be strictly treated as such by the Shenzhen Timeway Technology Consulting Co., Ltd. It may not be reproduced rather in its entirety or in part and it may not be used for adverting. The client to whom the report is issued may, however, show or send it . or a certified copy there of prepared by the Shenzhen Timeway Technology Consulting co., Ltd to his customer. Supplier or others persons directly concerned. Shenzhen Timeway Technology Consulting co., Ltd will not, without the consent of the client enter into any discussion of correspondence with any third party concerning the contents of the report.
 In the event of the improper use of the report. The Shenzhen Timeway Technology Consulting co., Ltd reserves the rights to withdraw it and to adopt any other remedies which may be appropriate.

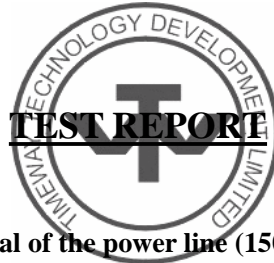

M: Conducted Emission on Line Terminal of the power line (150kHz to 30MHz)

EUT set Condition: Play SD
Adaptor used for test Model No.: XKD-C1500IC12.0-18C-US
Working Voltage: 120V~ 60Hz

Results: Pass

Please refer to following diagram for individual

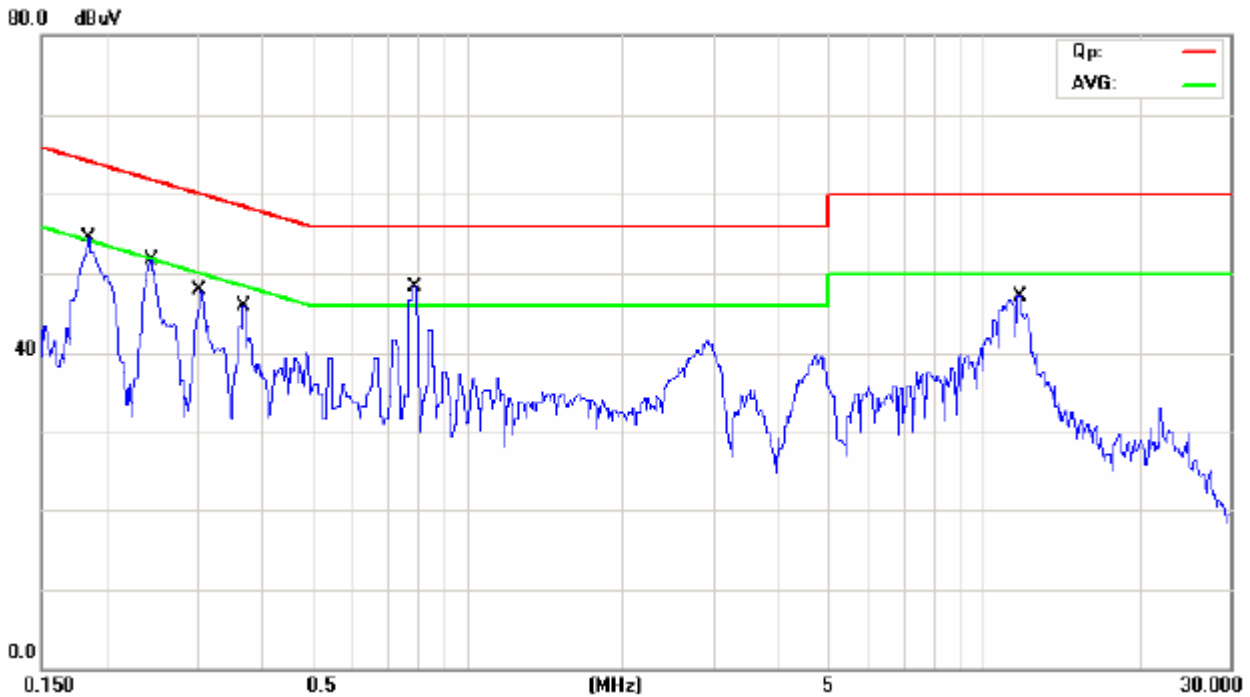

Frequency (MHz)	Reading(dB μ V)				Limit (dB μ V)	
	Live		Neutral		Quasi-peak Average	
	Quasi-peak	Average	Quasi-peak	Average		
0.184	44.84	36.54	--	--	64.29	54.29
0.243	43.20	31.10	--	--	61.99	51.99
0.303	40.66	33.66	--	--	60.15	50.15
0.368	32.43	23.83	--	--	58.54	48.54
0.789	43.38	37.08	--	--	56.00	46.00
11.710	38.97	22.27	--	--	60.00	50.00

The report refers only to the sample tested and does not apply to the bulk.
This report is issued in confidence to the client and it will be strictly treated as such by the Shenzhen Timeway Technology Consulting Co., Ltd. It may not be reproduced in its entirety or in part and it may not be used for advertising. The client to whom the report is issued may, however, show or send it, or a certified copy thereof prepared by the Shenzhen Timeway Technology Consulting Co., Ltd to his customer. Supplier or other persons directly concerned. Shenzhen Timeway Technology Consulting Co., Ltd will not, without the consent of the client enter into any discussion of correspondence with any third party concerning the contents of the report.
In the event of the improper use of the report. The Shenzhen Timeway Technology Consulting Co., Ltd reserves the rights to withdraw it and to adopt any other remedies which may be appropriate.

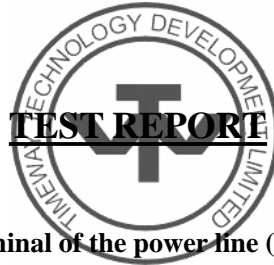

N: Conducted Emission on Neutral Terminal of the power line (150kHz to 30MHz)

EUT set Condition: Play SD
 Adaptor used for test Model No.: XKD-C1500IC12.0-18C-US
 Working Voltage: 120V~ 60Hz

Results: Pass

Please refer to following diagram for individual

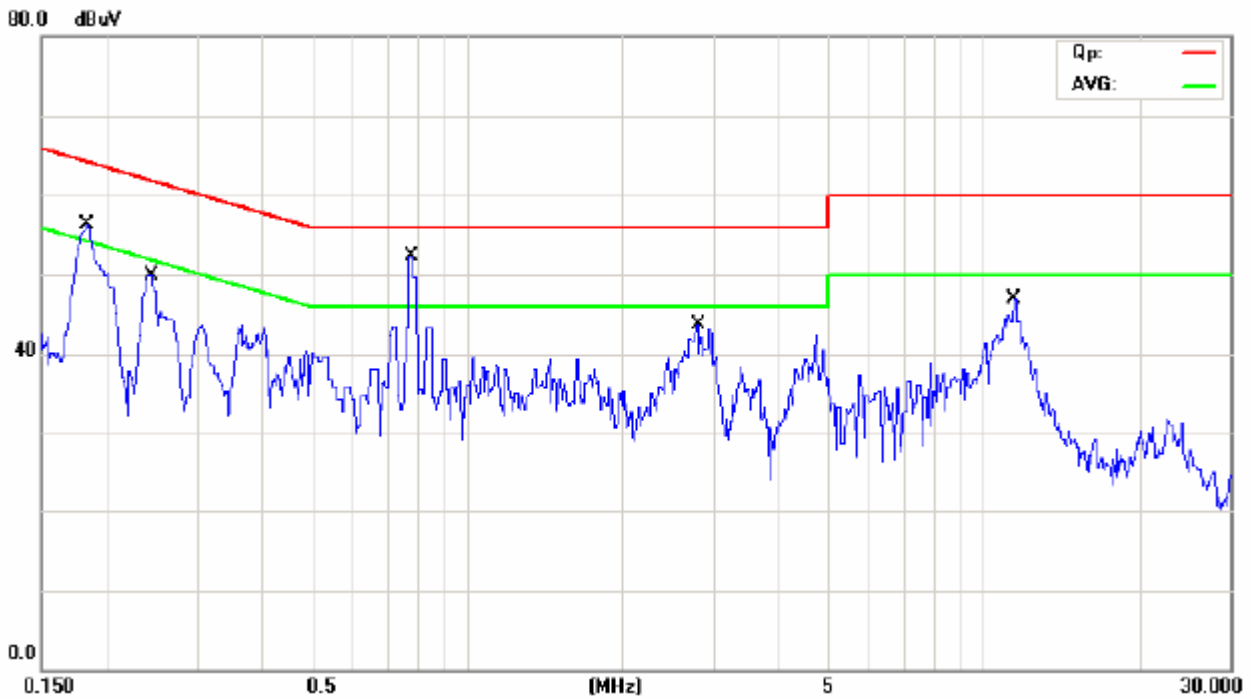

Frequency (MHz)	Reading(dB μ V)				Limit (dB μ V)	
	Live		Neutral		Quasi-peak	Average
	Quasi-peak	Average	Quasi-peak	Average		
0.182	--	--	50.73	36.53	64.37	54.37
0.243	--	--	42.70	31.70	61.98	51.98
0.787	--	--	44.67	37.07	56.00	46.00
2.778	--	--	33.31	16.11	56.00	46.00
11.437	--	--	34.97	25.67	60.00	50.00

The report refers only to the sample tested and does not apply to the bulk.
 This report is issued in confidence to the client and it will be strictly treated as such by the Shenzhen Timeway Technology Consulting Co., Ltd. It may not be reproduced rather in its entirety or in part and it may not be used for adverting. The client to whom the report is issued may, however, show or send it . or a certified copy there of prepared by the Shenzhen Timeway Technology Consulting co., Ltd to his customer. Supplier or others persons directly concerned. Shenzhen Timeway Technology Consulting co., Ltd will not, without the consent of the client enter into any discussion of correspondence with any third party concerning the contents of the report.
 In the event of the improper use of the report. The Shenzhen Timeway Technology Consulting co., Ltd reserves the rights to withdraw it and to adopt any other remedies which may be appropriate.



O: Conducted Emission on Line Terminal of the power line (150kHz to 30MHz)

EUT set Condition: Play USB
 Adaptor used for test Model No.: XKD-C1500IC12.0-18C-US
 Working Voltage: 120V~ 60Hz

Results: Pass

Please refer to following diagram for individual

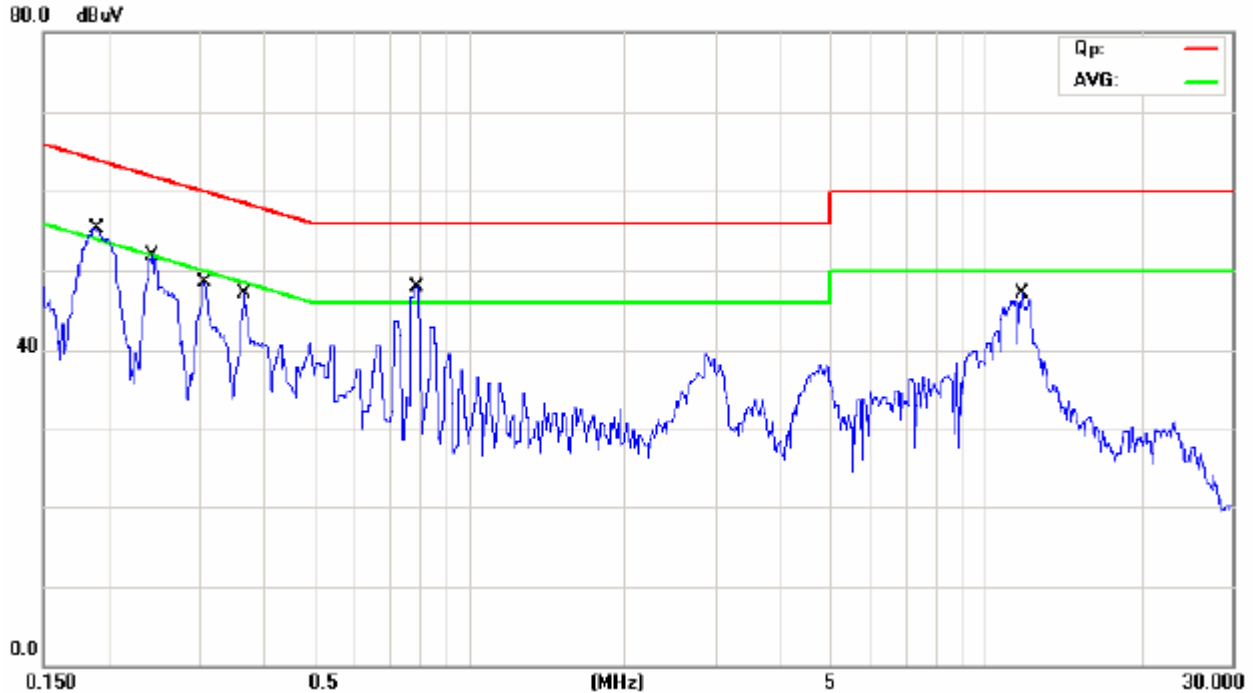

Frequency (MHz)	Reading(dB μ V)				Limit (dB μ V)	
	Live		Neutral		Quasi-peak Average	
	Quasi-peak	Average	Quasi-peak	Average		
0.187	45.14	36.34	--	--	64.14	54.14
0.242	43.50	31.70	--	--	62.01	52.01
0.305	40.66	33.86	--	--	60.10	50.10
0.367	33.53	24.93	--	--	58.56	48.56
0.789	43.58	36.98	--	--	56.00	46.00
11.749	35.97	22.97	--	--	60.00	50.00

The report refers only to the sample tested and does not apply to the bulk.
 This report is issued in confidence to the client and it will be strictly treated as such by the Shenzhen Timeway Technology Consulting Co., Ltd. It may not be reproduced rather in its entirety or in part and it may not be used for advertising. The client to whom the report is issued may, however, show or send it or a certified copy thereof prepared by the Shenzhen Timeway Technology Consulting Co., Ltd to his customer. Supplier or others persons directly concerned. Shenzhen Timeway Technology Consulting Co., Ltd will not, without the consent of the client enter into any discussion of correspondence with any third party concerning the contents of the report.
 In the event of the improper use of the report. The Shenzhen Timeway Technology Consulting Co., Ltd reserves the rights to withdraw it and to adopt any other remedies which may be appropriate.



P: Conducted Emission on Neutral Terminal of the power line (150kHz to 30MHz)

EUT set Condition: Play USB
 Adaptor used for test Model No.: XKD-C1500IC12.0-18C-US
 Working Voltage: 120V~ 60Hz

Results: Pass

Please refer to following diagram for individual

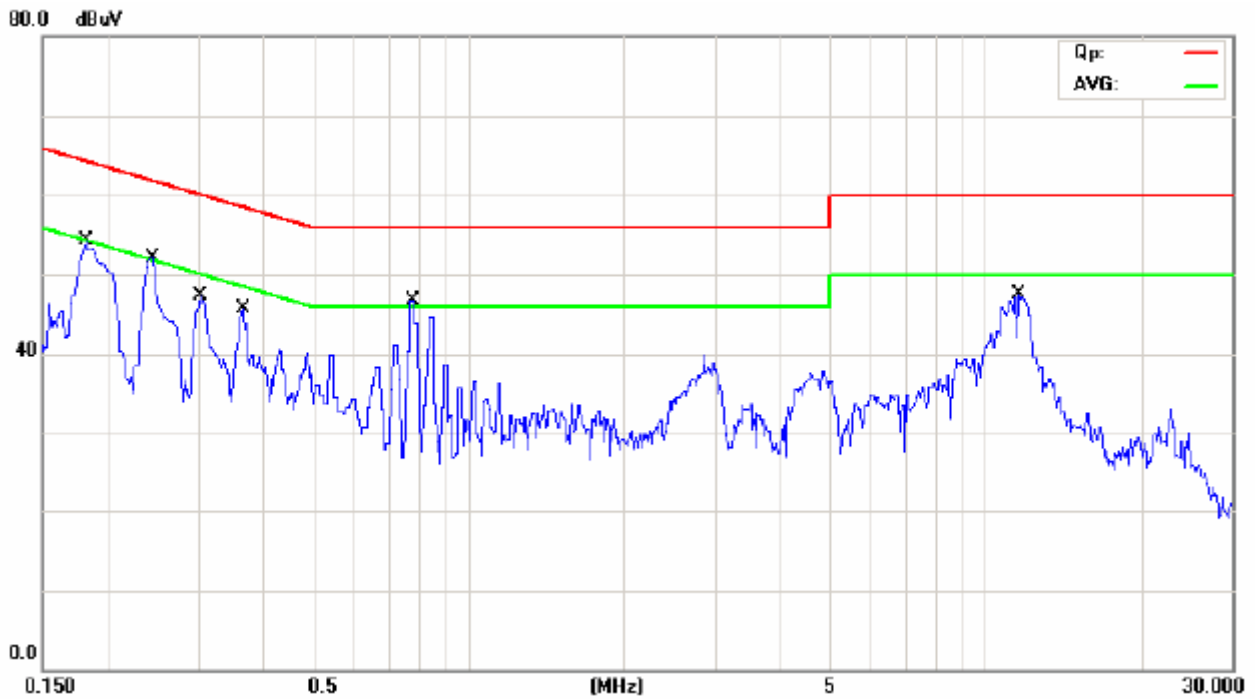

Frequency (MHz)	Reading(dB µ V)				Limit (dB µ V)	
	Live		Neutral		Quasi-peak	Average
	Quasi-peak	Average	Quasi-peak	Average		
0.181	--	--	48.73	36.53	64.42	54.42
0.243	--	--	43.40	31.50	61.98	51.98
0.301	--	--	40.96	34.36	60.22	50.22
0.365	--	--	33.53	25.23	58.60	48.60
0.778	--	--	40.36	33.36	56.00	46.00
11.554	--	--	39.87	23.27	60.00	50.00

The report refers only to the sample tested and does not apply to the bulk.
 This report is issued in confidence to the client and it will be strictly treated as such by the Shenzhen Timeway Technology Consulting Co., Ltd. It may not be reproduced rather in its entirety or in part and it may not be used for advertizing. The client to whom the report is issued may, however, show or send it . or a certified copy there of prepared by the Shenzhen Timeway Technology Consulting co., Ltd to his customer. Supplier or others persons directly concerned. Shenzhen Timeway Technology Consulting co., Ltd will not, without the consent of the client enter into any discussion of correspondence with any third party concerning the contents of the report.
 In the event of the improper use of the report. The Shenzhen Timeway Technology Consulting co., Ltd reserves the rights to withdraw it and to adopt any other remedies which may be appropriate.

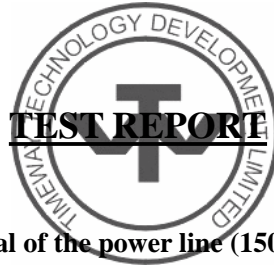

Q: Conducted Emission on Line Terminal of the power line (150kHz to 30MHz)

EUT set Condition: Play CF
 Adaptor used for test Model No.: XKD-C1500IC12.0-18C-US
 Working Voltage: 120V~ 60Hz

Results: Pass

Please refer to following diagram for individual

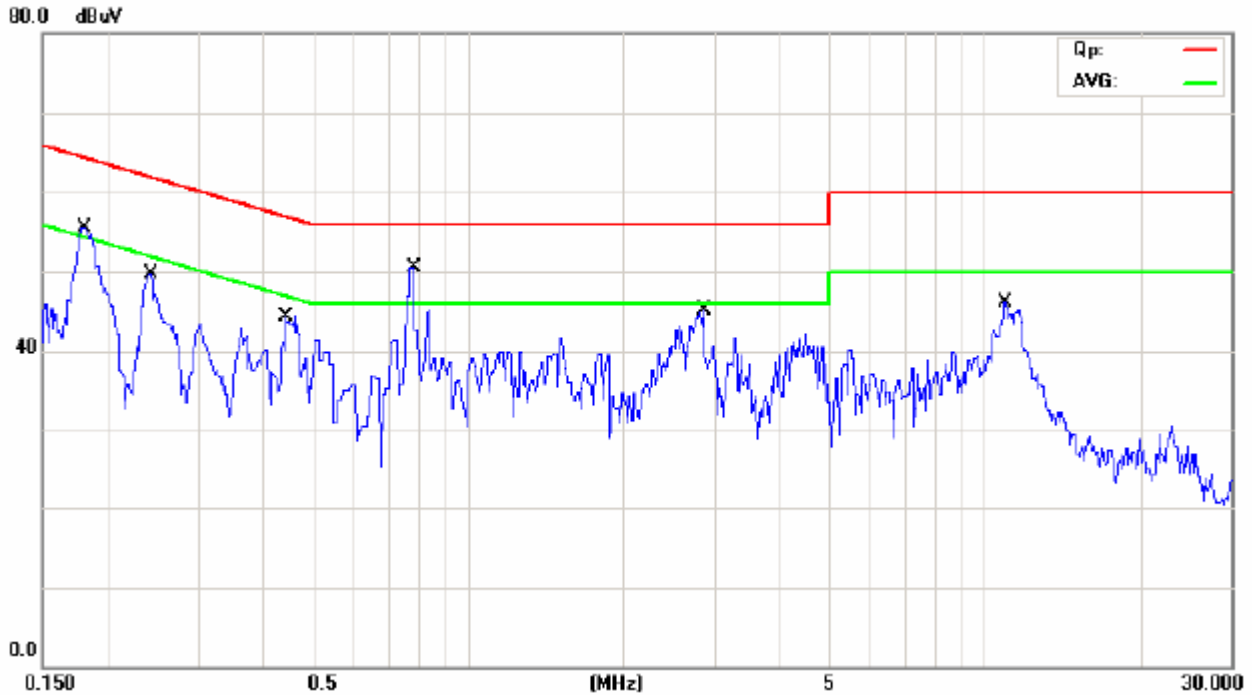

Frequency (MHz)	Reading(dB μ V)				Limit (dB μ V)	
	Live		Neutral		Quasi-peak Average	
	Quasi-peak	Average	Quasi-peak	Average		
0.180	50.73	36.63	--	--	64.46	54.46
0.241	41.90	31.20	--	--	62.03	52.03
0.441	34.11	18.21	--	--	57.03	47.03
0.783	44.37	37.07	--	--	56.00	46.00
2.839	33.34	17.64	--	--	56.00	46.00
10.934	34.18	24.98	--	--	60.00	50.00

The report refers only to the sample tested and does not apply to the bulk.
 This report is issued in confidence to the client and it will be strictly treated as such by the Shenzhen Timeway Technology Consulting Co., Ltd. It may not be reproduced rather in its entirety or in part and it may not be used for advertising. The client to whom the report is issued may, however, show or send it or a certified copy thereof prepared by the Shenzhen Timeway Technology Consulting Co., Ltd to his customer. Supplier or others persons directly concerned. Shenzhen Timeway Technology Consulting Co., Ltd will not, without the consent of the client enter into any discussion of correspondence with any third party concerning the contents of the report.
 In the event of the improper use of the report. The Shenzhen Timeway Technology Consulting Co., Ltd reserves the rights to withdraw it and to adopt any other remedies which may be appropriate.

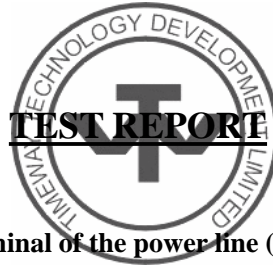

R: Conducted Emission on Neutral Terminal of the power line (150kHz to 30MHz)

EUT set Condition: Play CF
Adaptor used for test Model No.: XKD-C1500IC12.0-18C-US
Working Voltage: 120V~ 60Hz

Results: Pass

Please refer to following diagram for individual

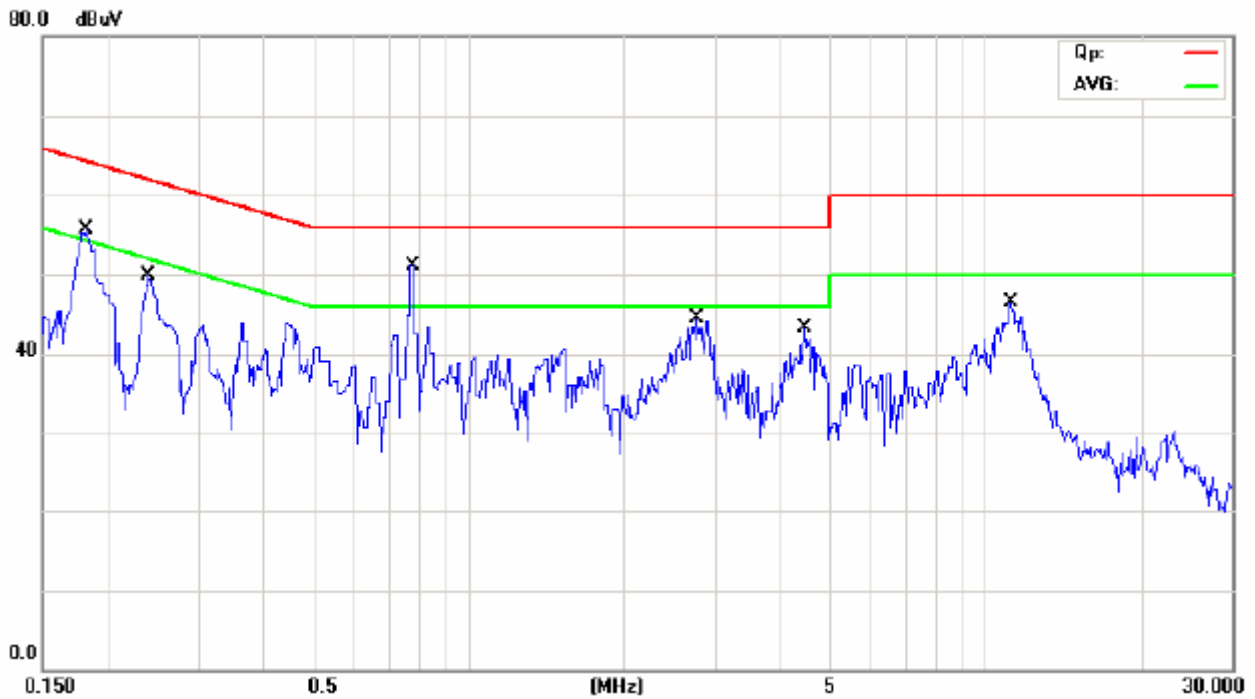

Frequency (MHz)	Reading(dB µ V)				Limit (dB µ V)	
	Live		Neutral		Quasi-peak	Average
	Quasi-peak	Average	Quasi-peak	Average		
0.182	--	--	50.53	36.53	64.38	54.38
0.240	--	--	42.30	31.90	62.10	52.10
0.783	--	--	44.37	37.07	56.00	46.00
2.746	--	--	33.30	18.70	56.00	46.00
4.455	--	--	31.38	17.28	56.00	46.00
11.179	--	--	35.28	28.98	60.00	50.00

The report refers only to the sample tested and does not apply to the bulk.
This report is issued in confidence to the client and it will be strictly treated as such by the Shenzhen Timeway Technology Consulting Co., Ltd. It may not be reproduced rather in its entirety or in part and it may not be used for adverting. The client to whom the report is issued may, however, show or send it . or a certified copy there of prepared by the Shenzhen Timeway Technology Consulting co., Ltd to his customer. Supplier or others persons directly concerned. Shenzhen Timeway Technology Consulting co., Ltd will not, without the consent of the client enter into any discussion of correspondence with any third party concerning the contents of the report.
In the event of the improper use of the report. The Shenzhen Timeway Technology Consulting co., Ltd reserves the rights to withdraw it and to adopt any other remedies which may be appropriate.



S: Conducted Emission on Line Terminal of the power line (150kHz to 30MHz)

EUT set Condition: Connect to PC
 Adaptor used for test Model No.: XKD-C1500IC12.0-18C-US
 Working Voltage: 120V~ 60Hz

Results: Pass

Please refer to following diagram for individual

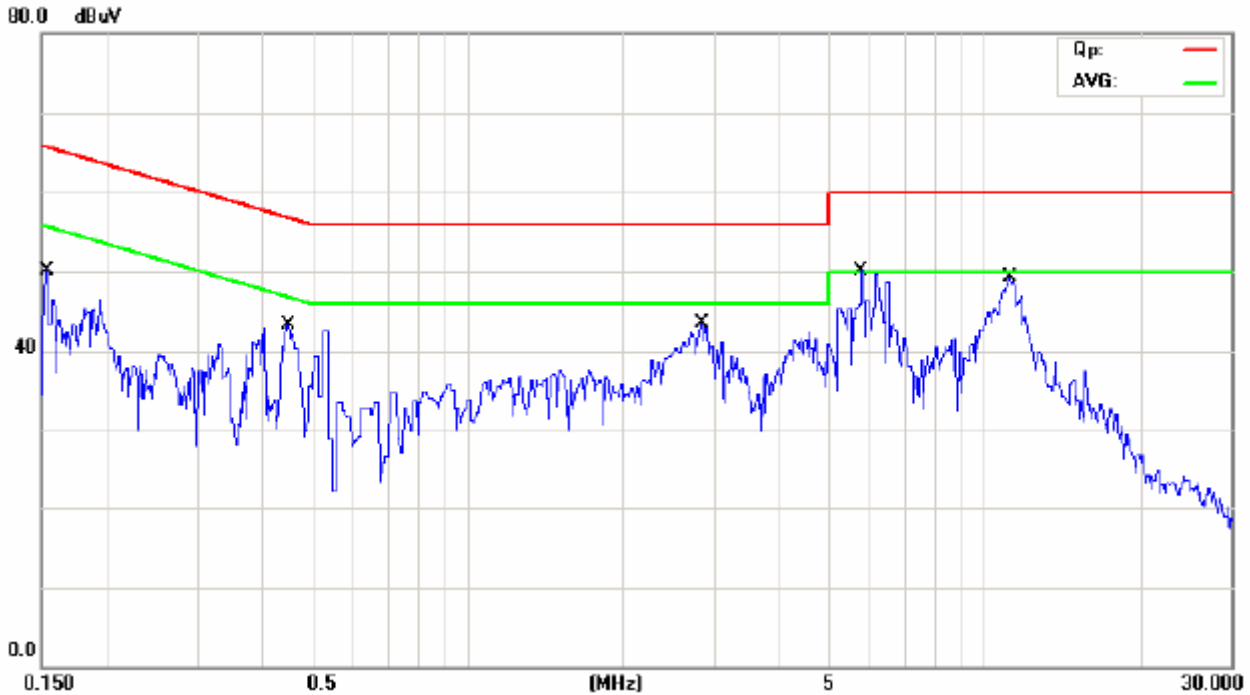

Frequency (MHz)	Reading(dB μ V)				Limit (dB μ V)	
	Live		Neutral		Quasi-peak	Average
	Quasi-peak	Average	Quasi-peak	Average		
0.153	32.00	5.20	--	--	65.84	55.84
0.447	32.41	20.81	--	--	56.92	46.92
2.826	34.33	25.43	--	--	56.00	46.00
5.788	43.67	38.57	--	--	60.00	50.00
11.165	41.28	25.48	--	--	60.00	50.00

The report refers only to the sample tested and does not apply to the bulk.
 This report is issued in confidence to the client and it will be strictly treated as such by the Shenzhen Timeway Technology Consulting Co., Ltd. It may not be reproduced rather in its entirety or in part and it may not be used for advertising. The client to whom the report is issued may, however, show or send it . or a certified copy there of prepared by the Shenzhen Timeway Technology Consulting co., Ltd to his customer. Supplier or others persons directly concerned. Shenzhen Timeway Technology Consulting co., Ltd will not, without the consent of the client enter into any discussion of correspondence with any third party concerning the contents of the report.
 In the event of the improper use of the report. The Shenzhen Timeway Technology Consulting co., Ltd reserves the rights to withdraw it and to adopt any other remedies which may be appropriate.



T: Conducted Emission on Neutral Terminal of the power line (150kHz to 30MHz)

EUT set Condition: Connect to PC
Adaptor used for test Model No.: XKD-C2000IC5.0-12W
Working Voltage: 120V~ 60Hz

Results: Pass

Please refer to following diagram for individual

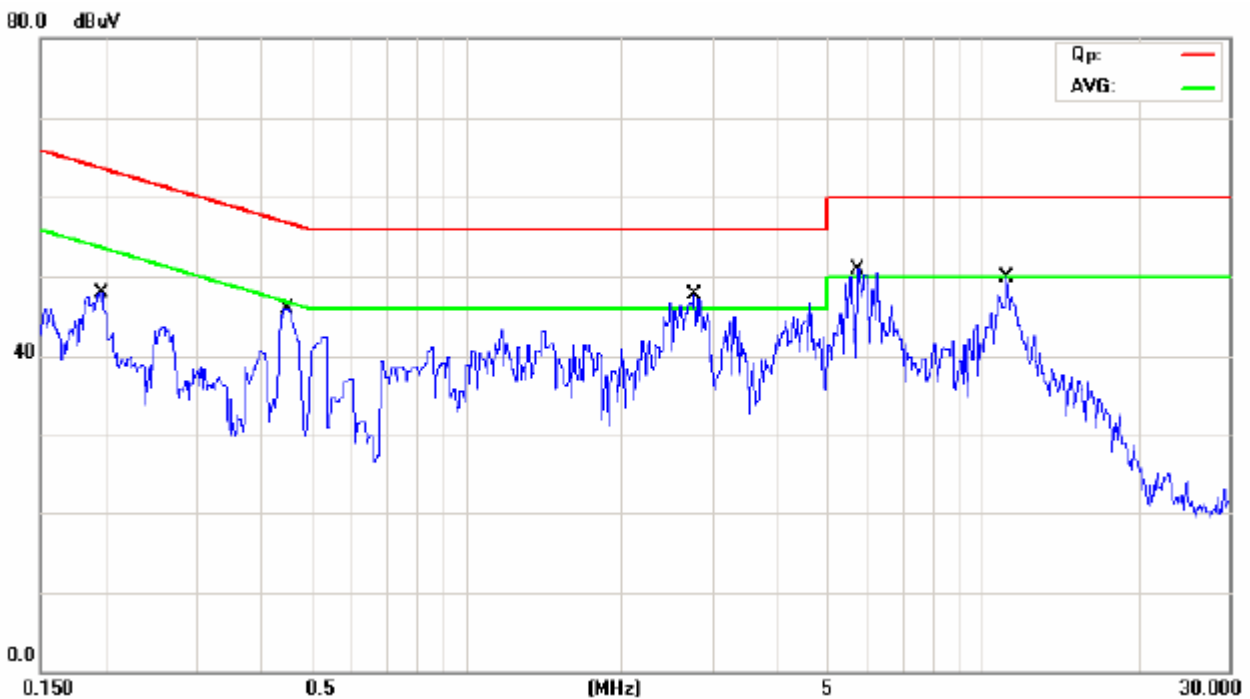

Frequency (MHz)	Reading(dB µ V)				Limit (dB µ V)	
	Live		Neutral		Quasi-peak	Average
	Quasi-peak	Average	Quasi-peak	Average		
0.198	--	--	41.15	24.75	63.69	53.69
0.449	--	--	39.12	22.52	56.89	46.89
2.757	--	--	35.80	26.40	56.00	46.00
5.755	--	--	32.68	21.18	60.00	50.00
11.085	--	--	39.58	26.68	60.00	50.00

The report refers only to the sample tested and does not apply to the bulk.
This report is issued in confidence to the client and it will be strictly treated as such by the Shenzhen Timeway Technology Consulting Co., Ltd. It may not be reproduced rather in its entirety or in part and it may not be used for adverting. The client to whom the report is issued may, however, show or send it . or a certified copy there of prepared by the Shenzhen Timeway Technology Consulting co., Ltd to his customer. Supplier or others persons directly concerned. Shenzhen Timeway Technology Consulting co., Ltd will not, without the consent of the client enter into any discussion of correspondence with any third party concerning the contents of the report.
In the event of the improper use of the report. The Shenzhen Timeway Technology Consulting co., Ltd reserves the rights to withdraw it and to adopt any other remedies which may be appropriate.



5.0 Radiated Disturbance Test

5.1 Schematics of the test

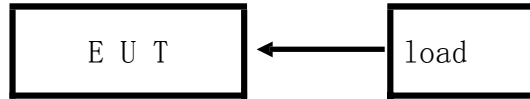

5.2 Test Method and test Procedure:

The EUT was tested according to ANSI C63.4 –2003, The frequency spectrum from 30MHz to 1GHz was investigated. All reading from 30MHz to 1GHz are quasi-peak 0values with a resolution bandwidth of 120KHz. All readings are above 1GHz, peak values with a resolution bandwidth of 1MHz. Measurements were made at 3 meters.

Block diagram of Test setup

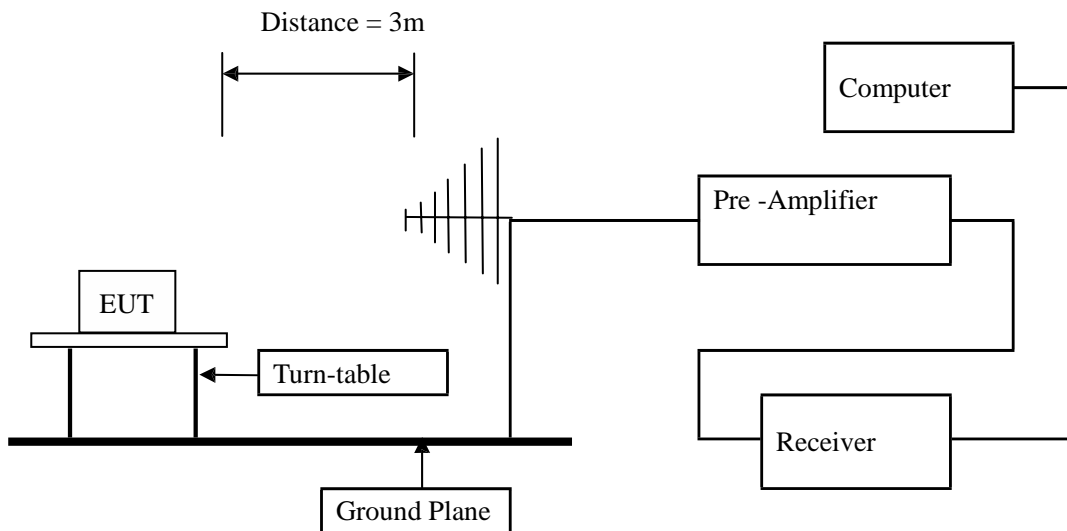

The report refers only to the sample tested and does not apply to the bulk.

This report is issued in confidence to the client and it will be strictly treated as such by the Shenzhen Timeway Technology Consulting Co., Ltd. It may not be reproduced rather in its entirety or in part and it may not be used for advertizing. The client to whom the report is issued may, however, show or send it . or a certified copy there of prepared by the Shenzhen Timeway Technology Consulting co., Ltd to his customer. Supplier or others persons directly concerned. Shenzhen Timeway Technology Consulting co., Ltd will not, without the consent of the client enter into any discussion of correspondence with any third party concerning the contents of the report.

In the event of the improper use of the report. The Shenzhen Timeway Technology Consulting co., Ltd reserves the rights to withdraw it and to adopt any other remedies which may be appropriate.

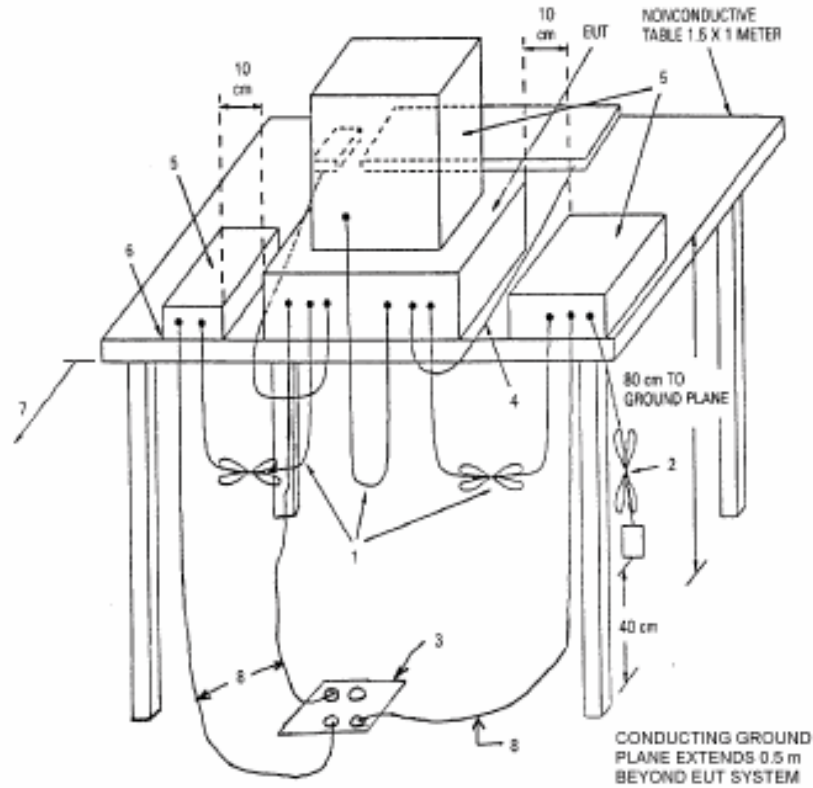

5.3 Radiated Emission Limit

Frequency Range (MHz)	Distance (m)	Field strength (dB μ V/m)
30-88	3	40.00
88-216	3	43.50
216-960	3	46.00
Above 960	3	54.00

Note: The lower limit shall apply at the transition frequencies

5.4 Test result

The frequency spectrum from 30MHz to 1GHz was investigated. All reading from 30MHz to 1GHz are quasi-peak values with a resolution bandwidth of 120KHz. All readings are above 1GHz, peak values with a resolution bandwidth of 1MHz. Measurements were made at 3 meters.

The report refers only to the sample tested and does not apply to the bulk.

This report is issued in confidence to the client and it will be strictly treated as such by the Shenzhen Timeway Technology Consulting Co., Ltd. It may not be reproduced rather in its entirety or in part and it may not be used for adverting. The client to whom the report is issued may, however, show or send it . or a certified copy there of prepared by the Shenzhen Timeway Technology Consulting co., Ltd to his customer. Supplier or others persons directly concerned. Shenzhen Timeway Technology Consulting co., Ltd will not, without the consent of the client enter into any discussion of correspondence with any third party concerning the contents of the report.

In the event of the improper use of the report. The Shenzhen Timeway Technology Consulting co., Ltd reserves the rights to withdraw it and to adopt any other remedies which may be appropriate.



A: Radiated Disturbance In Horizontal (30MHz----1000MHz)

EUT set Condition: Memory
 Adaptor used for test Model No.: ADS-18C-12N 12018GPCU
Level: Class B
Results: PASS

Please refer to following diagram for individual
 Picture of the test

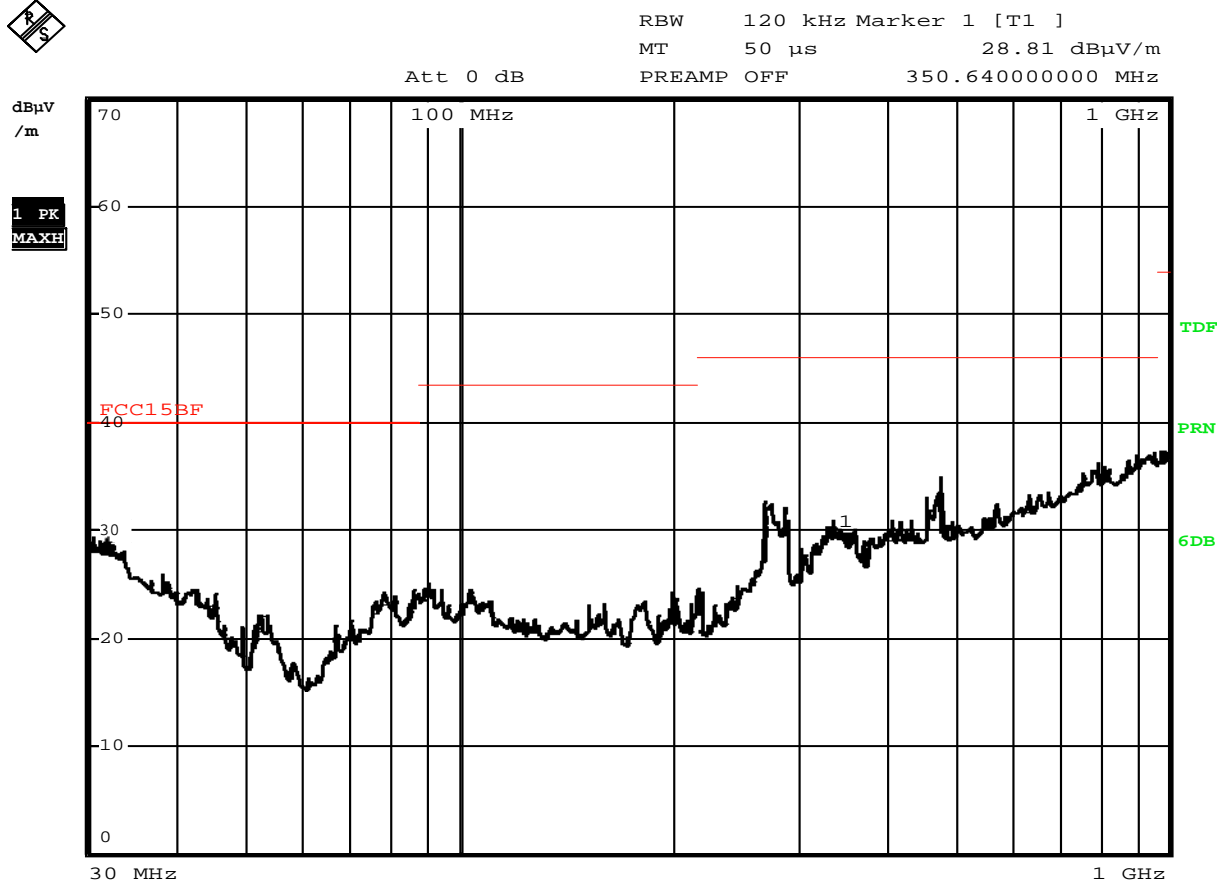

Comment: H
 Date: 25.APR.2009 14:02:47

Frequency (MHz)	Level@3m (dBμV/m)	Antenna Polarity	Limit@3m (dBμV/m)
--	--	H	--
--	--	H	--

-The test data shows much less than the limit, no necessary to take down the records.

The report refers only to the sample tested and does not apply to the bulk.
 This report is issued in confidence to the client and it will be strictly treated as such by the Shenzhen Timeway Technology Consulting Co., Ltd. It may not be reproduced rather in its entirety or in part and it may not be used for advertising. The client to whom the report is issued may, however, show or send it . or a certified copy there of prepared by the Shenzhen Timeway Technology Consulting co., Ltd to his customer. Supplier or others persons directly concerned. Shenzhen Timeway Technology Consulting co., Ltd will not, without the consent of the client enter into any discussion of correspondence with any third party concerning the contents of the report.
 In the event of the improper use of the report. The Shenzhen Timeway Technology Consulting co., Ltd reserves the rights to withdraw it and to adopt any other remedies which may be appropriate.



B: Radiated Disturbance In Vertical (30MHz---1000MHz)

EUT set Condition: Memory
 Adaptor used for test Model No.: ADS-18C-12N 12018GPCU
Level: Class B
Results: PASS

Please refer to following diagram for individual
 Picture of the test

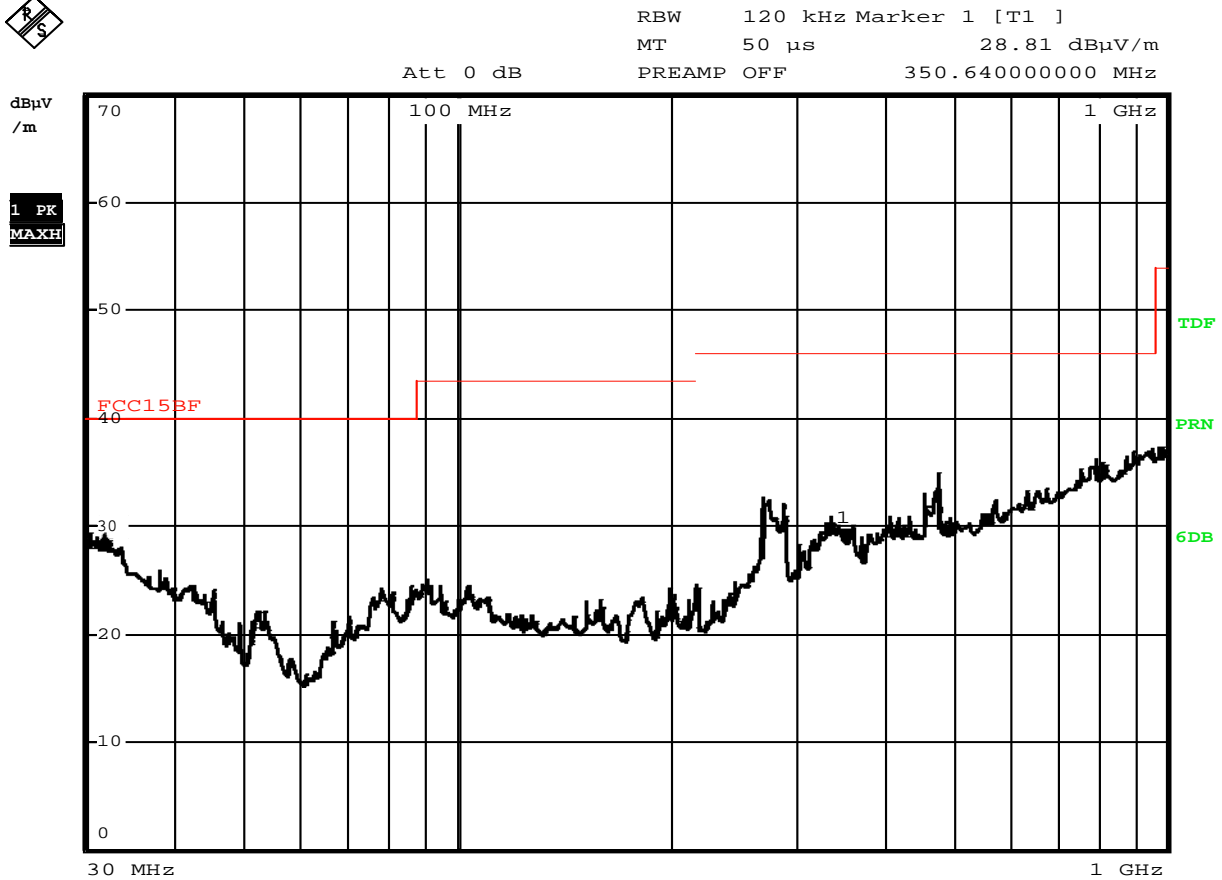

Comment: H
 Date: 25.APR.2009 14:02:47

Frequency (MHz)	Level@3m (dBμV/m)	Antenna Polarity	Limit@3m (dBμV/m)
--	--	V	--
--	--	V	--

-The test data shows much less than the limit, no necessary to take down the records.

The report refers only to the sample tested and does not apply to the bulk.
 This report is issued in confidence to the client and it will be strictly treated as such by the Shenzhen Timeway Technology Consulting Co., Ltd. It may not be reproduced rather in its entirety or in part and it may not be used for advertising. The client to whom the report is issued may, however, show or send it . or a certified copy there of prepared by the Shenzhen Timeway Technology Consulting co., Ltd to his customer. Supplier or others persons directly concerned. Shenzhen Timeway Technology Consulting co., Ltd will not, without the consent of the client enter into any discussion of correspondence with any third party concerning the contents of the report.
 In the event of the improper use of the report. The Shenzhen Timeway Technology Consulting co., Ltd reserves the rights to withdraw it and to adopt any other remedies which may be appropriate.



C: Radiated Disturbance In Horizontal (30MHz----1000MHz)

EUT set Condition: Play SD
 Adaptor used for test Model No.: ADS-18C-12N 12018GPCU
Level: Class B
Results: PASS

Please refer to following diagram for individual
 Picture of the test

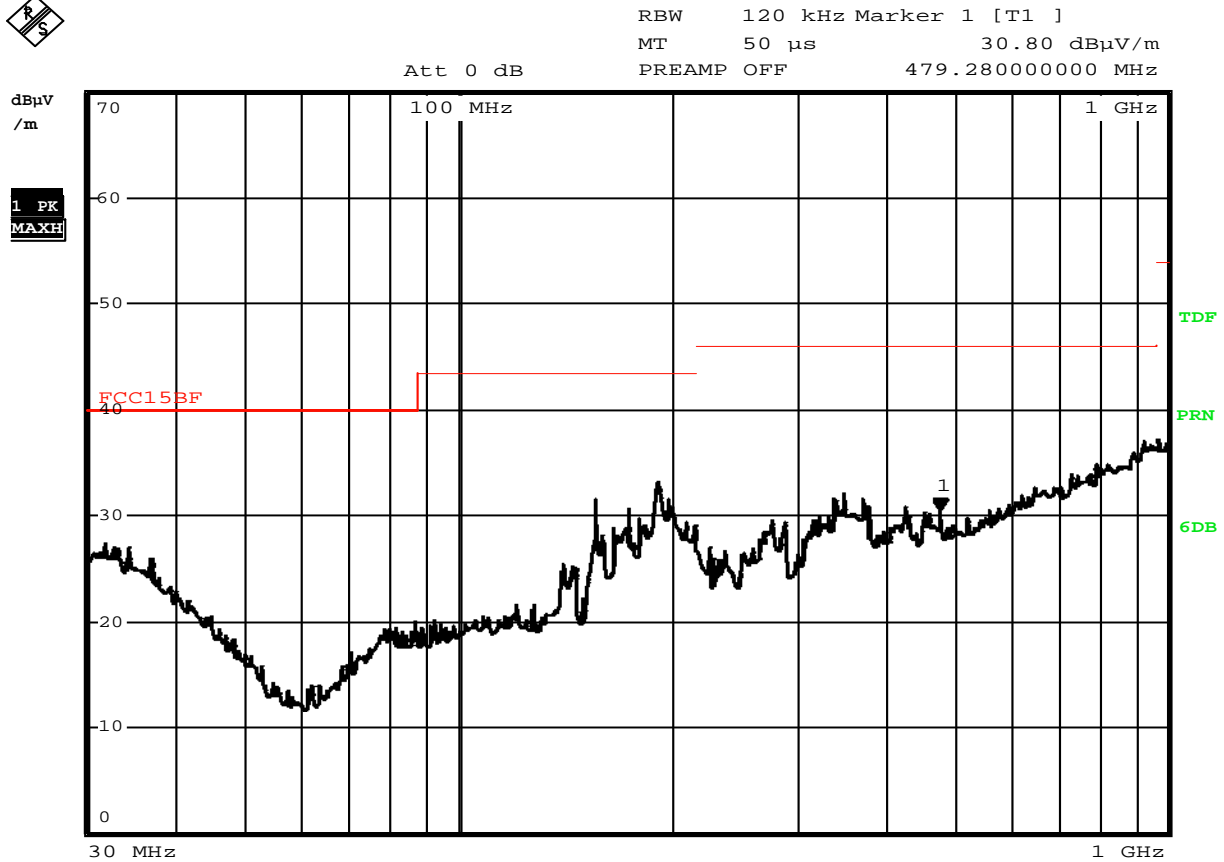

Comment: H
 Date: 25.APR.2009 15:14:48

Frequency (MHz)	Level@3m (dBµV/m)	Antenna Polarity	Limit@3m (dBµV/m)
191.280	33.26	H	43.50

The report refers only to the sample tested and does not apply to the bulk.
 This report is issued in confidence to the client and it will be strictly treated as such by the Shenzhen Timeway Technology Consulting Co., Ltd. It may not be reproduced rather in its entirety or in part and it may not be used for advertising. The client to whom the report is issued may, however, show or send it . or a certified copy there of prepared by the Shenzhen Timeway Technology Consulting co., Ltd to his customer. Supplier or others persons directly concerned. Shenzhen Timeway Technology Consulting co., Ltd will not, without the consent of the client enter into any discussion of correspondence with any third party concerning the contents of the report.
 In the event of the improper use of the report. The Shenzhen Timeway Technology Consulting co., Ltd reserves the rights to withdraw it and to adopt any other remedies which may be appropriate.



D: Radiated Disturbance In Vertical (30MHz---1000MHz)

EUT set Condition: Play SD
 Adaptor used for test Model No.: ADS-18C-12N 12018GPCU
Level: Class B
Results: PASS

Please refer to following diagram for individual
 Picture of the test

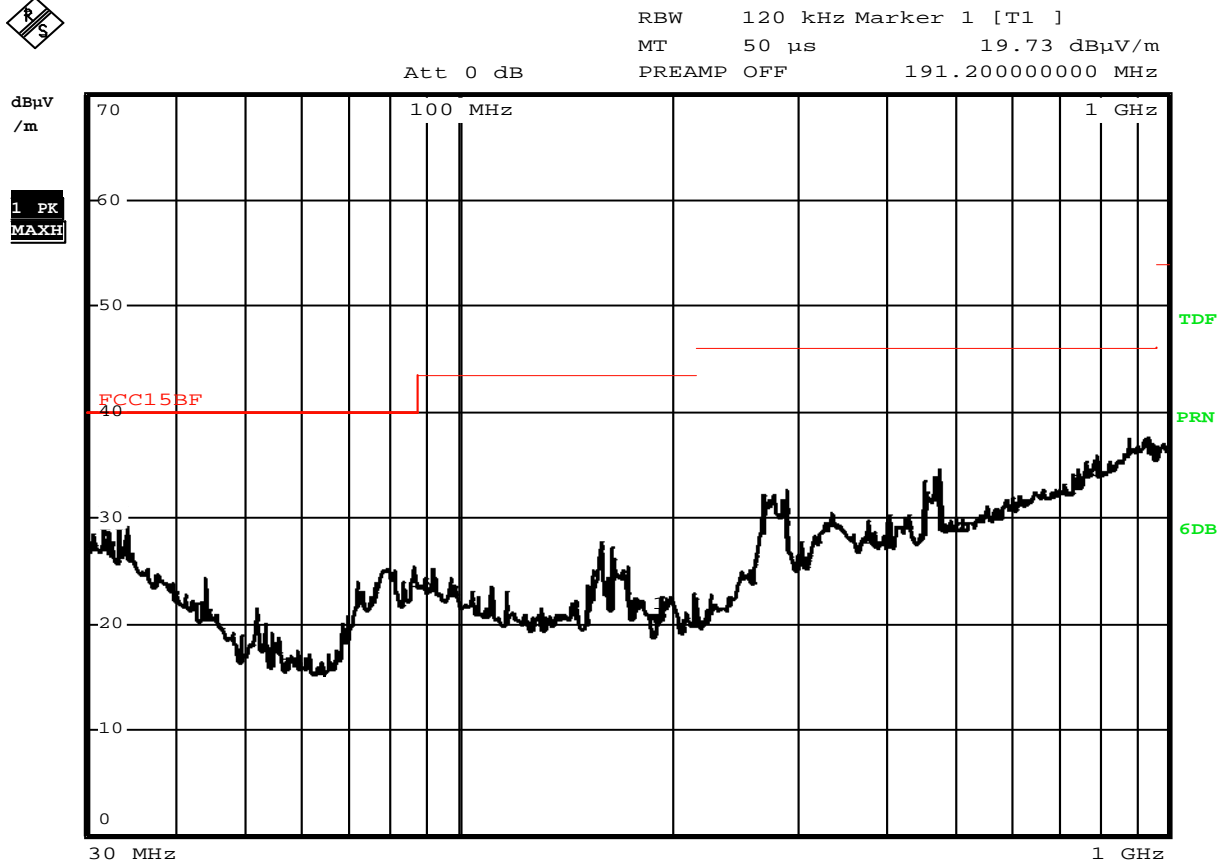

Comment: H
 Date: 25.APR.2009 15:16:34

Frequency (MHz)	Level@3m (dBµV/m)	Antenna Polarity	Limit@3m (dBµV/m)
290.080	32.52	V	46.00
479.120	34.61	V	46.00

The report refers only to the sample tested and does not apply to the bulk.
 This report is issued in confidence to the client and it will be strictly treated as such by the Shenzhen Timeway Technology Consulting Co., Ltd. It may not be reproduced rather in its entirety or in part and it may not be used for advertising. The client to whom the report is issued may, however, show or send it . or a certified copy there of prepared by the Shenzhen Timeway Technology Consulting co., Ltd to his customer. Supplier or others persons directly concerned. Shenzhen Timeway Technology Consulting co., Ltd will not, without the consent of the client enter into any discussion of correspondence with any third party concerning the contents of the report.
 In the event of the improper use of the report. The Shenzhen Timeway Technology Consulting co., Ltd reserves the rights to withdraw it and to adopt any other remedies which may be appropriate.



E: Radiated Disturbance In Horizontal (30MHz----1000MHz)

EUT set Condition: Play CF
 Adaptor used for test Model No.: ADS-18C-12N 12018GPCU
Level: Class B
Results: PASS

Please refer to following diagram for individual
 Picture of the test

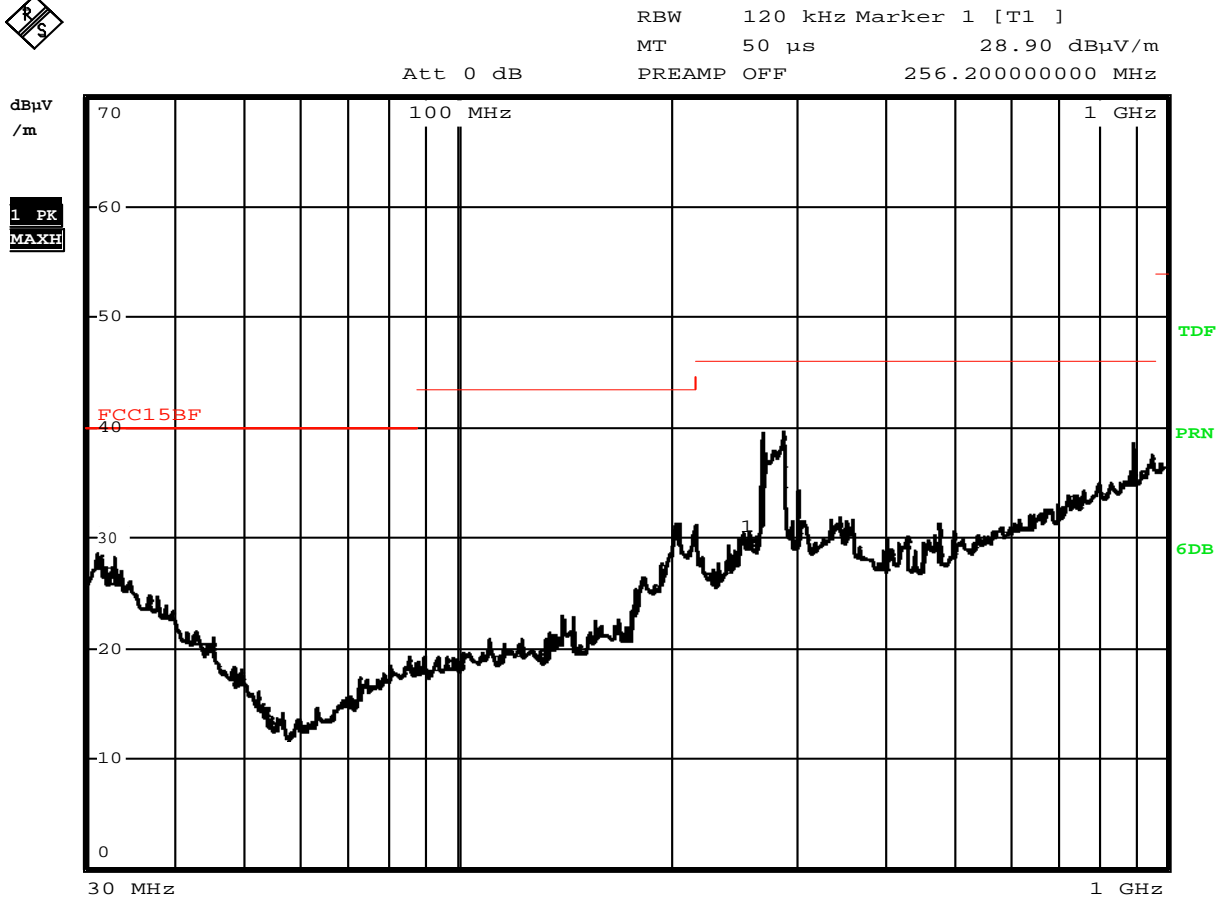

Comment: H
 Date: 25.APR.2009 15:22:09

Frequency (MHz)	Level@3m (dBμV/m)	Antenna Polarity	Limit@3m (dBμV/m)
290.040	33.65	H	46.00
479.280	34.76	H	46.00

The report refers only to the sample tested and does not apply to the bulk.
 This report is issued in confidence to the client and it will be strictly treated as such by the Shenzhen Timeway Technology Consulting Co., Ltd. It may not be reproduced rather in its entirety or in part and it may not be used for advertising. The client to whom the report is issued may, however, show or send it . or a certified copy there of prepared by the Shenzhen Timeway Technology Consulting co., Ltd to his customer. Supplier or others persons directly concerned. Shenzhen Timeway Technology Consulting co., Ltd will not, without the consent of the client enter into any discussion of correspondence with any third party concerning the contents of the report.
 In the event of the improper use of the report. The Shenzhen Timeway Technology Consulting co., Ltd reserves the rights to withdraw it and to adopt any other remedies which may be appropriate.



F: Radiated Disturbance In Vertical (30MHz---1000MHz)

EUT set Condition: Play CF
Adaptor used for test Model No.: ADS-18C-12N 12018GPCU
Level: Class B
Results: PASS

Please refer to following diagram for individual Picture of the test

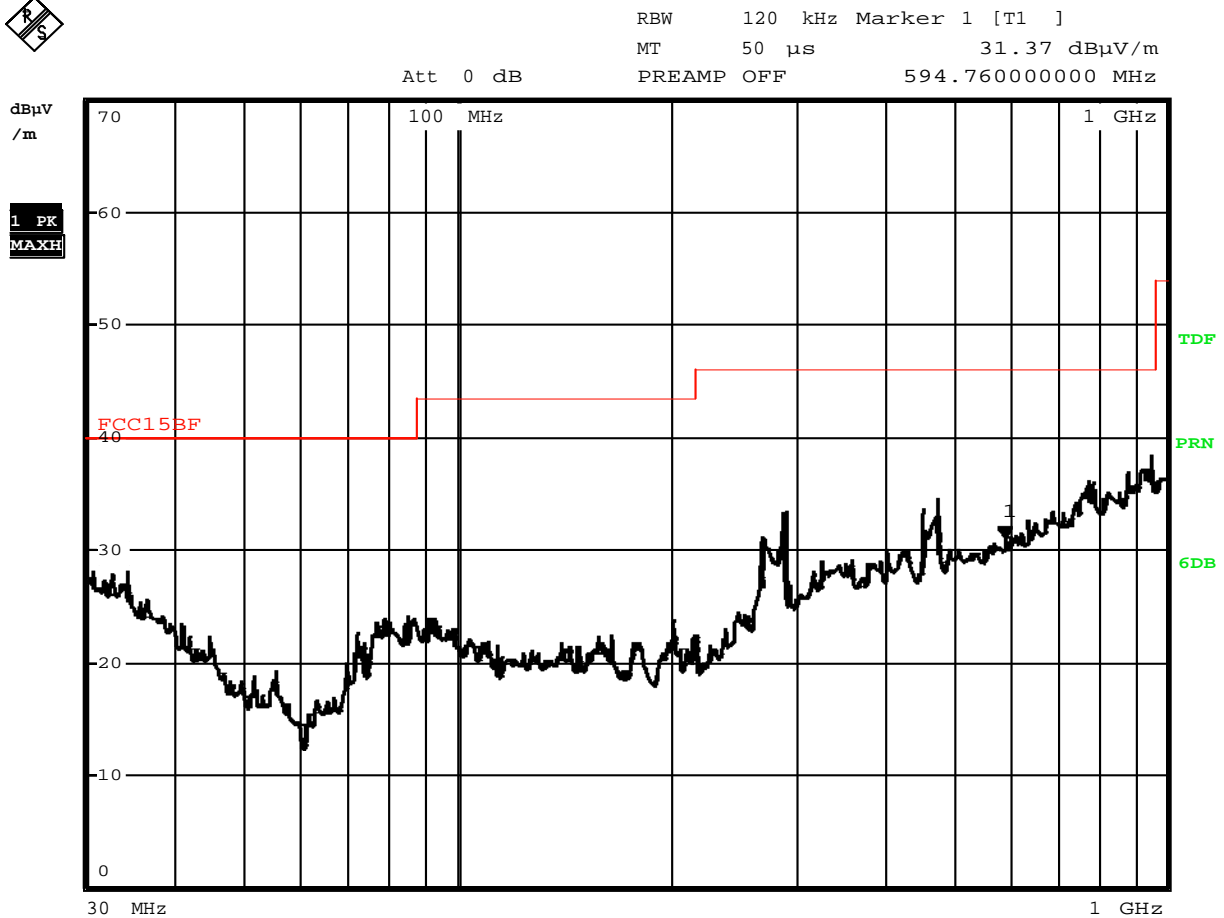

Comment: H
Date: 25.APR.2009 15:19:48

Frequency (MHz)	Level@3m (dBµV/m)	Antenna Polarity	Limit@3m (dBµV/m)
278.280	33.65	V	46.00
289.760	34.76	V	46.00

The report refers only to the sample tested and does not apply to the bulk. This report is issued in confidence to the client and it will be strictly treated as such by the Shenzhen Timeway Technology Consulting Co., Ltd. It may not be reproduced rather in its entirety or in part and it may not be used for advertising. The client to whom the report is issued may, however, show or send it . or a certified copy there of prepared by the Shenzhen Timeway Technology Consulting co., Ltd to his customer. Supplier or others persons directly concerned. Shenzhen Timeway Technology Consulting co., Ltd will not, without the consent of the client enter into any discussion of correspondence with any third party concerning the contents of the report. In the event of the improper use of the report. The Shenzhen Timeway Technology Consulting co., Ltd reserves the rights to withdraw it and to adopt any other remedies which may be appropriate.



G: Radiated Disturbance In Horizontal (30MHz----1000MHz)

EUT set Condition: Play USB
 Adaptor used for test Model No.: ADS-18C-12N 12018GPCU
Level: Class B
Results: PASS

Please refer to following diagram for individual
 Picture of the test

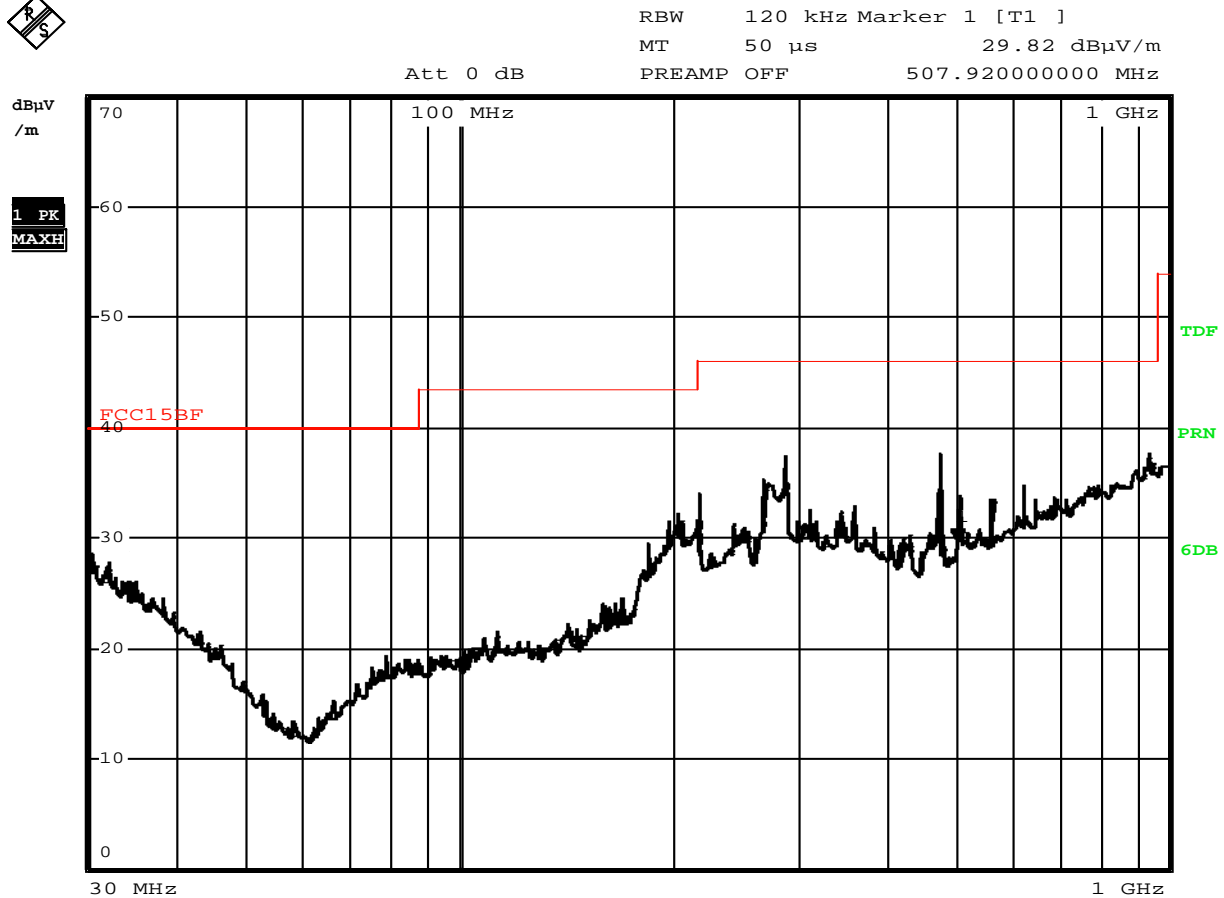

Comment: H
 Date: 25.APR.2009 15:10:50

Frequency (MHz)	Level@3m (dBμV/m)	Antenna Polarity	Limit@3m (dBμV/m)
217.680	34.01	H	43.50
289.760	37.62	H	46.00
480.080	37.76	H	46.00

The report refers only to the sample tested and does not apply to the bulk.
 This report is issued in confidence to the client and it will be strictly treated as such by the Shenzhen Timeway Technology Consulting Co., Ltd. It may not be reproduced rather in its entirety or in part and it may not be used for advertising. The client to whom the report is issued may, however, show or send it . or a certified copy there of prepared by the Shenzhen Timeway Technology Consulting co., Ltd to his customer. Supplier or others persons directly concerned. Shenzhen Timeway Technology Consulting co., Ltd will not, without the consent of the client enter into any discussion of correspondence with any third party concerning the contents of the report.
 In the event of the improper use of the report. The Shenzhen Timeway Technology Consulting co., Ltd reserves the rights to withdraw it and to adopt any other remedies which may be appropriate.



H: Radiated Disturbance In Vertical (30MHz---1000MHz)

EUT set Condition: Play USB
 Adaptor used for test Model No.: ADS-18C-12N 12018GPCU
Level: Class B
Results: PASS

Please refer to following diagram for individual
 Picture of the test

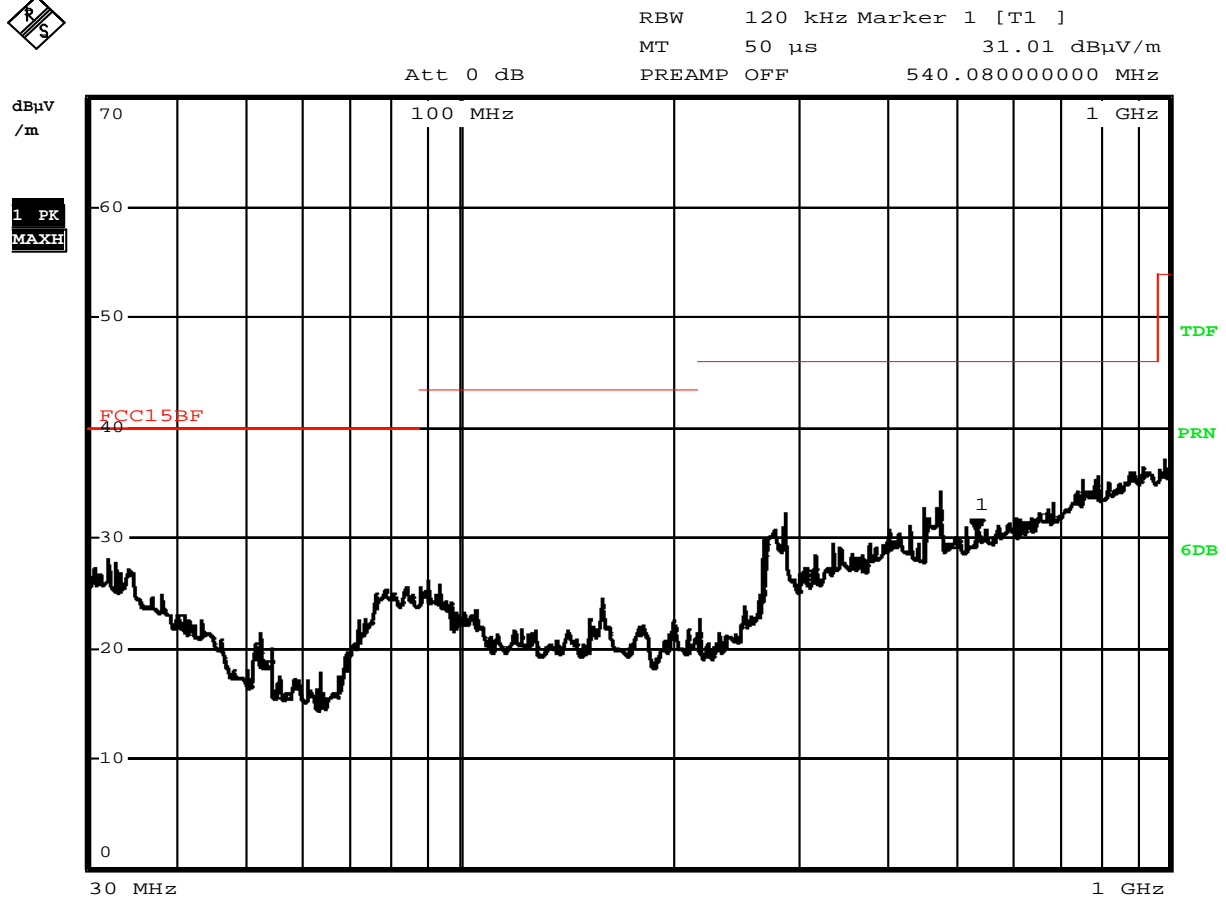

Comment: H
 Date: 25.APR.2009 15:08:42

Frequency (MHz)	Level@3m (dBμV/m)	Antenna Polarity	Limit@3m (dBμV/m)
288.720	32.36	V	46.00
479.280	34.45	V	46.00

The report refers only to the sample tested and does not apply to the bulk.
 This report is issued in confidence to the client and it will be strictly treated as such by the Shenzhen Timeway Technology Consulting Co., Ltd. It may not be reproduced rather in its entirety or in part and it may not be used for advertising. The client to whom the report is issued may, however, show or send it . or a certified copy there of prepared by the Shenzhen Timeway Technology Consulting co., Ltd to his customer. Supplier or others persons directly concerned. Shenzhen Timeway Technology Consulting co., Ltd will not, without the consent of the client enter into any discussion of correspondence with any third party concerning the contents of the report.
 In the event of the improper use of the report. The Shenzhen Timeway Technology Consulting co., Ltd reserves the rights to withdraw it and to adopt any other remedies which may be appropriate.



I Radiated Disturbance In Horizontal (30MHz----1000MHz)

EUT set Condition: Connect to PC
 Adaptor used for test Model No.: ADS-18C-12N 12018GPCU
Level: Class B
Results: PASS

Please refer to following diagram for individual
 Picture of the test

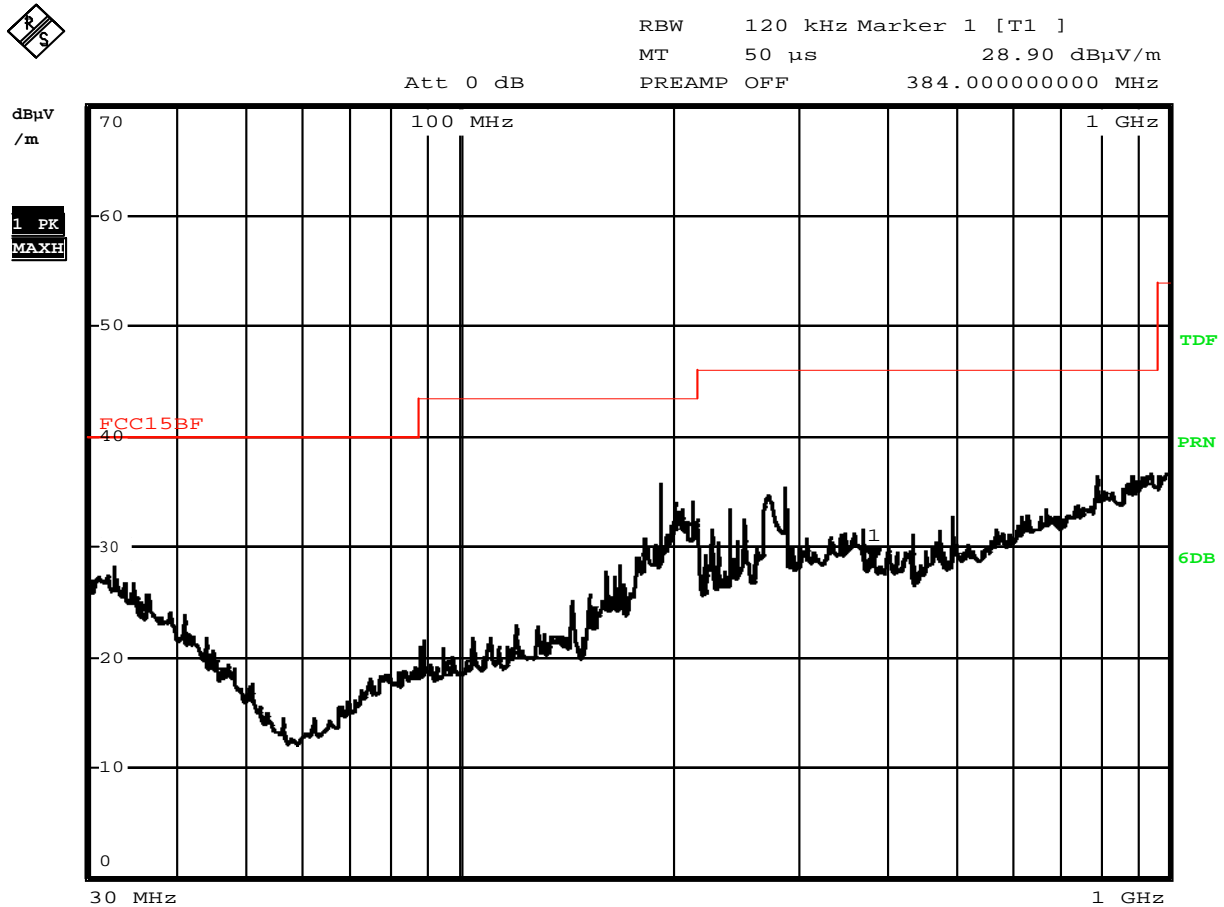

Comment: H
 Date: 25.APR.2009 15:01:48

Frequency (MHz)	Level@3m (dBµV/m)	Antenna Polarity	Limit@3m (dBµV/m)
192.000	35.91	H	43.50
213.920	34.24	H	43.50
273.720	34.87	H	46.00

The report refers only to the sample tested and does not apply to the bulk.
 This report is issued in confidence to the client and it will be strictly treated as such by the Shenzhen Timeway Technology Consulting Co., Ltd. It may not be reproduced rather in its entirety or in part and it may not be used for advertizing. The client to whom the report is issued may, however, show or send it . or a certified copy there of prepared by the Shenzhen Timeway Technology Consulting co., Ltd to his customer. Supplier or others persons directly concerned. Shenzhen Timeway Technology Consulting co., Ltd will not, without the consent of the client enter into any discussion of correspondence with any third party concerning the contents of the report.
 In the event of the improper use of the report. The Shenzhen Timeway Technology Consulting co., Ltd reserves the rights to withdraw it and to adopt any other remedies which may be appropriate.



J Radiated Disturbance In Vertical (30MHz---1000MHz)

EUT set Condition: Connect to PC
 Adaptor used for test Model No.: ADS-18C-12N 12018GPCU
Level: Class B
Results: PASS

Please refer to following diagram for individual
 Picture of the test

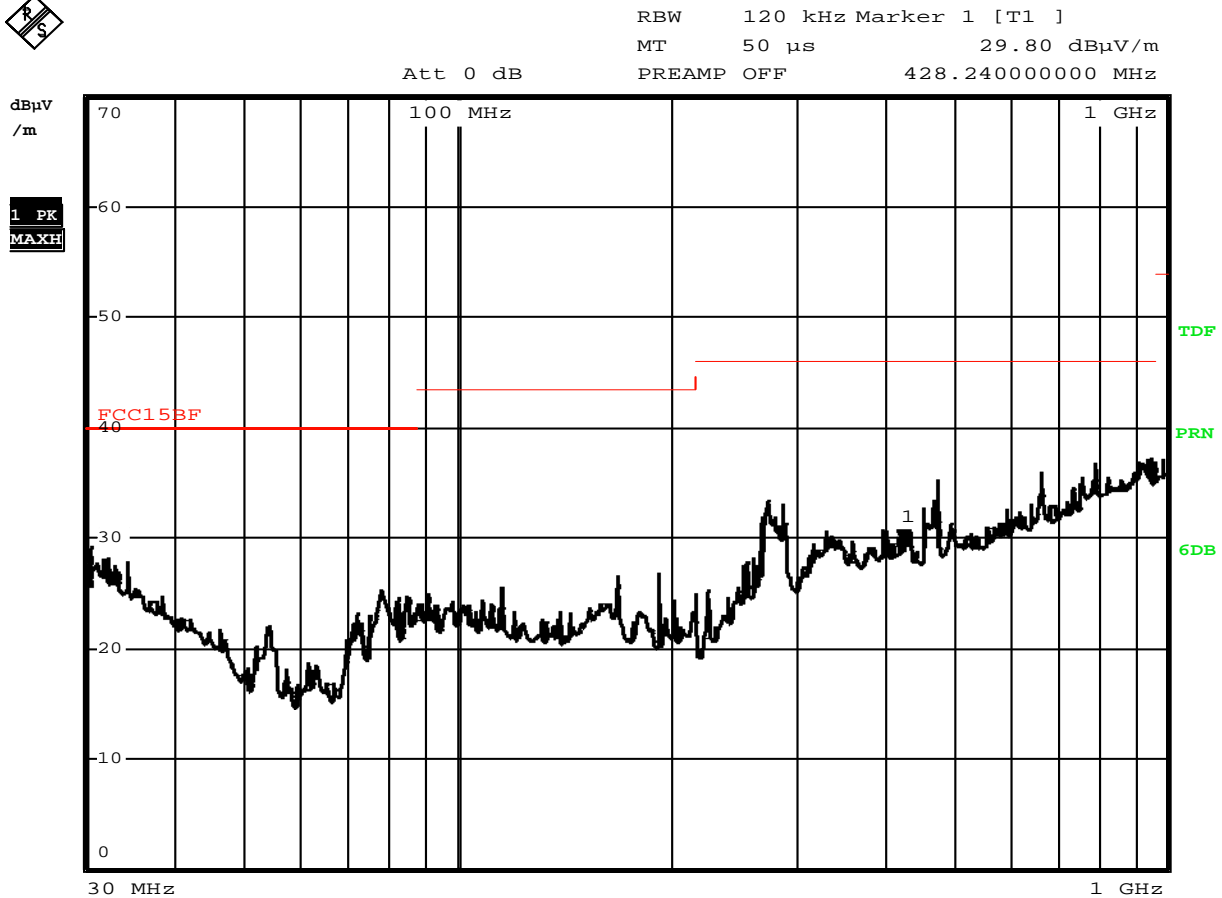

Comment: H
 Date: 25.APR.2009 15:04:31

Frequency (MHz)	Level@3m (dBμV/m)	Antenna Polarity	Limit@3m (dBμV/m)
275.520	33.55	V	46.00
479.440	35.45	V	46.00

The report refers only to the sample tested and does not apply to the bulk.
 This report is issued in confidence to the client and it will be strictly treated as such by the Shenzhen Timeway Technology Consulting Co., Ltd. It may not be reproduced rather in its entirety or in part and it may not be used for advertising. The client to whom the report is issued may, however, show or send it . or a certified copy there of prepared by the Shenzhen Timeway Technology Consulting co., Ltd to his customer. Supplier or others persons directly concerned. Shenzhen Timeway Technology Consulting co., Ltd will not, without the consent of the client enter into any discussion of correspondence with any third party concerning the contents of the report.
 In the event of the improper use of the report. The Shenzhen Timeway Technology Consulting co., Ltd reserves the rights to withdraw it and to adopt any other remedies which may be appropriate.



K Radiated Disturbance In Horizontal (30MHz----1000MHz)

EUT set Condition: Connect to PC
 Adaptor used for test Model No.: XKD-C1500IC12.0-18C-US
Level: Class B
Results: PASS

Please refer to following diagram for individual
 Picture of the test

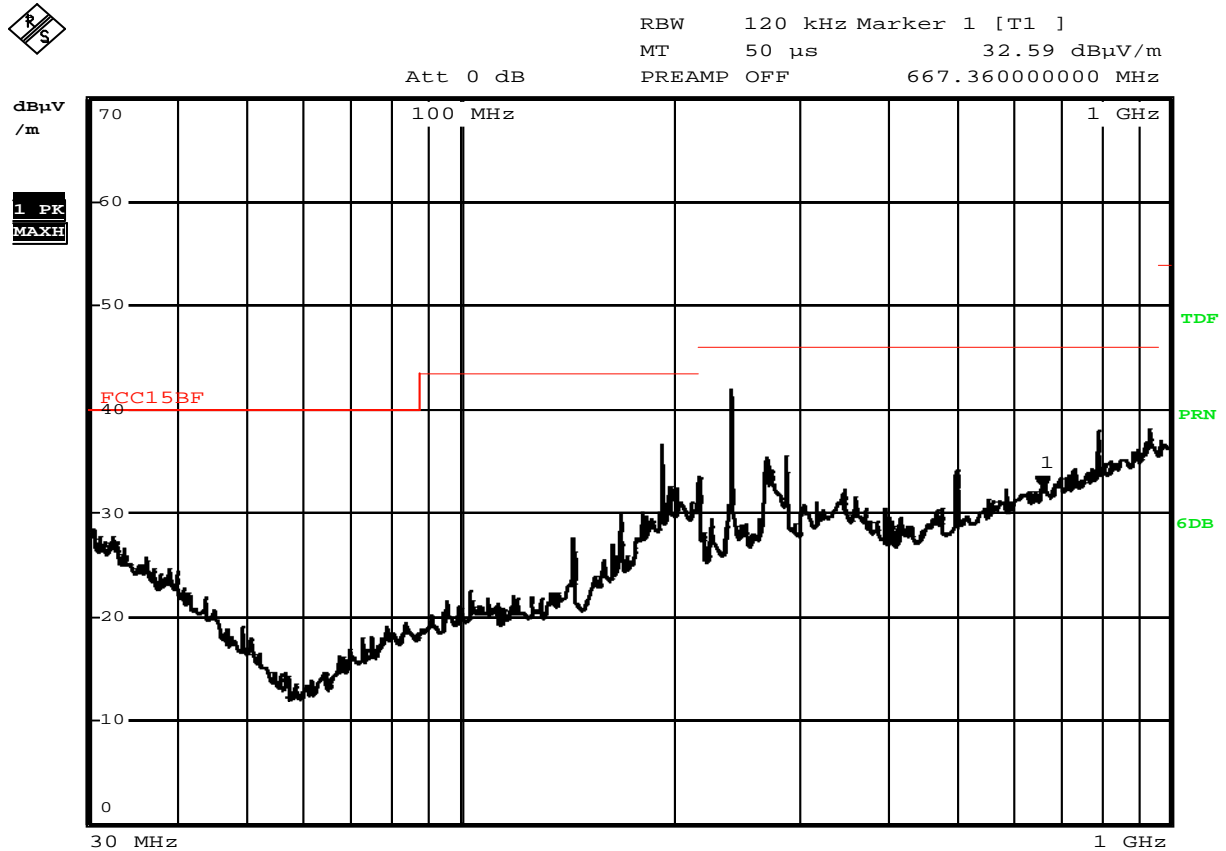

Comment: H
 Date: 25.APR.2009 14:57:06

Frequency (MHz)	Level@3m (dBµV/m)	Antenna Polarity	Limit@3m (dBµV/m)
192.000	36.66	H	43.50
240.080	42.04	H	46.00

The report refers only to the sample tested and does not apply to the bulk.
 This report is issued in confidence to the client and it will be strictly treated as such by the Shenzhen Timeway Technology Consulting Co., Ltd. It may not be reproduced rather in its entirety or in part and it may not be used for advertising. The client to whom the report is issued may, however, show or send it . or a certified copy there of prepared by the Shenzhen Timeway Technology Consulting co., Ltd to his customer. Supplier or others persons directly concerned. Shenzhen Timeway Technology Consulting co., Ltd will not, without the consent of the client enter into any discussion of correspondence with any third party concerning the contents of the report.
 In the event of the improper use of the report. The Shenzhen Timeway Technology Consulting co., Ltd reserves the rights to withdraw it and to adopt any other remedies which may be appropriate.



L Radiated Disturbance In Vertical (30MHz---1000MHz)

EUT set Condition: Connect to PC
 Adaptor used for test Model No.: XKD-C1500IC12.0-18C-US
Level: Class B
Results: PASS

Please refer to following diagram for individual
 Picture of the test

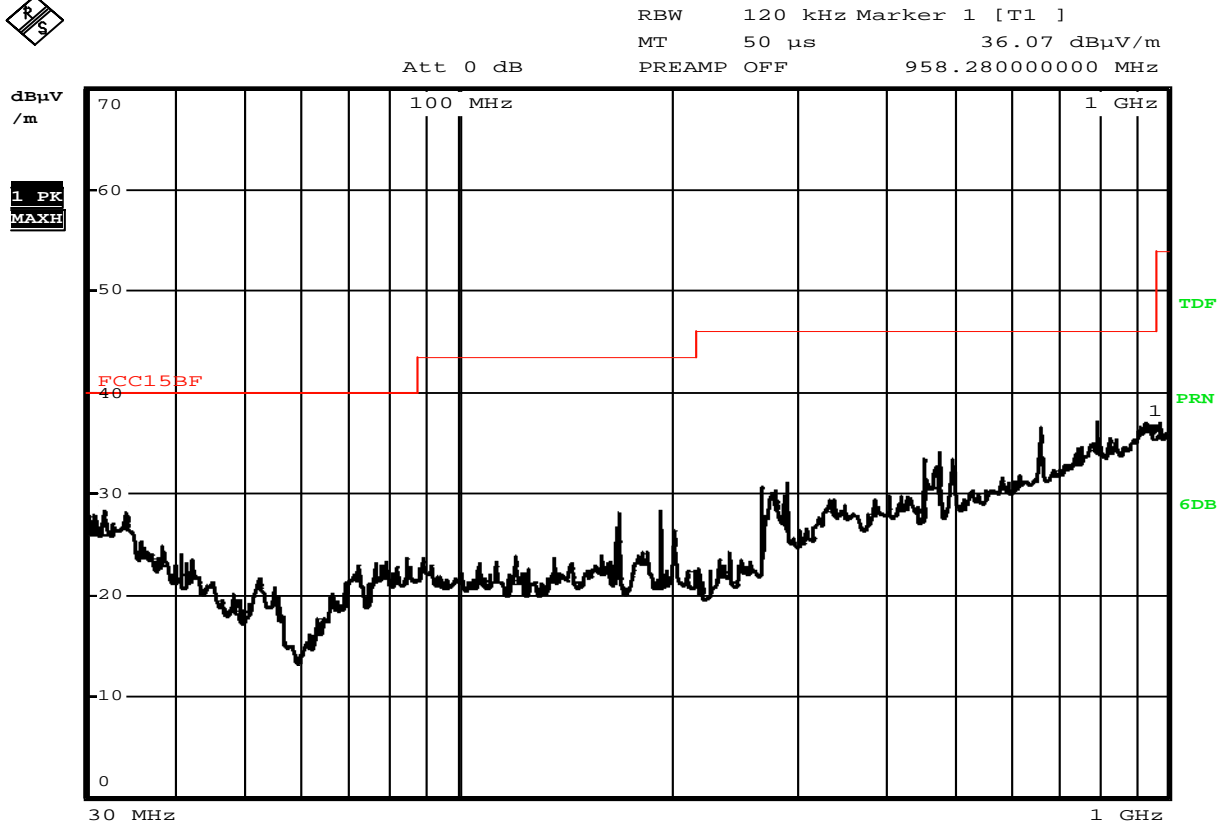

Comment: H
 Date: 25.APR.2009 14:54:17

Frequency (MHz)	Level@3m (dBµV/m)	Antenna Polarity	Limit@3m (dBµV/m)
479.720	34.31	V	46.00
666.600	36.76	V	46.00

The report refers only to the sample tested and does not apply to the bulk.
 This report is issued in confidence to the client and it will be strictly treated as such by the Shenzhen Timeway Technology Consulting Co., Ltd. It may not be reproduced rather in its entirety or in part and it may not be used for advertising. The client to whom the report is issued may, however, show or send it . or a certified copy there of prepared by the Shenzhen Timeway Technology Consulting co., Ltd to his customer. Supplier or others persons directly concerned. Shenzhen Timeway Technology Consulting co., Ltd will not, without the consent of the client enter into any discussion of correspondence with any third party concerning the contents of the report.
 In the event of the improper use of the report. The Shenzhen Timeway Technology Consulting co., Ltd reserves the rights to withdraw it and to adopt any other remedies which may be appropriate.



M Radiated Disturbance In Horizontal (30MHz----1000MHz)

EUT set Condition: Memory
 Adaptor used for test Model No.: XKD-C1500IC12.0-18C-US
Level: Class B
Results: PASS

Please refer to following diagram for individual
 Picture of the test

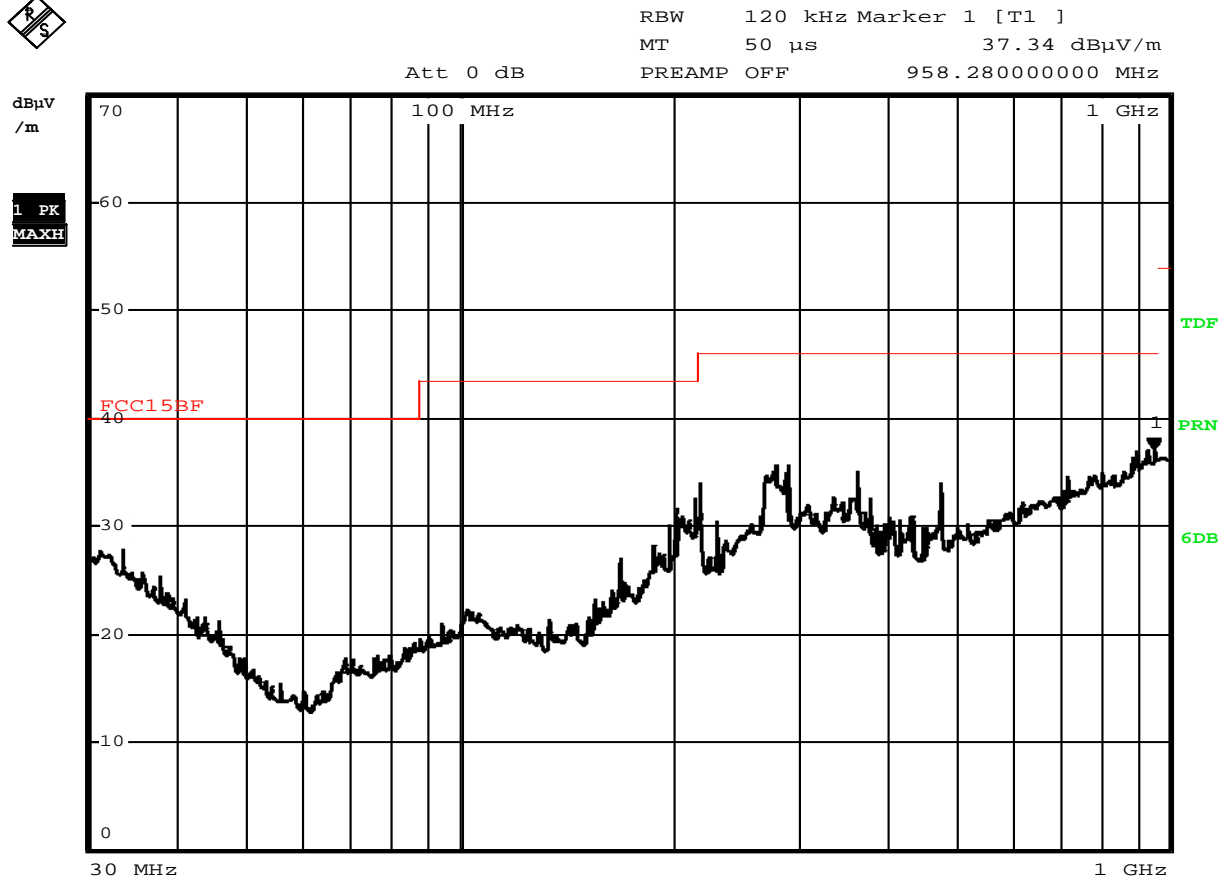

Comment: H
 Date: 25.APR.2009 13:57:25

Frequency (MHz)	Level@3m (dBμV/m)	Antenna Polarity	Limit@3m (dBμV/m)
217.800	34.09	H	43.50
278.800	35.76	H	46.00

The report refers only to the sample tested and does not apply to the bulk.
 This report is issued in confidence to the client and it will be strictly treated as such by the Shenzhen Timeway Technology Consulting Co., Ltd. It may not be reproduced rather in its entirety or in part and it may not be used for advertising. The client to whom the report is issued may, however, show or send it . or a certified copy there of prepared by the Shenzhen Timeway Technology Consulting co., Ltd to his customer. Supplier or others persons directly concerned. Shenzhen Timeway Technology Consulting co., Ltd will not, without the consent of the client enter into any discussion of correspondence with any third party concerning the contents of the report.
 In the event of the improper use of the report. The Shenzhen Timeway Technology Consulting co., Ltd reserves the rights to withdraw it and to adopt any other remedies which may be appropriate.



N Radiated Disturbance In Vertical (30MHz---1000MHz)

EUT set Condition: Memory
 Adaptor used for test Model No.: XKD-C1500IC12.0-18C-US
Level: Class B
Results: PASS

Please refer to following diagram for individual
 Picture of the test

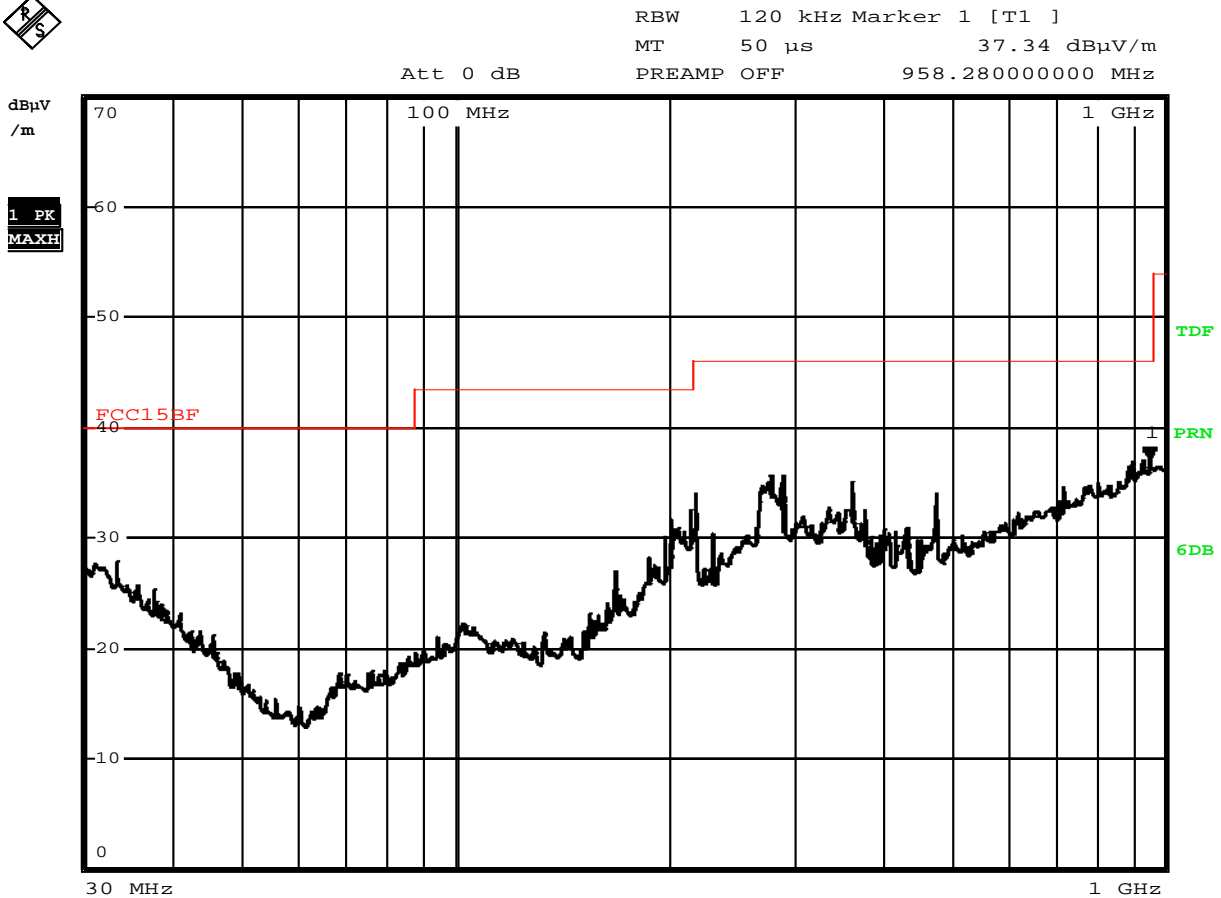

Comment: H
 Date: 25.APR.2009 13:57:25

Frequency (MHz)	Level@3m (dBμV/m)	Antenna Polarity	Limit@3m (dBμV/m)
270.280	32.61	V	46.00
479.440	35.01	V	46.00

The report refers only to the sample tested and does not apply to the bulk.
 This report is issued in confidence to the client and it will be strictly treated as such by the Shenzhen Timeway Technology Consulting Co., Ltd. It may not be reproduced rather in its entirety or in part and it may not be used for advertising. The client to whom the report is issued may, however, show or send it . or a certified copy there of prepared by the Shenzhen Timeway Technology Consulting co., Ltd to his customer. Supplier or others persons directly concerned. Shenzhen Timeway Technology Consulting co., Ltd will not, without the consent of the client enter into any discussion of correspondence with any third party concerning the contents of the report.
 In the event of the improper use of the report. The Shenzhen Timeway Technology Consulting co., Ltd reserves the rights to withdraw it and to adopt any other remedies which may be appropriate.



O Radiated Disturbance In Horizontal (30MHz---1000MHz)

EUT set Condition: Play SD
 Adaptor used for test Model No.: XKD-C1500IC12.0-18C-US
Level: Class B
Results: PASS

Please refer to following diagram for individual
 Picture of the test

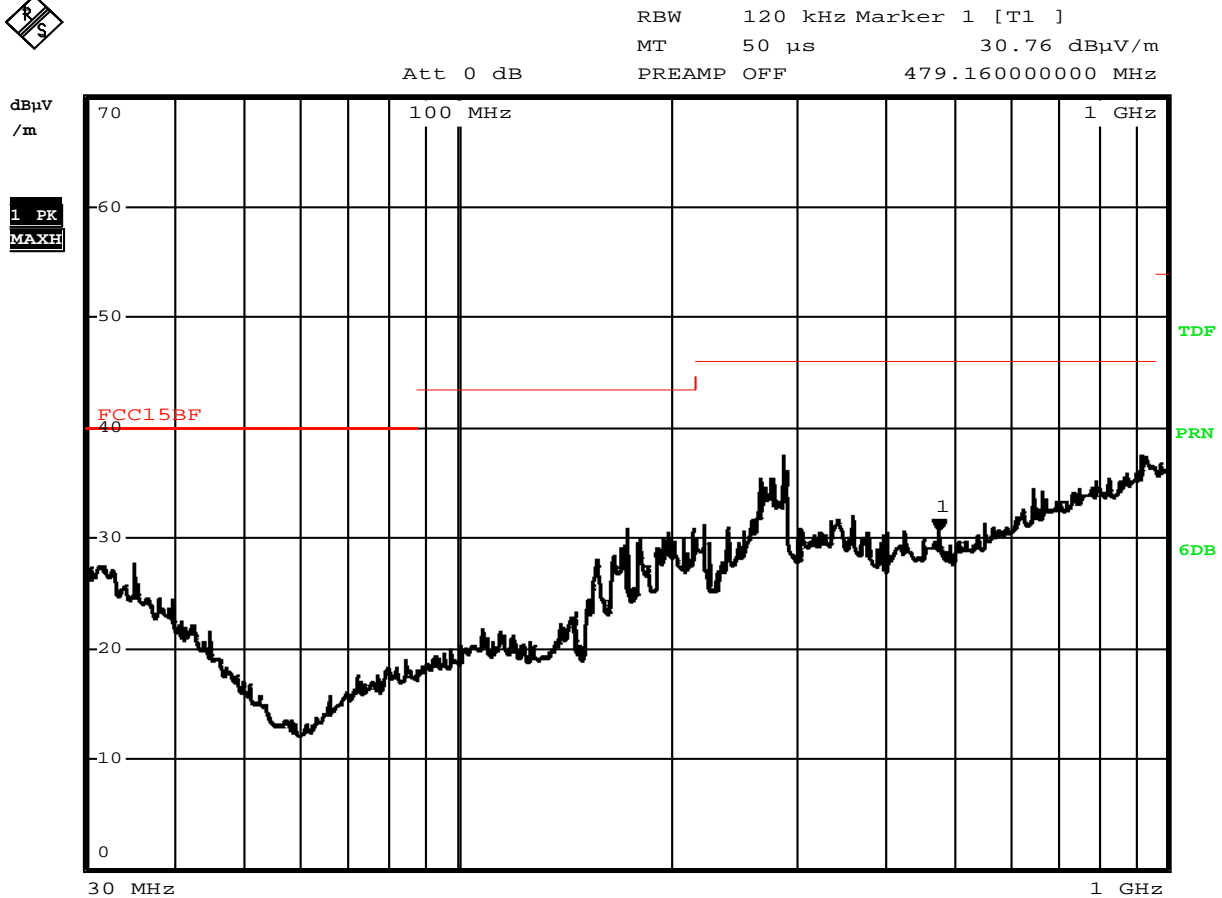

Comment: H
 Date: 25.APR.2009 14:09:18

Frequency (MHz)	Level@3m (dBμV/m)	Antenna Polarity	Limit@3m (dBμV/m)
289.920	37.55	H	46.00

The report refers only to the sample tested and does not apply to the bulk.
 This report is issued in confidence to the client and it will be strictly treated as such by the Shenzhen Timeway Technology Consulting Co., Ltd. It may not be reproduced rather in its entirety or in part and it may not be used for advertising. The client to whom the report is issued may, however, show or send it . or a certified copy there of prepared by the Shenzhen Timeway Technology Consulting co., Ltd to his customer. Supplier or others persons directly concerned. Shenzhen Timeway Technology Consulting co., Ltd will not, without the consent of the client enter into any discussion of correspondence with any third party concerning the contents of the report.
 In the event of the improper use of the report. The Shenzhen Timeway Technology Consulting co., Ltd reserves the rights to withdraw it and to adopt any other remedies which may be appropriate.



P Radiated Disturbance In Vertical (30MHz---1000MHz)

EUT set Condition: Play SD
 Adaptor used for test Model No.: XKD-C1500IC12.0-18C-US
Level: Class B
Results: PASS

Please refer to following diagram for individual
 Picture of the test

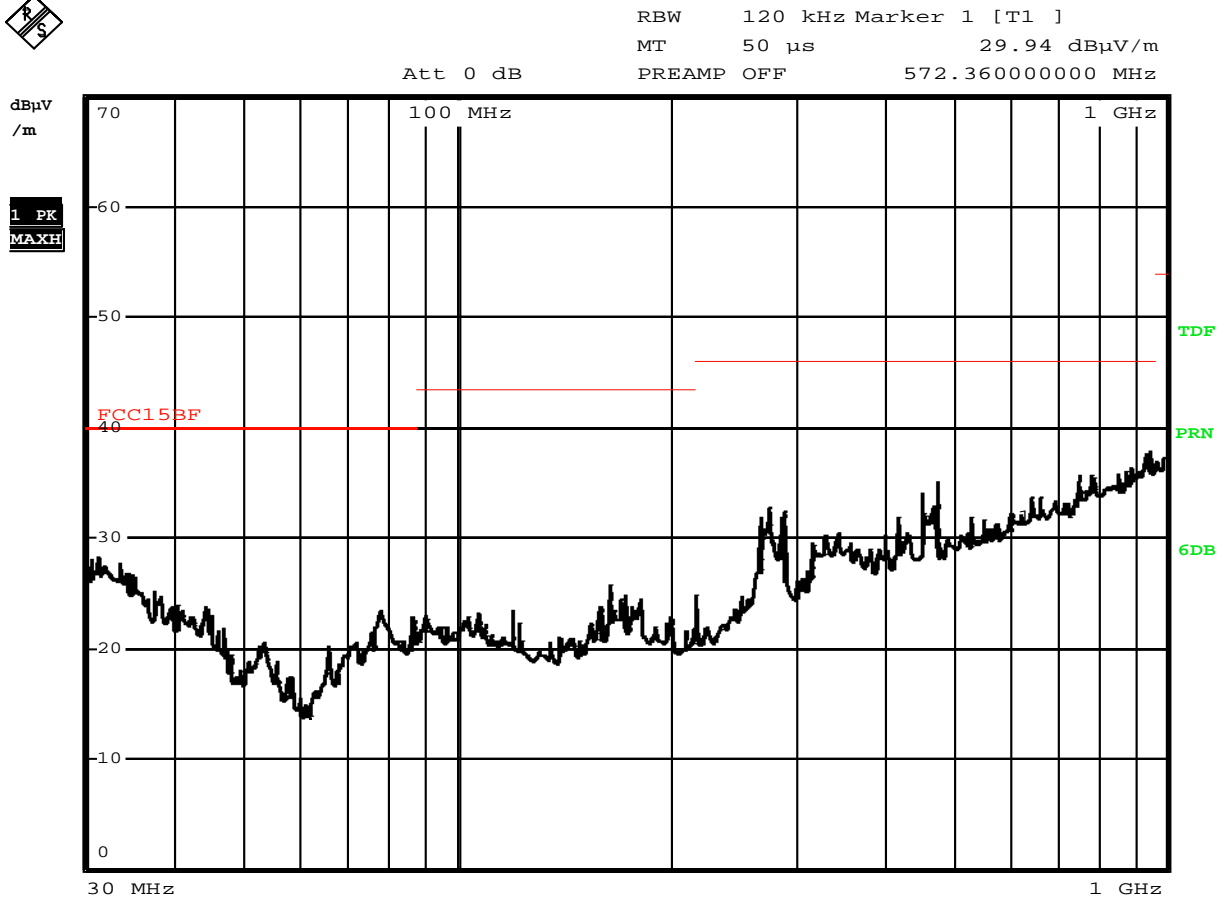

Comment: H
 Date: 25.APR.2009 14:06:40

Frequency (MHz)	Level@3m (dBμV/m)	Antenna Polarity	Limit@3m (dBμV/m)
277.160	32.78	V	46.00
479.280	35.22	V	46.00

The report refers only to the sample tested and does not apply to the bulk.
 This report is issued in confidence to the client and it will be strictly treated as such by the Shenzhen Timeway Technology Consulting Co., Ltd. It may not be reproduced rather in its entirety or in part and it may not be used for advertising. The client to whom the report is issued may, however, show or send it . or a certified copy there of prepared by the Shenzhen Timeway Technology Consulting co., Ltd to his customer. Supplier or others persons directly concerned. Shenzhen Timeway Technology Consulting co., Ltd will not, without the consent of the client enter into any discussion of correspondence with any third party concerning the contents of the report.
 In the event of the improper use of the report. The Shenzhen Timeway Technology Consulting co., Ltd reserves the rights to withdraw it and to adopt any other remedies which may be appropriate.



Q Radiated Disturbance In Horizontal (30MHz----1000MHz)

EUT set Condition: Play USB
 Adaptor used for test Model No.: XKD-C1500IC12.0-18C-US
Level: Class B
Results: PASS

Please refer to following diagram for individual
 Picture of the test

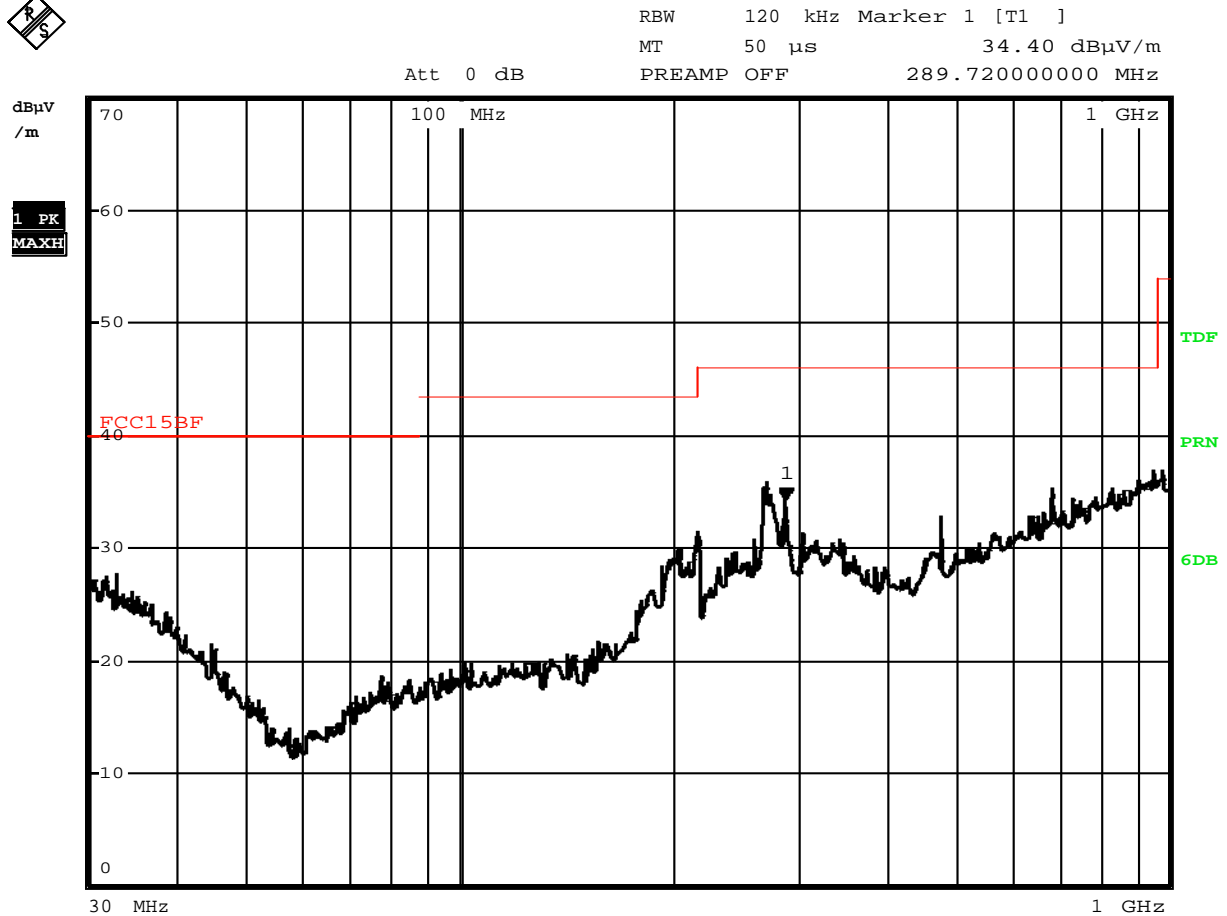

Comment: H
 Date: 25.APR.2009 14:12:55

Frequency (MHz)	Level@3m (dBµV/m)	Antenna Polarity	Limit@3m (dBµV/m)
271.440	35.92	H	46.00

The report refers only to the sample tested and does not apply to the bulk.
 This report is issued in confidence to the client and it will be strictly treated as such by the Shenzhen Timeway Technology Consulting Co., Ltd. It may not be reproduced rather in its entirety or in part and it may not be used for advertising. The client to whom the report is issued may, however, show or send it . or a certified copy there of prepared by the Shenzhen Timeway Technology Consulting co., Ltd to his customer. Supplier or others persons directly concerned. Shenzhen Timeway Technology Consulting co., Ltd will not, without the consent of the client enter into any discussion of correspondence with any third party concerning the contents of the report.
 In the event of the improper use of the report. The Shenzhen Timeway Technology Consulting co., Ltd reserves the rights to withdraw it and to adopt any other remedies which may be appropriate.



R Radiated Disturbance In Vertical (30MHz---1000MHz)

EUT set Condition: Play USB
 Adaptor used for test Model No.: XKD-C1500IC12.0-18C-US
Level: Class B
Results: PASS

Please refer to following diagram for individual
 Picture of the test

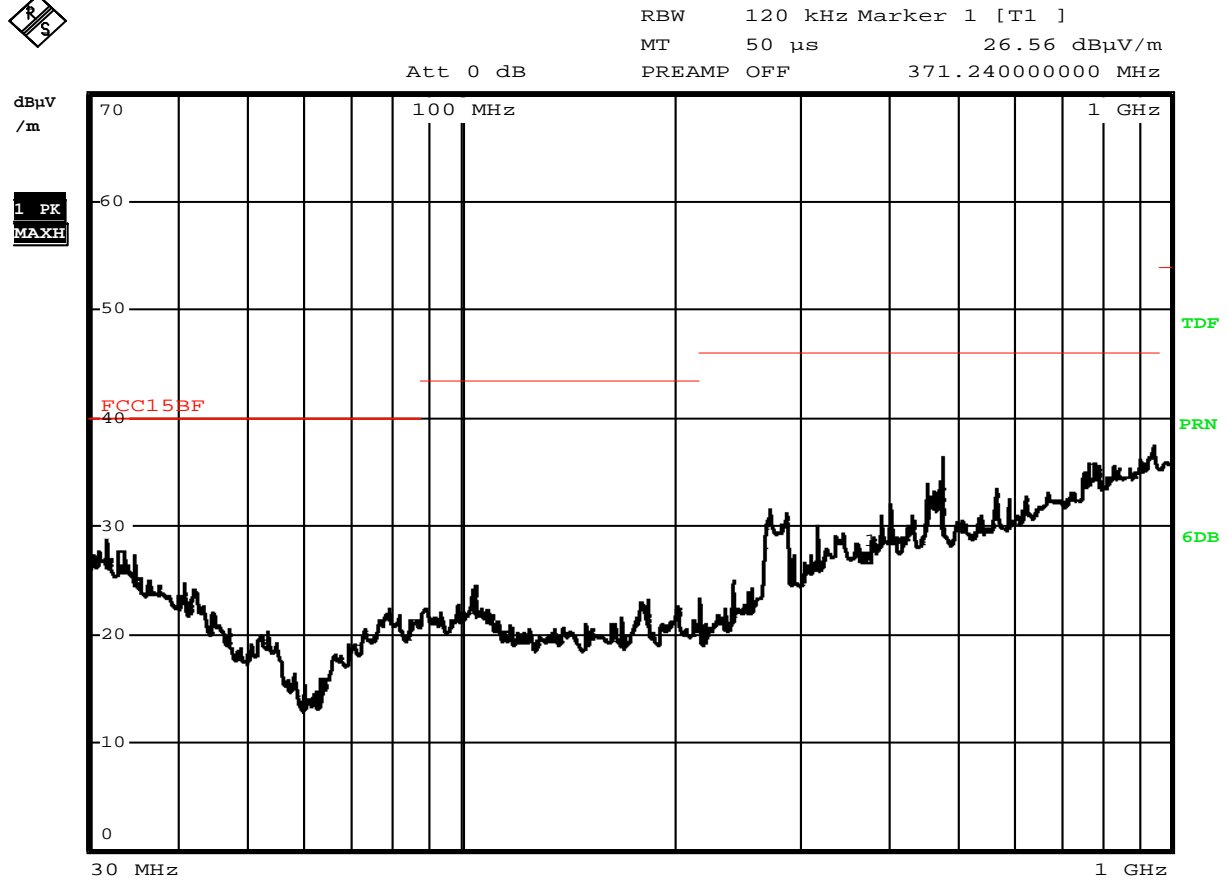

Comment: H
 Date: 25.APR.2009 14:14:08

Frequency (MHz)	Level@3m (dBμV/m)	Antenna Polarity	Limit@3m (dBμV/m)
272.640	31.75	V	46.00
479.280	36.46	V	46.00

The report refers only to the sample tested and does not apply to the bulk.
 This report is issued in confidence to the client and it will be strictly treated as such by the Shenzhen Timeway Technology Consulting Co., Ltd. It may not be reproduced rather in its entirety or in part and it may not be used for advertising. The client to whom the report is issued may, however, show or send it . or a certified copy there of prepared by the Shenzhen Timeway Technology Consulting co., Ltd to his customer. Supplier or others persons directly concerned. Shenzhen Timeway Technology Consulting co., Ltd will not, without the consent of the client enter into any discussion of correspondence with any third party concerning the contents of the report.
 In the event of the improper use of the report. The Shenzhen Timeway Technology Consulting co., Ltd reserves the rights to withdraw it and to adopt any other remedies which may be appropriate.



S Radiated Disturbance In Horizontal (30MHz----1000MHz)

EUT set Condition: Play CF
 Adaptor used for test Model No.: XKD-C1500IC12.0-18C-US
Level: Class B
Results: PASS

Please refer to following diagram for individual
 Picture of the test

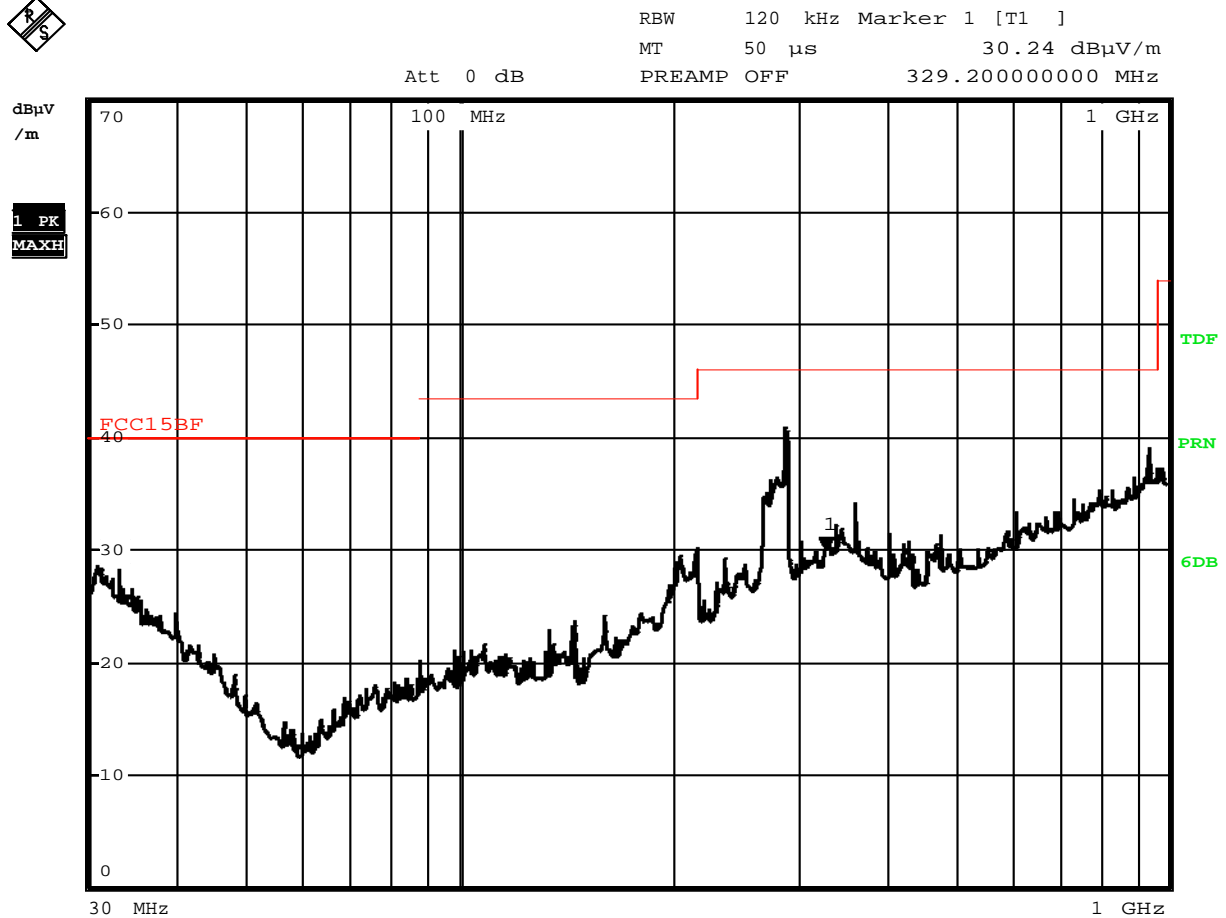

Comment: H
 Date: 25.APR.2009 14:21:17

Frequency (MHz)	Level@3m (dBµV/m)	Antenna Polarity	Limit@3m (dBµV/m)
289.760	41.06	H	46.00

The report refers only to the sample tested and does not apply to the bulk.
 This report is issued in confidence to the client and it will be strictly treated as such by the Shenzhen Timeway Technology Consulting Co., Ltd. It may not be reproduced rather in its entirety or in part and it may not be used for advertizing. The client to whom the report is issued may, however, show or send it . or a certified copy there of prepared by the Shenzhen Timeway Technology Consulting co., Ltd to his customer. Supplier or others persons directly concerned. Shenzhen Timeway Technology Consulting co., Ltd will not, without the consent of the client enter into any discussion of correspondence with any third party concerning the contents of the report.
 In the event of the improper use of the report. The Shenzhen Timeway Technology Consulting co., Ltd reserves the rights to withdraw it and to adopt any other remedies which may be appropriate.



T Radiated Disturbance In Vertical (30MHz---1000MHz)

EUT set Condition: Play CF
 Adaptor used for test Model No.: XKD-C1500IC12.0-18C-US
Level: Class B
Results: PASS

Please refer to following diagram for individual
 Picture of the test

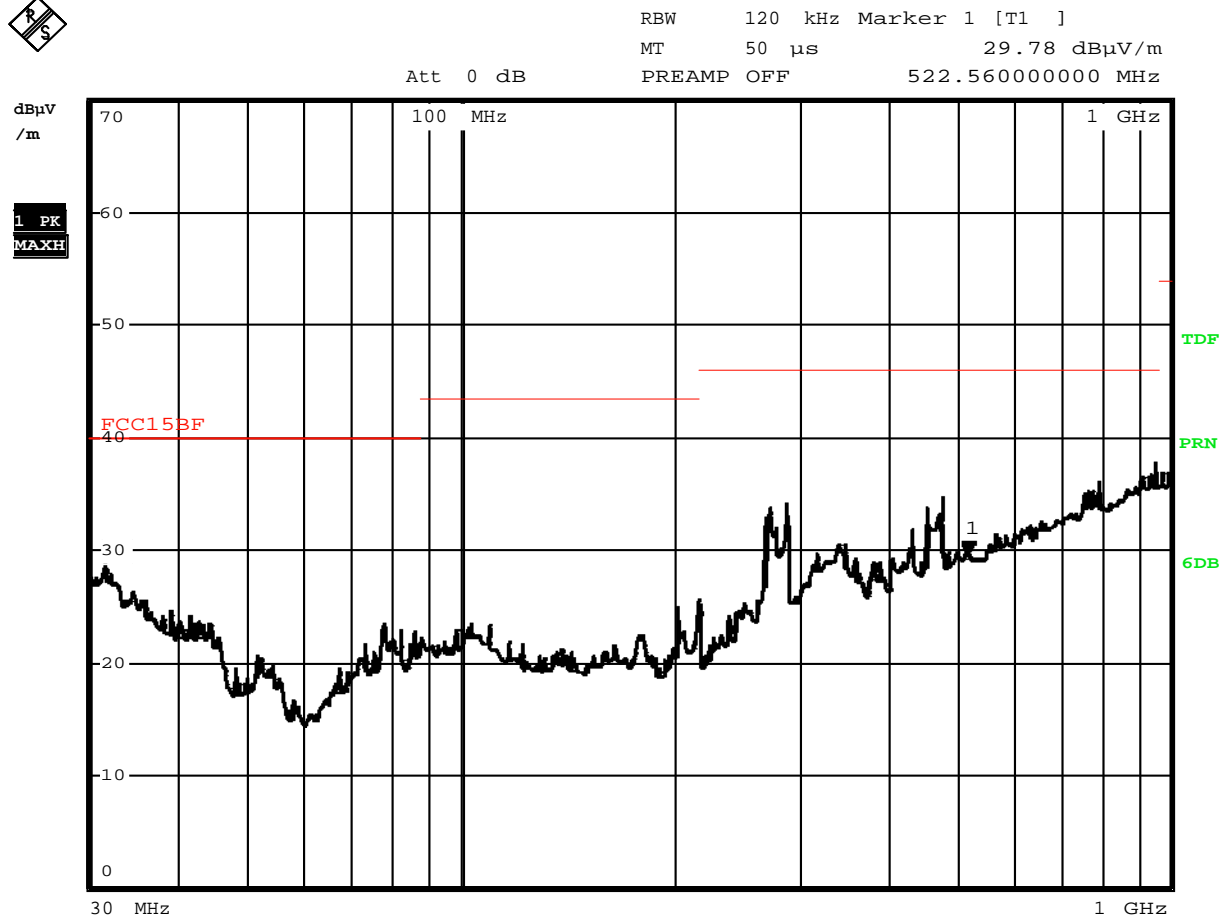

Comment: H
 Date: 25.APR.2009 14:18:39

Frequency (MHz)	Level@3m (dBμV/m)	Antenna Polarity	Limit@3m (dBμV/m)
289.760	34.35	V	46.00
479.720	34.76	V	46.00

The report refers only to the sample tested and does not apply to the bulk.
 This report is issued in confidence to the client and it will be strictly treated as such by the Shenzhen Timeway Technology Consulting Co., Ltd. It may not be reproduced rather in its entirety or in part and it may not be used for advertising. The client to whom the report is issued may, however, show or send it . or a certified copy there of prepared by the Shenzhen Timeway Technology Consulting co., Ltd to his customer. Supplier or others persons directly concerned. Shenzhen Timeway Technology Consulting co., Ltd will not, without the consent of the client enter into any discussion of correspondence with any third party concerning the contents of the report.
 In the event of the improper use of the report. The Shenzhen Timeway Technology Consulting co., Ltd reserves the rights to withdraw it and to adopt any other remedies which may be appropriate.



6.0 FCC ID Label

FCC ID: V37-6226DT-131

This device complies with part 15 of the FCC rules. Operation is subject to the following two conditions (1) this device may not cause harmful interference, and (2) this device must accept any interference received, including interference that may cause undesired operation.

The label must not be a stick-on paper label. The label on these products must be permanently affixed to the product and readily visible at the time of purchase and must last the expected lifetime of the equipment not be readily detachable.

Mark Location:



FCC ID Label Location



7.0 Photo of testing

7.1 Conducted test View—

Connect to PC



The report refers only to the sample tested and does not apply to the bulk.
This report is issued in confidence to the client and it will be strictly treated as such by the Shenzhen Timeway Technology Consulting Co., Ltd. It may not be reproduced rather in its entirety or in part and it may not be used for advertizing. The client to whom the report is issued may, however, show or send it . or a certified copy there of prepared by the Shenzhen Timeway Technology Consulting co., Ltd to his customer. Supplier or others persons directly concerned. Shenzhen Timeway Technology Consulting co., Ltd will not, without the consent of the client enter into any discussion of correspondence with any third party concerning the contents of the report.
In the event of the improper use of the report. The Shenzhen Timeway Technology Consulting co., Ltd reserves the rights to withdraw it and to adopt any other remedies which may be appropriate.



7.2 Radiated emission test view--

Connect to PC

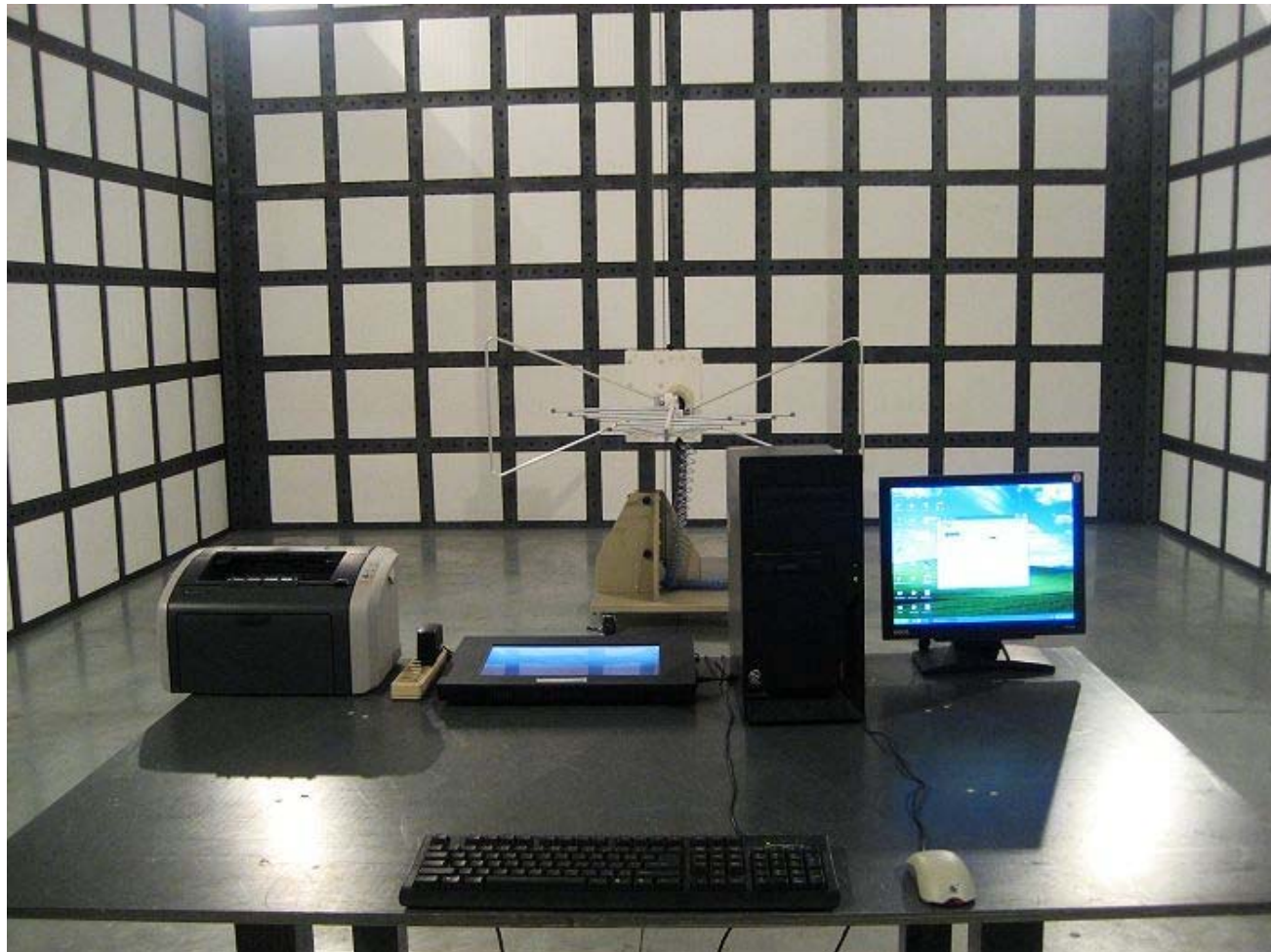

The report refers only to the sample tested and does not apply to the bulk.
This report is issued in confidence to the client and it will be strictly treated as such by the Shenzhen Timeway Technology Consulting Co., Ltd. It may not be reproduced rather in its entirety or in part and it may not be used for advertizing. The client to whom the report is issued may, however, show or send it . or a certified copy there of prepared by the Shenzhen Timeway Technology Consulting co., Ltd to his customer. Supplier or others persons directly concerned. Shenzhen Timeway Technology Consulting co., Ltd will not, without the consent of the client enter into any discussion of correspondence with any third party concerning the contents of the report.
In the event of the improper use of the report. The Shenzhen Timeway Technology Consulting co., Ltd reserves the rights to withdraw it and to adopt any other remedies which may be appropriate.



7.3 Photo for the EUT

Front View



The report refers only to the sample tested and does not apply to the bulk.

This report is issued in confidence to the client and it will be strictly treated as such by the Shenzhen Timeway Technology Consulting Co., Ltd. It may not be reproduced rather in its entirety or in part and it may not be used for advertising. The client to whom the report is issued may, however, show or send it or a certified copy thereof prepared by the Shenzhen Timeway Technology Consulting Co., Ltd to his customer. Supplier or other persons directly concerned. Shenzhen Timeway Technology Consulting Co., Ltd will not, without the consent of the client enter into any discussion of correspondence with any third party concerning the contents of the report.

In the event of the improper use of the report. The Shenzhen Timeway Technology Consulting Co., Ltd reserves the rights to withdraw it and to adopt any other remedies which may be appropriate.

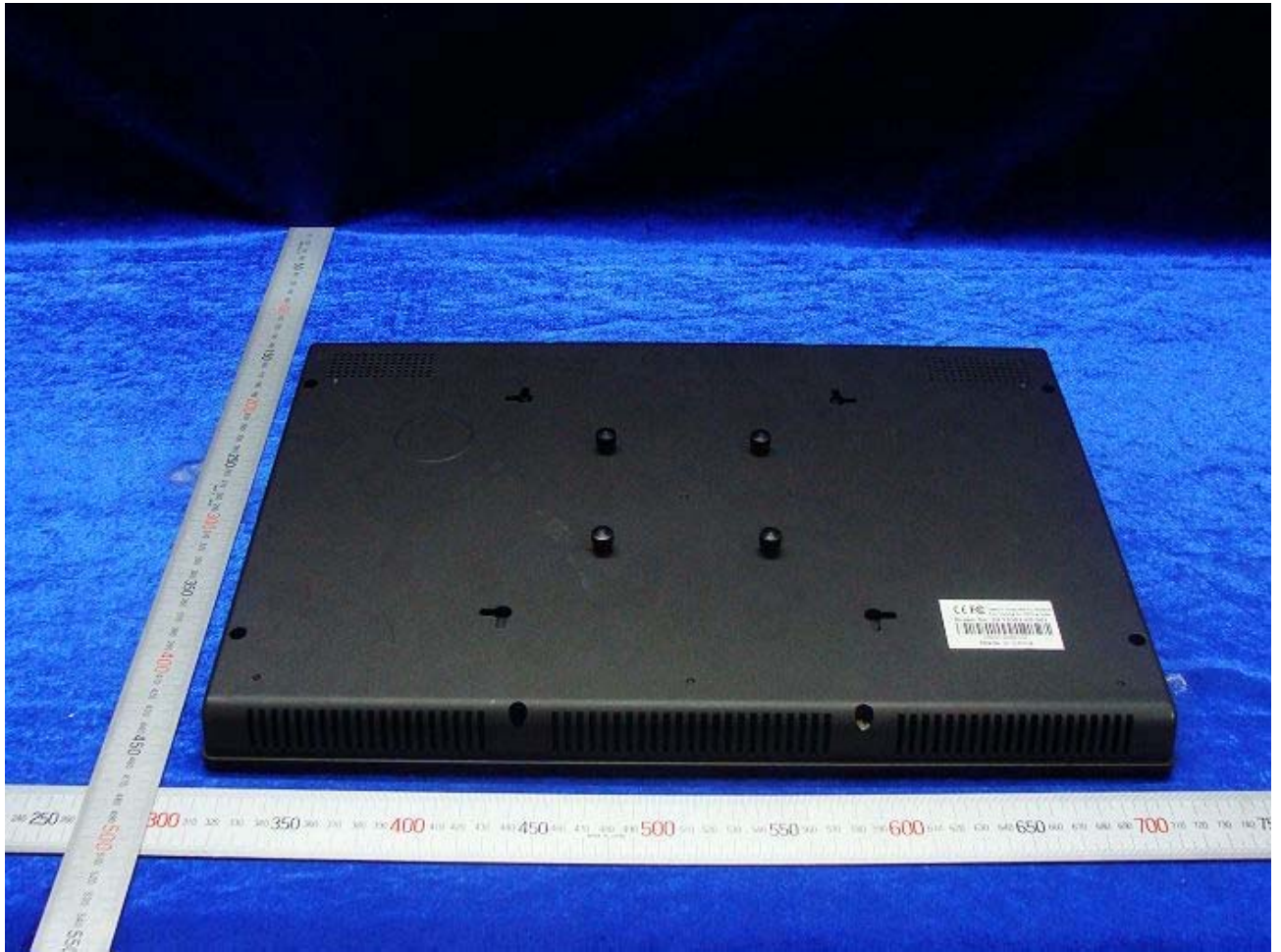

The report refers only to the sample tested and does not apply to the bulk.

This report is issued in confidence to the client and it will be strictly treated as such by the Shenzhen Timeway Technology Consulting Co., Ltd. It may not be reproduced rather in its entirety or in part and it may not be used for adverting. The client to whom the report is issued may, however, show or send it . or a certified copy there of prepared by the Shenzhen Timeway Technology Consulting co., Ltd to his customer. Supplier or others persons directly concerned. Shenzhen Timeway Technology Consulting co., Ltd will not, without the consent of the client enter into any discussion of correspondence with any third party concerning the contents of the report.

In the event of the improper use of the report. The Shenzhen Timeway Technology Consulting co., Ltd reserves the rights to withdraw it and to adopt any other remedies which may be appropriate.



The report refers only to the sample tested and does not apply to the bulk.

This report is issued in confidence to the client and it will be strictly treated as such by the Shenzhen Timeway Technology Consulting Co., Ltd. It may not be reproduced rather in its entirety or in part and it may not be used for advertizing. The client to whom the report is issued may, however, show or send it . or a certified copy there of prepared by the Shenzhen Timeway Technology Consulting co., Ltd to his customer. Supplier or others persons directly concerned. Shenzhen Timeway Technology Consulting co., Ltd will not, without the consent of the client enter into any discussion of correspondence with any third party concerning the contents of the report.

In the event of the improper use of the report. The Shenzhen Timeway Technology Consulting co., Ltd reserves the rights to withdraw it and to adopt any other remedies which may be appropriate.



The report refers only to the sample tested and does not apply to the bulk.

This report is issued in confidence to the client and it will be strictly treated as such by the Shenzhen Timeway Technology Consulting Co., Ltd. It may not be reproduced rather in its entirety or in part and it may not be used for advertizing. The client to whom the report is issued may, however, show or send it . or a certified copy there of prepared by the Shenzhen Timeway Technology Consulting co., Ltd to his customer. Supplier or others persons directly concerned. Shenzhen Timeway Technology Consulting co., Ltd will not, without the consent of the client enter into any discussion of correspondence with any third party concerning the contents of the report.

In the event of the improper use of the report. The Shenzhen Timeway Technology Consulting co., Ltd reserves the rights to withdraw it and to adopt any other remedies which may be appropriate.



The report refers only to the sample tested and does not apply to the bulk.
This report is issued in confidence to the client and it will be strictly treated as such by the Shenzhen Timeway Technology Consulting Co., Ltd. It may not be reproduced rather in its entirety or in part and it may not be used for advertizing. The client to whom the report is issued may, however, show or send it . or a certified copy there of prepared by the Shenzhen Timeway Technology Consulting co., Ltd to his customer. Supplier or others persons directly concerned. Shenzhen Timeway Technology Consulting co., Ltd will not, without the consent of the client enter into any discussion of correspondence with any third party concerning the contents of the report.
In the event of the improper use of the report. The Shenzhen Timeway Technology Consulting co., Ltd reserves the rights to withdraw it and to adopt any other remedies which may be appropriate.

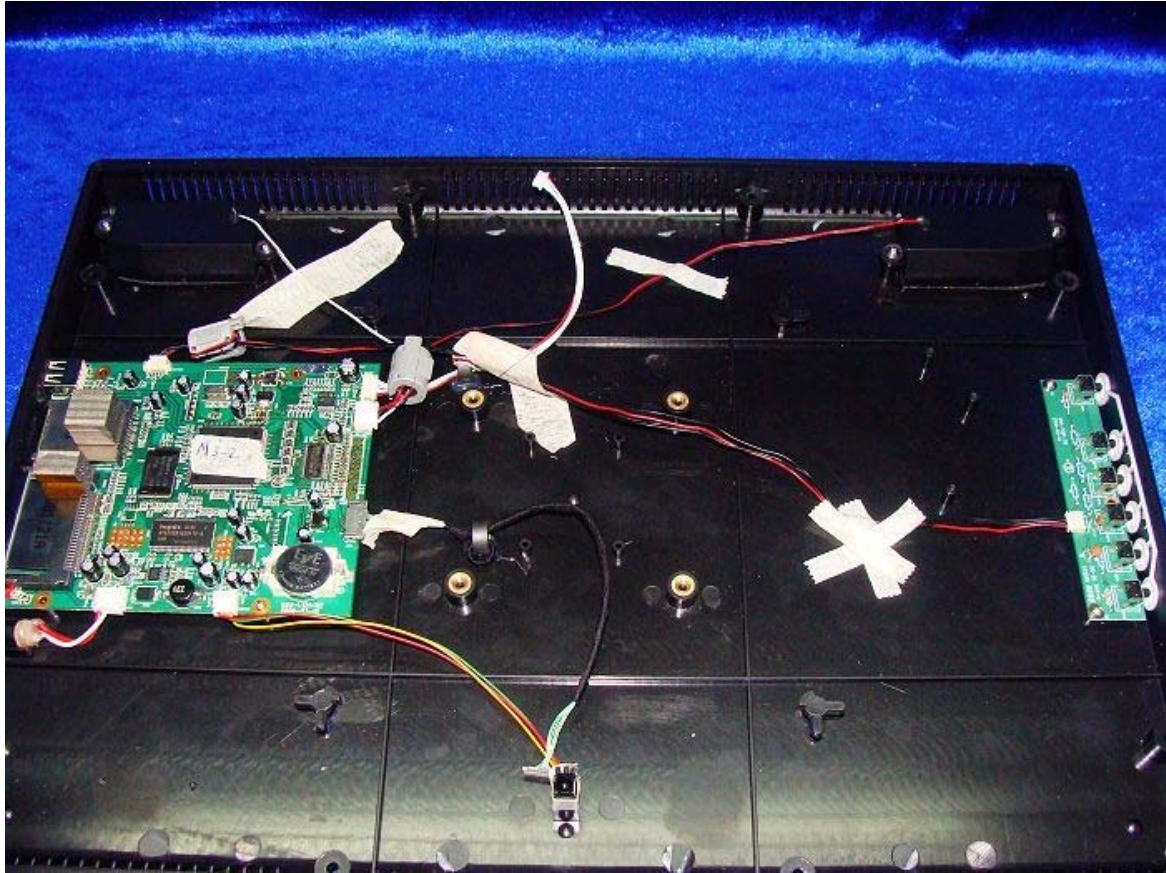

The report refers only to the sample tested and does not apply to the bulk.

This report is issued in confidence to the client and it will be strictly treated as such by the Shenzhen Timeway Technology Consulting Co., Ltd. It may not be reproduced in its entirety or in part and it may not be used for advertising. The client to whom the report is issued may, however, show or send it, or a certified copy thereof prepared by the Shenzhen Timeway Technology Consulting Co., Ltd to his customer, supplier or other persons directly concerned. Shenzhen Timeway Technology Consulting Co., Ltd will not, without the consent of the client enter into any discussion of correspondence with any third party concerning the contents of the report.

In the event of the improper use of the report, the Shenzhen Timeway Technology Consulting Co., Ltd reserves the rights to withdraw it and to adopt any other remedies which may be appropriate.



The report refers only to the sample tested and does not apply to the bulk.

This report is issued in confidence to the client and it will be strictly treated as such by the Shenzhen Timeway Technology Consulting Co., Ltd. It may not be reproduced rather in its entirety or in part and it may not be used for advertising. The client to whom the report is issued may, however, show or send it . or a certified copy there of prepared by the Shenzhen Timeway Technology Consulting co., Ltd to his customer. Supplier or others persons directly concerned. Shenzhen Timeway Technology Consulting co., Ltd will not, without the consent of the client enter into any discussion of correspondence with any third party concerning the contents of the report.

In the event of the improper use of the report. The Shenzhen Timeway Technology Consulting co., Ltd reserves the rights to withdraw it and to adopt any other remedies which may be appropriate.



The report refers only to the sample tested and does not apply to the bulk.

This report is issued in confidence to the client and it will be strictly treated as such by the Shenzhen Timeway Technology Consulting Co., Ltd. It may not be reproduced in its entirety or in part and it may not be used for advertising. The client to whom the report is issued may, however, show or send it, or a certified copy thereof prepared by the Shenzhen Timeway Technology Consulting Co., Ltd to his customer, supplier or other persons directly concerned. Shenzhen Timeway Technology Consulting Co., Ltd will not, without the consent of the client enter into any discussion of correspondence with any third party concerning the contents of the report.

In the event of the improper use of the report, The Shenzhen Timeway Technology Consulting Co., Ltd reserves the rights to withdraw it and to adopt any other remedies which may be appropriate.

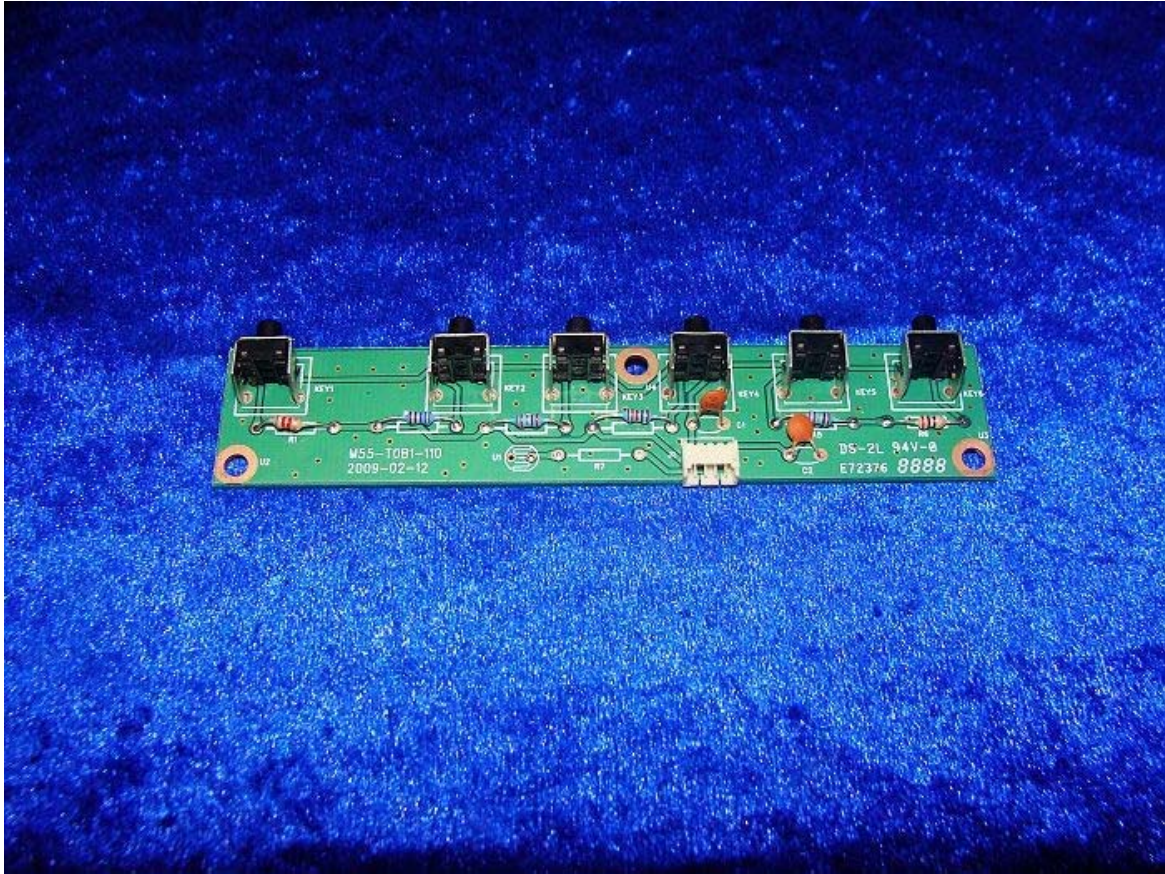

The report refers only to the sample tested and does not apply to the bulk.

This report is issued in confidence to the client and it will be strictly treated as such by the Shenzhen Timeway Technology Consulting Co., Ltd. It may not be reproduced rather in its entirety or in part and it may not be used for advertising. The client to whom the report is issued may, however, show or send it . or a certified copy there of prepared by the Shenzhen Timeway Technology Consulting co., Ltd to his customer. Supplier or others persons directly concerned. Shenzhen Timeway Technology Consulting co., Ltd will not, without the consent of the client enter into any discussion of correspondence with any third party concerning the contents of the report.

In the event of the improper use of the report. The Shenzhen Timeway Technology Consulting co., Ltd reserves the rights to withdraw it and to adopt any other remedies which may be appropriate.

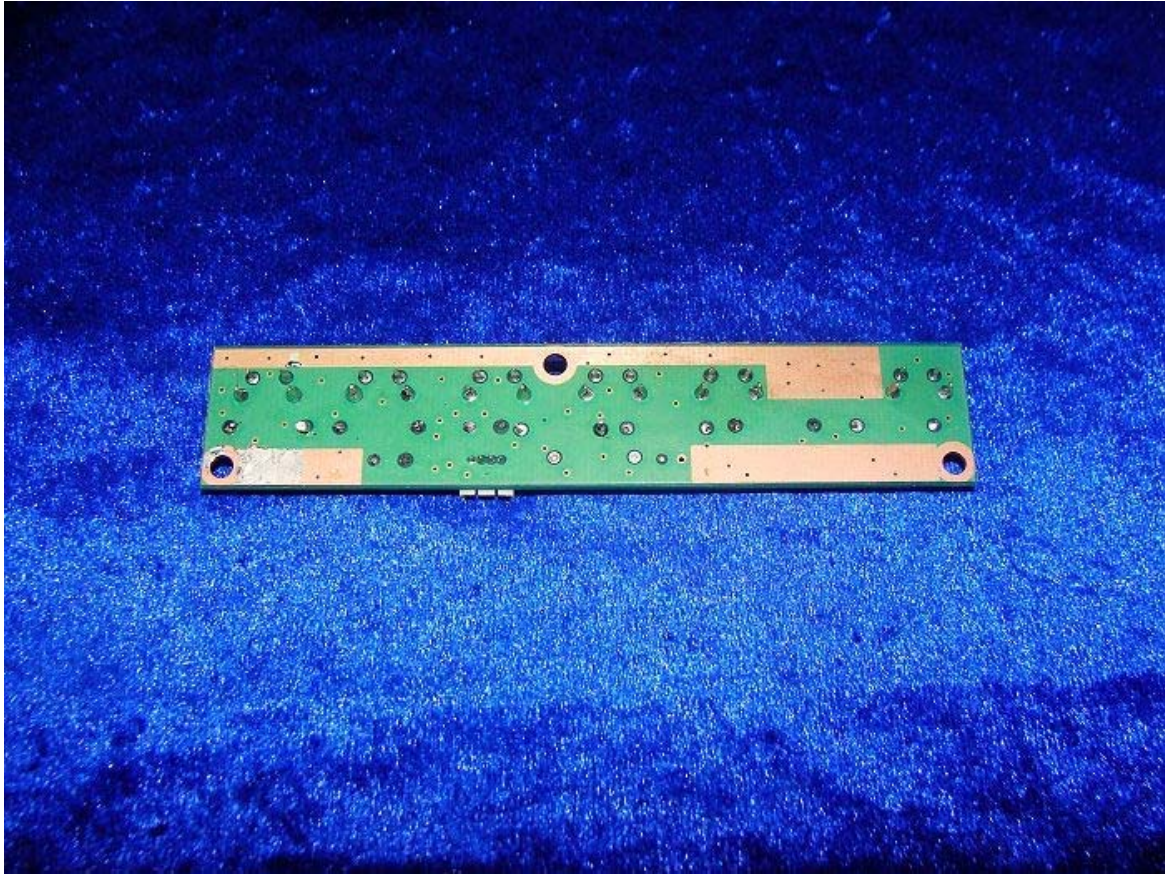

The report refers only to the sample tested and does not apply to the bulk.

This report is issued in confidence to the client and it will be strictly treated as such by the Shenzhen Timeway Technology Consulting Co., Ltd. It may not be reproduced rather in its entirety or in part and it may not be used for advertizing. The client to whom the report is issued may, however, show or send it . or a certified copy there of prepared by the Shenzhen Timeway Technology Consulting co., Ltd to his customer. Supplier or others persons directly concerned. Shenzhen Timeway Technology Consulting co., Ltd will not, without the consent of the client enter into any discussion of correspondence with any third party concerning the contents of the report.

In the event of the improper use of the report. The Shenzhen Timeway Technology Consulting co., Ltd reserves the rights to withdraw it and to adopt any other remedies which may be appropriate.



The report refers only to the sample tested and does not apply to the bulk.

This report is issued in confidence to the client and it will be strictly treated as such by the Shenzhen Timeway Technology Consulting Co., Ltd. It may not be reproduced rather in its entirety or in part and it may not be used for advertising. The client to whom the report is issued may, however, show or send it . or a certified copy there of prepared by the Shenzhen Timeway Technology Consulting co., Ltd to his customer. Supplier or others persons directly concerned. Shenzhen Timeway Technology Consulting co., Ltd will not, without the consent of the client enter into any discussion of correspondence with any third party concerning the contents of the report.

In the event of the improper use of the report. The Shenzhen Timeway Technology Consulting co., Ltd reserves the rights to withdraw it and to adopt any other remedies which may be appropriate.

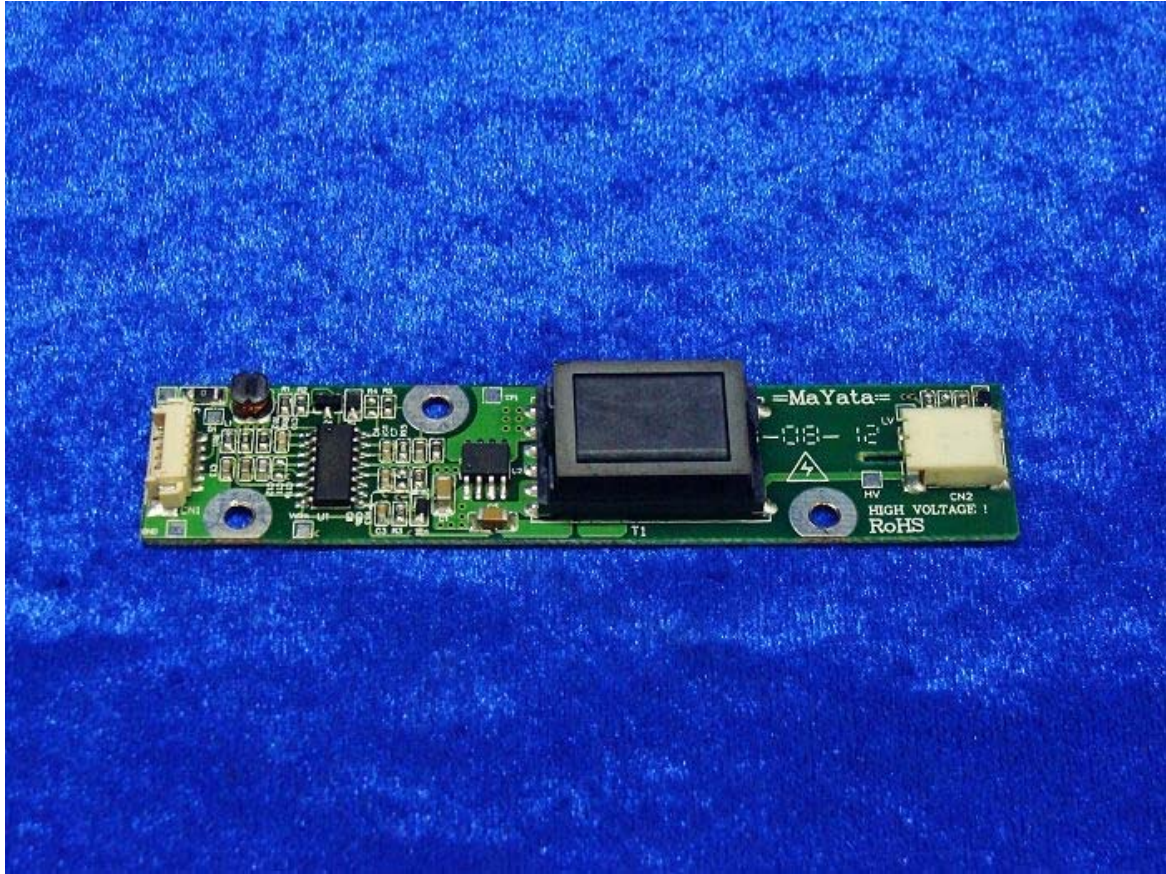

The report refers only to the sample tested and does not apply to the bulk.

This report is issued in confidence to the client and it will be strictly treated as such by the Shenzhen Timeway Technology Consulting Co., Ltd. It may not be reproduced rather in its entirety or in part and it may not be used for advertising. The client to whom the report is issued may, however, show or send it . or a certified copy there of prepared by the Shenzhen Timeway Technology Consulting co., Ltd to his customer. Supplier or others persons directly concerned. Shenzhen Timeway Technology Consulting co., Ltd will not, without the consent of the client enter into any discussion of correspondence with any third party concerning the contents of the report.

In the event of the improper use of the report. The Shenzhen Timeway Technology Consulting co., Ltd reserves the rights to withdraw it and to adopt any other remedies which may be appropriate.

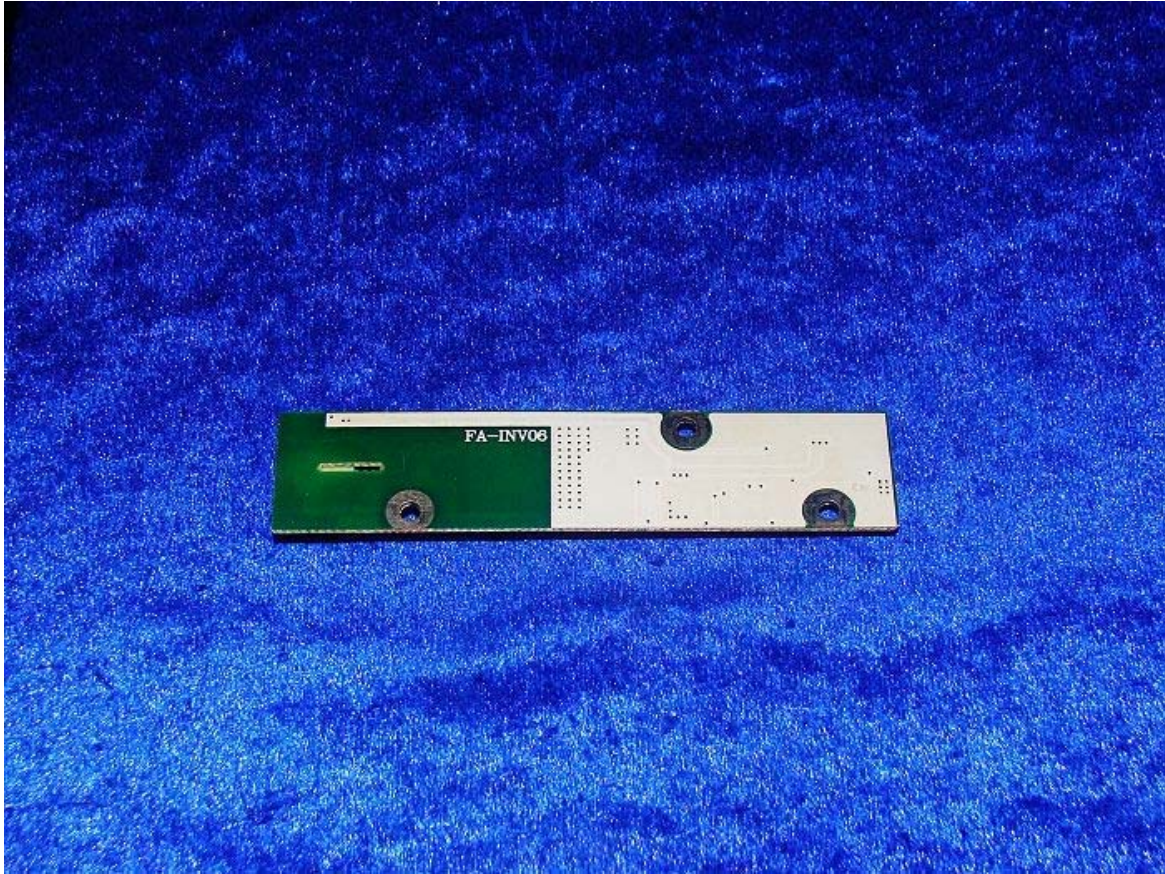

The report refers only to the sample tested and does not apply to the bulk.

This report is issued in confidence to the client and it will be strictly treated as such by the Shenzhen Timeway Technology Consulting Co., Ltd. It may not be reproduced rather in its entirety or in part and it may not be used for advertising. The client to whom the report is issued may, however, show or send it or a certified copy thereof prepared by the Shenzhen Timeway Technology Consulting Co., Ltd to his customer. Supplier or other persons directly concerned. Shenzhen Timeway Technology Consulting Co., Ltd will not, without the consent of the client enter into any discussion of correspondence with any third party concerning the contents of the report.

In the event of the improper use of the report. The Shenzhen Timeway Technology Consulting Co., Ltd reserves the rights to withdraw it and to adopt any other remedies which may be appropriate.



Adaptor and USB Line



-End of the report-

The report refers only to the sample tested and does not apply to the bulk.

This report is issued in confidence to the client and it will be strictly treated as such by the Shenzhen Timeway Technology Consulting Co., Ltd. It may not be reproduced rather in its entirety or in part and it may not be used for advertising. The client to whom the report is issued may, however, show or send it . or a certified copy there of prepared by the Shenzhen Timeway Technology Consulting co., Ltd to his customer. Supplier or others persons directly concerned. Shenzhen Timeway Technology Consulting co., Ltd will not, without the consent of the client enter into any discussion of correspondence with any third party concerning the contents of the report.

In the event of the improper use of the report. The Shenzhen Timeway Technology Consulting co., Ltd reserves the rights to withdraw it and to adopt any other remedies which may be appropriate.