

Over voltage
protect,
Optional

定时开机
RTC_IRQ

开关机按键

u2, u3要加大散热面积!

Winaccord Co.Limited		
Title DPF AML6222D FOR CMO 8DN		
Size B	Document Number POWER	Rev 1.1
Date: Tuesday, July 07, 2009	Sheet 1	of 8

Can change to Core_3.3V or SDRAM_3.3V for Layout convenience

Power On Configuration:

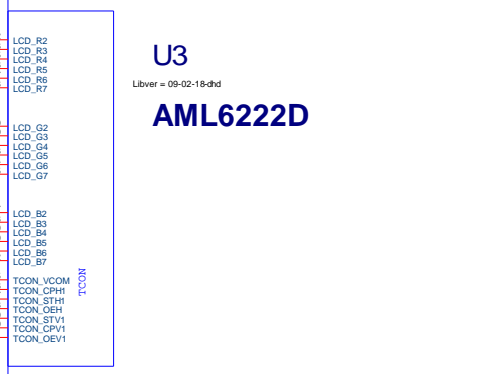
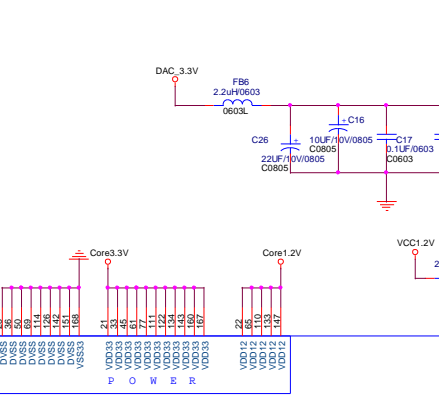
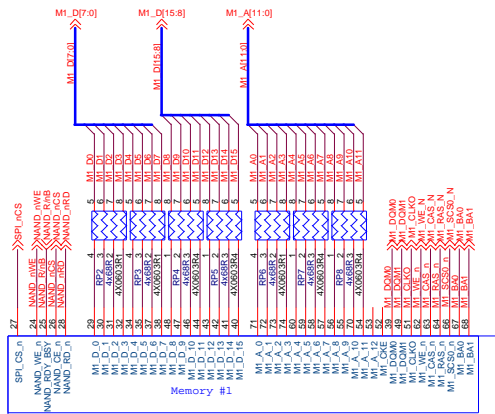
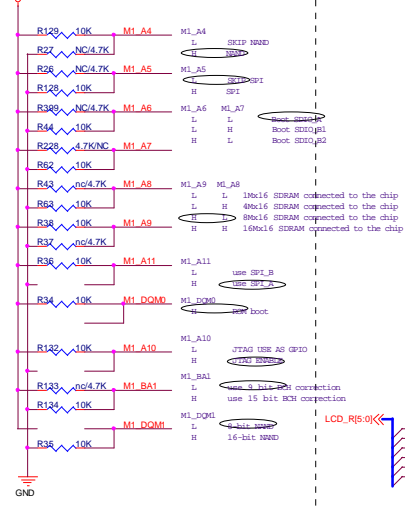

U3
Libver = 09-02-18-dhd
AML6222D

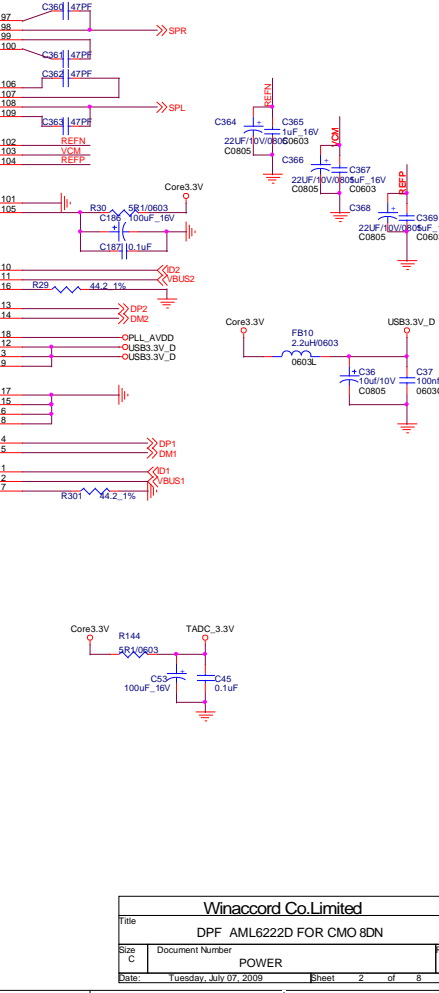
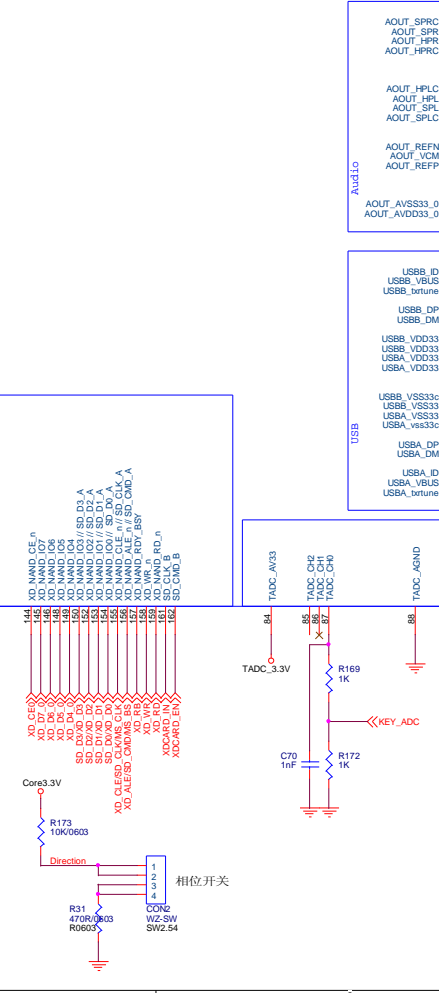
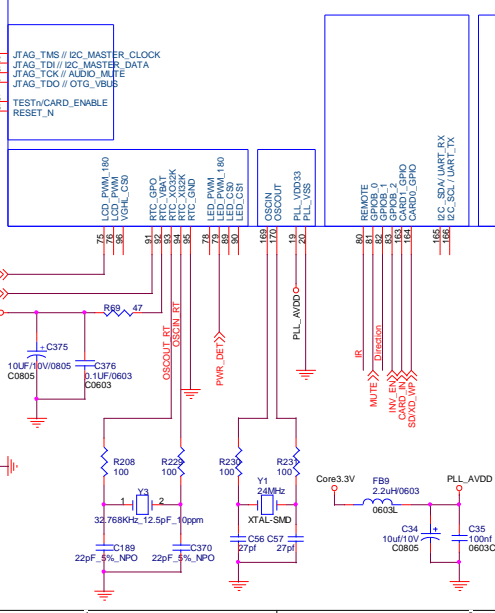
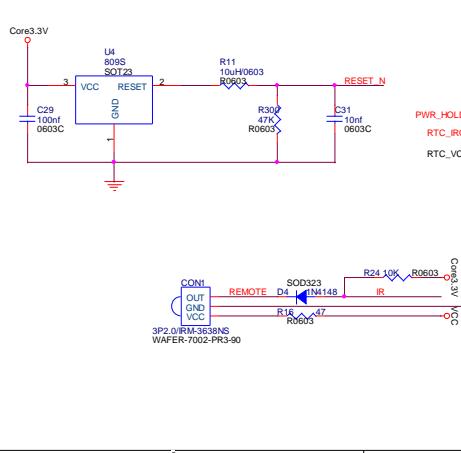
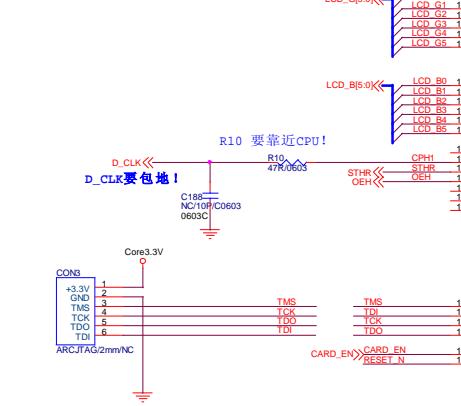

Winacord Co.Limited		
DPF AML6222D FOR CMO 8DN		
File	Document Number	Rev
C	POWER	1.1
Date:	Tuesday, July 07, 2009	Sheet 2 of 8

1 3
9 14
27
37 43 49

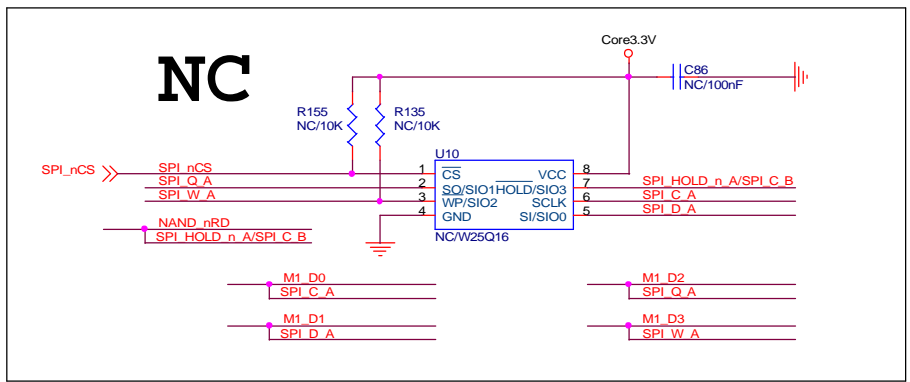
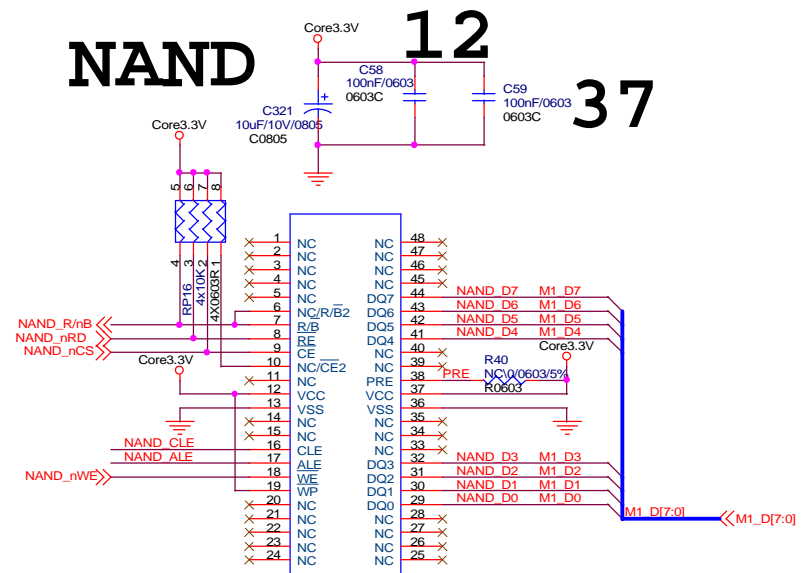
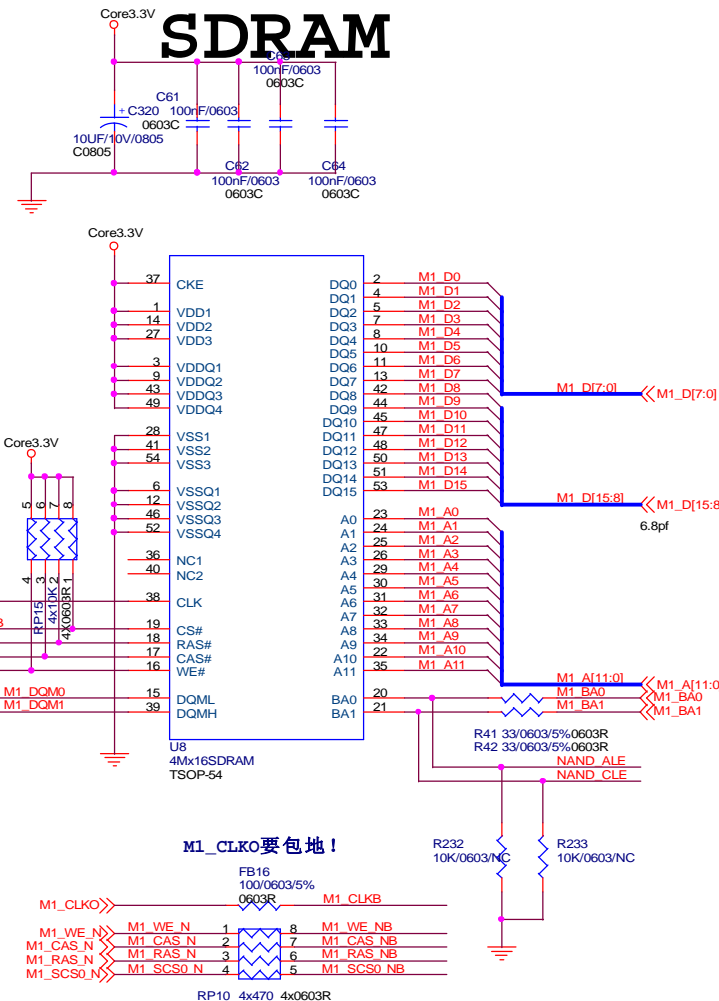

M1_CLKO要包地!

Winaccord Co.Limited		
Title DPF AML6222D FOR CMO 8DN		
Size B	Document Number POWER	Rev 1.1
Date: Tuesday, July 07, 2009	Sheet 3	of 8

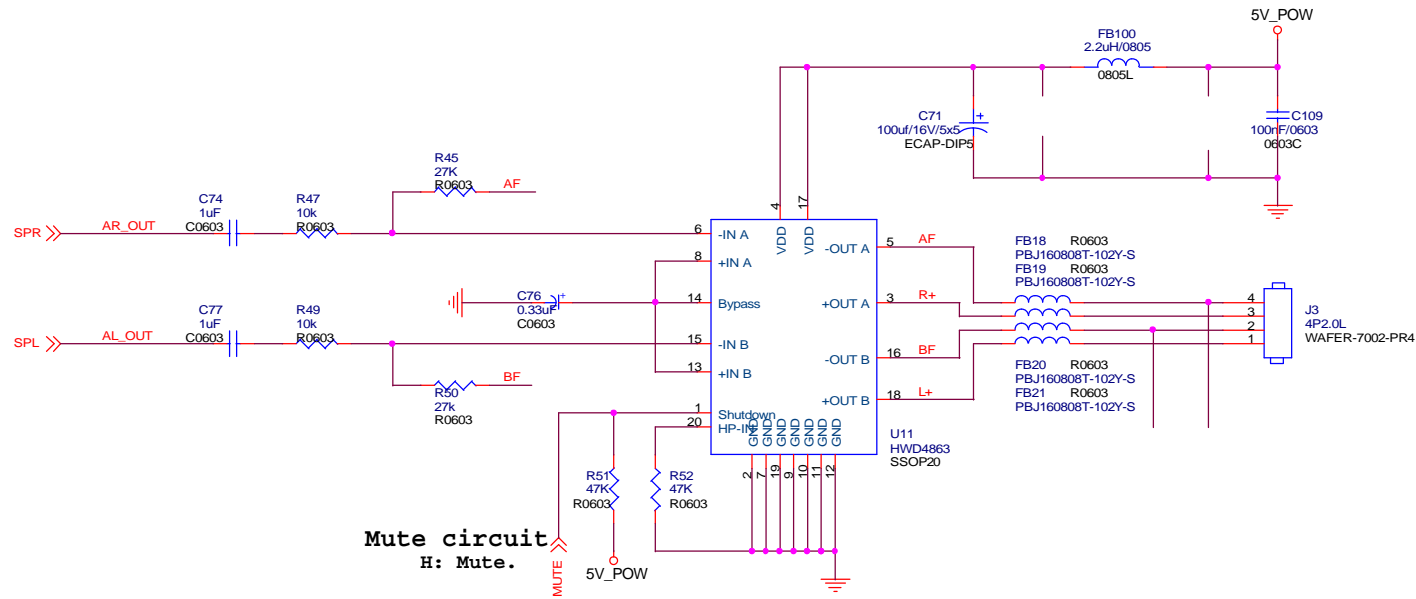

Winaccord Co.Limited		
Title		
DPF AML6222D FOR CMO 8DN		
Size	Document Number	Rev
B	POWER	1.1
Date:	Tuesday, July 07, 2009	Sheet 4 of 8

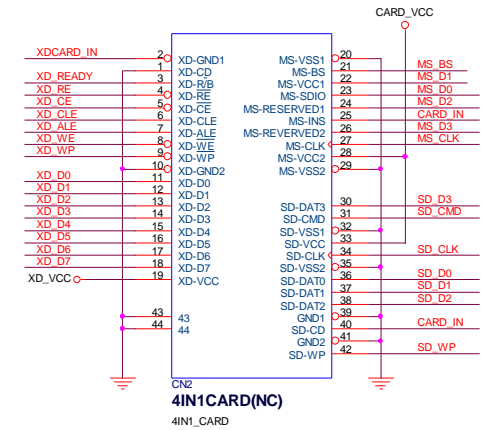
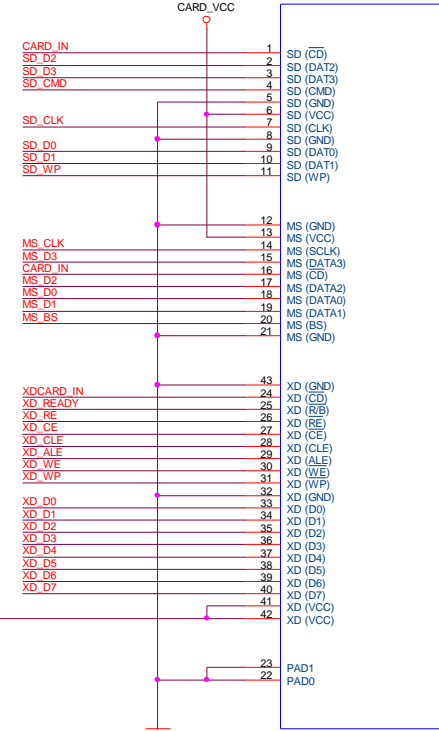
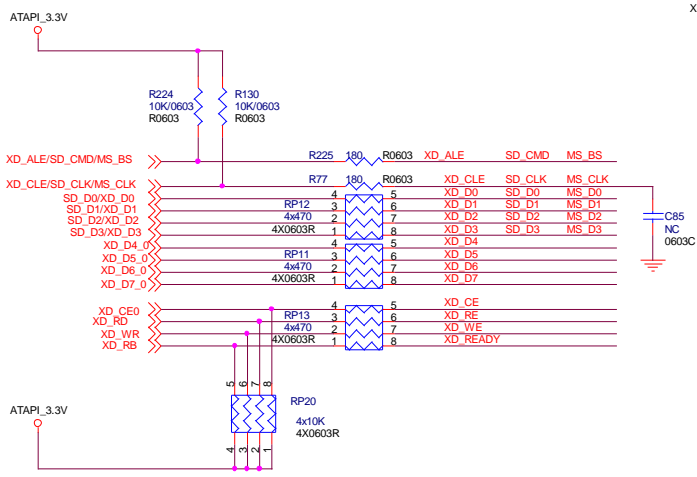
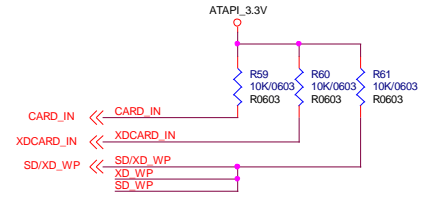
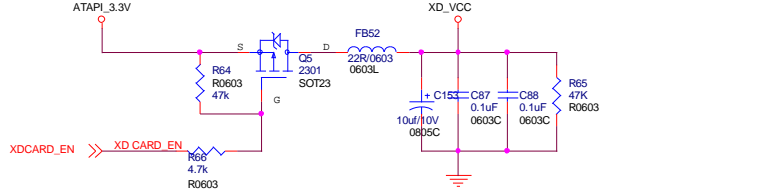
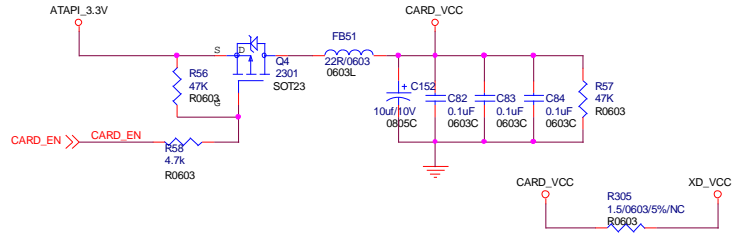

Winaccord Co.Limited		
Title DPF AML6222D FOR CMO 8DN		
Size Custom	Document Number POWER	Rev 1.1
Date: Tuesday, July 07, 2009	Sheet 5	of 8

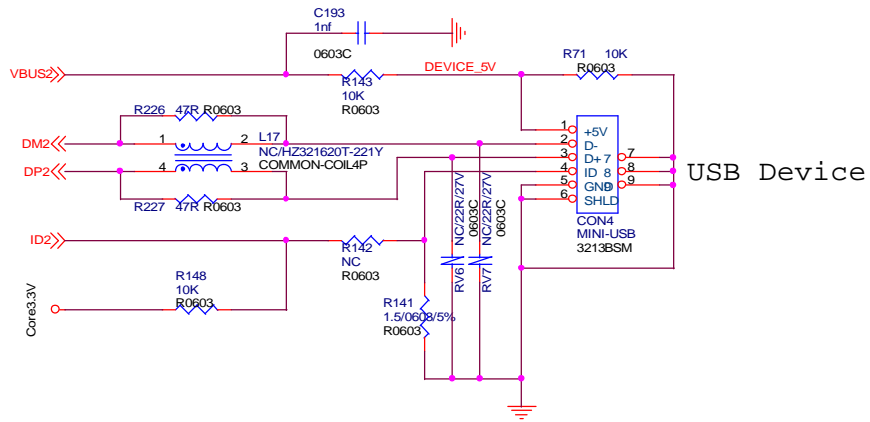
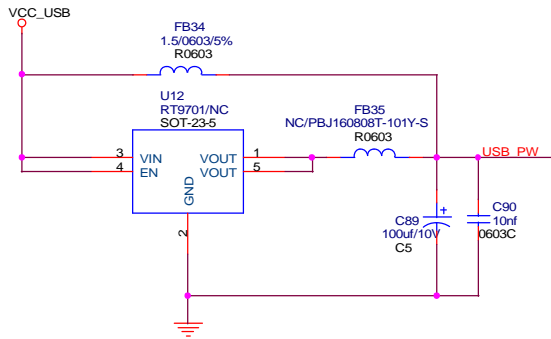
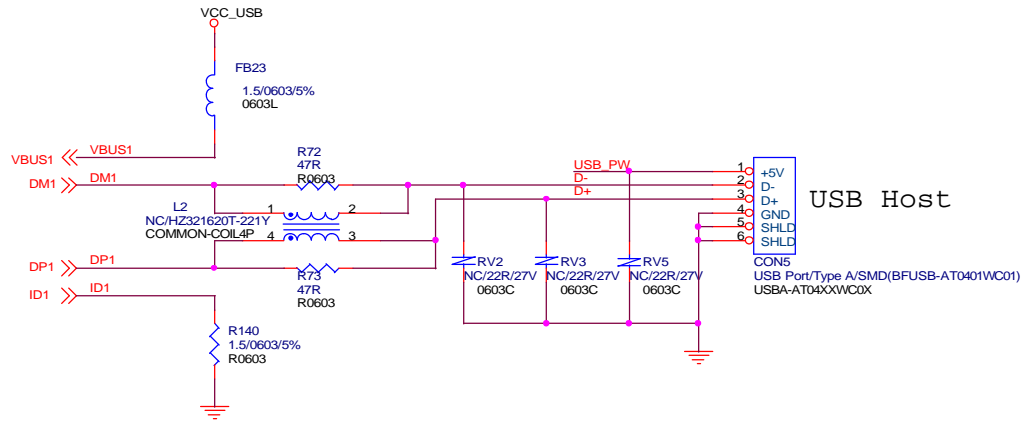
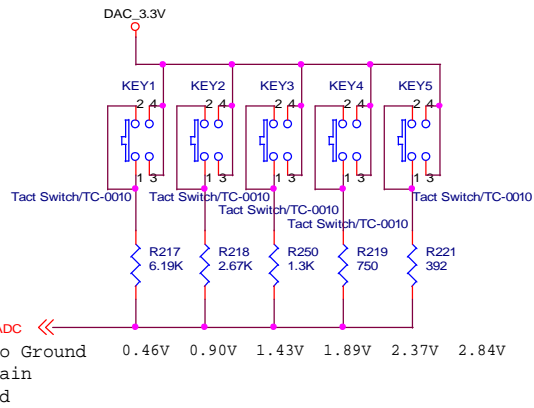

Winaccord Co.Limited			
Title			
DPF AML6222D FOR CMO 8DN			
Size B	Document Number	POWER	Rev 1.1
Date:	Tuesday, July 07, 2009	Sheet 6 of 8	

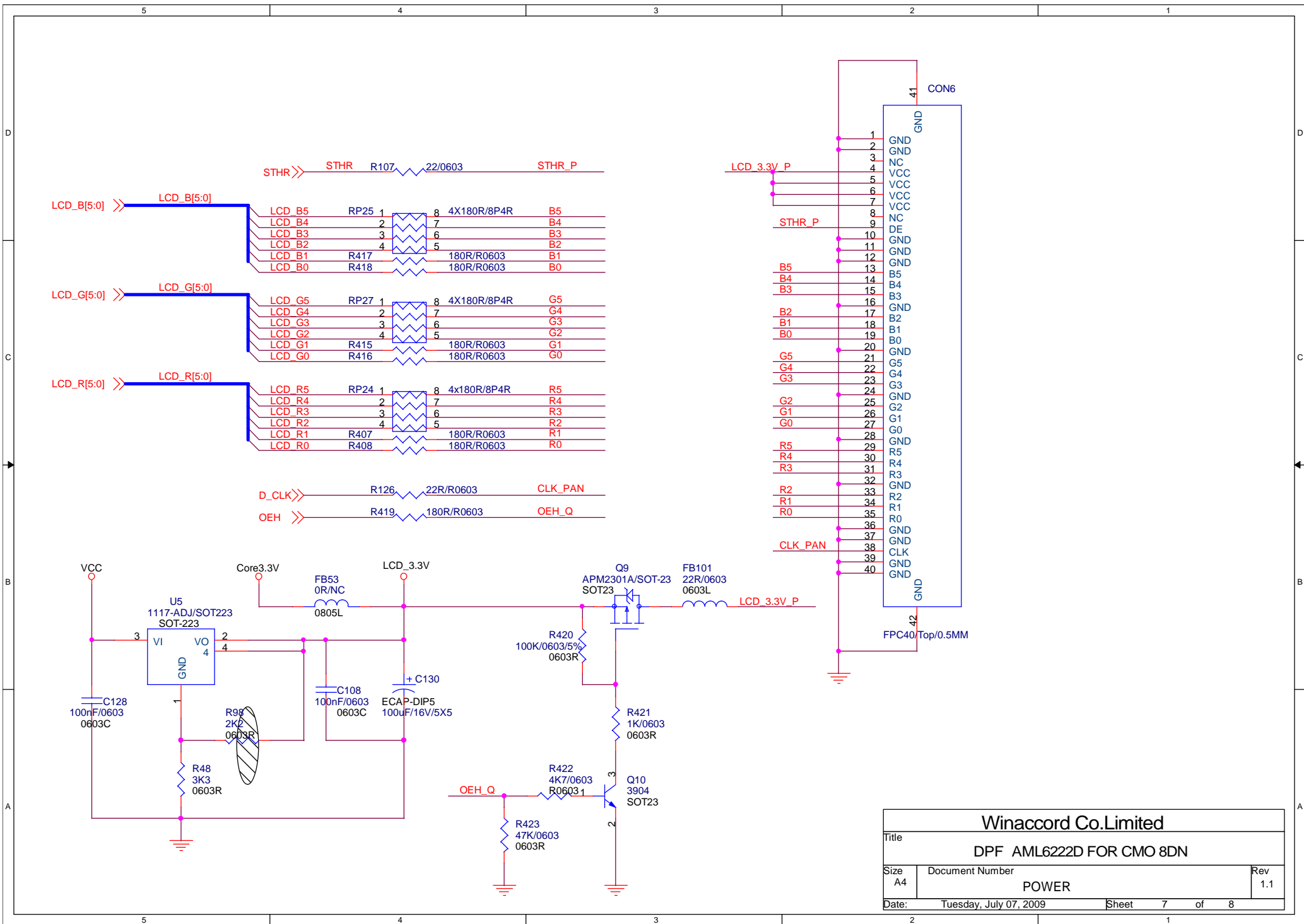

Winaccord Co.Limited		
Title DPF AML6222D FOR CMO 8DN		
Size A4	Document Number POWER	Rev 1.1
Date: Tuesday, July 07, 2009	Sheet 7	of 8

LED_BL

LED_BL_1

C107
220uF/16V/8X5
ECAP-DIP8

C201
100nF/0603
0603C

R122
4K7/0603/5%
R0603

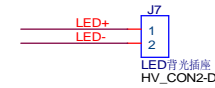
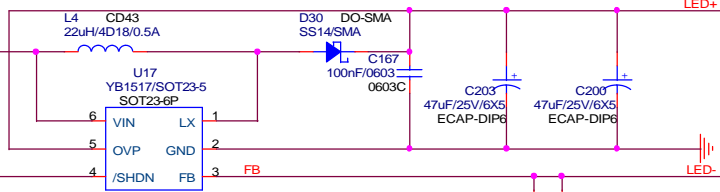

Winaccord Co.Limited			
Title DPF AML6222D FOR CMO 8DN			
Size B	Document Number POWER	Rev 1.1	
Date:	Tuesday, July 07, 2009	Sheet	8 of 8