

FCC TEST REPORT

For

8 inch Digital Photo Frame

MODEL No.: DF08006-14-XXX(X=A-Z, a-z, 0-9)

Trademark: N/A

FCC ID: V37-6222-8DN

REPORT NO: KA09066048E

ISSUE DATE: July 07, 2009

Prepared for

WIN ACCORD LTD.

**12F, NO. 225, SEC 5, 105 SONG SHAN DIST.,
NAN JING EAST ROAD, TAIPEI, TAIWAN**

Prepared by

DONGGUAN EMTEK CO., LTD

**No. 281, Guantai Road, Nancheng District,
Dongguan, Guangdong, China**

TEL: +86-769-22807078

FAX: +86-769-22807079

TABLE OF CONTENTS

1. GENERAL INFORMATION.....	4
1.1 Description of Device (EUT).....	4
1.2. Description of Support Device	6
1.3 Test Facility	7
1.4 Measurement Uncertainty.....	7
2. POWER LINE CONDUCTED MEASUREMENT.....	8
2.1. Test Equipment.....	8
2.2. Block Diagram of Test Setup.....	8
2.3. Power Line Conducted Emission Measurement Limits.....	9
2.4. Configuration of EUT on Measurement	9
2.5. Operating Condition of EUT	9
2.6. Test Procedure	9
2.7. Power Line Conducted Emission Measurement Results	10
3. RADIATED EMISSION MEASUREMENT.....	38
3.1. Test Equipment.....	38
3.2. Block Diagram of Test Setup.....	39
3.3. Radiated Emission Limit	39
3.4. EUT Configuration on Measurement	40
3.5. Operating Condition of EUT	40
3.6. Test Procedure	40
3.7. Radiated Emission Noise Measurement Results.....	40
4. PHOTOGRAPHS	错误！未定义书签。

TEST REPORT DESCRIPTION

Applicant : WIN ACCORD LTD.
Manufacturer : WIN ACCORD LTD.
EUT : 8 inch Digital Photo Frame
FCC ID No. : V37-6222-8DN
Test Voltage : 120V/60Hz
File Number : KA09066048E
Date of Test : July 01, 2009 to July 06, 2009

Measurement Procedure Used:

FCC Rules and Regulations Part 15 Subpart B Class B July 2008 & FCC / ANSI C63.4-2003

The device described above is tested by Dongguan EMTEK Co., Ltd. to determine the maximum emission levels emanating from the device. The maximum emission levels are compared to the FCC Part 15 Subpart Class B limits both radiated and conducted emissions. The measurement results are contained in this test report and Dongguan EMTEK Co., Ltd. is assumed full responsibility for the accuracy and completeness of these measurements. Also, this report shows that the Equipment Under Test (EUT) is to be technically compliant with the FCC requirements.

This report applies to above tested sample only. This report shall not be reproduced in part without written approval of Dongguan EMTEK Co., Ltd.

Approved By



Nicol Lee / Q.A. Manager
DONGGUAN EMTEK CO., LTD.

1. GENERAL INFORMATION

1.1. Description of Device (EUT)

EUT : 8 inch Digital Photo Frame

Model Number : Basic Model: DF08006-14-XXX, (X=A-Z, a-z, 0-9)
Additional Model: DMF080W43, DF-F8S, BS08N.

(Note: Those models are the same except appearance and model names, all models use the same FCC ID Number.)

Cable : USB Line, 1.5m shielded line, with a core.

FCC ID Number : V37-6222-8DN

Trade Mark : N/A

Power Supply : 100~240V 50/60Hz

ADAPTER 1 : Manufacturer: HONOR ELECTRONIC CO., LTD.
M/N: ADS-12G-0605010GPCU
Input: AC 100~240V 50/60Hz
Output: DC 5V 2.0A
Output line: Unshielded line (with a core)

ADAPTER 2 : Manufacturer: E-TEK Electronics Manufactory Ltd.
M/N: ZDA050200US
Input: AC 100~240V 50/60Hz
Output: DC 5V 2.0A
Output line: Unshielded line (with a core)

ADAPTER 3 : Manufacturer: MOSO
M/N: XKD-C2000IC5.0-12W
Input: AC 100~240V 50/60Hz
Output: DC 5V 2.0A
Output line: Unshielded line (with a core)

Remark : They are different model name and appearance.

Applicant : WIN ACCORD LTD.

Address : 12F, NO. 225, SEC 5, 105 SONG SHAN DIST., NAN JING
EAST ROAD, TAIPEI, TAIWAN

Manufacturer : WIN ACCORD LTD.

Address : 12F, NO. 225, SEC 5, 105 SONG SHAN DIST., NAN JING
EAST ROAD, TAIPEI, TAIWAN

Date of sample : July 01, 2009

Date of Test : July 01, 2009 to July 06, 2009

1.2. Description of Support Device

PC	: Manufacturer: Dell Inc. M/N: DCSM S/N: CXBMMZX FCC ID: DoC
LCD Monitor	: Manufacturer: Dell Inc. M/N: E1909Wf FCC ID: DoC
USB Mouse	: Manufacturer: Dell Inc. M/N: M-UAK DEL7 P/N: XN966 FCC ID: DoC
USB Keyboard	: Manufacturer: Dell Inc. M/N: L30U S/N:D1C FCC ID: DoC
Printer	: Manufacturer: HP M/N:HP LaserJet 1020 S/N: CNCK512065 P/N: Q5911A FCC ID: DoC
USB	: Kingston 2GB
SD Card	: Kingston 2GB

1.3 Test Facility

Site Description

EMC Lab. : Accredited by CNAS, 2007.07.27
The certificate is valid until 2012.07.26
The Laboratory has been assessed and proved to be in compliance with CNAS/CL01:2005
The Certificate Registration Number is L3150

Accredited by TUV Rheinland Shenzhen 2008.5
The certificate is valid until 2009.12
The Laboratory has been assessed according to the requirements ISO/IEC 17025

Accredited by FCC, Nov. 05, 2008
The Certificate Number is 247565.

Accredited by Industry Canada, May 24, 2008
The Certificate Registration Number. is 46405-4480

Name of Firm : Dongguan EMTEK Co., Ltd.
Site Location : No.281, Guantai Road, Nancheng District, Dongguan, Guangdong, China.

1.4 Measurement Uncertainty

Conducted Emission Uncertainty : $U_r = 3.3$

Radiated Emission Uncertainty : $U_c = 2.8$

Disturbance Power Uncertainty : $U_c = 2.6$

2. POWER LINE CONDUCTED MEASUREMENT

2.1. Test Equipment

The following test equipments are used during the power line conducted measurement:

Item	Equipment	Manufacturer	Model No.	Serial No.	Last Cal.	Cal. Interval
1	EMI Test Receiver	ROHDE&SCHWARZ	ESCS30	828985/018	May 29, 2009	1 Year
2	LISN	ROHDE&SCHWARZ	ENV216	100017	May 29, 2009	1Year
3	Conical Housing	EMTEK	N/A	N/A	May 29, 2009	N/A
4	Voltage Probe	SCHWARZBECK	EZ-17	100213	May 29, 2008	1Year
5	50 Ω Coaxial Switch	ANRITSU CORP	MP59B	6100175589	May 29, 2009	1Year

2.2. Block Diagram of Test Setup

2.2.1 Block diagram of connection between the EUT and simulators

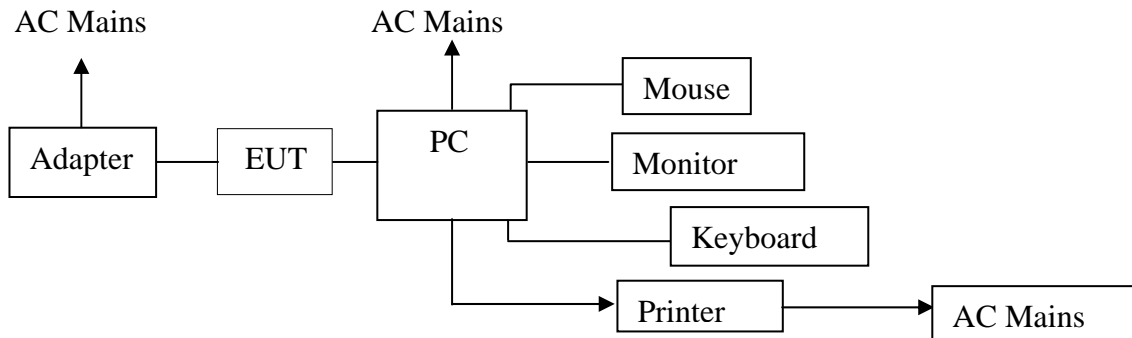

(EUT: 8 inch Digital Photo Frame)

2.2.2 Block diagram of test setup

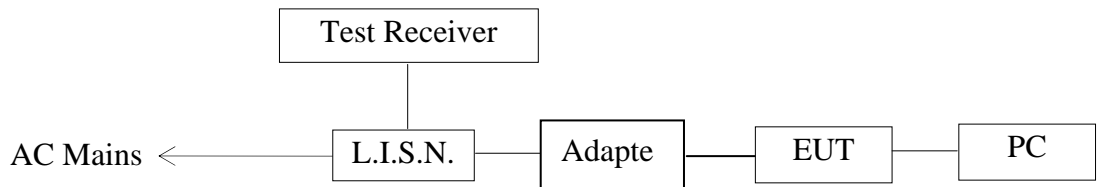

(EUT: 8 inch Digital Photo Frame)

2.3. Power Line Conducted Emission Measurement Limits

Conducted Emission Limits is as following.

Frequency MHz	Limits dB(μ V)	
	Quasi-peak Level	Average Level
0.15 ~ 0.50	66 ~ 56*	56 ~ 46*
0.50 ~ 5.00	56	46
5.00 ~ 30.00	60	50

- Notes: 1. *Decreasing linearly with logarithm of frequency.
2. The lower limit shall apply at the transition frequencies.

2.4. Configuration of EUT on Measurement

The following equipments are installed on Power Line Conducted Emission Measurement to meet the commission requirement and operating regulations in a manner which tends to maximize its emission characteristics in a normal application.

EUT : 8 inch Digital Photo Frame
Model Number : DF-F8S
Manufacturer : WIN ACCORD LTD.

2.5. Operating Condition of EUT

2.5.1. Setup the EUT and simulator as shown as Section 2.2.

2.5.2. Turn on the power of all equipment.

2.5.3. Let the EUT work in test model (Memorying, SD Card Playing, USB Playing, Connect to PC) and measure it.

2.6. Test Procedure

The EUT system is connected to the power mains through a line impedance stabilization network (L.I.S.N.). This provides a 50ohm coupling impedance for the EUT system. Please refer the block diagram of the test setup and photographs. Both sides of AC line are checked to find out the maximum conducted emission. In order to find the maximum emission levels, the relative positions of equipment and all of the interface cables shall be changed according to FCC ANSI C63.4-2003 on Conducted Emission Measurement.

The bandwidth of test receiver (R&S ESCS30) is set at 9KHz.
The frequency range from 150KHz to 30MHz is checked.

2.7. Power Line Conducted Emission Measurement Results

PASS

The frequency range from 150KHz to 30 MHz is investigated.

The scanning waveforms refer to the following pages.

Adapter ADS-12G-0605010GPCU used for test.

Conducted Emission Measurement

File :DF-F8S
 80.0 dBuV

Data :#7

Date: 2009-7-3

Time: 21:13:23

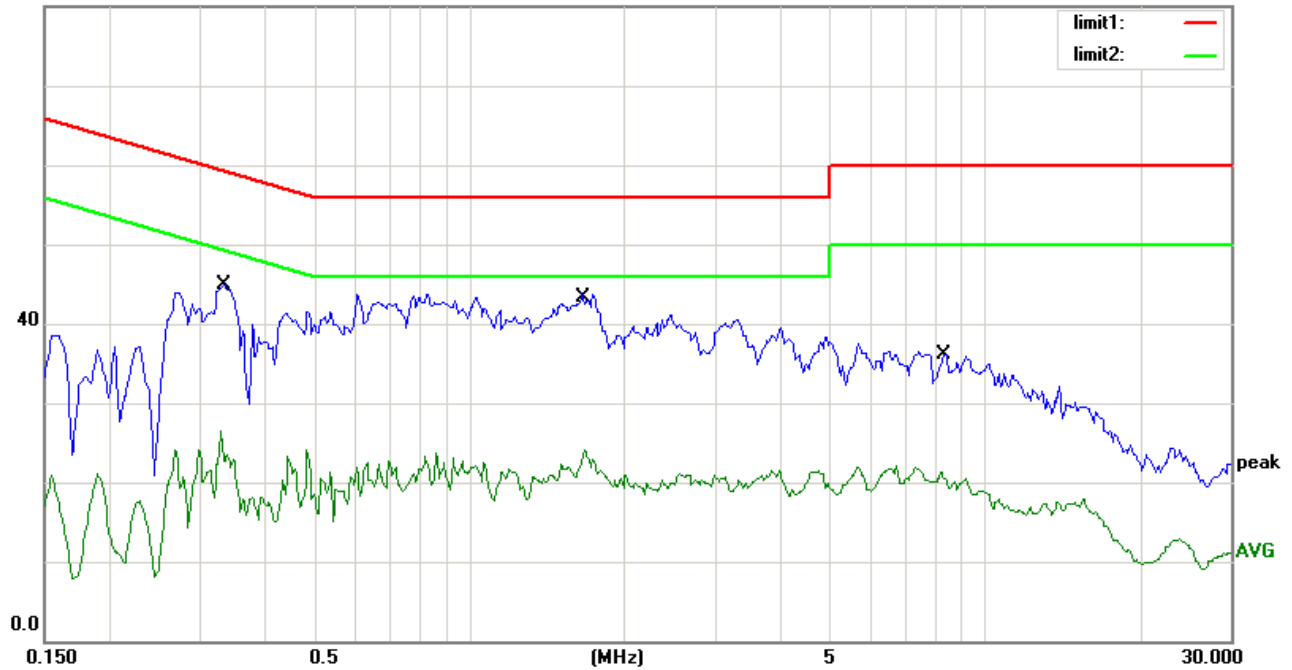

Site site #1

Phase: **N**

Temperature: 25

Limit: (CE)FCC PART 15 class B_QP

Power: AC 120V/60Hz

Humidity: 50 %

EUT: 8 INCH DIGITAL PHOTO FRAME

M/N: DF-F8S

Mode: USB PLAYING

Note: ADS-12G-0605010GPCU

No.	Mk.	Freq. MHz	Reading Level dBuV	Correct Factor dB	Measure- ment dBuV	Limit dBuV	Over dB	Detector	Comment
1	*	0.3300	42.60	0.00	42.60	59.45	-16.85	QP	
2		0.3300	26.90	0.00	26.90	49.45	-22.55	AVG	
3		1.6750	37.40	0.00	37.40	56.00	-18.60	QP	
4		1.6750	21.50	0.00	21.50	46.00	-24.50	AVG	
5		8.2200	29.20	0.00	29.20	60.00	-30.80	QP	
6		8.2200	20.00	0.00	20.00	50.00	-30.00	AVG	

*:Maximum data x:Over limit !:over margin Comment: Factor build in receiver. Operator:

Conducted Emission Measurement

File :DF-F8S
 80.0 dBuV

Data :#8

Date: 2009-7-3

Time: 21:17:40

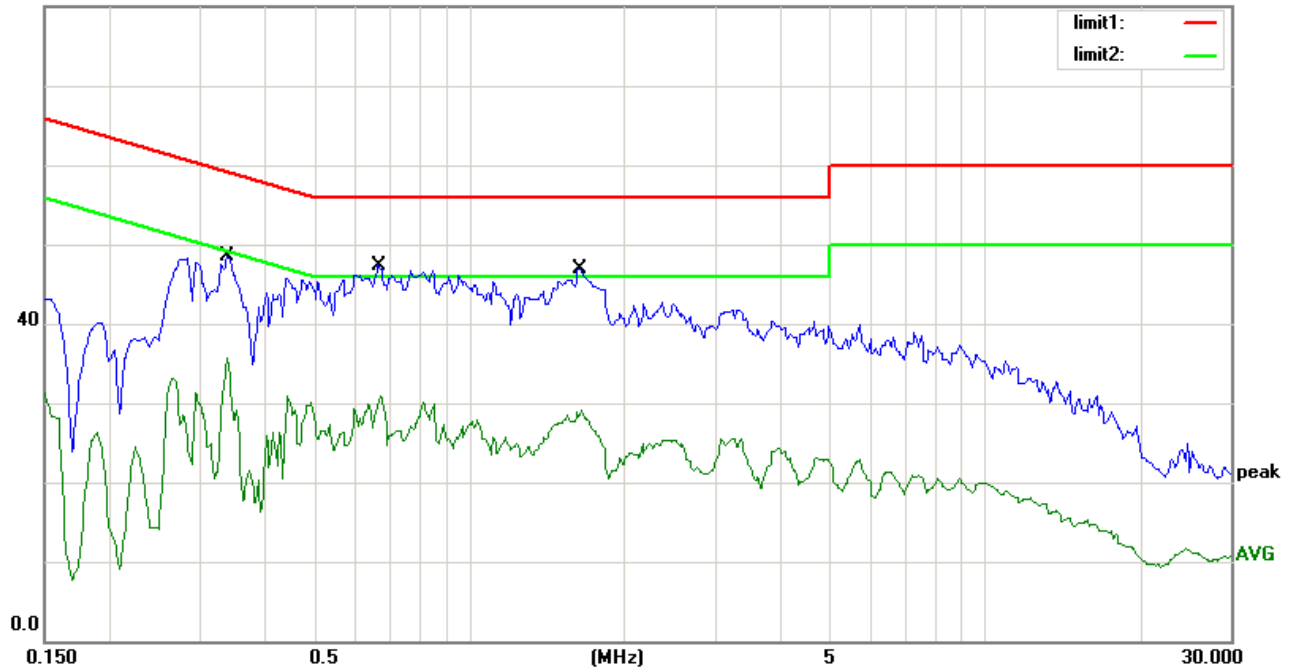

Site site #1

Phase: **L1**

Temperature: 25

Limit: (CE)FCC PART 15 class B_QP

Power: AC 120V/60Hz

Humidity: 50 %

EUT: 8 INCH DIGITAL PHOTO FRAME

M/N: DF-F8S

Mode: USB PLAYING

Note: ADS-12G-0605010GPCU

No.	Mk.	Freq. MHz	Reading Level dBuV	Correct Factor dB	Measure- ment dBuV	Limit dBuV	Over dB	Detector	Comment
1		0.3400	45.50	0.00	45.50	59.20	-13.70	QP	
2		0.3400	35.67	0.00	35.67	49.20	-13.53	AVG	
3	*	0.6750	42.60	0.00	42.60	56.00	-13.40	QP	
4		0.6750	30.85	0.00	30.85	46.00	-15.15	AVG	
5		1.6500	39.80	0.00	39.80	56.00	-16.20	QP	
6		1.6500	29.06	0.00	29.06	46.00	-16.94	AVG	

*:Maximum data x:Over limit !:over margin Comment: Factor build in receiver. Operator:

Conducted Emission Measurement

File :DF-F8S
 80.0 dBuV

Data :#9

Date: 2009-7-3

Time: 21:22:54

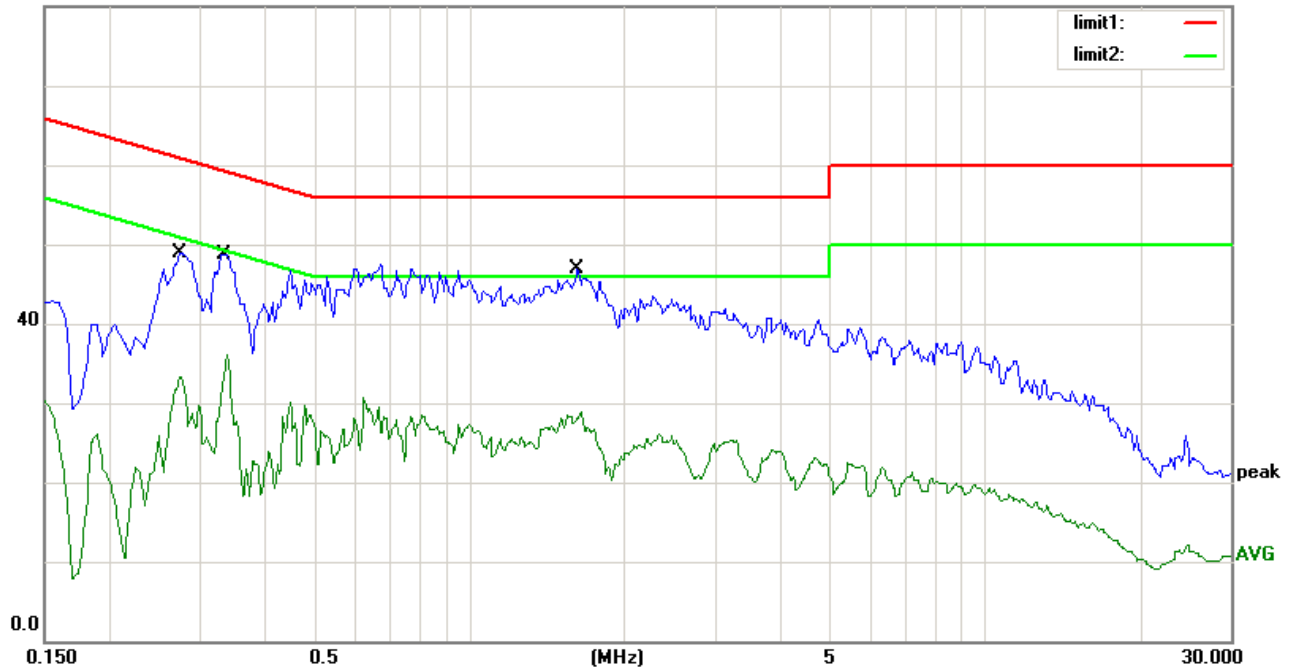

Site site #1

Phase: **L1**

Temperature: 25

Limit: (CE)FCC PART 15 class B_QP

Power: AC 120V/60Hz

Humidity: 50 %

EUT: 8 INCH DIGITAL PHOTO FRAME

M/N: DF-F8S

Mode: SD CARD PLAYING

Note: ADS-12G-0605010GPCU

No.	Mk.	Freq. MHz	Reading Level dBuV	Correct Factor dB	Measure- ment dBuV	Limit dBuV	Over dB	Detector	Comment
1		0.2750	46.00	0.00	46.00	60.97	-14.97	QP	
2		0.2750	31.20	0.00	31.20	50.97	-19.77	AVG	
3	*	0.3350	45.90	0.00	45.90	59.33	-13.43	QP	
4		0.3350	35.00	0.00	35.00	49.33	-14.33	AVG	
5		1.6250	39.90	0.00	39.90	56.00	-16.10	QP	
6		1.6250	27.00	0.00	27.00	46.00	-19.00	AVG	

*:Maximum data x:Over limit !:over margin Comment: Factor build in receiver. Operator:

Conducted Emission Measurement

File :DF-F8S
 80.0 dBuV

Data :#10

Date: 2009-7-3

Time: 21:28:55

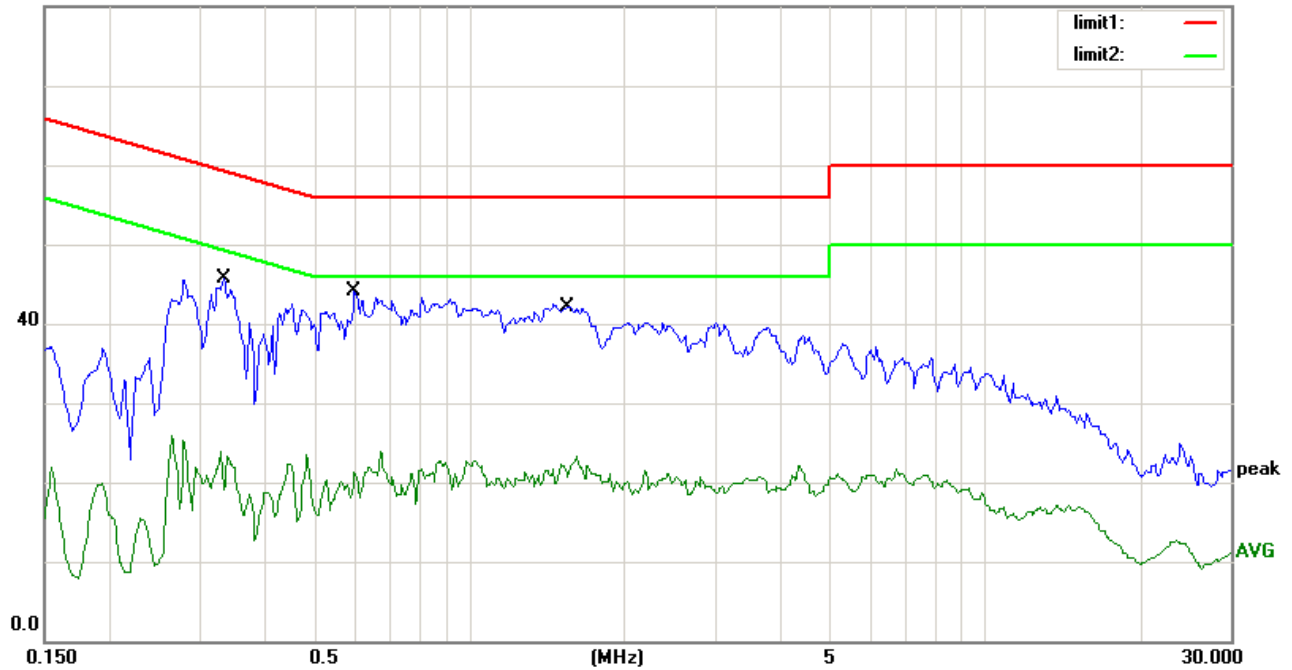

Site site #1

Phase: **N**

Temperature: 25

Limit: (CE)FCC PART 15 class B_QP

Power: AC 120V/60Hz

Humidity: 50 %

EUT: 8 INCH DIGITAL PHOTO FRAME

M/N: DF-F8S

Mode: SD CARD PLAYING

Note: ADS-12G-0605010GPCU

No.	Mk.	Freq. MHz	Reading Level dBuV	Correct Factor dB	Measure- ment dBuV	Limit dBuV	Over dB	Detector	Comment
1	*	0.3350	43.20	0.00	43.20	59.33	-16.13	QP	
2		0.3350	26.80	0.00	26.80	49.33	-22.53	AVG	
3		0.6000	37.50	0.00	37.50	56.00	-18.50	QP	
4		0.6000	20.60	0.00	20.60	46.00	-25.40	AVG	
5		1.5601	36.70	0.00	36.70	56.00	-19.30	QP	
6		1.5601	21.20	0.00	21.20	46.00	-24.80	AVG	

*:Maximum data x:Over limit !:over margin Comment: Factor build in receiver. Operator:

Conducted Emission Measurement

File :DF-F8S
 80.0 dBuV

Data :#11

Date: 2009/07/03

Time: 21:35:07

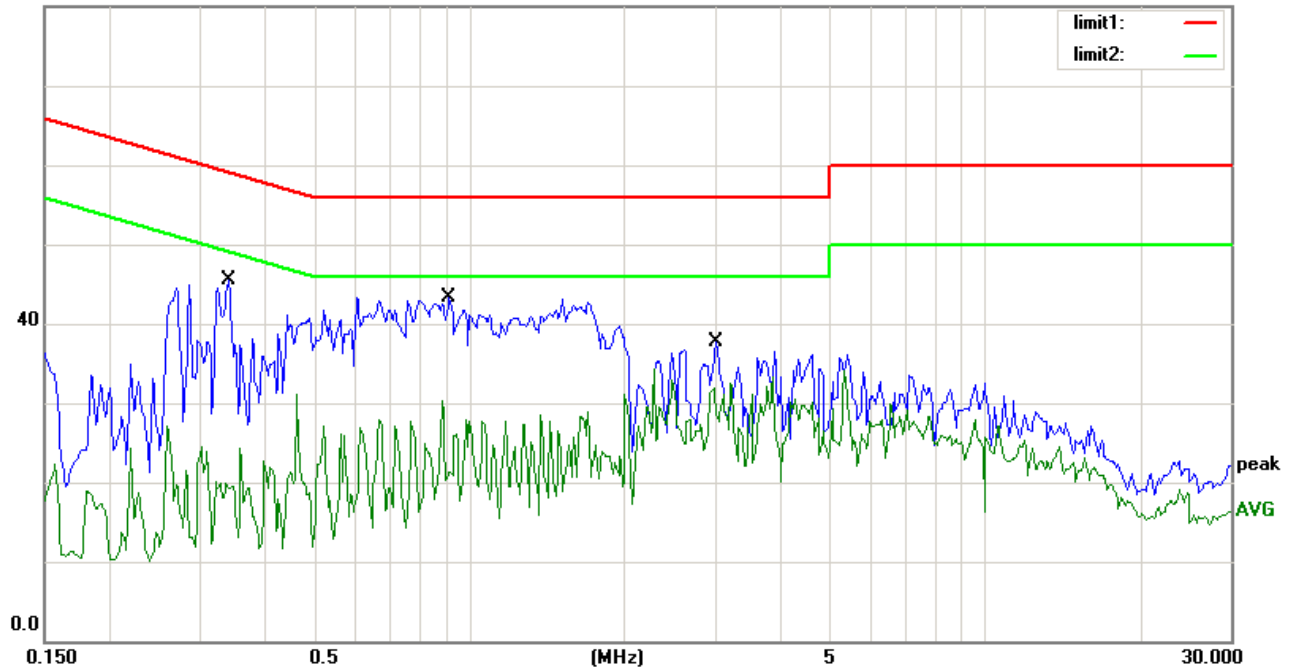

Site site #1

Phase: **L1**

Temperature: 25

Limit: (CE)FCC PART 15 class B_QP

Power: AC 120V/60Hz

Humidity: 50 %

EUT: 8 INCH DIGITAL PHOTO FRAME

M/N: DF-F8S

Mode: Memorying

Note: ADS-12G-0605010GPCU

No.	Mk.	Freq. MHz	Reading Level dBuV	Correct Factor dB	Measure- ment dBuV	Limit dBuV	Over dB	Detector	Comment
1		0.3414	42.10	0.00	42.10	59.17	-17.07	QP	
2		0.3414	25.00	0.00	25.00	49.17	-24.17	AVG	
3		0.9156	37.30	0.00	37.30	56.00	-18.70	QP	
4		0.9156	30.28	0.00	30.28	46.00	-15.72	AVG	
5		3.0156	34.30	0.00	34.30	56.00	-21.70	QP	
6	*	3.0156	32.83	0.00	32.83	46.00	-13.17	AVG	

*:Maximum data x:Over limit !:over margin Comment: Factor build in receiver. Operator:

Conducted Emission Measurement

File :DF-F8S
 80.0 dBuV

Data :#12

Date: 2009/07/03

Time: 21:39:07

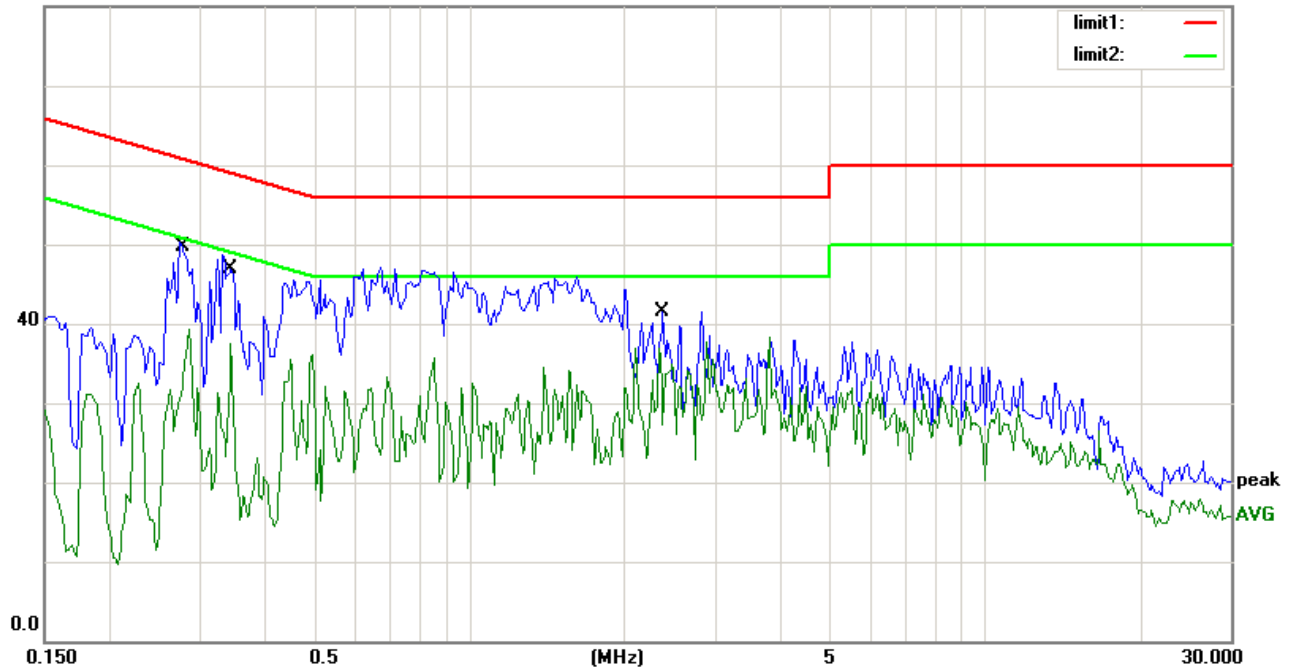

Site site #1

Phase: **N**

Temperature: 25

Limit: (CE)FCC PART 15 class B_QP

Power: AC 120V/60Hz

Humidity: 50 %

EUT: 8 INCH DIGITAL PHOTO FRAME

M/N: DF-F8S

Mode: Memorying

Note: ADS-12G-0605010GPCU

No.	Mk.	Freq. MHz	Reading Level dBuV	Correct Factor dB	Measure- ment dBuV	Limit dBuV	Over dB	Detector	Comment
1		0.2790	46.50	0.00	46.50	60.85	-14.35	QP	
2		0.2790	39.29	0.00	39.29	50.85	-11.56	AVG	
3		0.3453	45.30	0.00	45.30	59.07	-13.77	QP	
4		0.3453	37.45	0.00	37.45	49.07	-11.62	AVG	
5		2.3711	36.90	0.00	36.90	56.00	-19.10	QP	
6	*	2.3711	37.60	0.00	37.60	46.00	-8.40	AVG	

*:Maximum data x:Over limit !:over margin Comment: Factor build in receiver. Operator:

Conducted Emission Measurement

File :DF-F8S
 80.0 dBuV

Data :#27

Date: 2009-7-4

Time: 14:08:29

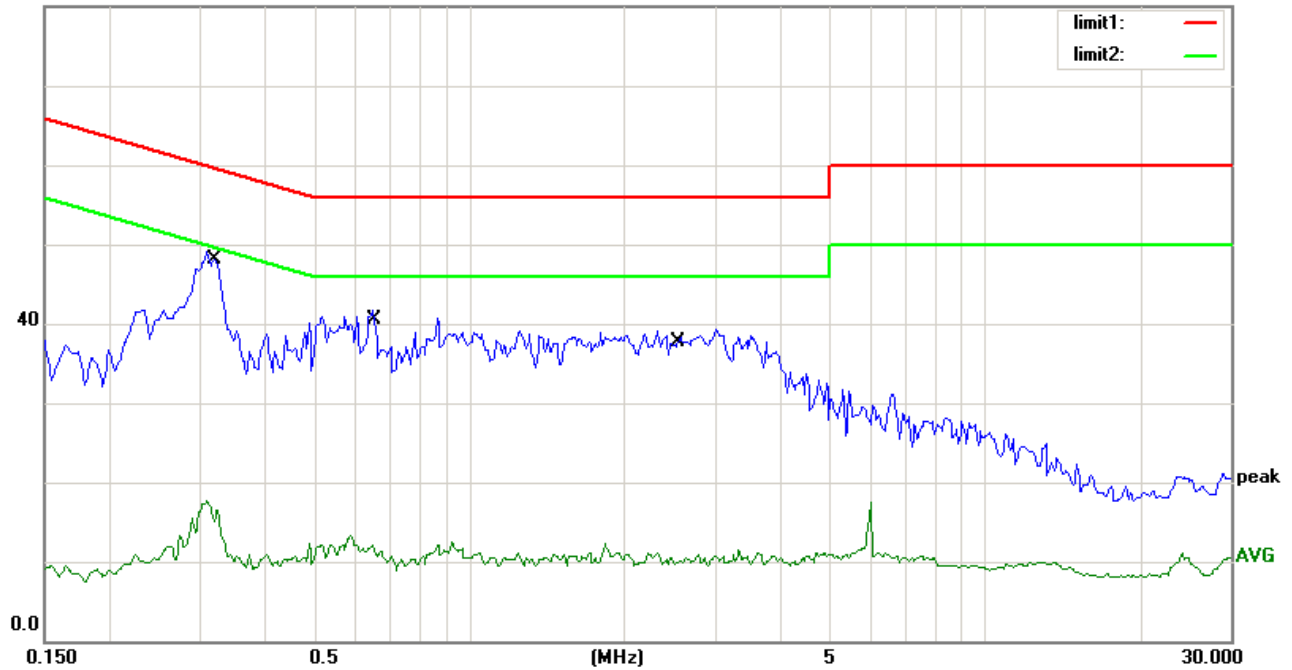

Site site #1

Limit: (CE)FCC PART 15 class B_QP
 EUT: 8 INCH DIGITAL PHOTO FRAME
 M/N: DF-F8S
 Mode: CONNECT TO PC
 Note: ADS-12G-0605010GPCU

Phase: **N**

Power: AC 120V/60Hz

Temperature: 25

Humidity: 50 %

No.	Mk.	Freq. MHz	Reading Level dBuV	Correct Factor dB	Measure- ment dBuV	Limit dBuV	Over dB	Detector	Comment
1	*	0.3183	41.70	0.00	41.70	59.75	-18.05	QP	
2		0.3183	17.70	0.00	17.70	49.75	-32.05	AVG	
3		0.6600	30.40	0.00	30.40	56.00	-25.60	QP	
4		0.6600	10.30	0.00	10.30	46.00	-35.70	AVG	
5		2.5100	28.00	0.00	28.00	56.00	-28.00	QP	
6		2.5100	9.30	0.00	9.30	46.00	-36.70	AVG	

Conducted Emission Measurement

File :DF-F8S
 80.0 dBuV

Data :#28

Date: 2009-7-4

Time: 14:13:05

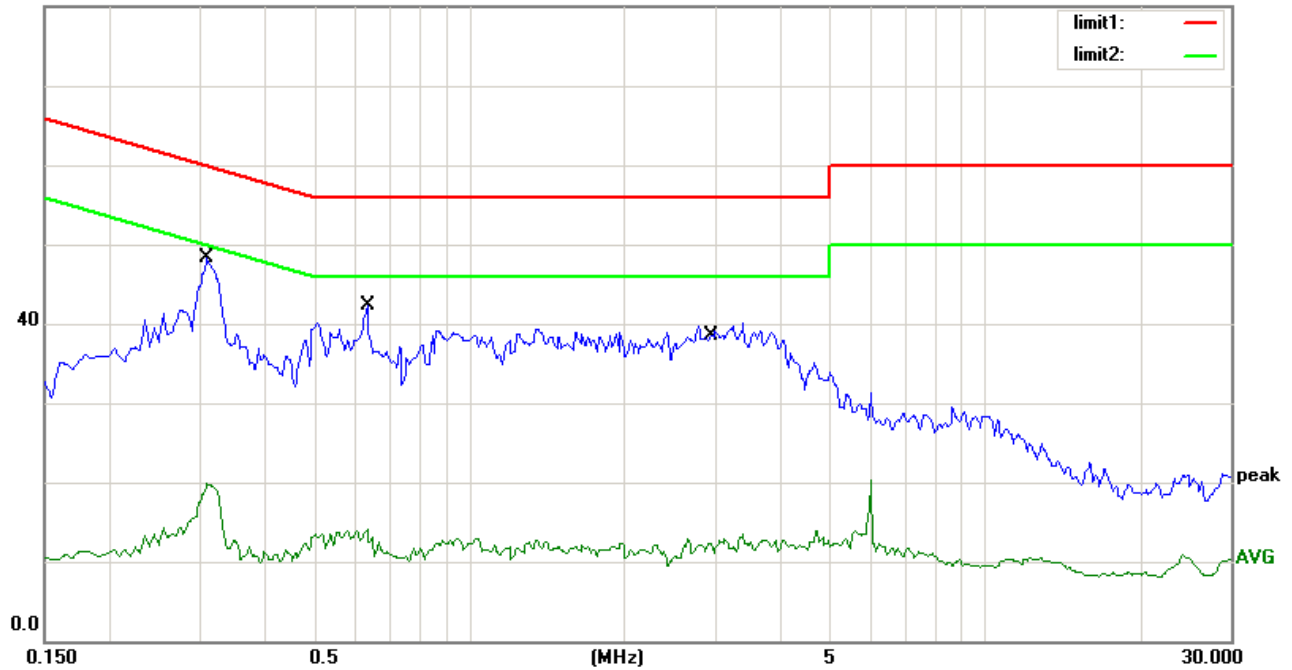

Site site #1

Phase: **L1**

Temperature: 25

Limit: (CE)FCC PART 15 class B_QP

Power: AC 120V/60Hz

Humidity: 50 %

EUT: 8 INCH DIGITAL PHOTO FRAME

M/N: DF-F8S

Mode: CONNECT TO PC

Note: ADS-12G-0605010GPCU

No.	Mk.	Freq. MHz	Reading Level dBuV	Correct Factor dB	Measure- ment dBuV	Limit dBuV	Over dB	Detector	Comment
1	*	0.3116	39.90	0.00	39.90	59.93	-20.03	QP	
2		0.3116	19.70	0.00	19.70	49.93	-30.23	AVG	
3		0.6305	33.90	0.00	33.90	56.00	-22.10	QP	
4		0.6305	13.40	0.00	13.40	46.00	-32.60	AVG	
5		2.9307	30.60	0.00	30.60	56.00	-25.40	QP	
6		2.9307	11.20	0.00	11.20	46.00	-34.80	AVG	

*:Maximum data x:Over limit !:over margin Comment: Factor build in receiver. Operator:

Adapter **ZDA050200US** used for test.

Conducted Emission Measurement

File :DF-F8S
 80.0 dBuV

Data :#13

Date: 2009/07/03

Time: 21:45:34

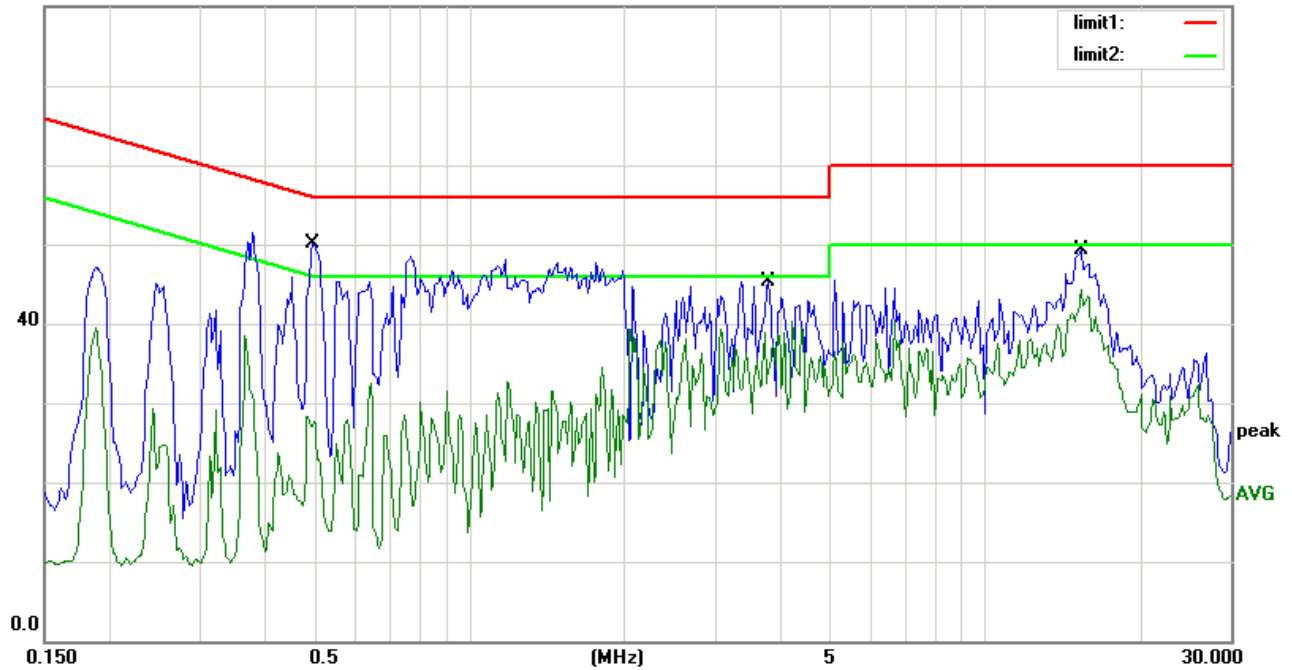

Site site #1

Phase: **N**

Temperature: 25

Limit: (CE)FCC PART 15 class B_QP

Power: AC 120V/60Hz

Humidity: 50 %

EUT: 8 INCH DIGITAL PHOTO FRAME

M/N: DF-F8S

Mode: Memorying

Note: ZDA050200US

No.	Mk.	Freq. MHz	Reading Level dBuV	Correct Factor dB	Measure- ment dBuV	Limit dBuV	Over dB	Detector	Comment
1		0.4977	45.40	0.00	45.40	56.04	-10.64	QP	
2		0.4977	30.20	0.00	30.20	46.04	-15.84	AVG	
3		3.8008	39.00	0.00	39.00	56.00	-17.00	QP	
4		3.8008	38.84	0.00	38.84	46.00	-7.16	AVG	
5		15.4336	43.30	0.00	43.30	60.00	-16.70	QP	
6	*	15.4336	44.23	0.00	44.23	50.00	-5.77	AVG	

*:Maximum data x:Over limit !:over margin Comment: Factor build in receiver. Operator:

Conducted Emission Measurement

File :DF-F8S
 80.0 dBuV

Data :#14

Date: 2009/07/03

Time: 21:50:38

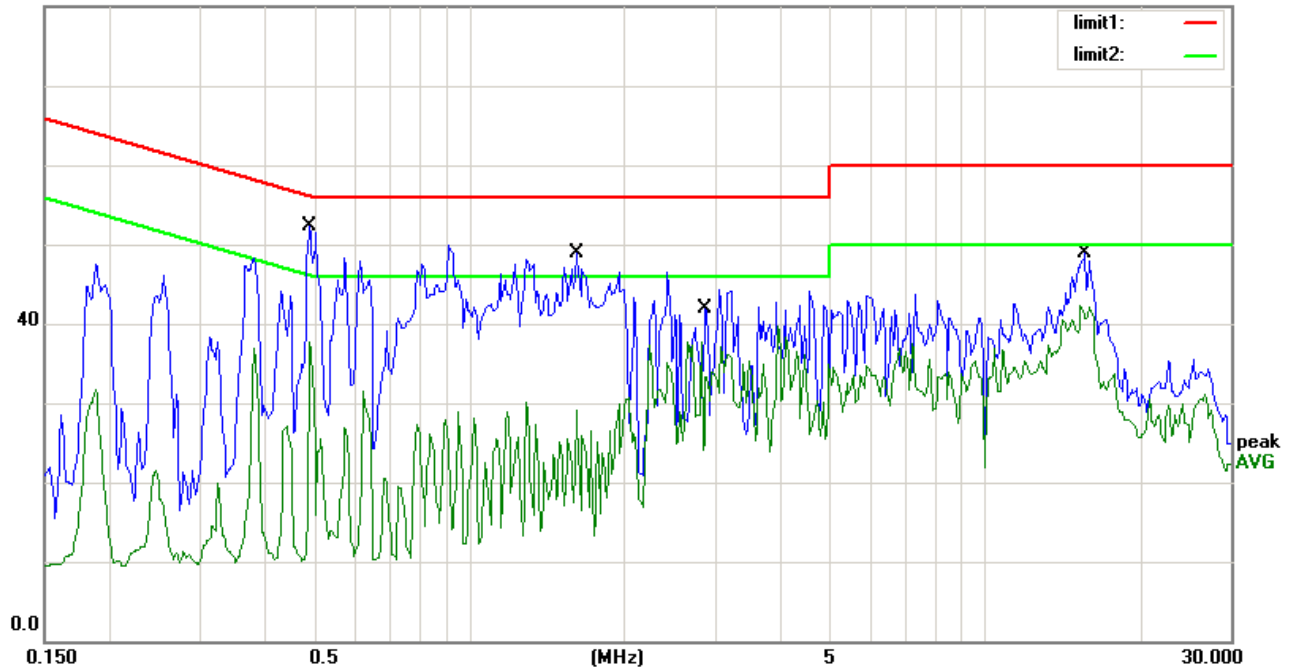

Site site #1

Phase: **L1**

Temperature: 25

Limit: (CE)FCC PART 15 class B_QP

Power: AC 120V/60Hz

Humidity: 50 %

EUT: 8 INCH DIGITAL PHOTO FRAME

M/N: DF-F8S

Mode: Memorying

Note: ZDA050200US

No.	Mk.	Freq. MHz	Reading Level dBuV	Correct Factor dB	Measure- ment dBuV	Limit dBuV	Over dB	Detector	Comment
1		0.4898	46.20	0.00	46.20	56.17	-9.97	QP	
2		0.4898	35.65	0.00	35.65	46.17	-10.52	AVG	
3		1.6148	39.30	0.00	39.30	56.00	-16.70	QP	
4		1.6148	20.70	0.00	20.70	46.00	-25.30	AVG	
5		2.8241	37.40	0.00	37.40	56.00	-18.60	QP	
6	*	2.8241	37.66	0.00	37.66	46.00	-8.34	AVG	
7		15.6484	42.00	0.00	42.00	60.00	-18.00	QP	
8		15.6484	40.70	0.00	40.70	50.00	-9.30	AVG	

*:Maximum data x:Over limit !:over margin Comment: Factor build in receiver. Operator:

Conducted Emission Measurement

File :DF-F8S
 80.0 dBuV

Data :#15

Date: 2009/07/03

Time: 22:00:20

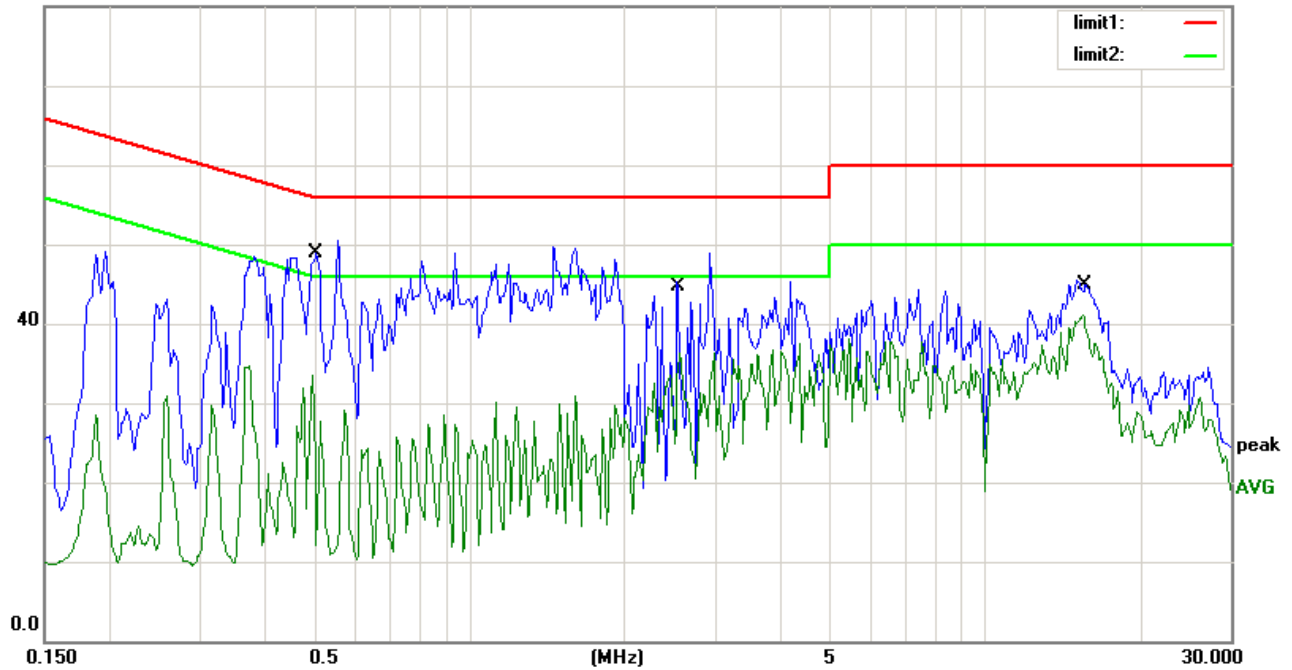

Site site #1

Limit: (CE)FCC PART 15 class B_QP
 EUT: 8 INCH DIGITAL PHOTO FRAME
 M/N: DF-F8S
 Mode: USB PLAYING
 Note: ZDA050200US

Phase: **L1**

Power: AC 120V/60Hz

Temperature: 25

Humidity: 50 %

No.	Mk.	Freq. MHz	Reading Level dBuV	Correct Factor dB	Measure- ment dBuV	Limit dBuV	Over dB	Detector	Comment
1		0.4977	40.40	0.00	40.40	56.04	-15.64	QP	
2		0.4977	33.58	0.00	33.58	46.04	-12.46	AVG	
3		2.5586	37.89	0.00	37.89	56.00	-18.11	QP	
4		2.5586	36.28	0.00	36.28	46.00	-9.72	AVG	
5		15.5273	41.50	0.00	41.50	60.00	-18.50	QP	
6	*	15.5273	41.18	0.00	41.18	50.00	-8.82	AVG	

*:Maximum data x:Over limit !:over margin Comment: Factor build in receiver. Operator:

Conducted Emission Measurement

File :DF-F8S
 80.0 dBuV

Data :#16

Date: 2009/07/03

Time: 22:08:27

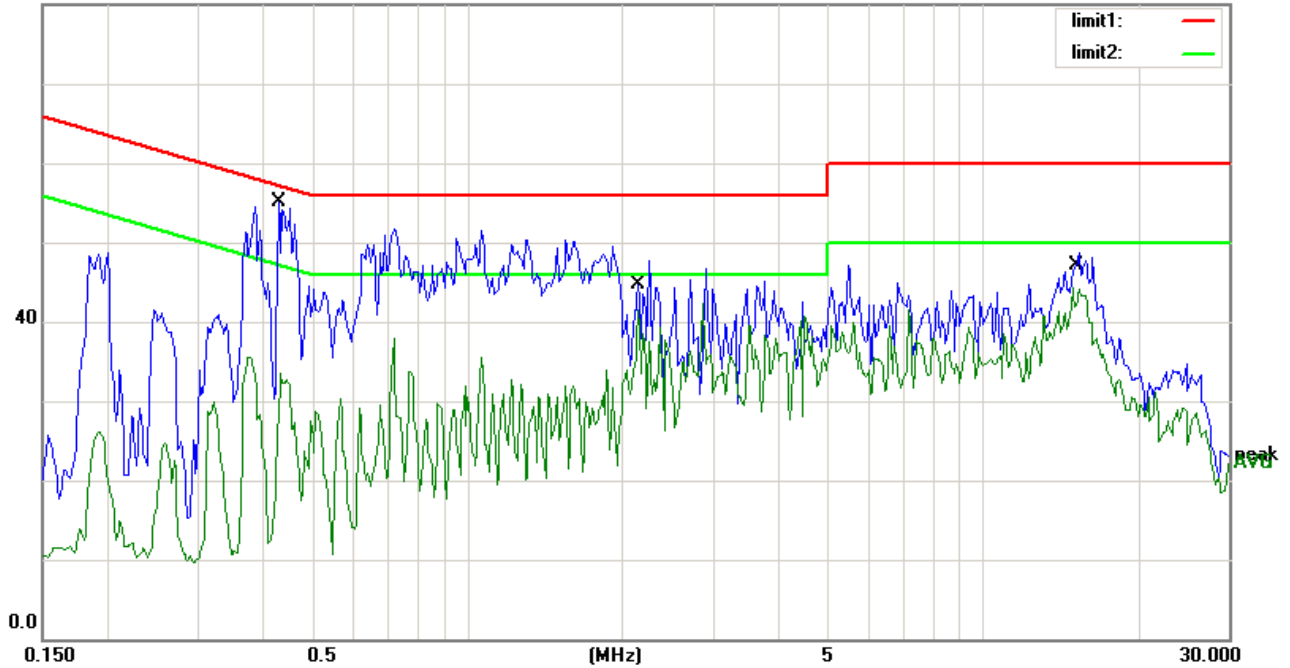

Site site #1

Phase: **N**

Temperature: 25

Limit: (CE)FCC PART 15 class B_QP

Power: AC 120V/60Hz

Humidity: 50 %

EUT: 8 INCH DIGITAL PHOTO FRAME

M/N: DF-F8S

Mode: USB PLAYING

Note: ZDA050200US

No.	Mk.	Freq. MHz	Reading Level dBuV	Correct Factor dB	Measure- ment dBuV	Limit dBuV	Over dB	Detector	Comment
1		0.4313	48.00	0.00	48.00	57.23	-9.23	QP	
2		0.4313	24.90	0.00	24.90	47.23	-22.33	AVG	
3		2.1484	41.60	0.00	41.60	56.00	-14.40	QP	
4	*	2.1484	40.55	0.00	40.55	46.00	-5.45	AVG	
5		14.9453	43.30	0.00	43.30	60.00	-16.70	QP	
6		14.9453	44.29	0.00	44.29	50.00	-5.71	AVG	

*:Maximum data x:Over limit !:over margin Comment: Factor build in receiver. Operator:

Conducted Emission Measurement

File :DF-F8S
 80.0 dBuV

Data :#17

Date: 2009/07/03

Time: 22:15:01

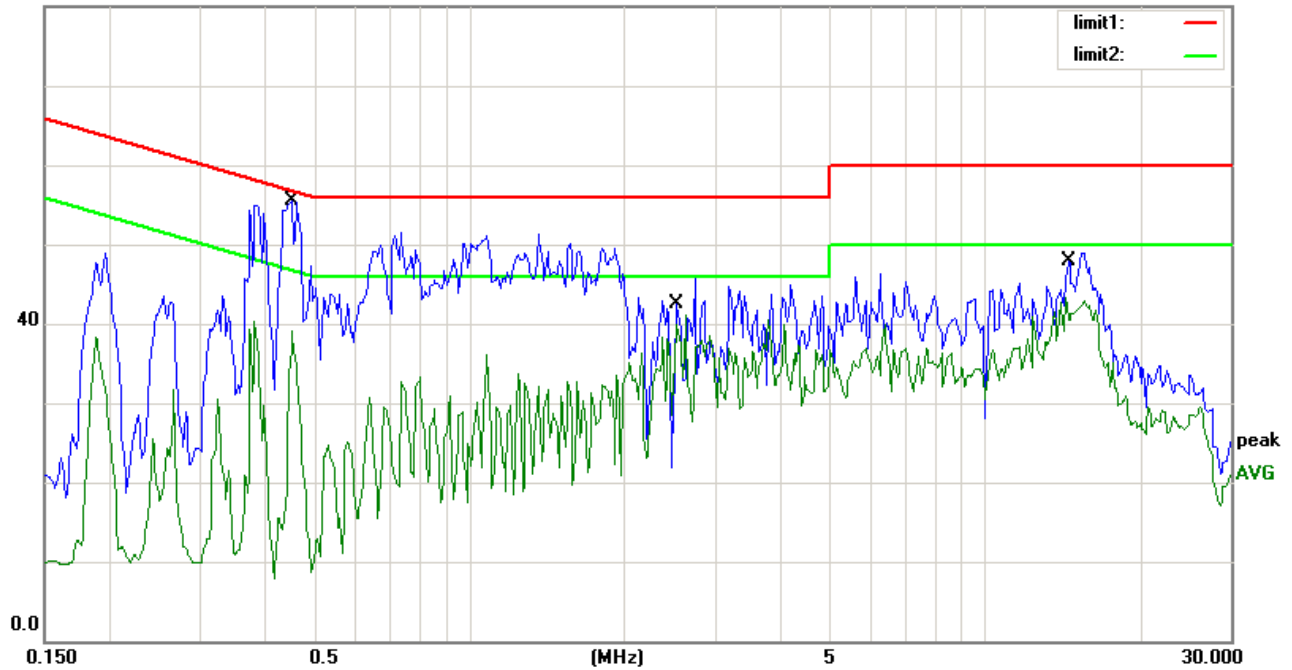

Site site #1

Phase: **N**

Temperature: 25

Limit: (CE)FCC PART 15 class B_QP

Power: AC 120V/60Hz

Humidity: 50 %

EUT: 8 INCH DIGITAL PHOTO FRAME

M/N: DF-F8S

Mode: SD CARD PLAYING

Note: ZDA050200US

No.	Mk.	Freq. MHz	Reading Level dBuV	Correct Factor dB	Measure- ment dBuV	Limit dBuV	Over dB	Detector	Comment
1		0.4547	49.20	0.00	49.20	56.79	-7.59	QP	
2	*	0.4547	41.10	0.00	41.10	46.79	-5.69	AVG	
3		2.5234	41.90	0.00	41.90	56.00	-14.10	QP	
4		2.5234	39.81	0.00	39.81	46.00	-6.19	AVG	
5		14.3633	41.50	0.00	41.50	60.00	-18.50	QP	
6		14.3633	43.37	0.00	43.37	50.00	-6.63	AVG	

*:Maximum data x:Over limit !:over margin Comment: Factor build in receiver. Operator:

Conducted Emission Measurement

File :DF-F8S
 80.0 dBuV

Data :#18

Date: 2009/07/03

Time: 22:19:34

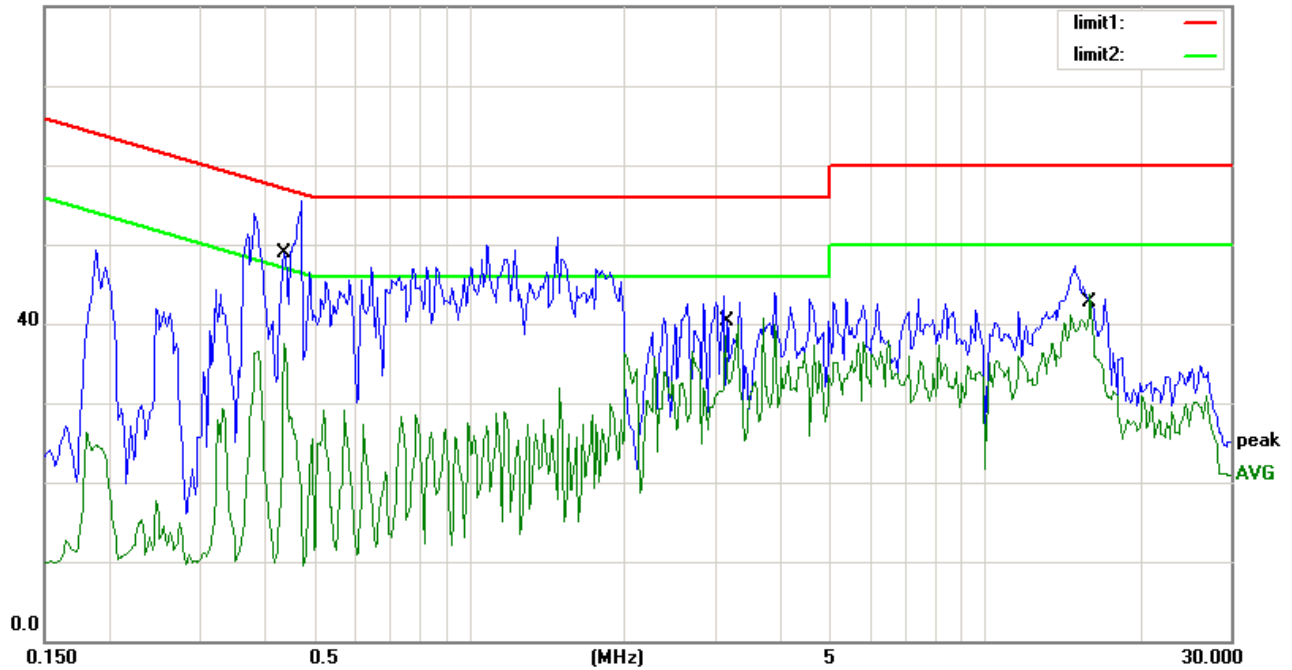

Site site #1

Phase: **L1**

Temperature: 25

Limit: (CE)FCC PART 15 class B_QP

Power: AC 120V/60Hz

Humidity: 50 %

EUT: 8 INCH DIGITAL PHOTO FRAME

M/N: DF-F8S

Mode: SD CARD PLAYING

Note: ZDA050200US

No.	Mk.	Freq. MHz	Reading Level dBuV	Correct Factor dB	Measure- ment dBuV	Limit dBuV	Over dB	Detector	Comment
1		0.4391	43.90	0.00	43.90	57.08	-13.18	QP	
2		0.4391	37.49	0.00	37.49	47.08	-9.59	AVG	
3		3.1406	38.40	0.00	38.40	56.00	-17.60	QP	
4		3.1406	38.58	0.00	38.58	46.00	-7.42	AVG	
5		15.9883	39.40	0.00	39.40	60.00	-20.60	QP	
6	*	15.9883	43.73	0.00	43.73	50.00	-6.27	AVG	

*:Maximum data x:Over limit !:over margin Comment: Factor build in receiver. Operator:

Conducted Emission Measurement

File :DF-F8S
 80.0 dBuV

Data :#25

Date: 2009-7-4

Time: 13:57:46

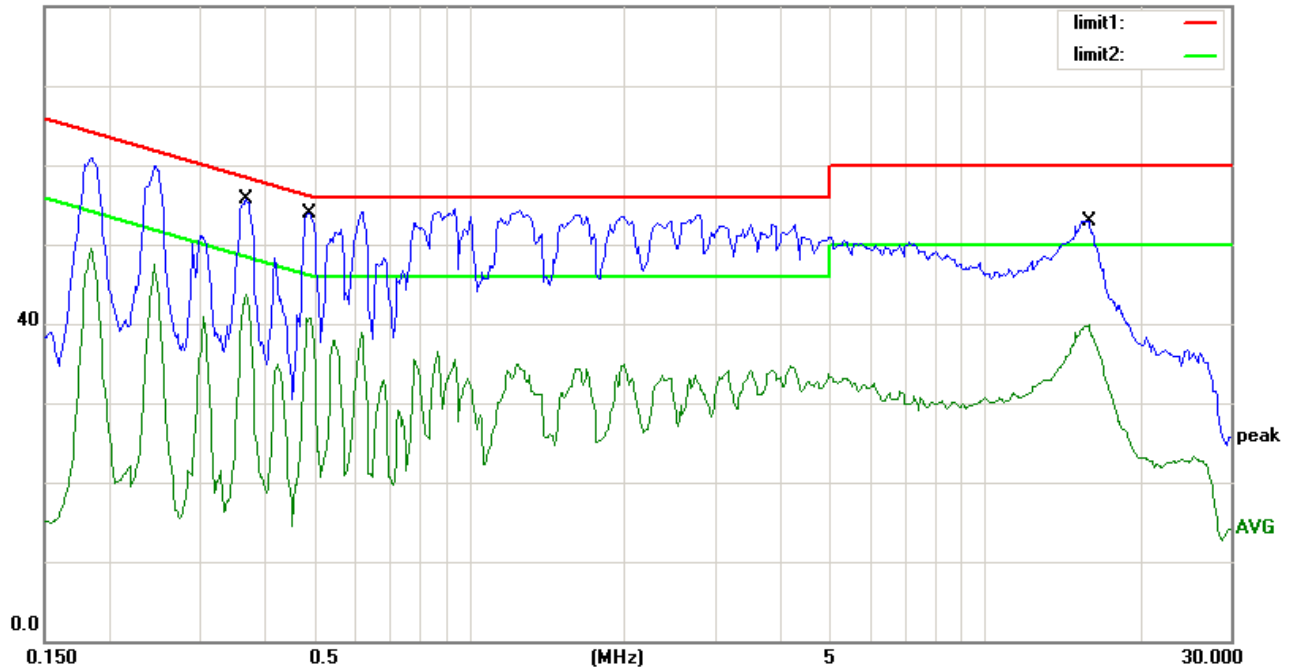

Site site #1

Phase: **L1**

Temperature: 25

Limit: (CE)FCC PART 15 class B_QP

Power: AC 120V/60Hz

Humidity: 50 %

EUT: 8 INCH DIGITAL PHOTO FRAME

M/N: DF-F8S

Mode: CONNECT TO PC

Note: ZDA050200US

No.	Mk.	Freq. MHz	Reading Level dBuV	Correct Factor dB	Measure- ment dBuV	Limit dBuV	Over dB	Detector	Comment
1		0.3712	52.10	0.00	52.10	58.47	-6.37	QP	
2		0.3712	40.90	0.00	40.90	48.47	-7.57	AVG	
3		0.4900	50.00	0.00	50.00	56.17	-6.17	QP	
4	*	0.4900	40.90	0.00	40.90	46.17	-5.27	AVG	
5		15.8250	47.30	0.00	47.30	60.00	-12.70	QP	
6		15.8250	39.40	0.00	39.40	50.00	-10.60	AVG	

*:Maximum data x:Over limit !:over margin Comment: Factor build in receiver. Operator:

Conducted Emission Measurement

File :DF-F8S
 80.0 dBuV

Data :#26

Date: 2009-7-4

Time: 14:02:49

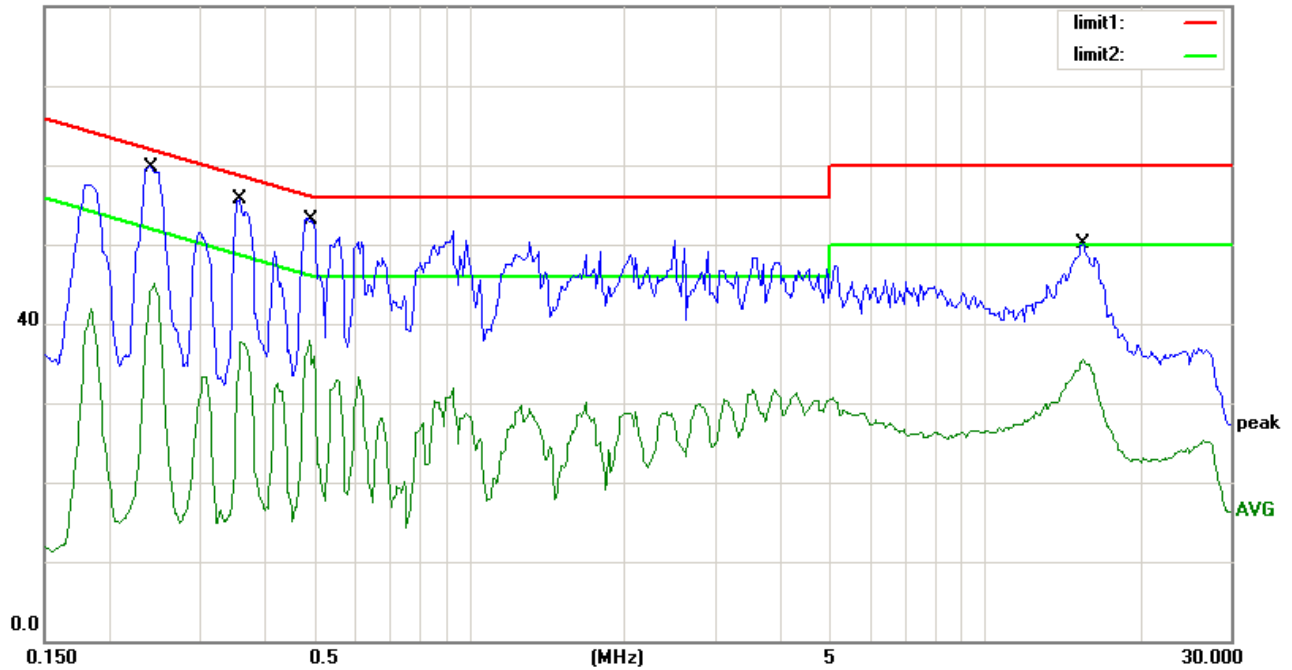

Site site #1

Phase: **N**

Temperature: 25

Limit: (CE)FCC PART 15 class B_QP

Power: AC 120V/60Hz

Humidity: 50 %

EUT: 8 INCH DIGITAL PHOTO FRAME

M/N: DF-F8S

Mode: CONNECT TO PC

Note: ZDA050200US

No.	Mk.	Freq. MHz	Reading Level dBuV	Correct Factor dB	Measure- ment dBuV	Limit dBuV	Over dB	Detector	Comment
1		0.2430	55.80	0.00	55.80	61.99	-6.19	QP	
2		0.2430	44.00	0.00	44.00	51.99	-7.99	AVG	
3		0.3615	52.40	0.00	52.40	58.69	-6.29	QP	
4		0.3615	38.60	0.00	38.60	48.69	-10.09	AVG	
5	*	0.4950	51.10	0.00	51.10	56.08	-4.98	QP	
6		0.4950	38.60	0.00	38.60	46.08	-7.48	AVG	
7		15.5250	43.40	0.00	43.40	60.00	-16.60	QP	
8		15.5250	34.70	0.00	34.70	50.00	-15.30	AVG	

*:Maximum data x:Over limit !:over margin Comment: Factor build in receiver. Operator:

Adapter XKD-C2000IC5.0-12W used for test.

Conducted Emission Measurement

File :DF-F8S
 80.0 dBuV

Data :#1

Date: 2009/07/03

Time: 20:21:48

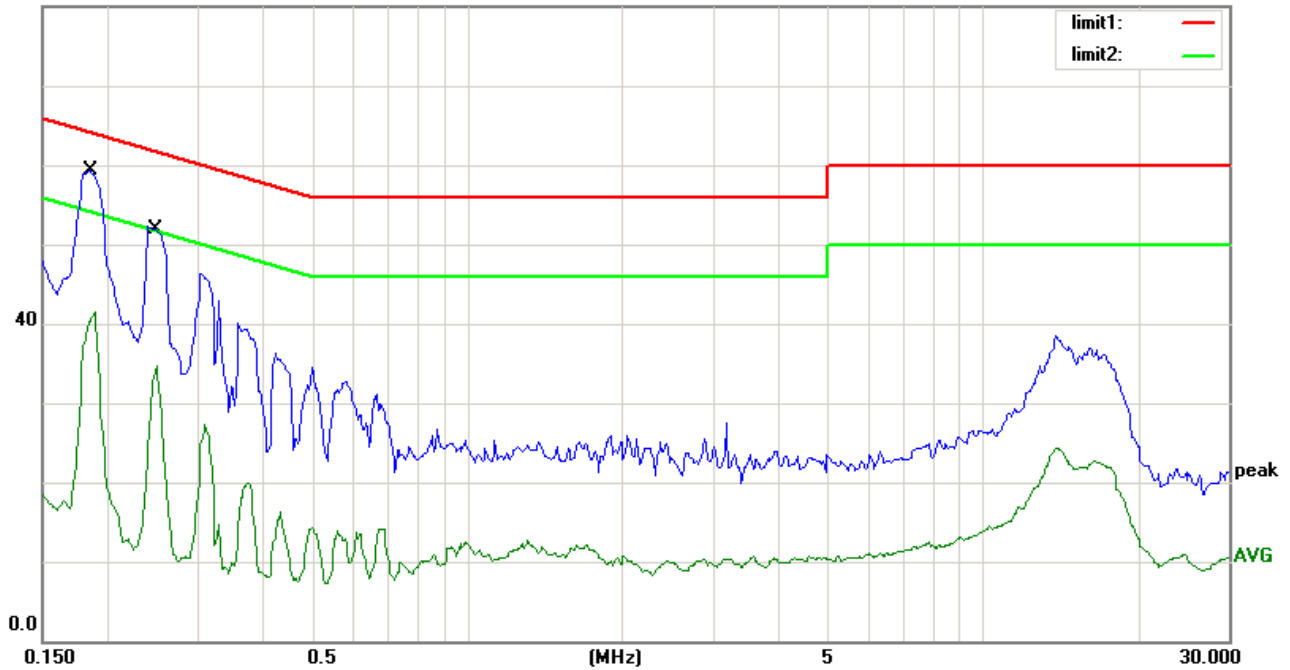

Site site #1

Phase: **L1**

Temperature: 25

Limit: (CE)FCC PART 15 class B_QP

Power: AC 120V/60Hz

Humidity: 50 %

EUT: 8 INCH DIGITAL PHOTO FRAME

M/N: DF-F8S

Mode: Memorying

Note: XKD-C2000IC5.0-12W

No.	Mk.	Freq. MHz	Reading Level dBuV	Correct Factor dB	Measure- ment dBuV	Limit dBuV	Over dB	Detector	Comment
1	*	0.1874	56.70	0.00	56.70	64.15	-7.45	QP	
2		0.1874	41.30	0.00	41.30	54.15	-12.85	AVG	
3		0.2500	48.90	0.00	48.90	61.76	-12.86	QP	
4		0.2500	34.72	0.00	34.72	51.76	-17.04	AVG	

Conducted Emission Measurement

File :DF-F8S
 80.0 dBuV

Data :#2

Date: 2009/07/03

Time: 20:26:35

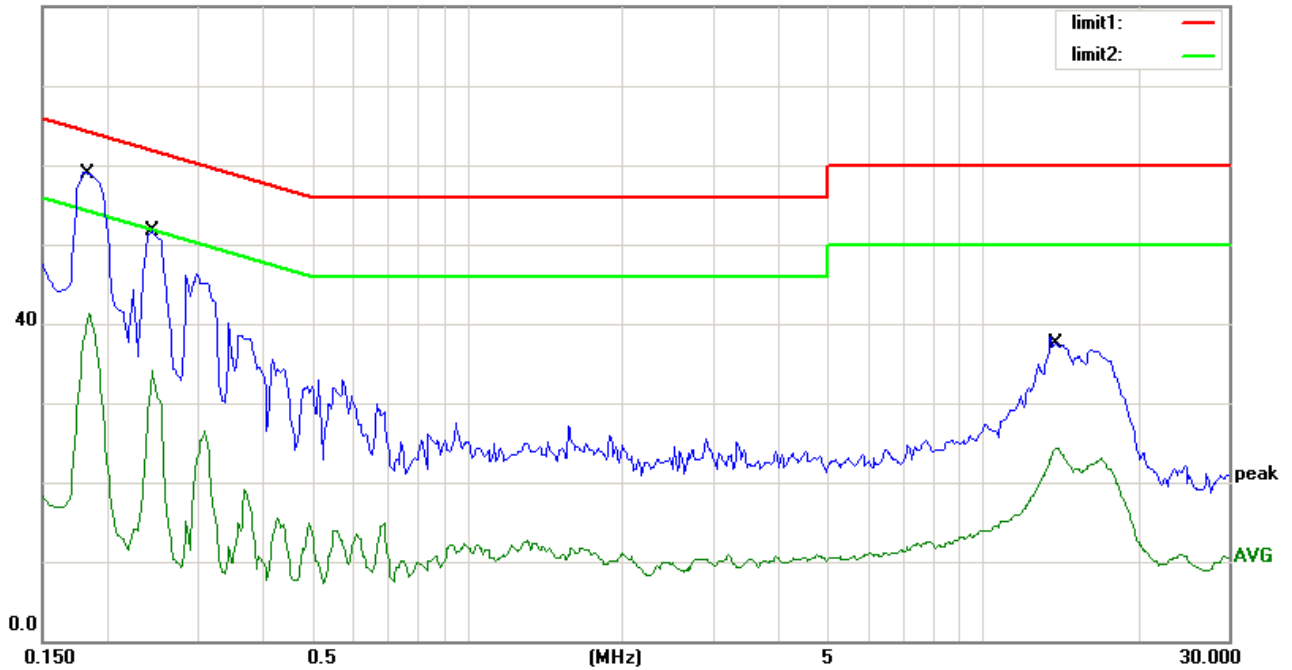

Site site #1

Phase: **N**

Temperature: 25

Limit: (CE)FCC PART 15 class B_QP

Power: AC 120V/60Hz

Humidity: 50 %

EUT: 8 INCH DIGITAL PHOTO FRAME

M/N: DF-F8S

Mode: Memorying

Note: XKD-C2000IC5.0-12W

No.	Mk.	Freq. MHz	Reading Level dBuV	Correct Factor dB	Measure- ment dBuV	Limit dBuV	Over dB	Detector	Comment
1	*	0.1850	56.30	0.00	56.30	64.26	-7.96	QP	
2		0.1850	41.30	0.00	41.30	54.26	-12.96	AVG	
3		0.2450	48.80	0.00	48.80	61.92	-13.12	QP	
4		0.2450	34.02	0.00	34.02	51.92	-17.90	AVG	
5		13.9000	32.10	0.00	32.10	60.00	-27.90	QP	
6		13.9000	24.29	0.00	24.29	50.00	-25.71	AVG	

Conducted Emission Measurement

File :DF-F8S
 80.0 dBuV

Data :#3

Date: 2009-7-3

Time: 20:45:08

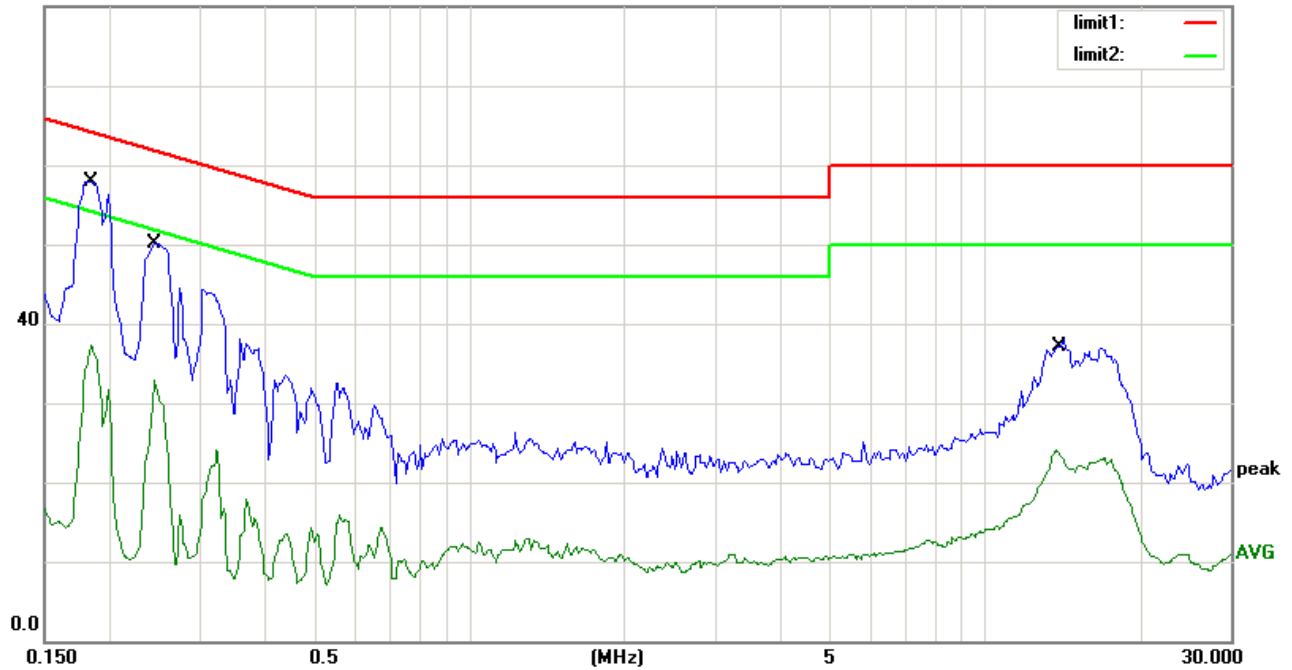

Site site #1

Phase: **L1**

Temperature: 25

Limit: (CE)FCC PART 15 class B_QP

Power: AC 120V/60Hz

Humidity: 50 %

EUT: 8 INCH DIGITAL PHOTO FRAME

M/N: DF-F8S

Mode: SD CARD PLAYING

Note: XKD-C2000IC5.0-12W

No.	Mk.	Freq. MHz	Reading Level dBuV	Correct Factor dB	Measure- ment dBuV	Limit dBuV	Over dB	Detector	Comment
1	*	0.1850	55.30	0.00	55.30	64.26	-8.96	QP	
2		0.1850	37.21	0.00	37.21	54.26	-17.05	AVG	
3		0.2450	47.90	0.00	47.90	61.92	-14.02	QP	
4		0.2450	32.90	0.00	32.90	51.92	-19.02	AVG	
5		13.7500	31.70	0.00	31.70	60.00	-28.30	QP	
6		13.7500	24.04	0.00	24.04	50.00	-25.96	AVG	

*:Maximum data x:Over limit !:over margin Comment: Factor build in receiver. Operator:

Conducted Emission Measurement

File :DF-F8S
 80.0 dBuV

Data :#4

Date: 2009-7-3

Time: 20:49:53

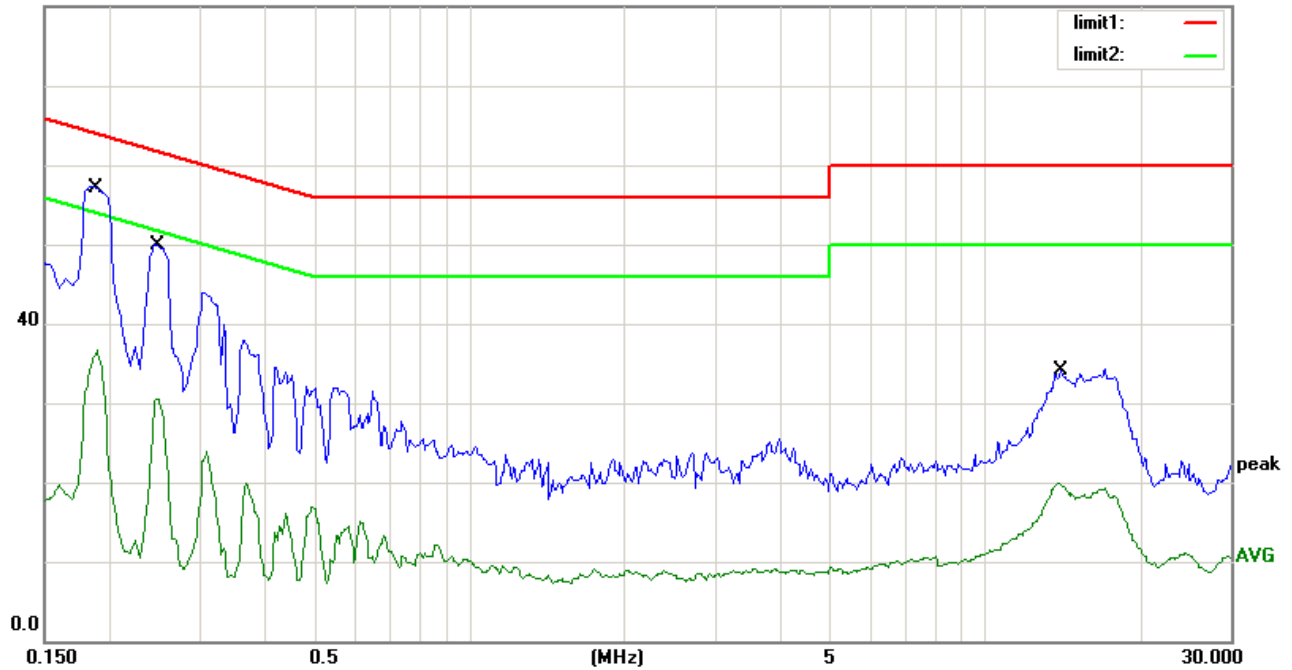

Site site #1

Phase: **N**

Temperature: 25

Limit: (CE)FCC PART 15 class B_QP

Power: AC 120V/60Hz

Humidity: 50 %

EUT: 8 INCH DIGITAL PHOTO FRAME

M/N: DF-F8S

Mode: SD CARD PLAYING

Note: XKD-C2000IC5.0-12W

No.	Mk.	Freq. MHz	Reading Level dBuV	Correct Factor dB	Measure- ment dBuV	Limit dBuV	Over dB	Detector	Comment
1	*	0.1900	54.60	0.00	54.60	64.04	-9.44	QP	
2		0.1900	36.71	0.00	36.71	54.04	-17.33	AVG	
3		0.2500	47.20	0.00	47.20	61.76	-14.56	QP	
4		0.2500	30.58	0.00	30.58	51.76	-21.18	AVG	
5		13.8750	27.40	0.00	27.40	60.00	-32.60	QP	
6		13.8750	19.96	0.00	19.96	50.00	-30.04	AVG	

*:Maximum data x:Over limit !:over margin Comment: Factor build in receiver. Operator:

Conducted Emission Measurement

File :DF-F8S
 80.0 dBuV

Data :#5

Date: 2009-7-3

Time: 20:57:05

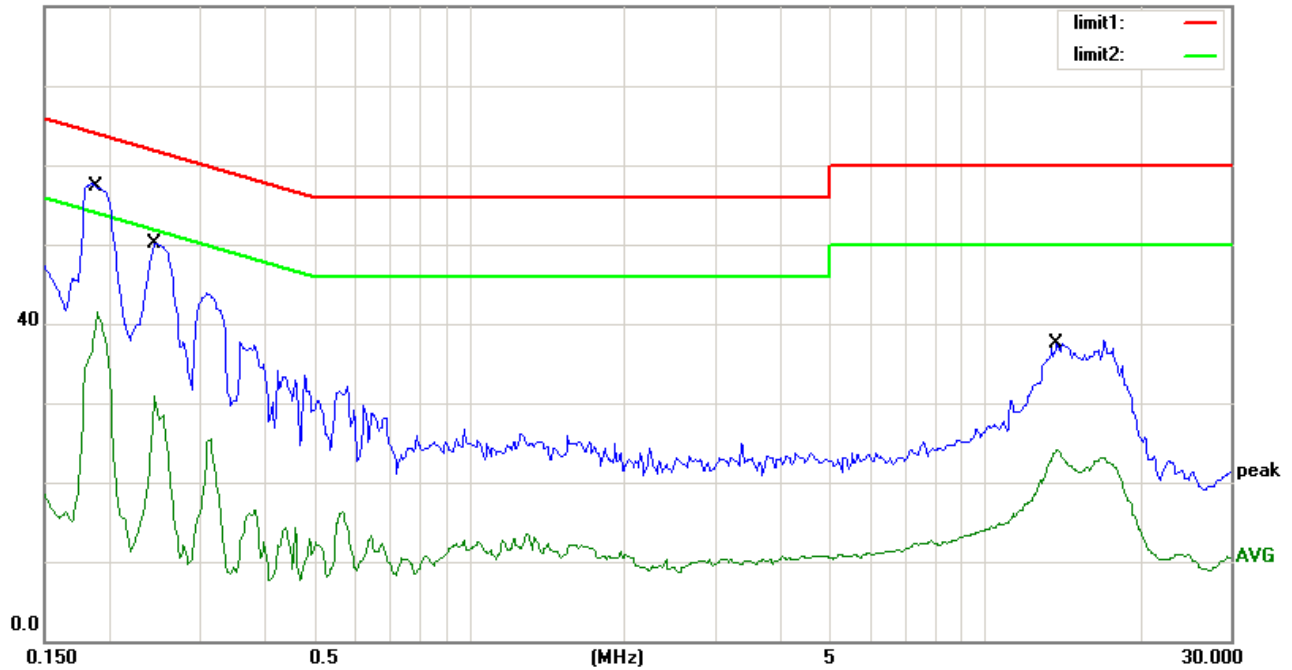

Site site #1

Limit: (CE)FCC PART 15 class B_QP
 EUT: 8 INCH DIGITAL PHOTO FRAME
 M/N: DF-F8S
 Mode: USB PLAYING
 Note: XKD-C2000IC5.0-12W

Phase: **L1**

Power: AC 120V/60Hz

Temperature: 25

Humidity: 50 %

No.	Mk.	Freq. MHz	Reading Level dBuV	Correct Factor dB	Measure- ment dBuV	Limit dBuV	Over dB	Detector	Comment
1	*	0.1900	54.60	0.00	54.60	64.04	-9.44	QP	
2		0.1900	41.50	0.00	41.50	54.04	-12.54	AVG	
3		0.2450	47.50	0.00	47.50	61.92	-14.42	QP	
4		0.2450	30.90	0.00	30.90	51.92	-21.02	AVG	
5		13.8250	31.50	0.00	31.50	60.00	-28.50	QP	
6		13.8250	24.05	0.00	24.05	50.00	-25.95	AVG	

*:Maximum data x:Over limit !:over margin Comment: Factor build in receiver. Operator:

Conducted Emission Measurement

File :DF-F8S
 80.0 dBuV

Data :#6

Date: 2009-7-3

Time: 21:01:27

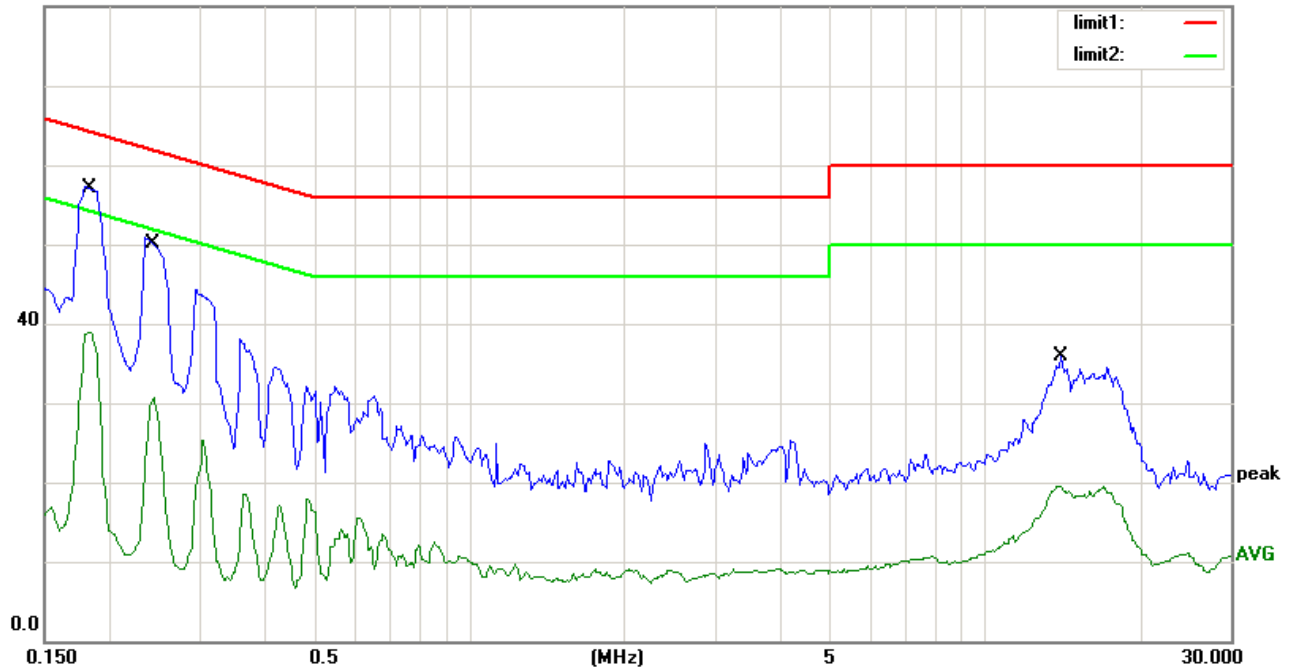

Site site #1

Phase: **N**

Temperature: 25

Limit: (CE)FCC PART 15 class B_QP

Power: AC 120V/60Hz

Humidity: 50 %

EUT: 8 INCH DIGITAL PHOTO FRAME

M/N: DF-F8S

Mode: USB PLAYING

Note: XKD-C2000IC5.0-12W

No.	Mk.	Freq. MHz	Reading Level dBuV	Correct Factor dB	Measure- ment dBuV	Limit dBuV	Over dB	Detector	Comment
1	*	0.1850	55.00	0.00	55.00	64.26	-9.26	QP	
2		0.1850	38.99	0.00	38.99	54.26	-15.27	AVG	
3		0.2450	47.30	0.00	47.30	61.92	-14.62	QP	
4		0.2450	30.74	0.00	30.74	51.92	-21.18	AVG	
5		14.0500	27.00	0.00	27.00	60.00	-33.00	QP	
6		14.0500	19.58	0.00	19.58	50.00	-30.42	AVG	

*:Maximum data x:Over limit !:over margin Comment: Factor build in receiver. Operator:

Conducted Emission Measurement

File :DF-F8S
 80.0 dBuV

Data :#29

Date: 09/07/4/

Time: 14/21/50

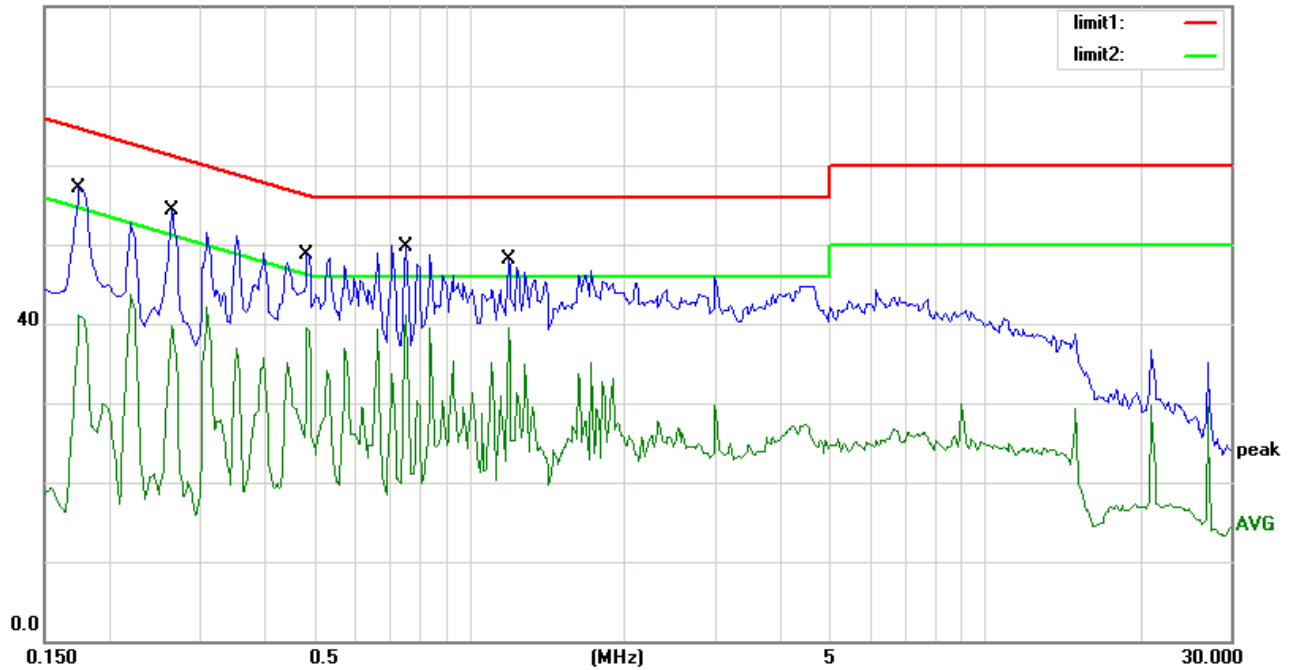

Site site #1

Phase: **L1**

Temperature: 25

Limit: (CE)FCC PART 15 class B_QP

Power: AC 120V/60Hz

Humidity: 50 %

EUT: 8 INCH DIGITAL PHOTO FRAME

M/N: DF-F8S

Mode: CONNECT TO PC

Note: XKD-C2000IC5.0-12W

No.	Mk.	Freq. MHz	Reading Level dBuV	Correct Factor dB	Measure- ment dBuV	Limit dBuV	Over dB	Detector	Comment
1		0.1750	54.90	0.00	54.90	64.72	-9.82	QP	
2		0.1750	41.50	0.00	41.50	54.72	-13.22	AVG	
3		0.2650	50.90	0.00	50.90	61.27	-10.37	QP	
4		0.2650	39.50	0.00	39.50	51.27	-11.77	AVG	
5		0.4850	44.80	0.00	44.80	56.25	-11.45	QP	
6	*	0.4850	39.90	0.00	39.90	46.25	-6.35	AVG	
7		0.7550	43.80	0.00	43.80	56.00	-12.20	QP	
8		0.7550	38.20	0.00	38.20	46.00	-7.80	AVG	
9		1.1950	43.80	0.00	43.80	56.00	-12.20	QP	
10		1.1950	38.40	0.00	38.40	46.00	-7.60	AVG	

*:Maximum data x:Over limit !:over margin Comment: Factor build in receiver. Operator:

Conducted Emission Measurement

File :DF-F8S
 80.0 dBuV

Data :#30

Date: 09/07/4/

Time: 14/33/06

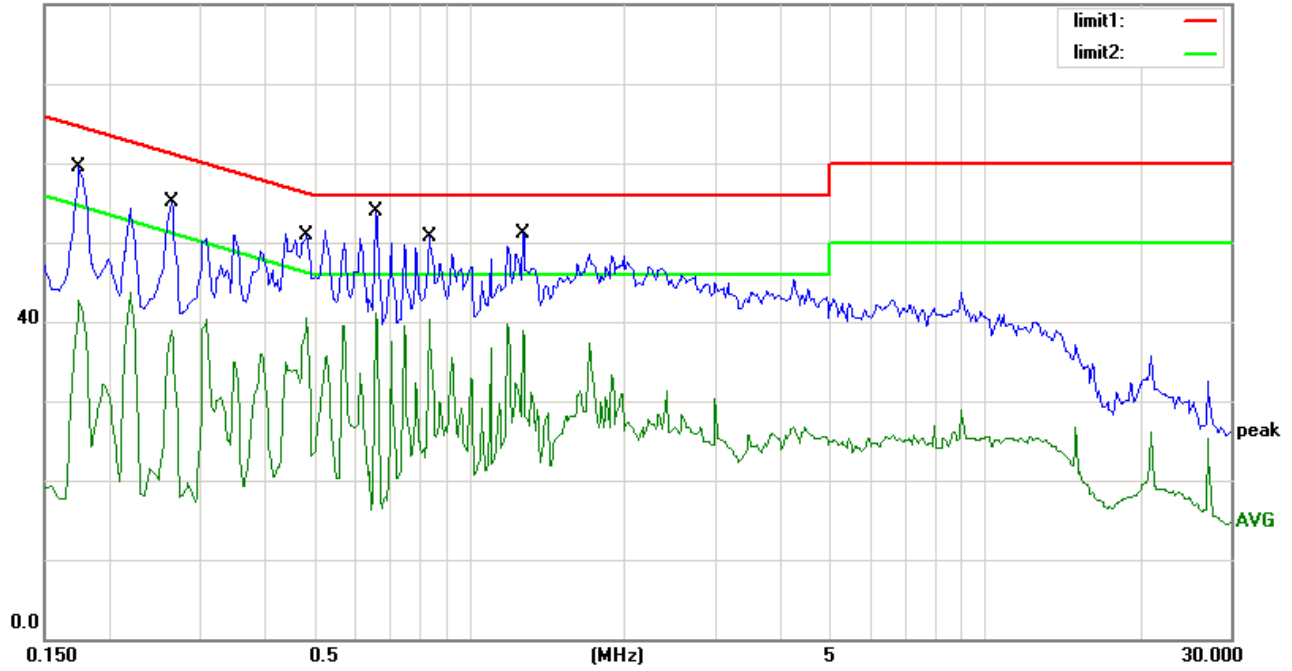

Site site #1

Phase: **N**

Temperature: 25

Limit: (CE)FCC PART 15 class B_QP

Power: AC 120V/60Hz

Humidity: 50 %

EUT: 8 INCH DIGITAL PHOTO FRAME

M/N: DF-F8S

Mode: CONNECT TO PC

Note: XKD-C2000IC5.0-12W

No.	Mk.	Freq. MHz	Reading Level dBuV	Correct Factor dB	Measure- ment dBuV	Limit dBuV	Over dB	Detector	Comment
1		0.1750	57.00	0.00	57.00	64.72	-7.72	QP	
2		0.1750	42.30	0.00	42.30	54.72	-12.42	AVG	
3		0.2650	52.00	0.00	52.00	61.27	-9.27	QP	
4		0.2650	38.40	0.00	38.40	51.27	-12.87	AVG	
5		0.4850	45.90	0.00	45.90	56.25	-10.35	QP	
6		0.4850	40.40	0.00	40.40	46.25	-5.85	AVG	
7		0.6600	50.13	0.00	50.13	56.00	-5.87	QP	
8		0.6600	40.40	0.00	40.40	46.00	-5.60	AVG	
9		0.8350	47.90	0.00	47.90	56.00	-8.10	QP	
10	*	0.8350	40.90	0.00	40.90	46.00	-5.10	AVG	
11		1.2750	45.80	0.00	45.80	56.00	-10.20	QP	
12		1.2750	38.80	0.00	38.80	46.00	-7.20	AVG	

*:Maximum data x:Over limit !:over margin Comment: Factor build in receiver. Operator:

3. RADIATED EMISSION MEASUREMENT

3.1. Test Equipment

The following test equipments are used during the radiated emission measurement:

3.1.1. For Anechoic Chamber

Item	Equipment	Manufacturer	Model No.	Serial No.	Last Cal.	Cal. Interval
1.	Spectrum Analyzer	Rohde & Schwarz	ESCI	100137	May 20, 2009	1 Year
2.	Test Receiver	Rohde & Schwarz	ESCI	100137	May 20, 2009	1 Year
3.	Bilog Antenna	Schwarzbeck	VULB9163	143	May 20, 2009	1 Year
4.	Power Amplifier	HP	8447F	OPT H64	May 20, 2009	1 Year
5.	Positioning Controller	C&C LAB	CC-C-IF	N/A	May 20, 2009	1 Year
6.	Color Monitor	SUNSPO	SP-140A	N/A	May 20, 2009	1 Year
7.	Single Line Filter	JIANLI	XL-3	N/A	May 20, 2009	1 Year
8.	Single Phase Power Line Filter	JIANLI	DL-2X100B	N/A	May 20, 2009	1 Year
9.	3 Phase Power Line Filter	JIANLI	DL-4X100B	N/A	May 20, 2009	1 Year
10.	DC Power Filter	JIANLI	DL-2X50B	N/A	May 20, 2009	1 Year
11.	Cable	Schwarzbeck	PLF-100	N/A	May 20, 2009	1 Year
12.	Cable	Rosenberger	CIL02	A0783566	May 20, 2009	1 Year
13.	Cable	Rosenberger	AK9513	AC RX1	May 20, 2009	1 Year

3.2. Block Diagram of Test Setup

3.2.1. Block diagram of connection between the EUT and simulators

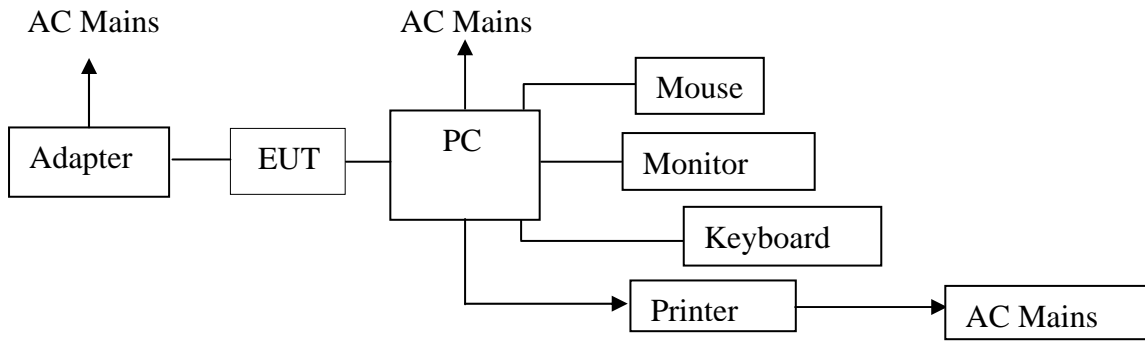

(EUT: 8 inch Digital Photo Frame)

3.2.2. Anechoic Chamber Test Setup Diagram

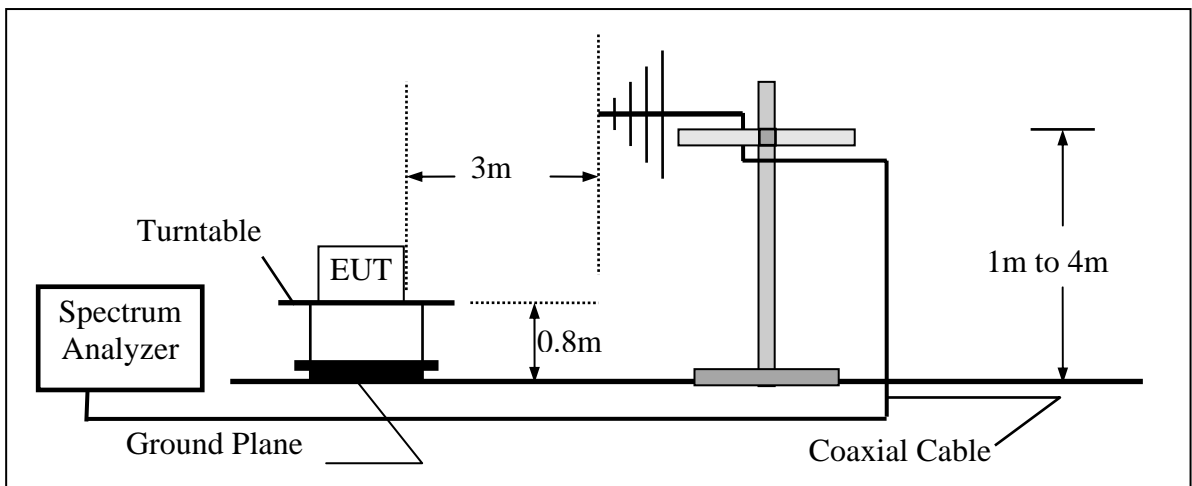

(EUT: 8 inch Digital Photo Frame)

3.3. Radiated Emission Limit

Radiated Emission Limits is as following.

FREQUENCY MHz	DISTANCE Meters	FIELD STRENGTHS LIMIT
		dB(μV)/m
30 ~ 88	3	40.0
88 ~ 216	3	43.5
216 ~ 960	3	46.0
960 ~ 1000	3	54.0
>1000	3	74.0 dB(μV)/m (peak) 54.0 dB(μV)/m (Average)

- Remark :
- (1) Emission level (dB)μV = 20 log Emission level μV/m
 - (2) The smaller limit shall apply at the cross point between two frequency bands.
 - (3) Distance is the distance in meters between the measuring instrument, antenna and the closest point of any part of the device or system.

3.4.EUT Configuration on Measurement

The following equipment are installed on Radiated Emission Measurement to meet the commission requirements and operating regulations in a manner which tends to maximize its emission characteristics in normal application.

8 inch Digital Photo Frame (EUT)

Model Number : DF-F8S

3.5.Operating Condition of EUT

3.5.1 Setup the EUT as shown in Section 3.2.

3.5.2 Turn on the power of all equipment.

3.5.3 Let the EUT work in test mode (Memorying, SD Card Playing, USB Playing, Connect to PC) and measure it.

3.6.Test Procedure

EUT and its simulators are placed on a turntable, which is 0.8 meter high above ground. The turn table can rotate 360 degrees to determine the position of the maximum emission level. EUT is set 3.0 meters away from the receiving antenna, which is mounted on a antenna tower. The antenna can be moved up and down between 1.0 meter and 4 meters to find out the maximum emission level. Broadband antenna (calibrated bilog antenna) is used as receiving antenna. Both horizontal and vertical polarization of the antenna is set on measurement. In order to find the maximum emission levels, all of the interface cables must be manipulated according to ANSI C63.4-2003 on radiated emission measurement.

The bandwidth of the EMI test receiver (R&S ESCI) set at 120KHz in 30MHz to 1000MHz, set at 1MHz above 1000MHz.

The frequency range from 30MHz to 1000MHz is checked.

3.7.Radiated Emission Noise Measurement Results

PASS.

The scanning waveforms refer to the following pages:

Adapter **ADS-12G-0605010GPCU** used for test.

Radiated Emission Measurement

File :DF-F7S

Data :#1

Date: 2009/07/04

Time: 14:53:18

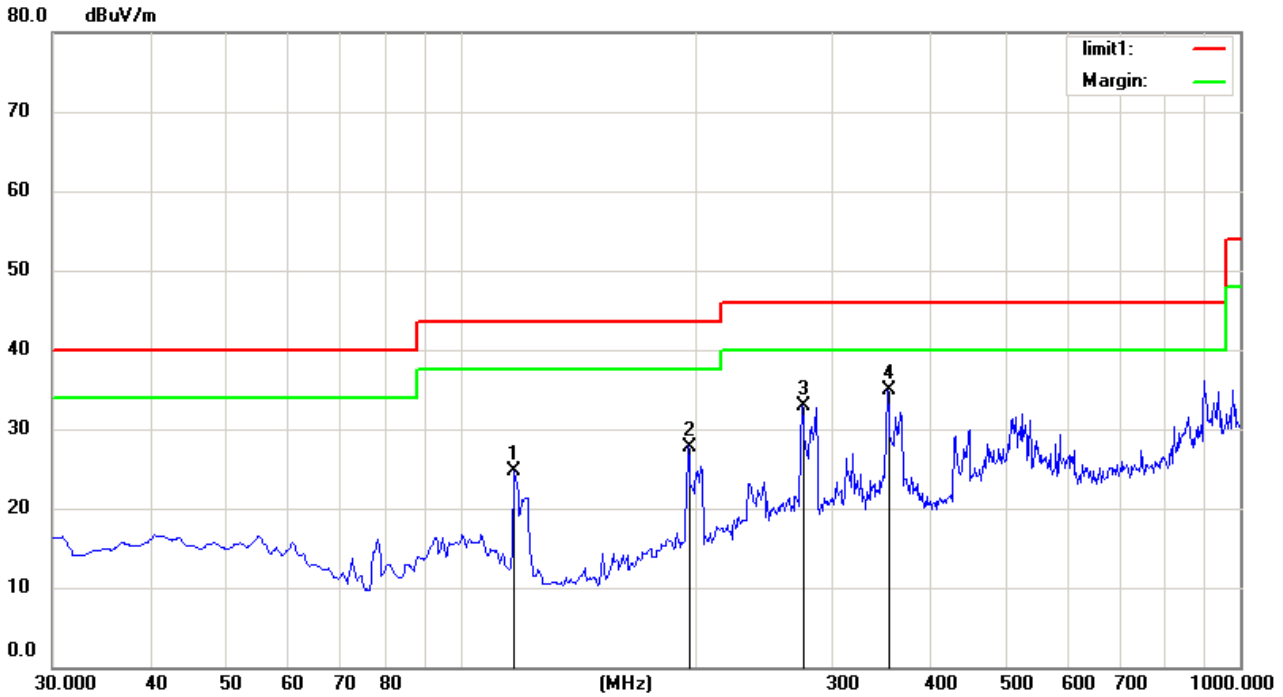

Site Chamber #1

Polarization: **Horizontal**

Temperature: 26

Limit: (RE)FCC PART 15 class B 3m

Power: AC 120V/60Hz

Humidity: 55 %

EUT: 8 INCH DIGITAL PHOTO FRAME

M/N: DF-F8S

Mode: Memorying

Note: ADS-12G-0605010GPCU

No.	Mk.	Freq. MHz	Reading Level dBuV	Correct Factor dB	Measure- ment dBuV/m	Limit dBuV/m	Over dB	Antenna Height cm	Table Degree	Comment
1		117.3000	41.23	-16.49	24.74	43.50	-18.76	QP		
2		195.8700	41.90	-14.10	27.80	43.50	-15.70	QP		
3		274.4400	44.37	-11.50	32.87	46.00	-13.13	QP		
4	*	353.0100	44.56	-9.73	34.83	46.00	-11.17	QP		

*:Maximum data x:Over limit !:over margin

Operator:

Radiated Emission Measurement

File :DF-F7S

Data :#2

Date: 2009/07/04

Time: 14:55:05

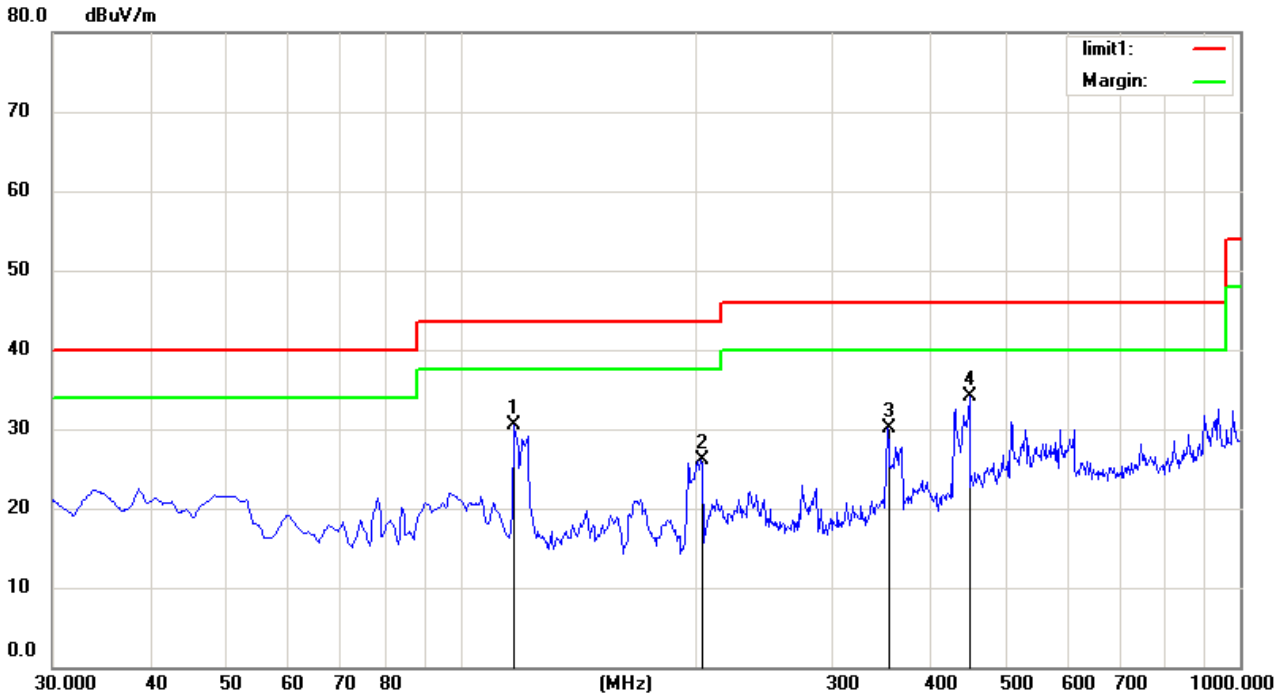

Site Chamber #1

Polarization: **Vertical**

Temperature: 26

Limit: (RE)FCC PART 15 class B 3m

Power: AC 120V/60Hz

Humidity: 55 %

EUT: 8 INCH DIGITAL PHOTO FRAME

M/N: DF-F8S

Mode: Memorying

Note: ADS-12G-0605010GPCU

No.	Mk.	Freq.	Reading Level	Correct Factor	Measurement	Limit	Over	Antenna Height	Table Degree	
		MHz	dBuV	dB	dBuV/m	dBuV/m	dB	cm	degree	Comment
1		117.3000	46.95	-16.49	30.46	43.50	-13.04	QP		
2		203.6300	39.97	-13.82	26.15	43.50	-17.35	QP		
3		353.0100	39.83	-9.73	30.10	46.00	-15.90	QP		
4	*	450.0100	42.28	-8.15	34.13	46.00	-11.87	QP		

*:Maximum data x:Over limit !:over margin

Operator:

Radiated Emission Measurement

File :DF-F7S

Data :#3

Date: 2009/07/04

Time: 16:28:32

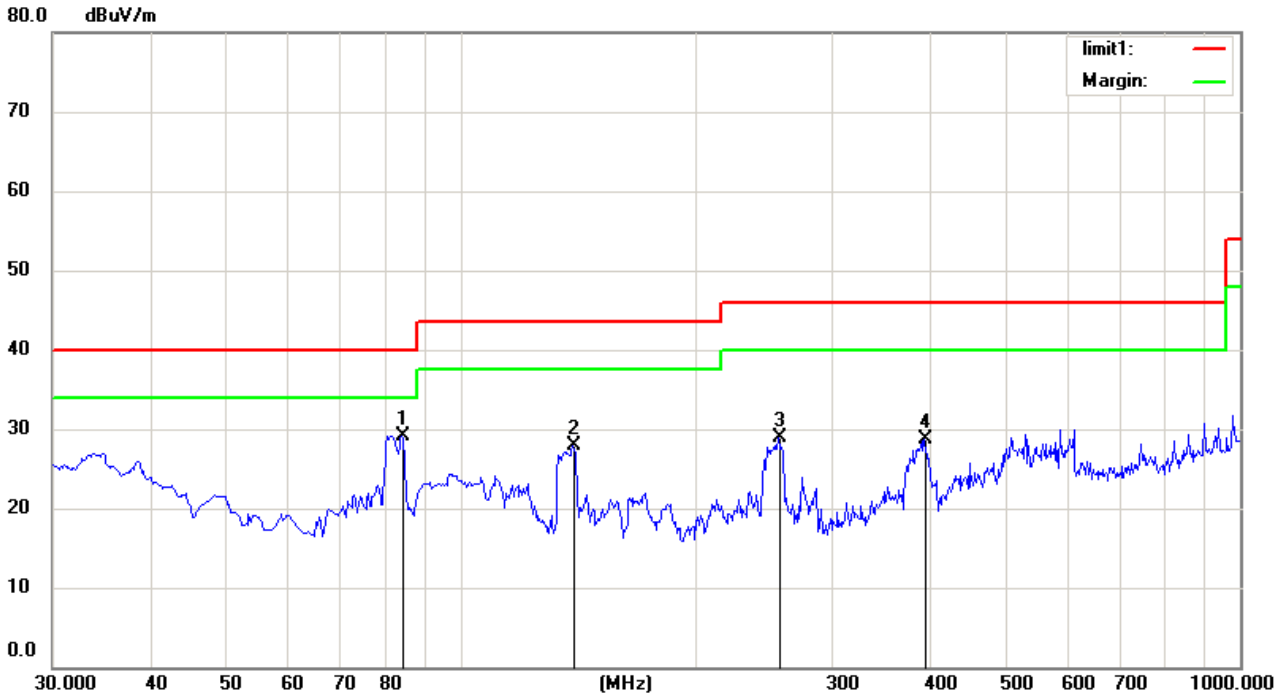

Site Chamber #1

Polarization: **Vertical**

Temperature: 26

Limit: (RE)FCC PART 15 class B 3m

Power: AC 120V/60Hz

Humidity: 55 %

EUT: 8 INCH DIGITAL PHOTO FRAME

M/N: DF-F8S

Mode: USB PLAYING

Note: ADS-12G-0605010GPCU

No.	Mk.	Freq.	Reading Level	Correct Factor	Measurement	Limit	Over	Antenna Height	Table Degree	Comment
		MHz	dBuV	dB	dBuV/m	dBuV/m	dB	cm	degree	
1	*	84.3200	46.65	-17.47	29.18	40.00	-10.82	QP		
2		139.6100	46.80	-18.90	27.90	43.50	-15.60	QP		
3		256.0100	40.81	-11.95	28.86	46.00	-17.14	QP		
4		393.7500	37.76	-9.12	28.64	46.00	-17.36	QP		

*:Maximum data x:Over limit !:over margin

Operator:

Radiated Emission Measurement

File :DF-F7S

Data :#4

Date: 2009/07/04

Time: 16:35:01

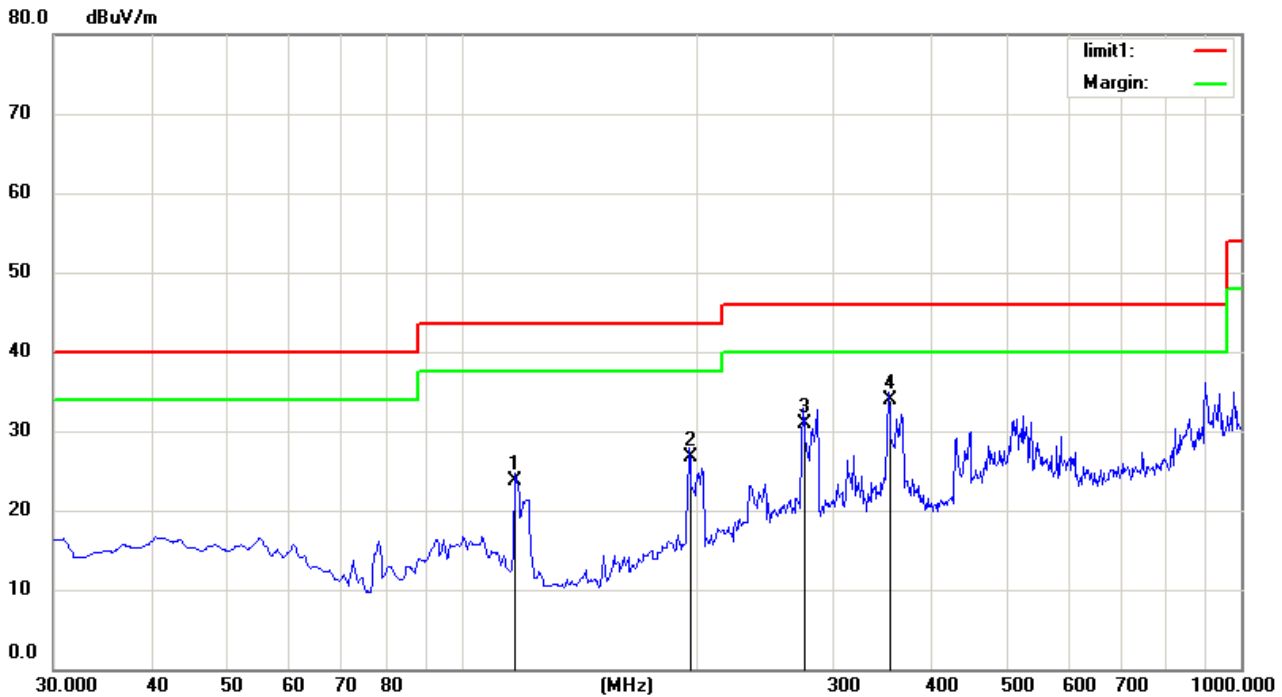

Site Chamber #1

Polarization: **Horizontal**

Temperature: 26

Limit: (RE)FCC PART 15 class B 3m

Power: AC 120V/60Hz

Humidity: 55 %

EUT: 8 INCH DIGITAL PHOTO FRAME

M/N: DF-F8S

Mode: USB PLAYING

Note: ADS-12G-0605010GPCU

No.	Mk.	Freq. MHz	Reading Level dBuV	Correct Factor dB	Measure- ment dBuV/m	Limit dBuV/m	Over dB	Antenna Height cm	Table Degree	Comment
1		117.3000	40.23	-16.49	23.74	43.50	-19.76	QP		
2		195.8700	40.90	-14.10	26.80	43.50	-16.70	QP		
3		274.4400	42.37	-11.50	30.87	46.00	-15.13	QP		
4	*	353.0100	43.56	-9.73	33.83	46.00	-12.17	QP		

*:Maximum data x:Over limit !:over margin

Operator:

Radiated Emission Measurement

File :DF-F7S

Data :#5

Date: 2009/07/04

Time: 16:40:45

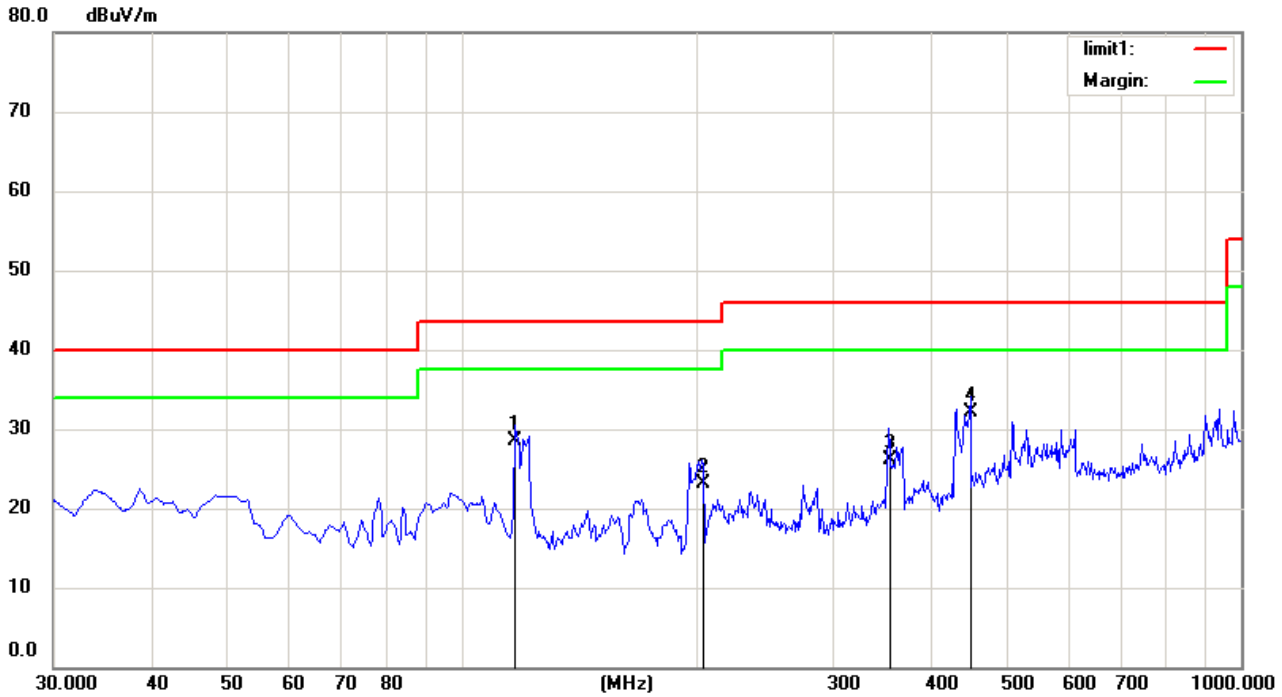

Site Chamber #1

Polarization: **Vertical**

Temperature: 26

Limit: (RE)FCC PART 15 class B 3m

Power: AC 120V/60Hz

Humidity: 55 %

EUT: 8 INCH DIGITAL PHOTO FRAME

M/N: DF-F8S

Mode: SD CARD PLAYING

Note: ADS-12G-0605010GPCU

No.	Mk.	Freq.	Reading Level	Correct Factor	Measurement	Limit	Over	Antenna Height	Table Degree		
		MHz	dBuV	dB	dBuV/m	dBuV/m	dB	Detector	cm	degree	Comment
1		117.3000	44.95	-16.49	28.46	43.50	-15.04	QP			
2		203.6300	36.97	-13.82	23.15	43.50	-20.35	QP			
3		353.0100	35.83	-9.73	26.10	46.00	-19.90	QP			
4	*	450.0100	40.28	-8.15	32.13	46.00	-13.87	QP			

*:Maximum data x:Over limit !:over margin

Operator:

Radiated Emission Measurement

File :DF-F7S

Data :#6

Date: 2009/07/04

Time: 16:46:12

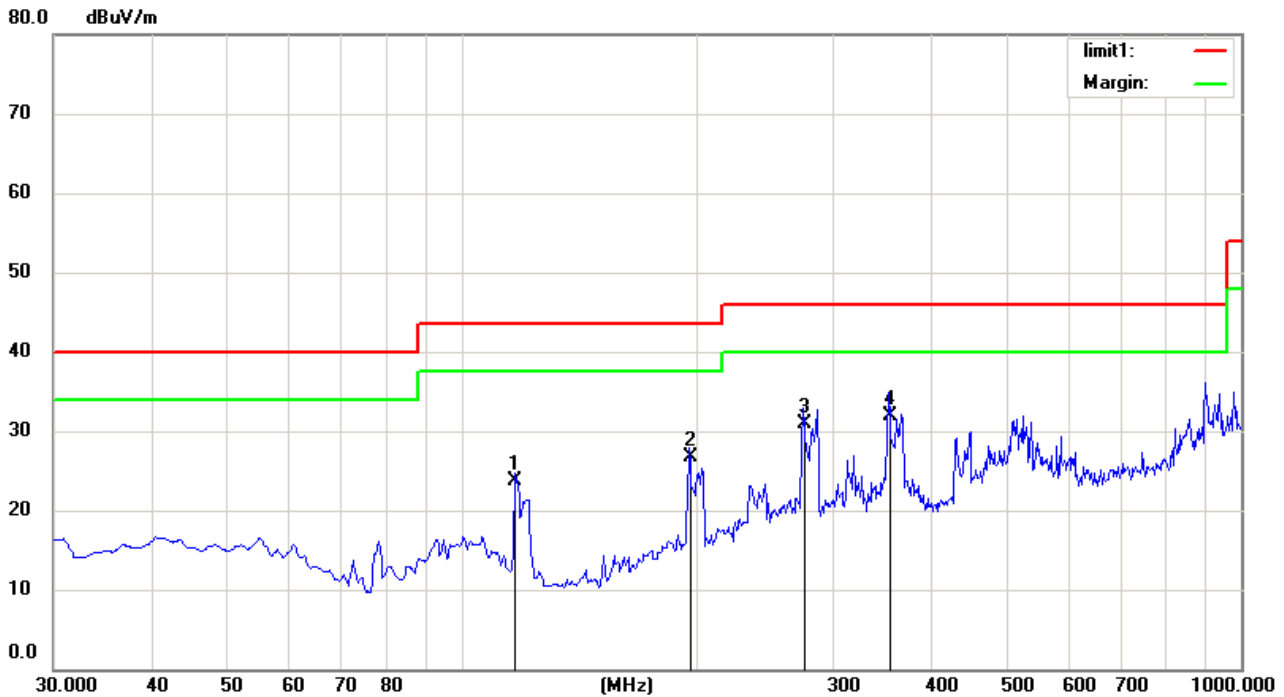

Site Chamber #1

Polarization: **Horizontal**

Temperature: 26

Limit: (RE)FCC PART 15 class B 3m

Power: AC 120V/60Hz

Humidity: 55 %

EUT: 8 INCH DIGITAL PHOTO FRAME

M/N: DF-F8S

Mode: SD CARD PLAYING

Note: ADS-12G-0605010GPCU

No.	Mk.	Freq. MHz	Reading Level dBuV	Correct Factor dB	Measure- ment dBuV/m	Limit dBuV/m	Over dB	Antenna Height cm	Table Degree	Comment
1		117.3000	40.23	-16.49	23.74	43.50	-19.76	QP		
2		195.8700	40.90	-14.10	26.80	43.50	-16.70	QP		
3		274.4400	42.37	-11.50	30.87	46.00	-15.13	QP		
4	*	353.0100	41.56	-9.73	31.83	46.00	-14.17	QP		

*:Maximum data x:Over limit !:over margin

Operator:

Radiated Emission Measurement

File :DF-F7S

Data :#7

Date: 2009-7-6

Time: 11:27:10

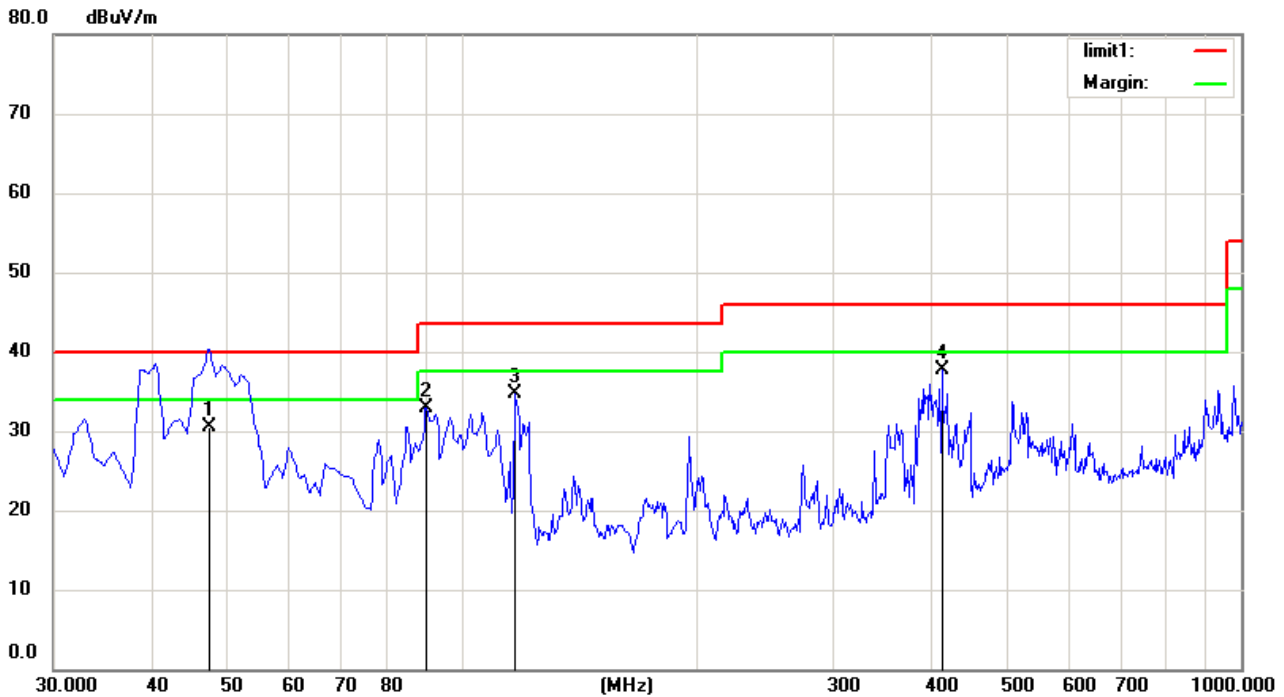

Site Chamber #1

Polarization: **Vertical**

Temperature: 26

Limit: (RE)FCC PART 15 class B 3m

Power: AC 120V/60Hz

Humidity: 55 %

EUT: 8 INCH DIGITAL PHOTO FRAME

M/N: DF-F8S

Mode:CONNECT TO PC

Note: ADS-12G-0605010GPCU

No.	Mk.	Freq. MHz	Reading Level dBuV	Correct Factor dB	Measure- ment dBuV/m	Limit dBuV/m	Over dB	Antenna Height cm	Table Degree	Comment
1		47.4600	44.85	-14.26	30.59	40.00	-9.41	QP		
2		90.1400	48.47	-15.58	32.89	43.50	-10.61	QP		
3		117.3000	51.19	-16.49	34.70	43.50	-8.80	QP		
4	*	414.1200	46.31	-8.59	37.72	46.00	-8.28	QP		

*:Maximum data x:Over limit !:over margin

Operator:

Radiated Emission Measurement

File :DF-F7S

Data :#8

Date: 2009-7-6

Time: 11:42:59

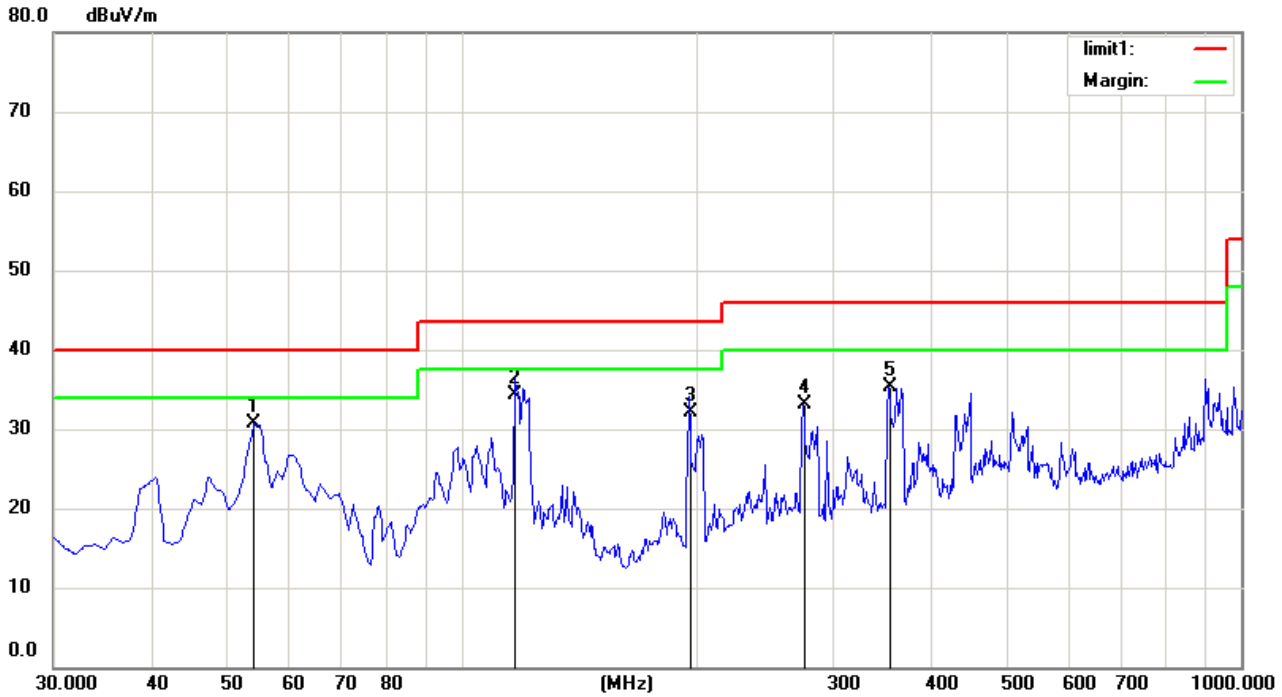

Site Chamber #1

Polarization: **Horizontal**

Temperature: 26

Limit: (RE)FCC PART 15 class B 3m

Power: AC 120V/60Hz

Humidity: 55 %

EUT: 8 INCH DIGITAL PHOTO FRAME

M/N: DF-F8S

Mode:CONNECT TO PC

Note: ADS-12G-0605010GPCU

No.	Mk.	Freq. MHz	Reading Level dBuV	Correct Factor dB	Measure- ment dBuV/m	Limit dBuV/m	Over dB	Antenna Height cm	Table Degree degree	Comment
1		54.2500	45.20	-14.59	30.61	40.00	-9.39	QP		
2	*	117.3000	50.85	-16.49	34.36	43.50	-9.14	QP		
3		195.8700	46.14	-14.10	32.04	43.50	-11.46	QP		
4		274.4400	44.53	-11.50	33.03	46.00	-12.97	QP		
5		353.0100	45.10	-9.73	35.37	46.00	-10.63	QP		

*:Maximum data x:Over limit !:over margin

Operator:

Adapter **ZDA050200US** used for test.

Radiated Emission Measurement

File :DF-F7S

Data :#1

Date: 2009/07/04

Time: 14:58:11

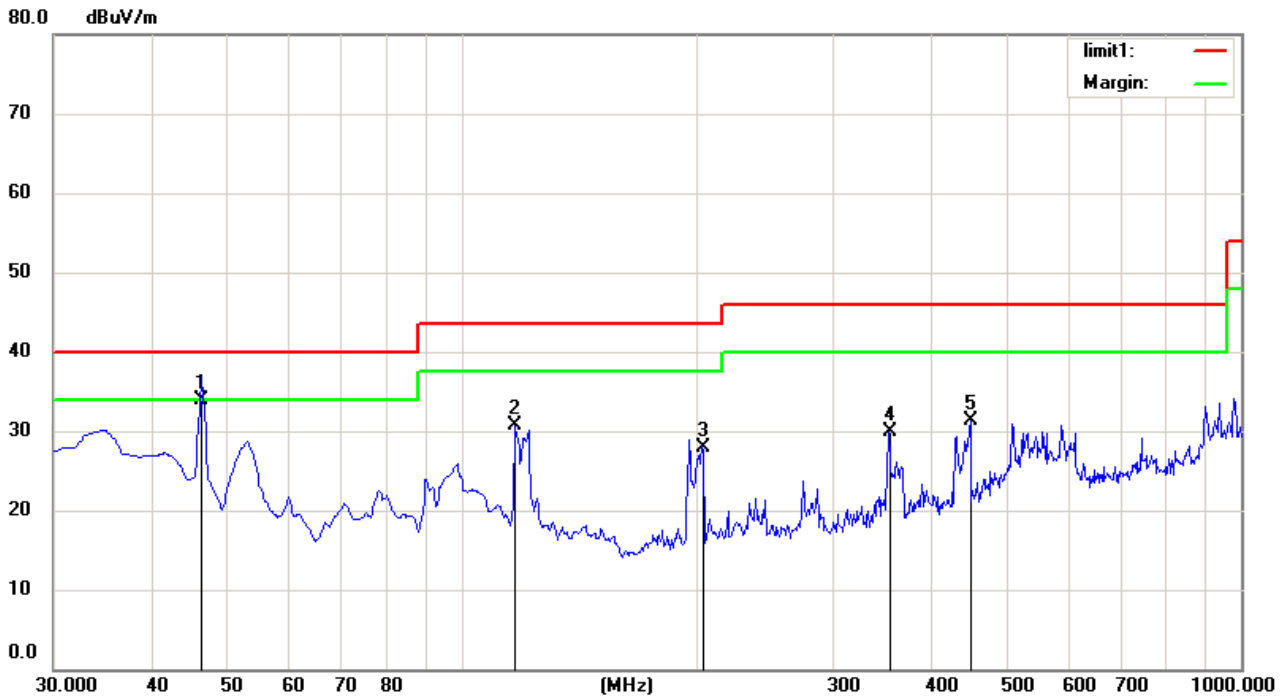

Site Chamber #1

Polarization: **Vertical**

Temperature: 26

Limit: (RE)FCC PART 15 class B 3m

Power: AC 120V/60Hz

Humidity: 55 %

EUT: 8 INCH DIGITAL PHOTO FRAME

M/N: DF-F8S

Mode:Memorying

Note: ZDA050200US

No.	Mk.	Freq.	Reading Level	Correct Factor	Measurement	Limit	Over	Antenna Height	Table Degree	
		MHz	dBuV	dB	dBuV/m	dBuV/m	dB	cm	degree	Comment
1	*	46.4900	48.20	-14.22	33.98	40.00	-6.02	QP		
2		117.3000	47.15	-16.49	30.66	43.50	-12.84	QP		
3		203.6300	41.82	-13.82	28.00	43.50	-15.50	QP		
4		353.0100	39.68	-9.73	29.95	46.00	-16.05	QP		
5		450.0100	39.41	-8.15	31.26	46.00	-14.74	QP		

*:Maximum data x:Over limit !:over margin

Operator:

Radiated Emission Measurement

File :DF-F7S

Data :#2

Date: 2009/07/04

Time: 14:59:54

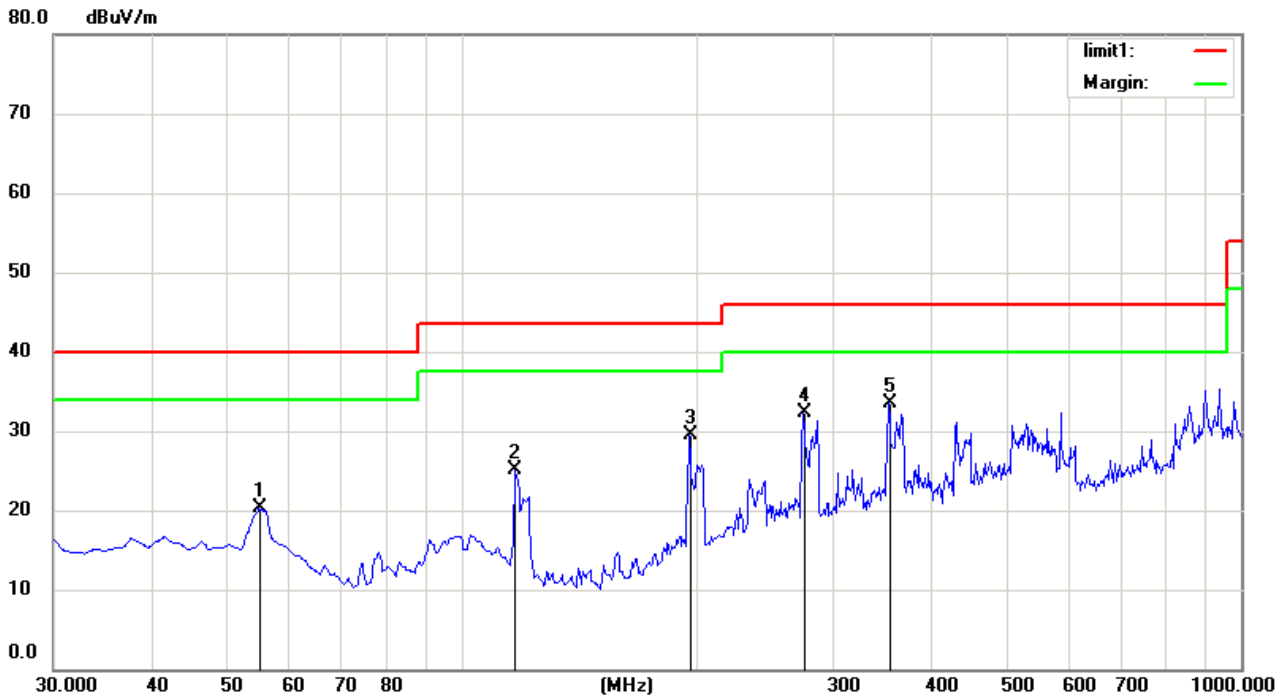

Site Chamber #1

Polarization: **Horizontal**

Temperature: 26

Limit: (RE)FCC PART 15 class B 3m

Power: AC 120V/60Hz

Humidity: 55 %

EUT: 8 INCH DIGITAL PHOTO FRAME

M/N: DF-F8S

Mode: Memorying

Note: ZDA050200US

No.	Mk.	Freq.	Reading Level	Correct Factor	Measurement	Limit	Over	Antenna Height	Table Degree	
		MHz	dBuV	dB	dBuV/m	dBuV/m	dB	Detector	cm	degree
1		55.2200	34.84	-14.63	20.21	40.00	-19.79	QP		
2		117.3000	41.63	-16.49	25.14	43.50	-18.36	QP		
3		195.8700	43.52	-14.10	29.42	43.50	-14.08	QP		
4		274.4400	43.80	-11.50	32.30	46.00	-13.70	QP		
5	*	353.0100	43.26	-9.73	33.53	46.00	-12.47	QP		

*:Maximum data x:Over limit !:over margin

Operator:

Radiated Emission Measurement

File :DF-F7S

Data :#3

Date: 2009/07/04

Time: 15:08:12

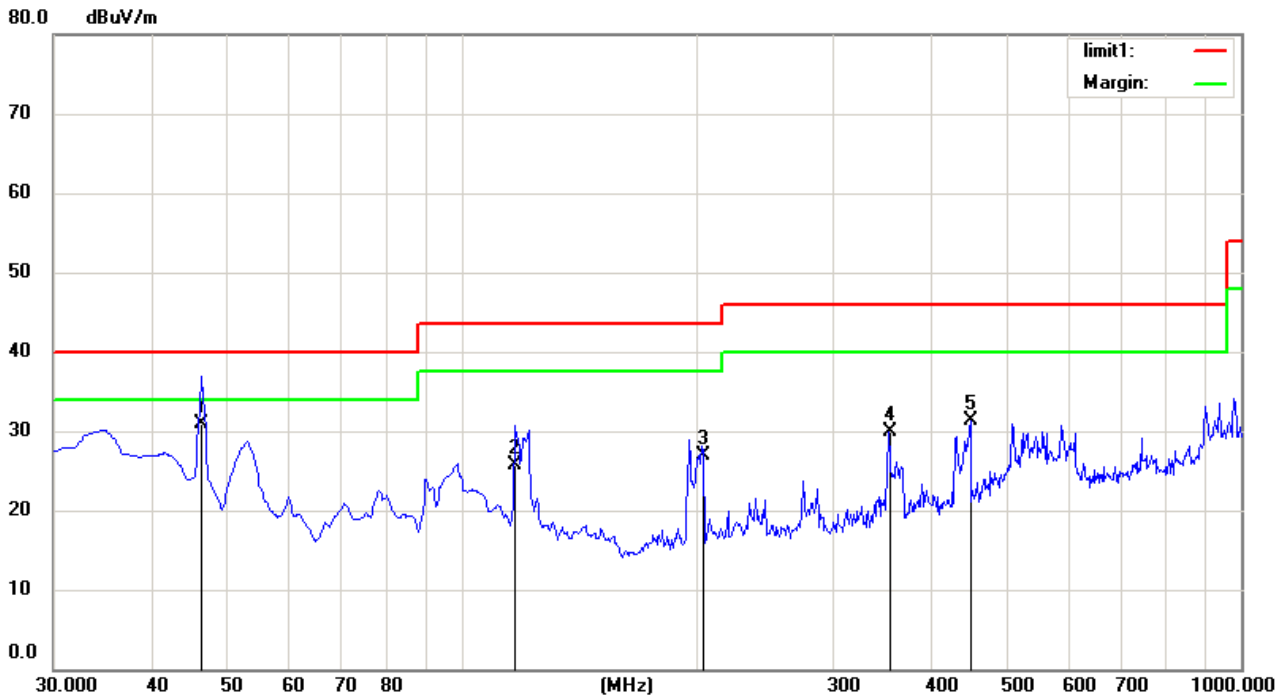

Site Chamber #1

Polarization: **Vertical**

Temperature: 26

Limit: (RE)FCC PART 15 class B 3m

Power: AC 120V/60Hz

Humidity: 55 %

EUT: 8 INCH DIGITAL PHOTO FRAME

M/N: DF-F8S

Mode:SD CARD PLAYING

Note: ZDA050200US

No.	Mk.	Freq. MHz	Reading Level dBuV	Correct Factor dB	Measure- ment dBuV/m	Limit dBuV/m	Over dB	Antenna Height cm	Table Degree	Comment
1	*	46.4900	45.20	-14.22	30.98	40.00	-9.02	QP		
2		117.3000	42.15	-16.49	25.66	43.50	-17.84	QP		
3		203.6300	40.82	-13.82	27.00	43.50	-16.50	QP		
4		353.0100	39.68	-9.73	29.95	46.00	-16.05	QP		
5		450.0100	39.41	-8.15	31.26	46.00	-14.74	QP		

*:Maximum data x:Over limit !:over margin

Operator:

Radiated Emission Measurement

File :DF-F7S

Data :#4

Date: 2009/07/04

Time: 15:15:24

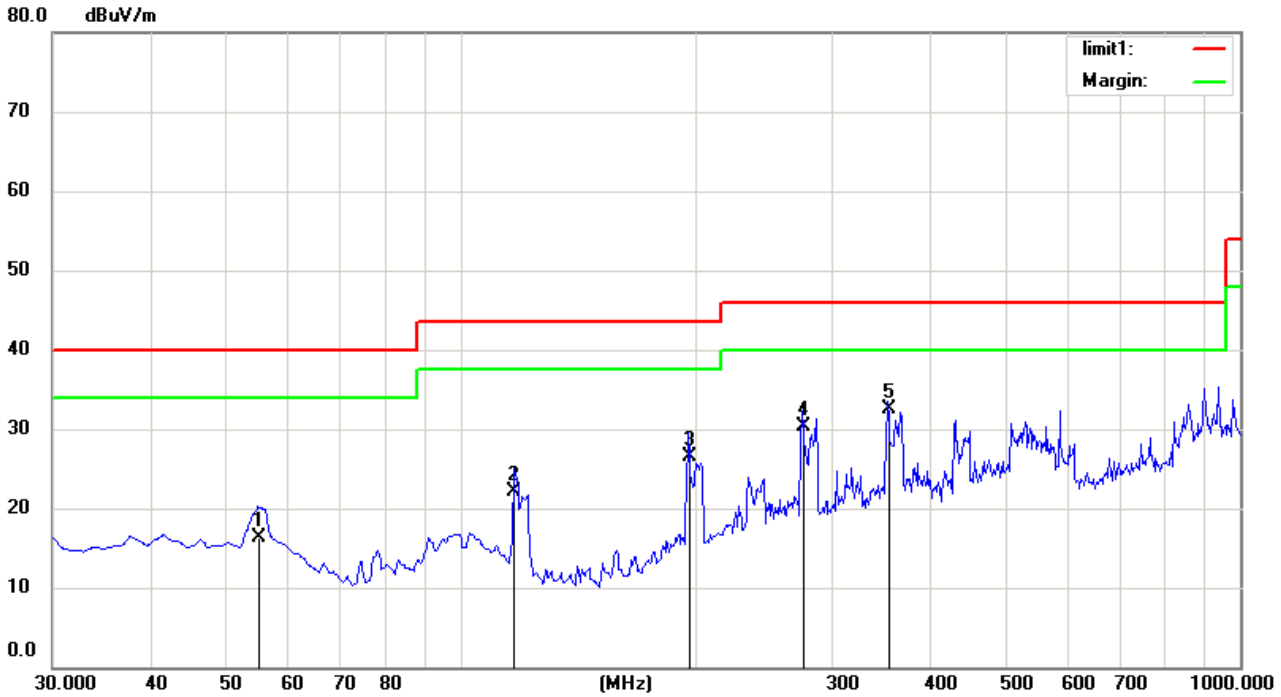

Site Chamber #1

Polarization: **Horizontal**

Temperature: 26

Limit: (RE)FCC PART 15 class B 3m

Power: AC 120V/60Hz

Humidity: 55 %

EUT: 8INCH DIGITAL PHOTO FRAME

M/N: DF-F8S

Mode: SD CARD PLAYING

Note: ZDA050200US

No.	Mk.	Freq.	Reading Level	Correct Factor	Measurement	Limit	Over	Antenna Height	Table Degree	
		MHz	dBuV	dB	dBuV/m	dBuV/m	dB	Detector	cm	degree
1		55.2200	30.84	-14.63	16.21	40.00	-23.79	QP		
2		117.3000	38.63	-16.49	22.14	43.50	-21.36	QP		
3		195.8700	40.52	-14.10	26.42	43.50	-17.08	QP		
4		274.4400	41.80	-11.50	30.30	46.00	-15.70	QP		
5	*	353.0100	42.26	-9.73	32.53	46.00	-13.47	QP		

*:Maximum data x:Over limit !:over margin

Operator:

Radiated Emission Measurement

File :DF-F7S

Data :#5

Date: 2009/07/04

Time: 15:21:23

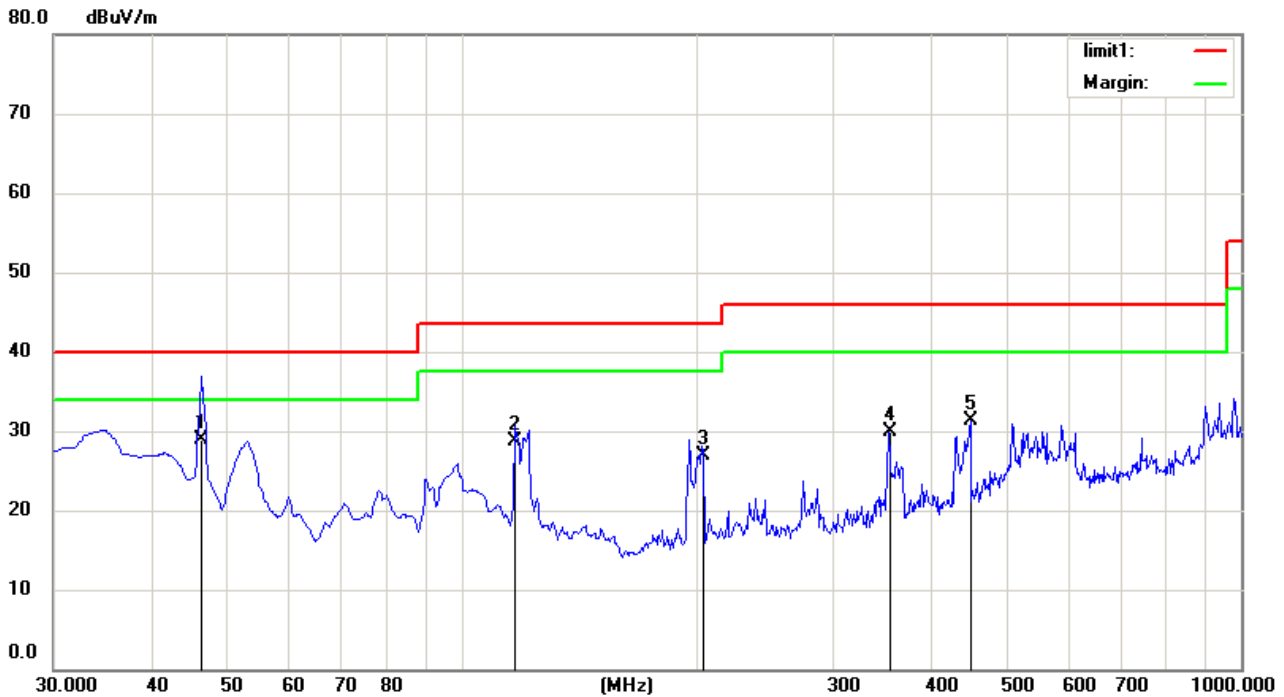

Site Chamber #1

Polarization: **Vertical**

Temperature: 26

Limit: (RE)FCC PART 15 class B 3m

Power: AC 120V/60Hz

Humidity: 55 %

EUT: 8 INCH DIGITAL PHOTO FRAME

M/N: DF-F8S

Mode: USB PLAYING

Note: ZDA050200US

No.	Mk.	Freq. MHz	Reading Level dBuV	Correct Factor dB	Measure- ment dBuV/m	Limit dBuV/m	Over dB	Antenna Height cm	Table Degree degree	Comment
1	*	46.4900	43.20	-14.22	28.98	40.00	-11.02	QP		
2		117.3000	45.15	-16.49	28.66	43.50	-14.84	QP		
3		203.6300	40.82	-13.82	27.00	43.50	-16.50	QP		
4		353.0100	39.68	-9.73	29.95	46.00	-16.05	QP		
5		450.0100	39.41	-8.15	31.26	46.00	-14.74	QP		

*:Maximum data x:Over limit !:over margin

Operator:

Radiated Emission Measurement

File :DF-F7S

Data :#6

Date: 2009/07/04

Time: 15:27:12

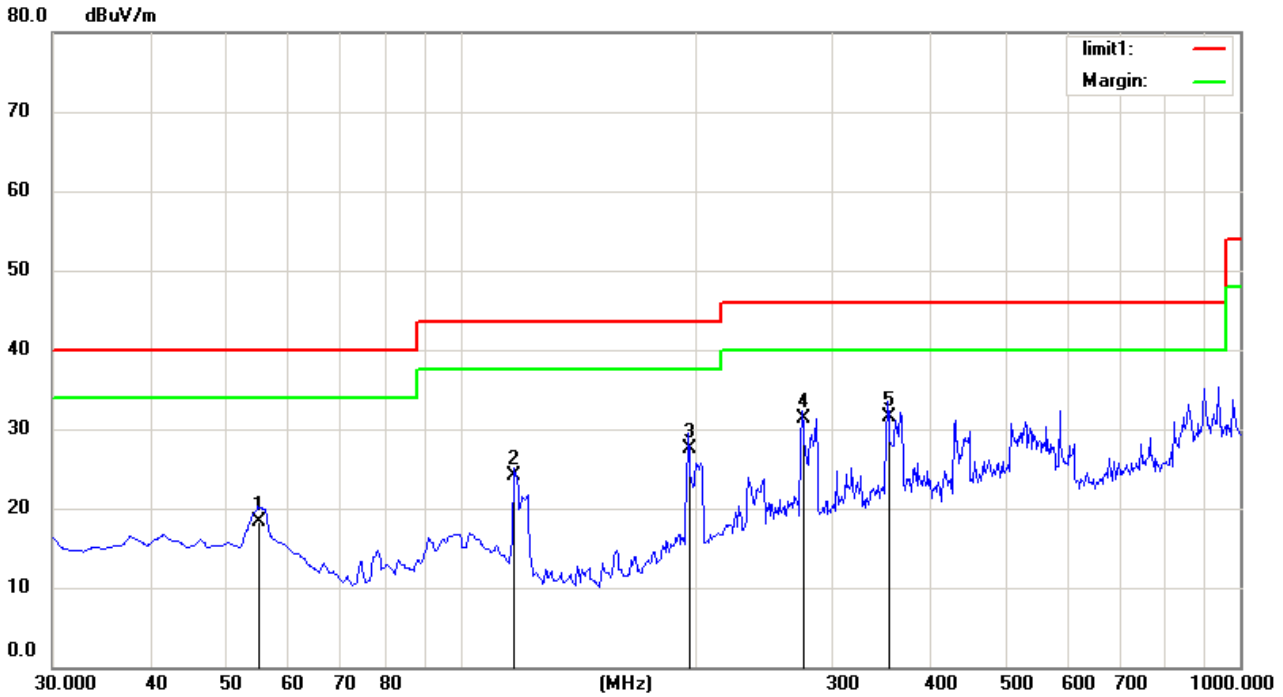

Site Chamber #1

Polarization: **Horizontal**

Temperature: 26

Limit: (RE)FCC PART 15 class B 3m

Power: AC 120V/60Hz

Humidity: 55 %

EUT: 8 INCH DIGITAL PHOTO FRAME

M/N: DF-F8S

Mode: USB PLAYING

Note: ZDA050200US

No.	Mk.	Freq.	Reading Level	Correct Factor	Measurement	Limit	Over	Antenna Height	Table Degree	
		MHz	dBuV	dB	dBuV/m	dBuV/m	dB	cm	degree	Comment
1		55.2200	32.84	-14.63	18.21	40.00	-21.79	QP		
2		117.3000	40.63	-16.49	24.14	43.50	-19.36	QP		
3		195.8700	41.52	-14.10	27.42	43.50	-16.08	QP		
4		274.4400	42.80	-11.50	31.30	46.00	-14.70	QP		
5	*	353.0100	41.26	-9.73	31.53	46.00	-14.47	QP		

*:Maximum data x:Over limit !:over margin

Operator:

Radiated Emission Measurement

File :DF-F7S

Data :#7

Date: 2009-7-6

Time: 11:47:25

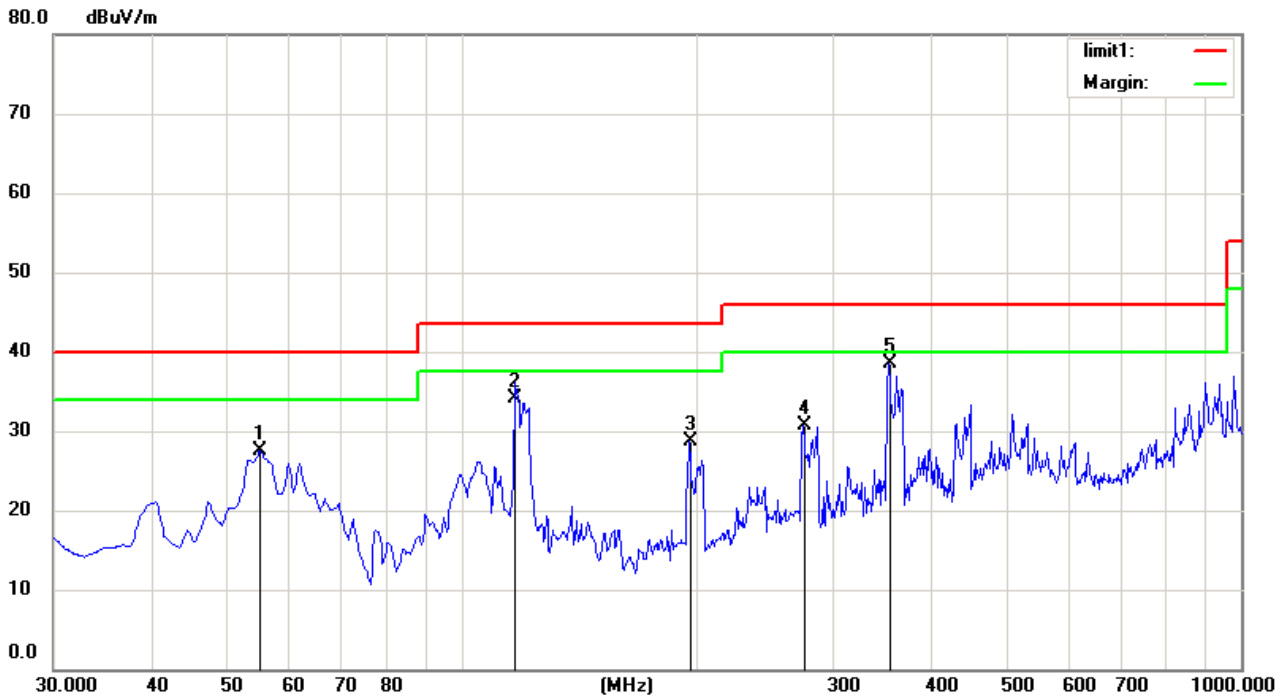

Site Chamber #1

Polarization: **Horizontal**

Temperature: 26

Limit: (RE)FCC PART 15 class B 3m

Power: AC 120V/60Hz

Humidity: 55 %

EUT: 8 INCH DIGITAL PHOTO FRAME

M/N: DF-F8S

Mode:CONNECT TO PC

Note: ZDA050200US

No.	Mk.	Freq. MHz	Reading Level dBuV	Correct Factor dB	Measure- ment dBuV/m	Limit dBuV/m	Over dB	Antenna Height cm	Table Degree degree	Comment
1		55.2200	42.09	-14.63	27.46	40.00	-12.54	QP		
2		117.3000	50.51	-16.49	34.02	43.50	-9.48	QP		
3		195.8700	42.74	-14.10	28.64	43.50	-14.86	QP		
4		274.4400	42.16	-11.50	30.66	46.00	-15.34	QP		
5	*	353.0100	48.22	-9.73	38.49	46.00	-7.51	AVG		

*:Maximum data x:Over limit !:over margin

Operator:

Radiated Emission Measurement

File :DF-F7S

Data :#8

Date: 2009-7-6

Time: 11:49:12

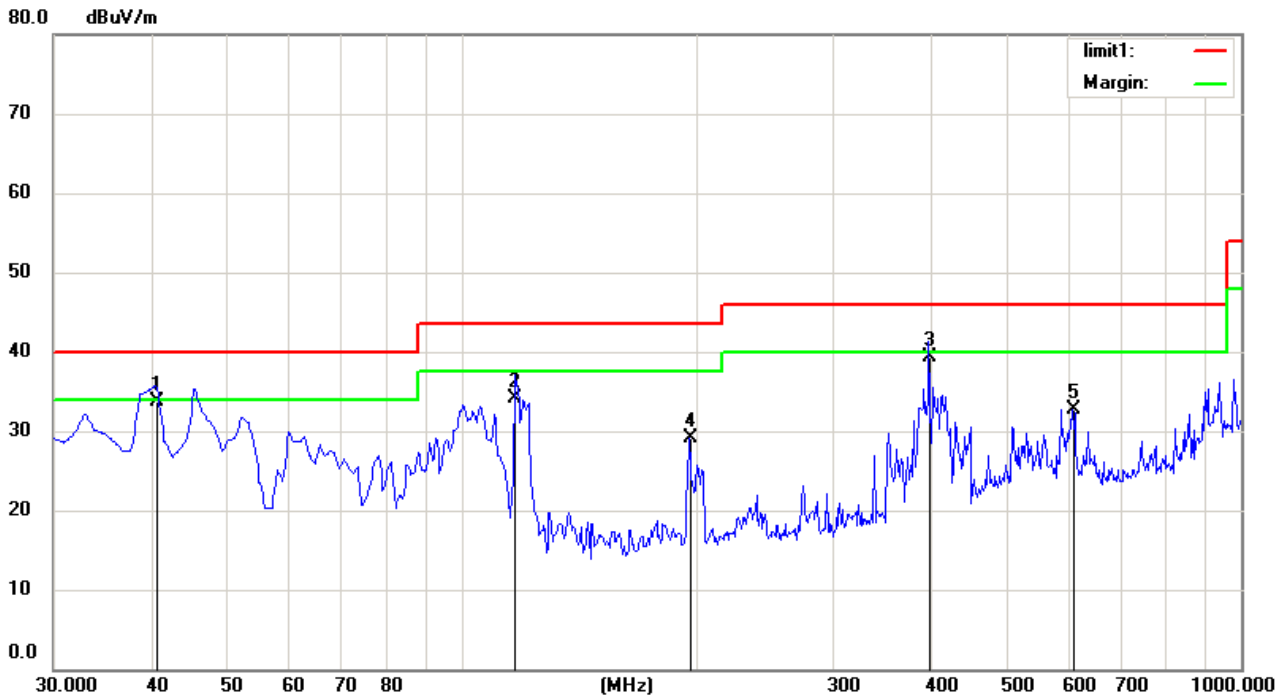

Site Chamber #1

Polarization: **Vertical**

Temperature: 26

Limit: (RE)FCC PART 15 class B 3m

Power: AC 120V/60Hz

Humidity: 55 %

EUT: 8 INCH DIGITAL PHOTO FRAME

M/N: DF-F8S

Mode:CONNECT TO PC

Note: ZDA050200US

No.	Mk.	Freq.	Reading Level	Correct Factor	Measurement	Limit	Over	Antenna Height	Table Degree	Comment
		MHz	dBuV	dB	dBuV/m	dBuV/m	dB	cm	degree	
1	*	40.6700	47.89	-14.13	33.76	40.00	-6.24	QP		
2		117.3000	50.52	-16.49	34.03	43.50	-9.47	QP		
3		398.6000	48.32	-9.01	39.31	46.00	-6.69	QP		
4		195.8700	43.21	-14.10	29.11	43.50	-14.39	QP		
5		609.0900	38.08	-5.33	32.75	46.00	-13.25	QP		

*:Maximum data x:Over limit !:over margin

Operator:

Adapter XKD-C2000IC5.0-12W used for test.

Radiated Emission Measurement

File :DF-F7S

Data :#1

Date: 2009/07/04

Time: 14:23:24

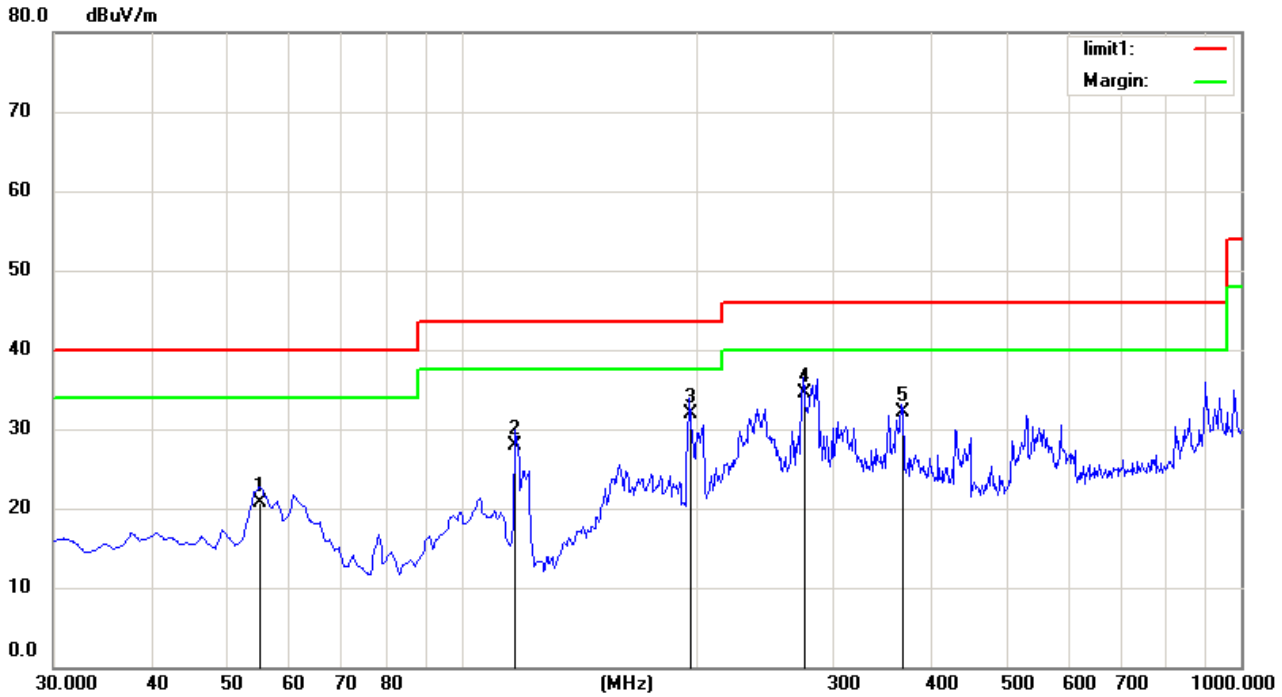

Site Chamber #1

Polarization: **Horizontal**

Temperature: 26

Limit: (RE)FCC PART 15 class B 3m

Power: AC 120V/60Hz

Humidity: 55 %

EUT: 8 INCH DIGITAL PHOTO FRAME

M/N: DF-F8S

Mode: Memorying

Note: XKD-C2000IC5.0-12W

No.	Mk.	Freq. MHz	Reading Level dBuV	Correct Factor dB	Measure- ment dBuV/m	Limit dBuV/m	Over dB	Antenna Height cm	Table Degree degree	Comment
1		55.2200	35.39	-14.63	20.76	40.00	-19.24	QP		
2		117.3000	44.39	-16.49	27.90	43.50	-15.60	QP		
3		195.8700	46.01	-14.10	31.91	43.50	-11.59	QP		
4	*	274.4400	46.00	-11.50	34.50	46.00	-11.50	QP		
5		367.5600	41.57	-9.55	32.02	46.00	-13.98	QP		

*:Maximum data x:Over limit !:over margin

Operator:

Radiated Emission Measurement

File :DF-F7S

Data :#2

Date: 2009/07/04

Time: 14:26:22

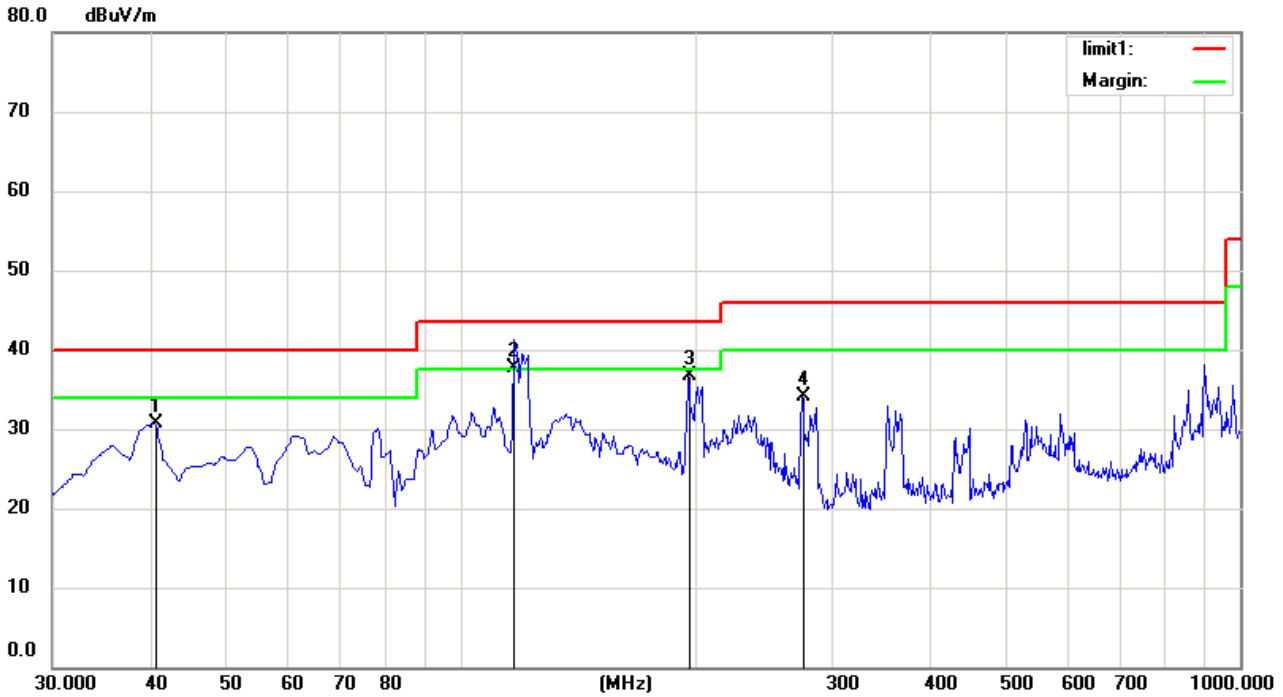

Site Chamber #1

Polarization: **Vertical**

Temperature: 26

Limit: (RE)FCC PART 15 class B 3m

Power: AC 120V/60Hz

Humidity: 55 %

EUT: 8 INCH DIGITAL PHOTO FRAME

M/N: DF-F8S

Mode: Memorying

Note: XKD-C2000IC5.0-12W

No.	Mk.	Freq. MHz	Reading Level dBuV	Correct Factor dB	Measure- ment dBuV/m	Limit dBuV/m	Over dB	Antenna Height cm	Table Degree degree	Comment
1		40.6700	44.83	-14.13	30.70	40.00	-9.30	QP		
2	*	117.3000	54.20	-16.49	37.71	43.50	-5.79	QP		
3		195.8700	50.74	-14.10	36.64	43.50	-6.86	QP		
4		274.4400	45.54	-11.50	34.04	46.00	-11.96	QP		

*:Maximum data x:Over limit !:over margin

Operator:

Radiated Emission Measurement

File :DF-F7S

Data :#3

Date: 2009/07/04

Time: 16:05:02

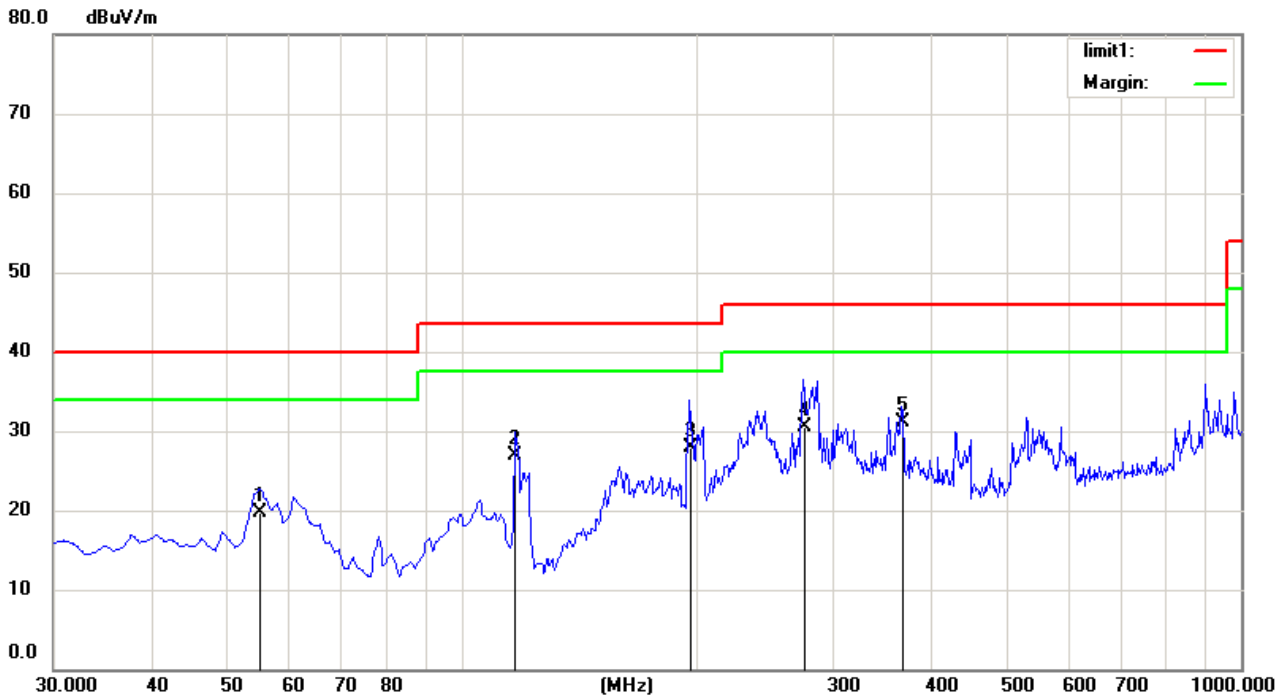

Site Chamber #1

Polarization: **Horizontal**

Temperature: 26

Limit: (RE)FCC PART 15 class B 3m

Power: AC 120V/60Hz

Humidity: 55 %

EUT: 8 INCH DIGITAL PHOTO FRAME

M/N: DF-F8S

Mode: SD CARD PLAYING

Note: XKD-C2000IC5.0-12W

No.	Mk.	Freq.	Reading Level	Correct Factor	Measurement	Limit	Over	Antenna Height	Table Degree	
		MHz	dBuV	dB	dBuV/m	dBuV/m	dB	Detector	cm	degree
1		55.2200	34.39	-14.63	19.76	40.00	-20.24	QP		
2		117.3000	43.39	-16.49	26.90	43.50	-16.60	QP		
3		195.8700	42.01	-14.10	27.91	43.50	-15.59	QP		
4		274.4400	42.00	-11.50	30.50	46.00	-15.50	QP		
5	*	367.5600	40.57	-9.55	31.02	46.00	-14.98	QP		

*:Maximum data x:Over limit !:over margin

Operator:

Radiated Emission Measurement

File :DF-F7S

Data :#4

Date: 2009/07/04

Time: 16:11:32

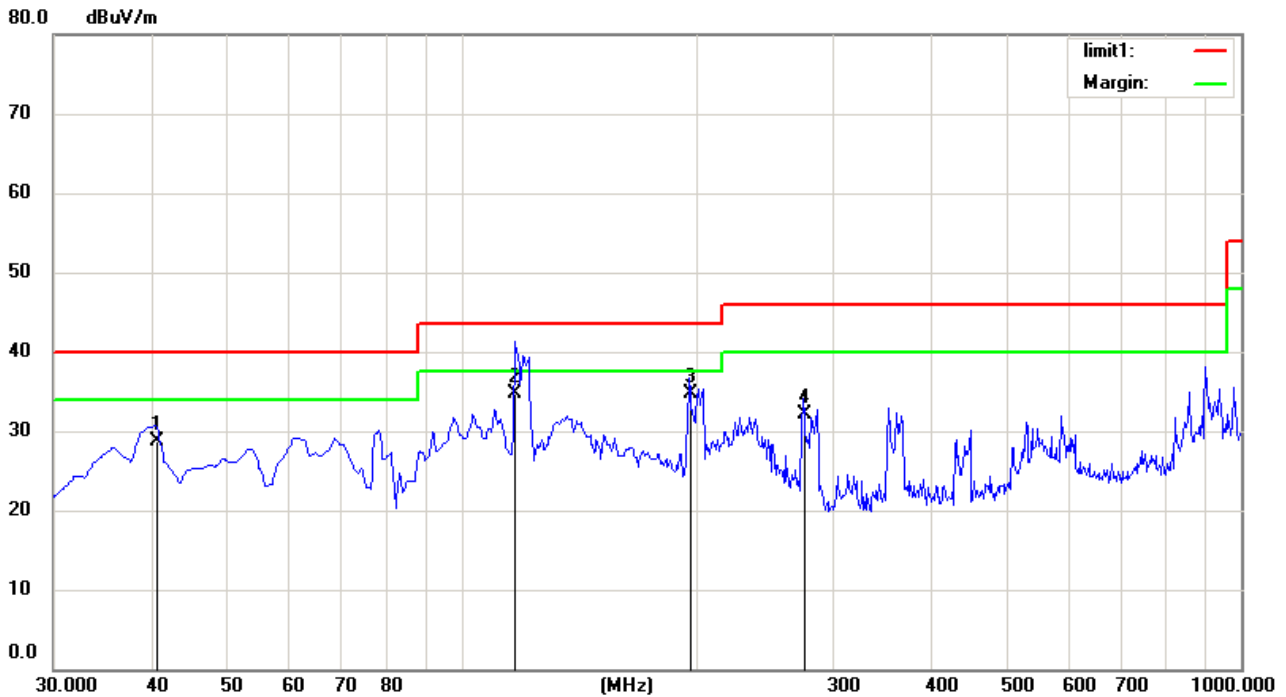

Site Chamber #1

Polarization: **Vertical**

Temperature: 26

Limit: (RE)FCC PART 15 class B 3m

Power: AC 120V/60Hz

Humidity: 55 %

EUT: 8 INCH DIGITAL PHOTO FRAME

M/N: DF-F8S

Mode: SD CARD PLAYING

Note: XKD-C2000IC5.0-12W

No.	Mk.	Freq. MHz	Reading Level dBuV	Correct Factor dB	Measure- ment dBuV/m	Limit dBuV/m	Over dB	Antenna Height cm	Table Degree	Detector	Comment
1		40.6700	42.83	-14.13	28.70	40.00	-11.30			QP	
2	*	117.3000	51.20	-16.49	34.71	43.50	-8.79			QP	
3		195.8700	48.74	-14.10	34.64	43.50	-8.86			QP	
4		274.4400	43.54	-11.50	32.04	46.00	-13.96			QP	

*:Maximum data x:Over limit !:over margin

Operator:

Radiated Emission Measurement

File :DF-F7S

Data :#5

Date: 2009/07/04

Time: 16:15:52

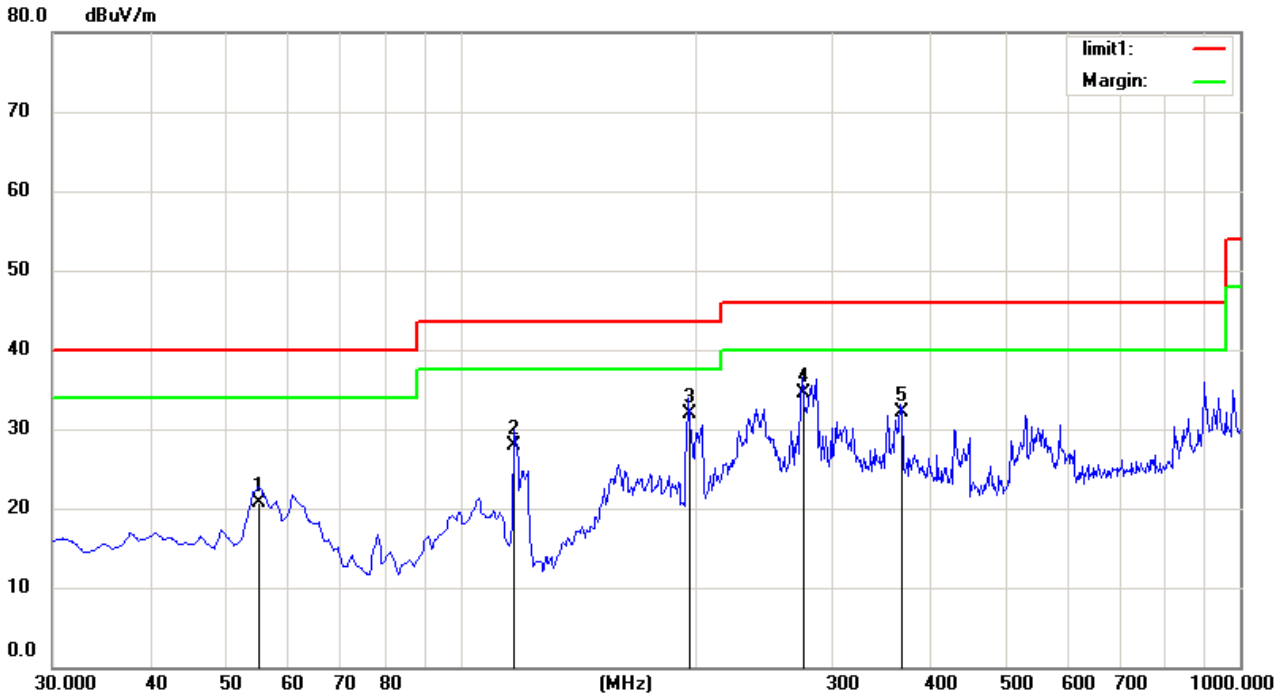

Site Chamber #1

Polarization: **Horizontal**

Temperature: 26

Limit: (RE)FCC PART 15 class B 3m

Power: AC 120V/60Hz

Humidity: 55 %

EUT: 8 INCH DIGITAL PHOTO FRAME

M/N: DF-F8S

Mode: USB PLAYING

Note: XKD-C2000IC5.0-12W

No.	Mk.	Freq. MHz	Reading Level dBuV	Correct Factor dB	Measure- ment dBuV/m	Limit dBuV/m	Over dB	Antenna Height cm	Table Degree degree	Comment
1		55.2200	35.39	-14.63	20.76	40.00	-19.24	QP		
2		117.3000	44.39	-16.49	27.90	43.50	-15.60	QP		
3		195.8700	46.01	-14.10	31.91	43.50	-11.59	QP		
4	*	274.4400	46.00	-11.50	34.50	46.00	-11.50	QP		
5		367.5600	41.57	-9.55	32.02	46.00	-13.98	QP		

*:Maximum data x:Over limit !:over margin

Operator:

Radiated Emission Measurement

File :DF-F7S

Data :#6

Date: 2009/07/04

Time: 16:22:42

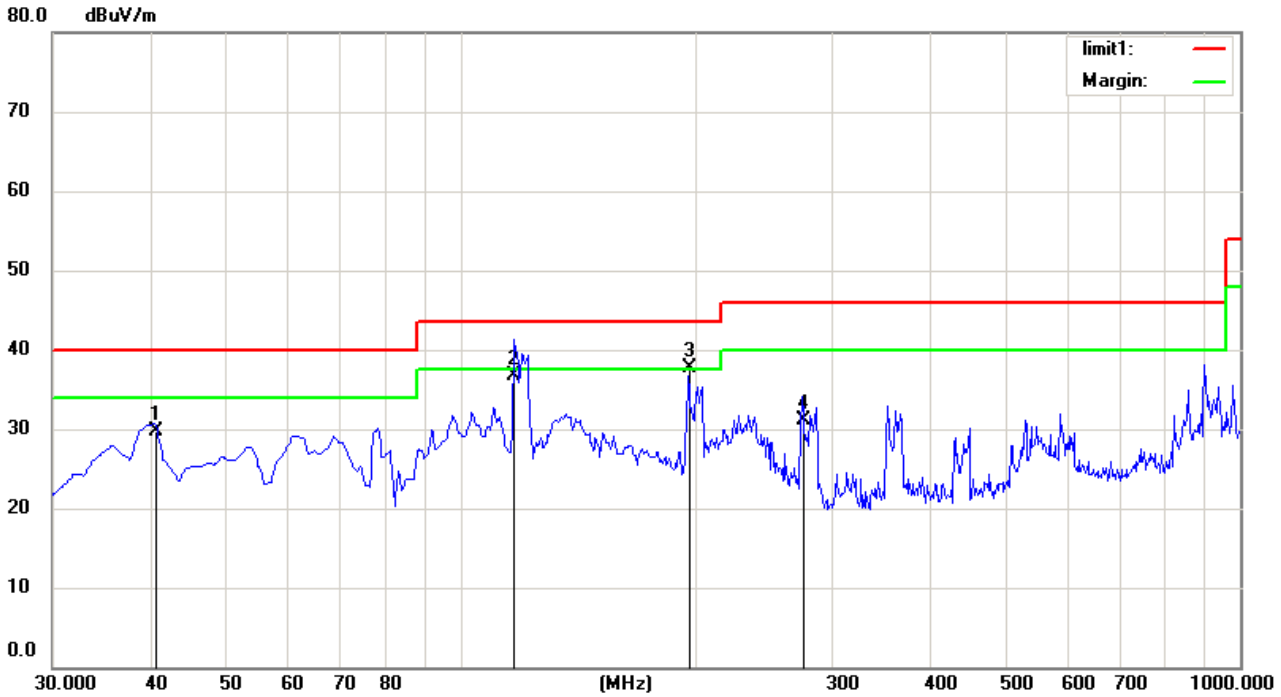

Site Chamber #1

Polarization: **Vertical**

Temperature: 26

Limit: (RE)FCC PART 15 class B 3m

Power: AC 120V/60Hz

Humidity: 55 %

EUT: 8 INCH DIGITAL PHOTO FRAME

M/N: DF-F8S

Mode: USB PLAYING

Note: XKD-C2000IC5.0-12W

No.	Mk.	Freq.	Reading Level	Correct Factor	Measurement	Limit	Over	Antenna Height	Table Degree	
		MHz	dBuV	dB	dBuV/m	dBuV/m	dB	Detector	cm	degree
1		40.6700	43.83	-14.13	29.70	40.00	-10.30	QP		
2		117.3000	53.20	-16.49	36.71	43.50	-6.79	QP		
3	*	195.8700	51.74	-14.10	37.64	43.50	-5.86	QP		
4		274.4400	42.54	-11.50	31.04	46.00	-14.96	QP		

*:Maximum data x:Over limit !:over margin

Operator:

Radiated Emission Measurement

File :DF-F7S

Data :#8

Date: 2009-7-6

Time: 11:12:10

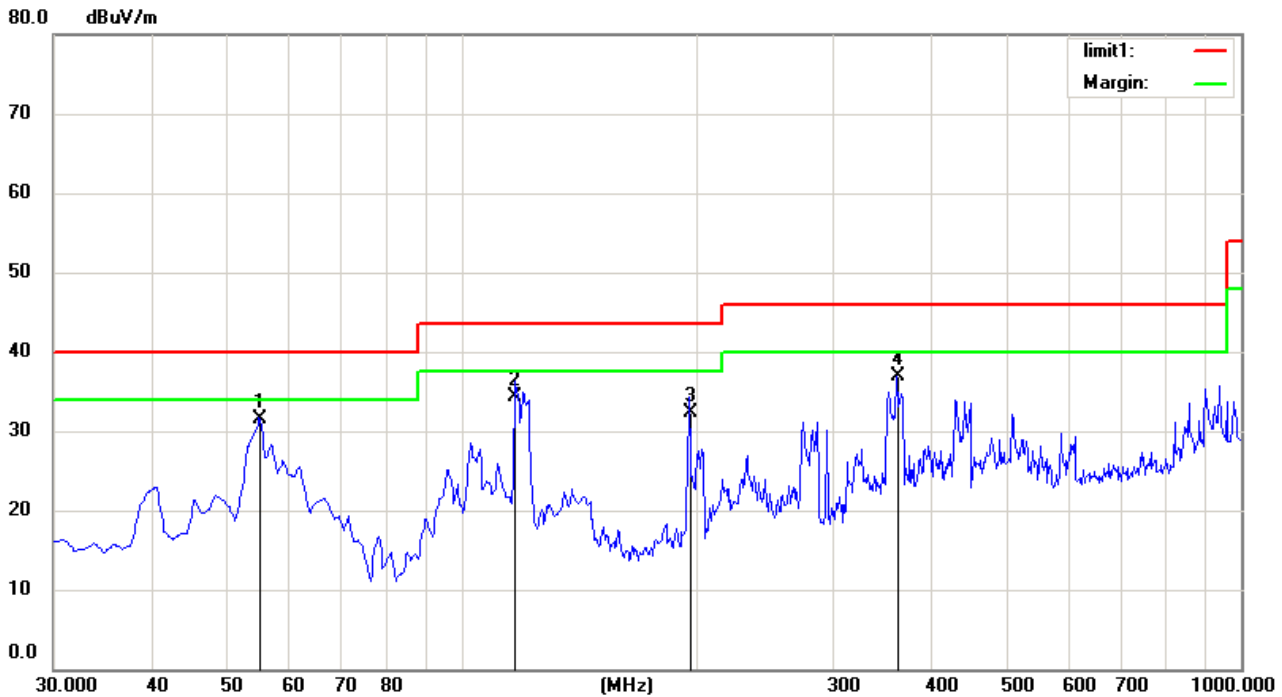

Site Chamber #1

Polarization: **Horizontal**

Temperature: 26

Limit: (RE)FCC PART 15 class B 3m

Power: AC 120V/60Hz

Humidity: 55 %

EUT: 8 INCH DIGITAL PHOTO FRAME

M/N: DF-F8S

Mode:CONNECT TO PC

Note: XKD-C2000IC5.0-12W

No.	Mk.	Freq.	Reading Level	Correct Factor	Measurement	Limit	Over	Antenna Height	Table Degree	
		MHz	dBuV	dB	dBuV/m	dBuV/m	dB	Detector	cm	degree
1	*	55.2200	46.23	-14.63	31.60	40.00	-8.40	QP		
2		117.3000	50.78	-16.49	34.29	43.50	-9.21	QP		
3		195.8700	46.41	-14.10	32.31	43.50	-11.19	QP		
4		362.7100	46.43	-9.59	36.84	46.00	-9.16	QP		

*:Maximum data x:Over limit !:over margin

Operator:

Radiated Emission Measurement

File :DF-F7S

Data :#9

Date: 2009-7-6

Time: 11:14:40

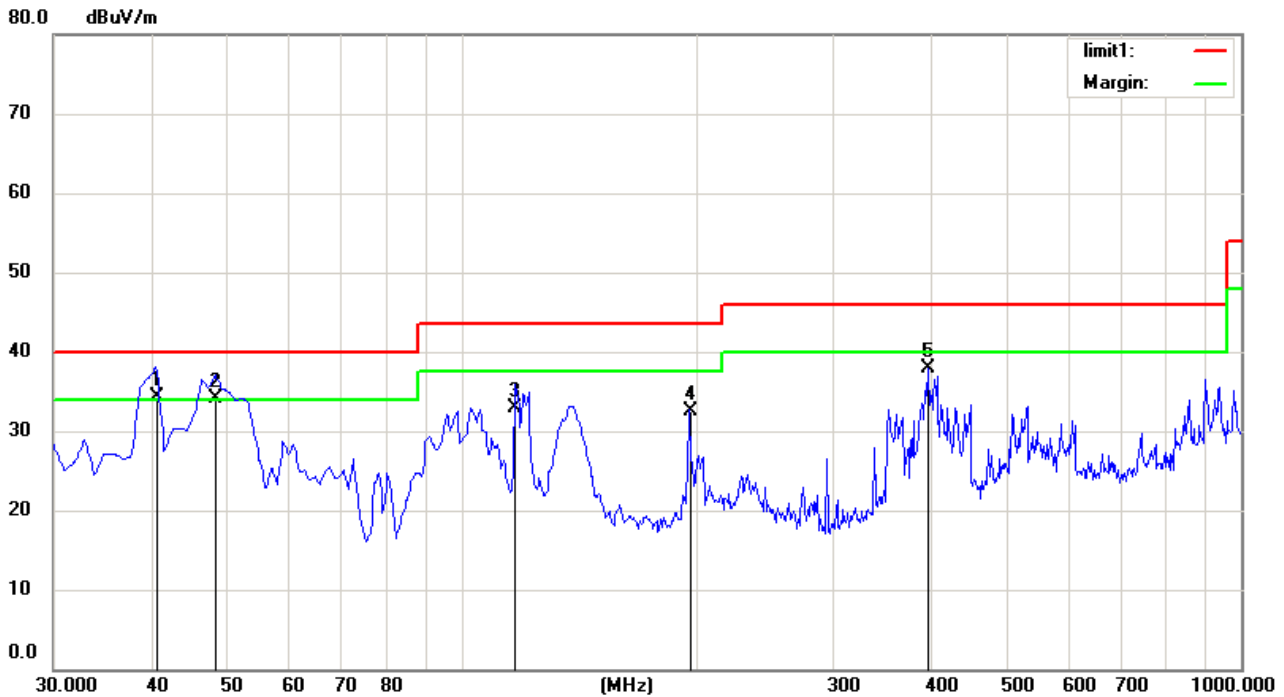

Site Chamber #1

Polarization: **Vertical**

Temperature: 26

Limit: (RE)FCC PART 15 class B 3m

Power: AC 120V/60Hz

Humidity: 55 %

EUT: 8 INCH DIGITAL PHOTO FRAME

M/N: DF-F8S

Mode:CONNECT TO PC

Note: XKD-C2000IC5.0-12W

No.	Mk.	Freq.	Reading Level	Correct Factor	Measurement	Limit	Over	Antenna Height	Table Degree	
		MHz	dBuV	dB	dBuV/m	dBuV/m	dB	Detector	cm	degree
1	*	40.6700	48.35	-14.13	34.22	40.00	-5.78	QP		
2	!	48.4300	48.33	-14.32	34.01	40.00	-5.99	QP		
3		117.3000	49.37	-16.49	32.88	43.50	-10.62	QP		
4		195.8700	46.70	-14.10	32.60	43.50	-10.90	QP		
5		397.6300	47.02	-9.03	37.99	46.00	-8.01	QP		

*:Maximum data x:Over limit !:over margin

Operator: