

FCC TEST REPORT

For

7 inch Digital Photo Frame

MODEL No.: DF07105-14-XXX(X=A-Z, a-z, 0-9)

Trademark: N/A

FCC ID: V37-6222-7DW

REPORT NO: KA09066047E

ISSUE DATE: July 07, 2009

Prepared for

WIN ACCORD LTD.

**12F, NO. 225, SEC 5, 105 SONG SHAN DIST.,
NAN JING EAST ROAD, TAIPEI, TAIWAN**

Prepared by

DONGGUAN EMTEK CO., LTD

**No. 281, Guantai Road, Nancheng District,
Dongguan, Guangdong, China**

TEL: +86-769-22807078

FAX: +86-769-22807079

TABLE OF CONTENTS

1. GENERAL INFORMATION.....	4
1.1 Description of Device (EUT).....	4
1.2. Description of Support Device	6
1.3 Test Facility	7
1.4 Measurement Uncertainty.....	7
2. POWER LINE CONDUCTED MEASUREMENT.....	8
2.1. Test Equipment.....	8
2.2. Block Diagram of Test Setup.....	8
2.3. Power Line Conducted Emission Measurement Limits.....	9
2.4. Configuration of EUT on Measurement	9
2.5. Operating Condition of EUT	9
2.6. Test Procedure	9
2.7. Power Line Conducted Emission Measurement Results	10
3. RADIATED EMISSION MEASUREMENT.....	38
3.1. Test Equipment.....	38
3.2. Block Diagram of Test Setup.....	39
3.3. Radiated Emission Limit	39
3.4. EUT Configuration on Measurement	40
3.5. Operating Condition of EUT	40
3.6. Test Procedure	40
3.7. Radiated Emission Noise Measurement Results.....	40

TEST REPORT DESCRIPTION

Applicant : WIN ACCORD LTD.
Manufacturer : WIN ACCORD LTD.
EUT : 7 inch Digital Photo Frame
FCC ID No. : V37-6222-7DW
Test Voltage : 120V/60Hz
File Number : KA09066047E
Date of Test : July 01, 2009 to July 06, 2009

Measurement Procedure Used:

FCC Rules and Regulations Part 15 Subpart B Class B July 2008 & FCC / ANSI C63.4-2003

The device described above is tested by Dongguan EMTEK Co., Ltd. to determine the maximum emission levels emanating from the device. The maximum emission levels are compared to the FCC Part 15 Subpart Class B limits both radiated and conducted emissions. The measurement results are contained in this test report and Dongguan EMTEK Co., Ltd. is assumed full responsibility for the accuracy and completeness of these measurements. Also, this report shows that the Equipment Under Test (EUT) is to be technically compliant with the FCC requirements.

This report applies to above tested sample only. This report shall not be reproduced in part without written approval of Dongguan EMTEK Co., Ltd.

Approved By



Nicol Lee / Q.A. Manager
DONGGUAN EMTEK CO., LTD.

1. GENERAL INFORMATION

1.1. Description of Device (EUT)

EUT : 7 inch Digital Photo Frame

Model Number : Basic Model: DF07105-14-XXX, (X=A-Z, a-z, 0-9)
Additional Model: DMF070WB, DF-F7S, BS07W.

(Note: Those models are the same except appearance and model names, all models use the same FCC ID Number.)

Cable : USB Line, 1.5m shielded line, with a core.

FCC ID Number : V37-6222-7DW

Trade Mark : N/A

Power Supply : 100~240V 50/60Hz

ADAPTER 1 : Manufacturer: HONOR ELECTRONIC CO., LTD.
M/N: ADS-12G-0605010GPCU
Input: AC 100~240V 50/60Hz
Output: DC 5V 2.0A
Output line: Unshielded line (with a core)

ADAPTER 2 : Manufacturer: E-TEK Electronics Manufactory Ltd.
M/N: ZDA050200US
Input: AC 100~240V 50/60Hz
Output: DC 5V 2.0A
Output line: Unshielded line (with a core)

ADAPTER 3 : Manufacturer: MOSO
M/N: XKD-C2000IC5.0-12W
Input: AC 100~240V 50/60Hz
Output: DC 5V 2.0A
Output line: Unshielded line (with a core)

Remark : They are different model name and appearance.

Applicant : WIN ACCORD LTD.

Address : 12F, NO. 225, SEC 5, 105 SONG SHAN DIST., NAN JING EAST ROAD, TAIPEI, TAIWAN

Manufacturer : WIN ACCORD LTD.

Address : 12F, NO. 225, SEC 5, 105 SONG SHAN DIST., NAN JING EAST ROAD, TAIPEI, TAIWAN

Date of sample : July 01, 2009

Date of Test : July 01, 2009 to July 06, 2009

1.2. Description of Support Device

PC	:	Manufacturer: Dell Inc. M/N: DCSM S/N: CXBMMZX FCC ID: DoC
LCD Monitor	:	Manufacturer: Dell Inc. M/N: E1909Wf FCC ID: DoC
USB Mouse	:	Manufacturer: Dell Inc. M/N: M-UAK DEL7 P/N: XN966 FCC ID: DoC
USB Keyboard	:	Manufacturer: Dell Inc. M/N: L30U S/N:D1C FCC ID: DoC
Printer	:	Manufacturer: HP M/N:HP LaserJet 1020 S/N: CNCK512065 P/N: Q5911A FCC ID: DoC
USB	:	Kingston 2GB
SD Card	:	Kingston 2GB

1.3 Test Facility

Site Description

EMC Lab. : Accredited by CNAS, 2007.07.27
The certificate is valid until 2012.07.26
The Laboratory has been assessed and proved to be in compliance with CNAS/CL01:2005
The Certificate Registration Number is L3150

Accredited by TUV Rheinland Shenzhen 2008.5
The certificate is valid until 2009.12
The Laboratory has been assessed according to the requirements ISO/IEC 17025

Accredited by FCC, Nov. 05, 2008
The Certificate Number is 247565.

Accredited by Industry Canada, May 24, 2008
The Certificate Registration Number. is 46405-4480

Name of Firm : Dongguan EMTEK Co., Ltd.
Site Location : No.281, Guantai Road, Nancheng District, Dongguan, Guangdong, China.

1.4 Measurement Uncertainty

Conducted Emission Uncertainty : $U_r = 3.3$

Radiated Emission Uncertainty : $U_c = 2.8$

Disturbance Power Uncertainty : $U_c = 2.6$

2. POWER LINE CONDUCTED MEASUREMENT

2.1. Test Equipment

The following test equipments are used during the power line conducted measurement:

Item	Equipment	Manufacturer	Model No.	Serial No.	Last Cal.	Cal. Interval
1	EMI Test Receiver	ROHDE&SCHWARZ	ESCS30	828985/018	May 29, 2009	1 Year
2	LISN	ROHDE&SCHWARZ	ENV216	100017	May 29, 2009	1Year
3	Conical Housing	EMTEK	N/A	N/A	May 29, 2009	N/A
4	Voltage Probe	SCHWARZBECK	EZ-17	100213	May 29, 2008	1Year
5	50 Ω Coaxial Switch	ANRITSU CORP	MP59B	6100175589	May 29, 2009	1Year

2.2. Block Diagram of Test Setup

2.2.1 Block diagram of connection between the EUT and simulators

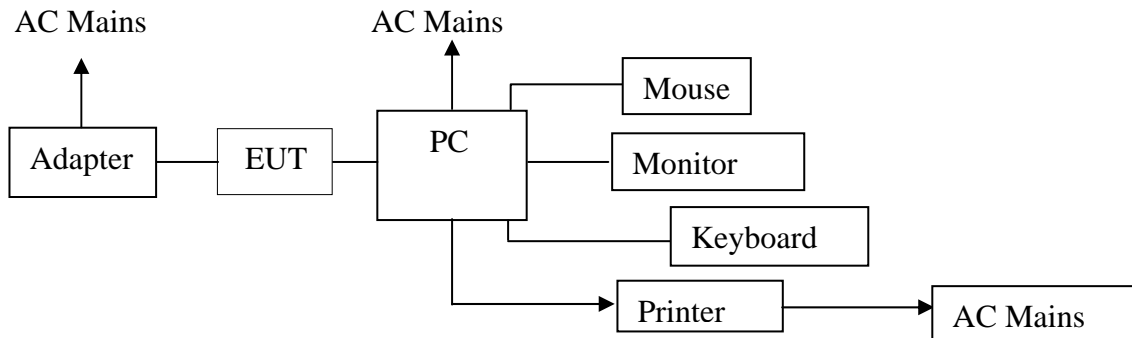

(EUT: 7 inch Digital Photo Frame)

2.2.2 Block diagram of test setup

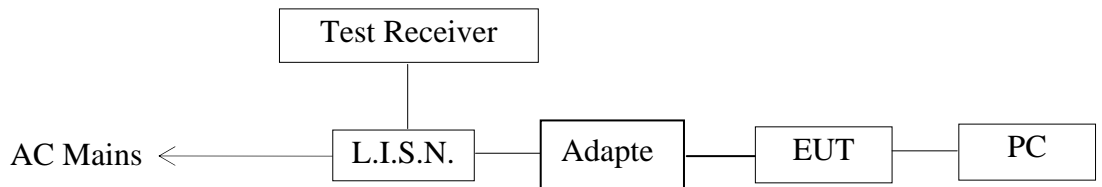

(EUT: 7 inch Digital Photo Frame)

2.3. Power Line Conducted Emission Measurement Limits

Conducted Emission Limits is as following.

Frequency MHz	Limits dB(μ V)	
	Quasi-peak Level	Average Level
0.15 ~ 0.50	66 ~ 56*	56 ~ 46*
0.50 ~ 5.00	56	46
5.00 ~ 30.00	60	50

- Notes: 1. *Decreasing linearly with logarithm of frequency.
2. The lower limit shall apply at the transition frequencies.

2.4. Configuration of EUT on Measurement

The following equipments are installed on Power Line Conducted Emission Measurement to meet the commission requirement and operating regulations in a manner which tends to maximize its emission characteristics in a normal application.

EUT : 7 inch Digital Photo Frame
Model Number : DF-F7S
Manufacturer : WIN ACCORD LTD.

2.5. Operating Condition of EUT

- 2.5.1. Setup the EUT and simulator as shown as Section 2.2.
- 2.5.2. Turn on the power of all equipment.
- 2.5.3. Let the EUT work in test model (Memorying, SD Card Playing, USB Playing, Connect to PC) and measure it.

2.6. Test Procedure

The EUT system is connected to the power mains through a line impedance stabilization network (L.I.S.N.). This provides a 50ohm coupling impedance for the EUT system. Please refer the block diagram of the test setup and photographs. Both sides of AC line are checked to find out the maximum conducted emission. In order to find the maximum emission levels, the relative positions of equipment and all of the interface cables shall be changed according to FCC ANSI C63.4-2003 on Conducted Emission Measurement.

The bandwidth of test receiver (R&S ESCS30) is set at 9KHz.
The frequency range from 150KHz to 30MHz is checked.

2.7. Power Line Conducted Emission Measurement Results

PASS

The frequency range from 150KHz to 30 MHz is investigated.

The scanning waveforms refer to the following pages.

Adapter ADS-12G-0605010GPCU used for test.

Conducted Emission Measurement

File :DF-F7S
 80.0 dBuV

Data :#13

Date: 2009-7-4

Time: 15:37:40

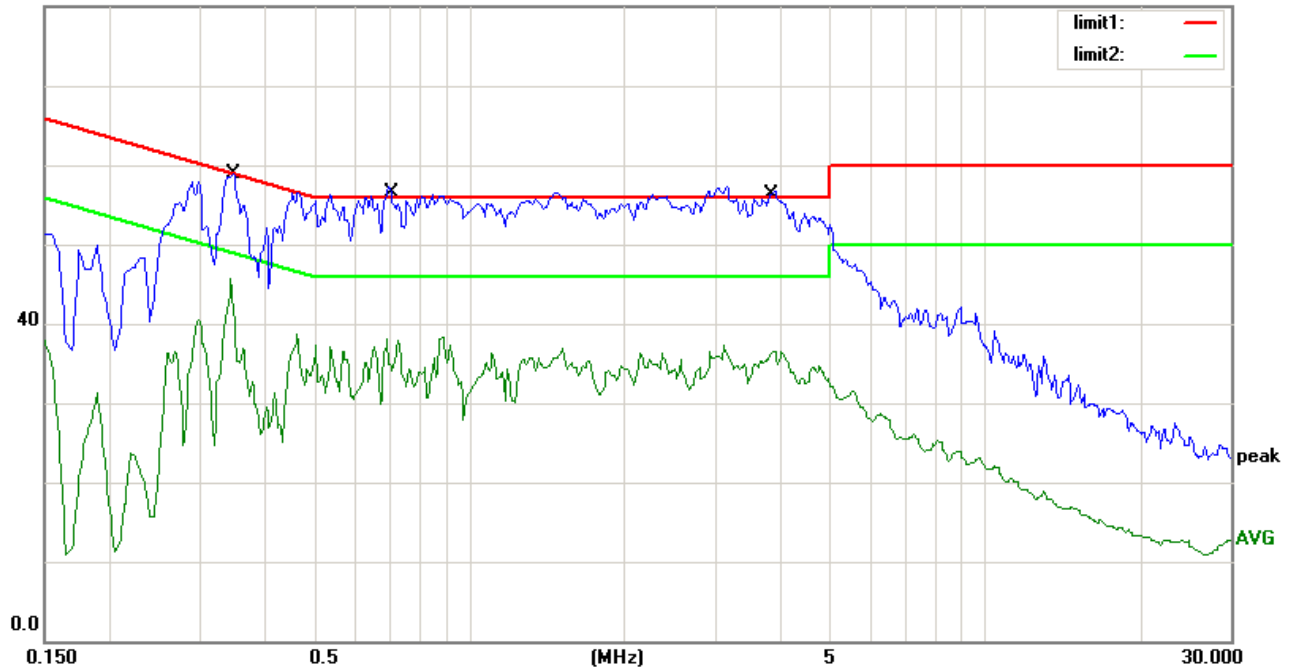

Site site #1

Phase: **N**

Temperature: 25

Limit: (CE)FCC PART 15 class B_QP

Power: AC 120V/60Hz

Humidity: 50 %

EUT: 7 INCH DIGITAL PHOTO FRAME

M/N: DF-F7S

Mode: CONNECT TO PC

Note: ADS-12G-0605010GPCU

No.	Mk.	Freq. MHz	Reading Level dBuV	Correct Factor dB	Measure- ment dBuV	Limit dBuV	Over dB	Detector	Comment
1	*	0.3465	54.00	0.00	54.00	59.05	-5.05	QP	
2		0.3465	43.50	0.00	43.50	49.05	-5.55	AVG	
3		0.7122	48.40	0.00	48.40	56.00	-7.60	QP	
4		0.7122	34.00	0.00	34.00	46.00	-12.00	AVG	
5		3.7994	50.30	0.00	50.30	56.00	-5.70	QP	
6		3.7994	35.00	0.00	35.00	46.00	-11.00	AVG	

*:Maximum data x:Over limit !:over margin Comment: Factor build in receiver. Operator:

Conducted Emission Measurement

File :DF-F7S
 80.0 dBuV

Data :#14

Date: 2009-7-4

Time: 15:41:39

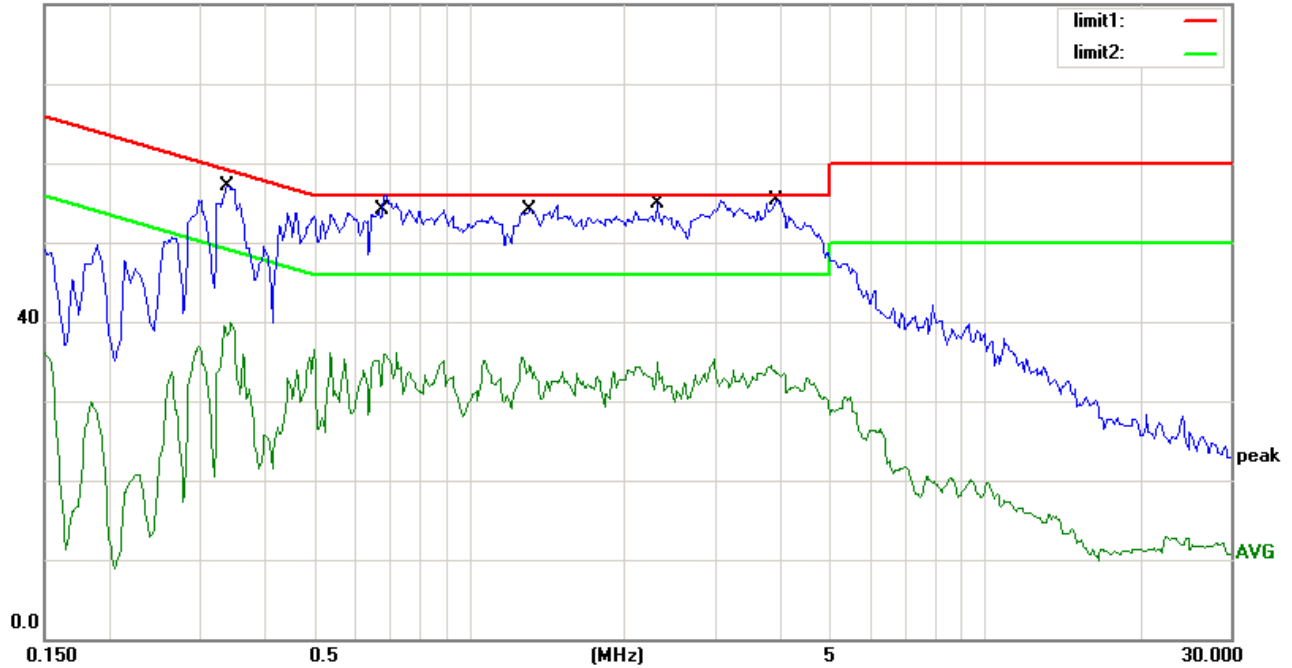

Site site #1

Phase: **L1**

Temperature: 25

Limit: (CE)FCC PART 15 class B_QP

Power: AC 120V/60Hz

Humidity: 50 %

EUT: 7 INCH DIGITAL PHOTO FRAME

M/N: DF-F7S

Mode: CONNECT TO PC

Note: ADS-12G-0605010GPCU

No.	Mk.	Freq. MHz	Reading Level dBuV	Correct Factor dB	Measure- ment dBuV	Limit dBuV	Over dB	Detector	Comment
1		0.3400	53.45	0.00	53.45	59.20	-5.75	QP	
2		0.3400	39.90	0.00	39.90	49.20	-9.30	AVG	
3		0.6700	49.37	0.00	49.37	56.00	-6.63	QP	
4		0.6700	35.86	0.00	35.86	46.00	-10.14	AVG	
5		1.3150	50.12	0.00	50.12	56.00	-5.88	QP	
6		1.3150	35.57	0.00	35.57	46.00	-10.43	AVG	
7		2.3200	50.39	0.00	50.39	56.00	-5.61	QP	
8		2.3200	35.00	0.00	35.00	46.00	-11.00	AVG	
9	*	3.9600	51.03	0.00	51.03	56.00	-4.97	QP	
10		3.9600	34.43	0.00	34.43	46.00	-11.57	AVG	

*:Maximum data x:Over limit !:over margin Comment: Factor build in receiver. Operator:

Conducted Emission Measurement

File :DF-F7S
 80.0 dBuV

Data :#15

Date: 2009-7-4

Time: 15:46:07

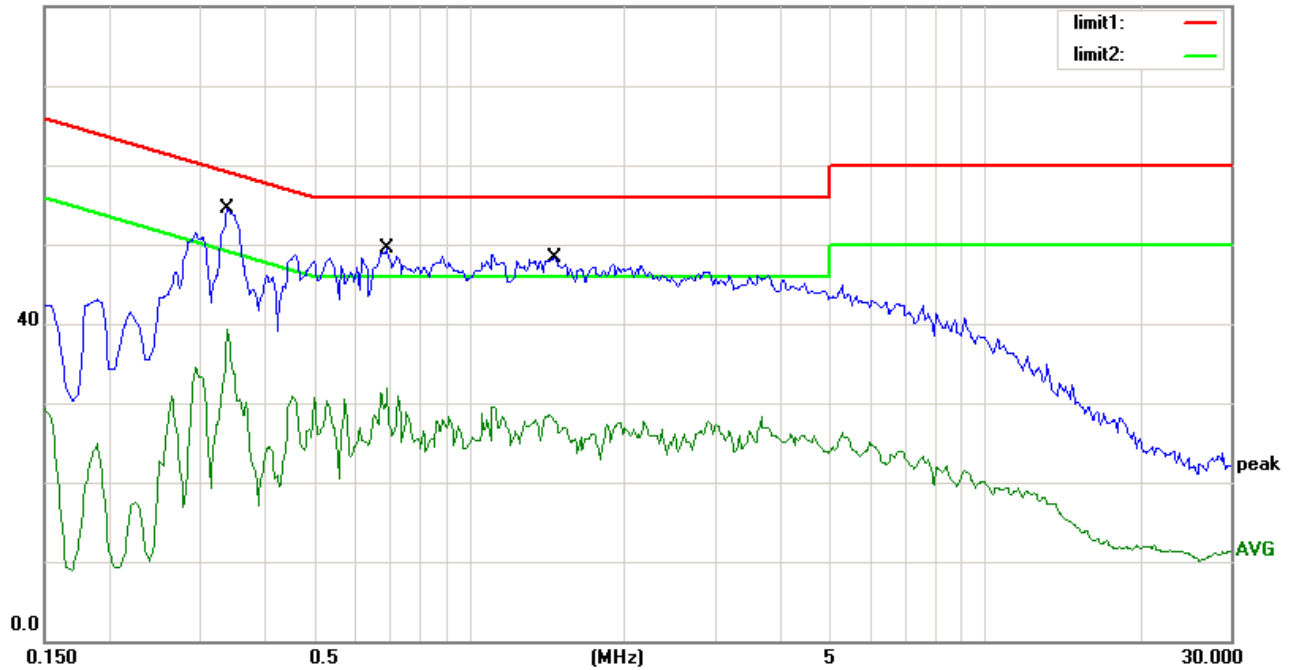

Site site #1

Phase: **L1**

Temperature: 25

Limit: (CE)FCC PART 15 class B_QP

Power: AC 120V/60Hz

Humidity: 50 %

EUT: 7 INCH DIGITAL PHOTO FRAME

M/N: DF-F7S

Mode: Memorying

Note: ADS-12G-0605010GPCU

No.	Mk.	Freq. MHz	Reading Level dBuV	Correct Factor dB	Measure- ment dBuV	Limit dBuV	Over dB	Detector	Comment
1	*	0.3400	51.40	0.00	51.40	59.20	-7.80	QP	
2		0.3400	36.40	0.00	36.40	49.20	-12.80	AVG	
3		0.7010	45.50	0.00	45.50	56.00	-10.50	QP	
4		0.7010	29.70	0.00	29.70	46.00	-16.30	AVG	
5		1.4562	43.20	0.00	43.20	56.00	-12.80	QP	
6		1.4562	27.00	0.00	27.00	46.00	-19.00	AVG	

Conducted Emission Measurement

File :DF-F7S
 80.0 dBuV

Data :#16

Date: 2009-7-4

Time: 15:50:21

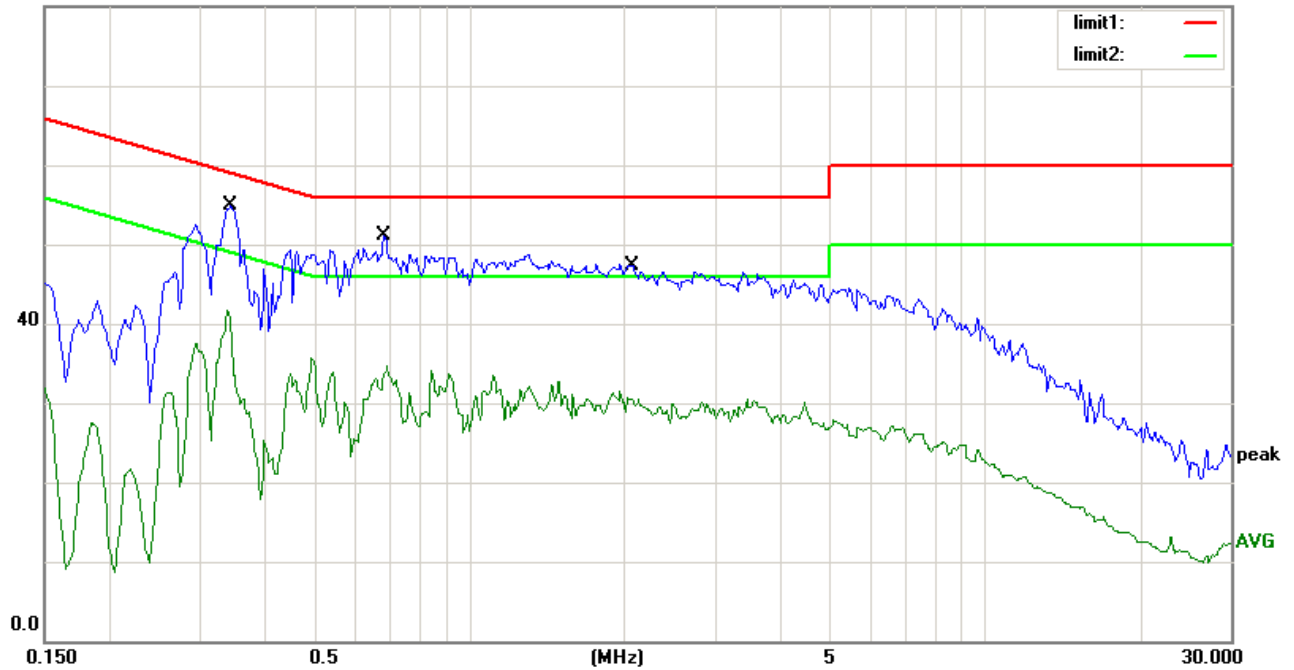

Site site #1

Phase: **N**

Temperature: 25

Limit: (CE)FCC PART 15 class B_QP

Power: AC 120V/60Hz

Humidity: 50 %

EUT: 7 INCH DIGITAL PHOTO FRAME

M/N: DF-F7S

Mode: Memorying

Note: ADS-12G-0605010GPCU

No.	Mk.	Freq. MHz	Reading Level dBuV	Correct Factor dB	Measure- ment dBuV	Limit dBuV	Over dB	Detector	Comment
1	*	0.3450	52.50	0.00	52.50	59.08	-6.58	QP	
2		0.3450	39.80	0.00	39.80	49.08	-9.28	AVG	
3		0.6850	46.60	0.00	46.60	56.00	-9.40	QP	
4		0.6850	34.40	0.00	34.40	46.00	-11.60	AVG	
5		2.0441	42.30	0.00	42.30	56.00	-13.70	QP	
6		2.0441	29.50	0.00	29.50	46.00	-16.50	AVG	

*:Maximum data x:Over limit !:over margin Comment: Factor build in receiver. Operator:

Conducted Emission Measurement

File :DF-F7S
 80.0 dBuV

Data :#18

Date: 09/07/4/

Time: 16/04/28

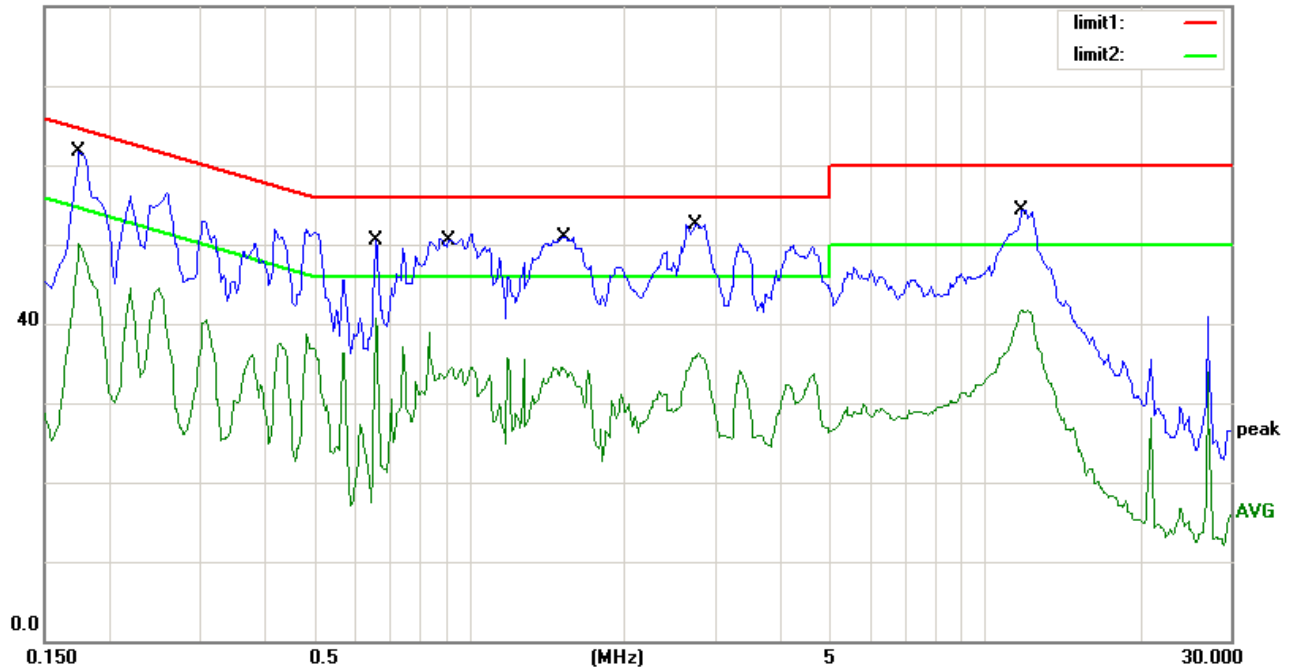

Site site #1

Phase: **L1**

Temperature: 25

Limit: (CE)FCC PART 15 class B_QP

Power: AC 120V/60Hz

Humidity: 50 %

EUT: 7 INCH DIGITAL PHOTO FRAME

M/N: DF-F7S

Mode: SD CARD PLAYING

Note: ADS-12G-0605010GPCU

No.	Mk.	Freq. MHz	Reading Level dBuV	Correct Factor dB	Measure- ment dBuV	Limit dBuV	Over dB	Detector	Comment
1		0.1750	58.60	0.00	58.60	64.72	-6.12	QP	
2	*	0.1750	49.50	0.00	49.50	54.72	-5.22	AVG	
3		0.6600	47.80	0.00	47.80	56.00	-8.20	QP	
4		0.6600	40.30	0.00	40.30	46.00	-5.70	AVG	
5		0.9100	45.20	0.00	45.20	56.00	-10.80	QP	
6		0.9100	32.60	0.00	32.60	46.00	-13.40	AVG	
7		1.5300	45.80	0.00	45.80	56.00	-10.20	QP	
8		1.5300	34.40	0.00	34.40	46.00	-11.60	AVG	
9		2.7400	47.50	0.00	47.50	56.00	-8.50	QP	
10		2.7400	36.00	0.00	36.00	46.00	-10.00	AVG	
11		11.8000	48.20	0.00	48.20	60.00	-11.80	QP	
12		11.8000	40.90	0.00	40.90	50.00	-9.10	AVG	

*:Maximum data x:Over limit !:over margin Comment: Factor build in receiver. Operator:

Conducted Emission Measurement

File :DF-F7S
 80.0 dBuV

Data :#20

Date: 2009/07/4

Time: 16:15:07

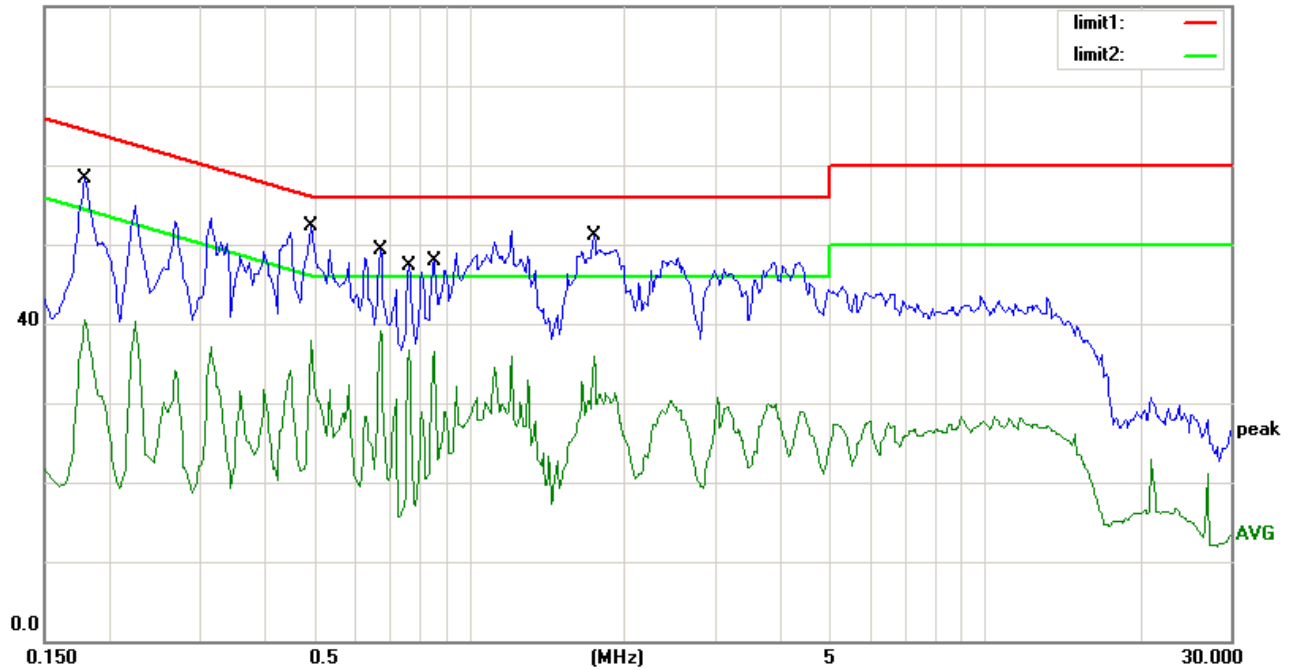

Site site #1

Phase: **N**

Temperature: 25

Limit: (CE)FCC PART 15 class B_QP

Power: AC 120V/60Hz

Humidity: 50 %

EUT: 7 INCH DIGITAL PHOTO FRAME

M/N: DF-F7S

Mode: SD CARD PLAYING

Note: ADS-12G-0605010GPCU

No.	Mk.	Freq. MHz	Reading Level dBuV	Correct Factor dB	Measure- ment dBuV	Limit dBuV	Over dB	Detector	Comment
1	*	0.1800	55.40	0.00	55.40	64.49	-9.09	QP	
2		0.1800	40.40	0.00	40.40	54.49	-14.09	AVG	
3		0.4950	43.50	0.00	43.50	56.08	-12.58	QP	
4		0.4950	31.10	0.00	31.10	46.08	-14.98	AVG	
5		0.6750	35.70	0.00	35.70	56.00	-20.30	QP	
6		0.6750	22.20	0.00	22.20	46.00	-23.80	AVG	
7		0.7650	33.80	0.00	33.80	56.00	-22.20	QP	
8		0.7650	19.50	0.00	19.50	46.00	-26.50	AVG	
9		0.8550	37.70	0.00	37.70	56.00	-18.30	QP	
10		0.8550	22.60	0.00	22.60	46.00	-23.40	AVG	
11		1.7450	44.30	0.00	44.30	56.00	-11.70	QP	
12		1.7450	30.80	0.00	30.80	46.00	-15.20	AVG	

*:Maximum data x:Over limit !:over margin Comment: Factor build in receiver. Operator:

Conducted Emission Measurement

File :DF-F7S
 80.0 dBuV

Data :#41

Date: 09/07/06/

Time: 13/50/42

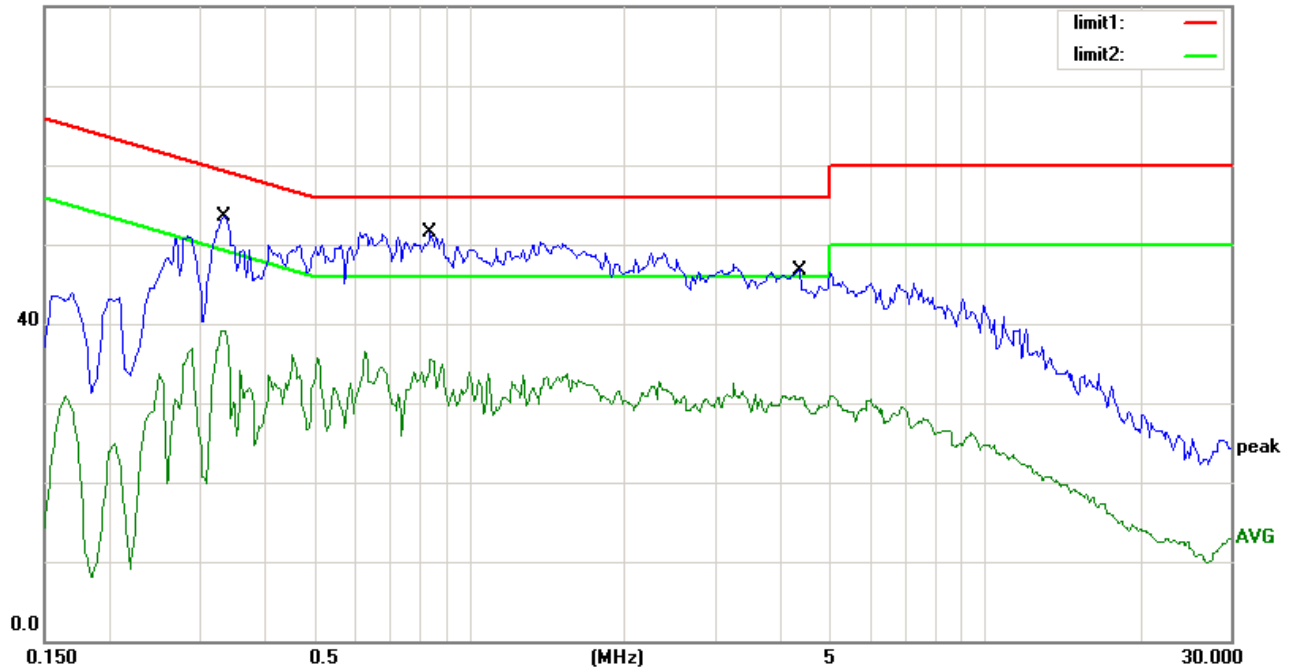

Site site #1

Limit: (CE)FCC PART 15 class B_QP
 EUT: 7 INCH DIGITAL PHOTO FRAME
 M/N: DF-F7S
 Mode: USB PLAYING
 Note: ADS-12G-0605010GPCU

Phase: **N**

Power: AC 120V/60Hz

Temperature: 25

Humidity: 50 %

No.	Mk.	Freq. MHz	Reading Level dBuV	Correct Factor dB	Measure- ment dBuV	Limit dBuV	Over dB	Detector	Comment
1	*	0.3373	49.90	0.00	49.90	59.27	-9.37	QP	
2		0.3373	35.70	0.00	35.70	49.27	-13.57	AVG	
3		0.8438	46.40	0.00	46.40	56.00	-9.60	QP	
4		0.8438	33.90	0.00	33.90	46.00	-12.10	AVG	
5		4.3146	39.60	0.00	39.60	56.00	-16.40	QP	
6		4.3146	28.30	0.00	28.30	46.00	-17.70	AVG	

*:Maximum data x:Over limit !:over margin Comment: Factor build in receiver. Operator:

Conducted Emission Measurement

File :DF-F7S
 80.0 dBuV

Data :#42

Date: 09/07/06/

Time: 13/54/35

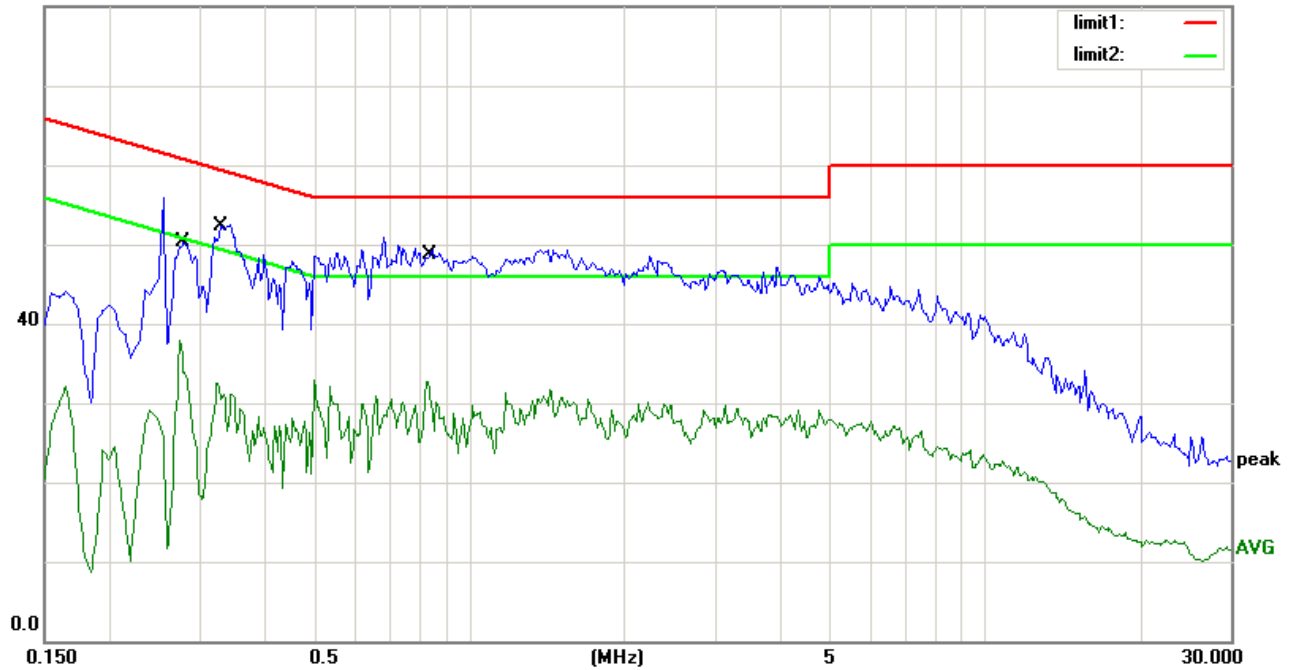

Site site #1

Phase: **L1**

Temperature: 25

Limit: (CE)FCC PART 15 class B_QP

Power: AC 120V/60Hz

Humidity: 50 %

EUT: 7 INCH DIGITAL PHOTO FRAME

M/N: DF-F7S

Mode: USB PLAYING

Note: ADS-12G-0605010GPCU

No.	Mk.	Freq.	Reading Level	Correct Factor	Measurement	Limit	Over	Detector	Comment
		MHz	dBuV	dB	dBuV	dBuV	dB		
1		0.2750	47.50	0.00	47.50	60.97	-13.47	QP	
2		0.2750	33.40	0.00	33.40	50.97	-17.57	AVG	
3	*	0.3303	50.30	0.00	50.30	59.44	-9.14	QP	
4		0.3303	35.80	0.00	35.80	49.44	-13.64	AVG	
5		0.8300	45.60	0.00	45.60	56.00	-10.40	QP	
6		0.8300	29.40	0.00	29.40	46.00	-16.60	AVG	

*:Maximum data x:Over limit !:over margin Comment: Factor build in receiver. Operator:

Adapter **ZDA050200US** used for test.

Conducted Emission Measurement

File :DF-F7S
 80.0 dBuV

Data :#29

Date: 09/07/06/

Time: 10/14/00

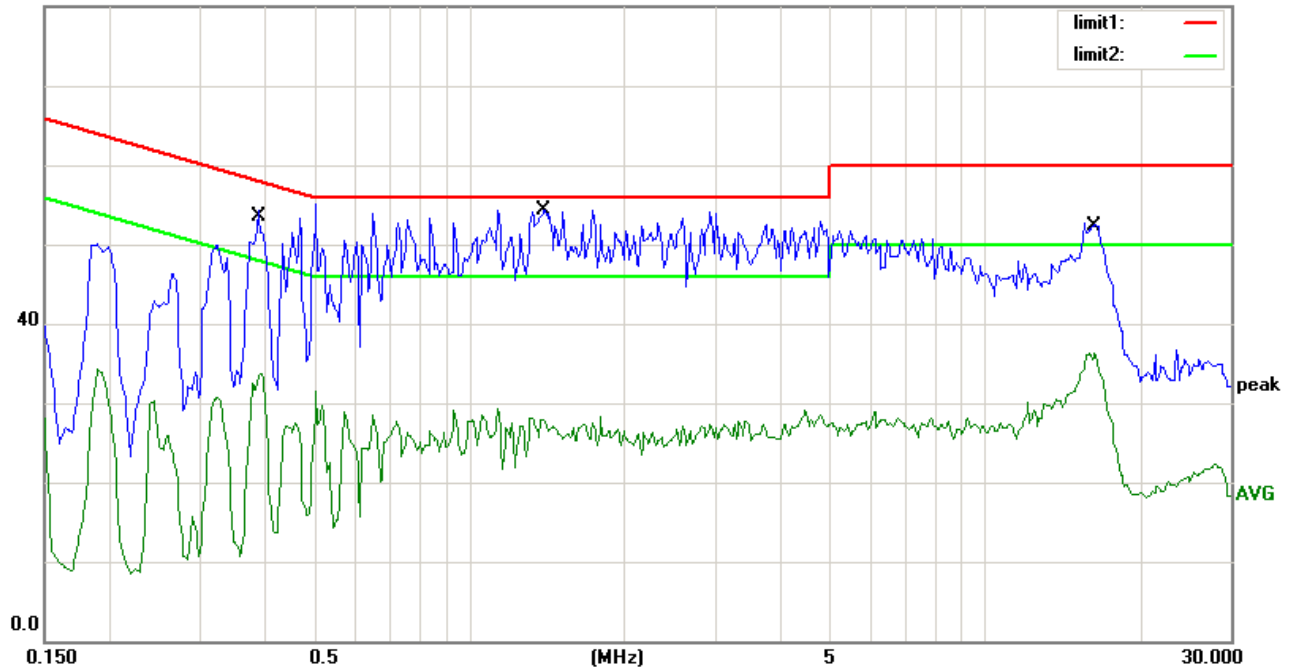

Site site #1

Phase: **L1**

Temperature: 25

Limit: (CE)FCC PART 15 class B_QP

Power: AC 120V/60Hz

Humidity: 50 %

EUT: 7 INCH DIGITAL PHOTO FRAME

M/N: DF-F7S

Mode: SD CARD PLAYING

Note: ZDA050200US

No.	Mk.	Freq. MHz	Reading Level dBuV	Correct Factor dB	Measure- ment dBuV	Limit dBuV	Over dB	Detector	Comment
1	*	0.3950	47.60	0.00	47.60	57.96	-10.36	QP	
2		0.3950	32.80	0.00	32.80	47.96	-15.16	AVG	
3		1.4032	43.50	0.00	43.50	56.00	-12.50	QP	
4		1.4032	27.00	0.00	27.00	46.00	-19.00	AVG	
5		16.0545	45.40	0.00	45.40	60.00	-14.60	QP	
6		16.0545	34.30	0.00	34.30	50.00	-15.70	AVG	

*:Maximum data x:Over limit !:over margin Comment: Factor build in receiver. Operator:

Conducted Emission Measurement

File :DF-F7S
 80.0 dBuV

Data :#30

Date: 09/07/06/

Time: 10/21/41

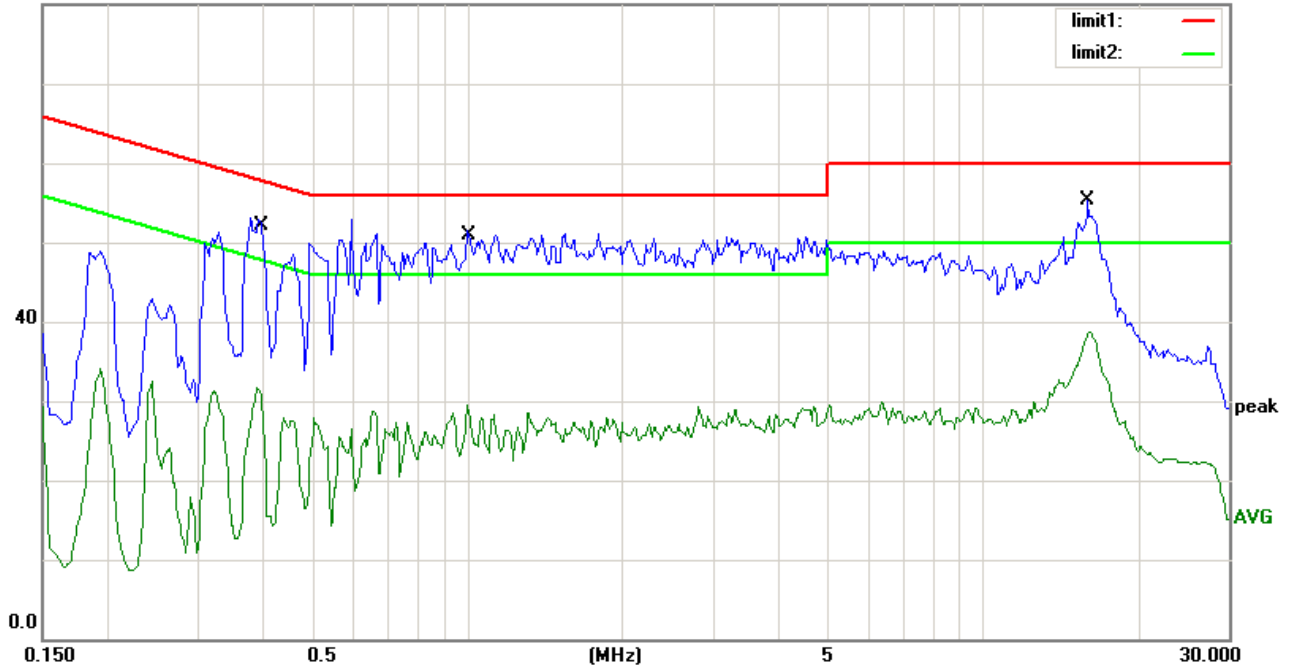

Site site #1

Phase: **N**

Temperature: 25

Limit: (CE)FCC PART 15 class B_QP

Power: AC 120V/60Hz

Humidity: 50 %

EUT: 7 INCH DIGITAL PHOTO FRAME

M/N: DF-F7S

Mode: SD CARD PLAYING

Note: ZDA050200US

No.	Mk.	Freq. MHz	Reading Level dBuV	Correct Factor dB	Measure- ment dBuV	Limit dBuV	Over dB	Detector	Comment
1	*	0.4020	48.00	0.00	48.00	57.81	-9.81	QP	
2		0.4020	30.00	0.00	30.00	47.81	-17.81	AVG	
3		1.0157	43.40	0.00	43.40	56.00	-12.60	QP	
4		1.0157	25.50	0.00	25.50	46.00	-20.50	AVG	
5		15.9750	46.80	0.00	46.80	60.00	-13.20	QP	
6		15.9750	37.50	0.00	37.50	50.00	-12.50	AVG	

Conducted Emission Measurement

File :DF-F7S
 80.0 dBuV

Data :#32

Date: 09/07/06/

Time: 10/48/00

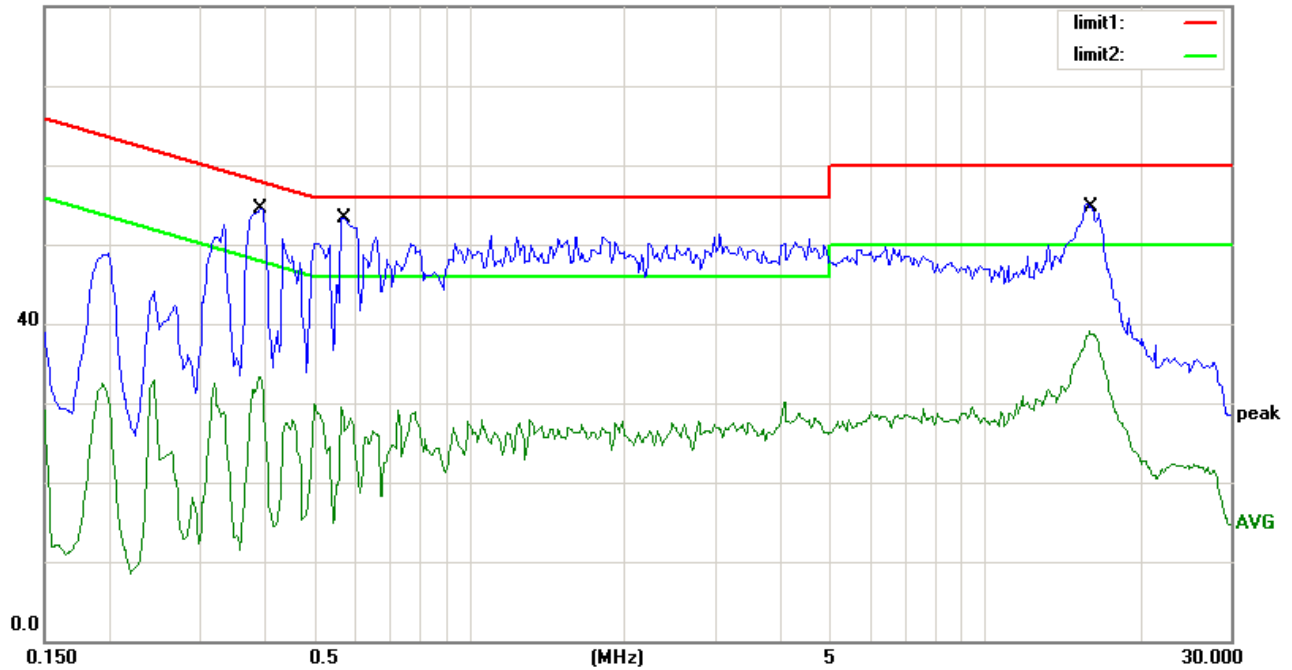

Site site #1

Phase: **N**

Temperature: 25

Limit: (CE)FCC PART 15 class B_QP

Power: AC 120V/60Hz

Humidity: 50 %

EUT: 7 INCH DIGITAL PHOTO FRAME

M/N: DF-F7S

Mode: USB PLAYING

Note: ZDA050200US

No.	Mk.	Freq. MHz	Reading Level dBuV	Correct Factor dB	Measure- ment dBuV	Limit dBuV	Over dB	Detector	Comment
1		0.3950	51.43	0.00	51.43	57.96	-6.53	QP	
2		0.3950	33.22	0.00	33.22	47.96	-14.74	AVG	
3	*	0.5750	50.16	0.00	50.16	56.00	-5.84	QP	
4		0.5750	26.59	0.00	26.59	46.00	-19.41	AVG	
5		16.1400	50.53	0.00	50.53	60.00	-9.47	QP	
6		16.1400	38.75	0.00	38.75	50.00	-11.25	AVG	

*:Maximum data x:Over limit !:over margin Comment: Factor build in receiver. Operator:

Conducted Emission Measurement

File :DF-F7S
 80.0 dBuV

Data :#33

Date: 09/07/06/

Time: 10/55/00

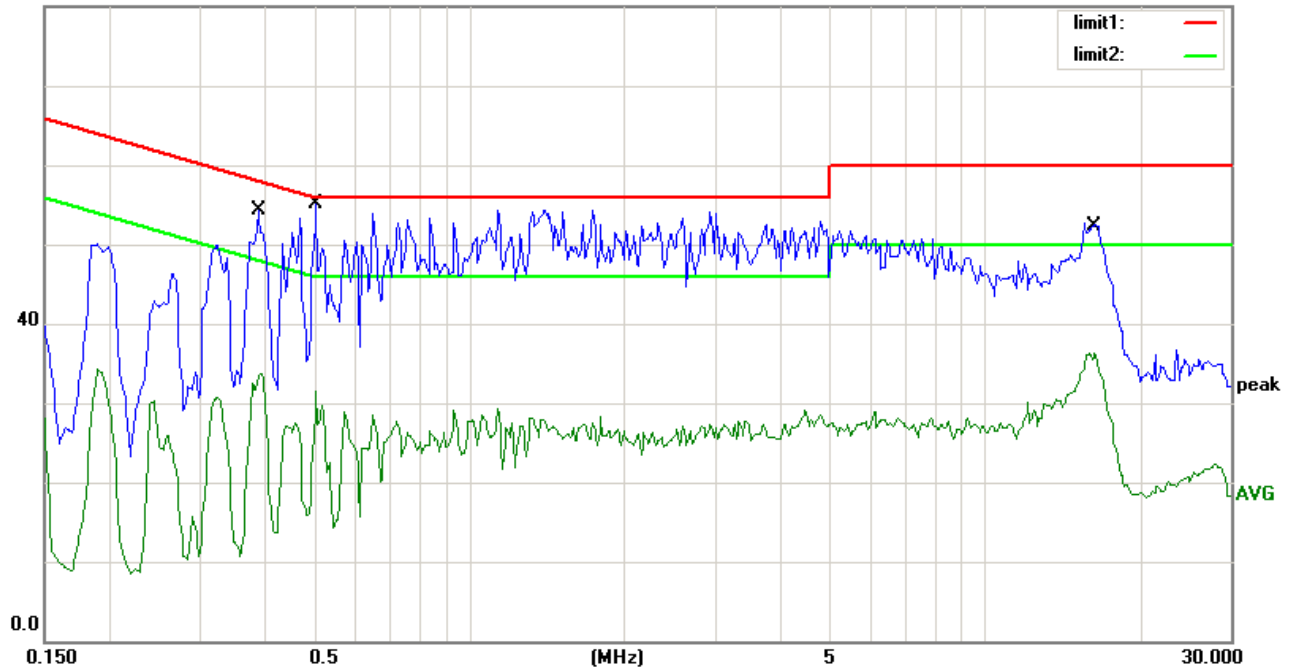

Site site #1

Phase: **L1**

Temperature: 25

Limit: (CE)FCC PART 15 class B_QP

Power: AC 120V/60Hz

Humidity: 50 %

EUT: 7 INCH DIGITAL PHOTO FRAME

M/N: DF-F7S

Mode: USB PLAYING

Note: ZDA050200US

No.	Mk.	Freq. MHz	Reading Level dBuV	Correct Factor dB	Measure- ment dBuV	Limit dBuV	Over dB	Detector	Comment
1		0.3914	50.21	0.00	50.21	58.03	-7.82	QP	
2		0.3914	33.56	0.00	33.56	48.03	-14.47	AVG	
3	*	0.5100	49.85	0.00	49.85	56.00	-6.15	QP	
4		0.5100	27.42	0.00	27.42	46.00	-18.58	AVG	
5		16.0250	50.95	0.00	50.95	60.00	-9.05	QP	
6		16.0250	36.32	0.00	36.32	50.00	-13.68	AVG	

*:Maximum data x:Over limit !:over margin Comment: Factor build in receiver. Operator:

Conducted Emission Measurement

File :DF-F7S
 80.0 dBuV

Data :#34

Date: 09/07/06/

Time: 10/59/41

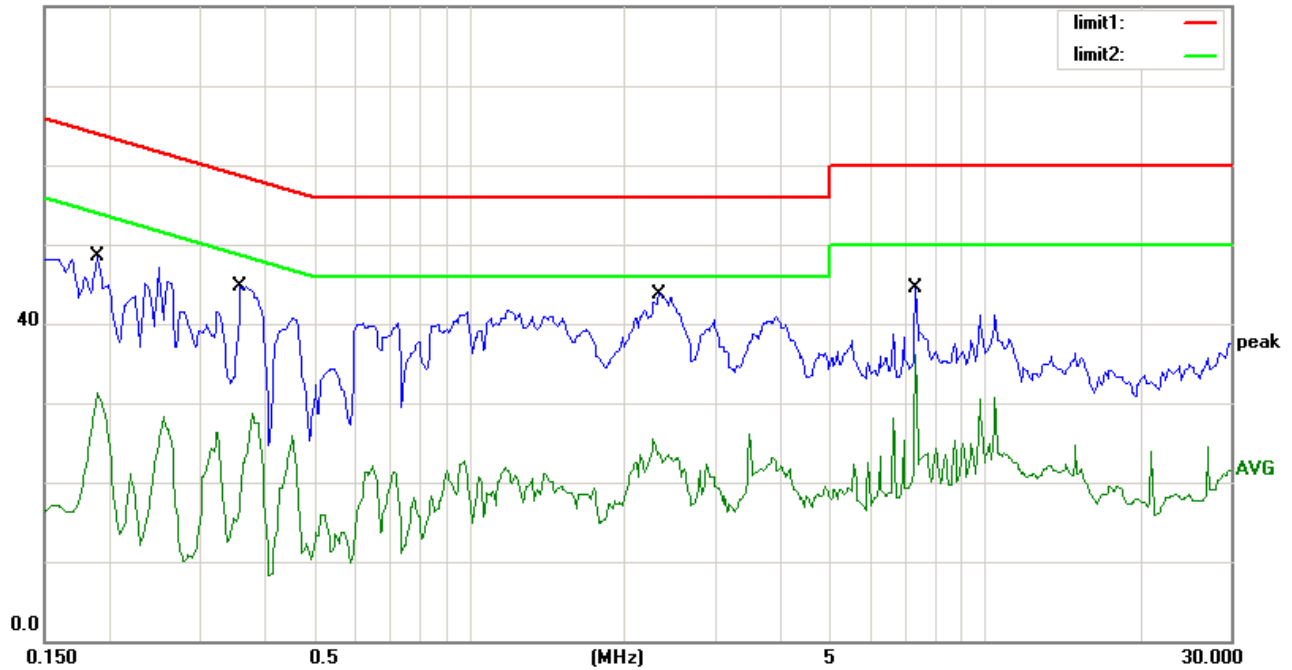

Site site #1

Phase: **L1**

Temperature: 25

Limit: (CE)FCC PART 15 class B_QP

Power: AC 120V/60Hz

Humidity: 50 %

EUT: 7 INCH DIGITAL PHOTO FRAME

M/N: DF-F7S

Mode: Memorying

Note: ZDA050200US

No.	Mk.	Freq.	Reading Level	Correct Factor	Measurement	Limit	Over	Detector	Comment
		MHz	dBuV	dB	dBuV	dBuV	dB		
1		0.1900	40.80	0.00	40.80	64.04	-23.24	QP	
2		0.1900	30.90	0.00	30.90	54.04	-23.14	AVG	
3		0.3600	39.70	0.00	39.70	58.73	-19.03	QP	
4		0.3600	18.50	0.00	18.50	48.73	-30.23	AVG	
5		2.3400	36.90	0.00	36.90	56.00	-19.10	QP	
6		2.3400	22.60	0.00	22.60	46.00	-23.40	AVG	
7		7.3300	41.50	0.00	41.50	60.00	-18.50	QP	
8	*	7.3300	34.90	0.00	34.90	50.00	-15.10	AVG	

*:Maximum data x:Over limit !:over margin Comment: Factor build in receiver. Operator:

Conducted Emission Measurement

File :DF-F7S
 80.0 dBuV

Data :#37

Date: 09/07/06/

Time: 11:05:36

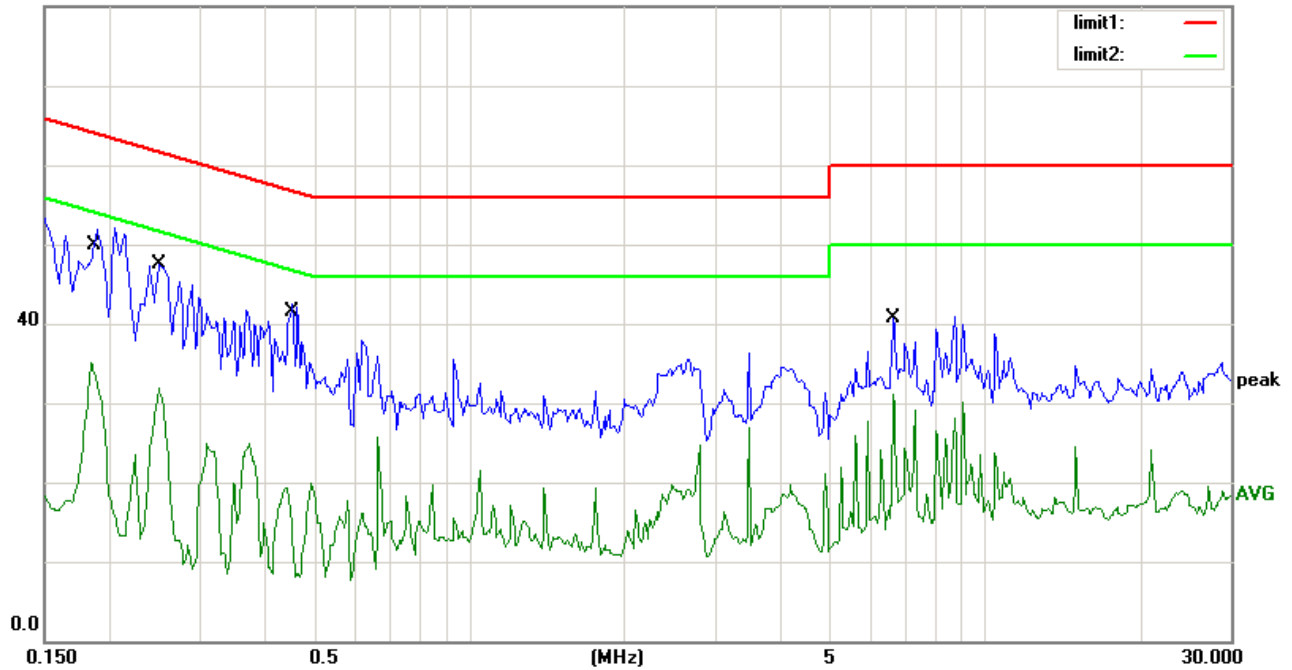

Site site #1

Phase: **N**

Temperature: 25

Limit: (CE)FCC PART 15 class B_QP

Power: AC 120V/60Hz

Humidity: 50 %

EUT: 7 INCH DIGITAL PHOTO FRAME

M/N: DF-F7S

Mode: Memorying

Note: ZDA050200US

No.	Mk.	Freq. MHz	Reading Level dBuV	Correct Factor dB	Measure- ment dBuV	Limit dBuV	Over dB	Detector	Comment
1	*	0.1850	49.64	0.00	49.64	64.26	-14.62	QP	
2		0.1850	35.07	0.00	35.07	54.26	-19.19	AVG	
3		0.2500	45.37	0.00	45.37	61.76	-16.39	QP	
4		0.2500	31.93	0.00	31.93	51.76	-19.83	AVG	
5		0.4450	40.62	0.00	40.62	56.97	-16.35	QP	
6		0.4450	19.22	0.00	19.22	46.97	-27.75	AVG	
7		6.6500	39.27	0.00	39.27	60.00	-20.73	QP	
8		6.6500	31.01	0.00	31.01	50.00	-18.99	AVG	

*:Maximum data x:Over limit !:over margin Comment: Factor build in receiver. Operator:

Conducted Emission Measurement

File :DF-F7S
 80.0 dBuV

Data :#39

Date: 09/07/06/

Time: 11/24/47

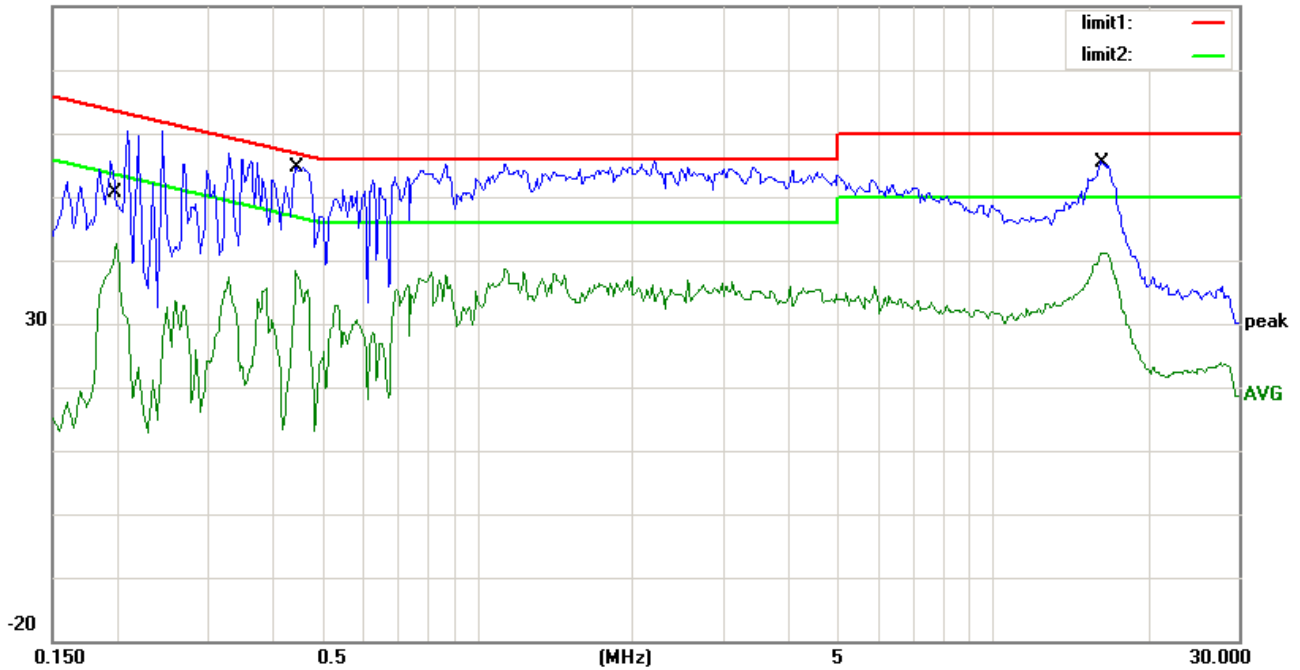

Site site #1

Limit: (CE)FCC PART 15 class B_QP
 EUT: 7 INCH DIGITAL PHOTO FRAME
 M/N: DF-F7S
 Mode: CONNECT TO PC
 Note: ZDA050200US

Phase: **L1**

Power: AC 120V/60Hz

Temperature: 25

Humidity: 50 %

No.	Mk.	Freq. MHz	Reading Level dBuV	Correct Factor dB	Measure- ment dBuV	Limit dBuV	Over dB	Detector	Comment
1		0.2007	52.60	0.00	52.60	63.58	-10.98	QP	
2		0.2007	42.72	0.00	42.72	53.58	-10.86	AVG	
3		0.4468	50.60	0.00	50.60	56.93	-6.33	QP	
4		0.4468	40.97	0.00	40.97	46.93	-5.96	AVG	
5	*	16.3985	55.74	0.00	55.74	60.00	-4.26	QP	
6		16.3985	41.07	0.00	41.07	50.00	-8.93	AVG	

*:Maximum data x:Over limit !:over margin Comment: Factor build in receiver. Operator:

Conducted Emission Measurement

File :DF-F7S
 80.0 dBuV

Data :#40

Date: 09/07/06/

Time: 11/43/56

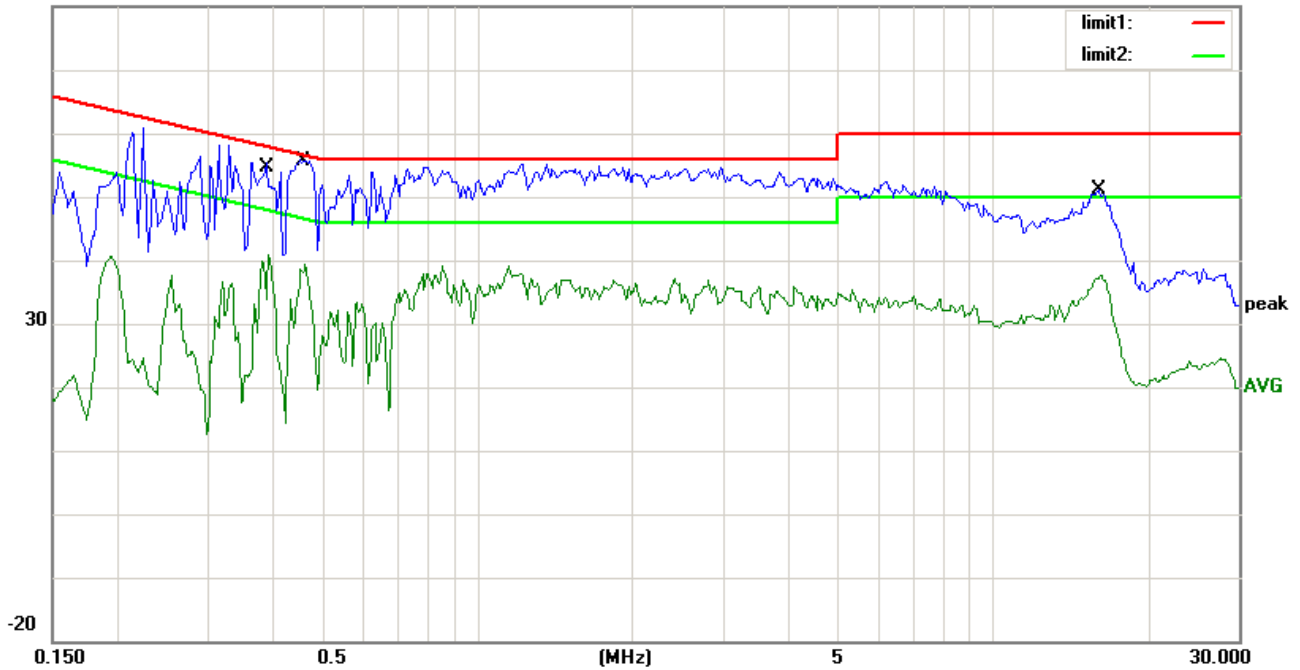

Site site #1

Phase: **N**

Temperature: 25

Limit: (CE)FCC PART 15 class B_QP

Power: AC 120V/60Hz

Humidity: 50 %

EUT: 7 INCH DIGITAL PHOTO FRAME

M/N: DF-F7S

Mode: CONNECT TO PC

Note: ZDA050200US

No.	Mk.	Freq. MHz	Reading Level dBuV	Correct Factor dB	Measure- ment dBuV	Limit dBuV	Over dB	Detector	Comment
1	*	0.3955	53.10	0.00	53.10	57.95	-4.85	QP	
2		0.3955	42.56	0.00	42.56	47.95	-5.39	AVG	
3		0.4600	51.40	0.00	51.40	56.69	-5.29	QP	
4		0.4600	40.89	0.00	40.89	46.69	-5.80	AVG	
5		16.2250	45.50	0.00	45.50	60.00	-14.50	QP	
6		16.2250	37.53	0.00	37.53	50.00	-12.47	AVG	

*:Maximum data x:Over limit !:over margin Comment: Factor build in receiver. Operator:

Adapter XKD-C2000IC5.0-12W used for test.

Conducted Emission Measurement

File :DF-F7S
 80.0 dBuV

Data :#23

Date: 09/07/06/

Time: 9/21/30

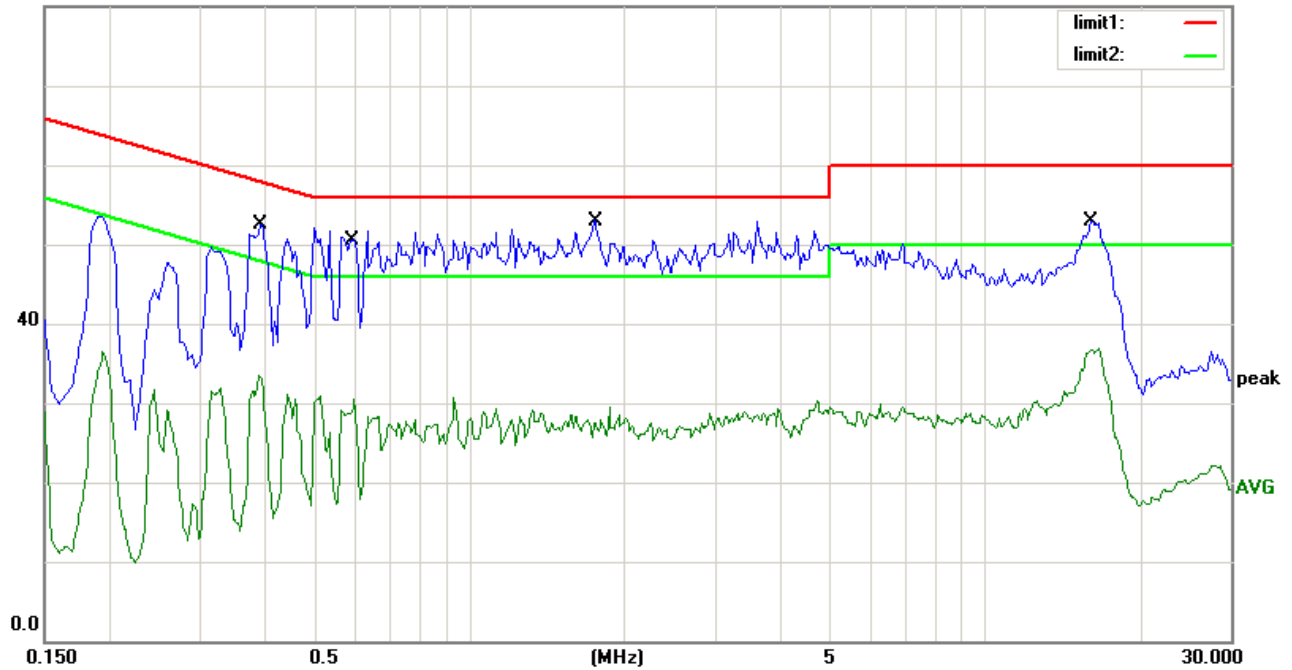

Site site #1

Phase: **N**

Temperature: 25

Limit: (CE)FCC PART 15 class B_QP

Power: AC 120V/60Hz

Humidity: 50 %

EUT: 7 INCH DIGITAL PHOTO FRAME

M/N: DF-F7S

Mode: Memorying

Note: XKD-C2000IC5.0-12W

No.	Mk.	Freq. MHz	Reading Level dBuV	Correct Factor dB	Measure- ment dBuV	Limit dBuV	Over dB	Detector	Comment
1	*	0.3914	49.70	0.00	49.70	58.03	-8.33	QP	
2		0.3914	35.40	0.00	35.40	48.03	-12.63	AVG	
3		0.5854	47.30	0.00	47.30	56.00	-8.70	QP	
4		0.5854	29.40	0.00	29.40	46.00	-16.60	AVG	
5		1.7716	44.30	0.00	44.30	56.00	-11.70	QP	
6		1.7716	26.60	0.00	26.60	46.00	-19.40	AVG	
7		16.1400	46.50	0.00	46.50	60.00	-13.50	QP	
8		16.1400	35.20	0.00	35.20	50.00	-14.80	AVG	

*:Maximum data x:Over limit !:over margin Comment: Factor build in receiver. Operator:

Conducted Emission Measurement

File :DF-F7S
 80.0 dBuV

Data :#24

Date: 09/07/06/

Time: 9/28/39

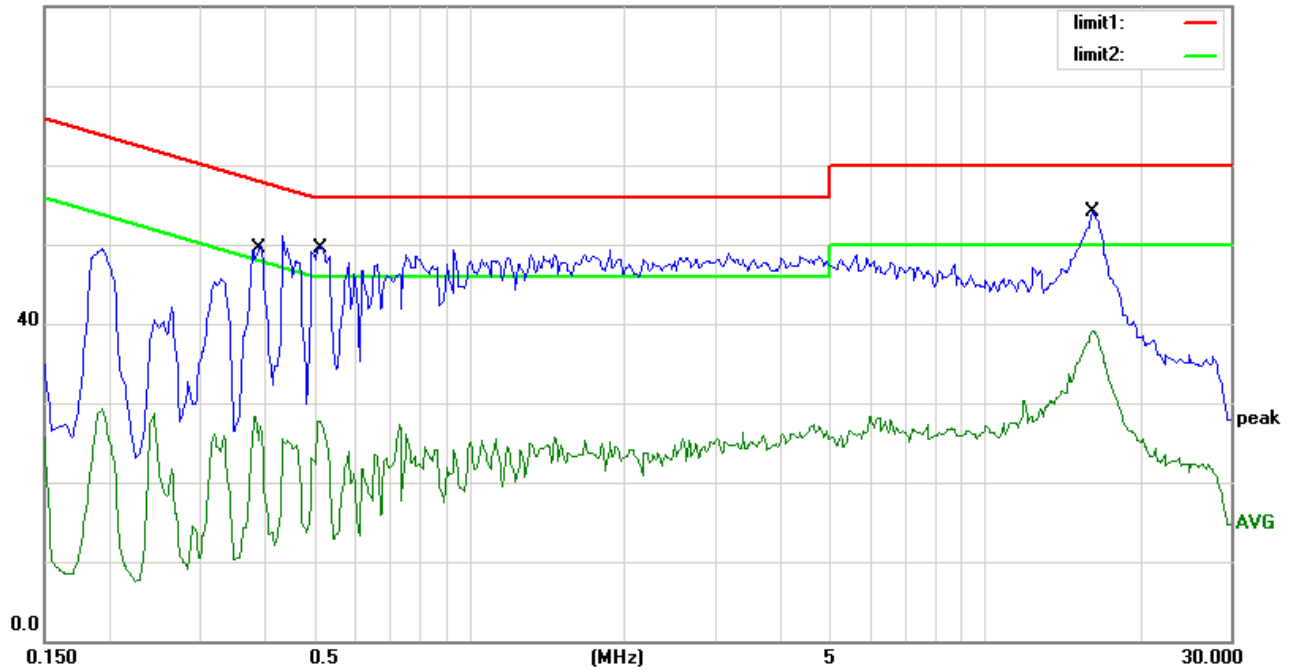

Site site #1

Phase: **L1**

Temperature: 25

Limit: (CE)FCC PART 15 class B_QP

Power: AC 120V/60Hz

Humidity: 50 %

EUT: 7 INCH DIGITAL PHOTO FRAME

M/N: DF-F7S

Mode: Memorying

Note: XKD-C2000IC5.0-12W

No.	Mk.	Freq.	Reading Level	Correct Factor	Measurement	Limit	Over	Detector	Comment
		MHz	dBuV	dB	dBuV	dBuV	dB		
1		0.3871	43.40	0.00	43.40	58.13	-14.73	QP	
2		0.3871	26.30	0.00	26.30	48.13	-21.83	AVG	
3		0.5101	44.10	0.00	44.10	56.00	-11.90	QP	
4		0.5101	25.70	0.00	25.70	46.00	-20.30	AVG	
5		16.2250	46.90	0.00	46.90	60.00	-13.10	QP	
6	*	16.2250	39.50	0.00	39.50	50.00	-10.50	AVG	

*:Maximum data x:Over limit !:over margin Comment: Factor build in receiver. Operator:

Conducted Emission Measurement

File :DF-F7S
 80.0 dBuV

Data :#25

Date: 09/07/06/

Time: 9/39/47

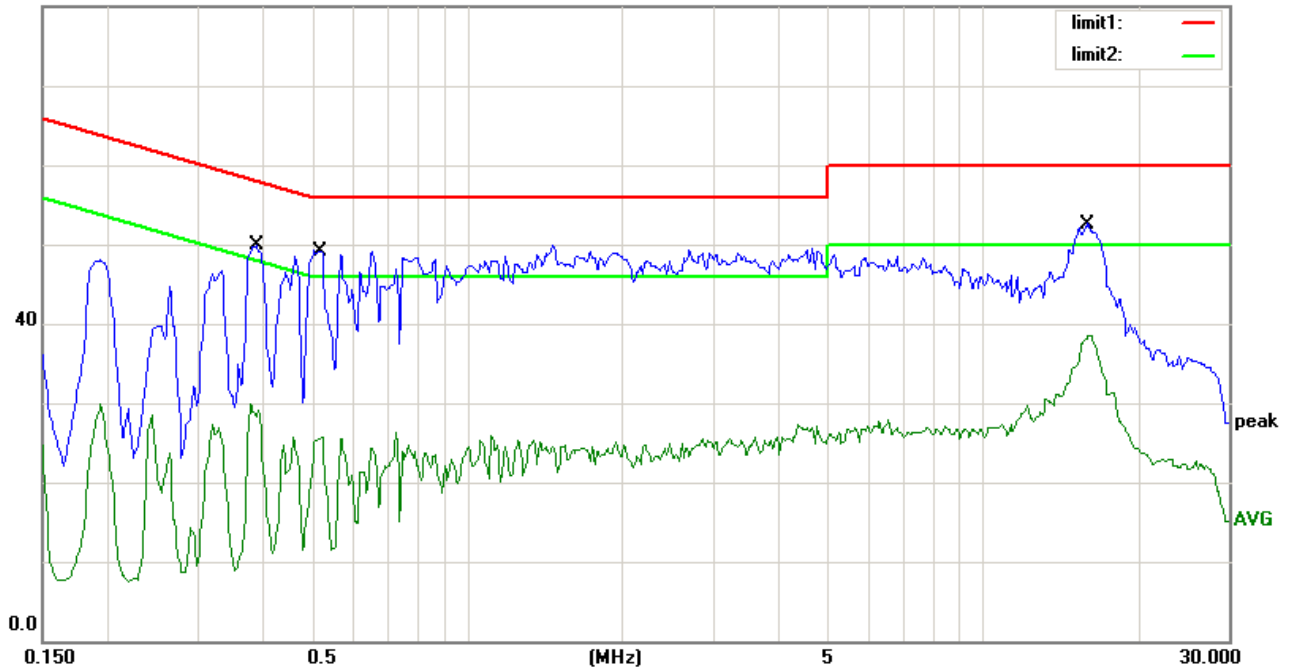

Site site #1

Phase: **L1**

Temperature: 25

Limit: (CE)FCC PART 15 class B_QP

Power: AC 120V/60Hz

Humidity: 50 %

EUT: 7 INCH DIGITAL PHOTO FRAME

M/N: DF-F7S

Mode: SD CARD PLAYING

Note: XKD-C2000IC5.0-12W

No.	Mk.	Freq. MHz	Reading Level dBuV	Correct Factor dB	Measure- ment dBuV	Limit dBuV	Over dB	Detector	Comment
1		0.3852	45.40	0.00	45.40	58.17	-12.77	QP	
2		0.3852	29.50	0.00	29.50	48.17	-18.67	AVG	
3		0.5200	41.80	0.00	41.80	56.00	-14.20	QP	
4		0.5200	24.20	0.00	24.20	46.00	-21.80	AVG	
5		16.0250	47.20	0.00	47.20	60.00	-12.80	QP	
6	*	16.0250	38.00	0.00	38.00	50.00	-12.00	AVG	

*:Maximum data x:Over limit !:over margin Comment: Factor build in receiver. Operator:

Conducted Emission Measurement

File :DF-F7S
 80.0 dBuV

Data :#26

Date: 09/07/06/

Time: 9/49/38

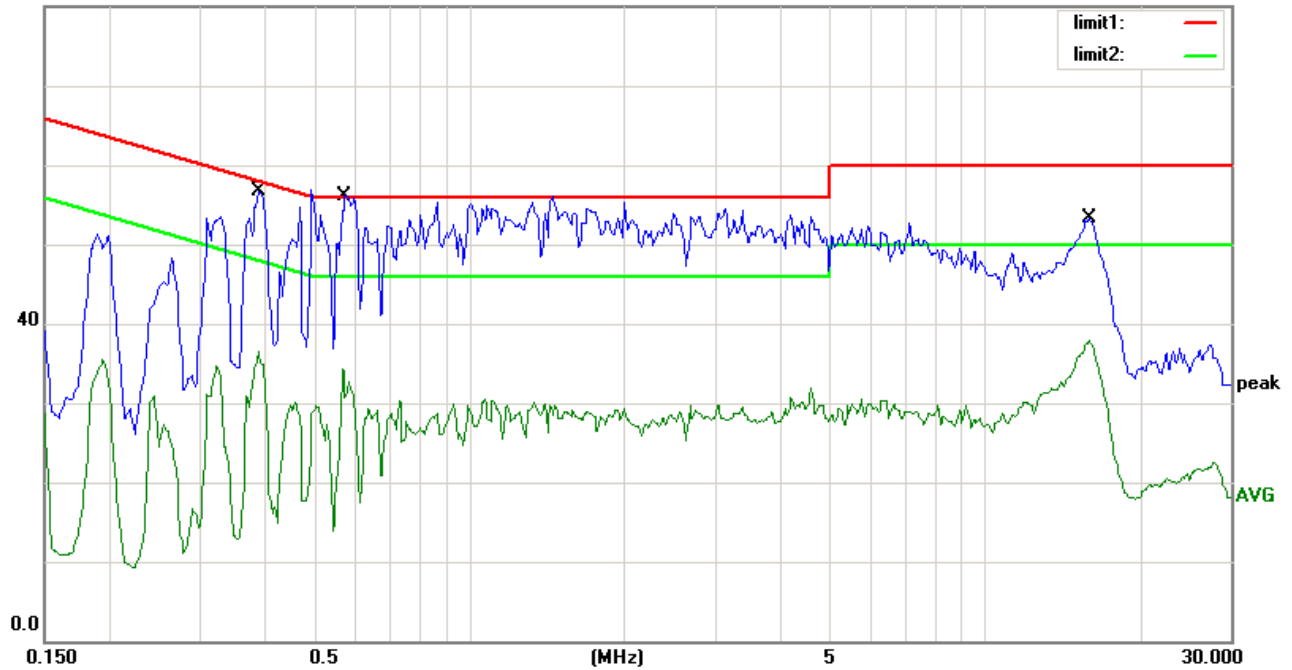

Site site #1

Phase: **N**

Temperature: 25

Limit: (CE)FCC PART 15 class B_QP

Power: AC 120V/60Hz

Humidity: 50 %

EUT: 7 INCH DIGITAL PHOTO FRAME

M/N: DF-F7S

Mode: SD CARD PLAYING

Note: XKD-C2000IC5.0-12W

No.	Mk.	Freq. MHz	Reading Level dBuV	Correct Factor dB	Measure- ment dBuV	Limit dBuV	Over dB	Detector	Comment
1	*	0.3914	50.90	0.00	50.90	58.03	-7.13	QP	
2		0.3914	36.30	0.00	36.30	48.03	-11.73	AVG	
3		0.5762	38.90	0.00	38.90	56.00	-17.10	QP	
4		0.5762	24.60	0.00	24.60	46.00	-21.40	AVG	
5		15.8000	46.30	0.00	46.30	60.00	-13.70	QP	
6		15.8000	35.40	0.00	35.40	50.00	-14.60	AVG	

*:Maximum data x:Over limit !:over margin Comment: Factor build in receiver. Operator:

Conducted Emission Measurement

File :DF-F7S
 80.0 dBuV

Data :#27

Date: 09/07/06/

Time: 9/54/35

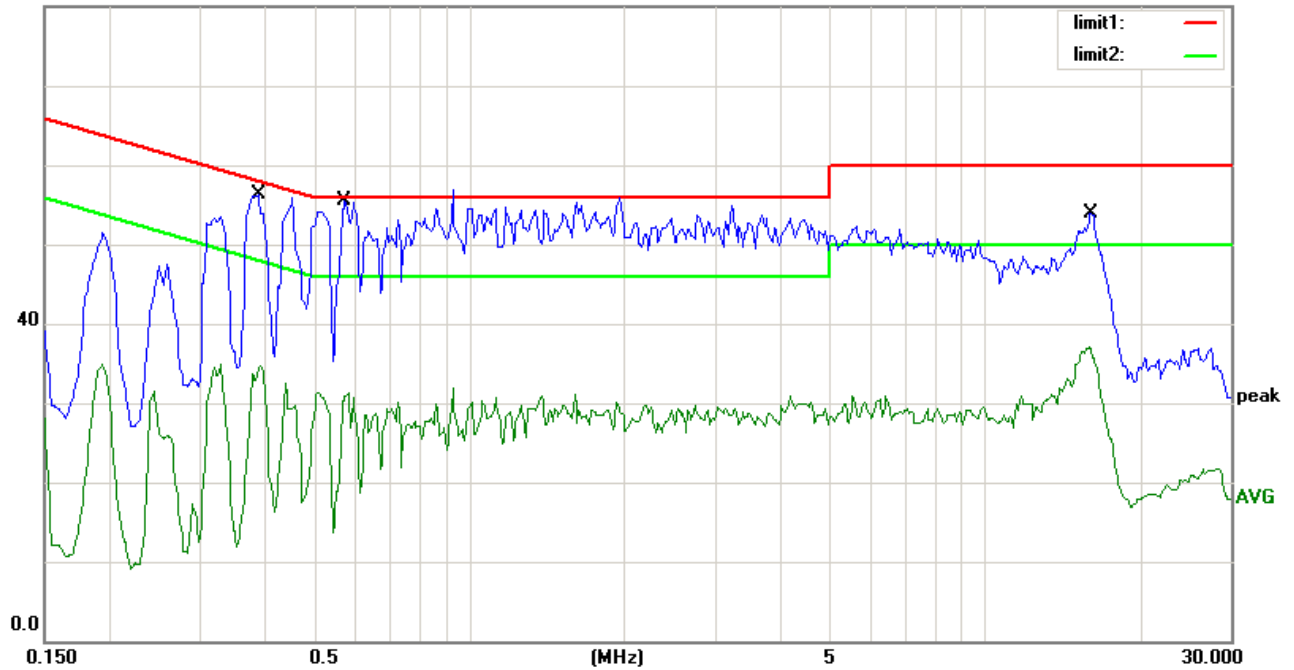

Site site #1

Limit: (CE)FCC PART 15 class B_QP
 EUT: 7 INCH DIGITAL PHOTO FRAME
 M/N: DF-F7S
 Mode: USB PLAYING
 Note: XKD-C2000IC5.0-12W

Phase: **N**

Power: AC 120V/60Hz

Temperature: 25

Humidity: 50 %

No.	Mk.	Freq. MHz	Reading Level dBuV	Correct Factor dB	Measure- ment dBuV	Limit dBuV	Over dB	Detector	Comment
1	*	0.3914	50.10	0.00	50.10	58.03	-7.93	QP	
2		0.3914	35.40	0.00	35.40	48.03	-12.63	AVG	
3		0.5792	46.80	0.00	46.80	56.00	-9.20	QP	
4		0.5792	29.00	0.00	29.00	46.00	-17.00	AVG	
5		16.2250	46.00	0.00	46.00	60.00	-14.00	QP	
6		16.2250	36.60	0.00	36.60	50.00	-13.40	AVG	

*:Maximum data x:Over limit !:over margin Comment: Factor build in receiver. Operator:

Conducted Emission Measurement

File :DF-F7S
 80.0 dBuV

Data :#28

Date: 09/07/06/

Time: 10/00/47

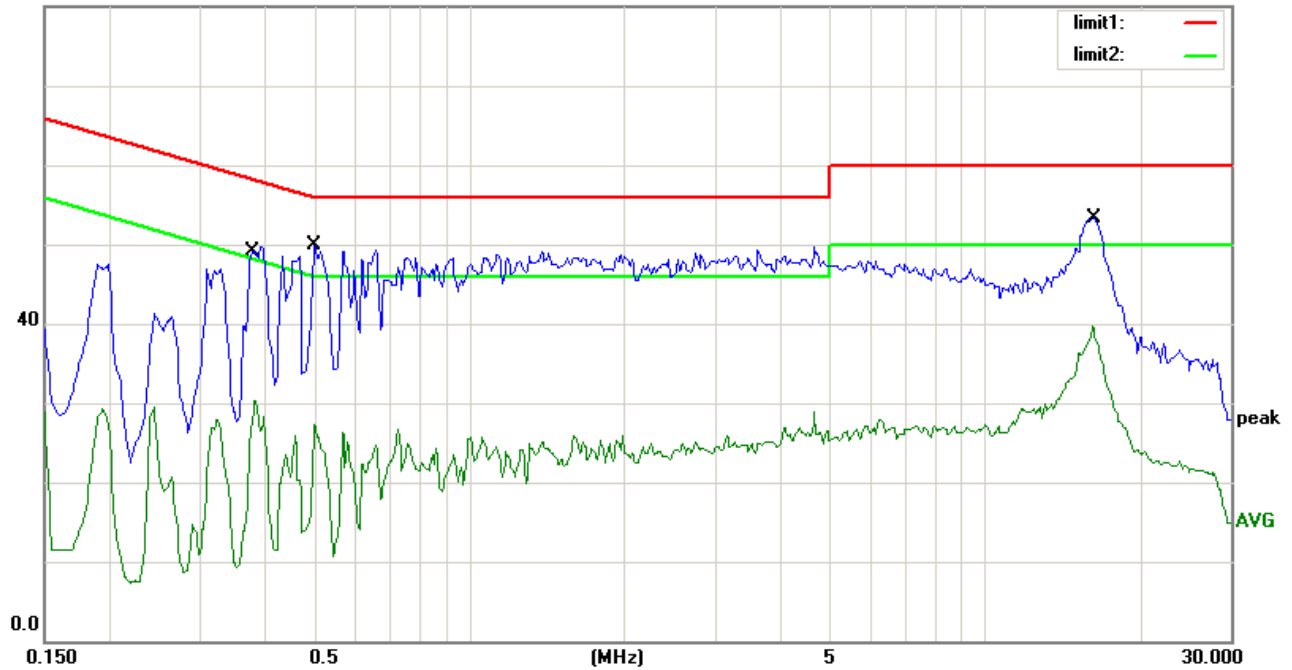

Site site #1

Phase: **L1**

Temperature: 25

Limit: (CE)FCC PART 15 class B_QP

Power: AC 120V/60Hz

Humidity: 50 %

EUT: 7 INCH DIGITAL PHOTO FRAME

M/N: DF-F7S

Mode: USB PLAYING

Note: XKD-C2000IC5.0-12W

No.	Mk.	Freq.	Reading Level	Correct Factor	Measurement	Limit	Over	Detector	Comment
		MHz	dBuV	dB	dBuV	dBuV	dB		
1		0.3800	45.30	0.00	45.30	58.28	-12.98	QP	
2		0.3800	28.90	0.00	28.90	48.28	-19.38	AVG	
3	*	0.5047	44.70	0.00	44.70	56.00	-11.30	QP	
4		0.5047	25.40	0.00	25.40	46.00	-20.60	AVG	
5		16.3750	46.20	0.00	46.20	60.00	-13.80	QP	
6		16.3750	38.10	0.00	38.10	50.00	-11.90	AVG	

*:Maximum data x:Over limit !:over margin Comment: Factor build in receiver. Operator:

Conducted Emission Measurement

File :DF-F7S
 80.0 dBuV

Data :#43

Date: 09/07/06/

Time: 14/40/38

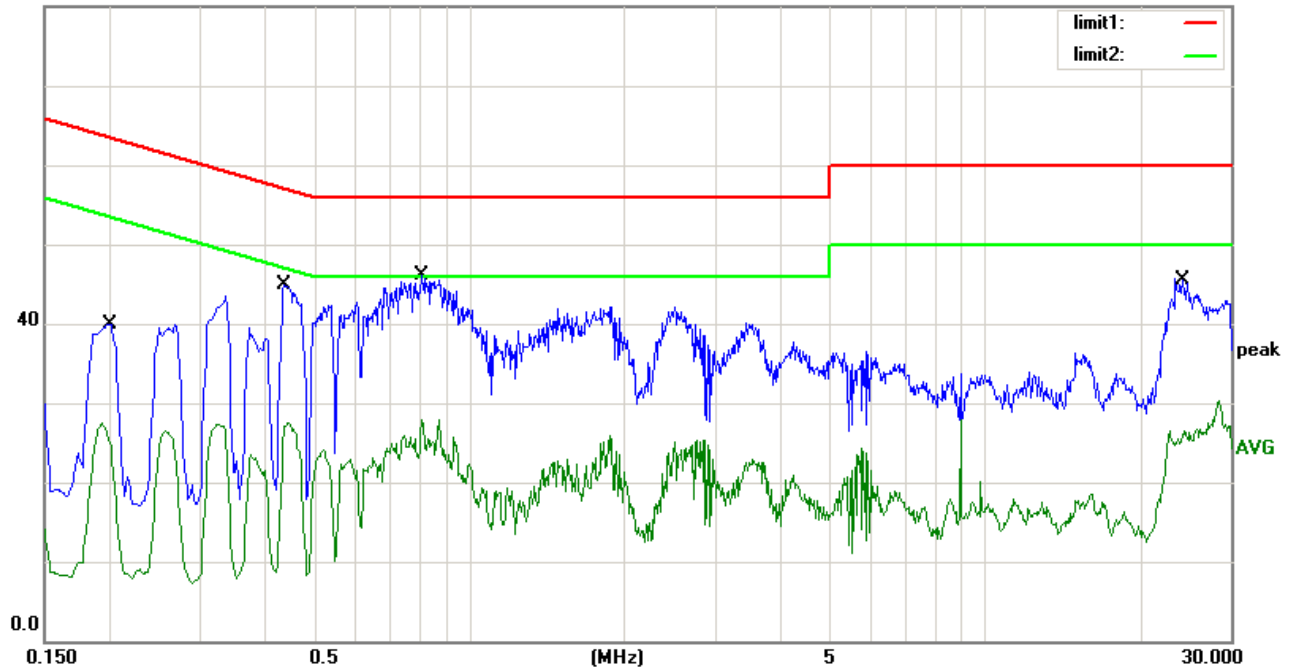

Site site #1

Limit: (CE)FCC PART 15 class B_QP
 EUT: 7 INCH DIGITAL PHOTO FRAME
 M/N: DF-F7S
 Mode: CONNECT TO PC
 Note: XKD-C2000IC5.0-12W

Phase: **L1**

Power: AC 120V/60Hz

Temperature: 25

Humidity: 60 %

No.	Mk.	Freq. MHz	Reading Level dBuV	Correct Factor dB	Measure- ment dBuV	Limit dBuV	Over dB	Detector	Comment
1		0.1980	37.35	0.00	37.35	63.69	-26.34	QP	
2		0.1980	26.75	0.00	26.75	53.69	-26.94	AVG	
3		0.4380	42.35	0.00	42.35	57.10	-14.75	QP	
4		0.4380	26.95	0.00	26.95	47.10	-20.15	AVG	
5	*	0.8100	44.15	0.00	44.15	56.00	-11.85	QP	
6		0.8100	28.05	0.00	28.05	46.00	-17.95	AVG	
7		24.1620	35.25	0.00	35.25	60.00	-24.75	QP	
8		24.1620	23.25	0.00	23.25	50.00	-26.75	AVG	

*:Maximum data x:Over limit !:over margin Comment: Factor build in receiver. Operator:

Conducted Emission Measurement

File :DF-F7S
 80.0 dBuV

Data :#44

Date: 09/07/06/

Time: 14/45/41

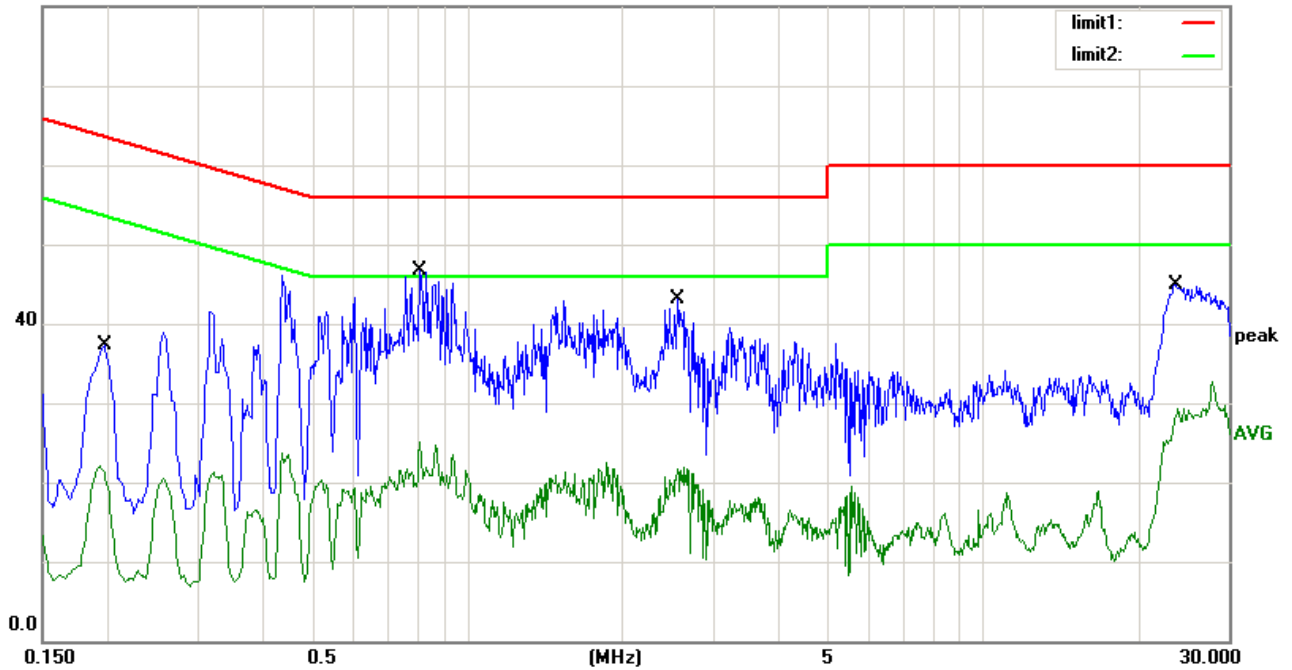

Site site #1

Phase: **N**

Temperature: 25

Limit: (CE)FCC PART 15 class B_QP

Power: AC 120V/60Hz

Humidity: 60 %

EUT: 7 INCH DIGITAL PHOTO FRAME

M/N: DF-F7S

Mode: CONNECT TO PC

Note: XKD-C2000IC5.0-12W

No.	Mk.	Freq. MHz	Reading Level dBuV	Correct Factor dB	Measure- ment dBuV	Limit dBuV	Over dB	Detector	Comment
1		0.1980	32.25	0.00	32.25	63.69	-31.44	QP	
2		0.1980	21.15	0.00	21.15	53.69	-32.54	AVG	
3	*	0.8100	37.35	0.00	37.35	56.00	-18.65	QP	
4		0.8100	23.45	0.00	23.45	46.00	-22.55	AVG	
5		2.5620	33.85	0.00	33.85	56.00	-22.15	QP	
6		2.5620	21.45	0.00	21.45	46.00	-24.55	AVG	
7		23.6780	37.35	0.00	37.35	60.00	-22.65	QP	
8		23.6780	25.65	0.00	25.65	50.00	-24.35	AVG	

*:Maximum data x:Over limit !:over margin Comment: Factor build in receiver. Operator:

3. RADIATED EMISSION MEASUREMENT

3.1. Test Equipment

The following test equipments are used during the radiated emission measurement:

3.1.1. For Anechoic Chamber

Item	Equipment	Manufacturer	Model No.	Serial No.	Last Cal.	Cal. Interval
1.	Spectrum Analyzer	Rohde & Schwarz	ESCI	100137	May 20, 2009	1 Year
2.	Test Receiver	Rohde & Schwarz	ESCI	100137	May 20, 2009	1 Year
3.	Bilog Antenna	Schwarzbeck	VULB9163	143	May 20, 2009	1 Year
4.	Power Amplifier	HP	8447F	OPT H64	May 20, 2009	1 Year
5.	Positioning Controller	C&C LAB	CC-C-IF	N/A	May 20, 2009	1 Year
6.	Color Monitor	SUNSPO	SP-140A	N/A	May 20, 2009	1 Year
7.	Single Line Filter	JIANLI	XL-3	N/A	May 20, 2009	1 Year
8.	Single Phase Power Line Filter	JIANLI	DL-2X100B	N/A	May 20, 2009	1 Year
9.	3 Phase Power Line Filter	JIANLI	DL-4X100B	N/A	May 20, 2009	1 Year
10.	DC Power Filter	JIANLI	DL-2X50B	N/A	May 20, 2009	1 Year
11.	Cable	Schwarzbeck	PLF-100	N/A	May 20, 2009	1 Year
12.	Cable	Rosenberger	CIL02	A0783566	May 20, 2009	1 Year
13.	Cable	Rosenberger	AK9513	AC RX1	May 20, 2009	1 Year

3.2. Block Diagram of Test Setup

3.2.1. Block diagram of connection between the EUT and simulators

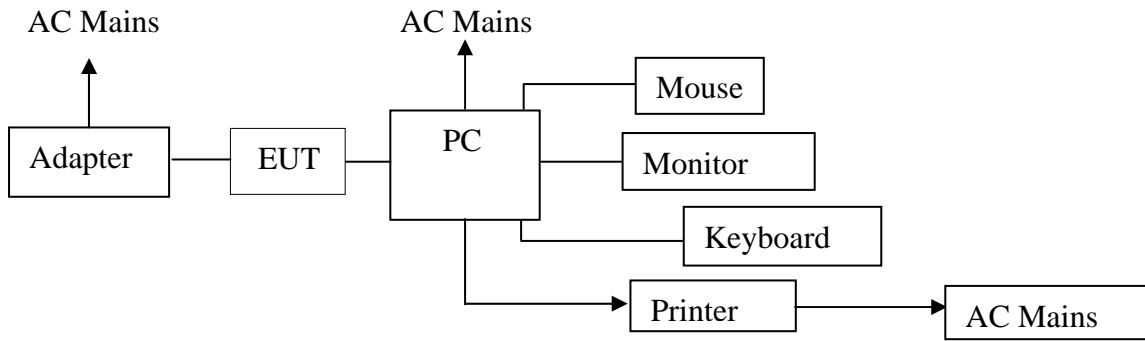

(EUT: 7 inch Digital Photo Frame)

3.2.2. Anechoic Chamber Test Setup Diagram

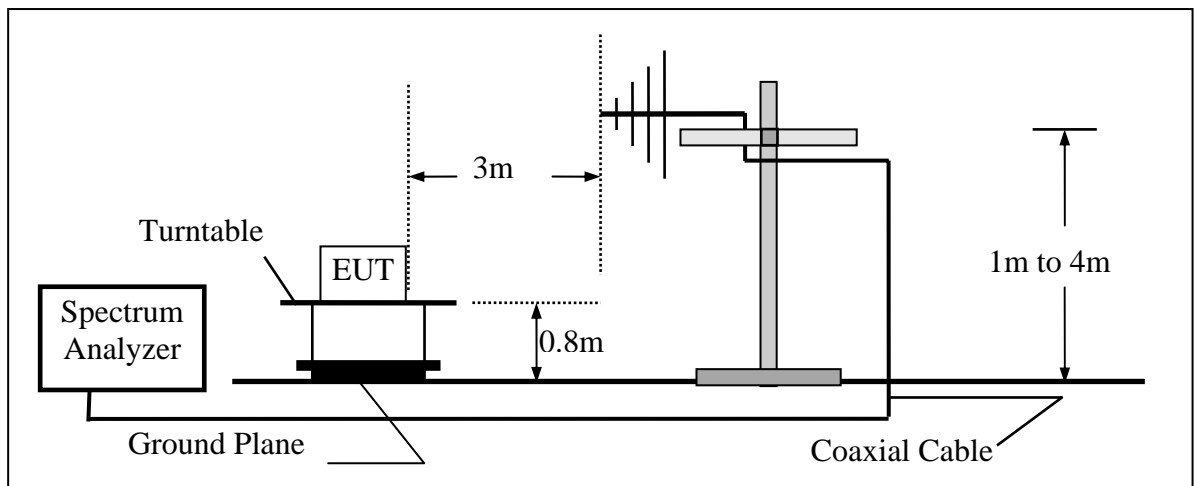

(EUT: 7 inch Digital Photo Frame)

3.3. Radiated Emission Limit

Radiated Emission Limits is as following.

FREQUENCY MHz	DISTANCE Meters	FIELD STRENGTHS LIMIT
		dB(μV)/m
30 ~ 88	3	40.0
88 ~ 216	3	43.5
216 ~ 960	3	46.0
960 ~ 1000	3	54.0
>1000	3	74.0 dB(μV)/m (peak) 54.0 dB(μV)/m (Average)

- Remark :
- (1) Emission level (dB)μV = 20 log Emission level μV/m
 - (2) The smaller limit shall apply at the cross point between two frequency bands.
 - (3) Distance is the distance in meters between the measuring instrument, antenna and the closest point of any part of the device or system.

3.4.EUT Configuration on Measurement

The following equipment are installed on Radiated Emission Measurement to meet the commission requirements and operating regulations in a manner which tends to maximize its emission characteristics in normal application.

7 inch Digital Photo Frame (EUT)

Model Number : DF-F7S

3.5.Operating Condition of EUT

3.5.1 Setup the EUT as shown in Section 3.2.

3.5.2 Turn on the power of all equipment.

3.5.3 Let the EUT work in test mode (Memorying, SD Card Playing, USB Playing, Connect to PC) and measure it.

3.6.Test Procedure

EUT and its simulators are placed on a turntable, which is 0.8 meter high above ground. The turn table can rotate 360 degrees to determine the position of the maximum emission level. EUT is set 3.0 meters away from the receiving antenna, which is mounted on a antenna tower. The antenna can be moved up and down between 1.0 meter and 4 meters to find out the maximum emission level. Broadband antenna (calibrated bilog antenna) is used as receiving antenna. Both horizontal and vertical polarization of the antenna is set on measurement. In order to find the maximum emission levels, all of the interface cables must be manipulated according to ANSI C63.4-2003 on radiated emission measurement.

The bandwidth of the EMI test receiver (R&S ESCI) set at 120KHz in 30MHz to 1000MHz, set at 1MHz above 1000MHz.

The frequency range from 30MHz to 1000MHz is checked.

3.7.Radiated Emission Noise Measurement Results

PASS.

The scanning waveforms refer to the following pages:

Adapter ADS-12G-0605010GPCU used for test.

Radiated Emission Measurement

File :DF-F7S

Data :#1

Date: 2009/07/03

Time: 15:49:14

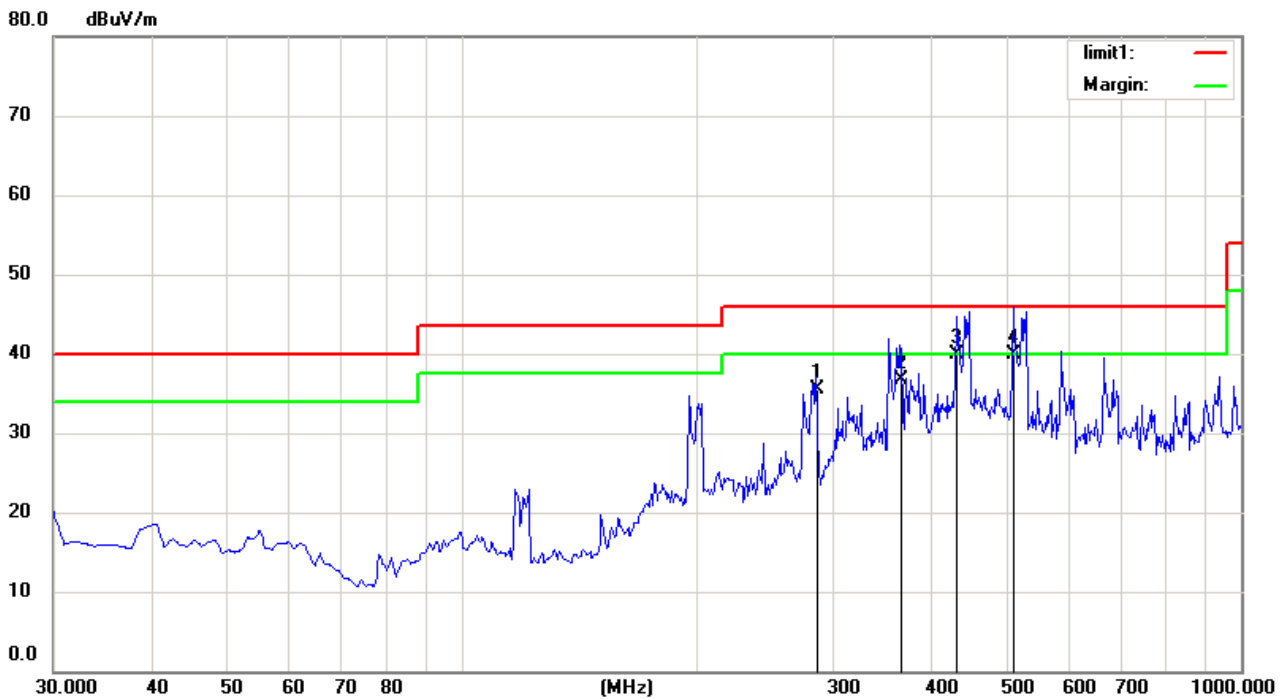

Site Chamber #1

Polarization: **Horizontal**

Temperature: 26

Limit: (RE)FCC PART 15 class B 3m

Power: AC 120V/60Hz

Humidity: 55 %

EUT: 7 INCH DIGITAL PHOTO FRAME

M/N: DF-F7S

Mode: Memorying

Note: ADS-12G-06 05010GPCU

No.	Mk.	Freq.	Reading Level	Correct Factor	Measurement	Limit	Over	Antenna Height	Table Degree	
		MHz	dBuV	dB	dBuV/m	dBuV/m	dB	cm	degree	Comment
1		285.1100	46.52	-11.06	35.46	46.00	-10.54	QP		
2		366.5900	46.29	-9.56	36.73	46.00	-9.27	QP		
3		431.5800	48.23	-8.31	39.92	46.00	-6.08	QP		
4	*	510.1500	47.05	-7.06	39.99	46.00	-6.01	QP		

*:Maximum data x:Over limit !:over margin

Operator:

Radiated Emission Measurement

File :DF-F7S

Data :#2

Date: 2009/07/03

Time: 15:53:32

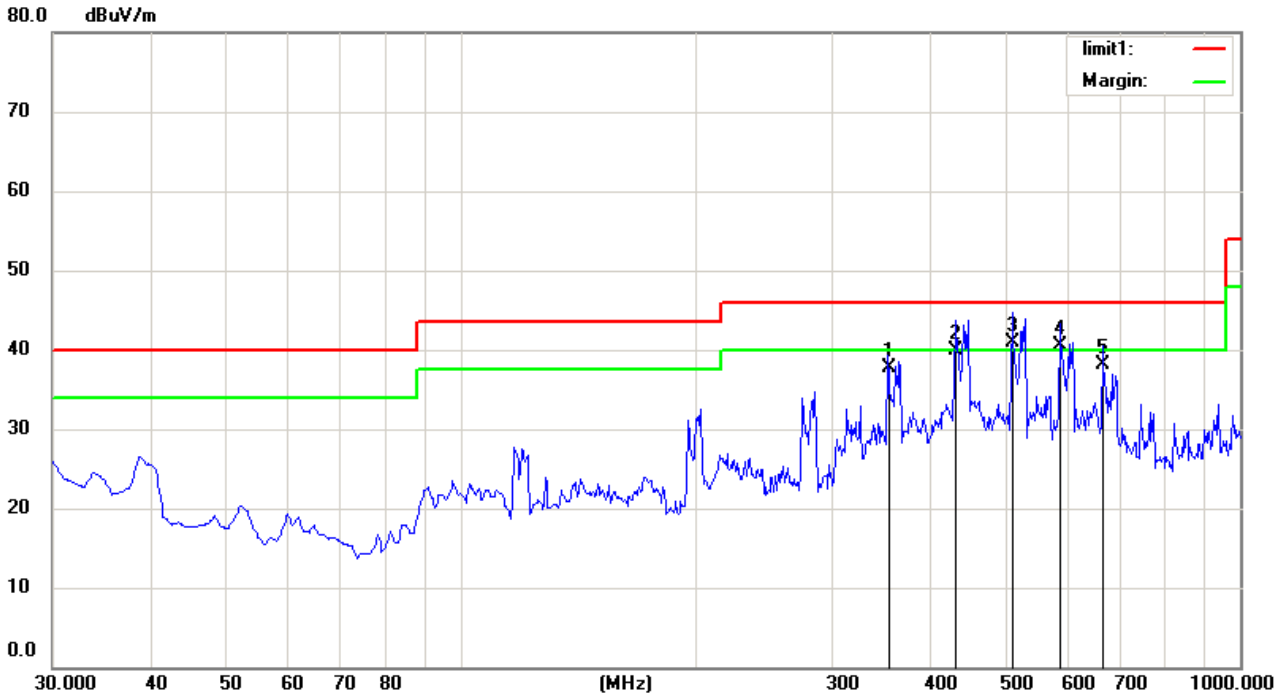

Site Chamber #1

Polarization: **Vertical**

Temperature: 26

Limit: (RE)FCC PART 15 class B 3m

Power: AC 120V/60Hz

Humidity: 55 %

EUT: 7 INCH DIGITAL PHOTO FRAME

M/N: DF-F7S

Mode: Memorying

Note: ADS-12G-06 05010GPCU

No.	Mk.	Freq.	Reading Level	Correct Factor	Measurement	Limit	Over	Antenna Height	Table Degree	
		MHz	dBuV	dB	dBuV/m	dBuV/m	dB	cm	degree	Comment
1		353.0100	47.52	-9.73	37.79	46.00	-8.21	QP		
2		431.5800	48.30	-8.31	39.99	46.00	-6.01	QP		
3	*	510.1500	48.05	-7.06	40.99	46.00	-5.01	QP		
4	!	588.7200	46.31	-5.84	40.47	46.00	-5.53	QP		
5		667.2900	42.95	-4.93	38.02	46.00	-7.98	QP		

*:Maximum data x:Over limit !:over margin

Operator:

Radiated Emission Measurement

File :DF-F7S

Data :#3

Date: 2009/07/03

Time: 16:22:13

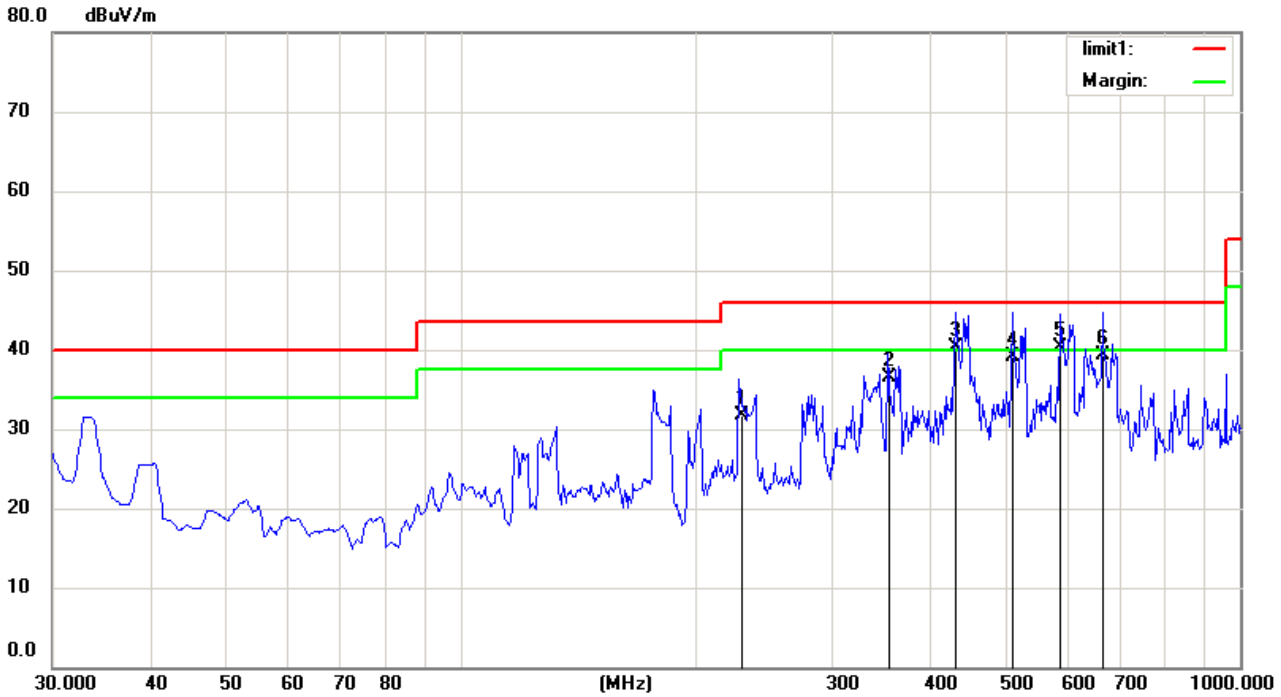

Site Chamber #1

Polarization: **Vertical**

Temperature: 26

Limit: (RE)FCC PART 15 class B 3m

Power: AC 120V/60Hz

Humidity: 55 %

EUT: 7 INCH DIGITAL PHOTO FRAME

M/N: DF-F7S

Mode: USB PLAYING

Note: ADS-12G-06 05010GPCU

No.	Mk.	Freq. MHz	Reading Level dBuV	Correct Factor dB	Measure- ment dBuV/m	Limit dBuV/m	Over dB	Antenna Height cm	Table Degree degree	Comment
1		228.8500	44.35	-12.62	31.73	46.00	-14.27	QP		
2		353.0100	46.31	-9.73	36.58	46.00	-9.42	QP		
3	!	431.5800	48.59	-8.31	40.28	46.00	-5.72	QP		
4		510.1500	46.15	-7.06	39.09	46.00	-6.91	QP		
5	*	588.7200	46.14	-5.84	40.30	46.00	-5.70	QP		
6		667.2900	44.28	-4.93	39.35	46.00	-6.65	QP		

*:Maximum data x:Over limit !:over margin

Operator:

Radiated Emission Measurement

File :DF-F7S

Data :#4

Date: 2009/07/03

Time: 16:26:58

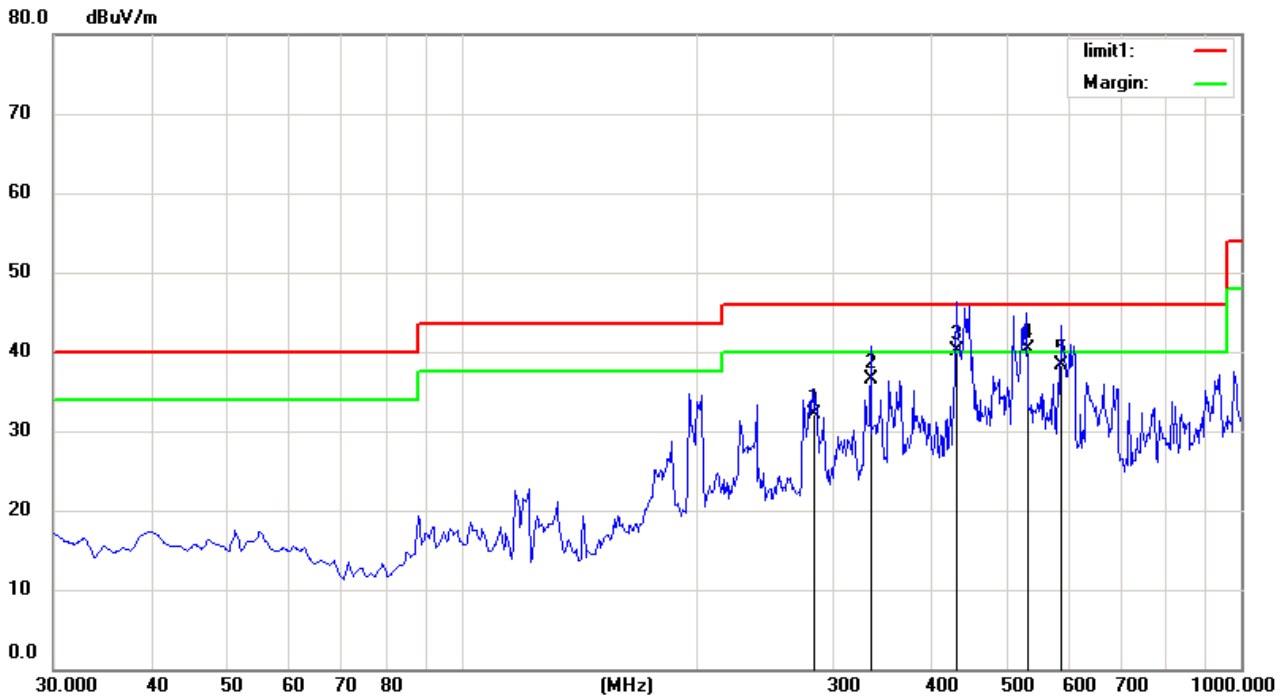

Site Chamber #1

Polarization: **Horizontal**

Temperature: 26

Limit: (RE)FCC PART 15 class B 3m

Power: AC 120V/60Hz

Humidity: 55 %

EUT: 7 INCH DIGITAL PHOTO FRAME

M/N: DF-F7S

Mode: USB PLAYING

Note: ADS-12G-06 05010GPCU

No.	Mk.	Freq.	Reading Level	Correct Factor	Measurement	Limit	Over	Antenna Height	Table Degree	
		MHz	dBuV	dB	dBuV/m	dBuV/m	dB	Detector	cm	degree
1		282.2000	43.25	-11.17	32.08	46.00	-13.92	QP		
2		335.5500	46.57	-10.04	36.53	46.00	-9.47	QP		
3	!	431.5800	48.45	-8.31	40.14	46.00	-5.86	QP		
4	*	530.5200	47.19	-6.95	40.24	46.00	-5.76	QP		
5		588.7200	44.12	-5.84	38.28	46.00	-7.72	QP		

*:Maximum data x:Over limit !:over margin

Operator:

Radiated Emission Measurement

File :DF-F7S

Data :#5

Date: 2009/07/03

Time: 16:35:07

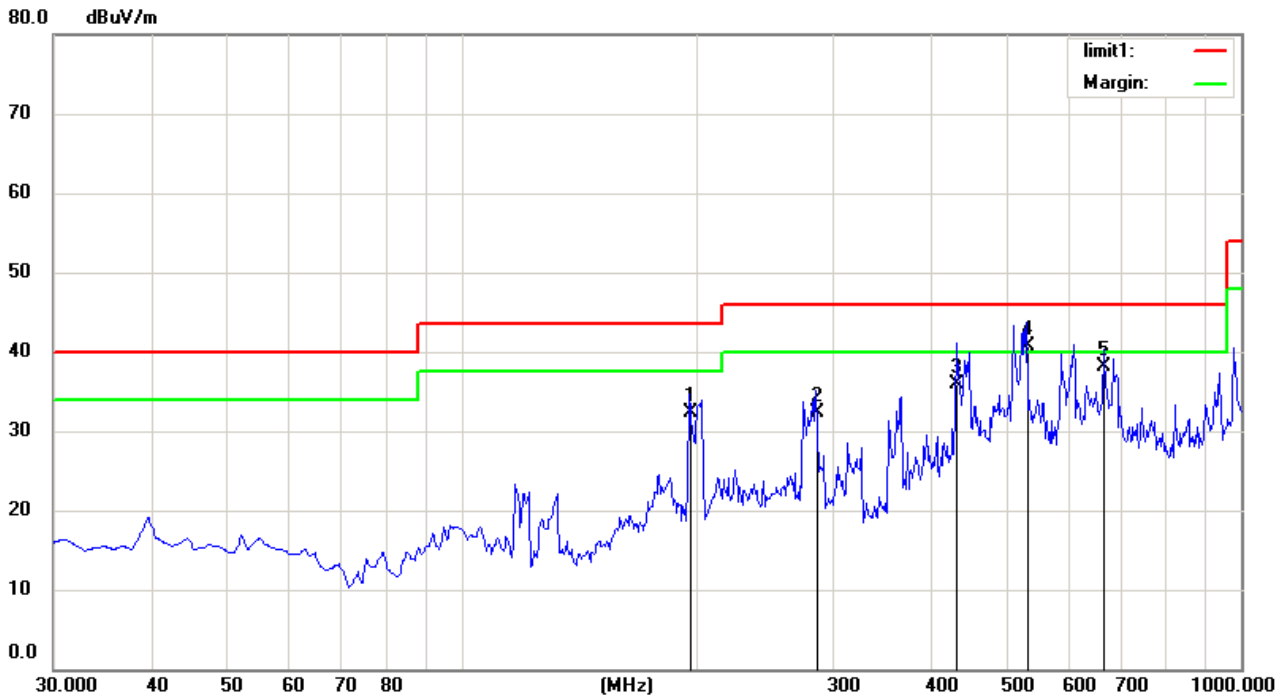

Site Chamber #1

Polarization: **Horizontal**

Temperature: 26

Limit: (RE)FCC PART 15 class B 3m

Power: AC 120V/60Hz

Humidity: 55 %

EUT: 7 INCH DIGITAL PHOTO FRAME

M/N: DF-F7S

Mode: SD CARD PLAYING

Note: ADS-12G-06 05010GPCU

No.	Mk.	Freq.	Reading Level	Correct Factor	Measurement	Limit	Over	Antenna Height	Table Degree		
		MHz	dBuV	dB	dBuV/m	dBuV/m	dB	Detector	cm	degree	Comment
1		195.8700	46.34	-14.10	32.24	43.50	-11.26	QP			
2		285.1100	43.39	-11.06	32.33	46.00	-13.67	QP			
3		431.5800	44.29	-8.31	35.98	46.00	-10.02	QP			
4	*	530.5200	47.65	-6.95	40.70	46.00	-5.30	QP			
5		667.2900	43.08	-4.93	38.15	46.00	-7.85	QP			

*:Maximum data x:Over limit !:over margin

Operator:

Radiated Emission Measurement

File :DF-F7S

Data :#6

Date: 2009/07/03

Time: 16:40:53

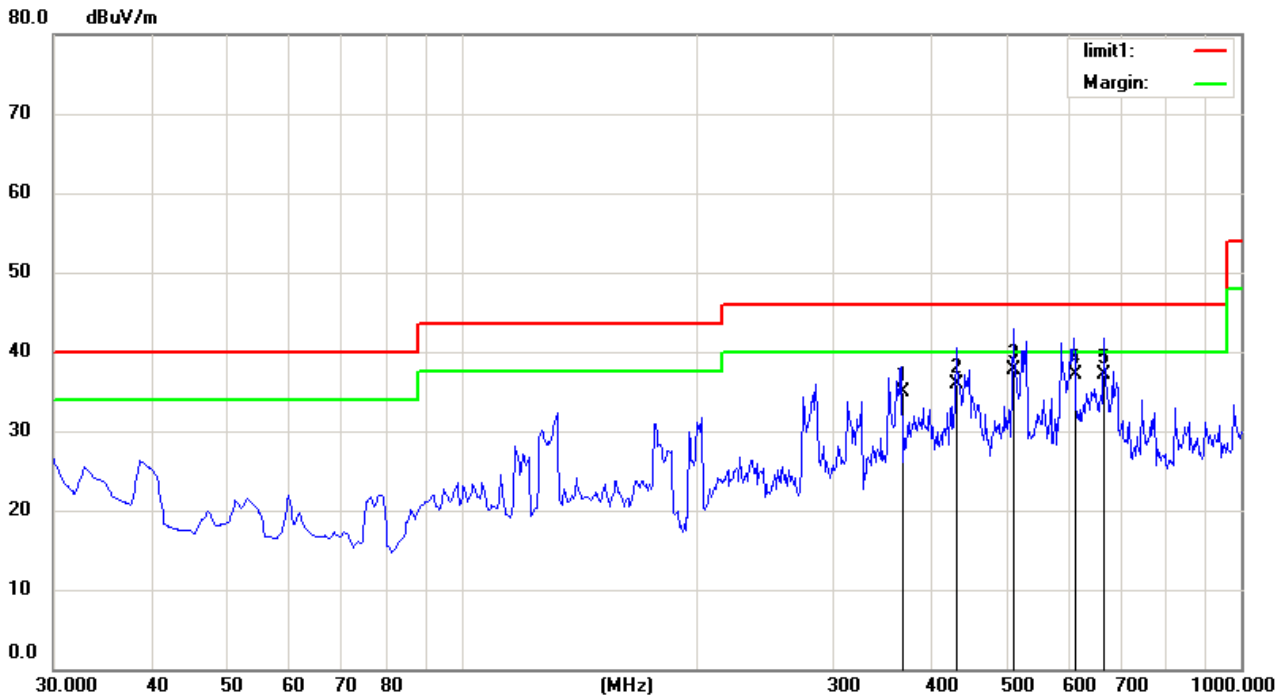

Site Chamber #1

Polarization: **Vertical**

Temperature: 26

Limit: (RE)FCC PART 15 class B 3m

Power: AC 120V/60Hz

Humidity: 55 %

EUT: 7 INCH DIGITAL PHOTO FRAME

M/N: DF-F7S

Mode: SD CARD PLAYING

Note: ADS-12G-06 05010GPCU

No.	Mk.	Freq.	Reading Level	Correct Factor	Measurement	Limit	Over	Antenna Height	Table Degree	Comment
		MHz	dBuV	dB	dBuV/m	dBuV/m	dB	cm	degree	
1		367.5600	44.39	-9.55	34.84	46.00	-11.16	QP		
2		431.5800	44.19	-8.31	35.88	46.00	-10.12	QP		
3	*	510.1500	44.85	-7.06	37.79	46.00	-8.21	QP		
4		612.0000	42.52	-5.32	37.20	46.00	-8.80	QP		
5		667.2900	42.01	-4.93	37.08	46.00	-8.92	QP		

*:Maximum data x:Over limit !:over margin

Operator:

Radiated Emission Measurement

File :DF-F7S

Data :#7

Date: 2009-7-6

Time: 9:06:09

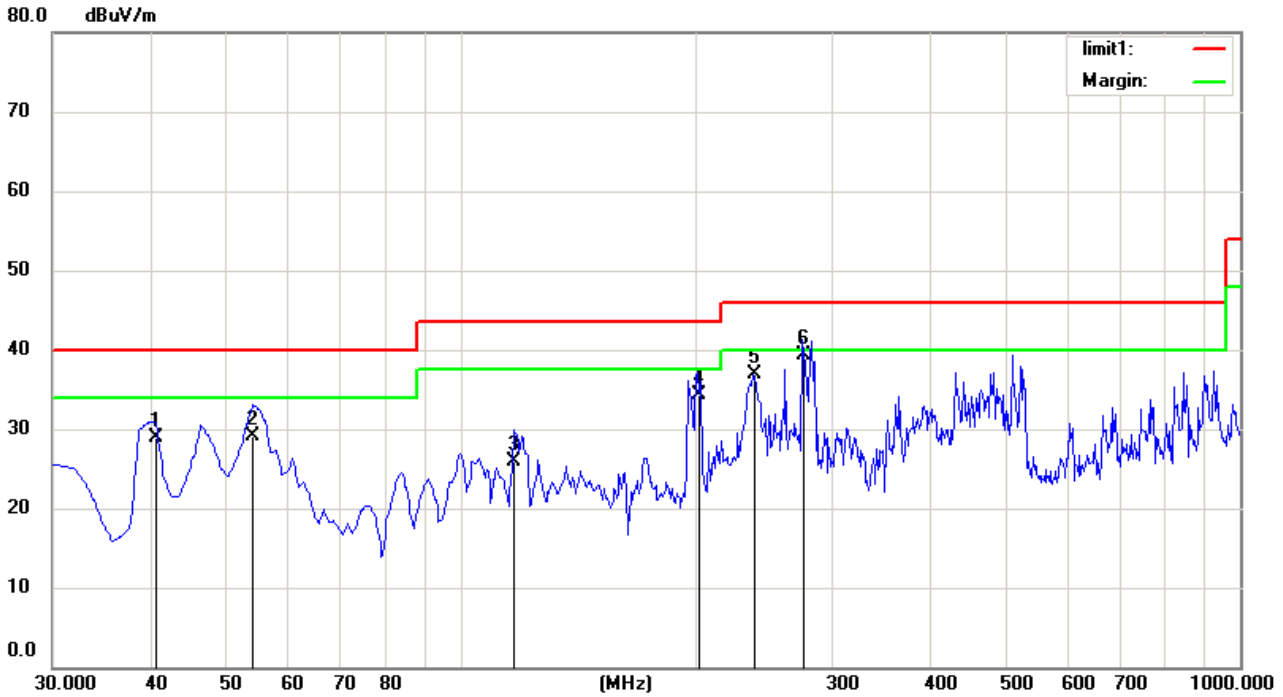

Site Chamber #1

Polarization: **Horizontal**

Temperature: 26

Limit: (RE)FCC PART 15 class B 3m

Power: AC 120V/60Hz

Humidity: 55 %

EUT: 7 INCH DIGITAL PHOTO FRAME

M/N: DF-F7S

Mode: CONNECT TO PC

Note: ADS-12G-06 05010GPCU

No.	Mk.	Freq.	Reading Level	Correct Factor	Measurement	Limit	Over	Antenna Height	Table Degree	
		MHz	dBuV	dB	dBuV/m	dBuV/m	dB	Detector	cm	degree
1		40.6700	42.99	-14.13	28.86	40.00	-11.14	QP		
2		54.2500	43.71	-14.59	29.12	40.00	-10.88	QP		
3		117.3000	42.39	-16.49	25.90	43.50	-17.60	QP		
4		201.6900	48.15	-13.85	34.30	43.50	-9.20	QP		
5		237.5800	49.08	-12.18	36.90	46.00	-9.10	QP		
6	*	274.4400	50.90	-11.50	39.40	46.00	-6.60	QP		

*:Maximum data x:Over limit !:over margin

Operator:

Radiated Emission Measurement

File :DF-F7S

Data :#8

Date: 2009-7-6

Time: 9:10:51

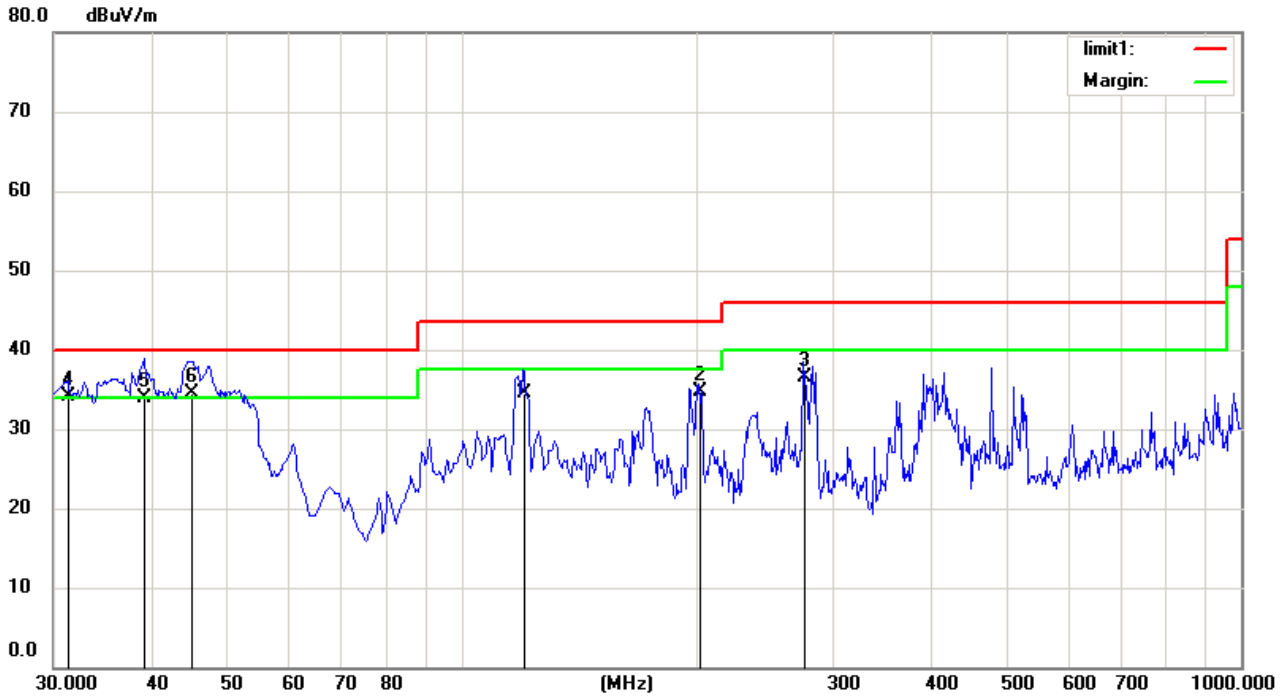

Site Chamber #1

Polarization: **Vertical**

Temperature: 26

Limit: (RE)FCC PART 15 class B 3m

Power: AC 120V/60Hz

Humidity: 55 %

EUT: 7 INCH DIGITAL PHOTO FRAME

M/N: DF-F7S

Mode:CONNECT TO PC

Note: ADS-12G-06 05010GPCU

No.	Mk.	Freq. MHz	Reading Level dBuV	Correct Factor dB	Measure- ment dBuV/m	Limit dBuV/m	Over dB	Antenna Height cm	Table Degree	Detector	Comment
1		120.2100	51.57	-17.00	34.57	43.50	-8.93			QP	
2		201.6900	48.60	-13.85	34.75	43.50	-8.75			QP	
3		274.4400	47.91	-11.50	36.41	46.00	-9.59			QP	
4	!	31.2892	49.06	-15.01	34.05	40.00	-5.95			QP	
5		39.2991	48.01	-14.19	33.82	40.00	-6.18			QP	
6	*	45.0583	48.62	-14.13	34.49	40.00	-5.51			QP	

*:Maximum data x:Over limit !:over margin

Operator:

Adapter **ZDA050200US** used for test.

Radiated Emission Measurement

File :DF-F7S

Data :#1

Date: 09/07/04/

Time: 9/48/45

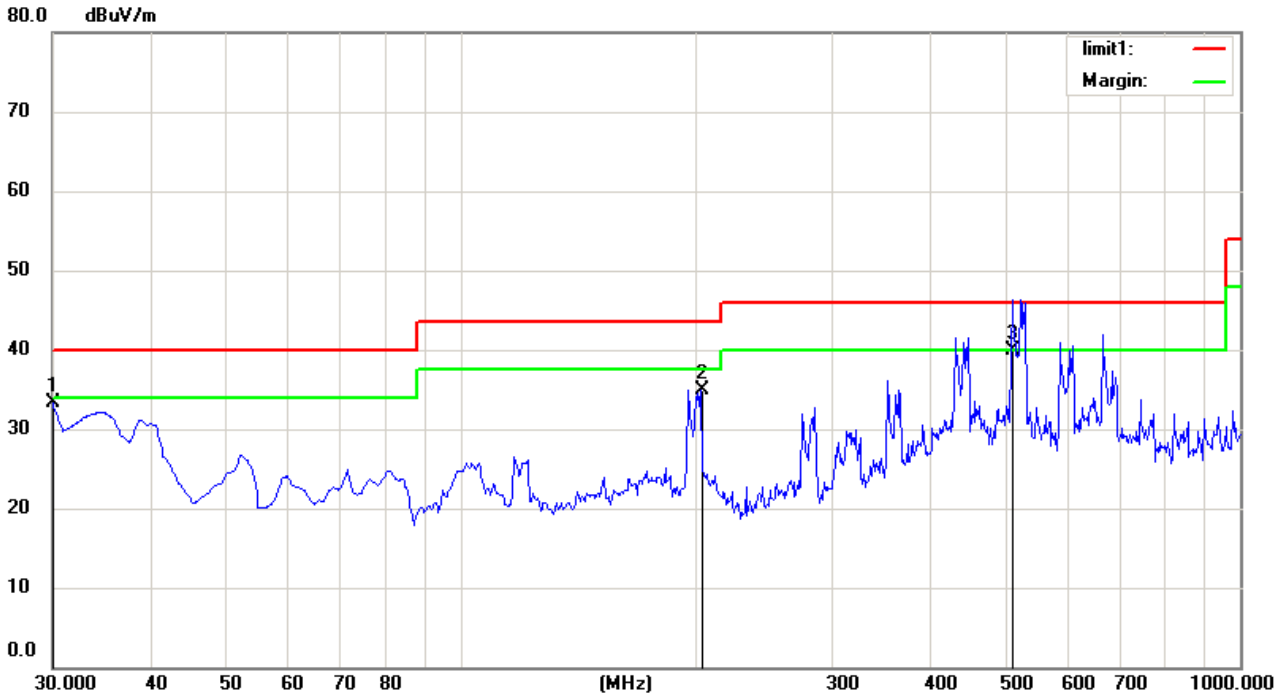

Site Chamber #1

Polarization: **Vertical**

Temperature: 26

Limit: (RE)FCC PART 15 class B 3m

Power: AC 120V/60Hz

Humidity: 55 %

EUT: 7 INCH DIGITAL PHOTO FRAME

M/N: DF-F7S

Mode: Memorying

Note: ZDA050200US

No.	Mk.	Freq. MHz	Reading Level dBuV	Correct Factor dB	Measure- ment dBuV/m	Limit dBuV/m	Over dB	Antenna Height cm	Table Degree degree	Comment
1		30.0000	48.39	-15.15	33.24	40.00	-6.76	QP		
2		203.6300	48.64	-13.82	34.82	43.50	-8.68	QP		
3	*	510.1500	47.00	-7.06	39.94	46.00	-6.06	QP		

*:Maximum data x:Over limit !:over margin

Operator:

Radiated Emission Measurement

File :DF-F7S

Data :#2

Date: 09/07/04/

Time: 9/52/01

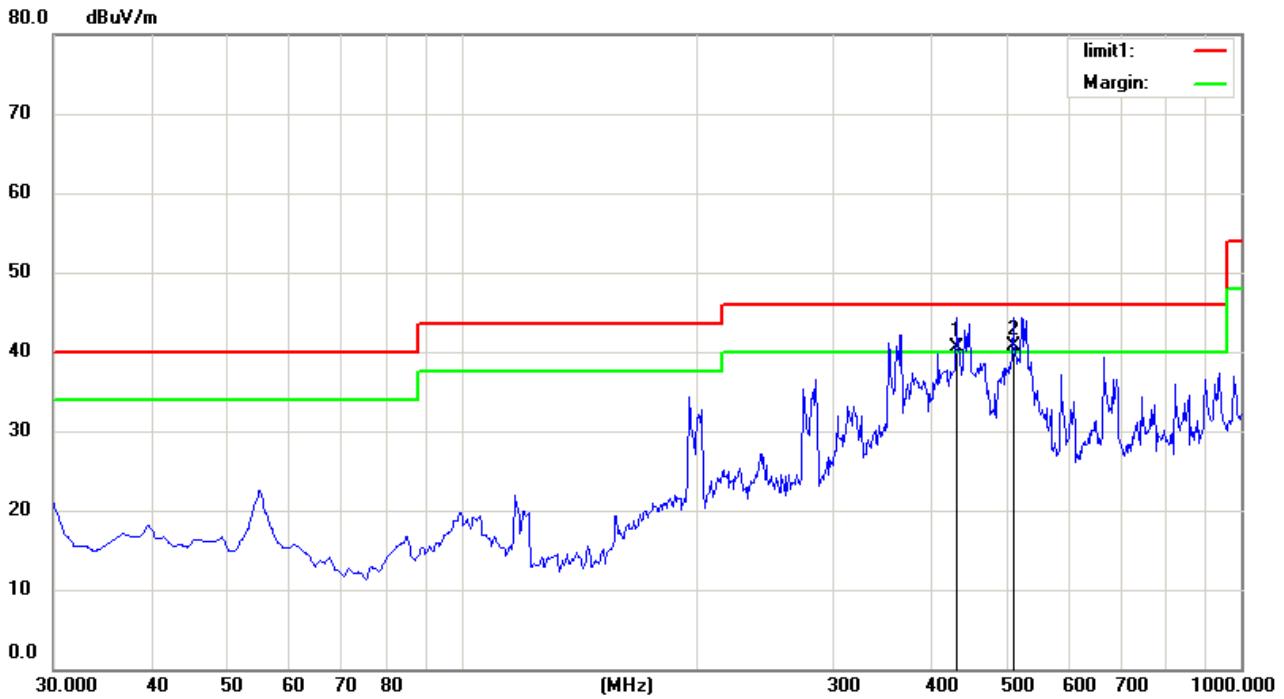

Site Chamber #1

Polarization: **Horizontal**

Temperature: 26

Limit: (RE)FCC PART 15 class B 3m

Power: AC 120V/60Hz

Humidity: 55 %

EUT: 7 INCH DIGITAL PHOTO FRAME

M/N: DF-F7S

Mode: Memorying

Note: ZDA050200US

No.	Mk.	Freq. MHz	Reading Level dBuV	Correct Factor dB	Measure- ment dBuV/m	Limit dBuV/m	Over dB	Antenna Height cm	Table Degree degree	Comment
1	!	431.5800	48.90	-8.31	40.59	46.00	-5.41	QP		
2	*	510.1500	47.70	-7.06	40.64	46.00	-5.36	QP		

*:Maximum data x:Over limit !:over margin

Operator:

Radiated Emission Measurement

File :DF-F7S

Data :#3

Date: 09/07/04/

Time: 20/05/02

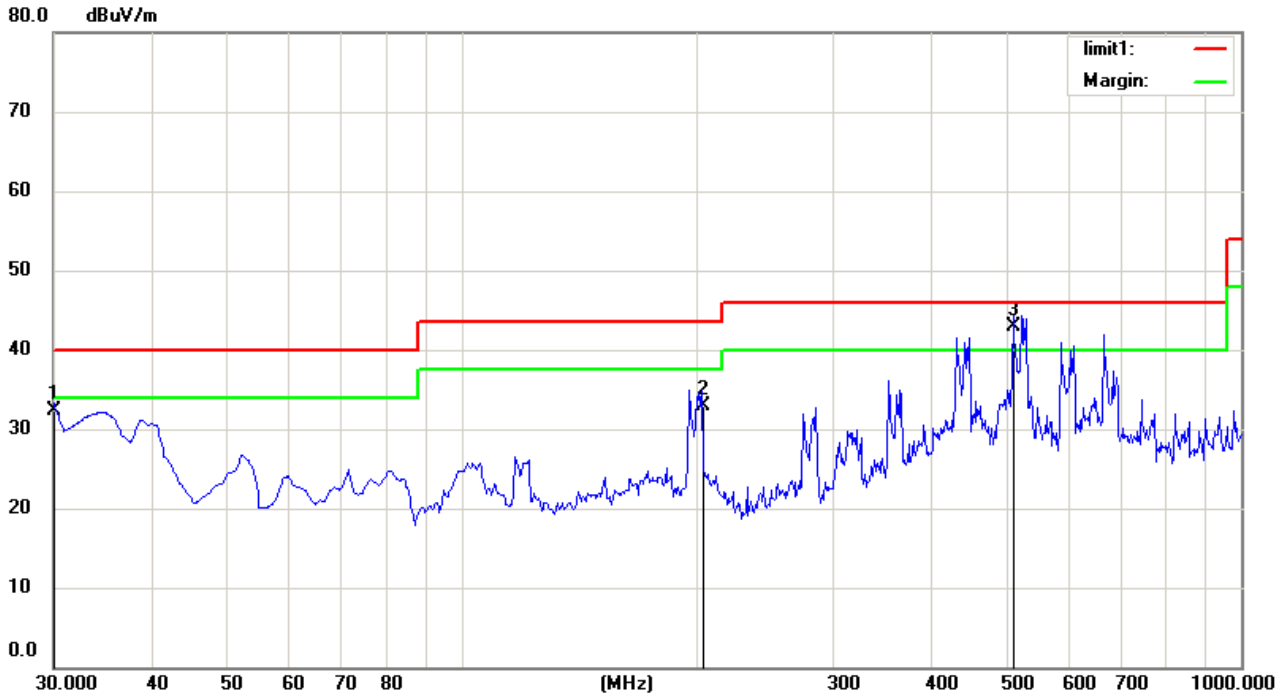

Site Chamber #1

Polarization: **Vertical**

Temperature: 26

Limit: (RE)FCC PART 15 class B 3m

Power: AC 120V/60Hz

Humidity: 55 %

EUT: 7 INCH DIGITAL PHOTO FRAME

M/N: DF-F7S

Mode: USB PLAYING

Note: ZDA050200US

No.	Mk.	Freq.	Reading Level	Correct Factor	Measurement	Limit	Over	Antenna Height	Table Degree		
		MHz	dBuV	dB	dBuV/m	dBuV/m	dB	Detector	cm	degree	Comment
1		30.0000	47.39	-15.15	32.24	40.00	-7.76	QP			
2		203.6300	46.64	-13.82	32.82	43.50	-10.68	QP			
3	*	510.1500	50.06	-7.06	43.00	46.00	-3.00	QP			

*:Maximum data x:Over limit !:over margin

Operator:

Radiated Emission Measurement

File :DF-F7S

Data :#4

Date: 09/07/04/

Time: 20/11/35

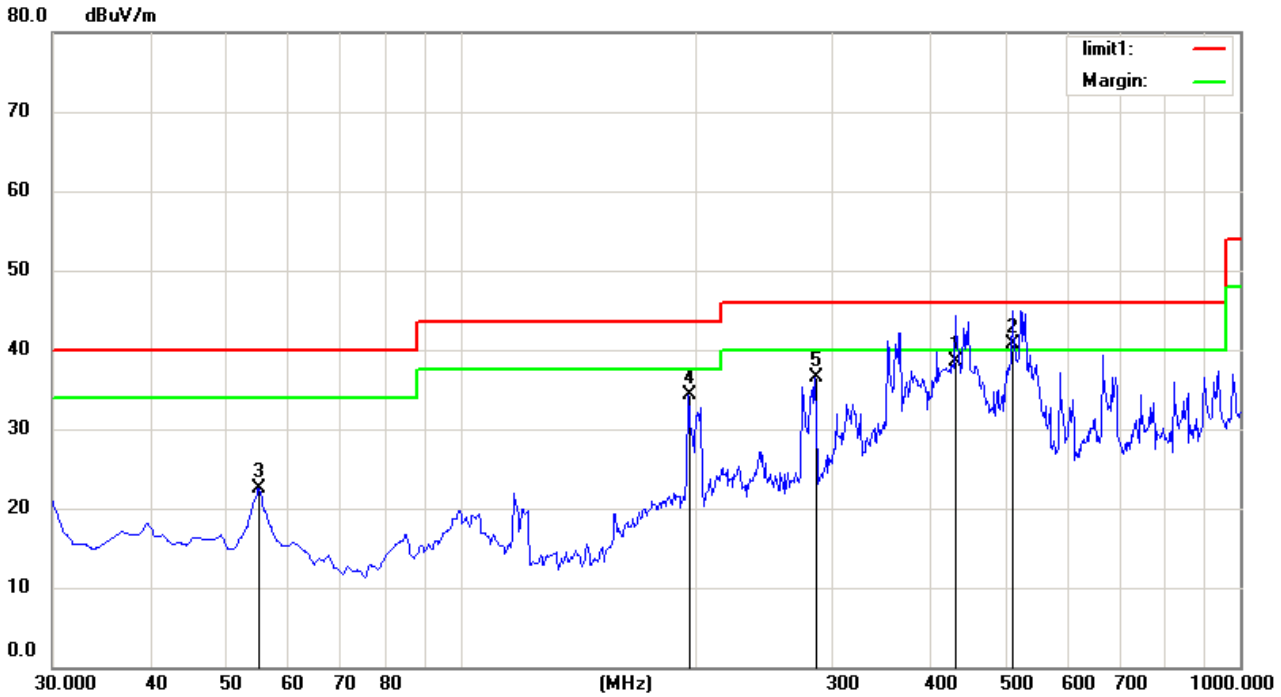

Site Chamber #1

Polarization: **Horizontal**

Temperature: 26

Limit: (RE)FCC PART 15 class B 3m

Power: AC 120V/60Hz

Humidity: 55 %

EUT: 7 INCH DIGITAL PHOTO FRAME

M/N: DF-F7S

Mode: USB PLAYING

Note: ZDA050200US

No.	Mk.	Freq. MHz	Reading Level dBuV	Correct Factor dB	Measure- ment dBuV/m	Limit dBuV/m	Over dB	Antenna Height cm	Table Degree degree	Comment
1		431.5800	46.90	-8.31	38.59	46.00	-7.41	QP		
2	*	510.1500	47.80	-7.06	40.74	46.00	-5.26	QP		
3		55.2200	37.11	-14.63	22.48	40.00	-17.52	QP		
4		195.8700	48.35	-14.10	34.25	43.50	-9.25	QP		
5		285.1100	47.59	-11.06	36.53	46.00	-9.47	QP		

*:Maximum data x:Over limit !:over margin

Operator:

Radiated Emission Measurement

File :DF-F7S

Data :#5

Date: 09/07/04/

Time: 20/15/45

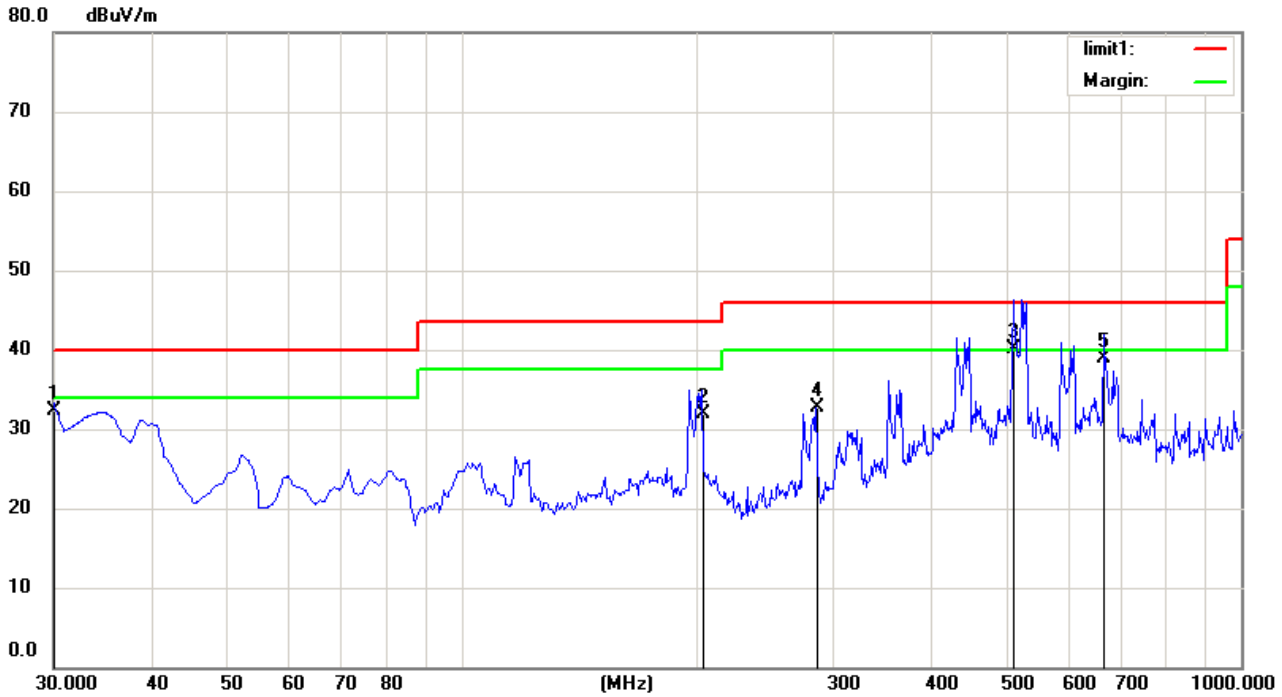

Site Chamber #1

Polarization: **Vertical**

Temperature: 26

Limit: (RE)FCC PART 15 class B 3m

Power: AC 120V/60Hz

Humidity: 55 %

EUT: 7 INCH DIGITAL PHOTO FRAME

M/N: DF-F7S

Mode:SD CARD PLAYING

Note: ZDA050200US

No.	Mk.	Freq.	Reading Level	Correct Factor	Measurement	Limit	Over	Antenna Height	Table Degree	
		MHz	dBuV	dB	dBuV/m	dBuV/m	dB	cm	degree	Comment
1		30.0000	47.39	-15.15	32.24	40.00	-7.76	QP		
2		203.6300	45.64	-13.82	31.82	43.50	-11.68	QP		
3	*	510.1500	47.10	-7.06	40.04	46.00	-5.96	QP		
4		285.1100	43.71	-11.06	32.65	46.00	-13.35	QP		
5		667.2900	43.92	-4.93	38.99	46.00	-7.01	QP		

*:Maximum data x:Over limit !:over margin

Operator:

Radiated Emission Measurement

File :DF-F7S

Data :#6

Date: 09/07/04/

Time: 20/19/33

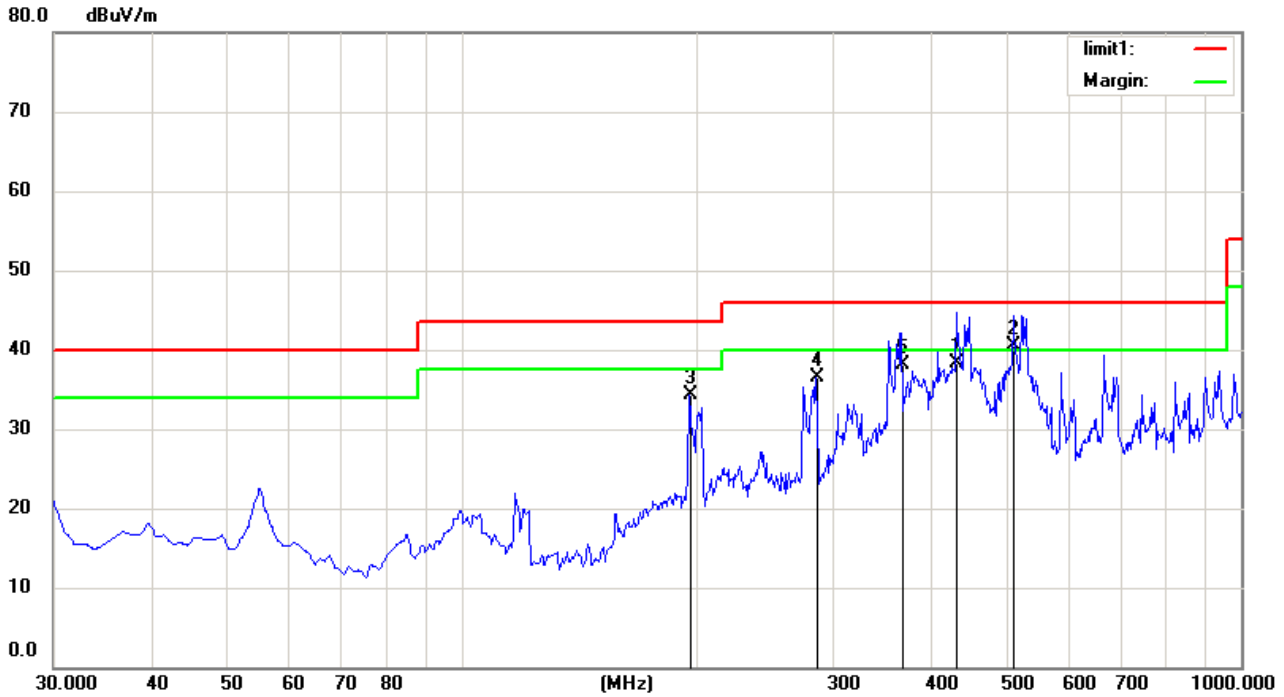

Site Chamber #1

Polarization: **Horizontal**

Temperature: 26

Limit: (RE)FCC PART 15 class B 3m

Power: AC 120V/60Hz

Humidity: 55 %

EUT: 7 INCH DIGITAL PHOTO FRAME

M/N: DF-F7S

Mode:SD CARD PLAYING

Note: ZDA050200US

No.	Mk.	Freq. MHz	Reading Level dBuV	Correct Factor dB	Measure- ment dBuV/m	Limit dBuV/m	Over dB	Antenna Height cm	Table Degree degree	Comment
1		431.5800	46.55	-8.31	38.24	46.00	-7.76	QP		
2	*	510.1500	47.56	-7.06	40.50	46.00	-5.50	QP		
3		195.8700	48.35	-14.10	34.25	43.50	-9.25	QP		
4		285.1100	47.59	-11.06	36.53	46.00	-9.47	QP		
5		367.5600	47.64	-9.55	38.09	46.00	-7.91	QP		

*:Maximum data x:Over limit !:over margin

Operator:

Radiated Emission Measurement

File :DF-F7S

Data :#7

Date: 2009-7-6

Time: 10:57:21

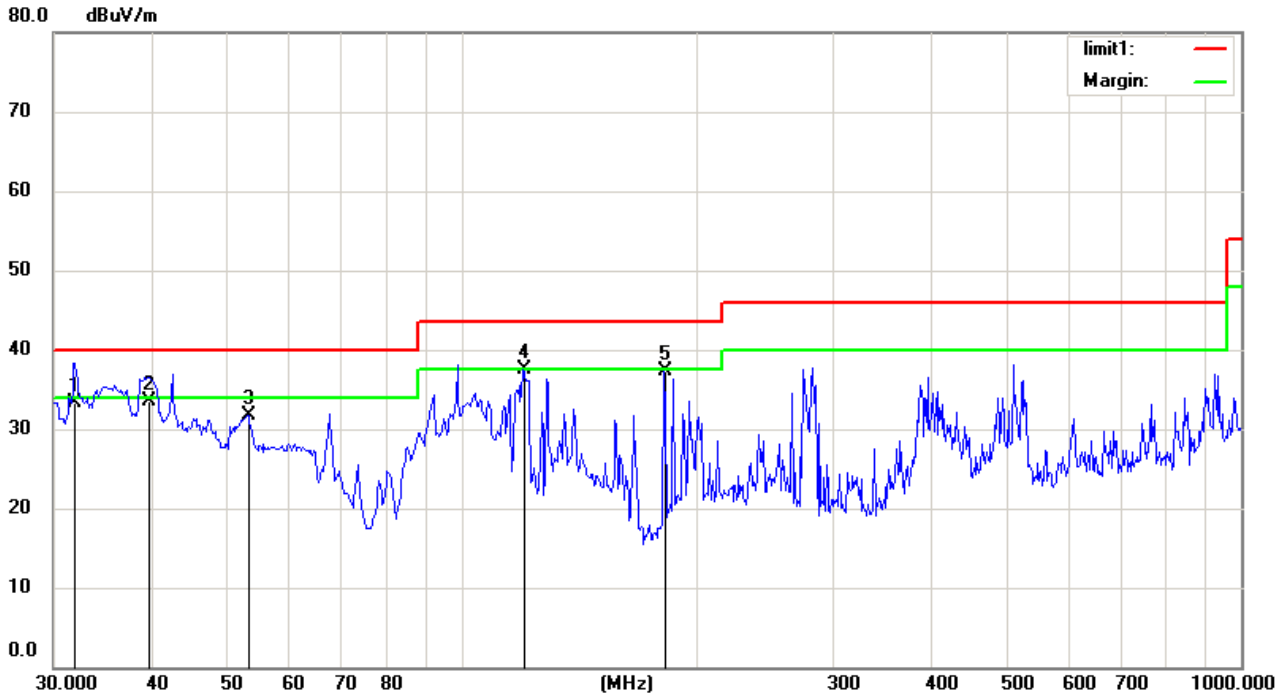

Site Chamber #1

Polarization: **Vertical**

Temperature: 26

Limit: (RE)FCC PART 15 class B 3m

Power: AC 120V/60Hz

Humidity: 55 %

EUT: 7 INCH DIGITAL PHOTO FRAME

M/N: DF-F7S

Mode:CONNECT TO PC

Note: ZDA050200US

No.	Mk.	Freq. MHz	Reading Level dBuV	Correct Factor dB	Measure- ment dBuV/m	Limit dBuV/m	Over dB	Antenna Height cm	Table Degree degree	Comment
1		31.9400	48.32	-14.95	33.37	40.00	-6.63	QP		
2		39.7000	47.74	-14.15	33.59	40.00	-6.41	QP		
3		53.2800	46.29	-14.55	31.74	40.00	-8.26	QP		
4	*	120.2100	54.41	-17.00	37.41	43.50	-6.09	QP		
5		182.2900	52.72	-15.44	37.28	43.50	-6.22	QP		

*:Maximum data x:Over limit !:over margin

Operator:

Radiated Emission Measurement

File :DF-F7S

Data :#8

Date: 2009-7-6

Time: 11:01:30

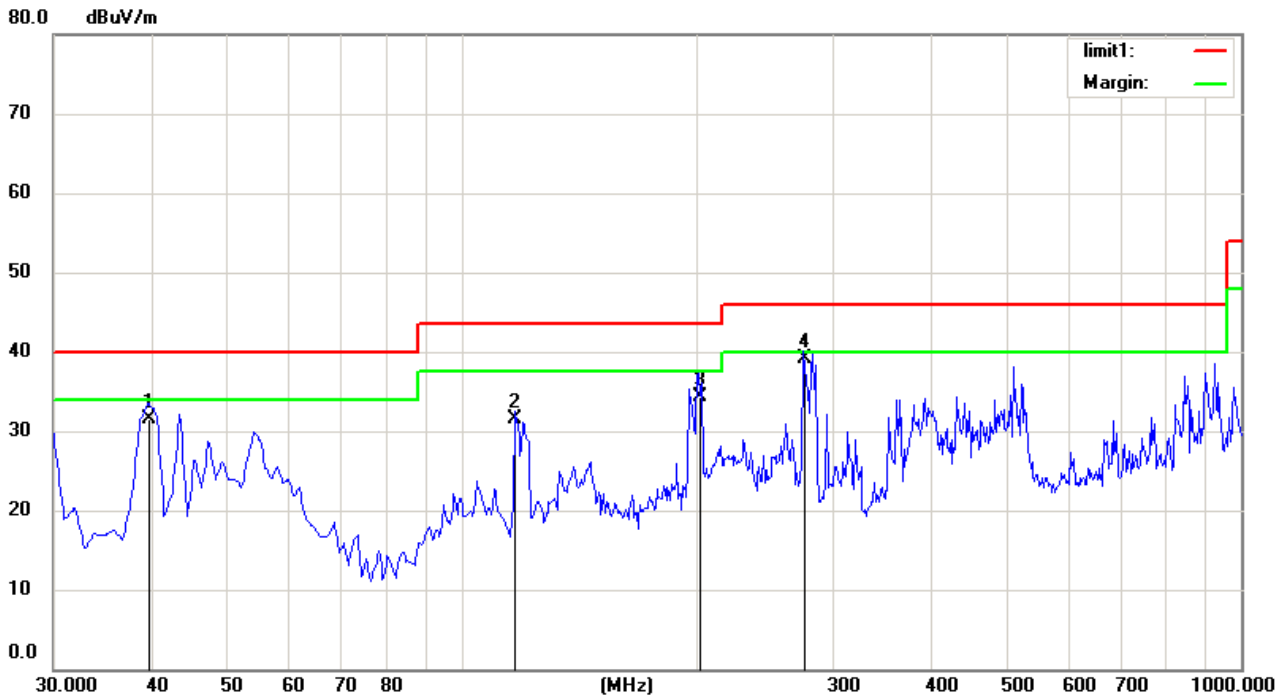

Site Chamber #1

Polarization: **Horizontal**

Temperature: 26

Limit: (RE)FCC PART 15 class B 3m

Power: AC 120V/60Hz

Humidity: 55 %

EUT: 7 INCH DIGITAL PHOTO FRAME

M/N: DF-F7S

Mode: CONNECT TO PC

Note: ZDA050200US

No.	Mk.	Freq. MHz	Reading Level dBuV	Correct Factor dB	Measure- ment dBuV/m	Limit dBuV/m	Over dB	Antenna Height cm	Table Degree degree	Comment
1		39.7000	45.62	-14.15	31.47	40.00	-8.53	QP		
2		117.3000	47.98	-16.49	31.49	43.50	-12.01	QP		
3		201.6900	48.11	-13.85	34.26	43.50	-9.24	QP		
4	*	274.4400	50.60	-11.50	39.10	46.00	-6.90	QP		

*:Maximum data x:Over limit !:over margin

Operator:

Adapter XKD-C2000IC5.0-12W used for test.

Radiated Emission Measurement

File :DF-F7S

Data :#1

Date: 09/07/04/

Time: 9/42/11



Site Chamber #1

Polarization: **Horizontal**

Temperature: 26

Limit: (RE)FCC PART 15 class B 3m

Power: AC 120V/60Hz

Humidity: 55 %

EUT: 7 INCH DIGITAL PHOTO FRAME

M/N: DF-F7S

Mode: Memorying

Note: XKD-C2000IC5.0-12W

No.	Mk.	Freq. MHz	Reading Level dBuV	Correct Factor dB	Measure- ment dBuV/m	Limit dBuV/m	Over dB	Antenna Height cm	Table Degree	Detector	Comment
1		431.5800	47.55	-8.31	39.24	46.00	-6.76			QP	
2		55.2200	39.45	-14.63	24.82	40.00	-15.18			QP	
3		195.8700	46.82	-14.10	32.72	43.50	-10.78			QP	
4		285.1100	47.36	-11.06	36.30	46.00	-9.70			QP	
5	*	510.1500	46.81	-7.06	39.75	46.00	-6.25			QP	

*:Maximum data x:Over limit !:over margin

Operator:

Radiated Emission Measurement

File :DF-F7S

Data :#2

Date: 09/07/04/

Time: 9/45/09

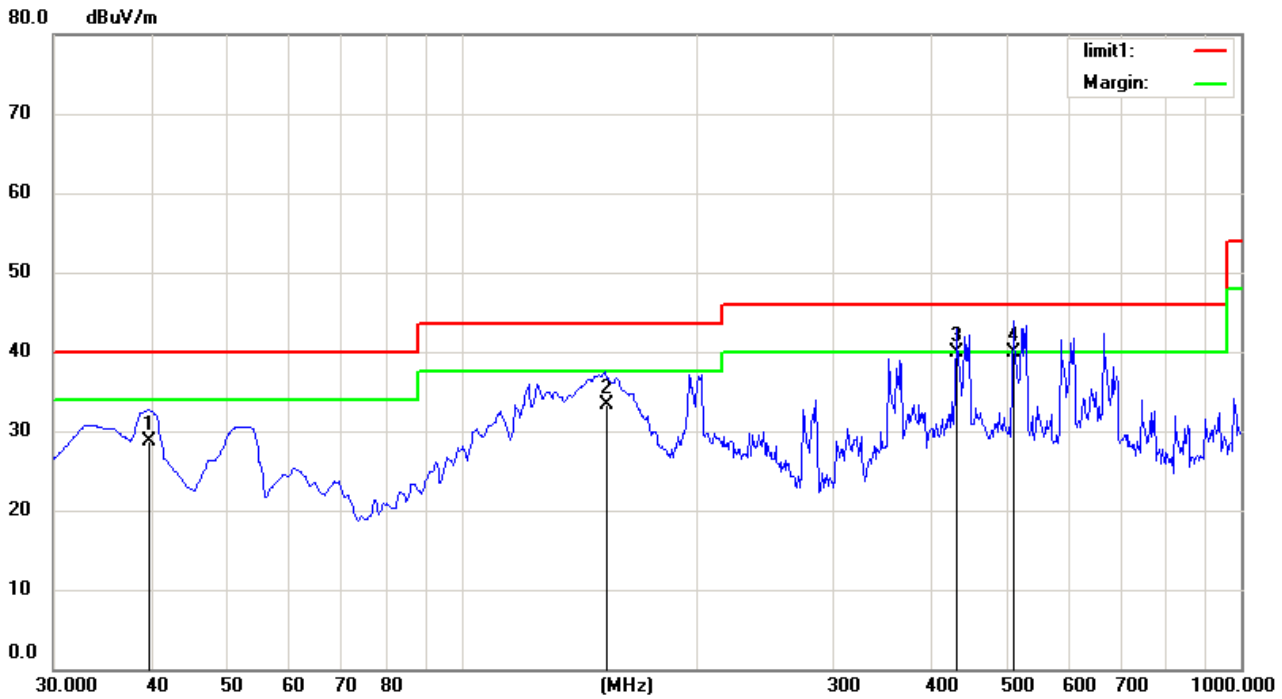

Site Chamber #1

Polarization: **Vertical**

Temperature: 26

Limit: (RE)FCC PART 15 class B 3m

Power: AC 120V/60Hz

Humidity: 55 %

EUT: 7 INCH DIGITAL PHOTO FRAME

M/N: DF-F7S

Mode: Memorying

Note: XKD-C2000IC5.0-12W

No.	Mk.	Freq.	Reading Level	Correct Factor	Measurement	Limit	Over	Antenna Height	Table Degree	
		MHz	dBuV	dB	dBuV/m	dBuV/m	dB	cm	degree	Comment
1		39.7000	42.85	-14.15	28.70	40.00	-11.30	QP		
2		153.2004	51.81	-18.41	33.40	43.50	-10.10	QP		
3	*	431.5800	48.15	-8.31	39.84	46.00	-6.16	QP		
4		510.1500	46.90	-7.06	39.84	46.00	-6.16	QP		

*:Maximum data x:Over limit !:over margin

Operator:

Radiated Emission Measurement

File :DF-F7S

Data :#3

Date: 09/07/04/

Time: 19/40/12

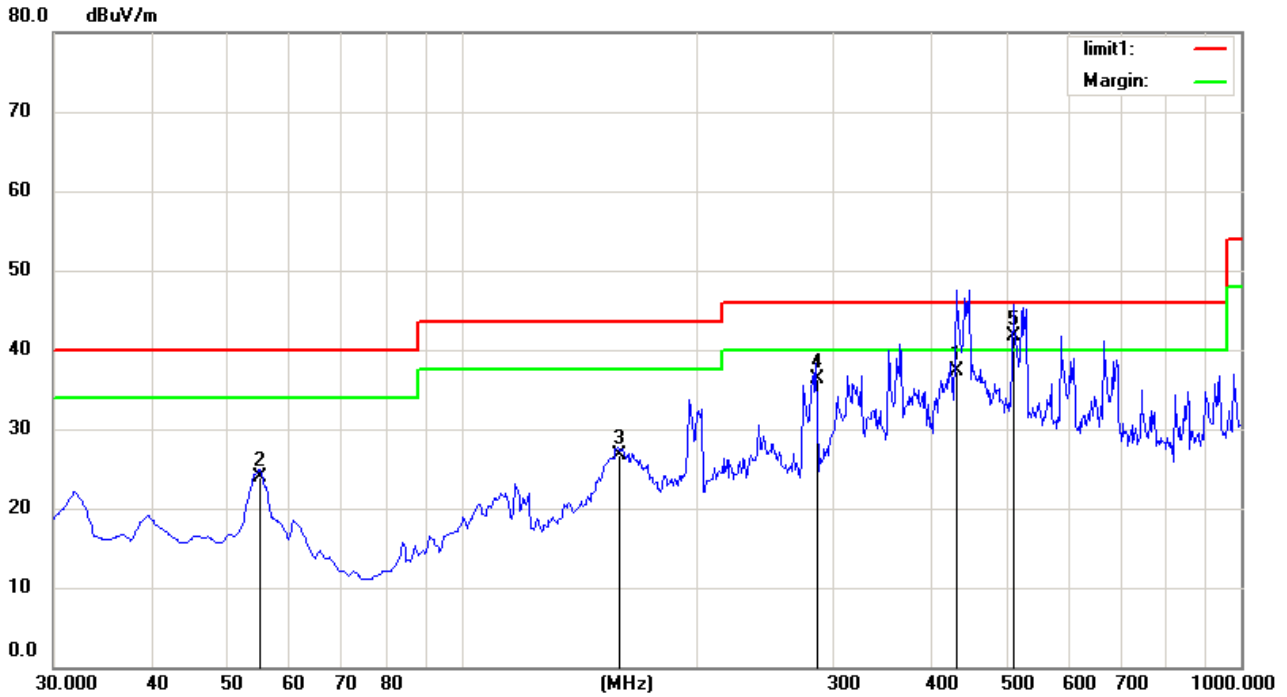

Site Chamber #1

Polarization: **Horizontal**

Temperature: 26

Limit: (RE)FCC PART 15 class B 3m

Power: AC 120V/60Hz

Humidity: 55 %

EUT: 7 INCH DIGITAL PHOTO FRAME

M/N: DF-F7S

Mode: USB PLAYING

Note: XKD-C2000IC5.0-12W

No.	Mk.	Freq.	Reading Level	Correct Factor	Measurement	Limit	Over	Antenna Height	Table Degree		
		MHz	dBuV	dB	dBuV/m	dBuV/m	dB	Detector	cm	degree	Comment
1		431.5800	45.65	-8.31	37.34	46.00	-8.66	QP			
2		55.2200	38.45	-14.63	23.82	40.00	-16.18	QP			
3		159.0100	44.47	-17.86	26.61	43.50	-16.89	QP			
4		285.1100	47.36	-11.06	36.30	46.00	-9.70	QP			
5	*	510.1500	48.81	-7.06	41.75	46.00	-4.25	QP			

*:Maximum data x:Over limit !:over margin

Operator:

Radiated Emission Measurement

File :DF-F7S

Data :#4

Date: 09/07/04/

Time: 19/45/44

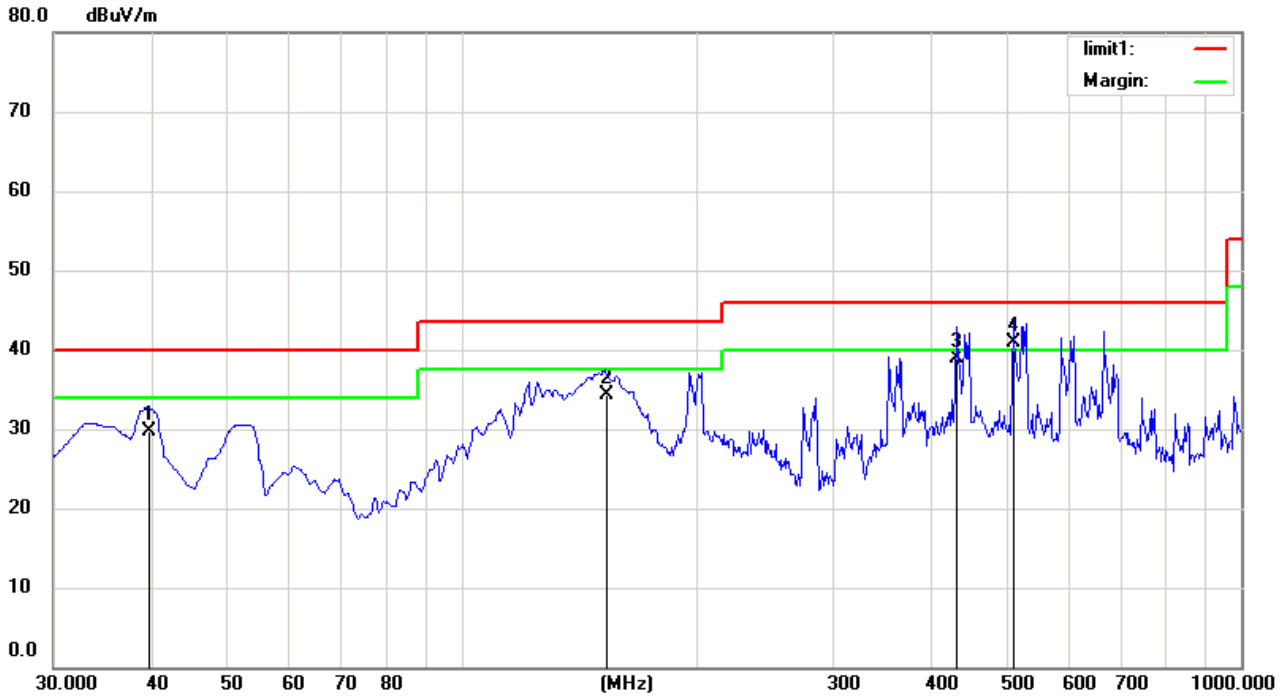

Site Chamber #1

Polarization: **Vertical**

Temperature: 26

Limit: (RE)FCC PART 15 class B 3m

Power: AC 120V/60Hz

Humidity: 55 %

EUT: 7 INCH DIGITAL PHOTO FRAME

M/N: DF-F7S

Mode:USB PLAYING

Note: XKD-C2000IC5.0-12W

No.	Mk.	Freq.	Reading Level	Correct Factor	Measurement	Limit	Over	Antenna Height	Table Degree	
		MHz	dBuV	dB	dBuV/m	dBuV/m	dB	Detector	cm	degree
1		39.7000	43.85	-14.15	29.70	40.00	-10.30	QP		
2		153.2004	52.81	-18.41	34.40	43.50	-9.10	QP		
3		431.5800	47.15	-8.31	38.84	46.00	-7.16	QP		
4	*	510.1500	47.90	-7.06	40.84	46.00	-5.16	QP		

*:Maximum data x:Over limit !:over margin

Operator:

Radiated Emission Measurement

File :DF-F7S

Data :#5

Date: 09/07/04/

Time: 19/52/11

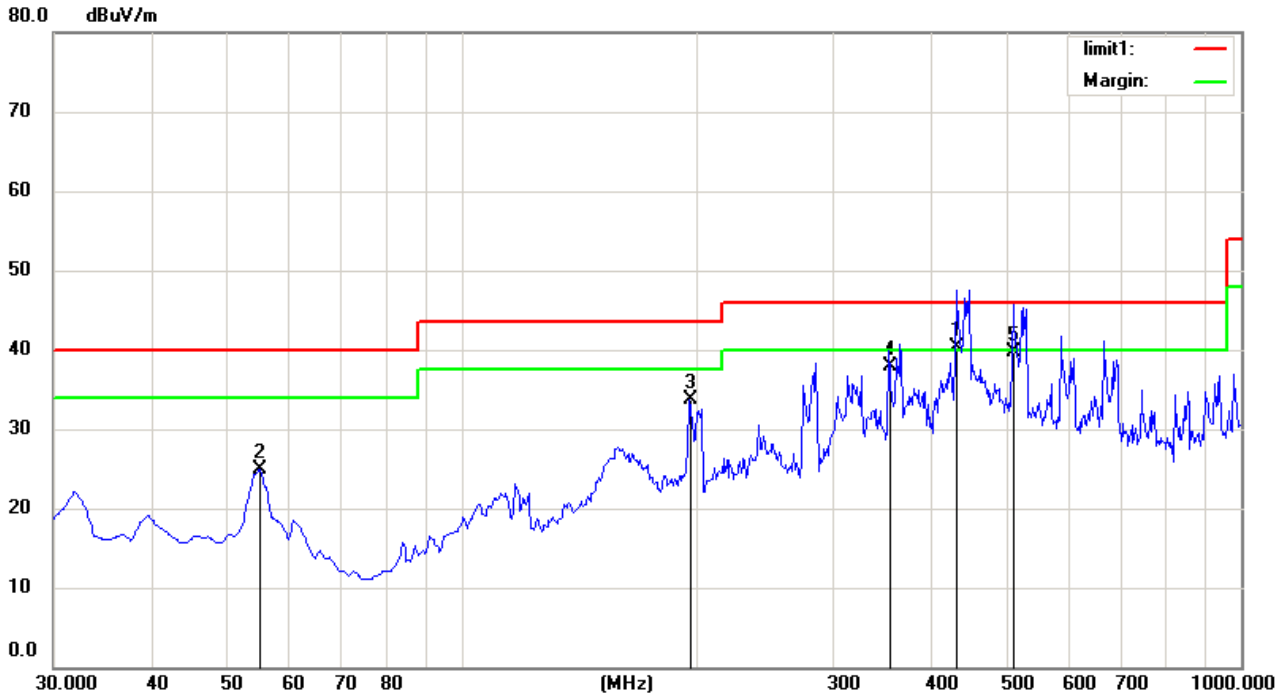

Site Chamber #1

Polarization: **Horizontal**

Temperature: 26

Limit: (RE)FCC PART 15 class B 3m

Power: AC 120V/60Hz

Humidity: 55 %

EUT: 7 INCH DIGITAL PHOTO FRAME

M/N: DF-F7S

Mode: SD CARD PLAYING

Note: XKD-C2000IC5.0-12W

No.	Mk.	Freq. MHz	Reading Level dBuV	Correct Factor dB	Measure- ment dBuV/m	Limit dBuV/m	Over dB	Antenna Height cm	Table Degree	Detector	Comment
1	*	431.5800	48.55	-8.31	40.24	46.00	-5.76			QP	
2		55.2200	39.45	-14.63	24.82	40.00	-15.18			QP	
3		195.8700	47.82	-14.10	33.72	43.50	-9.78			QP	
4		353.0100	47.71	-9.73	37.98	46.00	-8.02			QP	
5		510.1500	46.81	-7.06	39.75	46.00	-6.25			QP	

*:Maximum data x:Over limit !:over margin

Operator:

Radiated Emission Measurement

File :DF-F7S

Data :#6

Date: 09/07/04/

Time: 19/58/45

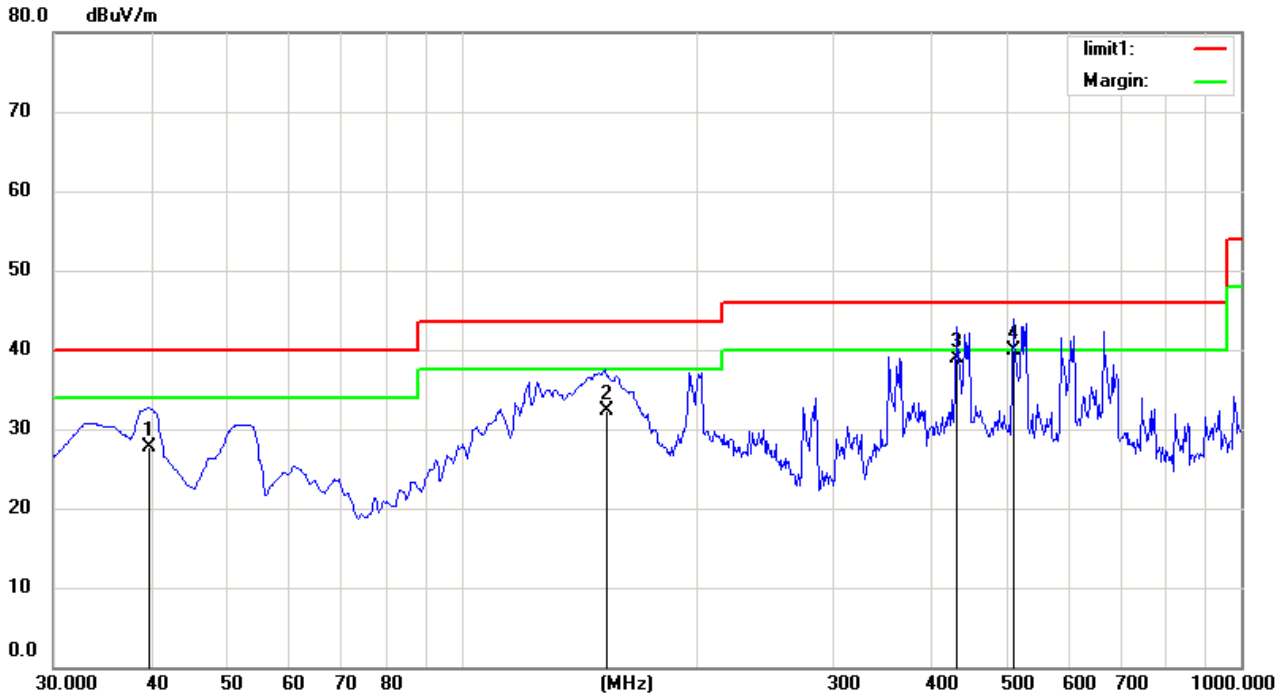

Site Chamber #1

Polarization: **Vertical**

Temperature: 26

Limit: (RE)FCC PART 15 class B 3m

Power: AC 120V/60Hz

Humidity: 55 %

EUT: 7 INCH DIGITAL PHOTO FRAME

M/N: DF-F7S

Mode: SD CARD PLAYING

Note: XKD-C2000IC5.0-12W

No.	Mk.	Freq. MHz	Reading Level dBuV	Correct Factor dB	Measure- ment dBuV/m	Limit dBuV/m	Over dB	Antenna Height cm	Table Degree	Comment
1		39.7000	41.85	-14.15	27.70	40.00	-12.30	QP		
2		153.2004	50.81	-18.41	32.40	43.50	-11.10	QP		
3		431.5800	47.15	-8.31	38.84	46.00	-7.16	QP		
4	*	510.1500	46.90	-7.06	39.84	46.00	-6.16	QP		

*:Maximum data x:Over limit !:over margin

Operator:

Radiated Emission Measurement

File :DF-F7S

Data :#7

Date: 2009-7-6

Time: 10:16:54

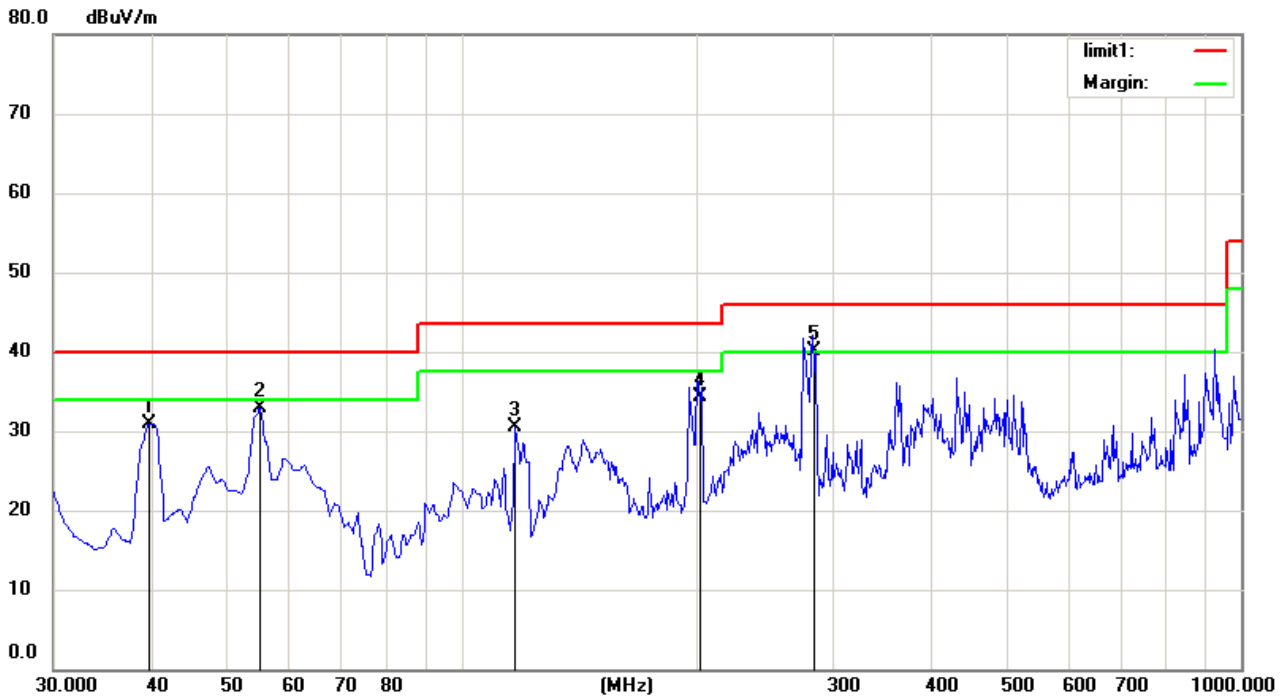

Site Chamber #1

Polarization: **Horizontal**

Temperature: 26

Limit: (RE)FCC PART 15 class B 3m

Power: AC 120V/60Hz

Humidity: 55 %

EUT: 7 INCH DIGITAL PHOTO FRAME

M/N: DF-F7S

Mode: CONNECT TO PC

Note: XKD-C2000IC5.0-12W

No.	Mk.	Freq. MHz	Reading Level dBuV	Correct Factor dB	Measure- ment dBuV/m	Limit dBuV/m	Over dB	Antenna Height cm	Table Degree degree	Comment
1		39.7146	45.06	-14.15	30.91	40.00	-9.09	QP		
2		55.2200	47.45	-14.63	32.82	40.00	-7.18	QP		
3		117.3000	46.92	-16.49	30.43	43.50	-13.07	QP		
4		201.6900	48.25	-13.85	34.40	43.50	-9.10	QP		
5	*	282.2000	51.34	-11.17	40.17	46.00	-5.83	QP		

*:Maximum data x:Over limit !:over margin

Operator:

Radiated Emission Measurement

File :DF-F7S

Data :#8

Date: 2009-7-6

Time: 10:19:10

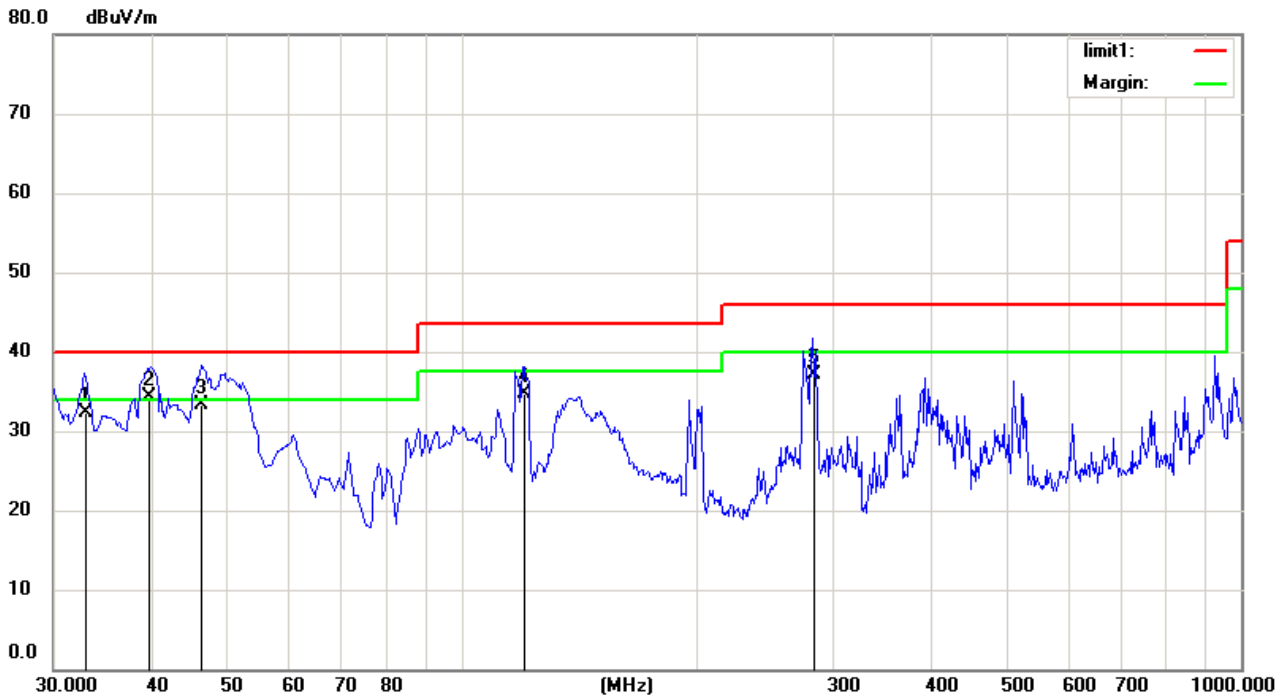

Site Chamber #1

Polarization: **Vertical**

Temperature: 26

Limit: (RE)FCC PART 15 class B 3m

Power: AC 120V/60Hz

Humidity: 55 %

EUT: 7 INCH DIGITAL PHOTO FRAME

M/N: DF-F7S

Mode: CONNECT TO PC

Note: XKD-C2000IC5.0-12W

No.	Mk.	Freq.	Reading Level	Correct Factor	Measurement	Limit	Over	Antenna Height	Table Degree		
		MHz	dBuV	dB	dBuV/m	dBuV/m	dB	Detector	cm	degree	Comment
1		32.9100	47.15	-14.85	32.30	40.00	-7.70	QP			
2	*	39.7000	48.52	-14.15	34.37	40.00	-5.63	QP			
3		46.4900	47.56	-14.22	33.34	40.00	-6.66	QP			
4		120.2100	51.67	-17.00	34.67	43.50	-8.83	QP			
5		282.2000	48.37	-11.17	37.20	46.00	-8.80	QP			

*:Maximum data x:Over limit !:over margin

Operator: