

可以根据LAYOUT时改变接那个3.3V

可以根据LAYOUT时改变接那个3.3V

更改为TO252的封装，利于散热

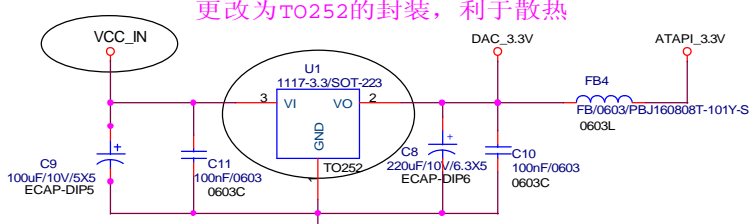

U2, U3要加大散热面积!

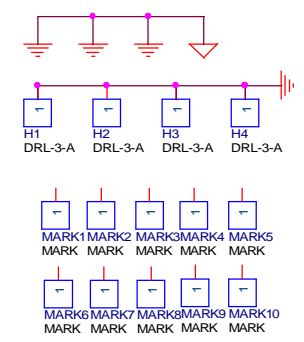
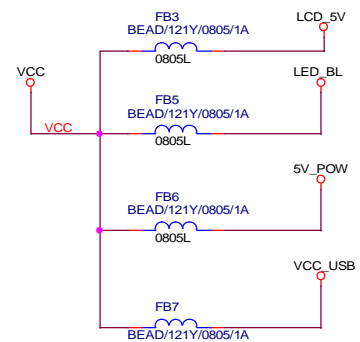
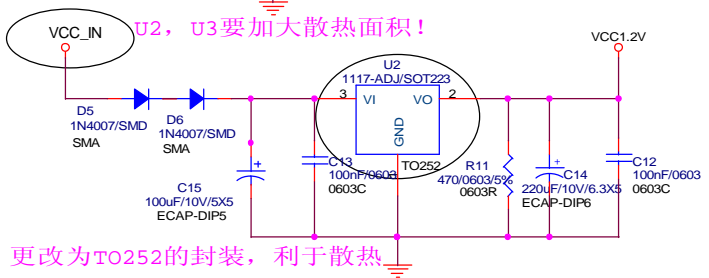

Title		6222D 7DY	
Size	Document Number	Power	
Date:	Tuesday, July 07, 2009	Sheet	2 of 10
			Rev 0.1

Can change to Core\_3.3V or SDRAM\_3.3V  
for Layout convenience

### Power On Configuration:

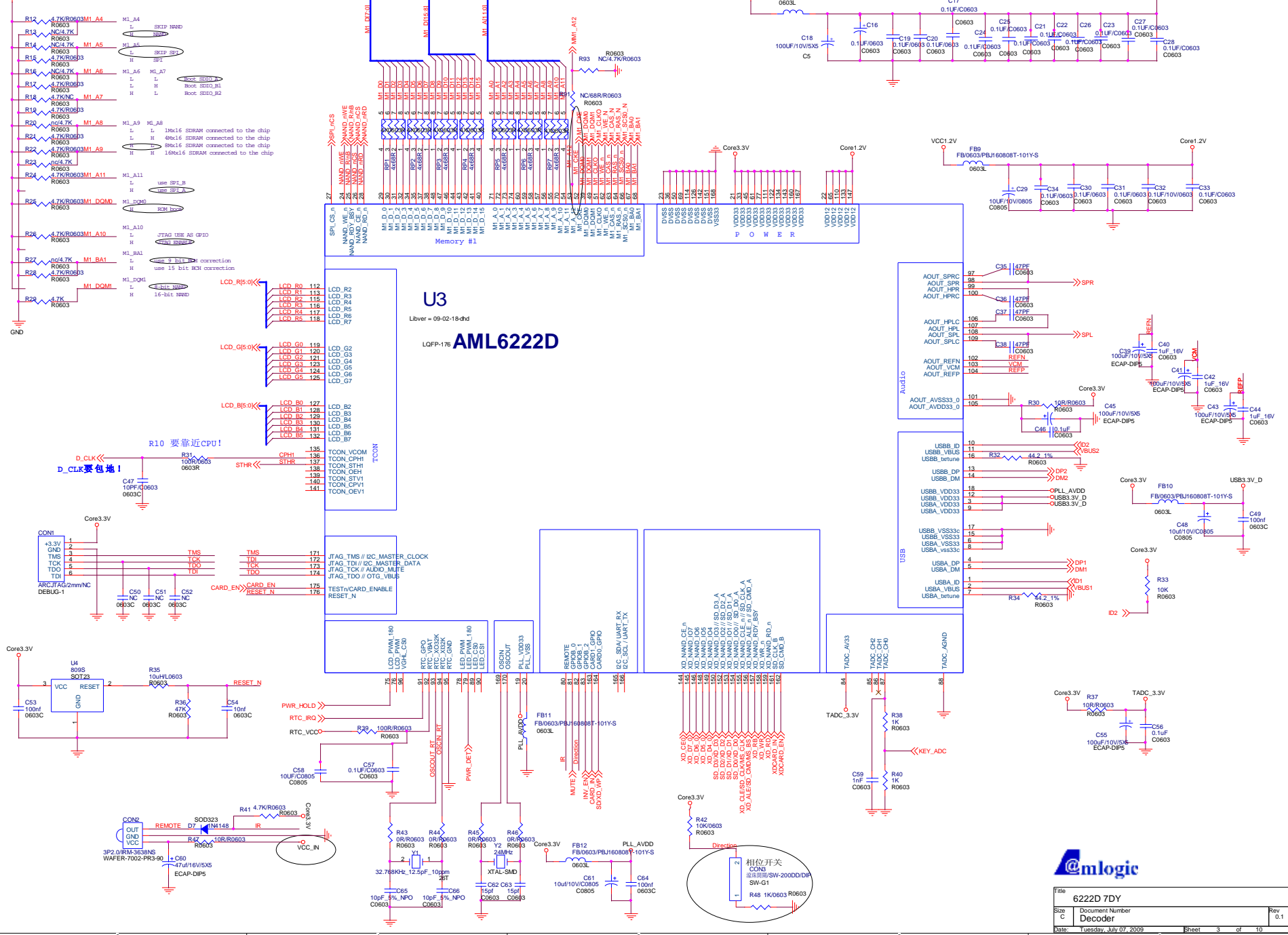

File	6222D 7DY		
Size	Document Number		Rev
C	Decoder		0.1
Date	Tuesday, July 07, 2009	Sheet	3 of 10

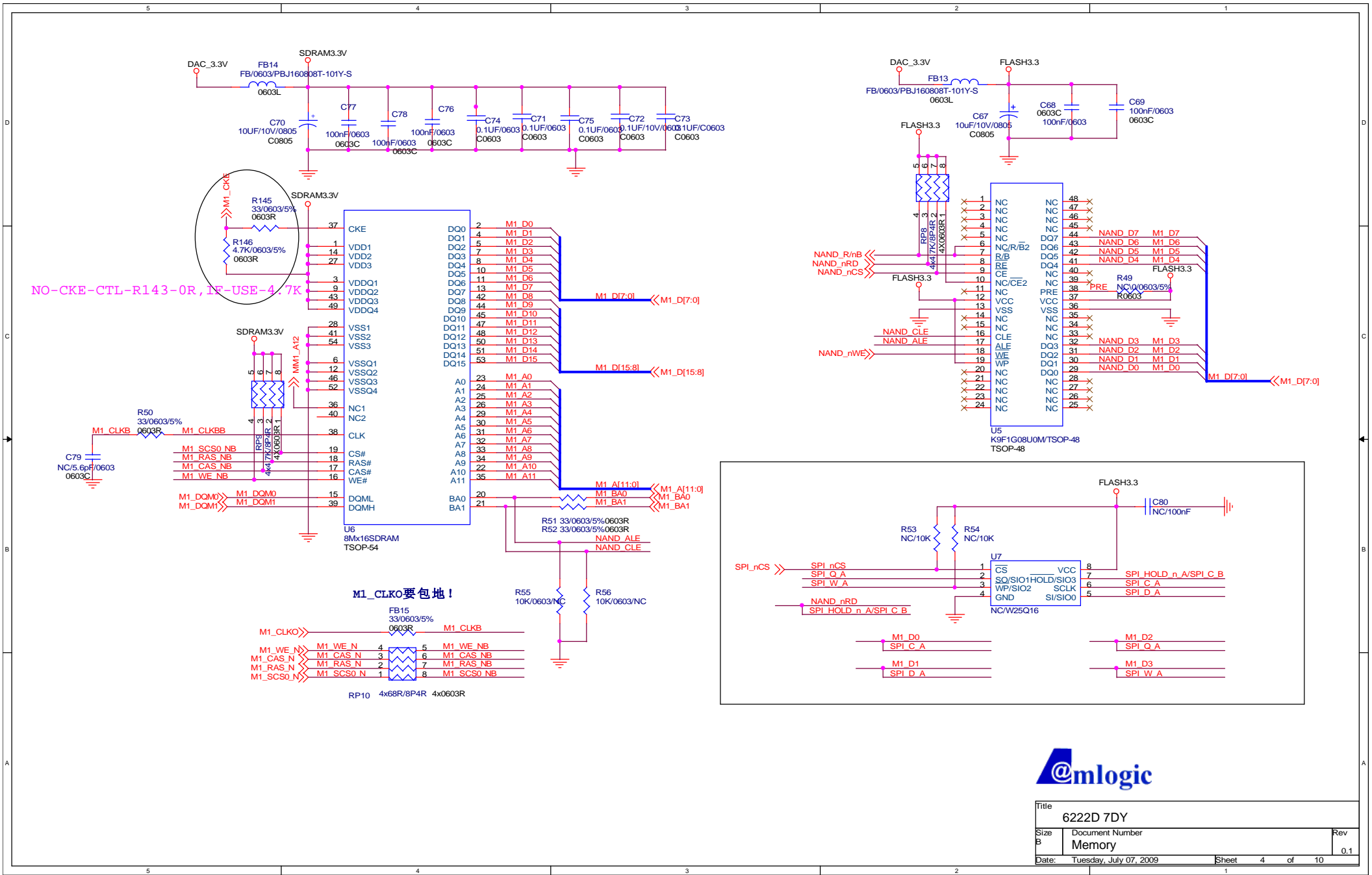

Title		6222D 7DY	
Size	Document Number	Rev	
B	Memory	0.1	
Date:	Tuesday, July 07, 2009	Sheet	4 of 10

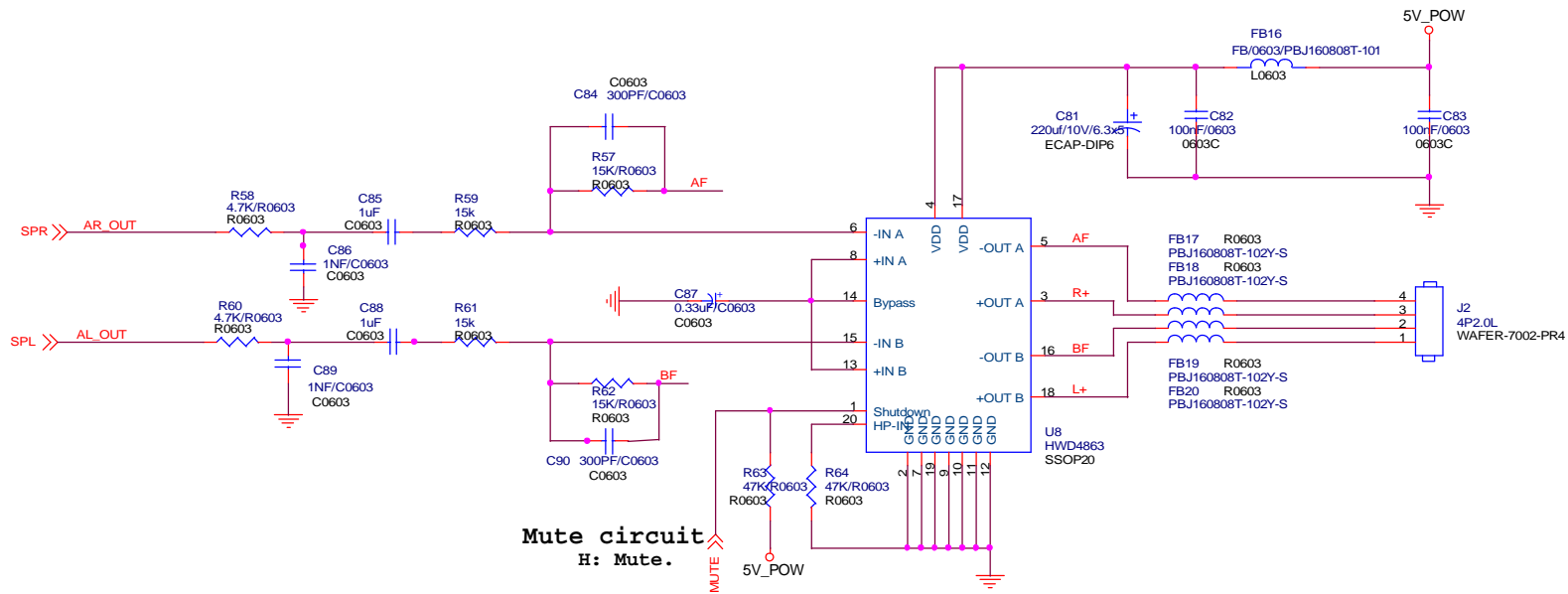

Title 6222D 7DY		
Size B	Document Number Audio	Rev 0.1
Date: Tuesday, July 07, 2009	Sheet 5 of 10	

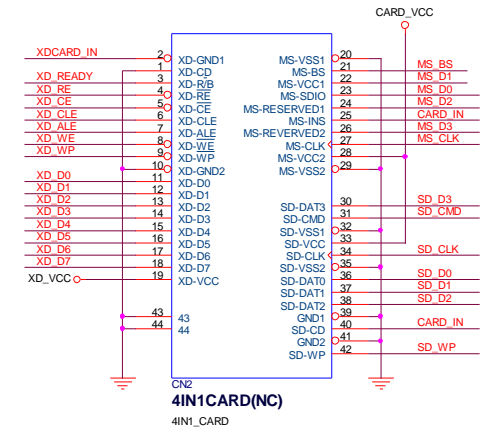
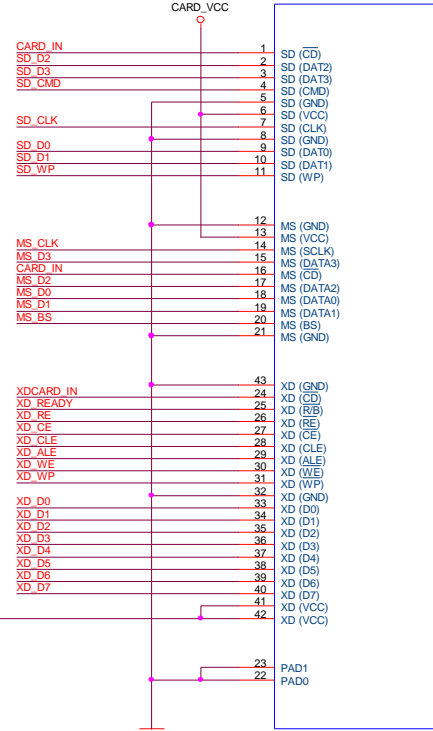
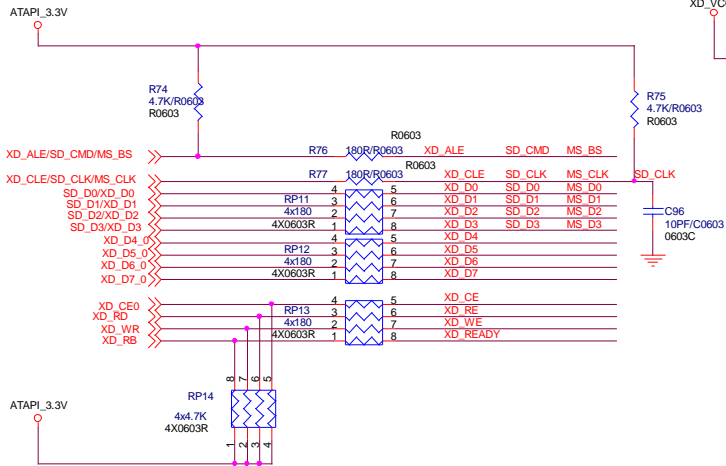
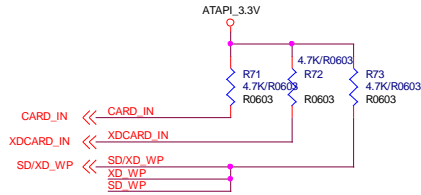
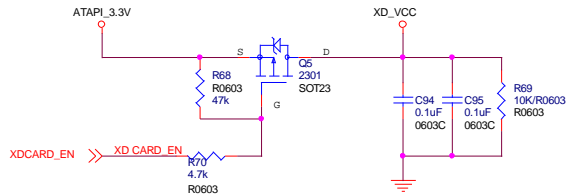
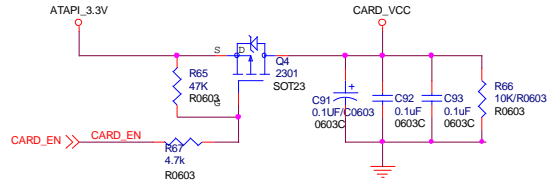

Title			6222D 7DY		
Size	Document Number	Rev			
Custom	Card	A.1			
Date:	Tuesday, July 07, 2009	Sheet	6	of	10

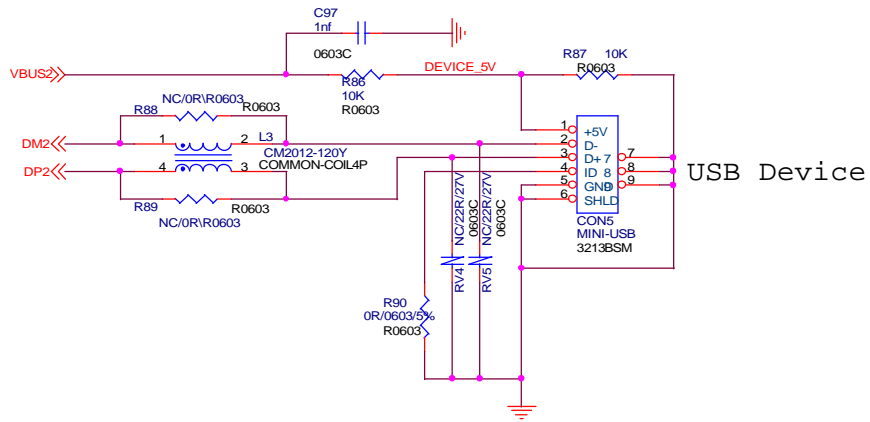
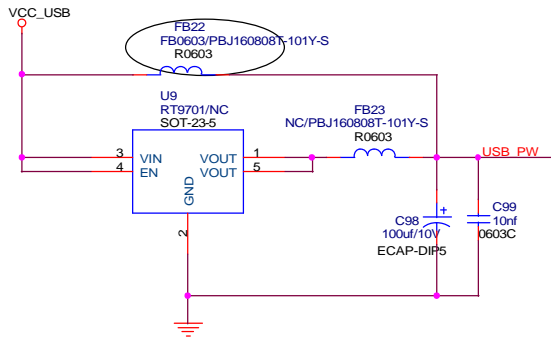
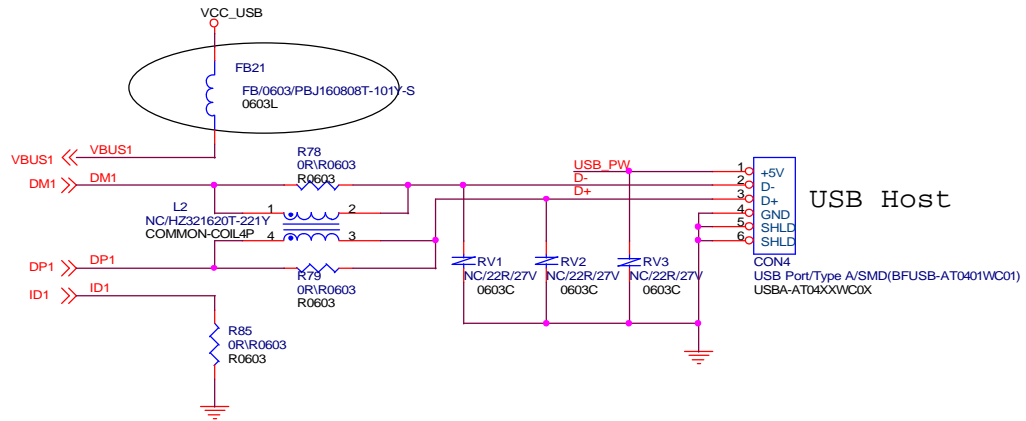
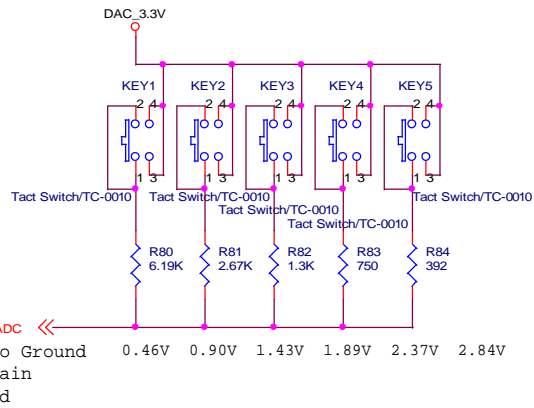

Title		
6222D 7DY		
Size B	Document Number	Rev 0.1
Date: Tuesday, July 07, 2009		Sheet 7 of 10



