

FCC TEST REPORT

For

7 inch Digital Photo Frame

MODEL No.: DF07204-14-XXX(X=A-Z, a-z, 0-9)

Trademark: N/A

FCC ID: V37-6222-7DN

REPORT NO: KA09066046E

ISSUE DATE: July 13, 2009

Prepared for

WIN ACCORD LTD.

**12F, 225, Sec 5, 105 Song Shan Dist.,
Nan Jing East Road, Taipei, Taiwan**

Prepared by

DONGGUAN EMTEK CO., LTD

**No. 281, Guantai Road, Nancheng District,
Dongguan, Guangdong, China**

TEL: +86-769-22807078

FAX: +86-769-22807079

TABLE OF CONTENTS

1. GENERAL INFORMATION	4
1.1. Description of Device (EUT).....	4
1.2. Description of Support Device	6
1.3 Test Facility	7
1.4 Measurement Uncertainty.....	7
2. POWER LINE CONDUCTED MEASUREMENT.....	8
2.1. Test Equipment.....	8
2.2. Block Diagram of Test Setup.....	8
2.3. Power Line Conducted Emission Measurement Limits.....	9
2.4. Configuration of EUT on Measurement	9
2.5. Operating Condition of EUT	9
2.6. Test Procedure	9
2.7. Power Line Conducted Emission Measurement Results	10
3. RADIATED EMISSION MEASUREMENT	38
3.1. Test Equipment.....	38
3.2. Block Diagram of Test Setup.....	39
3.3. Radiated Emission Limit	39
3.4. EUT Configuration on Measurement	40
3.5. Operating Condition of EUT	40
3.6. Test Procedure	40
3.7. Radiated Emission Noise Measurement Results.....	40

TEST REPORT DESCRIPTION

Applicant : WIN ACCORD LTD.
Manufacturer : WIN ACCORD LTD.
EUT : 7 inch Digital Photo Frame
FCC ID No. : V37-6222-7DN
Test Voltage : 120V/60Hz
File Number : KA09066046E
Date of Test : July 09, 2009 to July 13, 2009

Measurement Procedure Used:

FCC Rules and Regulations Part 15 Subpart B Class B July 2008 & FCC / ANSI C63.4-2003

The device described above is tested by Dongguan EMTEK Co., Ltd. to determine the maximum emission levels emanating from the device. The maximum emission levels are compared to the FCC Part 15 Subpart Class B limits both radiated and conducted emissions. The measurement results are contained in this test report and Dongguan EMTEK Co., Ltd. is assumed full responsibility for the accuracy and completeness of these measurements. Also, this report shows that the Equipment Under Test (EUT) is to be technically compliant with the FCC requirements.

This report applies to above tested sample only. This report shall not be reproduced in part without written approval of Dongguan EMTEK Co., Ltd.

Approved By



Nicol Lee / Q.A. Manager
DONGGUAN EMTEK CO., LTD.

1. GENERAL INFORMATION

1.1. Description of Device (EUT)

EUT : 7 inch Digital Photo Frame

Model Number : Basic Model: DF07204-14-XXX, (X=A-Z, a-z, 0-9)
Additional Model: BS07N.

(Note: Those models are the same except appearance and model names, all models use the same FCC ID Number.)

Cable : USB Line, 1.5m shielded line, with a core.

FCC ID Number : V37-6222-7DN

Trade Mark : N/A

Power Supply : 100~240V 50/60Hz

ADAPTER 1 : Manufacturer: HONOR ELECTRONIC CO., LTD.
M/N: ADS-12G-0605010GPCU
Input: AC 100~240V 50/60Hz
Output: DC 5V 2.0A
Output line: Unshielded line (with a core)

ADAPTER 2 : Manufacturer: E-TEK Electronics Manufactory Ltd.
M/N: ZDA050200US
Input: AC 100~240V 50/60Hz
Output: DC 5V 2.0A
Output line: Unshielded line (with a core)

ADAPTER 3 : Manufacturer: MOSO
M/N: XKD-C2000IC5.0-12W
Input: AC 100~240V 50/60Hz
Output: DC 5V 2.0A
Output line: Unshielded line (with a core)

Remark : They are different model name and appearance.

Applicant : WIN ACCORD LTD.

Address : 12F, 225, Sec 5, 105 Song Shan Dist., Nan Jing East Road,
Taipei, Taiwan

Manufacturer : WIN ACCORD LTD.

Address : 12F, 225, Sec 5, 105 Song Shan Dist., Nan Jing East Road,
Taipei, Taiwan

Date of sample : July 09, 2009
i

Date of Test : July 09, 2009 to July 13, 2009

1.2. Description of Support Device

PC	: Manufacturer: Dell Inc. M/N: DCSM S/N: CXBMMZX FCC ID: DoC
LCD Monitor	: Manufacturer: Dell Inc. M/N: E1909Wf FCC ID: DoC
USB Mouse	: Manufacturer: Dell Inc. M/N: M-UAK DEL7 P/N: XN966 FCC ID: DoC
USB Keyboard	: Manufacturer: Dell Inc. M/N: L30U S/N:D1C FCC ID: DoC
Printer	: Manufacturer: HP M/N:HP LaserJet 1020 S/N: CNCK512065 P/N: Q5911A FCC ID: DoC
USB	: Kingston 2GB
SD Card	: Kingston 2GB

1.3 Test Facility

Site Description

EMC Lab. : Accredited by CNAS, 2007.07.27
The certificate is valid until 2012.07.26
The Laboratory has been assessed and proved to be in compliance with CNAS/CL01:2005
The Certificate Registration Number is L3150

Accredited by TUV Rheinland Shenzhen 2008.5
The certificate is valid until 2009.12
The Laboratory has been assessed according to the requirements ISO/IEC 17025

Accredited by FCC, Nov. 05, 2008
The Certificate Number is 247565.

Accredited by Industry Canada, May 24, 2008
The Certificate Registration Number. is 46405-4480

Name of Firm : Dongguan EMTEK Co., Ltd.
Site Location : No.281, Guantai Road, Nancheng District, Dongguan, Guangdong, China.

1.4 Measurement Uncertainty

Conducted Emission Uncertainty : $U_r = 3.3$

Radiated Emission Uncertainty : $U_c = 2.8$

Disturbance Power Uncertainty : $U_c = 2.6$

2. POWER LINE CONDUCTED MEASUREMENT

2.1. Test Equipment

The following test equipments are used during the power line conducted measurement:

Item	Equipment	Manufacturer	Model No.	Serial No.	Last Cal.	Cal. Interval
1	EMI Test Receiver	ROHDE&SCHWARZ	ESCS30	828985/018	May 29, 2009	1 Year
2	LISN	ROHDE&SCHWARZ	ENV216	100017	May 29, 2009	1Year
3	Conical Housing	EMTEK	N/A	N/A	May 29, 2009	N/A
4	Voltage Probe	SCHWARZBECK	EZ-17	100213	May 29, 2008	1Year
5	50 Ω Coaxial Switch	ANRITSU CORP	MP59B	6100175589	May 29, 2009	1Year

2.2. Block Diagram of Test Setup

2.2.1 Block diagram of connection between the EUT and simulators

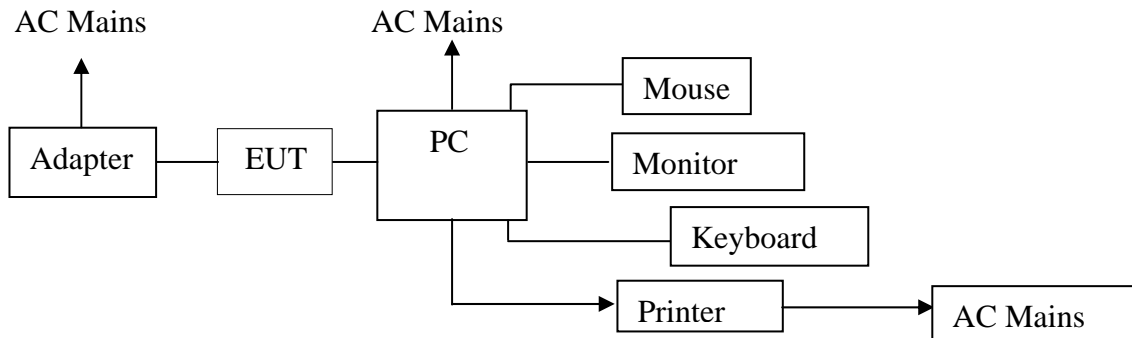

(EUT: 7 inch Digital Photo Frame)

2.2.2 Block diagram of test setup

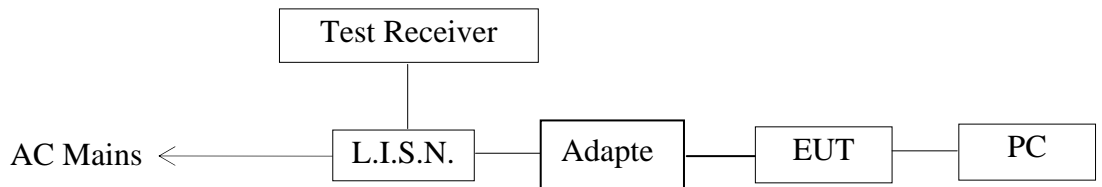

(EUT: 7 inch Digital Photo Frame)

2.3. Power Line Conducted Emission Measurement Limits

Conducted Emission Limits is as following.

Frequency MHz	Limits dB(μ V)	
	Quasi-peak Level	Average Level
0.15 ~ 0.50	66 ~ 56*	56 ~ 46*
0.50 ~ 5.00	56	46
5.00 ~ 30.00	60	50

- Notes: 1. *Decreasing linearly with logarithm of frequency.
2. The lower limit shall apply at the transition frequencies.

2.4. Configuration of EUT on Measurement

The following equipments are installed on Power Line Conducted Emission Measurement to meet the commission requirement and operating regulations in a manner which tends to maximize its emission characteristics in a normal application.

EUT : 7 inch Digital Photo Frame
Model Number : BS07N
Manufacturer : WIN ACCORD LTD.

2.5. Operating Condition of EUT

2.5.1. Setup the EUT and simulator as shown as Section 2.2.

2.5.2. Turn on the power of all equipment.

2.5.3. Let the EUT work in test model (Memorying, SD Card Playing, USB Playing, Connect to PC) and measure it.

2.6. Test Procedure

The EUT system is connected to the power mains through a line impedance stabilization network (L.I.S.N.). This provides a 50ohm coupling impedance for the EUT system. Please refer the block diagram of the test setup and photographs. Both sides of AC line are checked to find out the maximum conducted emission. In order to find the maximum emission levels, the relative positions of equipment and all of the interface cables shall be changed according to FCC ANSI C63.4-2003 on Conducted Emission Measurement.

The bandwidth of test receiver (R&S ESCS30) is set at 9KHz.
The frequency range from 150KHz to 30MHz is checked.

2.7. Power Line Conducted Emission Measurement Results

PASS

The frequency range from 150KHz to 30 MHz is investigated.

The scanning waveforms refer to the following pages.

Adapter ADS-12G-0605010GPCU used for test.

Conducted Emission Measurement

File :BS07N(CMO)
 80.0 dBuV

Data :#19

Date: 2009-7-9

Time: 15:22:00

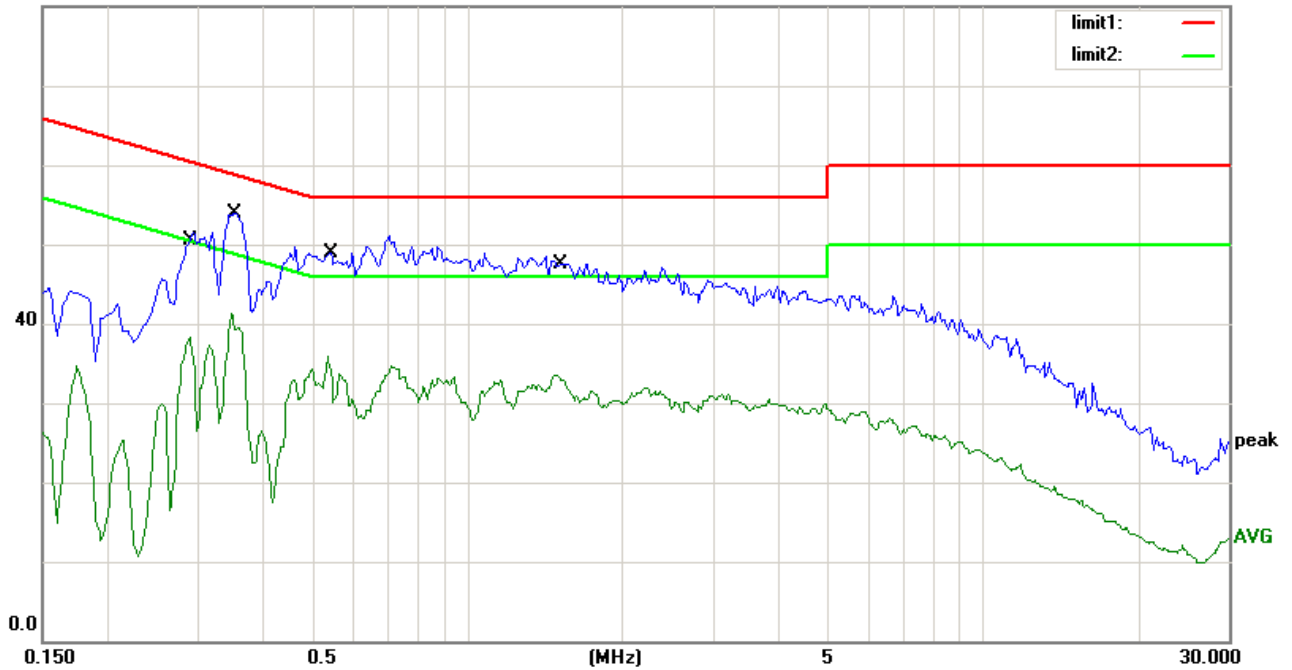

Site site #1

Phase: **L1**

Temperature: 25

Limit: (CE)FCC PART 15 class B_QP

Power: AC 120V/60Hz

Humidity: 50 %

EUT: 7 INCH DIGITAL PHOTO FRAME

M/N: BS07N

Mode: USB PLAYING

Note: ADS-12G-0605010GPCU

No.	Mk.	Freq. MHz	Reading Level dBuV	Correct Factor dB	Measure- ment dBuV	Limit dBuV	Over dB	Detector	Comment
1		0.2863	47.20	0.00	47.20	60.63	-13.43	QP	
2		0.2863	37.57	0.00	37.57	50.63	-13.06	AVG	
3		0.3500	51.20	0.00	51.20	58.96	-7.76	QP	
4	*	0.3500	41.23	0.00	41.23	48.96	-7.73	AVG	
5		0.5407	45.20	0.00	45.20	56.00	-10.80	QP	
6		0.5407	34.81	0.00	34.81	46.00	-11.19	AVG	
7		1.5250	43.60	0.00	43.60	56.00	-12.40	QP	
8		1.5250	32.96	0.00	32.96	46.00	-13.04	AVG	

*:Maximum data x:Over limit !:over margin Comment: Factor build in receiver. Operator:

Conducted Emission Measurement

File :BS07N(CMO)
 80.0 dBuV

Data :#20

Date: 2009-7-9

Time: 15:28:00

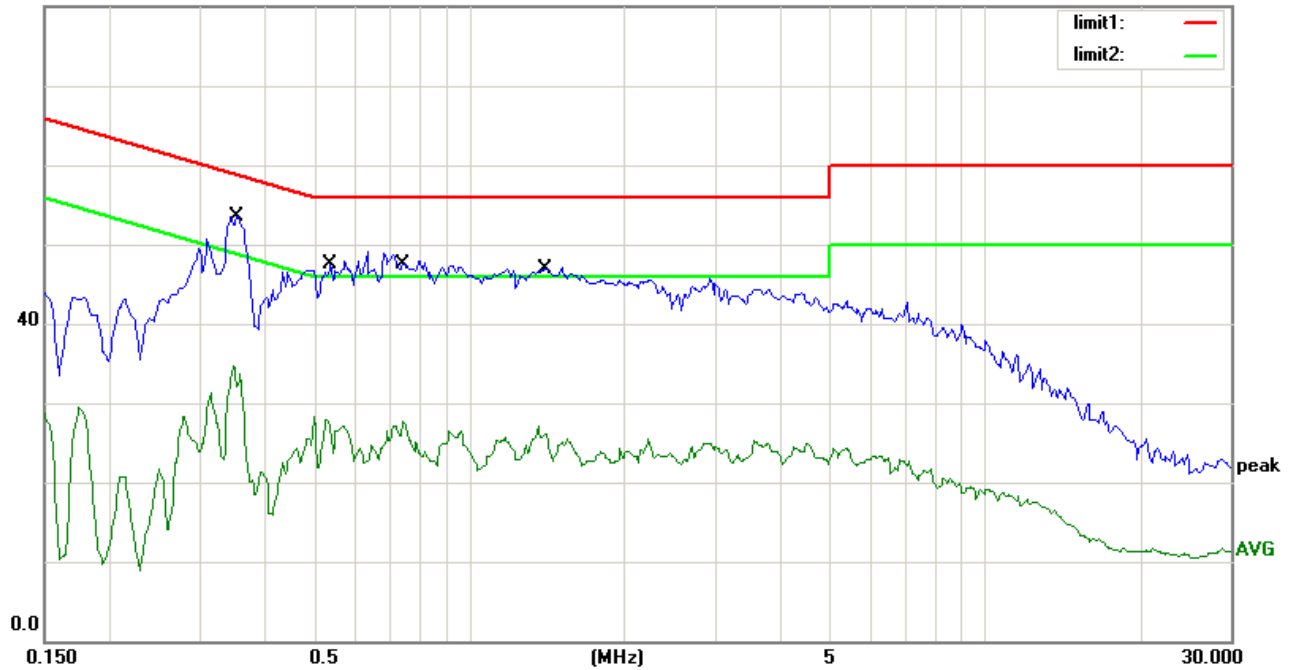

Site site #1

Phase: **N**

Temperature: 25

Limit: (CE)FCC PART 15 class B_QP

Power: AC 120V/60Hz

Humidity: 50 %

EUT: 7 INCH DIGITAL PHOTO FRAME

M/N: BS07N

Mode: USB PLAYING

Note: ADS-12G-0605010GPCU

No.	Mk.	Freq. MHz	Reading Level dBuV	Correct Factor dB	Measure- ment dBuV	Limit dBuV	Over dB	Detector	Comment
1	*	0.3550	50.30	0.00	50.30	58.84	-8.54	QP	
2		0.3550	32.14	0.00	32.14	48.84	-16.70	AVG	
3		0.5300	43.60	0.00	43.60	56.00	-12.40	QP	
4		0.5300	27.99	0.00	27.99	46.00	-18.01	AVG	
5		0.7450	43.50	0.00	43.50	56.00	-12.50	QP	
6		0.7450	27.69	0.00	27.69	46.00	-18.31	AVG	
7		1.3958	41.60	0.00	41.60	56.00	-14.40	QP	
8		1.3958	25.90	0.00	25.90	46.00	-20.10	AVG	

*:Maximum data x:Over limit !:over margin Comment: Factor build in receiver. Operator:

Conducted Emission Measurement

File :BS07N(CMO)
 80.0 dBuV

Data :#21

Date: 2009-7-9

Time: 15:33:34

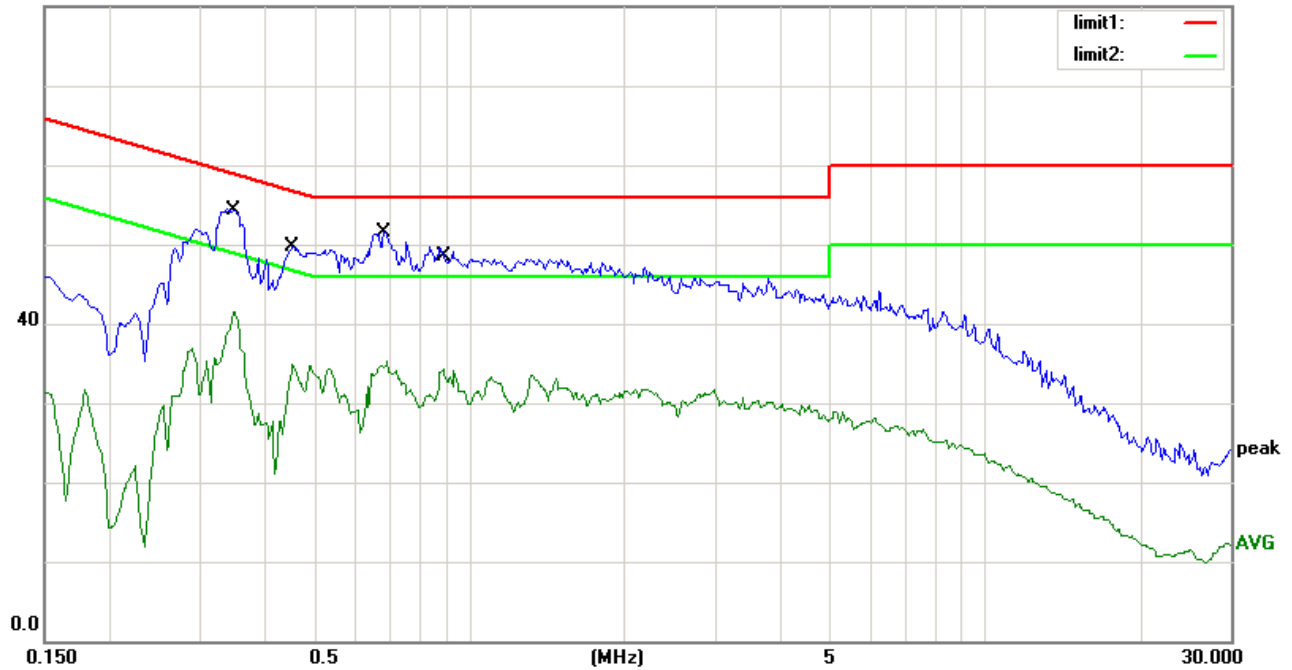

Site site #1

Phase: **L1**

Temperature: 25

Limit: (CE)FCC PART 15 class B_QP

Power: AC 120V/60Hz

Humidity: 50 %

EUT: 7 INCH DIGITAL PHOTO FRAME

M/N: BS07N

Mode: SD CARD PLAYING

Note: ADS-12G-0605010GPCU

No.	Mk.	Freq. MHz	Reading Level dBuV	Correct Factor dB	Measure- ment dBuV	Limit dBuV	Over dB	Detector	Comment
1	*	0.3520	51.70	0.00	51.70	58.92	-7.22	QP	
2		0.3520	41.27	0.00	41.27	48.92	-7.65	AVG	
3		0.4564	46.40	0.00	46.40	56.76	-10.36	QP	
4		0.4564	34.70	0.00	34.70	46.76	-12.06	AVG	
5		0.6750	45.20	0.00	45.20	56.00	-10.80	QP	
6		0.6750	34.80	0.00	34.80	46.00	-11.20	AVG	
7		0.8992	43.90	0.00	43.90	56.00	-12.10	QP	
8		0.8992	33.25	0.00	33.25	46.00	-12.75	AVG	

*:Maximum data x:Over limit !:over margin Comment: Factor build in receiver. Operator:

Conducted Emission Measurement

File :BS07N(CMO)
 80.0 dBuV

Data :#22

Date: 2009-7-9

Time: 15:41:13

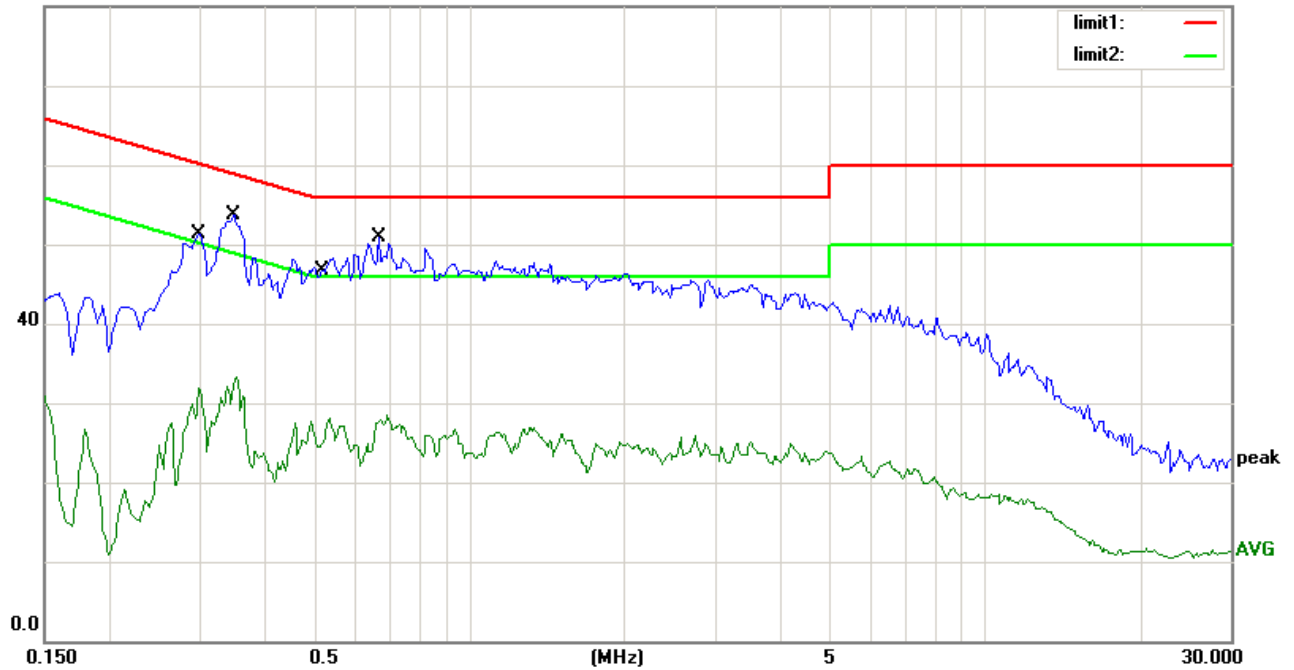

Site site #1

Phase: **N**

Temperature: 25

Limit: (CE)FCC PART 15 class B_QP

Power: AC 120V/60Hz

Humidity: 50 %

EUT: 7 INCH DIGITAL PHOTO FRAME

M/N: BS07N

Mode: SD CARD PLAYING

Note: ADS-12G-0605010GPCU

No.	Mk.	Freq. MHz	Reading Level dBuV	Correct Factor dB	Measure- ment dBuV	Limit dBuV	Over dB	Detector	Comment
1		0.2950	47.30	0.00	47.30	60.38	-13.08	QP	
2		0.2950	28.06	0.00	28.06	50.38	-22.32	AVG	
3	*	0.3520	50.40	0.00	50.40	58.92	-8.52	QP	
4		0.3520	32.89	0.00	32.89	48.92	-16.03	AVG	
5		0.5210	43.00	0.00	43.00	56.00	-13.00	QP	
6		0.5210	25.00	0.00	25.00	46.00	-21.00	AVG	
7		0.6750	43.60	0.00	43.60	56.00	-12.40	QP	
8		0.6750	27.81	0.00	27.81	46.00	-18.19	AVG	

*:Maximum data x:Over limit !:over margin Comment: Factor build in receiver. Operator:

Conducted Emission Measurement

File :BS07N(CMO)
 80.0 dBuV

Data :#23

Date: 2009-7-9

Time: 15:50:51

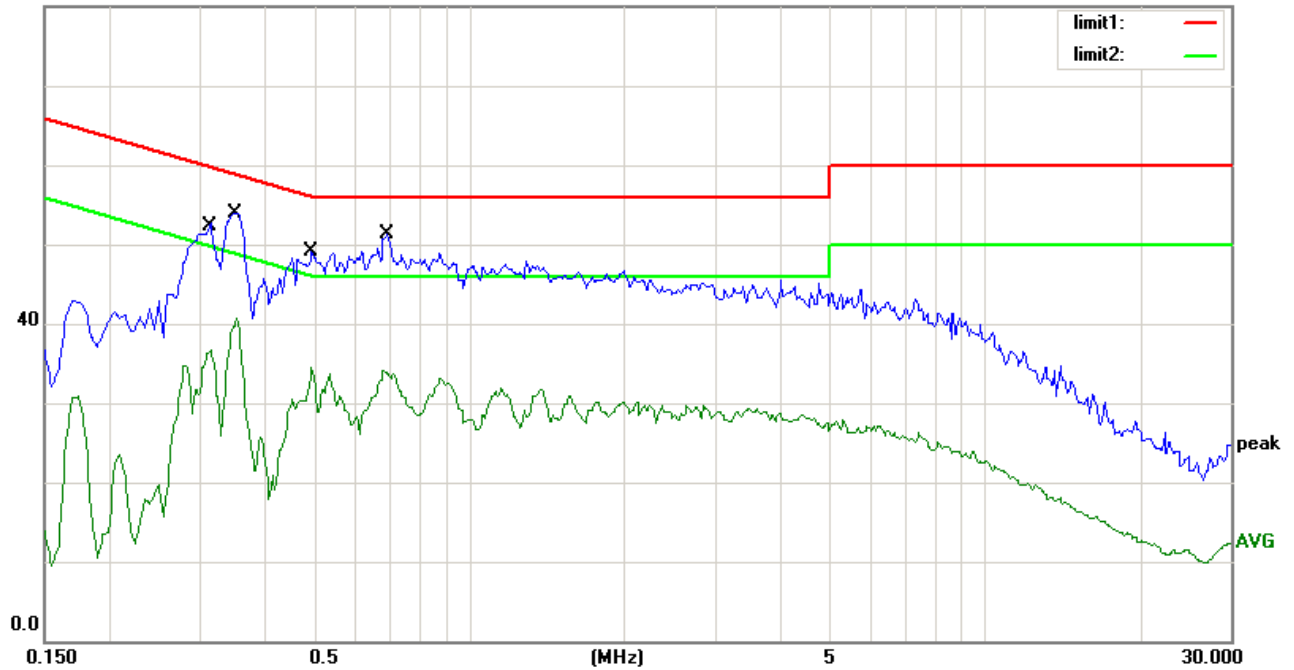

Site site #1

Phase: **N**

Temperature: 25

Limit: (CE)FCC PART 15 class B_QP

Power: AC 120V/60Hz

Humidity: 50 %

EUT: 7 INCH DIGITAL PHOTO FRAME

M/N: BS07N

Mode: Memorying

Note: ADS-12G-0605010GPCU

No.	Mk.	Freq. MHz	Reading Level dBuV	Correct Factor dB	Measure- ment dBuV	Limit dBuV	Over dB	Detector	Comment
1		0.3100	48.60	0.00	48.60	59.97	-11.37	QP	
2		0.3100	36.25	0.00	36.25	49.97	-13.72	AVG	
3	*	0.3550	51.10	0.00	51.10	58.84	-7.74	QP	
4		0.3550	40.78	0.00	40.78	48.84	-8.06	AVG	
5		0.4967	44.60	0.00	44.60	56.06	-11.46	QP	
6		0.4967	34.08	0.00	34.08	46.06	-11.98	AVG	
7		0.6950	43.40	0.00	43.40	56.00	-12.60	QP	
8		0.6950	33.77	0.00	33.77	46.00	-12.23	AVG	

*:Maximum data x:Over limit !:over margin Comment: Factor build in receiver. Operator:

Conducted Emission Measurement

File :BS07N(CMO)
 80.0 dBuV

Data :#24

Date: 2009-7-9

Time: 15:56:05

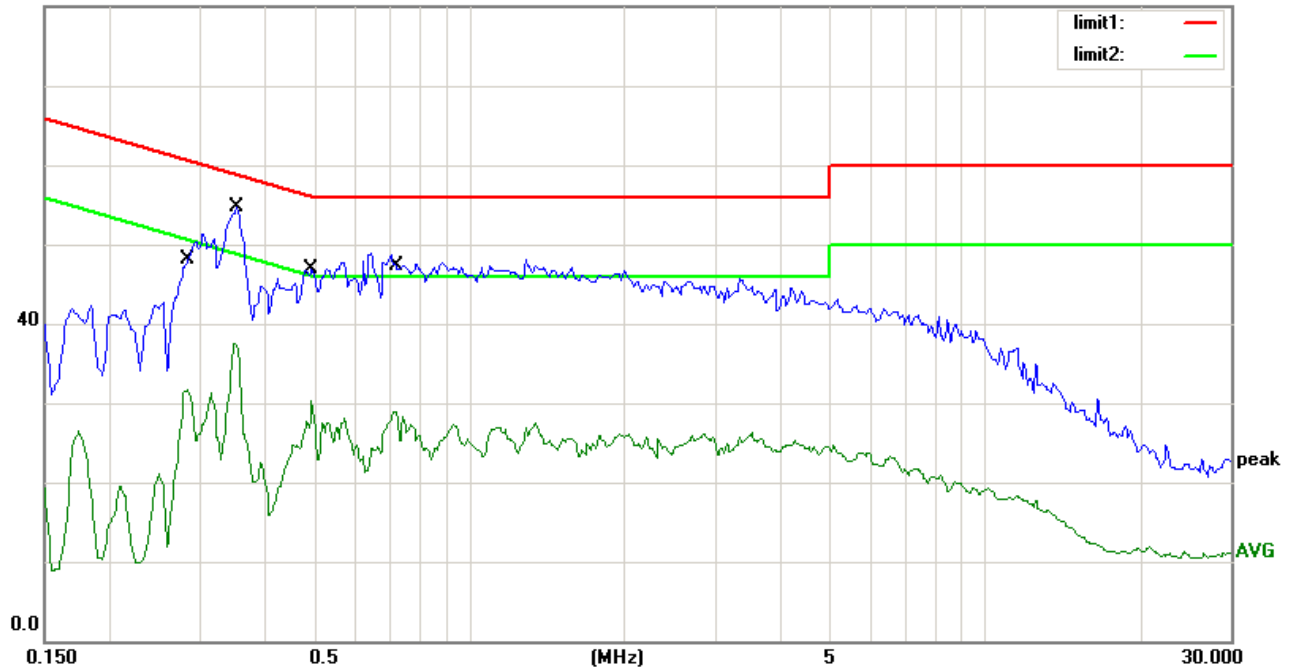

Site site #1

Phase: **L1**

Temperature: 25

Limit: (CE)FCC PART 15 class B_QP

Power: AC 120V/60Hz

Humidity: 50 %

EUT: 7 INCH DIGITAL PHOTO FRAME

M/N: BS07N

Mode: Memorying

Note: ADS-12G-0605010GPCU

No.	Mk.	Freq. MHz	Reading Level dBuV	Correct Factor dB	Measure- ment dBuV	Limit dBuV	Over dB	Detector	Comment
1		0.2818	45.00	0.00	45.00	60.76	-15.76	QP	
2		0.2818	31.53	0.00	31.53	50.76	-19.23	AVG	
3	*	0.3520	50.10	0.00	50.10	58.92	-8.82	QP	
4		0.3520	37.45	0.00	37.45	48.92	-11.47	AVG	
5		0.4950	43.70	0.00	43.70	56.08	-12.38	QP	
6		0.4950	30.30	0.00	30.30	46.08	-15.78	AVG	
7		0.7250	43.50	0.00	43.50	56.00	-12.50	QP	
8		0.7250	28.95	0.00	28.95	46.00	-17.05	AVG	

*:Maximum data x:Over limit !:over margin Comment: Factor build in receiver. Operator:

Conducted Emission Measurement

File :BS07N(CMO)
 80.0 dBuV

Data :#38

Date: 2009-7-9

Time: 17:58:19

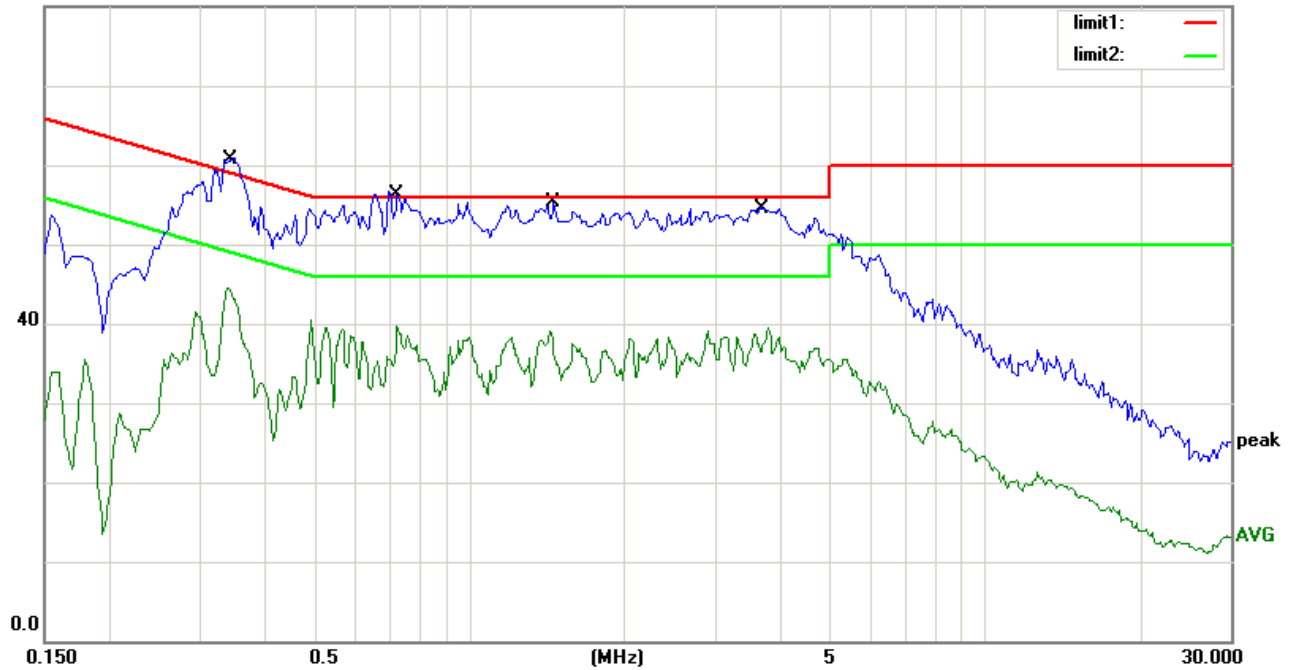

Site site #1

Phase: **L1**

Temperature: 25

Limit: (CE)FCC PART 15 class B_QP

Power: AC 120V/60Hz

Humidity: 50 %

EUT: 7 INCH DIGITAL PHOTO FRAME

M/N: BS07N

Mode: CONNECT TO PC

Note: ADS-12G-0605010GPCU

No.	Mk.	Freq. MHz	Reading Level dBuV	Correct Factor dB	Measure- ment dBuV	Limit dBuV	Over dB	Detector	Comment
1		0.3400	52.60	0.00	52.60	59.20	-6.60	QP	
2		0.3400	38.30	0.00	38.30	49.20	-10.90	AVG	
3	*	0.7273	51.00	0.00	51.00	56.00	-5.00	QP	
4		0.7273	37.50	0.00	37.50	46.00	-8.50	AVG	
5		1.4410	49.70	0.00	49.70	56.00	-6.30	QP	
6		1.4410	37.00	0.00	37.00	46.00	-9.00	AVG	
7		3.7395	49.50	0.00	49.50	56.00	-6.50	QP	
8		3.7395	36.50	0.00	36.50	46.00	-9.50	AVG	

*:Maximum data x:Over limit !:over margin Comment: Factor build in receiver. Operator:

Conducted Emission Measurement

File :BS07N(CMO)
 80.0 dBuV

Data :#39

Date: 2009-7-9

Time: 18:04:01

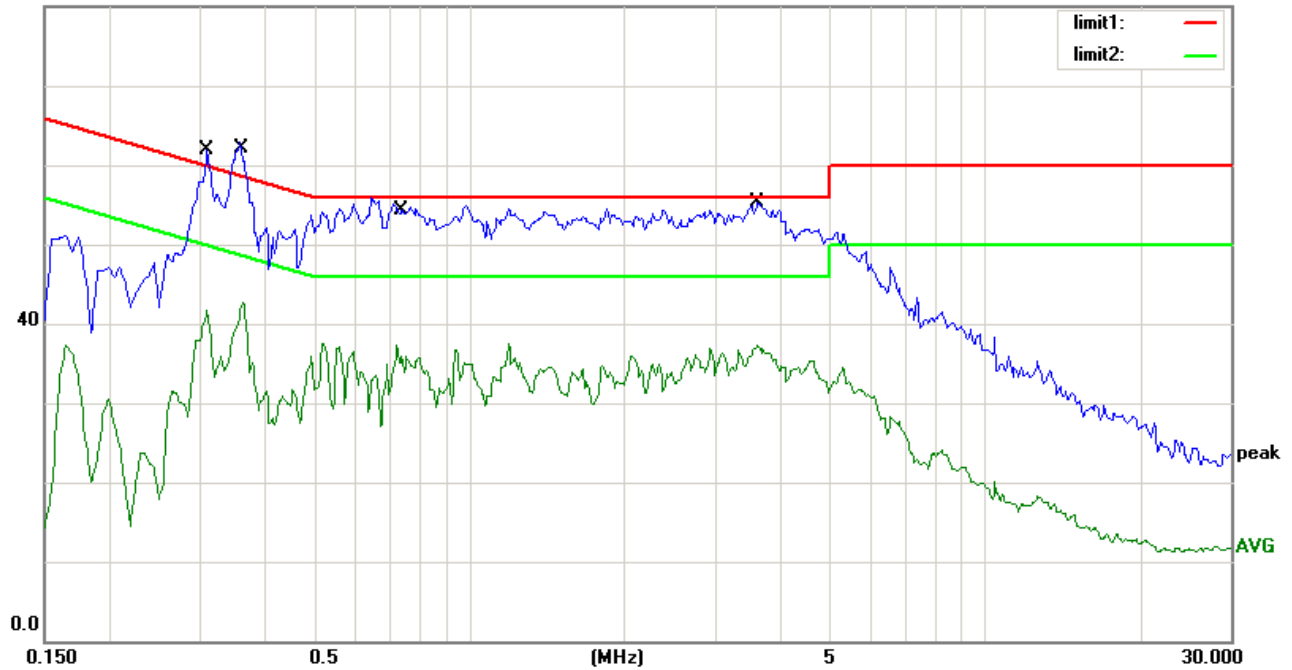

Site site #1

Phase: **N**

Temperature: 25

Limit: (CE)FCC PART 15 class B_QP

Power: AC 120V/60Hz

Humidity: 50 %

EUT: 7 INCH DIGITAL PHOTO FRAME

M/N: BS07N

Mode: CONNECT TO PC

Note: ADS-12G-0605010GPCU

No.	Mk.	Freq. MHz	Reading Level dBuV	Correct Factor dB	Measure- ment dBuV	Limit dBuV	Over dB	Detector	Comment
1		0.3100	56.10	0.00	56.10	59.97	-3.87	QP	
2		0.3100	41.73	0.00	41.73	49.97	-8.24	AVG	
3	*	0.3650	55.80	0.00	55.80	58.61	-2.81	QP	
4		0.3650	42.64	0.00	42.64	48.61	-5.97	AVG	
5		0.7350	50.30	0.00	50.30	56.00	-5.70	QP	
6		0.7350	35.10	0.00	35.10	46.00	-10.90	AVG	
7		3.6300	49.20	0.00	49.20	56.00	-6.80	QP	
8		3.6300	37.29	0.00	37.29	46.00	-8.71	AVG	

*:Maximum data x:Over limit !:over margin Comment: Factor build in receiver. Operator:

Adapter ZDA050200US used for test.

Conducted Emission Measurement

File :BS07N(CMO)
 80.0 dBuV

Data :#25

Date: 2009-7-9

Time: 16:02:54

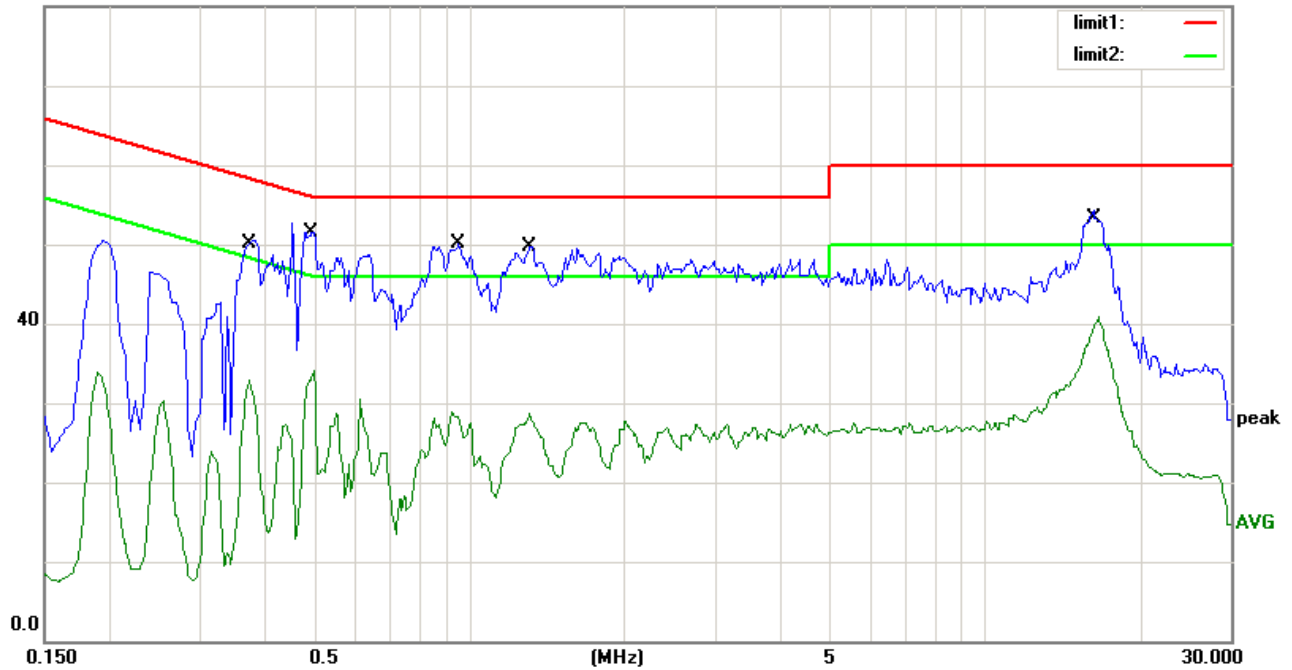

Site site #1

Phase: **L1**

Temperature: 25

Limit: (CE)FCC PART 15 class B_QP

Power: AC 120V/60Hz

Humidity: 50 %

EUT: 7 INCH DIGITAL PHOTO FRAME

M/N: BS07N

Mode: Memorying

Note: ZDA050200US

No.	Mk.	Freq. MHz	Reading Level dBuV	Correct Factor dB	Measure- ment dBuV	Limit dBuV	Over dB	Detector	Comment
1		0.3712	46.90	0.00	46.90	58.47	-11.57	QP	
2		0.3712	31.85	0.00	31.85	48.47	-16.62	AVG	
3	*	0.4967	48.20	0.00	48.20	56.06	-7.86	QP	
4		0.4967	33.40	0.00	33.40	46.06	-12.66	AVG	
5		0.9400	44.70	0.00	44.70	56.00	-11.30	QP	
6		0.9400	28.32	0.00	28.32	46.00	-17.68	AVG	
7		1.2960	43.50	0.00	43.50	56.00	-12.50	QP	
8		1.2960	27.89	0.00	27.89	46.00	-18.11	AVG	
9		16.4856	47.80	0.00	47.80	60.00	-12.20	QP	
10		16.4856	40.38	0.00	40.38	50.00	-9.62	AVG	

*:Maximum data x:Over limit !:over margin Comment: Factor build in receiver. Operator:

Conducted Emission Measurement

File :BS07N(CMO)
 80.0 dBuV

Data :#26

Date: 2009-7-9

Time: 16:09:02

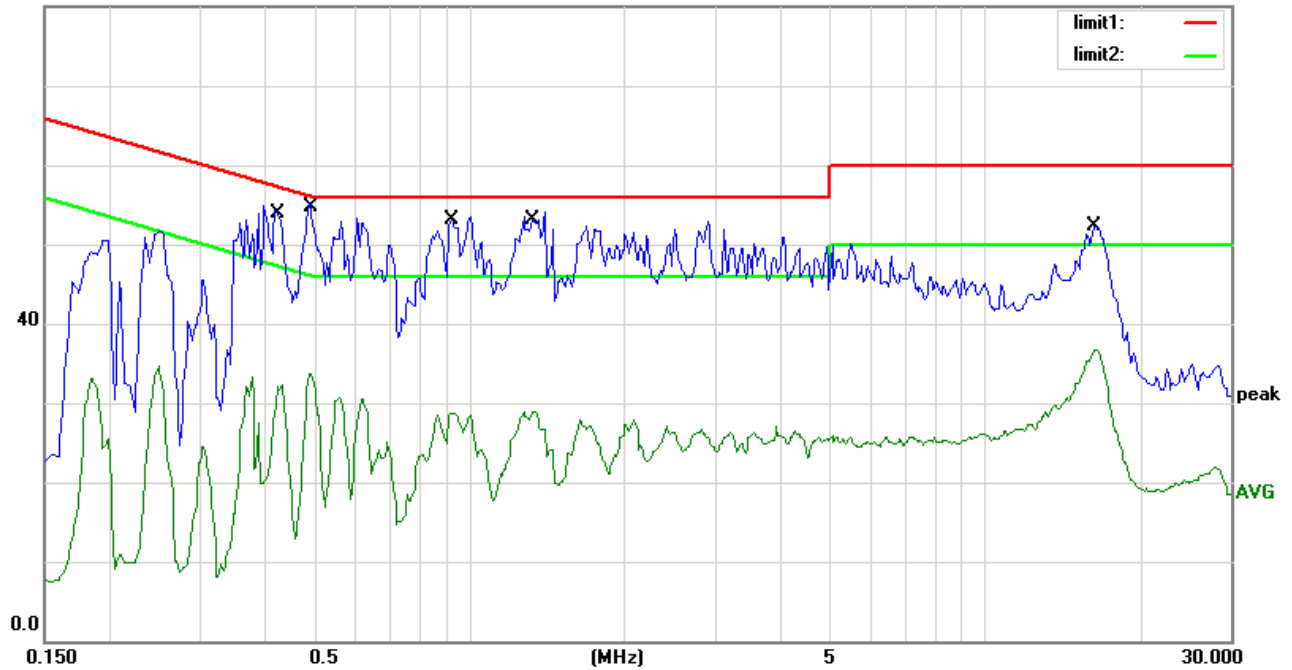

Site site #1

Phase: **N**

Temperature: 25

Limit: (CE)FCC PART 15 class B_QP

Power: AC 120V/60Hz

Humidity: 50 %

EUT: 7 INCH DIGITAL PHOTO FRAME

M/N: BS07N

Mode: Memorying

Note: ZDA050200US

No.	Mk.	Freq. MHz	Reading Level dBuV	Correct Factor dB	Measure- ment dBuV	Limit dBuV	Over dB	Detector	Comment
1		0.4300	46.00	0.00	46.00	57.25	-11.25	QP	
2		0.4300	31.79	0.00	31.79	47.25	-15.46	AVG	
3	*	0.4950	47.70	0.00	47.70	56.08	-8.38	QP	
4		0.4950	33.63	0.00	33.63	46.08	-12.45	AVG	
5		0.9184	43.90	0.00	43.90	56.00	-12.10	QP	
6		0.9184	28.61	0.00	28.61	46.00	-17.39	AVG	
7		1.3100	43.40	0.00	43.40	56.00	-12.60	QP	
8		1.3100	28.00	0.00	28.00	46.00	-18.00	AVG	
9		16.4250	45.50	0.00	45.50	60.00	-14.50	QP	
10		16.4250	36.63	0.00	36.63	50.00	-13.37	AVG	

*:Maximum data x:Over limit !:over margin Comment: Factor build in receiver. Operator:

Conducted Emission Measurement

File :BS07N(CMO)
 80.0 dBuV

Data :#42

Date: 2009-7-9

Time: 18:16:50

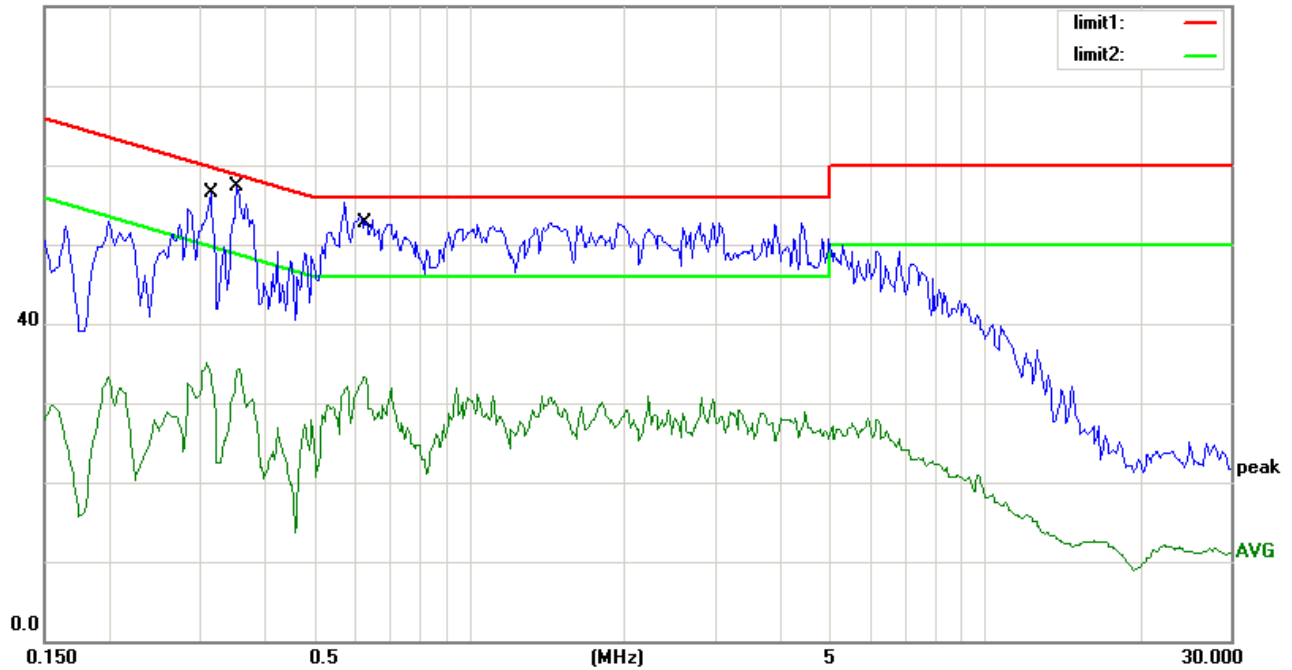

Site site #1

Phase: **L1**

Temperature: 25

Limit: (CE)FCC PART 15 class B_QP

Power: AC 120V/60Hz

Humidity: 50 %

EUT: 7 INCH DIGITAL PHOTO FRAME

M/N: BS07N

Mode: USB PLAYING

Note: ZDA050200US

No.	Mk.	Freq. MHz	Reading Level dBuV	Correct Factor dB	Measure- ment dBuV	Limit dBuV	Over dB	Detector	Comment
1		0.3133	48.90	0.00	48.90	59.88	-10.98	QP	
2		0.3133	34.70	0.00	34.70	49.88	-15.18	AVG	
3		0.3558	47.70	0.00	47.70	58.83	-11.13	QP	
4		0.3558	33.50	0.00	33.50	48.83	-15.33	AVG	
5	*	0.6300	49.00	0.00	49.00	56.00	-7.00	QP	
6		0.6300	33.00	0.00	33.00	46.00	-13.00	AVG	

*:Maximum data x:Over limit !:over margin Comment: Factor build in receiver. Operator:

Conducted Emission Measurement

File :BS07N(CMO)
 80.0 dBuV

Data :#27

Date: 2009-7-9

Time: 16:14:47

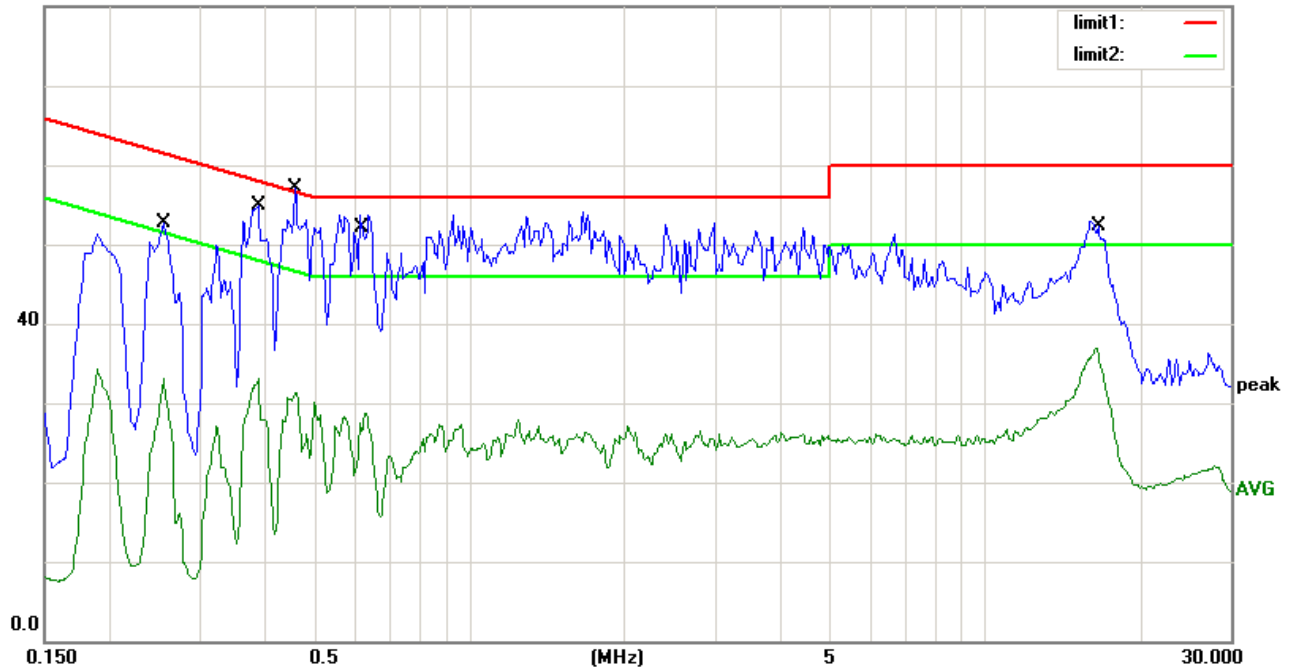

Site site #1

Phase: **N**

Temperature: 25

Limit: (CE)FCC PART 15 class B_QP

Power: AC 120V/60Hz

Humidity: 50 %

EUT: 7 INCH DIGITAL PHOTO FRAME

M/N: BS07N

Mode: USB PLAYING

Note: ZDA050200US

No.	Mk.	Freq. MHz	Reading Level dBuV	Correct Factor dB	Measure- ment dBuV	Limit dBuV	Over dB	Detector	Comment
1		0.2575	44.70	0.00	44.70	61.51	-16.81	QP	
2		0.2575	31.25	0.00	31.25	51.51	-20.26	AVG	
3		0.3914	46.40	0.00	46.40	58.03	-11.63	QP	
4		0.3914	31.62	0.00	31.62	48.03	-16.41	AVG	
5	*	0.4550	48.50	0.00	48.50	56.78	-8.28	QP	
6		0.4550	30.30	0.00	30.30	46.78	-16.48	AVG	
7		0.6238	43.60	0.00	43.60	56.00	-12.40	QP	
8		0.6238	27.40	0.00	27.40	46.00	-18.60	AVG	
9		16.6612	43.70	0.00	43.70	60.00	-16.30	QP	
10		16.6612	35.33	0.00	35.33	50.00	-14.67	AVG	

*:Maximum data x:Over limit !:over margin Comment: Factor build in receiver. Operator:

Conducted Emission Measurement

File :BS07N(CMO)
 80.0 dBuV

Data :#28

Date: 2009-7-9

Time: 16:21:36

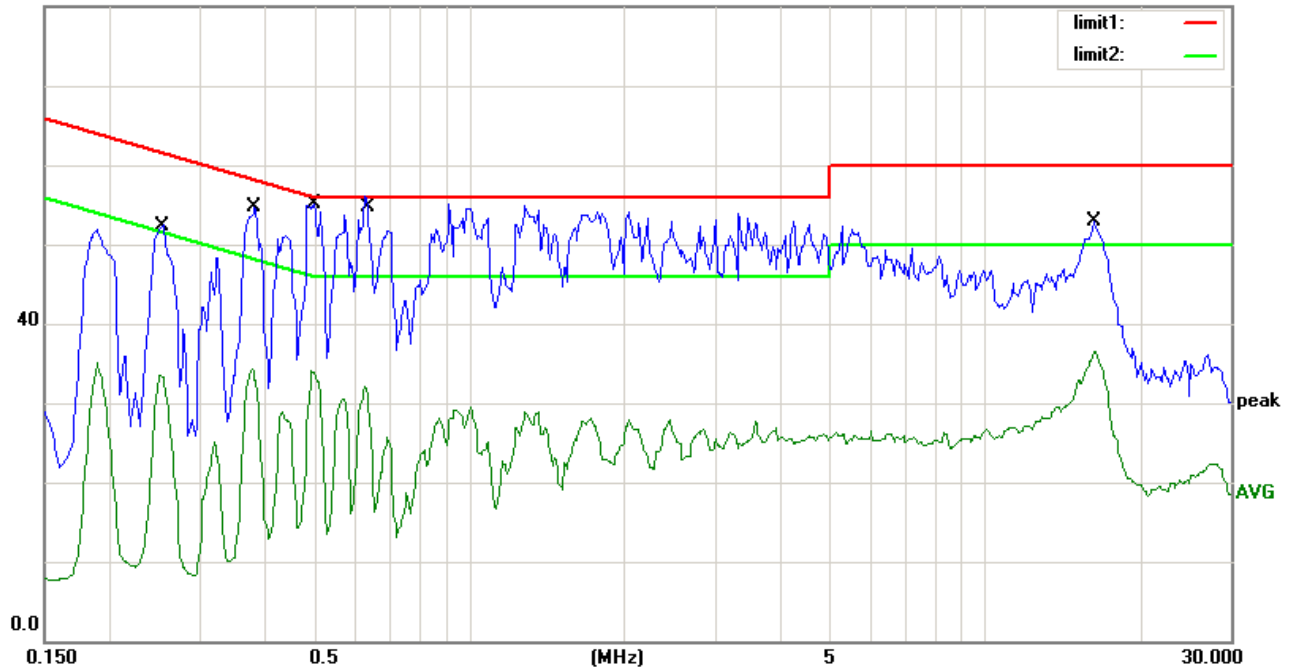

Site site #1

Phase: **N**

Temperature: 25

Limit: (CE)FCC PART 15 class B_QP

Power: AC 120V/60Hz

Humidity: 50 %

EUT: 7 INCH DIGITAL PHOTO FRAME

M/N: BS07N

Mode: SD CARD PLAYING

Note: ZDA050200US

No.	Mk.	Freq. MHz	Reading Level dBuV	Correct Factor dB	Measure- ment dBuV	Limit dBuV	Over dB	Detector	Comment
1		0.2508	46.30	0.00	46.30	61.73	-15.43	QP	
2		0.2508	33.53	0.00	33.53	51.73	-18.20	AVG	
3		0.3850	47.10	0.00	47.10	58.17	-11.07	QP	
4		0.3850	32.97	0.00	32.97	48.17	-15.20	AVG	
5	*	0.4967	47.20	0.00	47.20	56.06	-8.86	QP	
6		0.4967	34.00	0.00	34.00	46.06	-12.06	AVG	
7		0.6400	44.30	0.00	44.30	56.00	-11.70	QP	
8		0.6400	29.07	0.00	29.07	46.00	-16.93	AVG	
9		16.1400	44.80	0.00	44.80	60.00	-15.20	QP	
10		16.1400	35.87	0.00	35.87	50.00	-14.13	AVG	

*:Maximum data x:Over limit !:over margin Comment: Factor build in receiver. Operator:

Conducted Emission Measurement

File :BS07N(CMO)
 80.0 dBuV

Data :#29

Date: 2009-7-9

Time: 16:28:12

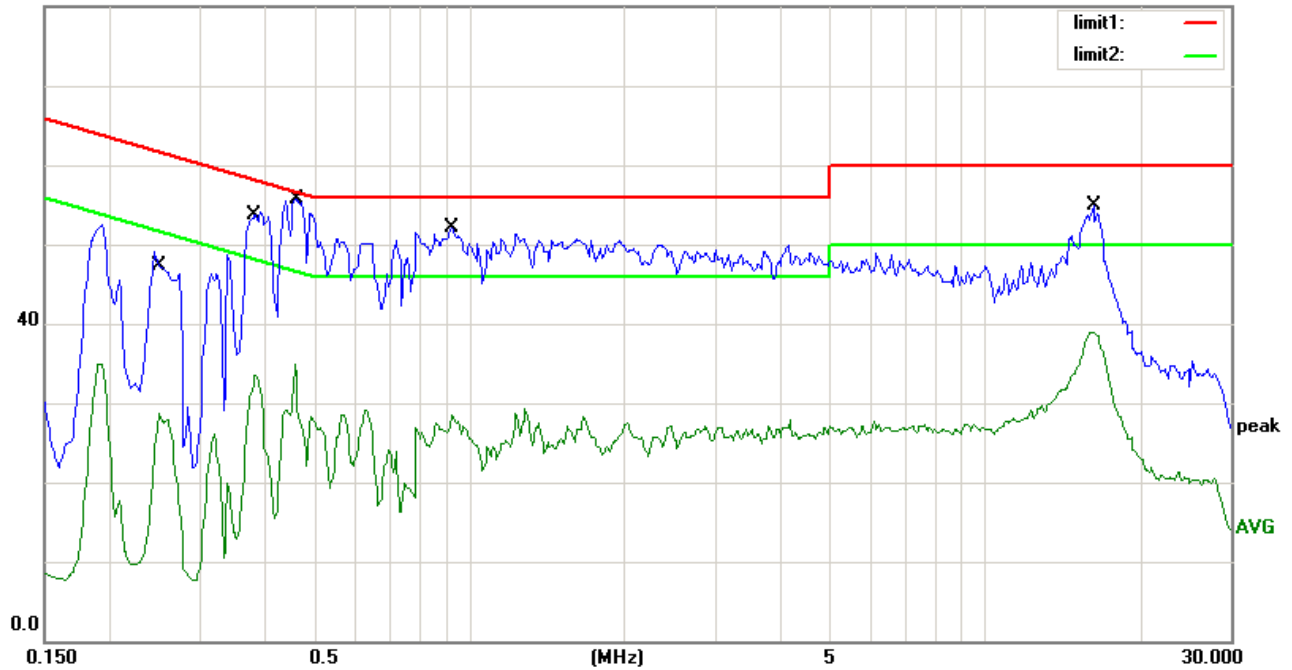

Site site #1

Phase: **L1**

Temperature: 25

Limit: (CE)FCC PART 15 class B_QP

Power: AC 120V/60Hz

Humidity: 50 %

EUT: 7 INCH DIGITAL PHOTO FRAME

M/N: BS07N

Mode: SD CARD PLAYING

Note: ZDA050200US

No.	Mk.	Freq. MHz	Reading Level dBuV	Correct Factor dB	Measure- ment dBuV	Limit dBuV	Over dB	Detector	Comment
1		0.2535	45.20	0.00	45.20	61.64	-16.44	QP	
2		0.2535	27.92	0.00	27.92	51.64	-23.72	AVG	
3		0.3871	48.80	0.00	48.80	58.13	-9.33	QP	
4		0.3871	33.25	0.00	33.25	48.13	-14.88	AVG	
5	*	0.4650	50.40	0.00	50.40	56.60	-6.20	QP	
6		0.4650	29.05	0.00	29.05	46.60	-17.55	AVG	
7		0.9331	44.40	0.00	44.40	56.00	-11.60	QP	
8		0.9331	28.09	0.00	28.09	46.00	-17.91	AVG	
9		16.0545	47.50	0.00	47.50	60.00	-12.50	QP	
10		16.0545	38.95	0.00	38.95	50.00	-11.05	AVG	

*:Maximum data x:Over limit !:over margin Comment: Factor build in receiver. Operator:

Conducted Emission Measurement

File :BS07N(CMO)
 80.0 dBuV

Data :#40

Date: 2009-7-9

Time: 18/08/32

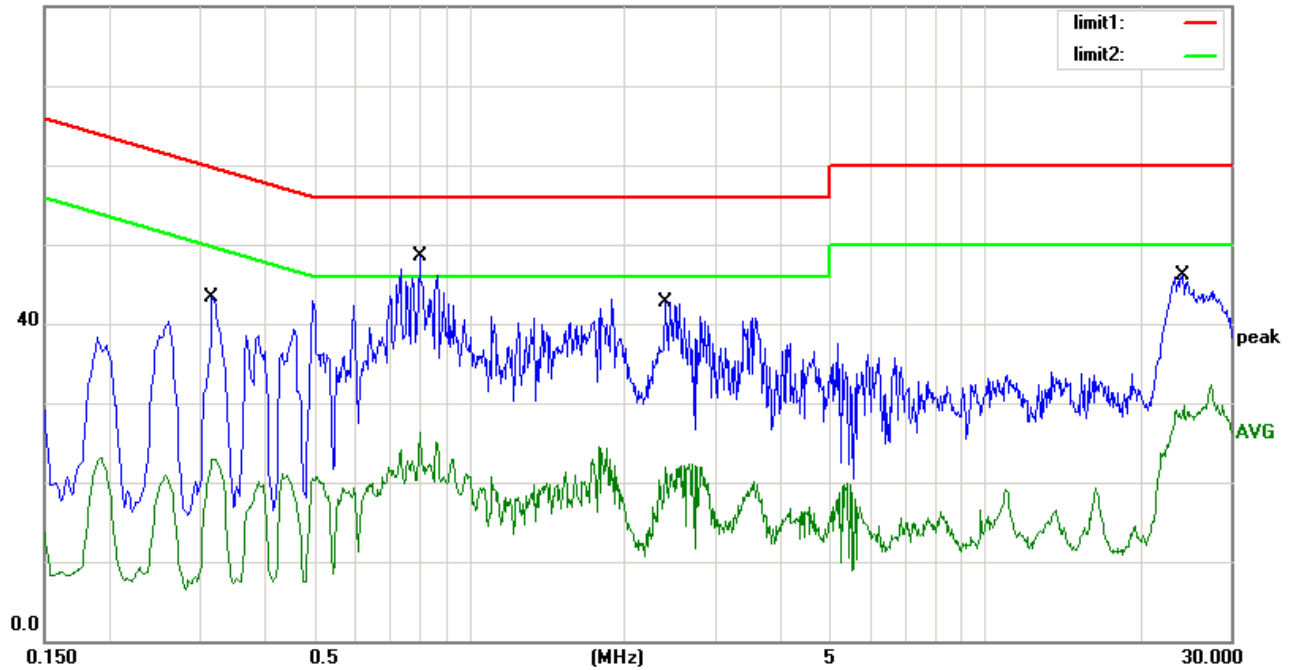

Site site #1

Phase: **N**

Temperature: 25

Limit: (CE)FCC PART 15 class B_QP

Power: AC 120V/60Hz

Humidity: 60 %

EUT: 7 INCH DIGITAL PHOTO FRAME

M/N: BS07N

Mode: CONNEC TO PC

Note: ZDA050200US

No.	Mk.	Freq. MHz	Reading Level dBuV	Correct Factor dB	Measure- ment dBuV	Limit dBuV	Over dB	Detector	Comment
1		0.3180	36.25	0.00	36.25	59.76	-23.51	QP	
2		0.3180	22.45	0.00	22.45	49.76	-27.31	AVG	
3	*	0.8020	41.45	0.00	41.45	56.00	-14.55	QP	
4		0.8020	25.65	0.00	25.65	46.00	-20.35	AVG	
5		2.4060	35.85	0.00	35.85	56.00	-20.15	QP	
6		2.4060	21.15	0.00	21.15	46.00	-24.85	AVG	
7		24.1740	38.25	0.00	38.25	60.00	-21.75	QP	
8		24.1740	27.45	0.00	27.45	50.00	-22.55	AVG	

*:Maximum data x:Over limit !:over margin Comment: Factor build in receiver. Operator:

Conducted Emission Measurement

File :BS07N(CMO)
 80.0 dBuV

Data :#41

Date: 2009-7-9

Time: 18/11/09

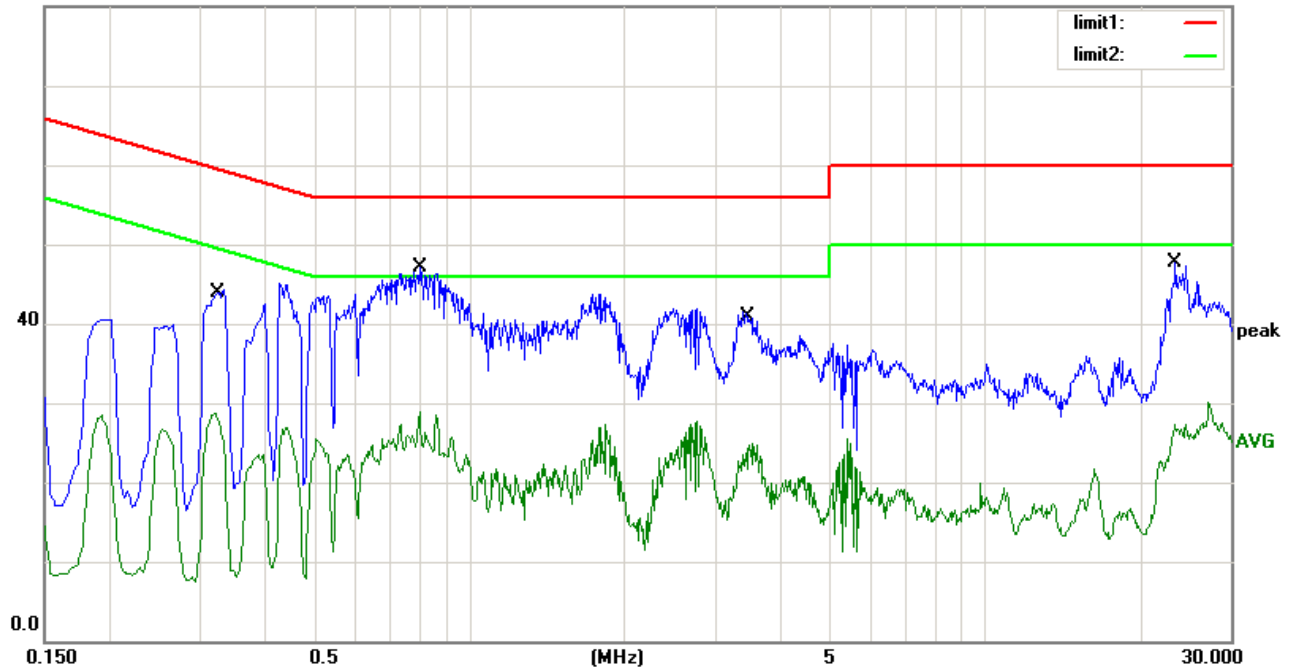

Site site #1

Phase: **L1**

Temperature: 25

Limit: (CE)FCC PART 15 class B_QP

Power: AC 120V/60Hz

Humidity: 60 %

EUT: 7 INCH DIGITAL PHOTO FRAME

M/N: BS07N

Mode: CONNECT TO PC

Note: ZDA050200US

No.	Mk.	Freq. MHz	Reading Level dBuV	Correct Factor dB	Measure- ment dBuV	Limit dBuV	Over dB	Detector	Comment
1		0.3260	41.15	0.00	41.15	59.55	-18.40	QP	
2		0.3260	28.15	0.00	28.15	49.55	-21.40	AVG	
3	*	0.8020	45.05	0.00	45.05	56.00	-10.95	QP	
4		0.8020	29.25	0.00	29.25	46.00	-16.75	AVG	
5		3.4740	38.75	0.00	38.75	56.00	-17.25	QP	
6		3.4740	23.75	0.00	23.75	46.00	-22.25	AVG	
7		23.3940	36.55	0.00	36.55	60.00	-23.45	QP	
8		23.3940	24.85	0.00	24.85	50.00	-25.15	AVG	

*:Maximum data x:Over limit !:over margin Comment: Factor build in receiver. Operator:

Adapter XKD-C2000IC5.0-12W used for test.

Conducted Emission Measurement

File :BS07N(CMO)
 80.0 dBuV

Data :#30

Date: 2009-7-9

Time: 16:35:48

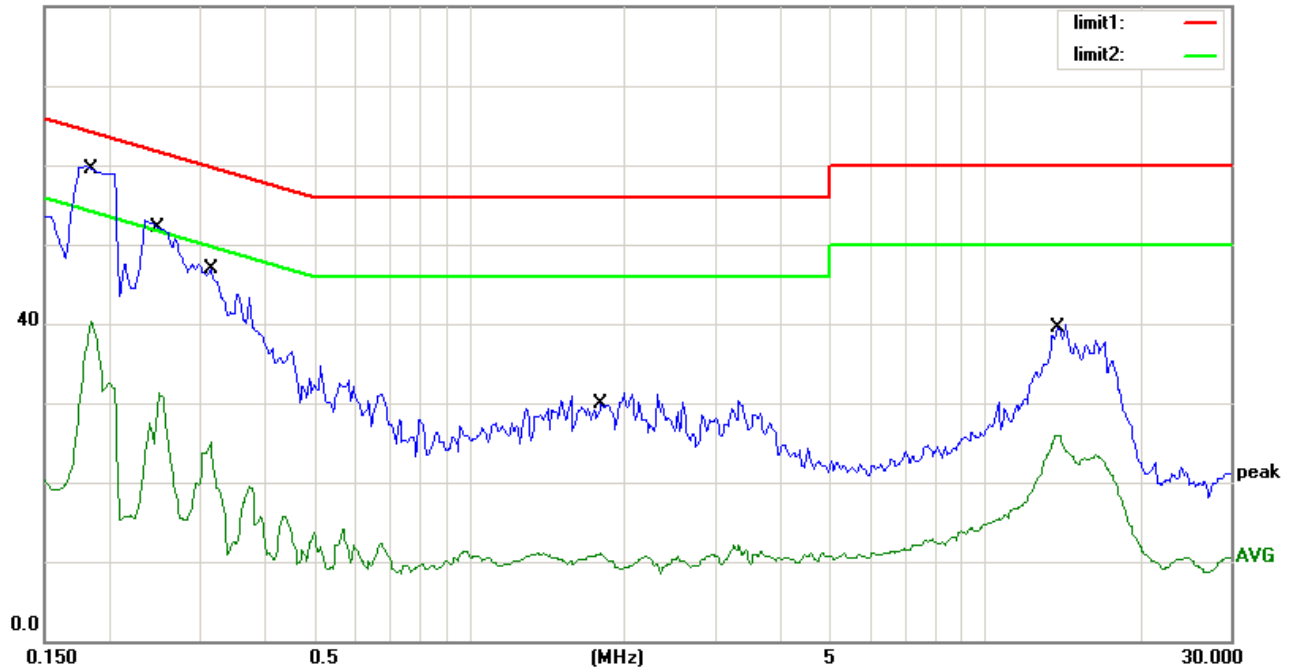

Site site #1

Phase: **L1**

Temperature: 25

Limit: (CE)FCC PART 15 class B_QP

Power: AC 120V/60Hz

Humidity: 50 %

EUT: 7 INCH DIGITAL PHOTO FRAME

M/N: BS07N

Mode: SD CARD PLAYING

Note: XKD-C2000IC5.0-12W

No.	Mk.	Freq. MHz	Reading Level dBuV	Correct Factor dB	Measure- ment dBuV	Limit dBuV	Over dB	Detector	Comment
1	*	0.1864	55.90	0.00	55.90	64.20	-8.30	QP	
2		0.1864	40.46	0.00	40.46	54.20	-13.74	AVG	
3		0.2508	48.30	0.00	48.30	61.73	-13.43	QP	
4		0.2508	42.00	0.00	42.00	51.73	-9.73	AVG	
5		0.3133	42.10	0.00	42.10	59.88	-17.78	QP	
6		0.3133	32.59	0.00	32.59	49.88	-17.29	AVG	
7		1.8096	18.50	0.00	18.50	56.00	-37.50	QP	
8		1.8096	22.75	0.00	22.75	46.00	-23.25	AVG	
9		13.7680	32.90	0.00	32.90	60.00	-27.10	QP	
10		13.7680	38.95	0.00	38.95	50.00	-11.05	AVG	

*:Maximum data x:Over limit !:over margin Comment: Factor build in receiver. Operator:

Conducted Emission Measurement

File :BS07N(CMO)
 80.0 dBuV

Data :#31

Date: 2009-7-9

Time: 16:46:00

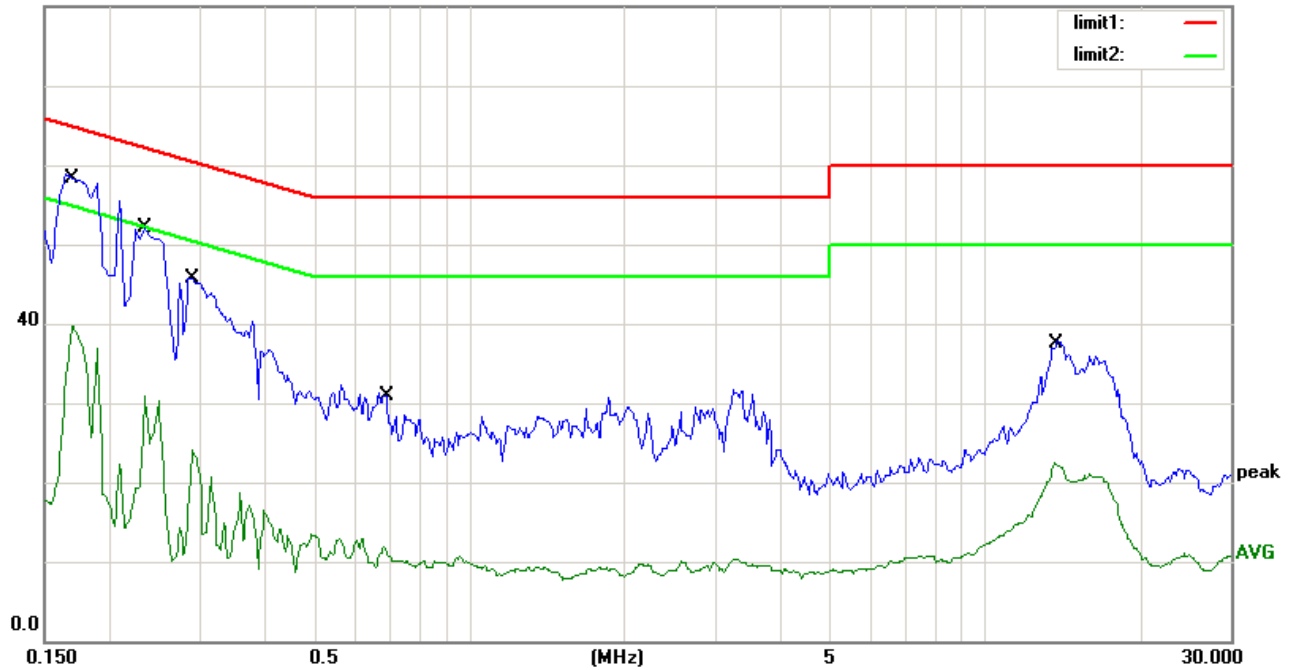

Site site #1

Phase: **N**

Temperature: 25

Limit: (CE)FCC PART 15 class B_QP

Power: AC 120V/60Hz

Humidity: 50 %

EUT: 7 INCH DIGITAL PHOTO FRAME

M/N: BS07N

Mode: SD CARD PLAYING

Note: XKD-C2000IC5.0-12W

No.	Mk.	Freq. MHz	Reading Level dBuV	Correct Factor dB	Measure- ment dBuV	Limit dBuV	Over dB	Detector	Comment
1	*	0.1712	55.40	0.00	55.40	64.90	-9.50	QP	
2		0.1712	39.37	0.00	39.37	54.90	-15.53	AVG	
3		0.2353	48.60	0.00	48.60	62.26	-13.66	QP	
4		0.2353	30.46	0.00	30.46	52.26	-21.80	AVG	
5		0.2878	43.50	0.00	43.50	60.59	-17.09	QP	
6		0.2878	20.72	0.00	20.72	50.59	-29.87	AVG	
7		0.6863	25.50	0.00	25.50	56.00	-30.50	QP	
8		0.6863	11.72	0.00	11.72	46.00	-34.28	AVG	
9		13.5510	29.60	0.00	29.60	60.00	-30.40	QP	
10		13.5510	21.88	0.00	21.88	50.00	-28.12	AVG	

*:Maximum data x:Over limit !:over margin Comment: Factor build in receiver. Operator:

Conducted Emission Measurement

File :BS07N(CMO)
 80.0 dBuV

Data :#32

Date: 2009-7-9

Time: 16:52:55

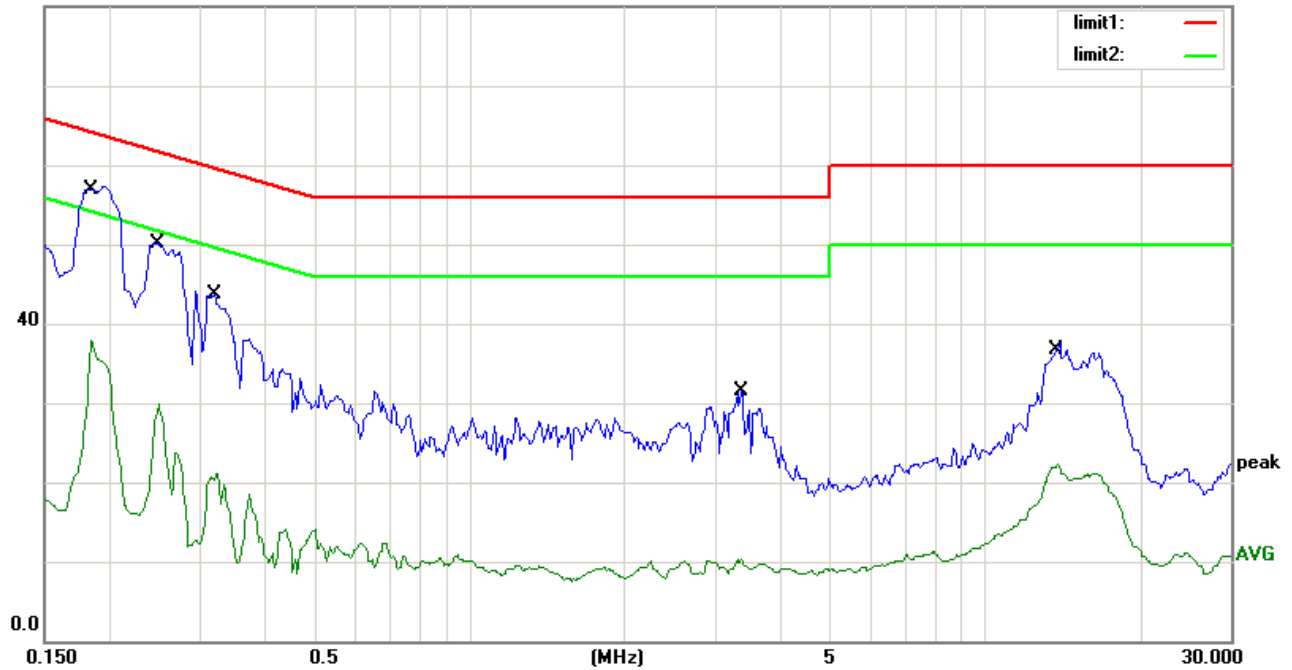

Site site #1

Phase: **N**

Temperature: 25

Limit: (CE)FCC PART 15 class B_QP

Power: AC 120V/60Hz

Humidity: 50 %

EUT: 7 INCH DIGITAL PHOTO FRAME

M/N: BS07N

Mode: USB PLAYING

Note: XKD-C2000IC5.0-12W

No.	Mk.	Freq. MHz	Reading Level dBuV	Correct Factor dB	Measure- ment dBuV	Limit dBuV	Over dB	Detector	Comment
1	*	0.1864	52.00	0.00	52.00	64.20	-12.20	QP	
2		0.1864	37.21	0.00	37.21	54.20	-16.99	AVG	
3		0.2508	46.20	0.00	46.20	61.73	-15.53	QP	
4		0.2508	29.40	0.00	29.40	51.73	-22.33	AVG	
5		0.3200	39.30	0.00	39.30	59.71	-20.41	QP	
6		0.3200	20.34	0.00	20.34	49.71	-29.37	AVG	
7		3.3800	23.00	0.00	23.00	56.00	-33.00	QP	
8		3.3800	10.22	0.00	10.22	46.00	-35.78	AVG	
9		13.6228	29.60	0.00	29.60	60.00	-30.40	QP	
10		13.6228	21.90	0.00	21.90	50.00	-28.10	AVG	

*:Maximum data x:Over limit !:over margin Comment: Factor build in receiver. Operator:

Conducted Emission Measurement

File :BS07N(CMO)

Data :#33

Date: 2009-7-9

Time: 17:00:02

80.0 dBuV

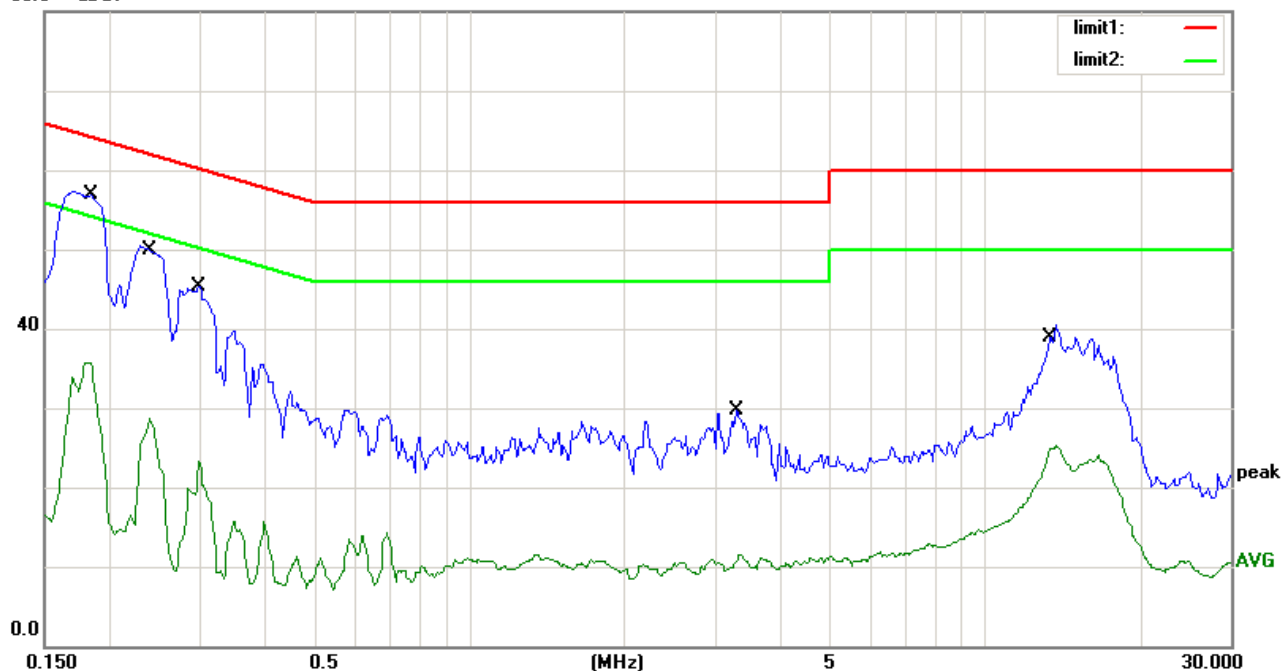

Site site #1

Phase: **L1**

Temperature: 25

Limit: (CE)FCC PART 15 class B_QP

Power: AC 120V/60Hz

Humidity: 50 %

EUT: 7 INCH DIGITAL PHOTO FRAME

M/N: BS07N

Mode: USB PLAYING

Note: XKD-C2000IC5.0-12W

No.	Mk.	Freq. MHz	Reading Level dBuV	Correct Factor dB	Measure- ment dBuV	Limit dBuV	Over dB	Detector	Comment
1	*	0.1835	54.00	0.00	54.00	64.33	-10.33	QP	
2		0.1835	35.71	0.00	35.71	54.33	-18.62	AVG	
3		0.2416	47.00	0.00	47.00	62.04	-15.04	QP	
4		0.2416	28.24	0.00	28.24	52.04	-23.80	AVG	
5		0.3003	41.40	0.00	41.40	60.23	-18.83	QP	
6		0.3003	23.08	0.00	23.08	50.23	-27.15	AVG	
7		3.2756	18.70	0.00	18.70	56.00	-37.30	QP	
8		3.2756	10.40	0.00	10.40	46.00	-35.60	AVG	
9		13.3750	32.10	0.00	32.10	60.00	-27.90	QP	
10		13.3750	24.91	0.00	24.91	50.00	-25.09	AVG	

*:Maximum data x:Over limit !:over margin Comment: Factor build in receiver. Operator:

Conducted Emission Measurement

File :BS07N(CMO)
 80.0 dBuV

Data :#34

Date: 2009-7-9

Time: 17:06:14

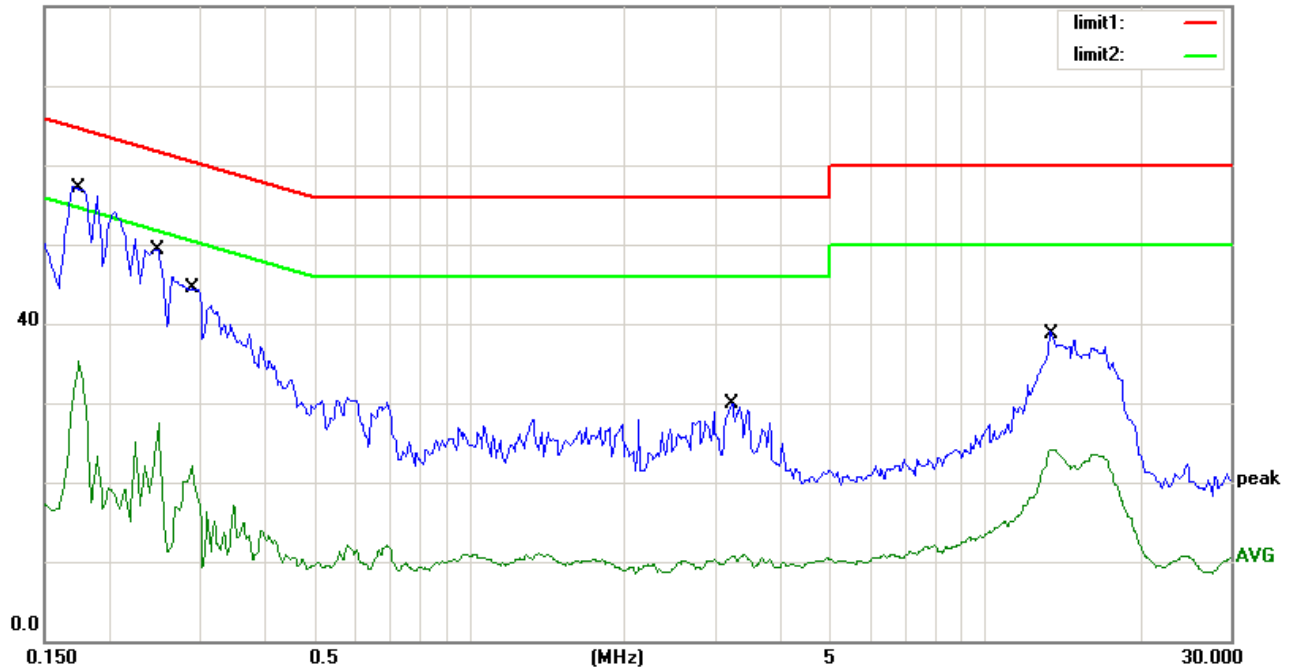

Site site #1

Phase: **L1**

Temperature: 25

Limit: (CE)FCC PART 15 class B_QP

Power: AC 120V/60Hz

Humidity: 50 %

EUT: 7 INCH DIGITAL PHOTO FRAME

M/N: BS07N

Mode: Memorying

Note: XKD-C2000IC5.0-12W

No.	Mk.	Freq. MHz	Reading Level dBuV	Correct Factor dB	Measure- ment dBuV	Limit dBuV	Over dB	Detector	Comment
1	*	0.1750	54.30	0.00	54.30	64.72	-10.42	QP	
2		0.1750	35.10	0.00	35.10	54.72	-19.62	AVG	
3		0.2481	43.50	0.00	43.50	61.82	-18.32	QP	
4		0.2481	22.80	0.00	22.80	51.82	-29.02	AVG	
5		0.2910	41.50	0.00	41.50	60.50	-19.00	QP	
6		0.2910	23.10	0.00	23.10	50.50	-27.40	AVG	
7		3.2400	16.40	0.00	16.40	56.00	-39.60	QP	
8		3.2400	9.20	0.00	9.20	46.00	-36.80	AVG	
9		13.6228	31.70	0.00	31.70	60.00	-28.30	QP	
10		13.6228	23.90	0.00	23.90	50.00	-26.10	AVG	

*:Maximum data x:Over limit !:over margin Comment: Factor build in receiver. Operator:

Conducted Emission Measurement

File :BS07N(CMO)
 80.0 dBuV

Data :#35

Date: 2009-7-9

Time: 17:21:48

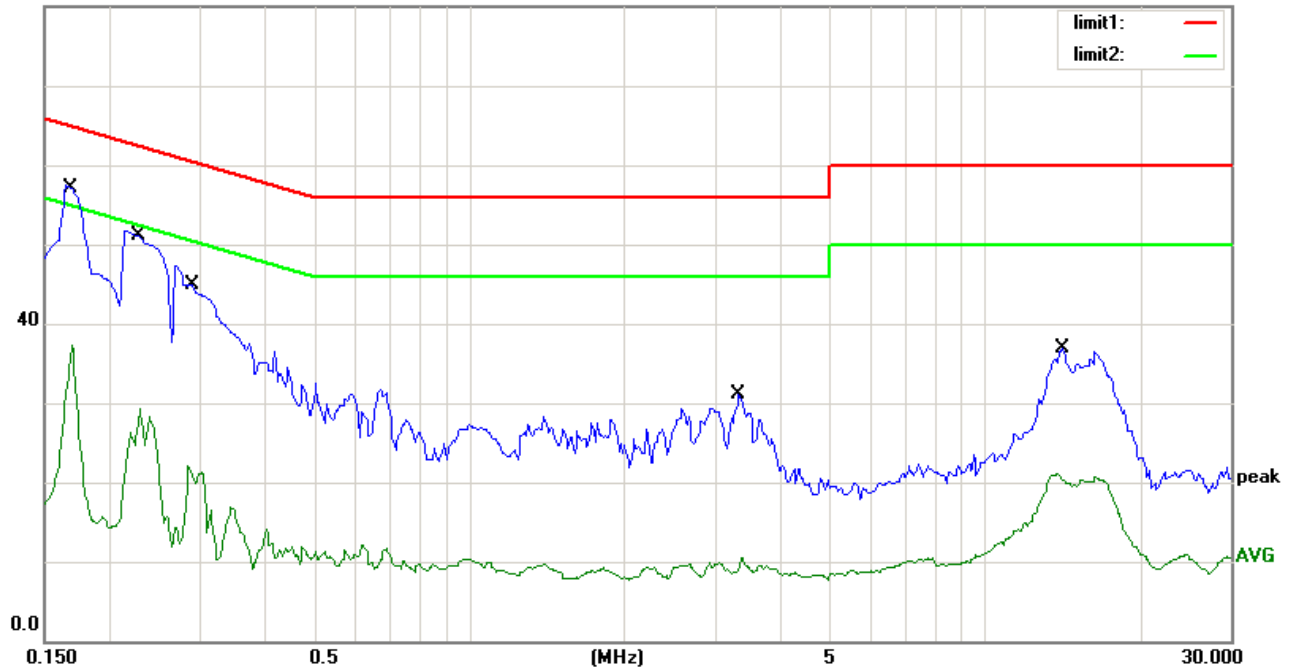

Site site #1

Phase: **N**

Temperature: 25

Limit: (CE)FCC PART 15 class B_QP

Power: AC 120V/60Hz

Humidity: 50 %

EUT: 7 INCH DIGITAL PHOTO FRAME

M/N: BS07N

Mode: Memorying

Note: XKD-C2000IC5.0-12W

No.	Mk.	Freq. MHz	Reading Level dBuV	Correct Factor dB	Measure- ment dBuV	Limit dBuV	Over dB	Detector	Comment
1	*	0.1700	54.90	0.00	54.90	64.96	-10.06	QP	
2		0.1700	37.29	0.00	37.29	54.96	-17.67	AVG	
3		0.2304	48.30	0.00	48.30	62.44	-14.14	QP	
4		0.2304	28.91	0.00	28.91	52.44	-23.53	AVG	
5		0.2910	41.70	0.00	41.70	60.50	-18.80	QP	
6		0.2910	20.67	0.00	20.67	50.50	-29.83	AVG	
7		3.3458	21.40	0.00	21.40	56.00	-34.60	QP	
8		3.3458	9.21	0.00	9.21	46.00	-36.79	AVG	
9		14.1750	28.40	0.00	28.40	60.00	-31.60	QP	
10		14.1750	20.39	0.00	20.39	50.00	-29.61	AVG	

*:Maximum data x:Over limit !:over margin Comment: Factor build in receiver. Operator:

Conducted Emission Measurement

File :BS07N(CMO)
 80.0 dBuV

Data :#36

Date: 2009-7-9

Time: 17:39:47

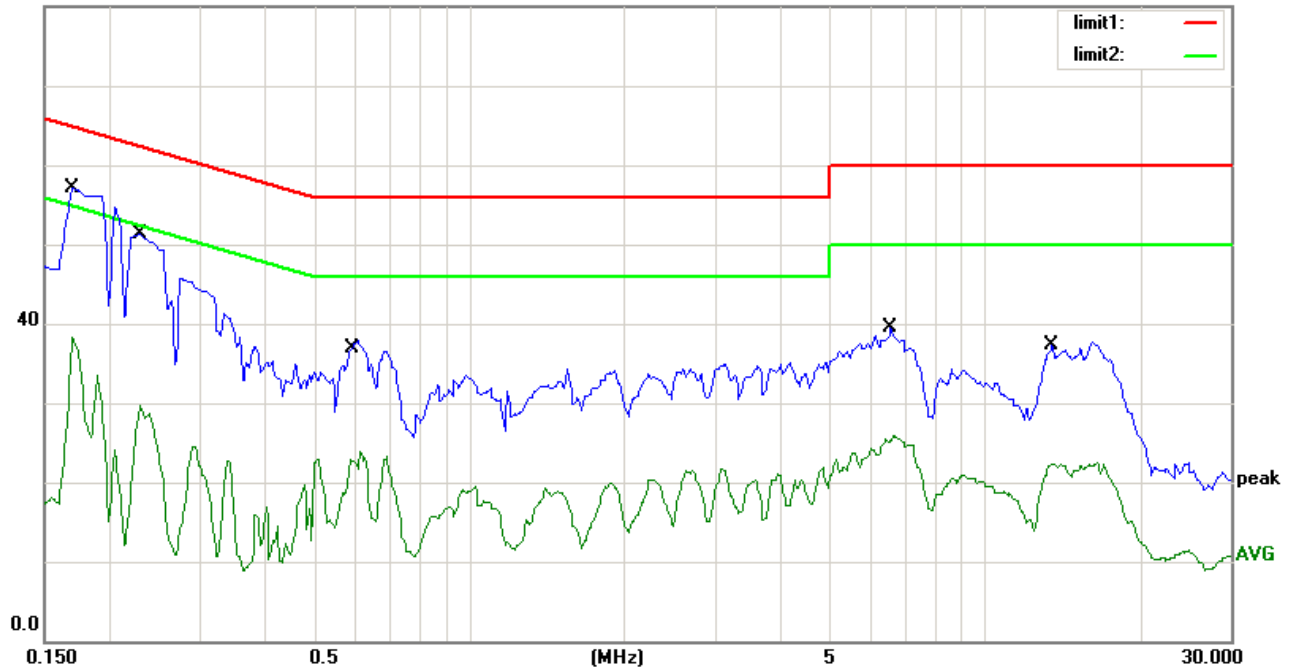

Site site #1

Phase: **N**

Temperature: 25

Limit: (CE)FCC PART 15 class B_QP

Power: AC 120V/60Hz

Humidity: 50 %

EUT: 7 INCH DIGITAL PHOTO FRAME

M/N: BS07N

Mode: CONNECT TO PC

Note: XKD-C2000IC5.0-12W

No.	Mk.	Freq. MHz	Reading Level dBuV	Correct Factor dB	Measure- ment dBuV	Limit dBuV	Over dB	Detector	Comment
1	*	0.1700	54.60	0.00	54.60	64.96	-10.36	QP	
2		0.1700	38.21	0.00	38.21	54.96	-16.75	AVG	
3		0.2280	48.00	0.00	48.00	62.52	-14.52	QP	
4		0.2280	28.18	0.00	28.18	52.52	-24.34	AVG	
5		0.5854	32.90	0.00	32.90	56.00	-23.10	QP	
6		0.5854	21.49	0.00	21.49	46.00	-24.51	AVG	
7		6.5921	33.40	0.00	33.40	60.00	-26.60	QP	
8		6.5921	25.35	0.00	25.35	50.00	-24.65	AVG	
9		13.5510	31.20	0.00	31.20	60.00	-28.80	QP	
10		13.5510	22.34	0.00	22.34	50.00	-27.66	AVG	

*:Maximum data x:Over limit !:over margin Comment: Factor build in receiver. Operator:

Conducted Emission Measurement

File :BS07N(CMO)
 80.0 dBuV

Data :#37

Date: 2009-7-9

Time: 17:46:10

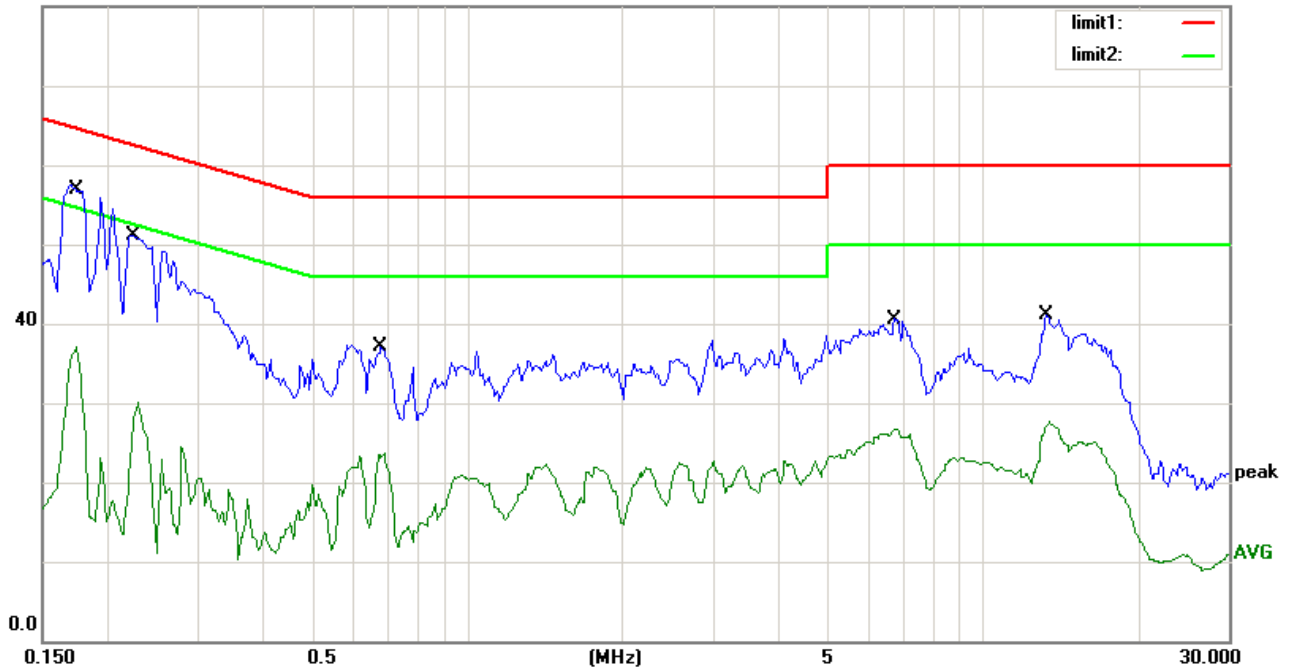

Site site #1

Phase: **L1**

Temperature: 25

Limit: (CE)FCC PART 15 class B_QP

Power: AC 120V/60Hz

Humidity: 50 %

EUT: 7 INCH DIGITAL PHOTO FRAME

M/N: BS07N

Mode: CONNECT TO PC

Note: XKD-C2000IC5.0-12W

No.	Mk.	Freq. MHz	Reading Level dBuV	Correct Factor dB	Measure- ment dBuV	Limit dBuV	Over dB	Detector	Comment
1	*	0.1750	53.90	0.00	53.90	64.72	-10.82	QP	
2		0.1750	37.17	0.00	37.17	54.72	-17.55	AVG	
3		0.2280	47.50	0.00	47.50	62.52	-15.02	QP	
4		0.2280	29.17	0.00	29.17	52.52	-23.35	AVG	
5		0.6826	33.40	0.00	33.40	56.00	-22.60	QP	
6		0.6826	23.31	0.00	23.31	46.00	-22.69	AVG	
7		6.7691	33.60	0.00	33.60	60.00	-26.40	QP	
8		6.7691	26.69	0.00	26.69	50.00	-23.31	AVG	
9		13.3372	34.10	0.00	34.10	60.00	-25.90	QP	
10		13.3372	27.29	0.00	27.29	50.00	-22.71	AVG	

*:Maximum data x:Over limit !:over margin Comment: Factor build in receiver. Operator:

3. RADIATED EMISSION MEASUREMENT

3.1. Test Equipment

The following test equipments are used during the radiated emission measurement:

3.1.1. For Anechoic Chamber

Item	Equipment	Manufacturer	Model No.	Serial No.	Last Cal.	Cal. Interval
1.	Spectrum Analyzer	Rohde & Schwarz	ESCI	100137	May 20, 2009	1 Year
2.	Test Receiver	Rohde & Schwarz	ESCI	100137	May 20, 2009	1 Year
3.	Bilog Antenna	Schwarzbeck	VULB9163	143	May 20, 2009	1 Year
4.	Power Amplifier	HP	8447F	OPT H64	May 20, 2009	1 Year
5.	Positioning Controller	C&C LAB	CC-C-IF	N/A	May 20, 2009	1 Year
6.	Color Monitor	SUNSPO	SP-140A	N/A	May 20, 2009	1 Year
7.	Single Line Filter	JIANLI	XL-3	N/A	May 20, 2009	1 Year
8.	Single Phase Power Line Filter	JIANLI	DL-2X100B	N/A	May 20, 2009	1 Year
9.	3 Phase Power Line Filter	JIANLI	DL-4X100B	N/A	May 20, 2009	1 Year
10.	DC Power Filter	JIANLI	DL-2X50B	N/A	May 20, 2009	1 Year
11.	Cable	Schwarzbeck	PLF-100	N/A	May 20, 2009	1 Year
12.	Cable	Rosenberger	CIL02	A0783566	May 20, 2009	1 Year
13.	Cable	Rosenberger	AK9513	AC RX1	May 20, 2009	1 Year

3.2. Block Diagram of Test Setup

3.2.1. Block diagram of connection between the EUT and simulators

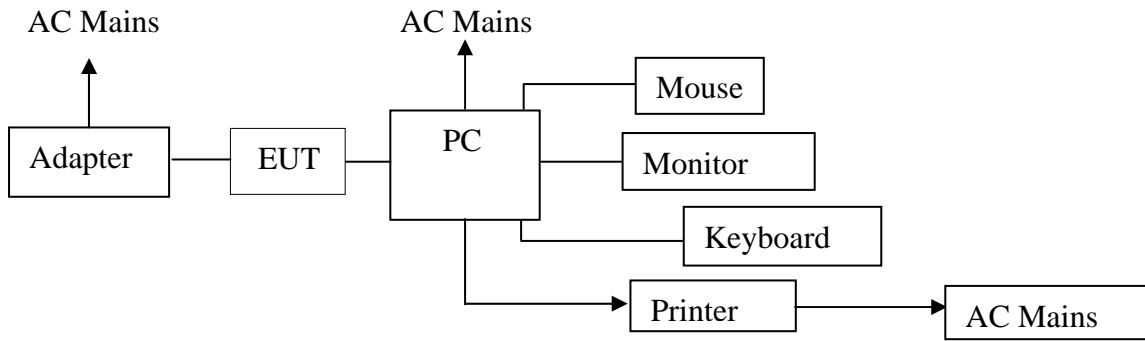

(EUT: 7 inch Digital Photo Frame)

3.2.2. Anechoic Chamber Test Setup Diagram

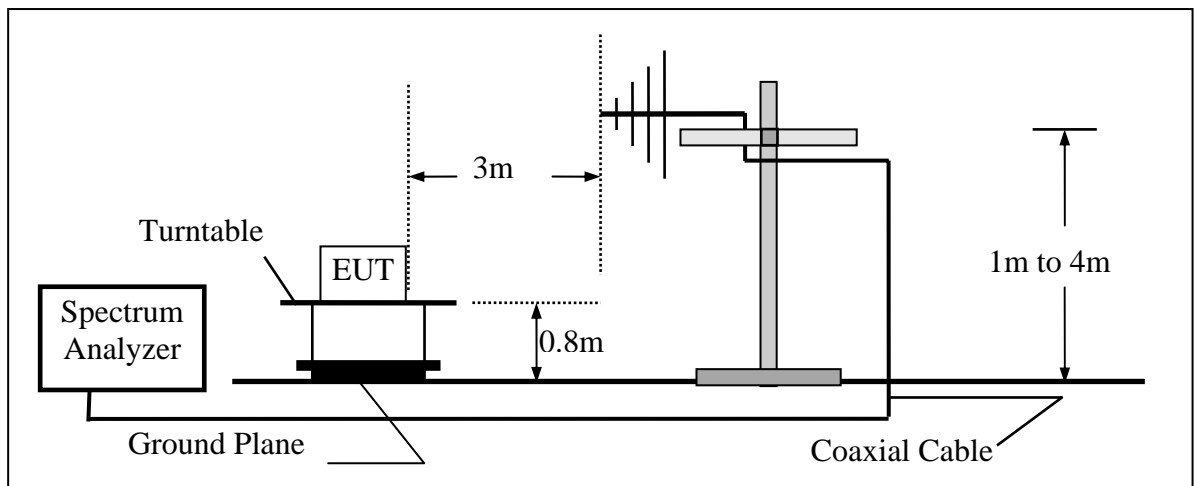

(EUT: 7 inch Digital Photo Frame)

3.3. Radiated Emission Limit

Radiated Emission Limits is as following.

FREQUENCY MHz	DISTANCE Meters	FIELD STRENGTHS LIMIT
		dB(μV)/m
30 ~ 88	3	40.0
88 ~ 216	3	43.5
216 ~ 960	3	46.0
960 ~ 1000	3	54.0
>1000	3	74.0 dB(μV)/m (peak) 54.0 dB(μV)/m (Average)

- Remark :
- (1) Emission level (dB)μV = 20 log Emission level μV/m
 - (2) The smaller limit shall apply at the cross point between two frequency bands.
 - (3) Distance is the distance in meters between the measuring instrument, antenna and the closest point of any part of the device or system.

3.4.EUT Configuration on Measurement

The following equipment are installed on Radiated Emission Measurement to meet the commission requirements and operating regulations in a manner which tends to maximize its emission characteristics in normal application.

7 inch Digital Photo Frame (EUT)

Model Number : BS07N

3.5.Operating Condition of EUT

3.5.1 Setup the EUT as shown in Section 3.2.

3.5.2 Turn on the power of all equipment.

3.5.3 Let the EUT work in test mode (Memorying, SD Card Playing, USB Playing, Connect to PC) and measure it.

3.6.Test Procedure

EUT and its simulators are placed on a turntable, which is 0.8 meter high above ground. The turn table can rotate 360 degrees to determine the position of the maximum emission level. EUT is set 3.0 meters away from the receiving antenna, which is mounted on a antenna tower. The antenna can be moved up and down between 1.0 meter and 4 meters to find out the maximum emission level. Broadband antenna (calibrated bilog antenna) is used as receiving antenna. Both horizontal and vertical polarization of the antenna is set on measurement. In order to find the maximum emission levels, all of the interface cables must be manipulated according to ANSI C63.4-2003 on radiated emission measurement.

The bandwidth of the EMI test receiver (R&S ESCI) set at 120KHz in 30MHz to 1000MHz, set at 1MHz above 1000MHz.

The frequency range from 30MHz to 1000MHz is checked.

3.7.Radiated Emission Noise Measurement Results

PASS.

The scanning waveforms refer to the following pages:

Adapter ADS-12G-0605010GPCU used for test.

Radiated Emission Measurement

File :BS07N(AUO)

Data :#9

Date: 09/07/10/

Time: 11/09/52

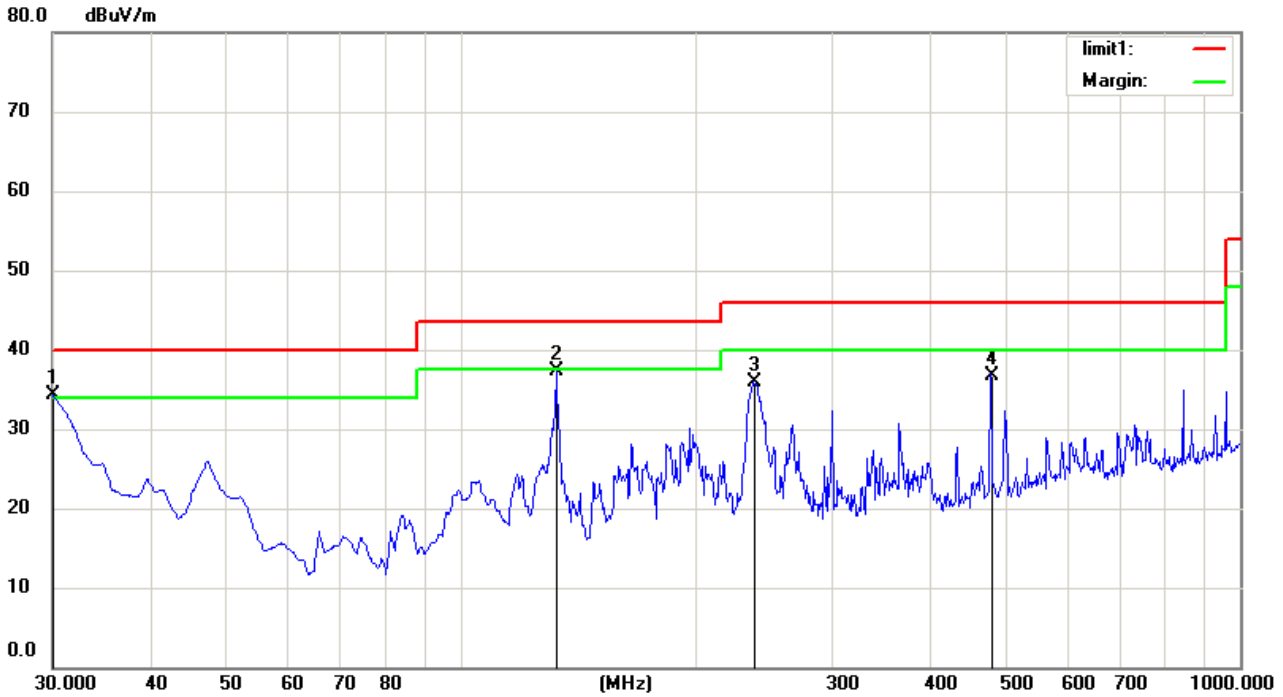

Site Chamber #1

Polarization: **Vertical**

Temperature: 26

Limit: (RE)FCC PART 15 class B 3m

Power: AC 120V/60Hz

Humidity: 55 %

EUT: 7INCH DIGITAL PHOTO FRAME

M/N: BS07N

Mode: Memorying

Note: ADS-12G-06 05010GPCU

No.	Mk.	Freq.	Reading Level	Correct Factor	Measurement	Limit	Over	Antenna Height	Table Degree	
		MHz	dBuV	dB	dBuV/m	dBuV/m	dB	Detector	cm	degree
1	*	30.0000	51.38	-17.15	34.23	40.00	-5.77	QP		
2		132.8200	57.71	-20.50	37.21	43.50	-6.29	QP		
3		237.5800	48.06	-12.18	35.88	46.00	-10.12	QP		
4		480.0800	44.40	-7.60	36.80	46.00	-9.20	QP		

*:Maximum data x:Over limit !:over margin

Operator:

Radiated Emission Measurement

File :BS07N(AUO)

Data :#10

Date: 09/07/10/

Time: 11/11/34

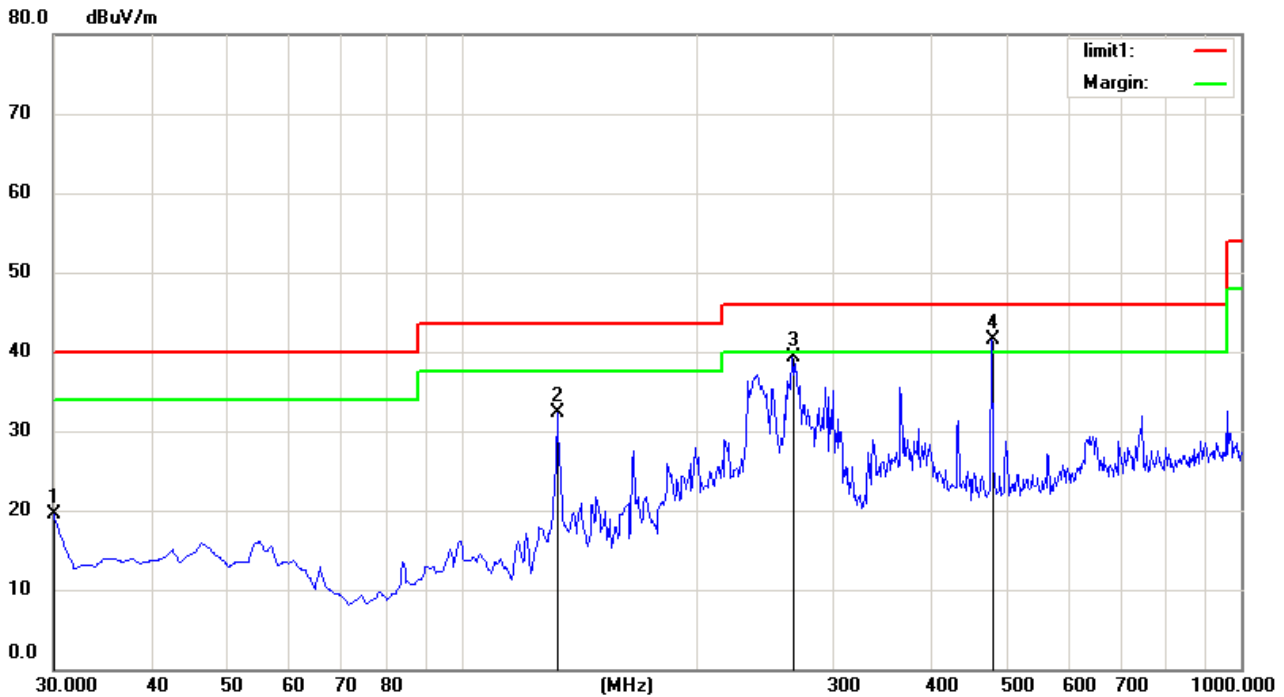

Site Chamber #1

Polarization: **Horizontal**

Temperature: 26

Limit: (RE)FCC PART 15 class B 3m

Power: AC 120V/60Hz

Humidity: 55 %

EUT: 7INCH DIGITAL PHOTO FRAME

M/N: BS07N

Mode:Memorying

Note: ADS-12G-0605010GPCU

No.	Mk.	Freq.	Reading Level	Correct Factor	Measurement	Limit	Over	Antenna Height	Table Degree	
		MHz	dBuV	dB	dBuV/m	dBuV/m	dB	cm	degree	Comment
1		30.0000	36.64	-17.15	19.49	40.00	-20.51	QP		
2		132.8200	52.85	-20.50	32.35	43.50	-11.15	QP		
3		265.7100	51.11	-11.81	39.30	46.00	-6.70	QP		
4	*	480.0800	49.06	-7.60	41.46	46.00	-4.54	QP		

*:Maximum data x:Over limit !:over margin

Operator:

Radiated Emission Measurement

File :BS07N(AUO)

Data :#11

Date: 09/07/10/

Time: 11/15/55

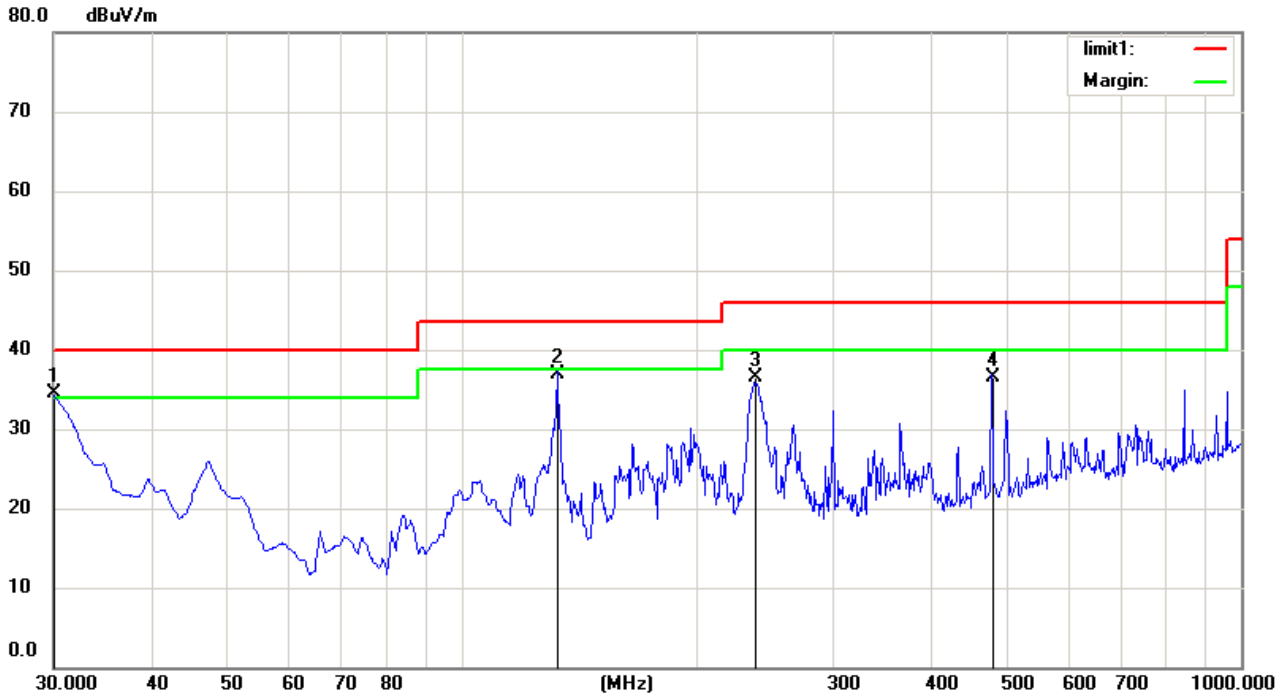

Site Chamber #1

Polarization: **Vertical**

Temperature: 26

Limit: (RE)FCC PART 15 class B 3m

Power: AC 120V/60Hz

Humidity: 55 %

EUT: 7INCH DIGITAL PHOTO FRAME

M/N: BS07N

Mode:SD CARD PLAYING

Note: ADS-12G-0605010GPCU

No.	Mk.	Freq.	Reading Level	Correct Factor	Measurement	Limit	Over	Antenna Height	Table Degree		
		MHz	dBuV	dB	dBuV/m	dBuV/m	dB	Detector	cm	degree	Comment
1	*	30.0000	51.65	-17.15	34.50	40.00	-5.50	QP			
2		132.8200	57.32	-20.50	36.82	43.50	-6.68	QP			
3		237.5800	48.76	-12.18	36.58	46.00	-9.42	QP			
4		480.0800	44.20	-7.60	36.60	46.00	-9.40	QP			

*:Maximum data x:Over limit !:over margin

Operator:

Radiated Emission Measurement

File :BS07N(AUO)

Data :#12

Date: 09/07/10/

Time: 11/19/23

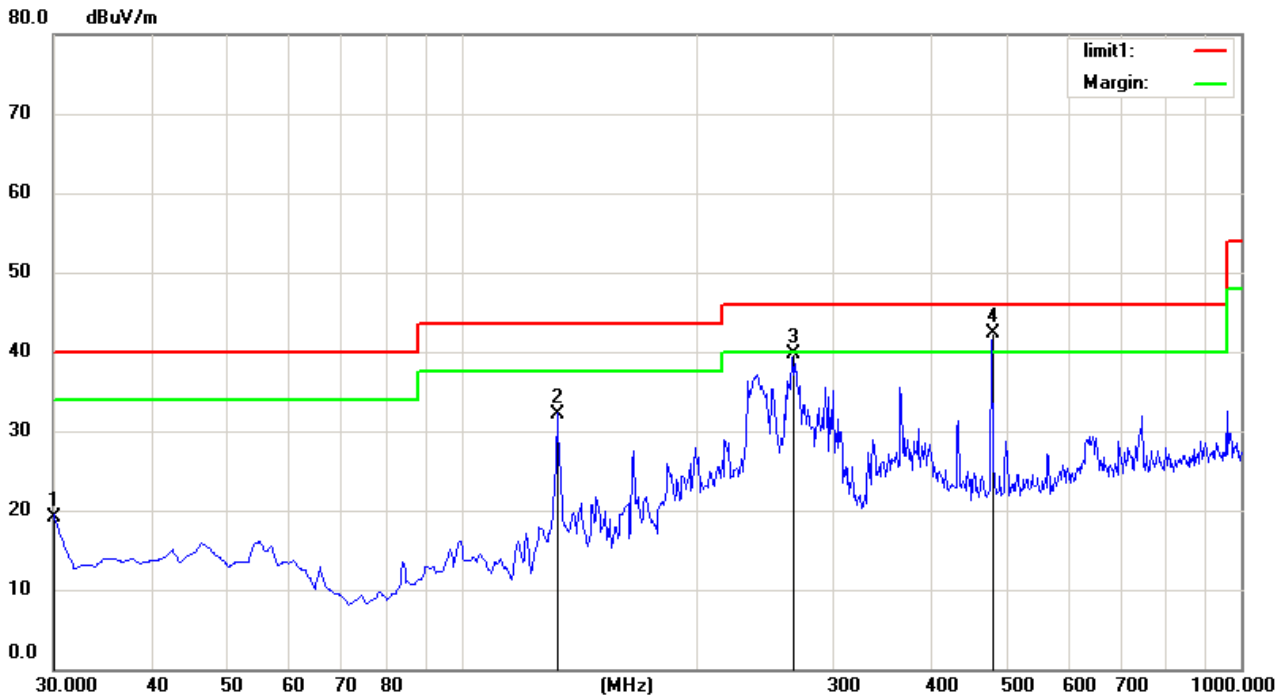

Site Chamber #1

Polarization: **Horizontal**

Temperature: 26

Limit: (RE)FCC PART 15 class B 3m

Power: AC 120V/60Hz

Humidity: 55 %

EUT: 7INCH DIGITAL PHOTO FRAME

M/N: BS07N

Mode:SD CARD PLAYING

Note: ADS-12G-0605010GPCU

No.	Mk.	Freq.	Reading Level	Correct Factor	Measurement	Limit	Over	Antenna Height	Table Degree	Comment
		MHz	dBuV	dB	dBuV/m	dBuV/m	dB	cm	degree	
1		30.0000	36.18	-17.15	19.03	40.00	-20.97	QP		
2		132.8200	52.67	-20.50	32.17	43.50	-11.33	QP		
3		265.7100	51.46	-11.81	39.65	46.00	-6.35	QP		
4	*	480.0800	49.85	-7.60	42.25	46.00	-3.75	QP		

*:Maximum data x:Over limit !:over margin

Operator:

Radiated Emission Measurement

File :BS07N(AUO)

Data :#13

Date: 09/07/10/

Time: 11/24/57

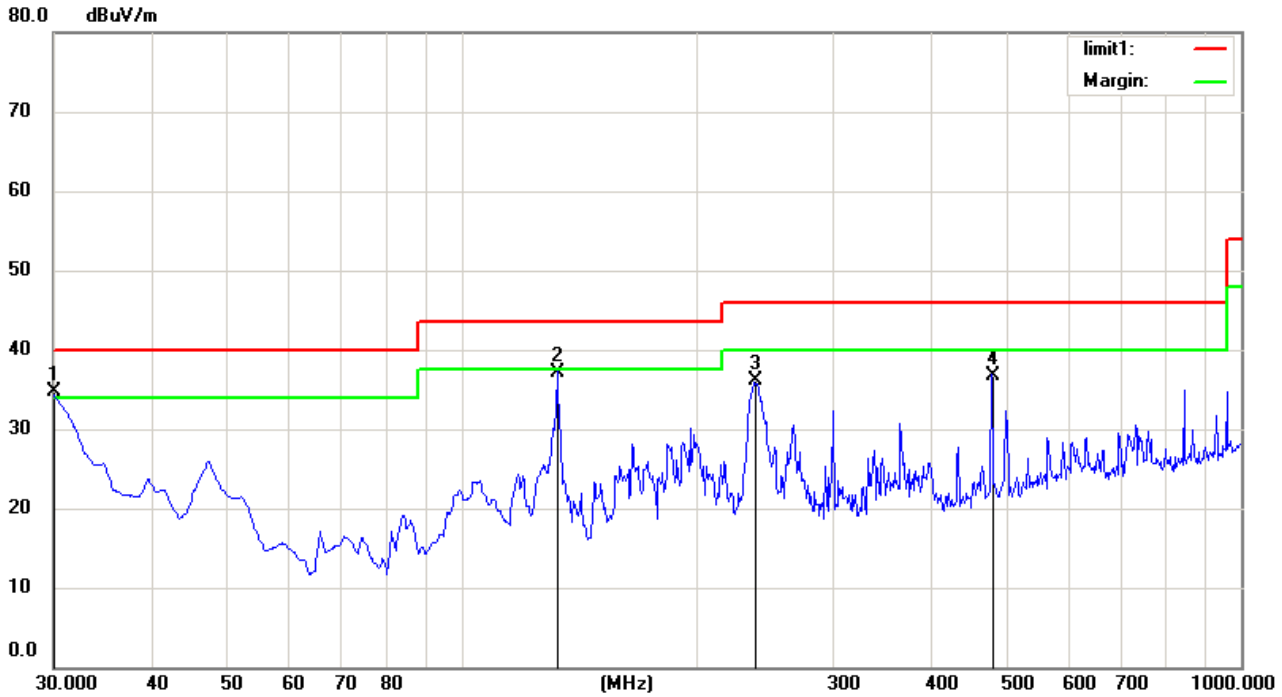

Site Chamber #1

Polarization: **Vertical**

Temperature: 26

Limit: (RE)FCC PART 15 class B 3m

Power: AC 120V/60Hz

Humidity: 55 %

EUT: 7INCH DIGITAL PHOTO FRAME

M/N: BS07N

Mode:USB PLAYING

Note: ADS-12G-0605010GPCU

No.	Mk.	Freq.	Reading Level	Correct Factor	Measurement	Limit	Over	Antenna Height	Table Degree	Comment
		MHz	dBuV	dB	dBuV/m	dBuV/m	dB	cm	degree	
1	*	30.0000	51.79	-17.15	34.64	40.00	-5.36	QP		
2		132.8200	57.65	-20.50	37.15	43.50	-6.35	QP		
3		237.5800	48.35	-12.18	36.17	46.00	-9.83	QP		
4		480.0800	44.28	-7.60	36.68	46.00	-9.32	QP		

*:Maximum data x:Over limit !:over margin

Operator:

Radiated Emission Measurement

File :BS07N(AUO)

Data :#14

Date: 09/07/10/

Time: 11/29/02

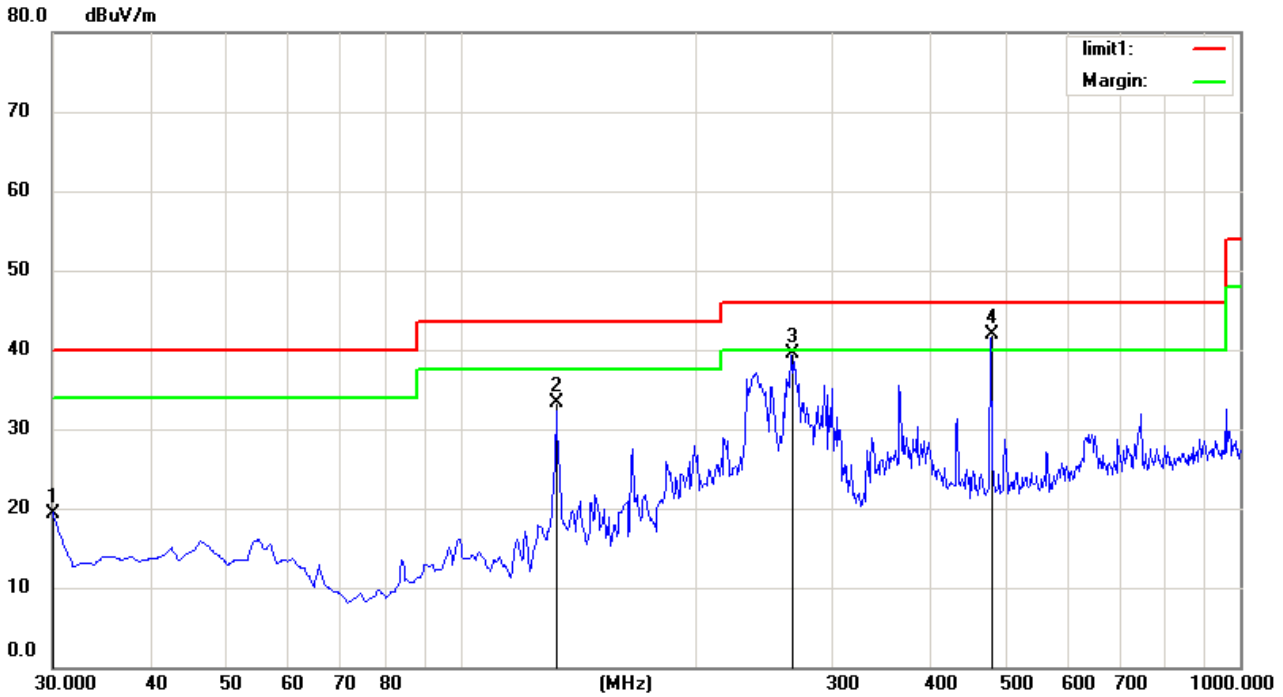

Site Chamber #1

Polarization: **Horizontal**

Temperature: 26

Limit: (RE)FCC PART 15 class B 3m

Power: AC 120V/60Hz

Humidity: 55 %

EUT: 7INCH DIGITAL PHOTO FRAME

M/N: BS07N

Mode:USB PLAYING

Note: ADS-12G-0605010GPCU

No.	Mk.	Freq.	Reading Level	Correct Factor	Measurement	Limit	Over	Antenna Height	Table Degree	
		MHz	dBuV	dB	dBuV/m	dBuV/m	dB	cm	degree	Comment
1		30.0000	36.55	-17.15	19.40	40.00	-20.60	QP		
2		132.8200	53.85	-20.50	33.35	43.50	-10.15	QP		
3		265.7100	51.25	-11.81	39.44	46.00	-6.56	QP		
4	*	480.0800	49.46	-7.60	41.86	46.00	-4.14	QP		

*:Maximum data x:Over limit !:over margin

Operator:

Radiated Emission Measurement

File :BS07N(AUO)

Data :#15

Date: 09/07/10/

Time: 11/34/08

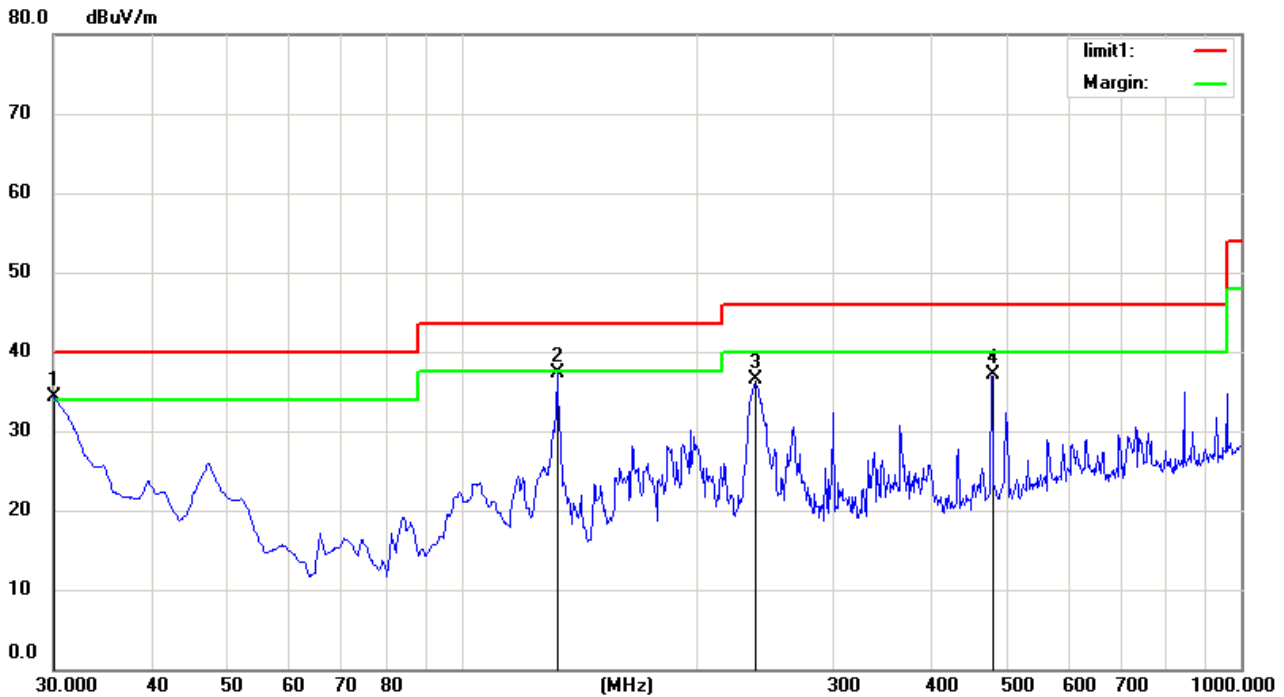

Site Chamber #1

Polarization: **Vertical**

Temperature: 26

Limit: (RE)FCC PART 15 class B 3m

Power: AC 120V/60Hz

Humidity: 55 %

EUT: 7INCH DIGITAL PHOTO FRAME

M/N: BS07N

Mode:CONNECT TO PC

Note: ADS-12G-0605010GPCU

No.	Mk.	Freq.	Reading Level	Correct Factor	Measurement	Limit	Over	Antenna Height	Table Degree	Comment
		MHz	dBuV	dB	dBuV/m	dBuV/m	dB	cm	degree	
1	*	30.0000	51.45	-17.15	34.30	40.00	-5.70	QP		
2		132.8200	57.85	-20.50	37.35	43.50	-6.15	QP		
3		237.5800	48.65	-12.18	36.47	46.00	-9.53	QP		
4		480.0800	44.75	-7.60	37.15	46.00	-8.85	QP		

*:Maximum data x:Over limit !:over margin

Operator:

Radiated Emission Measurement

File :BS07N(AUO)

Data :#16

Date: 09/07/10/

Time: 11/41/26

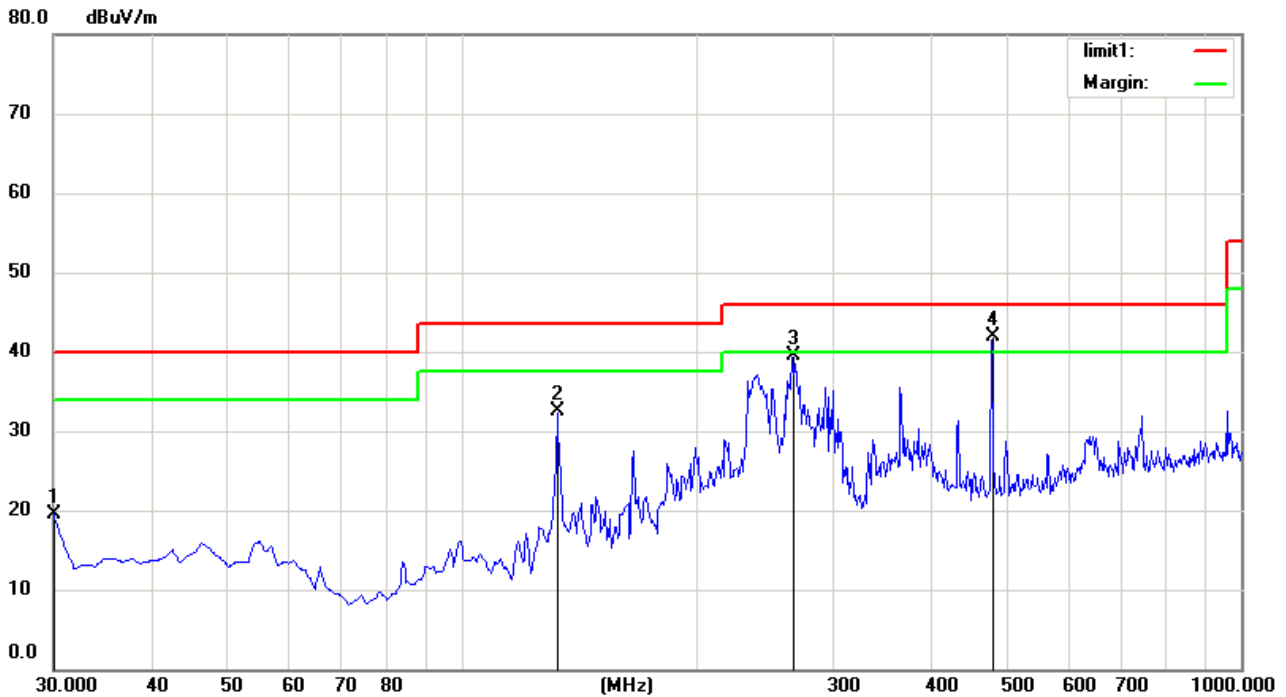

Site Chamber #1

Polarization: **Horizontal**

Temperature: 26

Limit: (RE)FCC PART 15 class B 3m

Power: AC 120V/60Hz

Humidity: 55 %

EUT: 7INCH DIGITAL PHOTO FRAME

M/N: BS07N

Mode:CONNECT TO PC

Note: ADS-12G-0605010GPCU

No.	Mk.	Freq. MHz	Reading Level dBuV	Correct Factor dB	Measure- ment dBuV/m	Limit dBuV/m	Over dB	Antenna Height cm	Table Degree degree	Comment
1		30.0000	36.75	-17.15	19.60	40.00	-20.40	QP		
2		132.8200	52.99	-20.50	32.49	43.50	-11.01	QP		
3		265.7100	51.25	-11.81	39.44	46.00	-6.56	QP		
4	*	480.0800	49.55	-7.60	41.95	46.00	-4.05	QP		

*:Maximum data x:Over limit !:over margin

Operator:

Adapter ZDA050200US used for test.

Radiated Emission Measurement

File :BS07N(AUO)

Data :#17

Date: 09/07/10/

Time: 11/45/20

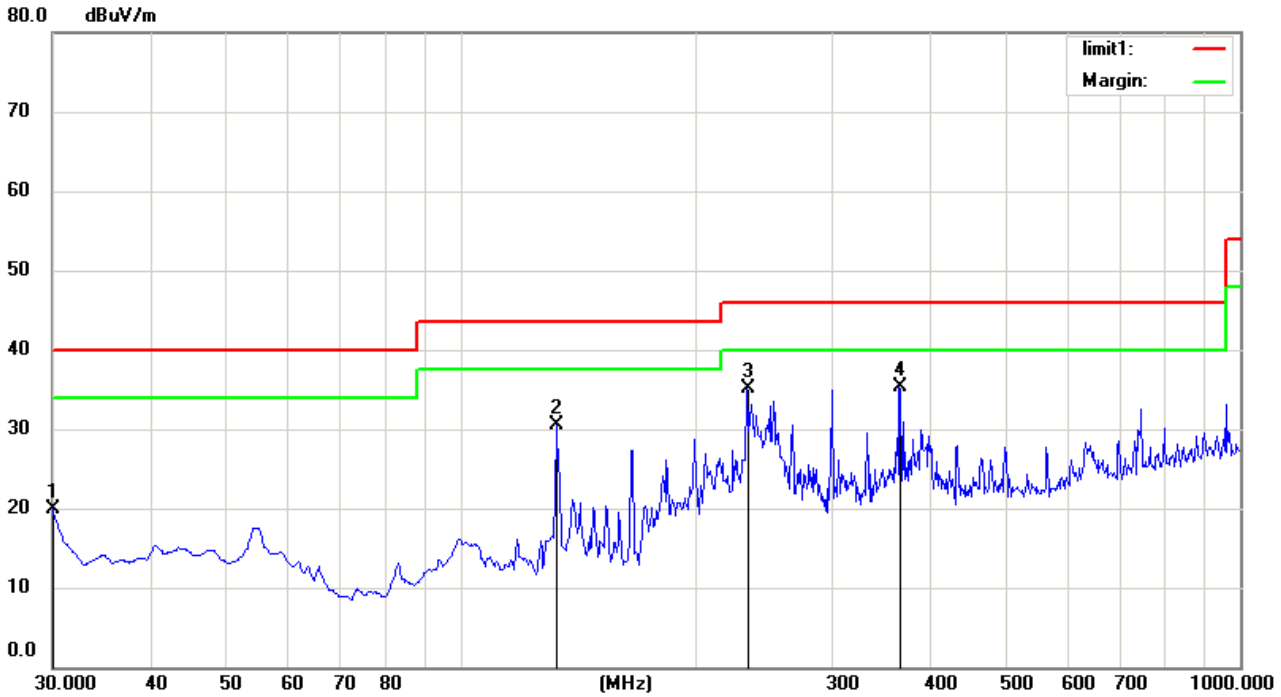

Site Chamber #1

Polarization: **Horizontal**

Temperature: 26

Limit: (RE)FCC PART 15 class B 3m

Power: AC 120V/60Hz

Humidity: 55 %

EUT: 7INCH DIGITAL PHOTO FRAME

M/N: BS07N

Mode:SD CARD PLAYING

Note: ZDA050200US

No.	Mk.	Freq. MHz	Reading Level dBuV	Correct Factor dB	Measure- ment dBuV/m	Limit dBuV/m	Over dB	Antenna Height cm	Table Degree degree	Comment
1		30.0000	37.00	-17.15	19.85	40.00	-20.15	QP		
2		132.8200	51.09	-20.50	30.59	43.50	-12.91	QP		
3		233.7000	47.51	-12.38	35.13	46.00	-10.87	QP		
4	*	366.5900	44.92	-9.56	35.36	46.00	-10.64	QP		

*:Maximum data x:Over limit !:over margin

Operator:

Radiated Emission Measurement

File :BS07N(AUO)

Data :#18

Date: 09/07/10/

Time: 11/50/16

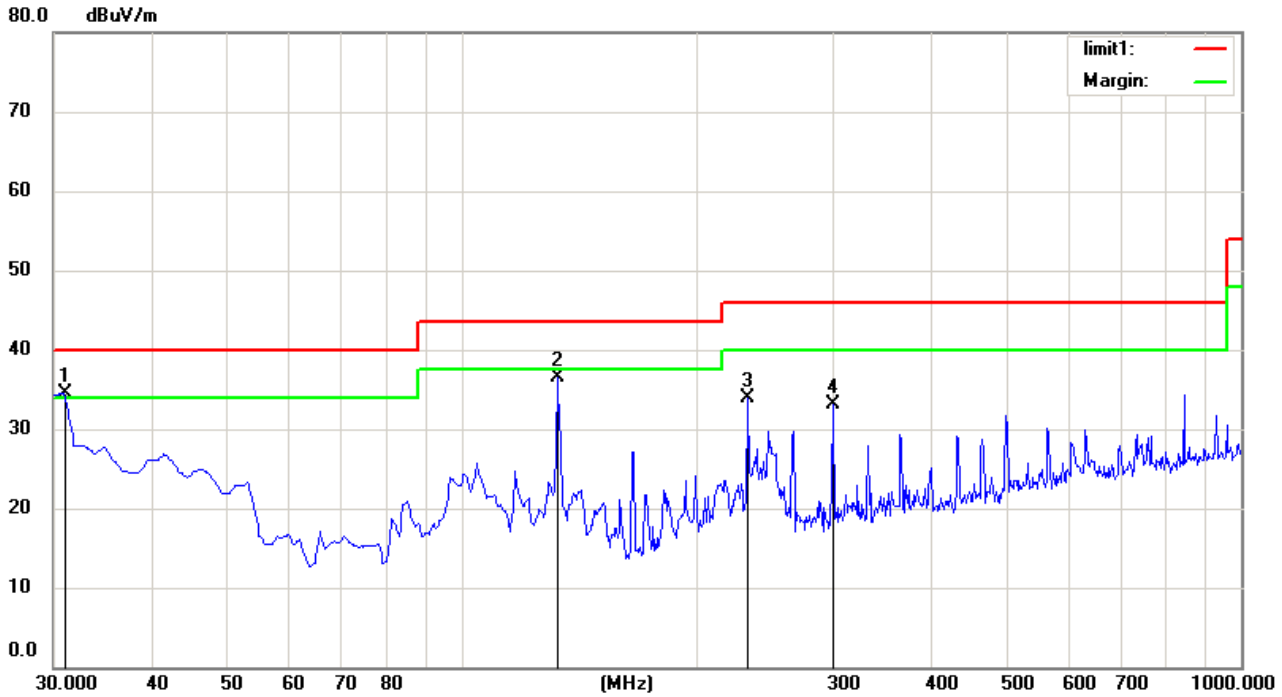

Site Chamber #1

Polarization: **Vertical**

Temperature: 26

Limit: (RE)FCC PART 15 class B 3m

Power: AC 120V/60Hz

Humidity: 55 %

EUT: 7INCH DIGITAL PHOTO FRAME

M/N: BS07N

Mode:SD CARD PLAYING

Note: ZDA050200US

No.	Mk.	Freq. MHz	Reading Level dBuV	Correct Factor dB	Measure- ment dBuV/m	Limit dBuV/m	Over dB	Antenna Height cm	Table Degree	Detector	Comment
1	*	30.9700	51.54	-17.05	34.49	40.00	-5.51			QP	
2		132.8200	56.92	-20.50	36.42	43.50	-7.08			QP	
3		232.7300	46.33	-12.43	33.90	46.00	-12.10			QP	
4		299.6600	43.79	-10.76	33.03	46.00	-12.97			QP	

*:Maximum data x:Over limit !:over margin

Operator:

Radiated Emission Measurement

File :BS07N(AUO)

Data :#19

Date: 09/07/10/

Time: 11/54/09

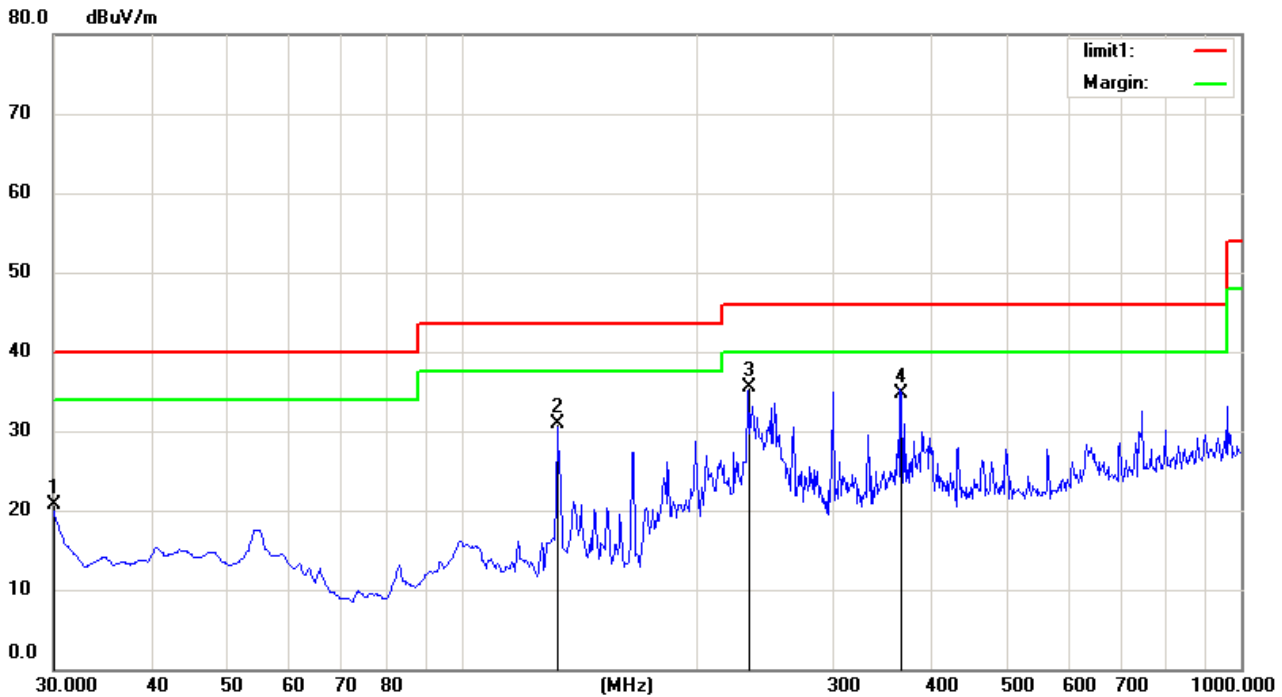

Site Chamber #1

Polarization: **Horizontal**

Temperature: 26

Limit: (RE)FCC PART 15 class B 3m

Power: AC 120V/60Hz

Humidity: 55 %

EUT: 7INCH DIGITAL PHOTO FRAME

M/N: BS07N

Mode:USB PLAYING

Note: ZDA050200US

No.	Mk.	Freq. MHz	Reading Level dBuV	Correct Factor dB	Measure- ment dBuV/m	Limit dBuV/m	Over dB	Antenna Height cm	Table Degree	Comment
1		30.0000	37.77	-17.15	20.62	40.00	-19.38	QP		
2		132.8200	51.35	-20.50	30.85	43.50	-12.65	QP		
3	*	233.7000	47.96	-12.38	35.58	46.00	-10.42	QP		
4		366.5900	44.36	-9.56	34.80	46.00	-11.20	QP		

*:Maximum data x:Over limit !:over margin

Operator:

Radiated Emission Measurement

File :BS07N(AUO)

Data :#20

Date: 09/07/10/

Time: 11/58/04

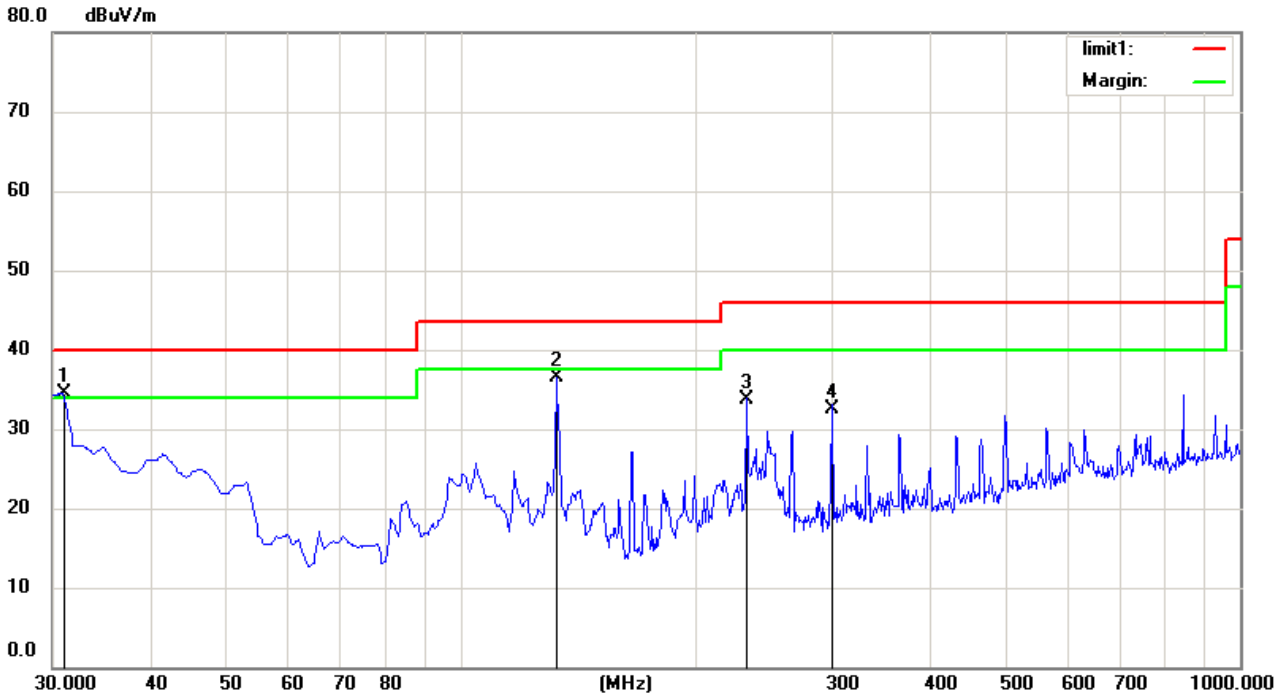

Site Chamber #1

Polarization: **Vertical**

Temperature: 26

Limit: (RE)FCC PART 15 class B 3m

Power: AC 120V/60Hz

Humidity: 55 %

EUT: 7INCH DIGITAL PHOTO FRAME

M/N: BS07N

Mode:USB PLAYING

Note: ZDA050200US

No.	Mk.	Freq.	Reading Level	Correct Factor	Measurement	Limit	Over	Antenna Height	Table Degree		
		MHz	dBuV	dB	dBuV/m	dBuV/m	dB	Detector	cm	degree	Comment
1	*	30.9700	51.64	-17.05	34.59	40.00	-5.41	QP			
2		132.8200	56.99	-20.50	36.49	43.50	-7.01	QP			
3		232.7300	46.15	-12.43	33.72	46.00	-12.28	QP			
4		299.6600	43.23	-10.76	32.47	46.00	-13.53	QP			

*:Maximum data x:Over limit !:over margin

Operator:

Radiated Emission Measurement

File :BS07N(AUO)

Data :#21

Date: 09/07/10/

Time: 12/05/07

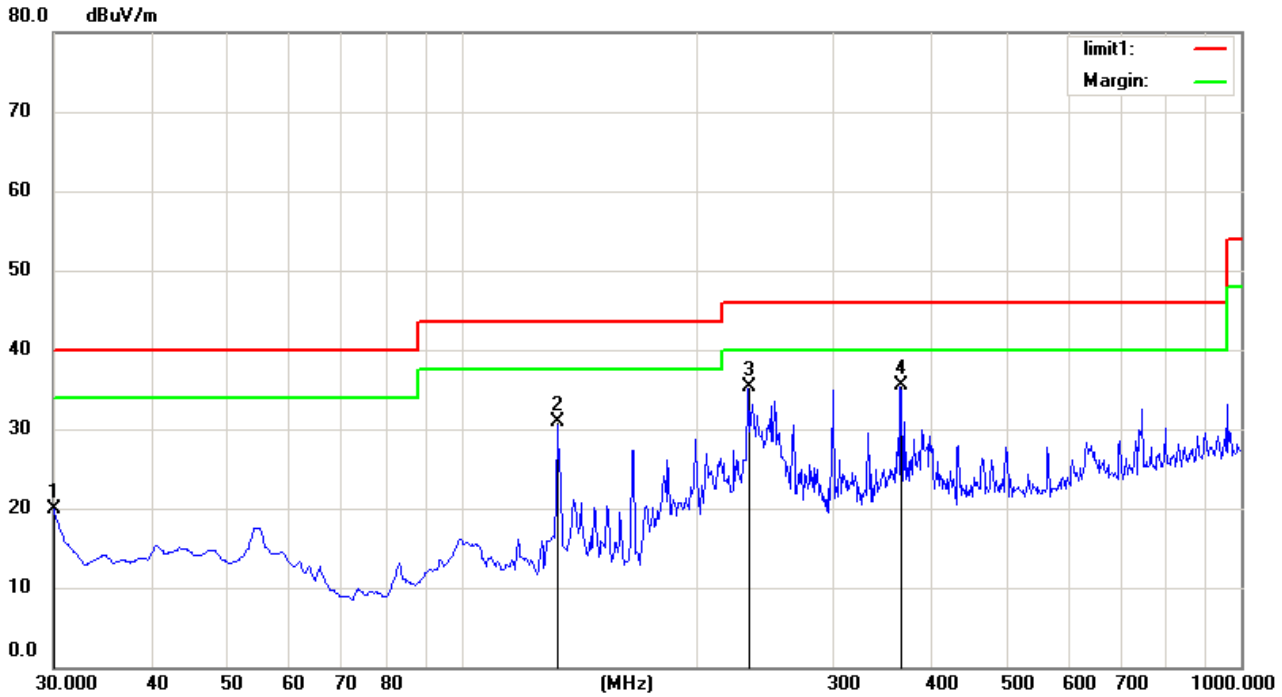

Site Chamber #1

Polarization: **Horizontal**

Temperature: 26

Limit: (RE)FCC PART 15 class B 3m

Power: AC 120V/60Hz

Humidity: 55 %

EUT: 7INCH DIGITAL PHOTO FRAME

M/N: BS07N

Mode:Memorying

Note: ZDA050200US

No.	Mk.	Freq. MHz	Reading Level dBuV	Correct Factor dB	Measure- ment dBuV/m	Limit dBuV/m	Over dB	Antenna Height cm	Table Degree degree	Comment
1		30.0000	37.07	-17.15	19.92	40.00	-20.08	QP		
2		132.8200	51.48	-20.50	30.98	43.50	-12.52	QP		
3		233.7000	47.63	-12.38	35.25	46.00	-10.75	QP		
4	*	366.5900	44.98	-9.56	35.42	46.00	-10.58	QP		

*:Maximum data x:Over limit !:over margin

Operator:

Radiated Emission Measurement

File :BS07N(AUO)

Data :#22

Date: 09/07/10/

Time: 12/11/04

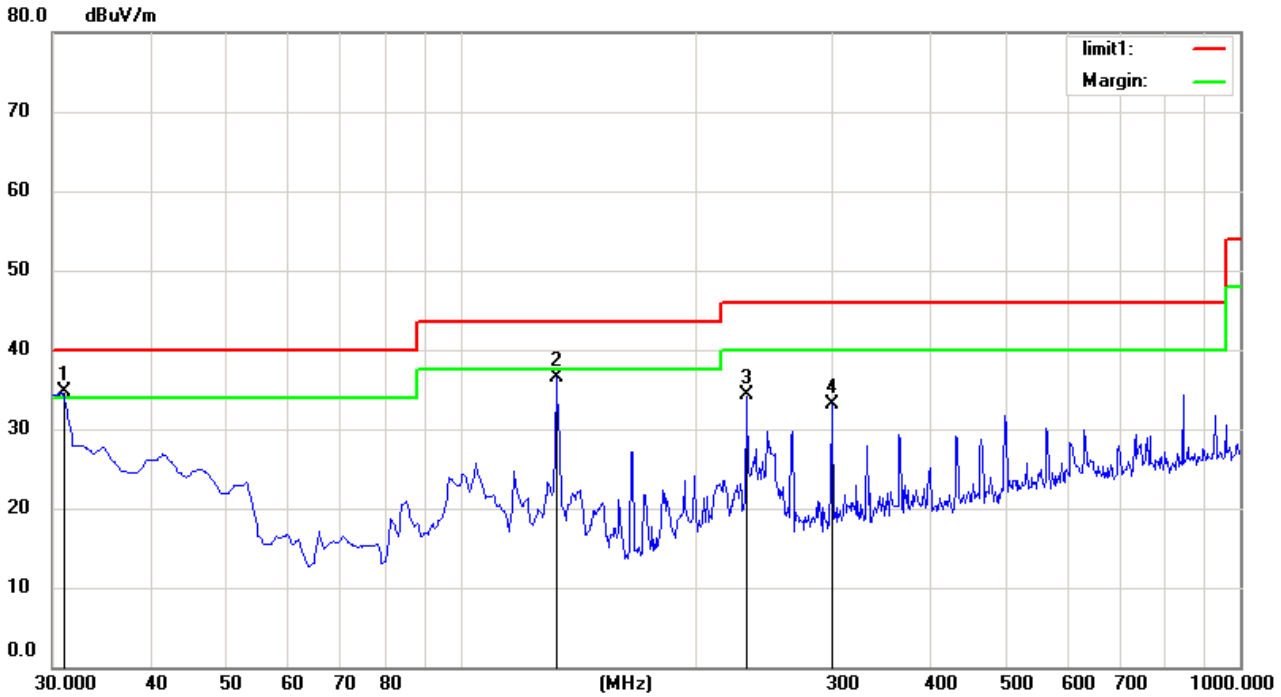

Site Chamber #1

Polarization: **Vertical**

Temperature: 26

Limit: (RE)FCC PART 15 class B 3m

Power: AC 120V/60Hz

Humidity: 55 %

EUT: 7INCH DIGITAL PHOTO FRAME

M/N: BS07N

Mode:Memorying

Note: ZDA050200US

No.	Mk.	Freq.	Reading Level	Correct Factor	Measurement	Limit	Over	Antenna Height	Table Degree		
		MHz	dBuV	dB	dBuV/m	dBuV/m	dB	Detector	cm	degree	Comment
1	*	30.9700	51.77	-17.05	34.72	40.00	-5.28	QP			
2		132.8200	56.98	-20.50	36.48	43.50	-7.02	QP			
3		232.7300	46.65	-12.43	34.22	46.00	-11.78	QP			
4		299.6600	43.89	-10.76	33.13	46.00	-12.87	QP			

*:Maximum data x:Over limit !:over margin

Operator:

Radiated Emission Measurement

File :BS07N(AUO)

Data :#23

Date: 09/07/10/

Time: 12/16/46

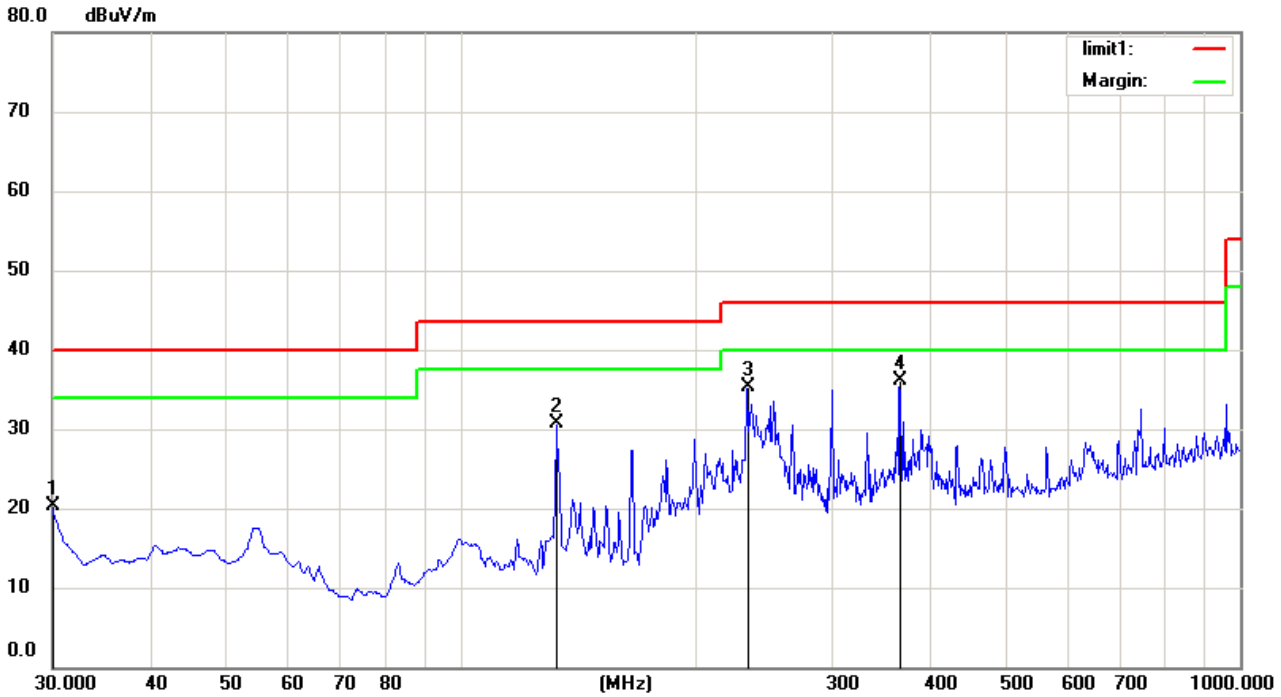

Site Chamber #1

Polarization: **Horizontal**

Temperature: 26

Limit: (RE)FCC PART 15 class B 3m

Power: AC 120V/60Hz

Humidity: 55 %

EUT: 7INCH DIGITAL PHOTO FRAME

M/N: BS07N

Mode:CONNECT TO PC

Note: ZDA050200US

No.	Mk.	Freq. MHz	Reading Level dBuV	Correct Factor dB	Measure- ment dBuV/m	Limit dBuV/m	Over dB	Antenna Height cm	Table Degree	Comment
1		30.0000	37.46	-17.15	20.31	40.00	-19.69	QP		
2		132.8200	51.12	-20.50	30.62	43.50	-12.88	QP		
3		233.7000	47.66	-12.38	35.28	46.00	-10.72	QP		
4	*	366.5900	45.63	-9.56	36.07	46.00	-9.93	QP		

*:Maximum data x:Over limit !:over margin

Operator:

Radiated Emission Measurement

File :BS07N(AUO)

Data :#24

Date: 09/07/10/

Time: 12/20/35

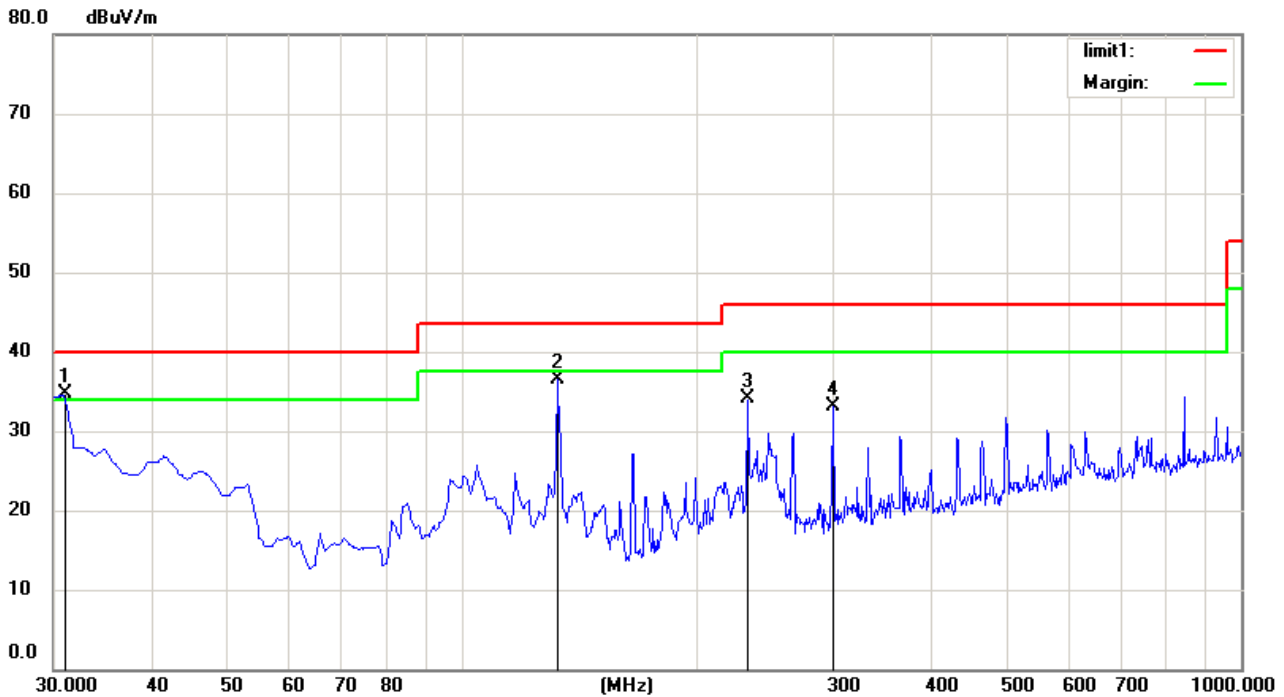

Site Chamber #1

Polarization: **Vertical**

Temperature: 26

Limit: (RE)FCC PART 15 class B 3m

Power: AC 120V/60Hz

Humidity: 55 %

EUT: 7INCH DIGITAL PHOTO FRAME

M/N: BS07N

Mode:CONNECT TO PC

Note: ZDA050200US

No.	Mk.	Freq.	Reading Level	Correct Factor	Measurement	Limit	Over	Antenna Height	Table Degree	
		MHz	dBuV	dB	dBuV/m	dBuV/m	dB	Detector	cm	degree
1	*	30.9700	51.75	-17.05	34.70	40.00	-5.30	QP		
2		132.8200	56.99	-20.50	36.49	43.50	-7.01	QP		
3		232.7300	46.44	-12.43	34.01	46.00	-11.99	QP		
4		299.6600	43.85	-10.76	33.09	46.00	-12.91	QP		

*:Maximum data x:Over limit !:over margin

Operator:

Adapter XKD-C2000IC5.0-12W used for test.

Radiated Emission Measurement

File :BS07N(AUO)

Data :#1

Date: 09/07/10/

Time: 9/59/12

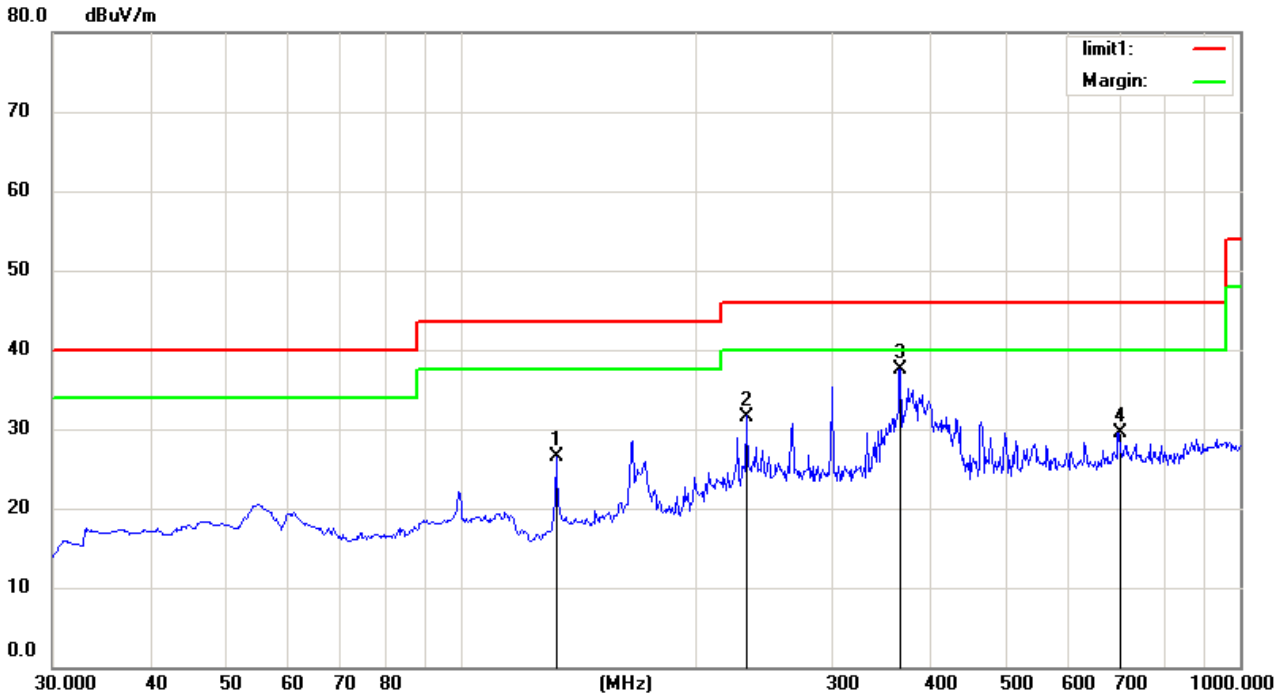

Site Chamber #1

Polarization: **Horizontal**

Temperature: 26

Limit: (RE)FCC PART 15 class B 3m

Power: AC 120V/60Hz

Humidity: 55 %

EUT: 7INCH DIGITAL PHOTO FRAME

M/N: BS07N

Mode:Memorying

Note: XKD-C2000IC5.0-12W

No.	Mk.	Freq. MHz	Reading Level dBuV	Correct Factor dB	Measure- ment dBuV/m	Limit dBuV/m	Over dB	Antenna Height cm	Table Degree	Comment
1		132.8200	47.07	-20.50	26.57	43.50	-16.93	QP		
2		232.7300	44.03	-12.43	31.60	46.00	-14.40	QP		
3	*	366.5900	47.07	-9.56	37.51	46.00	-8.49	QP		
4		701.2400	34.27	-4.71	29.56	46.00	-16.44	QP		

*:Maximum data x:Over limit !:over margin

Operator:

Radiated Emission Measurement

File :BS07N(AUO)

Data :#2

Date: 09/07/10/

Time: 10/01/17

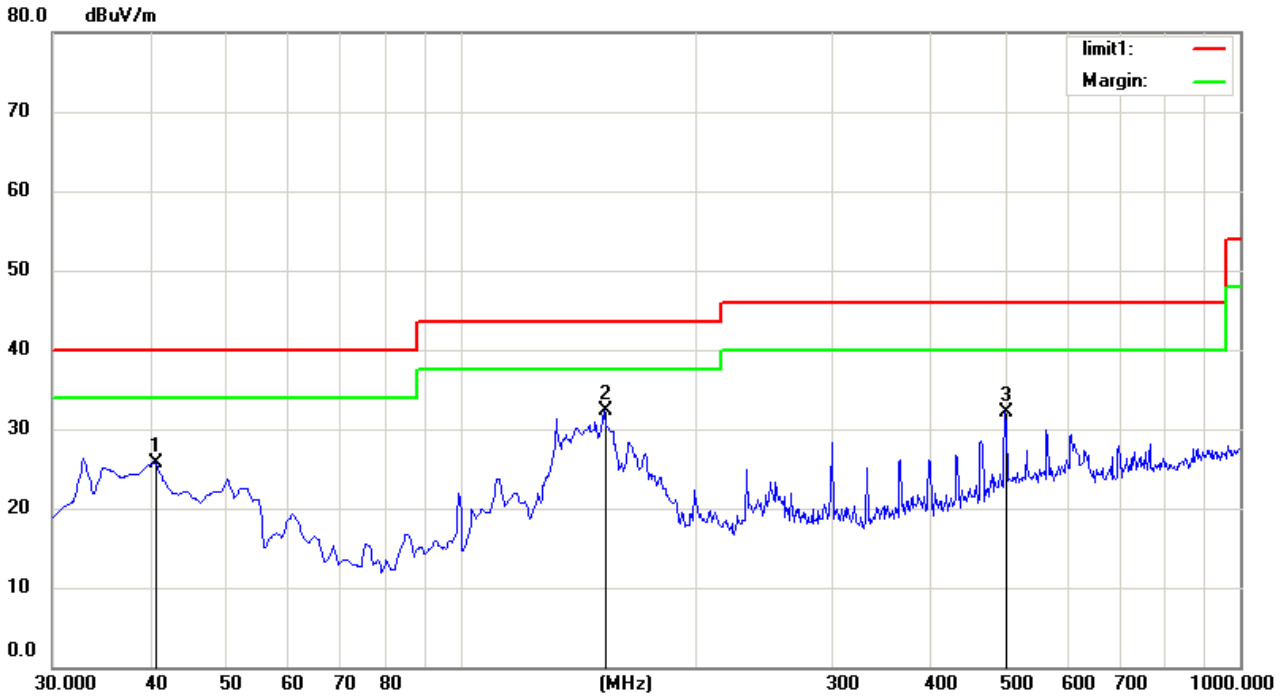

Site Chamber #1

Polarization: **Vertical**

Temperature: 26

Limit: (RE)FCC PART 15 class B 3m

Power: AC 120V/60Hz

Humidity: 55 %

EUT: 7INCH DIGITAL PHOTO FRAME

M/N: BS07N

Mode:Memorying

Note: XKD-C2000IC5.0-12W

No.	Mk.	Freq. MHz	Reading Level dBuV	Correct Factor dB	Measure- ment dBuV/m	Limit dBuV/m	Over dB	Antenna Height cm	Table Degree	Detector	Comment
1		40.6700	41.84	-16.13	25.71	40.00	-14.29			QP	
2	*	153.2004	52.60	-20.28	32.32	43.50	-11.18			QP	
3		499.4800	39.29	-7.09	32.20	46.00	-13.80			QP	

Radiated Emission Measurement

File :BS07N(AUO)

Data :#3

Date: 09/07/10/

Time: 10/26/29

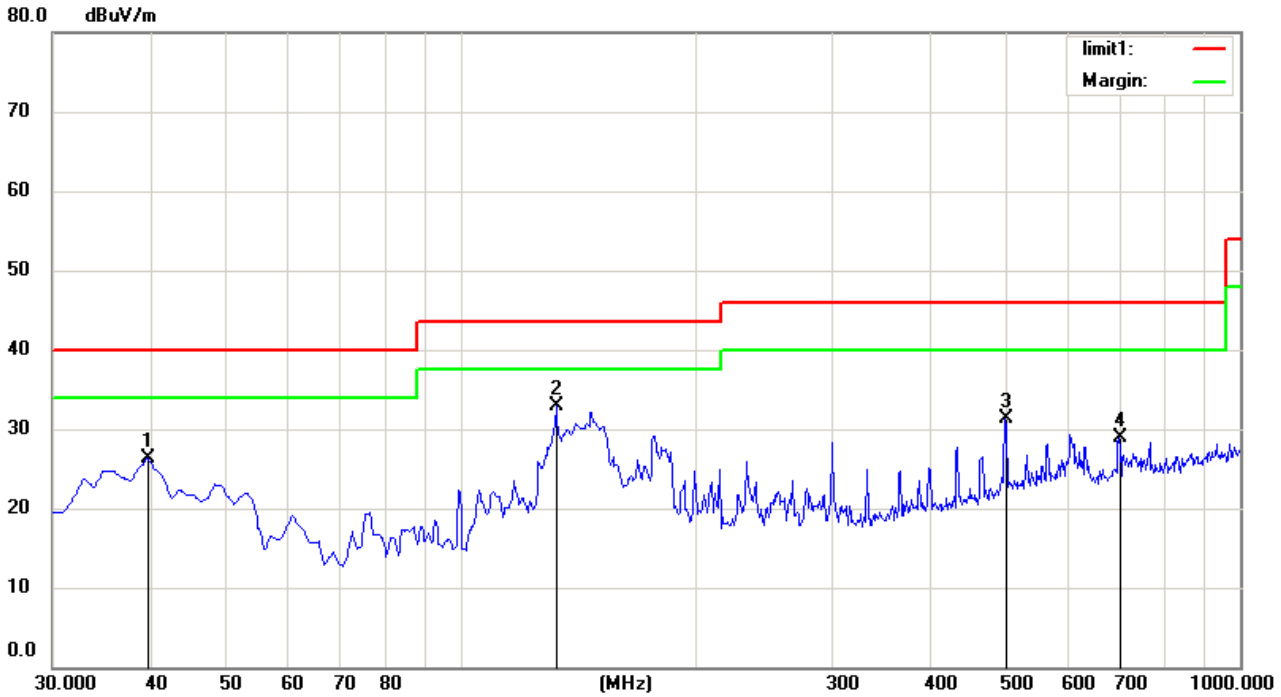

Site Chamber #1

Polarization: **Vertical**

Temperature: 26

Limit: (RE)FCC PART 15 class B 3m

Power: AC 120V/60Hz

Humidity: 55 %

EUT: 7INCH DIGITAL PHOTO FRAME

M/N: BS07N

Mode:SD CARD PLAYING

Note: XKD-C2000IC5.0-12W

No.	Mk.	Freq. MHz	Reading Level dBuV	Correct Factor dB	Measure- ment dBuV/m	Limit dBuV/m	Over dB	Antenna Height cm	Table Degree	Detector	Comment
1		39.7000	42.36	-16.15	26.21	40.00	-13.79			QP	
2	*	132.8200	53.32	-20.50	32.82	43.50	-10.68			QP	
3		500.4500	38.34	-7.08	31.26	46.00	-14.74			QP	
4		701.2400	33.56	-4.71	28.85	46.00	-17.15			QP	

*:Maximum data x:Over limit !:over margin

Operator:

Radiated Emission Measurement

File :BS07N(AUO)

Data :#4

Date: 09/07/10/

Time: 10/28/11

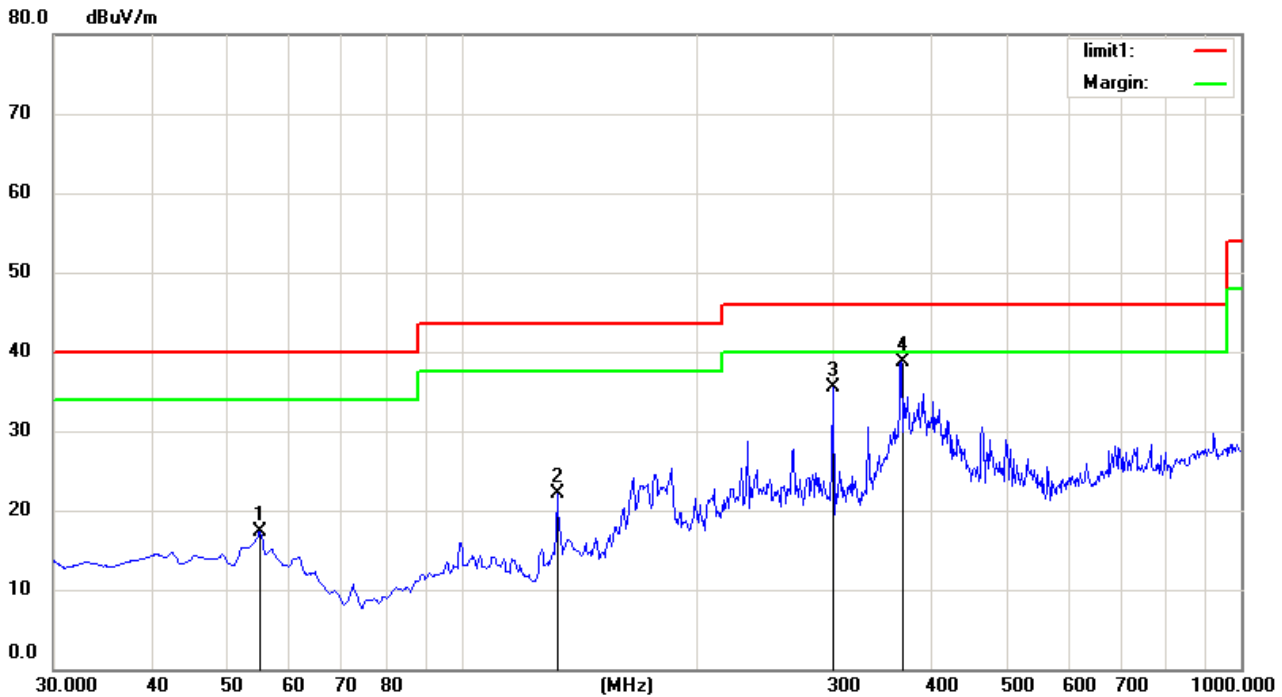

Site Chamber #1

Polarization: **Horizontal**

Temperature: 26

Limit: (RE)FCC PART 15 class B 3m

Power: AC 120V/60Hz

Humidity: 55 %

EUT: 7INCH DIGITAL PHOTO FRAME

M/N: BS07N

Mode: SD CARD PLAYING

Note: XKD-C2000IC5.0-12W

No.	Mk.	Freq. MHz	Reading Level dBuV	Correct Factor dB	Measure- ment dBuV/m	Limit dBuV/m	Over dB	Antenna Height cm	Table Degree	Comment
1		55.2200	33.99	-16.63	17.36	40.00	-22.64	QP		
2		132.8200	42.70	-20.50	22.20	43.50	-21.30	QP		
3		299.6600	46.20	-10.76	35.44	46.00	-10.56	QP		
4	*	367.5600	48.25	-9.55	38.70	46.00	-7.30	QP		

*:Maximum data x:Over limit !:over margin

Operator:

Radiated Emission Measurement

File :BS07N(AUO)

Data :#5

Date: 09/07/10/

Time: 10/34/05

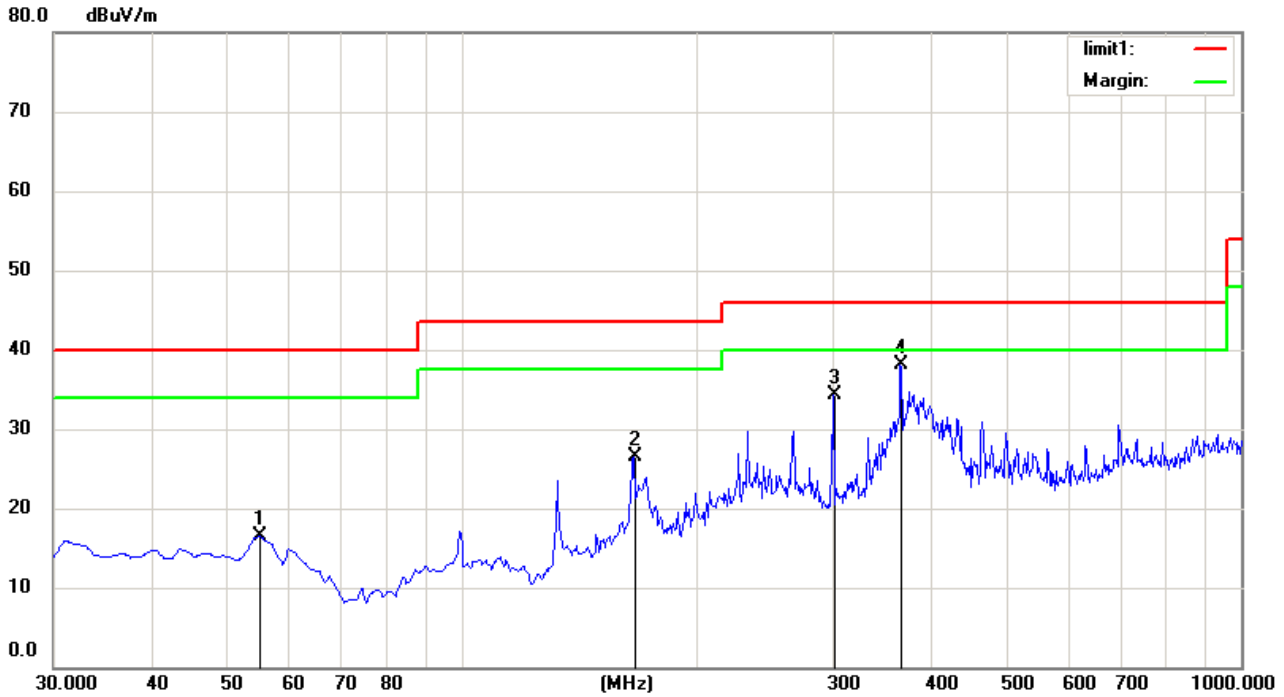

Site Chamber #1

Polarization: **Horizontal**

Temperature: 26

Limit: (RE)FCC PART 15 class B 3m

Power: AC 120V/60Hz

Humidity: 55 %

EUT: 7INCH DIGITAL PHOTO FRAME

M/N: BS07N

Mode:USB PLAYING

Note: XKD-C2000IC5.0-12W

No.	Mk.	Freq.	Reading Level	Correct Factor	Measurement	Limit	Over	Antenna Height	Table Degree	
		MHz	dBuV	dB	dBuV/m	dBuV/m	dB	Detector	cm	degree
1		55.2200	33.11	-16.63	16.48	40.00	-23.52	QP		
2		166.7700	44.99	-18.55	26.44	43.50	-17.06	QP		
3		300.6300	44.97	-10.76	34.21	46.00	-11.79	QP		
4	*	366.5900	47.57	-9.56	38.01	46.00	-7.99	QP		

*:Maximum data x:Over limit !:over margin

Operator:

Radiated Emission Measurement

File :BS07N(AUO)

Data :#6

Date: 09/07/10/

Time: 10/42/08

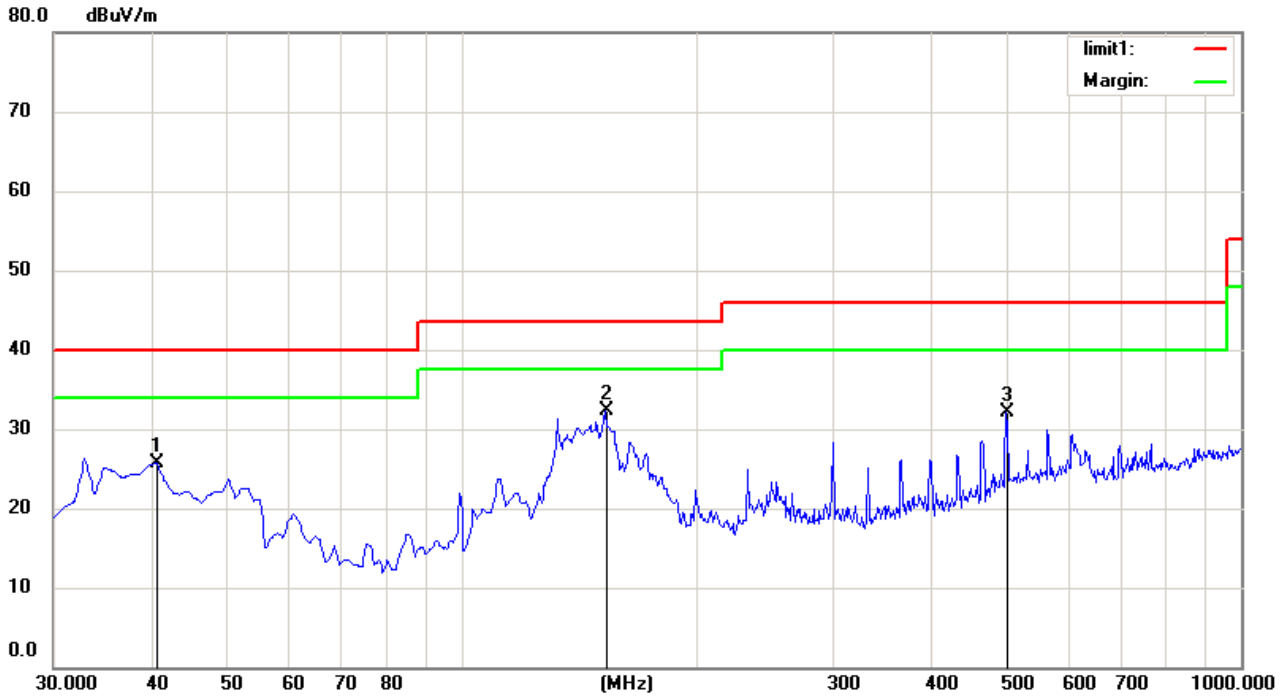

Site Chamber #1

Polarization: **Vertical**

Temperature: 26

Limit: (RE)FCC PART 15 class B 3m

Power: AC 120V/60Hz

Humidity: 55 %

EUT: 7INCH DIGITAL PHOTO FRAME

M/N: BS07N

Mode:USB PLAYING

Note: XKD-C2000IC5.0-12W

No.	Mk.	Freq.	Reading Level	Correct Factor	Measurement	Limit	Over	Antenna Height	Table Degree	Comment
		MHz	dBuV	dB	dBuV/m	dBuV/m	dB	cm	degree	
1		40.6700	41.84	-16.13	25.71	40.00	-14.29	QP		
2	*	153.2004	52.60	-20.28	32.32	43.50	-11.18	QP		
3		499.4800	39.29	-7.09	32.20	46.00	-13.80	QP		

*:Maximum data x:Over limit !:over margin

Operator:

Radiated Emission Measurement

File :BS07N(AUO)

Data :#7

Date: 09/07/10/

Time: 10/59/29

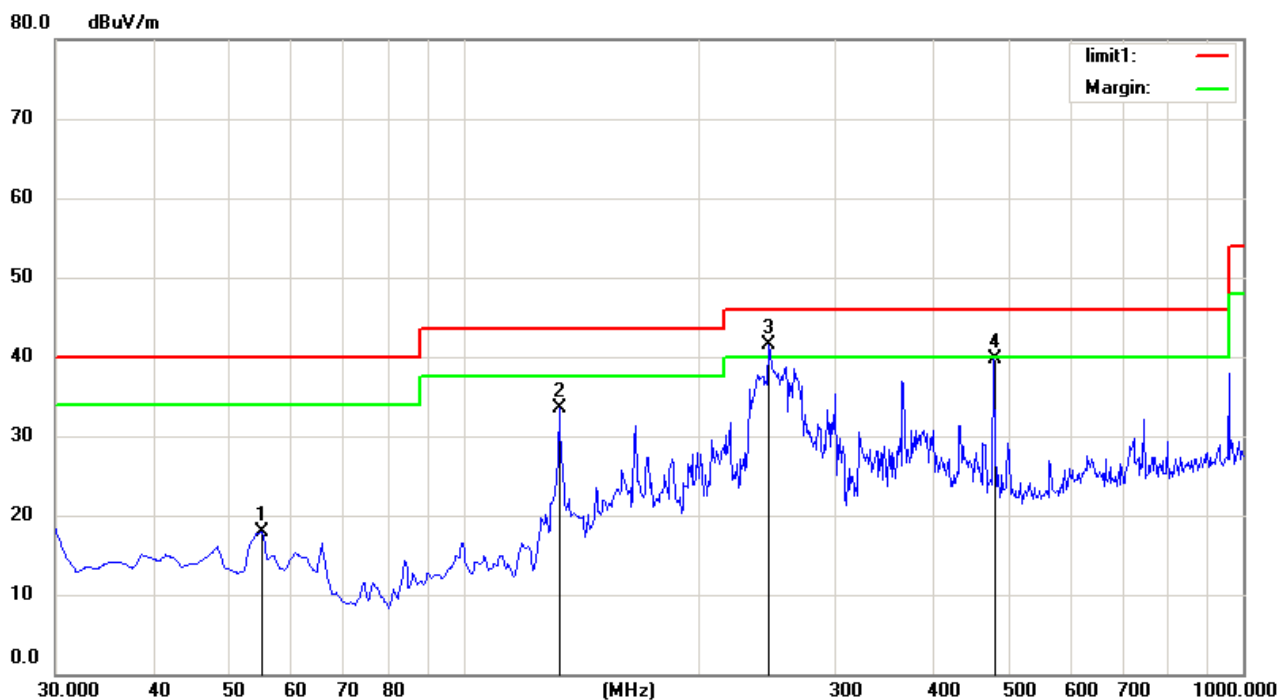

Site Chamber #1

Polarization: **Horizontal**

Temperature: 26

Limit: (RE)FCC PART 15 class B 3m

Power: AC 120V/60Hz

Humidity: 55 %

EUT: 7INCH DIGITAL PHOTO FRAME

M/N: BS07N

Mode:CONNECT TO PC

Note: XKD-C2000IC5.0-12W

No.	Mk.	Freq. MHz	Reading Level dBuV	Correct Factor dB	Measure- ment dBuV/m	Limit dBuV/m	Over dB	Antenna Height cm	Table Degree degree	Comment
1		55.2200	34.59	-16.63	17.96	40.00	-22.04	QP		
2		132.8200	54.08	-20.50	33.58	43.50	-9.92	QP		
3	*	246.3100	53.45	-11.97	41.48	46.00	-4.52	QP		
4		480.0800	47.40	-7.60	39.80	46.00	-6.20	QP		

*:Maximum data x:Over limit !:over margin

Operator:

Radiated Emission Measurement

File :BS07N(AUO)

Data :#8

Date: 09/07/10/

Time: 11/01/31

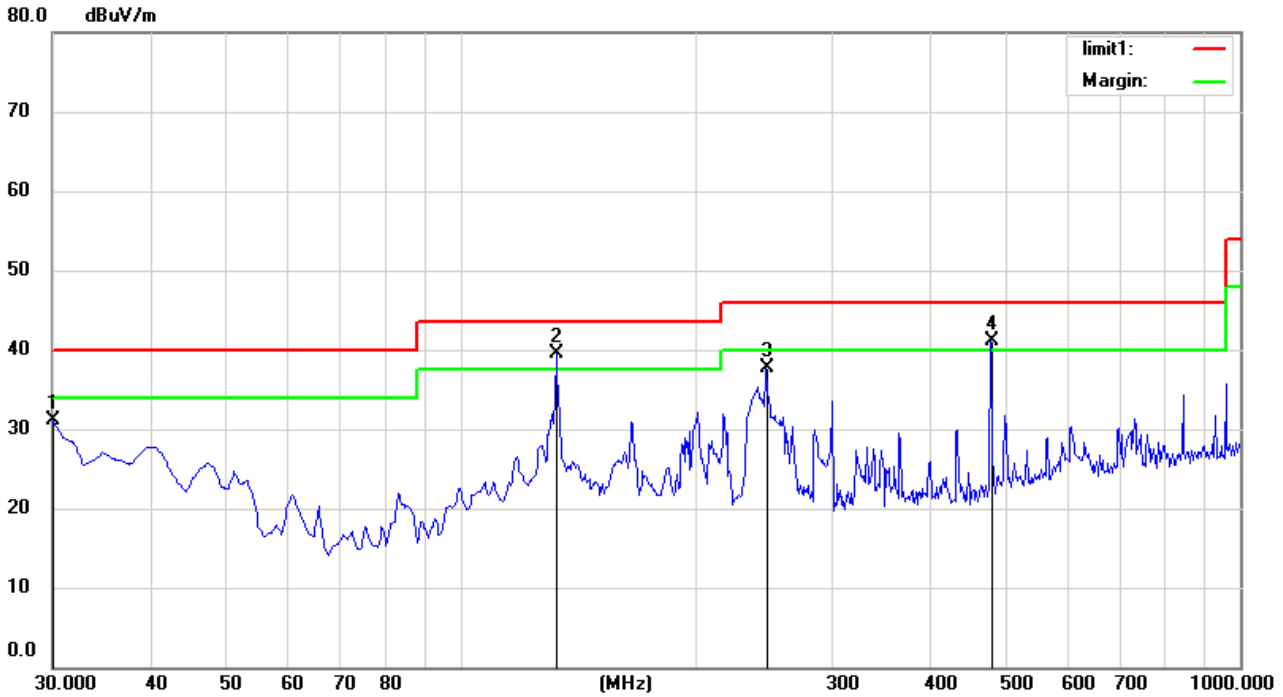

Site Chamber #1

Polarization: **Vertical**

Temperature: 26

Limit: (RE)FCC PART 15 class B 3m

Power: AC 120V/60Hz

Humidity: 55 %

EUT: 7INCH DIGITAL PHOTO FRAME

M/N: BS07N

Mode:CONNECT TO PC

Note: XKD-C2000IC5.0-12W

No.	Mk.	Freq.	Reading Level	Correct Factor	Measurement	Limit	Over	Antenna Height	Table Degree	Comment
		MHz	dBuV	dB	dBuV/m	dBuV/m	dB	cm	degree	
1		30.0000	48.23	-17.15	31.08	40.00	-8.92	QP		
2	*	132.8200	59.96	-20.50	39.46	43.50	-4.04	QP		
3		247.2800	49.58	-11.96	37.62	46.00	-8.38	QP		
4	!	480.0800	48.61	-7.60	41.01	46.00	-4.99	QP		

*:Maximum data x:Over limit !:over margin

Operator: